

IntelliStation Z Pro
Types 6223 and 6227



Hardware Maintenance Manual and Troubleshooting Guide

IntelliStation Z Pro
Types 6223 and 6227



Hardware Maintenance Manual and Troubleshooting Guide

Notes

- Before using this information and the product it supports, read the general information in Appendix B, "Safety information," on page 127, and Appendix C, "Notices," on page 161.
- **The most recent version of this document is available at <http://www.ibm.com/pc/support>.**

12th (July 2010)

© Copyright IBM Corporation 2004, 2009.

US Government Users Restricted Rights – Use, duplication or disclosure restricted by GSA ADP Schedule Contract with IBM Corp.

About this document

This document contains basic configuration information, diagnostic information, error codes, error messages, service information, and a symptom-to-FRU index for the IBM® IntelliStation® Z Pro Types 6223 and 6227 computers.

Important: The field replaceable unit (FRU) procedures in this document are intended for trained servicers who are familiar with IBM products. Customer replacement units (CRUs) can be replaced by the customer. See Chapter 7, “Parts listing Types 6223 and 6227,” on page 115, to determine if the component being replaced is a FRU or a CRU. Before servicing an IBM product, be sure to read Appendix B, “Safety information,” on page 127.

Important safety information

Be sure to read all caution and danger statements in this book before performing any of the instructions.

Leia todas as instruções de cuidado e perigo antes de executar qualquer operação.

在安装本产品之前，请仔细阅读 **Safety Information** (安全信息)。

安裝本產品之前，請先閱讀「安全資訊」。

Prenez connaissance de toutes les consignes de type Attention et

Danger avant de procéder aux opérations décrites par les instructions.

Lesen Sie alle Sicherheitshinweise, bevor Sie eine Anweisung ausführen.

Accertarsi di leggere tutti gli avvisi di attenzione e di pericolo prima di effettuare qualsiasi operazione.

製品の設置の前に、安全情報をお読みください。

본 제품을 설치하기 전에 안전 정보를 읽으십시오.

Lea atentamente todas las declaraciones de precaución y peligro ante de llevar a cabo cualquier operación.

WARNING: Handling the cord on this product or cords associated with accessories sold with this product, will expose you to lead, a chemical known to the State of California to cause cancer, and birth defects or other reproductive harm. ***Wash hands after handling.***

ADVERTENCIA: El contacto con el cable de este producto o con cables de accesorios que se venden junto con este producto, pueden exponerle al plomo, un elemento químico que en el estado de California de los Estados Unidos está considerado como un causante de cancer y de defectos congénitos, además de otros riesgos reproductivos. ***Lávese las manos después de usar el producto.***

Online support

You can download the most current diagnostic, BIOS flash, and device-driver files from <http://www.ibm.com/support>.

Contents

About this document	iii
Important safety information	iii
Online support	iv
Chapter 1. Introduction	1
Related documentation	1
Notices and statements used in this document.	2
Features and specifications.	3
What your computer offers	4
Reliability, availability, and serviceability features	4
Controls, LEDs, and connectors	6
Turning on the computer.	8
Turning off the computer.	9
Chapter 2. Configuring the computer	11
Starting the Configuration/Setup Utility program	12
Chapter 3. Diagnostics	13
General checkout	13
Diagnostic tools overview	14
Power-on self-test (POST).	15
POST beep codes	15
POST error messages	16
Diagnostic programs and error messages	16
Text messages	16
Starting the diagnostic programs and viewing the test log	17
Small computer system interface (SCSI) messages	17
PC-Doctor for Windows.	18
Updating (flash-updating) the BIOS code on the computer	18
Recovering from a POST/BIOS update failure	19
Erasing a lost or forgotten password (clearing CMOS)	20
Replacing the battery	21
Power checkout	22
Chapter 4. Installing options	23
Installation guidelines	23
System reliability considerations	23
Handling static-sensitive devices	23
Installing options in your computer.	24
Major components of your computer	24
Removing the side cover	25
Removing the bezel	26
Installing an adapter	26
Cabling an optional SCSI adapter	30
Installing a drive	31
Installing memory modules	41
Installing a second microprocessor	44
Installing an external SCSI cable	48
Installing a security rope clip	49
Replacing the bezel	50
Replacing the side cover	51
Connecting external options	52
Input/output connectors.	53

Audio connectors	54
Auxiliary-device (pointing-device) connector	54
Ethernet (RJ-45) connector	54
IEEE 1394A (FireWire) connector	55
Keyboard connector	55
Parallel connector	55
Serial connectors	56
Ultra320 SCSI connector	56
Universal Serial Bus connectors	57
Video connector	57
Chapter 5. Field replaceable units	59
Microprocessor and heat sink	60
CD-ROM drive	61
Non-hot swap power supply	62
Rear-adaptor retention bracket	63
I/O card retainer	64
Front (microprocessor) fan	65
Hard drive fan	66
Power/LED switch assembly	68
Card/bracket assembly	69
Speaker	70
System board	71
System board option connectors	71
System board internal connectors	72
System board external connectors	73
System board error LEDs	74
System board jumpers and switches	75
Removing the system board	76
Top/side cover	78
Bezel-release latch	79
Handle assembly	81
Chapter 6. Symptom-to-FRU index	83
Beep symptoms	83
No-beep symptoms	85
POST error codes	85
Diagnostic error codes	90
Diagnostic error LEDs	95
Error symptoms	95
Hot-swap power-supply LED errors	103
Service processor error codes	104
SCSI error codes	104
ServeRAID error codes	105
POST (ISPR) error procedures	107
Temperature error messages	109
Fan error messages	109
Power error messages	110
System shutdown	110
Voltage-related system shutdown	110
Temperature-related system shutdown	111
Hard disk drive checkout	111
Host built-in self test (BIST)	112
Bus fault messages	112
Undetermined problems	113
Problem determination tips	114

Chapter 7. Parts listing Types 6223 and 6227	115
System	116
System replaceable units.	117
Recovery CD (Windows XP)	121
Keyboards (CRUs)	121
Power cords (CRUs)	122
Appendix A. Getting help and technical assistance	125
Before you call	125
Using the documentation.	125
Getting help and information from the World Wide Web	126
Software service and support	126
Hardware service and support.	126
Appendix B. Safety information	127
General safety	127
Electrical safety	128
Safety inspection guide	129
Handling electrostatic discharge-sensitive devices	130
Grounding requirements	130
Safety notices (multilingual translations)	131
Appendix C. Notices	161
Edition notice	161
Trademarks.	162
Important notes	163
Product recycling and disposal	163
Battery return program	164
Electronic emission notices	164
Federal Communications Commission (FCC) statement	164
Industry Canada Class B emission compliance statement.	165
Avis de conformité à la réglementation d'Industrie Canada	165
European Union EMC Directive conformance statement	165
Japanese Voluntary Control Council for Interference (VCCI) statement	165
Index	167

Chapter 1. Introduction

The IBM IntelliStation Z Pro Types 6223 and 6227 incorporates many of the latest advances in computing technology and can be expanded and upgraded as your needs change.

You can obtain up-to-date information about your computer and other IBM computer products at <http://www.ibm.com/pc/intellistation/>.

Note: The illustrations in this document might differ slightly from your hardware.

Related documentation

This *Hardware Maintenance Manual and Troubleshooting Guide* is provided in Portable Document Format (PDF). It contains information to help a user solve problems or to provide helpful information to a service technician. The following documents also come with the computer:

- *Installation Guide*

This printed document contains setup and installation instructions.

- *User's Guide*

This document is in Portable Document Format (PDF) on the IBM *IntelliStation Documentation* CD. It contains detailed information about your computer and how to use and configure the functions of the computer.

- *Safety Information*

This document is in Portable Document Format (PDF) on the IBM *IntelliStation Documentation* CD. It contains translated caution and danger statements. Each caution and danger statement that appears in the documentation has a number that you can use to locate the corresponding statement in your language in the *Safety Information* document.

- *Adaptec SCSI documentation*

This document is in PDF on the *Device Drivers* CD. It contains information and instructions for installing and configuring small computer system interface (SCSI) device drivers and devices.

- Readme files on the *Device Drivers* CD

Several readme files on this CD contain information about the preinstalled device drivers. Other readme files on this CD contain information about the various adapters and devices that might be installed in or attached to your computer.

- IBM *IntelliStation Documentation* CD

This CD contains all of the IBM IntelliStation Z Pro Type 6223 documents in Portable Document Format (PDF).

Depending on your computer model, additional documentation might be included on the IBM *IntelliStation Documentation* CD.

Your computer might have features that are not described in the documentation that you received with the computer. The documentation might be updated occasionally to include information about those features, or technical updates might be available to provide additional information that is not included in your computer documentation. These updates are available from the IBM Web site. Complete the following steps to check for updated documentation and technical updates:

1. Go to <http://www.ibm.com/pc/support/>.
2. In the **Learn** section, click **Publications**.
3. On the “Publications” page, in the **Brand** field, select **IntelliStation**.
4. In the **Family** field, select **IntelliStation Z Pro**.
5. Click **Continue**.

Notices and statements used in this document

The caution and danger statements that appear in this document are also in the multilingual *Safety Information* document, which is on the IBM *IntelliStation Documentation* CD. Each statement is numbered for reference to the corresponding statement in the *Safety Information* document.

The following notices and statements are used in this document:

- **Notes:** These notices provide important tips, guidance, or advice.
- **Important:** These notices provide information or advice that might help you avoid inconvenient or problem situations.
- **Attention:** These notices indicate potential damage to programs, devices, or data. An attention notice is placed just before the instruction or situation in which damage could occur.
- **Caution:** These statements indicate situations that can be potentially hazardous to you. A caution statement is placed just before the description of a potentially hazardous procedure step or situation.
- **Danger:** These statements indicate situations that can be potentially lethal or extremely hazardous to you. A danger statement is placed just before the description of a potentially lethal or extremely hazardous procedure step or situation.

Features and specifications

The following table provides a summary of the features and specifications of your computer. Depending on your model, some features might not be available, or some specifications might not apply.

Table 1. Features and specifications

<p>Microprocessor:</p> <ul style="list-style-type: none"> • Supports up to two Intel® Xeon microprocessors • 1 MB Level-2 cache • 800 MHz front-side bus (FSB) <p>Memory:</p> <ul style="list-style-type: none"> • Minimum: 512 MB • Maximum: 8 GB (depending on your configuration) • Type: PC2-3200 double-data-rate 2 (DDR2) registered • Connectors: six dual inline memory module (DIMM) connectors <p>Internal Drives:</p> <ul style="list-style-type: none"> • Hard disk drive: SCSI or Serial ATA (SATA) • One of the following optical drives: <ul style="list-style-type: none"> – CD-ROM: IDE – DVD/CD-RW combo: IDE – CD-RW: IDE <p>Expansion bays:</p> <ul style="list-style-type: none"> • Three slim-high 3.5-inch drive bays (one hard disk drive installed in some models) • Two half-high 5.25-inch bays (optical drive installed in one bay) • One slim-high 3.5-inch removable-media or hard disk drive bay <p>PCI expansion slots:</p> <ul style="list-style-type: none"> • Two 33 MHz/32-bit PCI, 5.0 V signaling • Two 100 MHz/64-bit PCI-X slots, 3.3 V signaling • One 133 MHz/64-bit PCI-X slot, 3.3 V signaling • One PCI Express x16 slot <p>Power supply:</p> <p>One 530 watts (115-230 V ac)</p> <p>Cooling:</p> <p>Four speed-controlled fans</p>	<p>Integrated functions:</p> <ul style="list-style-type: none"> • Broadcom 5721 10/100/1000 Ethernet controller with RJ-45 Ethernet connector • Integrated RAID capability • Integrated SCSI controller with two Ultra320 SCSI ports (one internal, one optional external) • Two serial ports • One parallel port • Dual port Serial ATA controller • Two IEEE 1394A (FireWire) ports (four-pin on front, six-pin on rear) • Six Universal Serial Bus (USB) ports (two on front and four on rear) • Keyboard port • Mouse port • Audio ports <ul style="list-style-type: none"> – Line out (front and rear) – Mic (front and rear) – Line in (rear only) • ATA-100 single-channel IDE controller <p>Video adapter: (depending on your model)</p> <ul style="list-style-type: none"> • NVIDIA Quadro NVS 280 (DMS-59), PCI Express x16, with 64 MB DDR synchronous dynamic random access memory (SDRAM) video memory and dual analog connectors (or dual digital monitor capability with the purchase of an additional pigtail cable) • NVIDIA Quadro FX 1300 (DVI-I), PCI Express x16, with 128 MB DDR SDRAM video memory with dual DVI-I connectors • NVIDIA Quadro FX 3400 (DVI-I), PCI Express x16, with 256 MB GDDR3 SDRAM video memory with dual DVI-I connectors <p>Electrical input:</p> <ul style="list-style-type: none"> • Sine-wave input (50 or 60 Hz) required • Input voltage and frequency ranges automatically selected • Input voltage low range: <ul style="list-style-type: none"> – Minimum: 90 V ac – Maximum: 137 V ac • Input voltage high range: <ul style="list-style-type: none"> – Minimum: 180 V ac – Maximum: 265 V ac • Input kilovolt-amperes (kVA) approximately: <ul style="list-style-type: none"> – Minimum: 0.24 kVA – Maximum: 0.86 kVA 	<p>Heat output:</p> <p>Approximate heat output in British thermal units (Btu) per hour:</p> <ul style="list-style-type: none"> • Minimum configuration: 787 Btu (230 watts) • Maximum configuration: 2780 Btu (815 watts) <p>Environment:</p> <ul style="list-style-type: none"> • Air temperature: <ul style="list-style-type: none"> – Computer on: 10° to 35°C (50° to 95°F). Altitude: 0 to 2134 m (7000 ft) – Computer off: -40° to +60°C (-40° to 140°F). Maximum altitude: 2133 m (7000 ft) • Humidity (operating and storage): 8% to 80% <p>Acoustical noise emissions:</p> <ul style="list-style-type: none"> • Sound power, idle: 5.0 bel • Sound power, operating: 5.3 bel <p>Size:</p> <ul style="list-style-type: none"> • Height: 469.9 mm (18.5 in.) • Depth: 495.3 mm (19.5 in.) • Width: 215.9 mm (8.5 in.) • Weight: 16.2 kg (36 lb) to 22.6 kg (50 lb) depending upon configuration <p>Notes:</p> <ol style="list-style-type: none"> 1. Power consumption and heat output vary depending on the number and type of optional features installed and the power-management optional features in use. 2. These levels were measured in controlled acoustical environments according to the procedures specified by the American National Standards Institute (ANSI) S12.10 and ISO 7779 and are reported in accordance with ISO 9296. Actual sound-pressure levels in a given location might exceed the average values stated because of room reflections and other nearby noise sources. The declared sound-power levels indicate an upper limit, below which a large number of computers will operate.
---	--	---

What your computer offers

Your computer uses the following features and technologies:

- **Multiple microprocessor capability**

Your computer can be upgraded to a symmetric multiprocessing (SMP) computer through a microprocessor upgrade.

- **PCI Express, x16, graphics**

Your computer comes with a graphics adapter installed in the PCI Express x16 slot (slot 1). This high-performance adapter supports high resolutions and includes many performance-enhancing features for your operating-system environment.

- **Large system-memory capacity**

Your computer supports up to 8 GB (when using 2 GB double-rank DIMMs) of system memory. The memory controller provides error correcting code (ECC) support for up to four industry-standard PC2-3200, 1.8 V, 240-pin, 400 megahertz (MHz) (bus speed) registered, double-data-rate (DDR), synchronous dynamic random access memory (SDRAM) dual inline memory modules (DIMMs).

Note: The Microsoft Windows XP operating systems recognize and support a maximum of 4 GB of system memory.

- **Systems-management capabilities**

Your computer comes with features that a network administrator or server can use to remotely manage and control the computer. These features include Wake on LAN, Remote Administration, and IBM Director Agent.

The memory controller in your computer provides Chipkill memory protection if the DIMMs are 1 GB or larger. Chipkill memory protection is a technology that protects the computer from a single chip failure on a DIMM.

- **Integrated network support**

Your computer comes with an integrated Ethernet controller, which supports connection to a 10-Mbps, 100-Mbps, or 1-Gbps network. The controller supports Wake on LAN technology.

Reliability, availability, and serviceability features

Three important computer design features are reliability, availability, and serviceability (RAS). The RAS features help to ensure the integrity of the data that is stored in your computer, the availability of the computer when you need it, and the ease with which you can diagnose and repair problems.

Your computer has the following RAS features:

- 24 hours a day, 7 days a week¹ customer support
- 3-year limited warranty
- Advanced Configuration and Power Interface (ACPI)
- Auto-restart initial program load (IPL) power supply
- Automatic computer restart after a power failure
- Automatic error retry or recovery
- Boot-block recovery
- Built-in, menu-driven configuration and setup programs

1. Service availability will vary by country. Response time varies; may exclude holidays.

- Built-in, menu-driven SCSI configuration programs (some models)
- Diagnostic programs
- Cooling fans with speed-sensing capability
- Error codes and messages
- Error correcting code (ECC) double-data-rate (DDR) synchronous dynamic random access memory (SDRAM) with serial presence detect (SPD)
- Hard disk drive partition-based diagnostic programs
- Integrated Ethernet controller
- Monitoring support for temperatures, voltages, and fan speed
- Power-on self-test (POST)
- Self-Monitoring Analysis and Reporting Technology (SMART) on hard disk drives for early prediction of failures
- Read-only memory (ROM) checksums
- Upgradeable basic input/output system (BIOS) and POST code
- Wake on LAN capability

Controls, LEDs, and connectors

The following illustration shows the controls, LEDs, and front connectors on the IntelliStation Z Pro Types 6223 and 6227 computers. See “Input/output connectors” on page 53 for an illustration and description of the connectors on the rear of the computer.

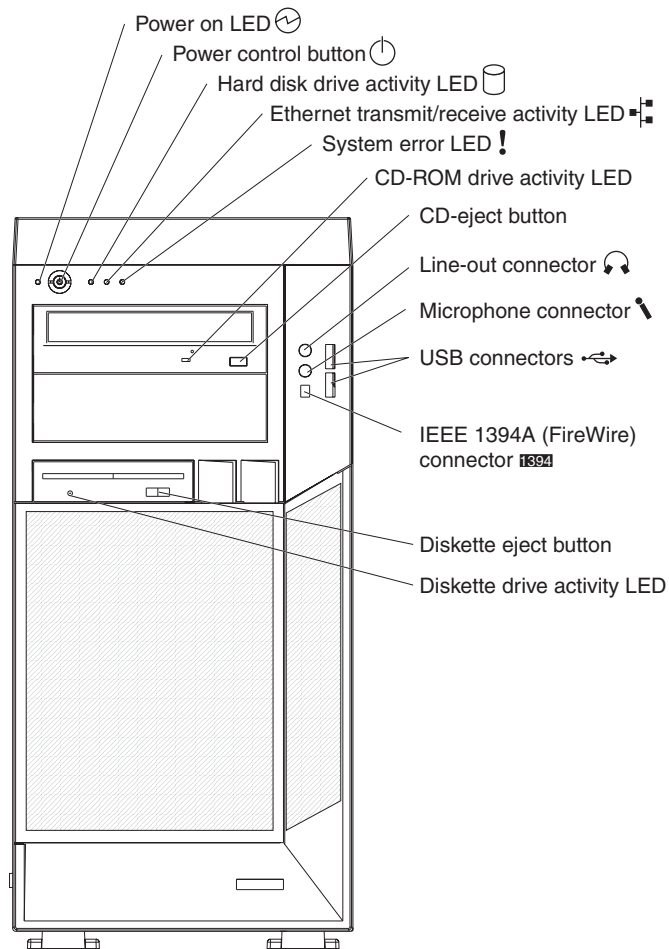

Power-on LED

When this LED is lit and not flashing, it indicates that the computer is turned on. When this LED is flashing, it indicates that the computer is off and still connected to an ac power source (standby mode).

Power-control button

Press this button to turn the computer on or off.

Hard disk drive activity LED

When this LED is lit, it indicates that the hard disk drive is in use.

Ethernet transmit/receive activity LED

When this LED is flickering, it indicates that there is activity between the computer and the network. There are two of these LEDs, one on the front and one on the rear of the computer.

Ethernet link status LED

When this LED is lit, it indicates that there is an active connection on the Ethernet port. This LED is located on the rear of the computer.

System-error LED

When this amber LED is lit, it indicates that a system error has occurred. An LED on the system board is also lit to help isolate the error.

CD-ROM drive activity LED

When this LED is lit, it indicates that the CD-ROM drive is in use.

CD-eject button

Press this button to insert a CD into or remove a CD from the CD-ROM drive.

Line out connector (green)

Use this connector to send audio signals from the computer to external devices, such as speakers with built-in amplifiers, headphones, multimedia keyboards, or the audio line-in jack on a stereo system.

Mic connector (pink)

Use this connector to connect a microphone to your computer when you want to record voices or other sounds on the hard disk. You can also use this connector (and a microphone) with speech recognition software.

USB connectors

Use these connectors to connect USB devices to your computer, using redundant Plug and Play technology.

IEEE 1394A (FireWire) connectors

Use these connectors (four-pin on the front and six-pin on the rear) to connect FireWire devices, such as digital video cameras and external hard disk drives.

Diskette-eject button

Press this button to release a diskette from the diskette drive.

Diskette drive activity LED

When this LED is lit, it indicates that the diskette drive is in use.

Turning on the computer

Note: When you connect the power cord to the computer and an ac power source, the power-supply fan will run and continue to run when the computer is in standby mode to provide cooling to the power supply.

When the computer is connected to an ac power source but is not turned on, the operating system does not run, and all core logic is shut down; however, the computer can respond to remote requests to turn on the computer. The power-on LED flashes to indicate that the computer is connected to an ac power source but is not turned on.

Notes:

1. Turn on all external devices, such as the monitor, before turning on the computer.
2. The power-on LED on the front of the computer is lit when the computer is on and while it is being turned on.

Approximately 20 seconds after the computer is connected to ac power, the power-control button becomes active, and you can turn on the computer and start the operating system by pressing the power-control button. The computer can also be turned on in any of the following ways:

- If a power failure occurs while the computer is turned on, the computer will restart automatically when power is restored.
- When you connect the computer to power for the first time, the Wake on LAN feature can turn on the computer. If the computer was previously turned on, it must be turned off correctly for the Wake on LAN feature to turn on the computer.

What you see and hear when you start the computer depends on the features that are installed and the settings in the Configuration/Setup Utility program.

If the power-on self-test (POST) detects a problem, there might be a series of beeps or no beep, and a numeric error message might appear on the screen. Write down any beep series and error code numbers with descriptions, and then see Chapter 6, "Symptom-to-FRU index," on page 83 for an explanation of the error codes.

Turning off the computer

Note: When you connect the power cord to the computer and an ac power source, the power-supply fan will run and continue to run when the computer is in standby mode to provide cooling to the power supply.

When you turn off the computer and leave it connected to ac power, the computer can respond to requests, such as a remote request to turn on the computer. To remove all power from the computer, you must disconnect it from the power source.

Some operating systems require an orderly shutdown before you turn off the computer. See your operating-system documentation for information about shutting down the operating system.

Statement 5:



CAUTION:

The power control button on the device and the power switch on the power supply do not turn off the electrical current supplied to the device. The device also might have more than one power cord. To remove all electrical current from the device, ensure that all power cords are disconnected from the power source.

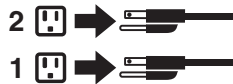

The computer can be turned off in any of the following ways:

- You can turn off the computer through the operating system. If this feature is supported by your operating system, it will turn off the computer after performing an orderly shutdown of the operating system.

If you are using the preinstalled Microsoft Windows XP operating system, complete the following steps to shut down the operating system and computer:

1. Save and close all files that you are working with.
2. Close all open applications.
3. Click **Start**.
4. Click **Turn Off Computer**; then, click **Turn Off** to confirm.

If you are using the preinstalled Red Hat Linux operating system, complete the following steps to shut down the operating system and computer:

1. Save and close all files with which you are working.
2. Close all open applications.
3. Click **Red Hat Linux Main Menu Button** → **Logout** → **Shutdown**.
4. Click **OK** to confirm.

- You can press the power-control button on the front of the computer. It will turn off the computer after performing an orderly shutdown of the operating system, if this feature is supported by your operating system.

Note: After turning off the computer, wait at least 5 seconds before you press the power-control button to turn on the computer again.

- You can press and hold the power-control button for more than 4 seconds to cause an immediate shutdown of the computer. You can use this feature to turn off the computer if the operating system stops functioning.

Chapter 2. Configuring the computer

Detailed information about configuring the computer is in the IBM IntelliStation Z Pro *User's Guide* on the IBM *Documentation CD*.

The latest information about these programs and the most recent device-driver files are available at <http://www.ibm.com/support>.

The following configuration programs are available to configure your computer:

- **Configuration/Setup Utility program**

The Configuration/Setup Utility program is part of the basic input/output system (BIOS) code in your computer. You can use this program to configure serial- and parallel-connector assignments, change interrupt request (IRQ) settings, change the drive startup sequence, set the date and time, and set passwords, and set the chassis-intrusion detector. For more information on how to start this utility, see "Starting the Configuration/Setup Utility program" on page 12. For detailed information, see the *User's Guide*.

- **Boot Menu program**

The Boot Menu program is part of the BIOS code in your computer. Use it to temporarily assign a device to be first in the startup sequence, overriding the startup sequence that is set in the Configuration/Setup Utility program.

- **Broadcom NetXtreme Gigabit Ethernet Boot Agent**

The Broadcom NetXtreme Gigabit Ethernet Boot Agent is part of the BIOS code in your computer. You can use it to configure the network as a startable device, and you can customize where the network startup option appears in your startup sequence. You enable and disable the Broadcom NetXtreme Gigabit Ethernet Boot Agent from the Configuration/Setup Utility program.

- **Adaptec® HostRAID™ configuration programs**

- **Adaptec RAID Configuration Utility programs (for Serial ATA RAID)**

Use the Array Configuration Utility within the Adaptec RAID Configuration Utility programs to configure the integrated Serial ATA (SATA) controller with integrated RAID and the devices that are attached to it.

- **SCSISelect Utility program (for SCSI RAID)**

Use the SCSI HostRAID feature of the SCSISelect Utility program to configure the integrated SCSI controller with integrated RAID and the devices that are attached to it.

- **ServeRAID Manager**

ServeRAID Manager is available as a stand-alone program and as an IBM Director extension. If a ServeRAID controller is installed in your computer, use ServeRAID Manager to define and configure your disk-array subsystem *before* you install your operating system.

- **Ethernet controller configuration**

Use this selection to configure the integrated Gigabit Ethernet controller, see

- **SCSISelect Utility program (some models)**

If your computer has a SCSI adapter installed, you can configure the devices that are connected to the optional SCSI adapter. Use this program to change default values, resolve configuration conflicts, and perform a low-level format on a SCSI hard disk drive.

Starting the Configuration/Setup Utility program

Complete the following steps to start the Configuration/Setup Utility program:

Note: When you use your computer for the first time, you might want to use the Configuration/Setup Utility menu choice **Load Default Settings** to reset the Configuration/Setup Utility menu choices to the factory default settings, in case they were changed before you received the computer. Otherwise, some choices might not appear in the list of menu choices.

1. Turn on the computer and watch the monitor screen. If the computer is already on when you start this procedure, you must shut down the operating system, turn off the computer, wait a few seconds until all in-use LEDs are turned off, and restart the computer.
2. When the message Press F1 for Configuration/Setup appears on the screen during startup, press F1. (This prompt appears on the screen for only a few seconds. You must press F1 quickly.) If you have set both a user password and an administrator password, you must type the administrator password to access the full Configuration/Setup Utility menu.
3. Follow the instructions on the screen.

Chapter 3. Diagnostics

This chapter provides basic troubleshooting information to help solve some common problems that might occur with the computer.

If you cannot locate and correct the problem using the information in this section, see Appendix A, “Getting help and technical assistance,” on page 125 for more information.

General checkout

Follow the checkout procedure for diagnosing hardware problems. Review the following information before performing the checkout procedure:

- Read Appendix B, “Safety information,” on page 127.
- The computer diagnostic programs are stored on the IBM *Enhanced Diagnostics CD*. These programs provide the primary methods of testing the major components of the computer. If you are not sure whether a problem is caused by the hardware or by the software, you can run the diagnostic programs to confirm that the hardware is working correctly.
- When you run the diagnostic programs, a single problem might cause several error messages. If you receive several error messages, correct the cause of the first error message. The other error messages might not occur the next time you run the diagnostic programs.
- Before running the diagnostic programs, you must determine whether the failing computer is part of a shared hard disk drive cluster (two or more servers sharing external storage devices). If you suspect that it is part of a cluster, you can run all diagnostic programs except the ones that test the storage unit (that is, a hard disk drive in the storage unit) or the storage adapter that is attached to the storage unit. The failing server might be part of a cluster if any of the following conditions is true:
 - The customer identifies the failing server as part of a cluster.
 - One or more external storage units are attached to the failing server and at least one of the attached storage units is also attached to another server or unidentifiable device.
 - One or more servers are located near the failing server.
- **Important:**
 1. For servers that are part of a shared hard disk drive cluster, run one test at a time. Do not run any suite of tests, such as “quick” or “normal” tests, because this could enable the hard disk drive diagnostic tests.
 2. If more than one error code is displayed, correct the first error. The other error codes might not occur the next time you run the diagnostic programs.
 3. If the server is suspended and a POST error code is displayed, see “POST error codes” on page 85.
 4. If the server is suspended and no error message is displayed, see “Error symptoms” on page 95 and “Undetermined problems” on page 113.
 5. For information about power-supply problems, see “Power checkout” on page 22.
 6. For intermittent problems, check the error log; see “Diagnostic programs and error messages” on page 16.

Complete the following steps to perform the checkout procedure:

001 IS THE SERVER PART OF A CLUSTER?

YES. Schedule maintenance for the system. Shut down all systems related to the cluster. Run the storage test.

NO. Go to step **002** .

002 IF THE SERVER IS NOT PART OF A CLUSTER:

1. Turn off the server and all external devices.
2. Check all cables and power cords.
3. Set all display controls to the middle position.
4. Turn on all external devices.
5. Turn on the server.
6. Record any POST error messages that are displayed on the screen. If an error is displayed, look up the first error in the "POST error codes" on page 85.
7. Check the system-error log.

Note: The system-error log is available only with the Remote Supervisor Adapter II.

If an error was recorded by the computer, see Chapter 6, "Symptom-to-FRU index," on page 83.

8. Start the diagnostic programs.
9. Check for the following responses:
 - One beep
 - Readable instructions or the main menu

003 DID YOU RECEIVE BOTH OF THE CORRECT RESPONSES?

NO. Find the failure symptom in Chapter 6, "Symptom-to-FRU index," on page 83.

YES. Run the diagnostic programs (see "Starting the diagnostic programs and viewing the test log" on page 17).

If you receive an error, see Chapter 6, "Symptom-to-FRU index," on page 83.

If the diagnostic programs were completed successfully and you still suspect a problem, see "Undetermined problems" on page 113.

Diagnostic tools overview

The following tools are available to help you diagnose and solve hardware-related problems:

- **Computer Support flowchart**

The Computer Support flowchart on the following page will help you determine how to get help from IBM and register your computer.

- **POST beep codes and error messages**

The power-on self-test generates beep codes and messages to indicate successful test completion or the detection of a problem. See "Power-on self-test (POST)" on page 15 for more information. Additional information is recorded in the post error logs.

- **Diagnostic programs**

The system diagnostic programs are on a hidden partition on the hard disk. These programs are the primary methods of testing the major components of your computer. See “Diagnostic programs and error messages” on page 16 for more information.

- **Symptom-to-FRU index**

This index problem symptoms and steps to correct each problem. See the Chapter 6, “Symptom-to-FRU index,” on page 83 for more information.

- **System-board error LEDs**

An LED on the system board might also be lit to help isolate an error indicated by the system error LED on the front of the computer. See “System board error LEDs” on page 74 for more information.

Power-on self-test (POST)

When you turn on the computer, the power-on self-test (POST) performs a series of tests to check the operation of system components and some of the installed options.

If POST finishes without detecting any problems, the first window of your operating system or application program opens.

If POST detects a problem, more than one beep sounds and an error message appears on the screen.

Notes:

1. If you have set a user password, you must type the password and press Enter, when prompted, before the operating system will start.
2. A single problem might cause several error messages. When this occurs, work to correct the cause of the first error message. After you correct the cause of the first error message, the other error messages usually will be resolved the next time you run the test.

POST beep codes

Use the following beep code descriptions to help diagnose and solve problems that are detected during startup:

No beeps

If no beep occurs after the computer completes POST, see Chapter 6, “Symptom-to-FRU index,” on page 83.

Continuous beep

The startup (boot) microprocessor has failed, or the system board or speaker subsystem might contain a failing component. If the computer continues through POST with no errors, got to “General checkout” on page 13 and run the diagnostic programs. If no video appears, the startup processor has failed.

Beep codes for specific failures

Beep codes indicating specific system problems. For a list of beep codes, see “Beep symptoms” on page 83.

POST error messages

POST error messages can appear when a problem is detected during startup. For a complete list of POST messages, see "POST error codes" on page 85.

Diagnostic programs and error messages

Note: When using diagnostics with a USB keyboard and mouse attached, you must first enable USB emulation. Complete the following steps to enable USB emulation:

1. Restart the computer and press F1 to start the Configuration/Setup Utility.
2. Select **Devices and I/O Ports**.
3. Select **USB Setup**.
4. Make sure that the USB keyboard and mouse are enabled.

Diagnostic error messages indicate that there is a problem; they are not intended to be used to identify a failing part. Troubleshooting and servicing complex problems that are indicated by error messages must be performed by trained service personnel.

Sometimes the first error to occur causes additional errors. In this case, the computer displays more than one error message. Always follow the suggested action instructions for the *first* error message that appears.

Text messages

The diagnostic text message format is as follows:

result test_specific_string

where:

result is one of the following results:

Passed

This test was completed without any errors.

Failed This test discovered an error.

User Aborted

You stopped the test before it was completed.

Not Applicable

You attempted to test a device that is not present in the computer.

Aborted

The test could not proceed because of the computer configuration.

Warning

A possible problem was reported during the test (for example, a device that was to be tested is not installed).

test_specific_string

is an error code or other information about the error.

Starting the diagnostic programs and viewing the test log

The IBM Enhanced Diagnostics programs isolate problems from the computer hardware and software. The programs run independently of the operating system. This method of testing is generally used when other methods are not accessible or have not been successful in isolating a problem suspected to be hardware related.

Complete the following steps to view the test log.

Note: If you are already running the Enhanced Diagnostics program, begin with step 4.

1. Start the Enhanced Diagnostics programs.
 - To start the Enhanced Diagnostics programs in a Windows operating system, complete the following steps:
 - a. Restart the computer and when the message To start the Product Recovery program is displayed, quickly press F11.
 - b. Select **System utilities**.
 - c. Select **Run diagnostics** to start the diagnostics programs.
 - To start the Enhanced Diagnostics programs in Red Hat Linux operating system, complete the following steps:
 - a. Restart the computer.
 - b. When the operating system selection menu is displayed, select **IBM Preload Recovery & Diagnostics**.
 - c. Select **Run diagnostics** to start the diagnostics programs.

(Optionally, insert the IBM Enhanced Diagnostics diskette and restart the computer.)

2. Run the applicable diagnostics program and when the Diagnostic Programs screen appears, select **Utility**.
3. Select **View Test Log** from the list; then, follow the instructions on the screen. The test log records data about system failures and other pertinent information. The test log will not contain any information until after the diagnostic program has run.
4. Save the test log to a file on a diskette or to your hard disk.

Notes:

- a. To save the test log to a diskette, you must use a diskette that you have formatted yourself; this function does not work with preformatted diskettes. If the diskette has sufficient space for the test log, the diskette can contain other data.
- b. The system maintains the test-log data only while the Enhanced Diagnostics program is running. When you end the Enhanced Diagnostics program, the test log is cleared.

For a complete list of diagnostic error messages, see “Diagnostic error codes” on page 90.

Small computer system interface (SCSI) messages

If you receive a SCSI error message when running the SCSISelect Utility program, it might be the result of any of the following problems:

- A failing SCSI device (adapter or drive)
- An incorrect SCSI configuration

- Duplicate SCSI IDs in the same SCSI chain
- An incorrectly installed SCSI terminator
- A defective SCSI terminator
- An incorrectly installed cable
- A defective cable

To solve the problem, make sure that:

- The external SCSI devices are turned on. External SCSI devices must be turned on *before* the computer.
- The cables for all external SCSI devices are connected correctly.
- The last device in each SCSI chain is terminated correctly.
- The SCSI devices are configured correctly.

If the problem remains, run the diagnostic programs to obtain additional information about the failing device.

Note: If the computer does not have a SCSI hard disk drive, ignore any message that indicates that the BIOS code is not installed.

PC-Doctor for Windows

Your computer contains PC-Doctor for Windows, which is designed specifically for the Windows operating environment. Because these diagnostics work with the operating system, they test hardware and analyze certain software components. These diagnostic programs are especially useful for isolating operating-system and device-driver problems.

Complete the following steps to use PC-Doctor for Windows:

1. On the Windows desktop, click **Start → All Programs → PC-Doctor**.
2. Follow the instructions on the screen. Help is available online.

Updating (flash-updating) the BIOS code on the computer

Periodically, IBM might post new levels of BIOS code on the Web. Always check the IBM Support Web site at <http://www.ibm.com/support> for the latest level of BIOS code, device drivers, documentation, and hints and tips. You can use one of the following methods to update (flash) the BIOS code on the computer:

- Download the BIOS code update file directly to the hard disk.
- Download the BIOS code update file to a diskette (attach an external Universal Serial Bus [USB] portable diskette drive if you have not installed an integrated diskette drive); then, update the BIOS code on the computer.

You can order an optional IBM USB Portable Diskette Drive such as part number 05K9276. For a list of supported options for your computer, go to <http://www.ibm.com/pc/compat/>.

- Download the BIOS code update file to a CD using a writable optional device (CD-RW drive); then, start the computer with the CD in the CD-ROM drive to update the BIOS code on the computer.

One file is available for each method. The description next to each file indicates the type of medium to which you can download the file. A readme file is available with instructions for installing the BIOS code update.

Complete the following steps to download the BIOS (flash) update files:

1. <http://www.ibm.com/support>.
2. In the **Downloads** category, click **Downloads & drivers**.
3. In the **Brand** field, select **IntelliStation**.
4. In the **Family** field, select **IntelliStation Z Pro**.
5. In the **Type** field, select **6223** and click **Continue**.
6. In the **Filter by category** field, select **BIOS (system)**.
7. Scroll down and select the applicable file for your operating system.
8. Select the file for the type of medium you want to use; then, download the file and install it.
9. Restart the computer.

See the readme file for additional information about how to install the image files.

Note: Always reset the Configuration/Setup Utility program to the default values after updating the BIOS code.

Recovering from a POST/BIOS update failure

Notes:

1. You can download a file to create the POST/BIOS recovery diskette or CD from <http://www.ibm.com/support> on the World Wide Web. For more information, see Appendix A, "Getting help and technical assistance," on page 125.
2. To create and use a diskette, you must add a diskette drive to your computer. To enable a USB diskette drive, follow these steps:
 - a. Enable the **Legacy USB Support** option under the **Startup Option** menu choice in the Configuration/Setup Utility program.
 - b. Set your removable media device as the first startup device.
 - c. Select the removable media device you want to boot from and move it to the top of the Removable Devices list.

If power to your computer is interrupted while POST/BIOS code is being updated (flash update), the computer might not restart (reboot) correctly or might not display video (no video). If this happens, complete the following steps:

1. Review the safety information beginning on page 127 and "Handling static-sensitive devices" on page 23.
2. Turn off the computer and all attached devices.
3. Disconnect the power cord.
4. Remove the cover and support bracket.
5. Locate the boot block recovery jumper (JCON1) on the system board. The following illustration shows the location of the boot block jumper on the system board.

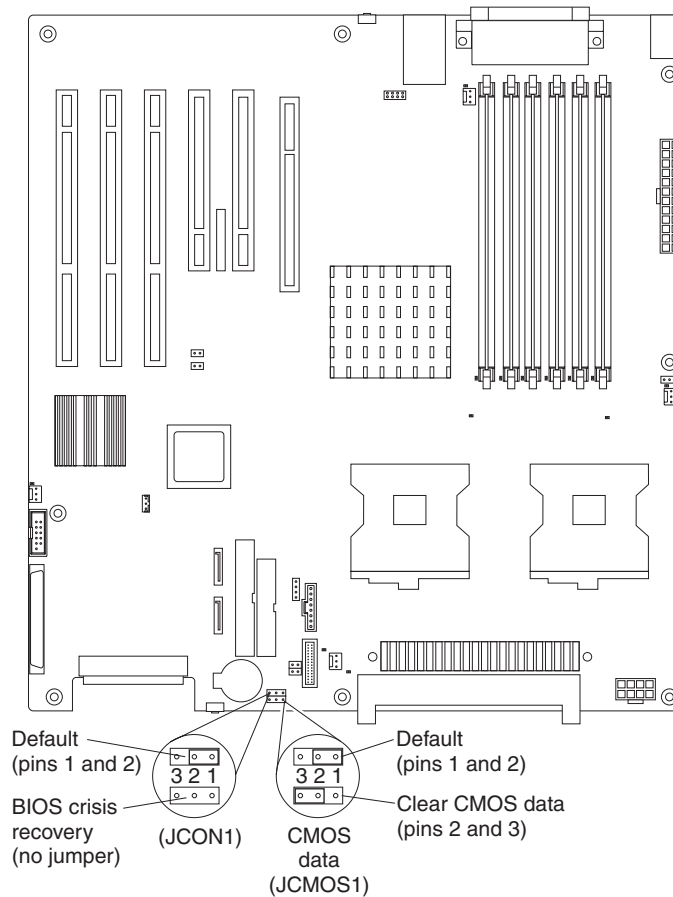

6. Remove the boot block recovery jumper from pins 1 and 2.
7. Replace any adapters that were removed; then, replace the support bracket and replace the cover.
8. Connect the computer to a power source, keyboard, monitor, and mouse.
9. Insert the POST/BIOS update (flash) recovery diskette or CD into the diskette drive or CD-ROM drive.
10. Turn on the computer and the monitor.
11. After the update session is completed, turn off the computer and monitor.
12. Remove the diskette or CD from the diskette drive or CD-ROM drive.
13. Disconnect all power cords; then, remove the computer cover.
14. Return the boot block recovery jumper to pins 1 and 2.
15. Replace the computer cover; then, reconnect all external cables and power cords and turn on the peripheral devices.
16. Turn on the computer to restart the operating system.

Erasing a lost or forgotten password (clearing CMOS)

This section applies to lost or forgotten passwords. More information about lost or forgotten passwords is available in Access IBM.

Complete the following steps to set the CMOS recovery jumper and erase a forgotten password:

1. Review the safety information beginning on page 127 and “Handling static-sensitive devices” on page 23.

2. Turn off the computer and all attached devices.
3. Disconnect the power cord.
4. Remove the side cover and support bracket.
5. Locate the CMOS recovery jumper (JCMOS1) on the system board, removing any adapters that impede access to the jumper. An illustration showing the location of the jumper on the system board is in "Recovering from a POST/BIOS update failure" on page 19.
6. Move the CMOS recovery jumper from pins 1 and 2 to pins 2 and 3.
7. Wait 60 seconds; then, return the CMOS recovery jumper to pins 1 and 2.
8. Replace any adapters that were removed; then, replace the support bracket and replace the side cover.

You can now start the computer one time, and start the Configuration/Setup Utility program, without having to use the power-on password. At this time, you can either delete the old password or set a new user password. If you do not change or delete the password, the next time you start the computer the original user password will be reinstated.
9. Connect the computer to a power source, keyboard, monitor, and mouse.
10. Turn on the computer. The Configuration/Setup Utility program starts.
11. Follow the instructions to erase the existing password or create a new password.
12. Select **Save Settings** and press Enter.

Replacing the battery

When replacing the battery, you must replace it with a lithium battery of the same type from the same manufacturer. To avoid possible danger, read and follow the information in Appendix B, "Safety information," on page 127.

To order replacement batteries, call 1-800-426-7378 within the United States, and 1-800-465-7999 or 1-800-465-6666 within Canada. Outside the U.S. and Canada, call your IBM marketing representative or authorized reseller.

Note: After you replace the battery, you must reconfigure the computer and reset the system date and time.

Complete the following steps to replace the battery:

1. Review the safety information beginning on page 127 "Installation guidelines" on page 23, and "Handling static-sensitive devices" on page 23..
2. Follow any special handling and installation instructions that come with the replacement battery.
3. Turn off the computer and all attached devices. Disconnect all external cables and power cords; then, remove the computer cover and the support bracket. (See "Removing the side cover" on page 25)
4. Remove the battery:
 - a. Use a fingernail to press the top of the battery clip away from the battery. The battery pops up when released.
 - b. Use your thumb and index finger to lift the battery from the socket.

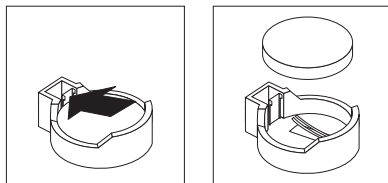

5. Insert the new battery:
 - a. Tilt the battery so that you can insert it into the socket on the side opposite the battery clip.
 - b. Press the battery down into the socket until it clicks into place. Make sure that the battery clip holds the battery securely.

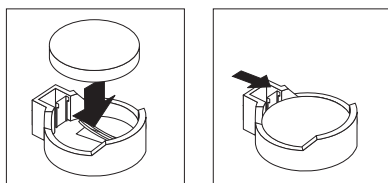

6. Replace the cover and connect the cables.
7. Turn on the computer.
8. Start the Configuration/Setup Utility program and set configuration parameters.
 - Set the system date and time.
 - Set passwords if necessary.
 - Save the configuration.

Power checkout

Power problems can be difficult to solve. For example, a short circuit can exist anywhere on any of the power-distribution buses. Usually, a short circuit will cause the power subsystem to shut down because of an overcurrent condition.

A general procedure for troubleshooting power problems is as follows:

1. Turn off the server, and disconnect all ac power cords.
2. Check for loose cables in the power subsystem. Also check for short circuits, for example, if there is a loose screw causing a short circuit on a circuit board.
3. Remove adapters and disconnect the cables and power connectors to all internal and external devices until the server is at the minimum configuration required to start the server (see, "Minimum operating requirements" on page 113).
4. Reconnect all ac power cords and turn on the server. If the server starts successfully, replace adapters and devices one at a time until the problem is isolated. If the server does not start from the minimal configuration, replace FRUs of the minimal configuration one at a time until the problem is isolated.

To use this method, you must know the minimum configuration that is required for the server to start (see page 103).

Chapter 4. Installing options

This chapter provides instructions for installing or replacing hardware options in your computer. For a list of supported options for your computer, go to <http://www.ibm.com/pc/>; then, select your country and navigate to the list of options for your computer.

Installation guidelines

Before you begin installing options in your computer, read the following information:

- Read the safety information beginning on page 127 and the guidelines in “Handling electrostatic discharge-sensitive devices” on page 130.. This information will help you work safely with your computer and options.
- Make sure that you have an adequate number of properly grounded electrical outlets for your computer, monitor, and other devices that you will connect to the computer.
- Back up all important data before you make changes to disk drives.
- Have a small flat-blade screwdriver available.
- When you need to access the inside of the computer to install options, you might find it easier to lay the computer on its side.
- Blue on a component indicates touch points, where you can grip the component to remove it from or install it in the computer, open or close a latch, and so on.

System reliability considerations

To help ensure proper cooling and system reliability, make sure that:

- Each of the drive bays has a drive or a filler panel and electromagnetic compatibility (EMC) shield installed in it.
- There is adequate space around the computer to allow the computer cooling system to work properly. Leave approximately 50 mm (2 in.) of open space around the front and rear of the computer. Do not place objects in front of the fans. For proper cooling and airflow, replace the computer cover before turning on the computer. Operating the computer for extended periods of time (more than 30 minutes) with the computer cover removed might damage computer components.
- You have followed the cabling instructions that come with optional adapters.
- You have replaced a failed fan as soon as possible.

Handling static-sensitive devices

Attention: Static electricity can damage electronic devices and your computer. To avoid damage, keep static-sensitive devices in their static-protective packages until you are ready to install them.

To reduce the possibility of damage from electrostatic discharge, observe the following precautions:

- Limit your movement. Movement can cause static electricity to build up around you.
- Handle the device carefully, holding it by its edges or its frame.
- Do not touch solder joints, pins, or exposed circuitry.
- Do not leave the device where others can handle and damage it.

- While the device is still in its static-protective package, touch it to an unpainted metal part of the computer for at least 2 seconds. This drains static electricity from the package and from your body.
- Remove the device from its package and install it directly into the computer without setting down the device. If it is necessary to set down the device, put it back into its static-protective package. Do not place the device on your computer cover or on a metal surface.
- Take additional care when handling devices during cold weather. Heating reduces indoor humidity and increases static electricity.

Installing options in your computer

This section provides instructions for installing hardware options in your computer.

Note: To remove the side cover and install options, you might find it easier to lay the computer on its side.

Major components of your computer

The following illustration shows the major components in the Z Pro Type 6223 computer.

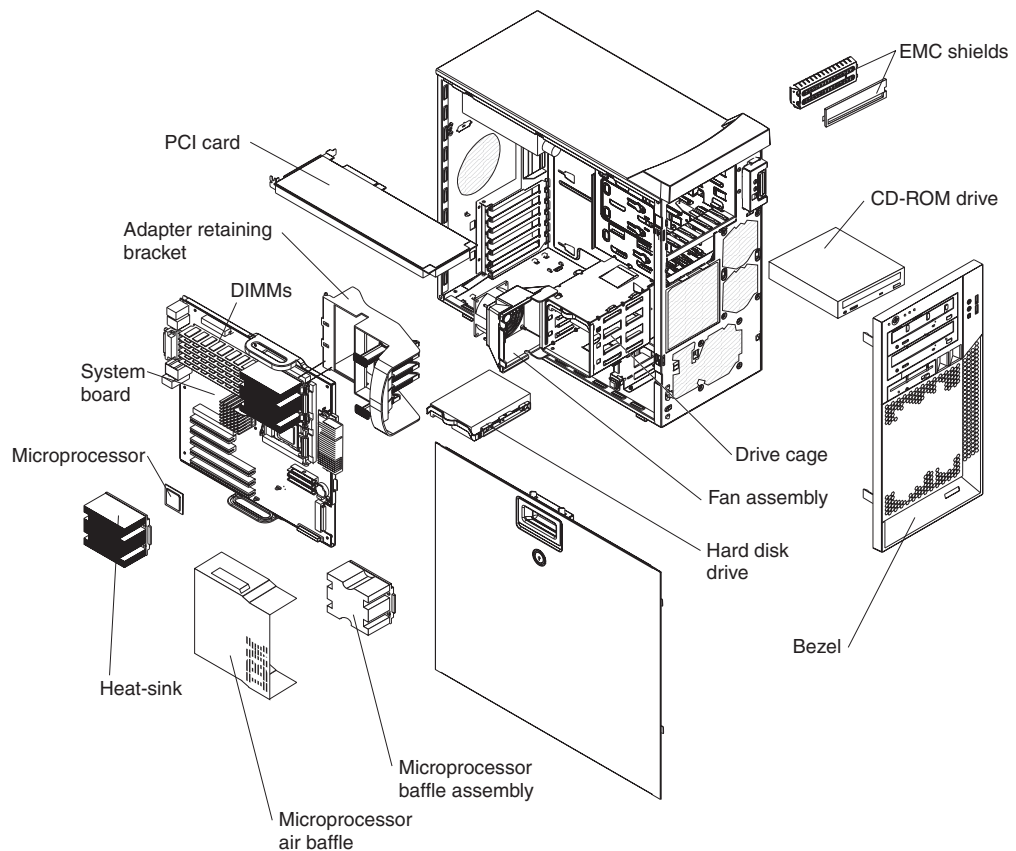

Removing the side cover

To remove the cover, you might find it easier to lay the computer on its side.

Complete the following steps to remove the side cover of the computer:

1. Review the “Installation guidelines” on page 23.
2. Turn off the computer and all attached devices (see “Turning off the computer” on page 9); then, disconnect all power cords and external cables.
3. Pull down on the cover-release handle; then, pull the cover straight up and lift the side cover off the computer and set it aside.

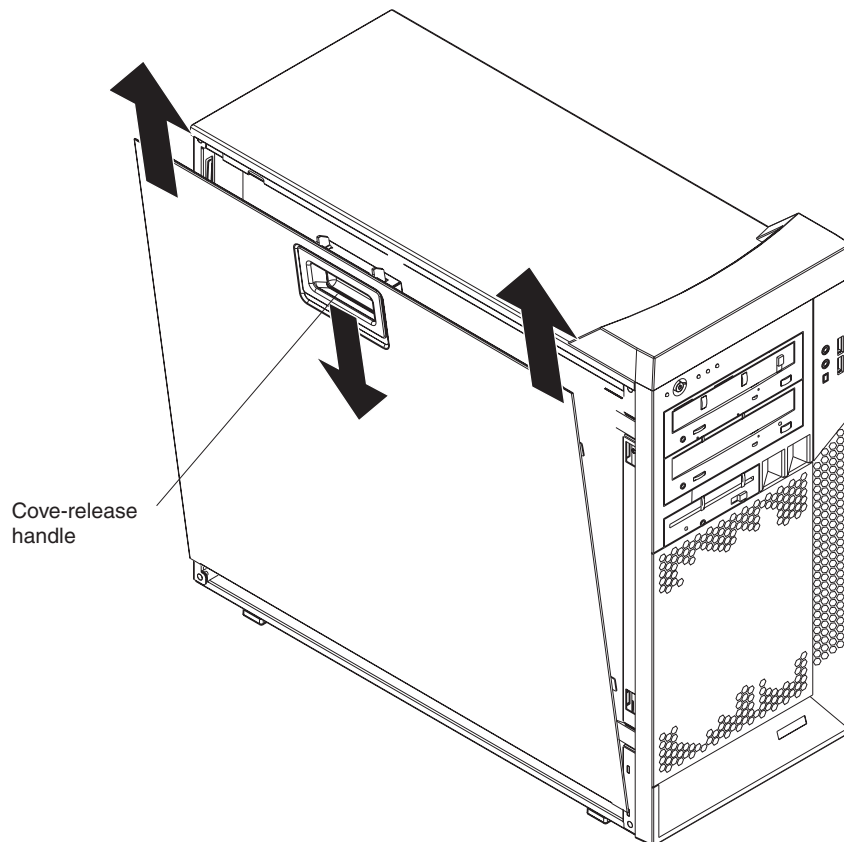

To replace the side cover, see “Replacing the side cover” on page 51.

Attention: For proper cooling and airflow, replace the side cover before turning on the computer. Operating the computer with the cover removed might damage computer components.

Removing the bezel

When working with some devices, such as additional optical drives, you must first remove the bezel to access the device. To install or remove options, you might find it easier to lay the computer on its side.

Complete the following steps to remove the bezel:

1. Unlock the side-cover lock.
2. Remove the side cover (see “Removing the side cover” on page 25).
3. Locate the two bezel clips that are securing the bezel to the computer chassis. Gently lift and hold the bezel clips up and at the same time, rotate the bezel outward to disengage it from the side tabs; then, set the bezel aside.

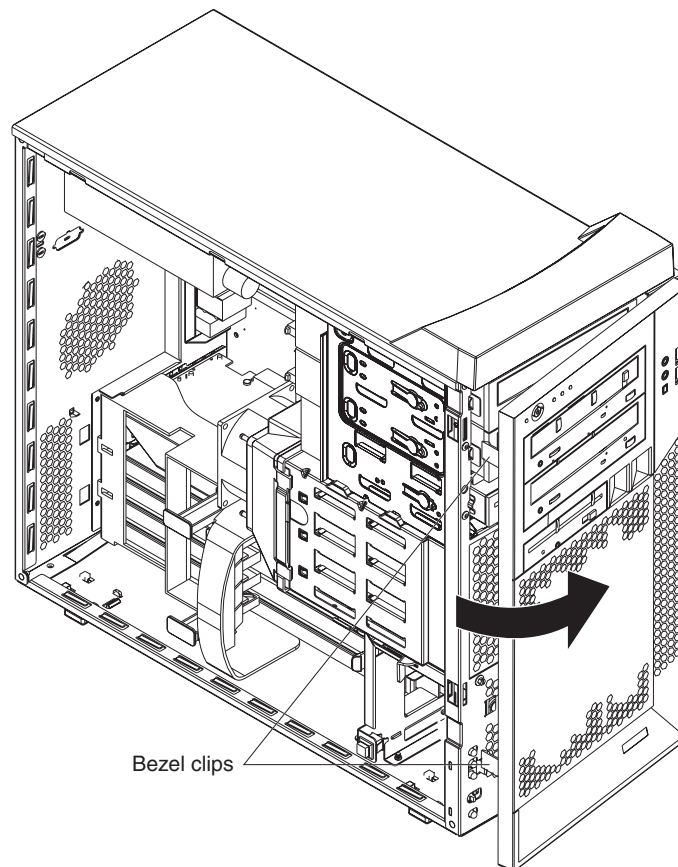

For instructions for replacing the bezel, see “Replacing the bezel” on page 50.

Installing an adapter

The following notes describe the types of adapters that your computer supports and other information that you must consider when installing an adapter. See “System board option connectors” on page 71 for an illustration of the adapter slot locations.

- Read the documentation that comes with your operating system.
- Locate the documentation that comes with the adapter and follow those instructions in addition to the instructions in this chapter. If you need to change the switch or jumper settings on your adapter, follow the instructions that come with the adapter.

- Your computer comes with adapter connectors or *slots*. The video adapter is installed in the PCI Express x16 slot (slot 1). You can install up to five additional adapters in your computer in PCI slots 2 and 3, and PCI-X slots 4, 5, and 6.
- You can install full-length adapters in PCI slot 3, and PCI-X slots 4, 5, and 6. However, a full-length adapter will not fit in PCI slot 2 and is not supported. None of the expansion slots are hot-plug slots.
- Your computer supports 5.0 V signaling and universal PCI 32-bit/33 MHz adapters in PCI slots 2 and 3.
- Your computer supports 3.3 V signaling and universal PCI-X 64-bit/133 MHz adapters in PCI-X slot 4.
- Your computer supports 3.3 V signaling and universal PCI-X 64-bit/100 MHz adapters in PCI-X slot 5 and 6.
- Your computer uses a rotational interrupt technique to configure PCI adapters, which means that you can install a variety of PCI adapters that currently do not support sharing of PCI interrupts.
- If you install a ServeRAID 6i+ adapter, it must be installed in PCI-X slot 5.
- If you install an optional RAID adapter in your computer, you must reinstall the operating system and applications that came preinstalled on your computer.
- The system scans the PCI Express x16 slot (slot 1), PCI expansion slots 2 and 3, and PCI-X expansion slots 4 through 6 to assign system resources. Then, it starts the PCI devices in the following order, if you have not changed the default startup sequence: PCI Express x16 slot (slot 1), system-board integrated drive electronics (IDE), Serial ATA (SATA), or small computer system interface (SCSI) devices (including optional ServeRAID-6i+ controller), and then PCI-X slots 4 through 6.
- For a list of supported options for your computer, go to <http://www.ibm.com/pc/>; then, select your country and navigate to the list of options for your computer.

Complete the following steps to install an adapter in your computer:

1. Read the safety information beginning on page 127 and the guidelines in “Handling static-sensitive devices” on page 23
2. Turn off the computer and all attached devices (see “Turning off the computer” on page 9); then, disconnect all external cables and power cords.
3. Remove the side cover (see “Removing the side cover” on page 25).
4. Determine the slot in which you want to install the adapter. Review the instructions that come with the adapter for any requirements, restrictions, or cabling instructions. It might be easier to route any cables before you install the adapter.
5. For full-length adapters, rotate the rear adapter-retention bracket to the open (unlocked) position (you might have to first remove any adapters that might be in the way). Press down on the bottom tab of the front adapter-retention bracket to release it (the tab is inside the fan compartment that is next to the front adapter-retention bracket). If you are installing a smaller adapter, rotate only the rear adapter-retention bracket.

6. Remove the expansion-slot cover. From the rear of the computer, press on the slot cover. Grasp it and pull it out of the expansion slot. Store it in a safe place for future use.

Attention: Expansion-slot covers must be installed on all empty slots. This maintains the electronic emissions standards of the computer and ensures proper ventilation of computer components.

7. Follow the instructions that come with the adapter to set jumpers or switches, if any.

Attention: Avoid touching the components and gold-edge connectors on the adapter.

8. If you are installing a full-length adapter, remove the blue adapter guide (if any) from the end of the adapter.

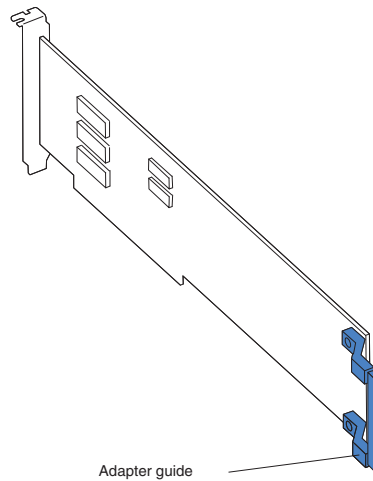

Attention: Be certain that the adapter is correctly seated in the expansion slot before you turn on the computer. Incomplete installation of an adapter might damage the system board or the adapter.

- Carefully grasp the adapter by the top edge or upper corners and move the adapter directly from the static-protective package to adapter slot (avoid touching the components and gold-edge connectors on the adapter). Align the adapter with the expansion slot guides; then, press the adapter *firmly* into the expansion slot.

Attention: Make sure that the adapter is correctly seated in the expansion slot before you turn on the computer. Incomplete installation of an adapter might damage the system board or the adapter.

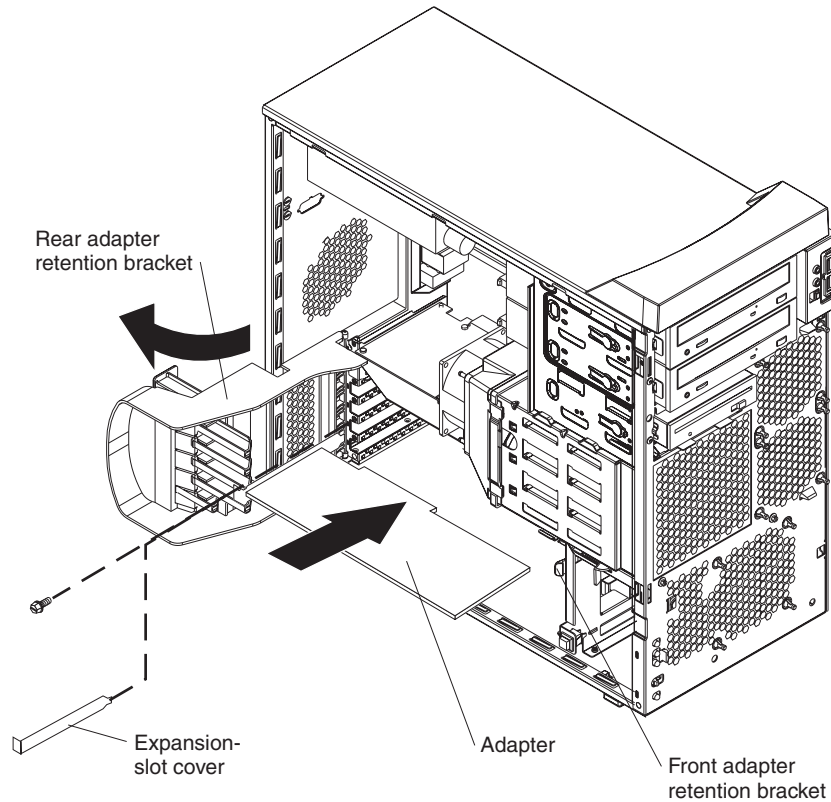

- Connect required cables to the adapter. Route cables so that they do not block the flow of air from the fans. If you are installing an optional SCSI adapter, see “Cabling an optional SCSI adapter” on page 30 for additional information.
- If you have another adapter to install, repeat steps 4 through 10.
- If you have installed a full-length adapter, press down on the top tab of the front adapter-retention bracket to lock it in place (the tab is inside the fan compartment that is next to the front adapter-retention bracket).

Note: If any adapter in your computer is large or has heavy cables attached to it, you can secure the adapter with a screw. Insert one backup expansion-slot screw (the screws are stored directly above the front adapter-retention bracket) through the top of each adapter bracket into the screw hole and secure the adapter before proceeding to the next step.

- If you have other options to install, do so now; otherwise, replace the side cover (see “Replacing the side cover” on page 51), reconnect the external cables and power cords, and turn on the computer.

Cabling an optional SCSI adapter

You can install an optional SCSI adapter in your computer to control the internal hard disk drives and provide additional RAID capabilities. With a SCSI adapter installed, you can configure the internal hard disk drives into disk arrays. You can also cable a SCSI adapter to external hard disk drives. See your SCSI adapter option documentation for complete instructions for installing a SCSI adapter in your computer and for additional information about SCSI adapters.

Notes:

1. The SCSI cables that are used by the integrated SCSI controller cannot be used with an optional SCSI adapter.
2. If you install a ServeRAID 6i+ adapter, it must be installed in slot 5; no cabling is required for this adapter.

Complete the following steps to cable an optional SCSI adapter:

1. Install the SCSI adapter (see “Installing an adapter” on page 26).
2. Connect the SCSI-signal cable to the adapter and one or more of the signal cable connectors to the rear of the SCSI devices.
3. Connect the SCSI-activity-indicator cable to the adapter and to the SCSI-LED connector on the system board. See “System board internal connectors” on page 72 for the location of the SCSI-LED connector.

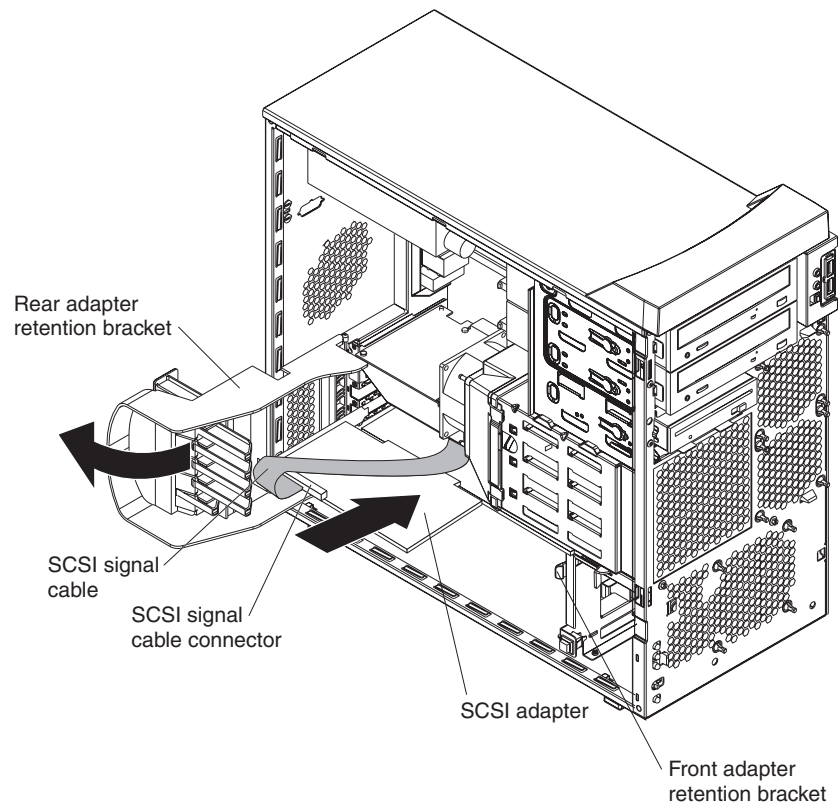

4. Complete the installation of the optional SCSI adapter.

Installing a drive

Depending on your computer model, one or more of the following drives might be installed in your computer:

- Diskette drive (optional)
- Hard disk drive
- CD-ROM, CD-RW, or DVD/CD-RW combo drive

Your Z Pro Type 6223 computer comes with an IDE CD-ROM drive in bay 1 and a hard disk drive in bay 4.

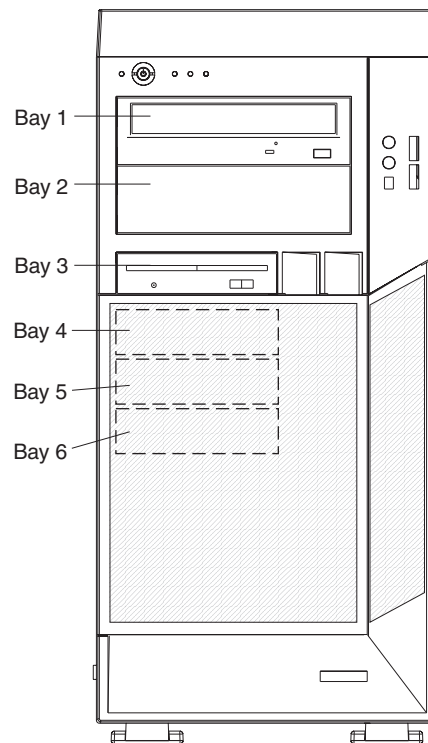

The following notes describe the types of drives that your computer supports and other information that you must consider when installing drives:

- Make sure that you have all the cables and other equipment specified in the documentation that comes with the drive.
- Select the bay in which you want to install the drive.
- Check the instructions that come with the drive to see whether you need to set any switches or jumpers on the drive. If you are installing a SCSI device, be sure to set the SCSI ID for that device.
- You can install removable-media drives in bays 1, 2, and 3 only. Tape drives, diskette drives, CD-ROM, DVD/CD-RW, and DVD-ROM drives are examples of removable-media drives.
- You can install a 3.5-in. slim-high or 5.25-in. half-high removable-media drive, such as a tape backup drive, in bay 2.
- You can install a diskette drive or a 3.5-in slim-high hard disk drive in bay 3.
- To install a 3.5-in. drive in a 5.25-in. bay, you must use the 5.25-in. conversion kit.
- Your computer supports only one diskette drive: either a diskette drive in bay 3 or a USB drive connected to the USB connector on the front of the computer.

- Two Serial ATA hard disk drive connectors are on the system board.
- If you install SCSI hard disk drives and SATA hard disk drives in the same computer, note the following HostRAID considerations for hard disk drives:
 - You can enable HostRAID on only one subsystem (SCSI or SATA).
 - If HostRAID is enabled on a subsystem, you can install boot hard disk drives on that subsystem only.

If you fail to observe these restrictions, the computer will usually disable the BIOS for the last subsystem loaded, which typically is SCSI.

For more information about HostRAID, see in the User's Guide.

- The electromagnetic interference (EMI) integrity and cooling of the computer are protected by having all bays, PCI, and PCI-X slots covered or occupied. When you install a drive, PCI adapter, or PCI-X adapter, save the EMC shield and filler panel from the bay or the adapter slot cover in the event you later remove the drive or adapter.
- For a complete list of supported options for your computer, go to <http://www.ibm.com/pc/>; then, select your country and navigate to the list of options for your computer.

Installing a drive in bay 2 or 3

Complete the following steps to install a drive in bay 2 or 3:

1. Read the safety information beginning on page 127 and “Installation guidelines” on page 23.
2. Turn off the computer and peripheral devices, and disconnect the power cords and all external cables.
3. Remove the side cover (see “Removing the side cover” on page 25).
4. Remove the bezel (see “Removing the bezel” on page 26).

5. Use a screwdriver to pry the filler panel and EMC shield away from the computer.

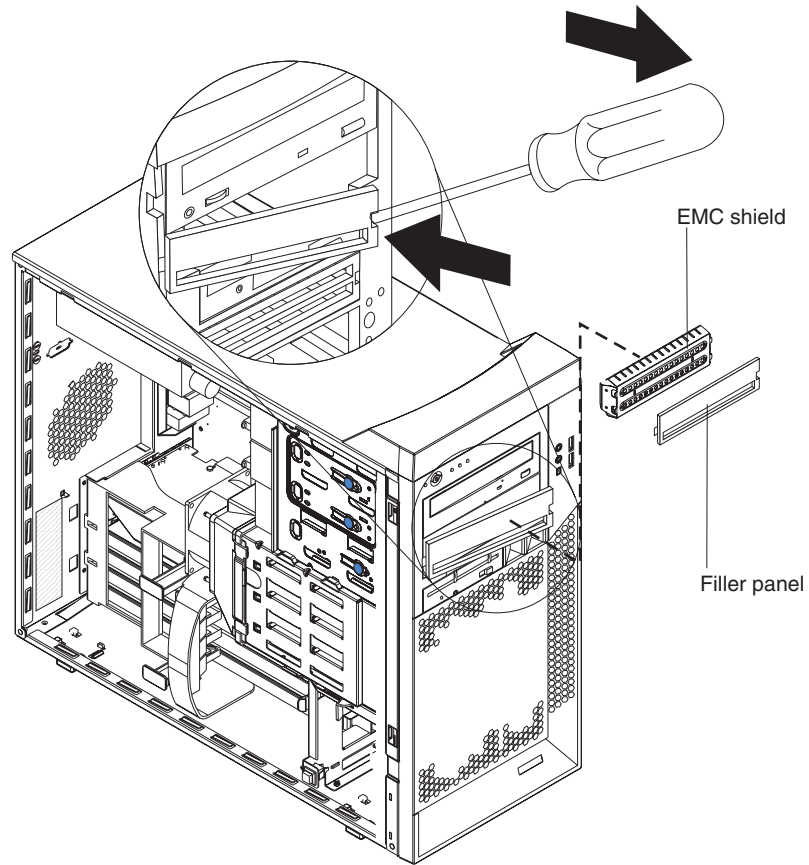

Note: If you are installing a drive that contains a laser, observe the following safety precaution.

Statement 3



CAUTION:

When laser products (such as CD-ROMs, DVD drives, fiber optic devices, or transmitters) are installed, note the following:

- Do not remove the covers. Removing the covers of the laser product could result in exposure to hazardous laser radiation. There are no serviceable parts inside the device.
- Use of controls or adjustments or performance of procedures other than those specified herein might result in hazardous radiation exposure.



Danger

Some laser products contain an embedded Class 3A or Class 3B laser diode. Note the following. Laser radiation when open. Do not stare into the beam, do not view directly with optical instruments, and avoid direct exposure to the beam.

Class 1 Laser Product

Laser Klasse 1

Laser Klass 1

Luokan 1 Laserlaite

Appareil À Laser de Classe 1

6. Touch the static-protective package containing the drive to any unpainted metal surface on the computer; then, remove the drive from the package and place it on a static-protective surface.
7. Set any jumpers or switches on the drive according to the documentation that comes with the drive.

Note: You might find it easier to install the new drive from the front and then attach the cables.

8. To install a drive in bay 2, complete the following steps:
 - a. Remove the large drive clip attached to the side of bay 2 of the drive cage for bays 1, 2, and 3 (see the figure below). Slide the drive clip to the left to disengage it from the drive cage; then, snap the drive clip into the screw holes on the side of the drive.

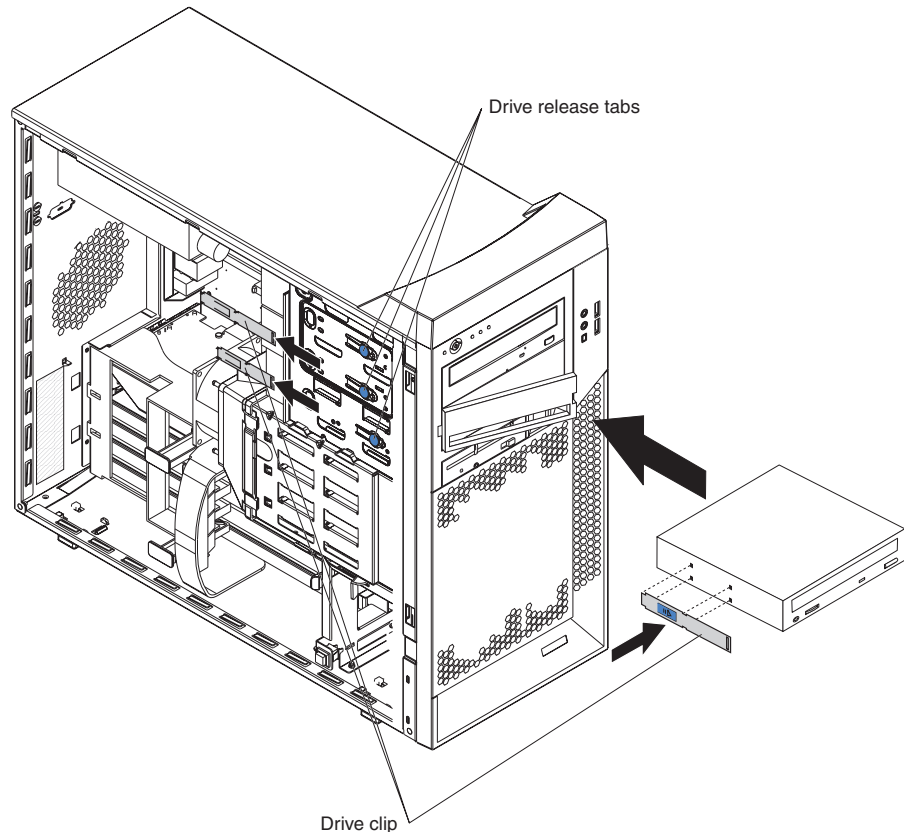

- b. If you are installing a 5.25-in. drive in bay 2, slide the drive into the drive bay until it snaps in place. If you are installing a 3.5-in. drive in bay 2, you must attach the 5.25-in. conversion kit, which you can order from IBM, to the 3.5-in. drive.
 - c. Continue with step 10.
9. To install a drive in bay 3, use one of the following procedures:

Note: Only a 3.5-in. device can be installed in bay 3.

- If you are installing an external media device in bay 3, complete the following steps:
 - a. Remove the small drive clip that is attached to the side of bay 3 of the drive cage for bays 1, 2, and 3 (see the figure above). Slide the drive clip to the left to disengage it from the drive cage; then, snap the drive clip into the screw holes on the side of the drive.
 - b. Slide the drive into the drive bay until it snaps in place.
 - c. Continue with step 10.
- If you are installing a hard disk drive in bay 3, complete the following steps:
 - a. Push the drive into the bay from the rear of the drive cage; then, use the two screws to attach the drive to the drive cage.
 - b. Continue with step 10.

10. Determine whether the drive is an IDE or SCSI device; then, connect one end of the applicable signal cable into the back of the drive and make sure that the other end of this cable is connected into the applicable IDE or SCSI connector on the system board.
11. Route the signal cable so that it does not block the airflow to the rear of the drives or over the microprocessor and memory.
12. If you have another drive to install or remove, do so now.
13. Connect the power cable to the back of the drive. The connectors are keyed and can be inserted only one way.
14. If you have other options to install or remove, do so now; otherwise, replace the bezel (see “Replacing the bezel” on page 50) and replace the side cover (see “Replacing the side cover” on page 51).

Installing a SCSI or SATA drive in bay 4, 5, or 6

Some models come with non-hot-swap SCSI hard disk drives or Serial ATA (SATA) hard disk drives. Before you install a hard disk drive in bays 4, 5, and 6, read the following information:

- Read the documentation that comes with the drive for cabling instructions.
- Route the cable before you install the drive. Do not block the airflow from the fans.
- You can install up to four SCSI hard disk drives in your computer (SCSI models only).
- Your computer supports up to two Serial ATA hard disk drives.

Note: Your computer can support a third and fourth SATA drive if you install an optional ServeRAID-7t S-ATA controller. In addition, if you install the optional ServeRAID-7t S-ATA controller to add a third and fourth drive, all four SATA drives must then be connected to the ServeRAID-7t S-ATA controller instead of the system board. See the optional ServeRAID-7t S-ATA controller documentation for cabling instructions.

If you purchase a new SATA hard drive, you will also need to purchase a signal cable for it. IBM SATA hard drive option comes with a signal cable.

- Install hard disk drives in this sequence: bay 4, bay 5, bay 6, and then bay 3. See “Installing a drive in bay 2 or 3” on page 32 for information about how to install a hard disk drive in bay 3.

Complete the following steps to install a SCSI or Serial ATA (SATA) hard disk drive:

1. Read the safety information beginning on page 127 and the “Installation guidelines” on page 23.
2. Turn off the computer and peripheral devices and disconnect all external cables and power cords.
3. Unlock the side cover.
4. Remove the side cover (see “Removing the side cover” on page 25).
5. Disconnect the fan connector for the fan that is attached to the back of the drive cage from the system board.
6. Press in on the drive-cage release lever and rotate the drive cage all the way out of the computer until it locks into place over the drive-cage retention tab. The open ends of the drive slots and installed drives will face you.

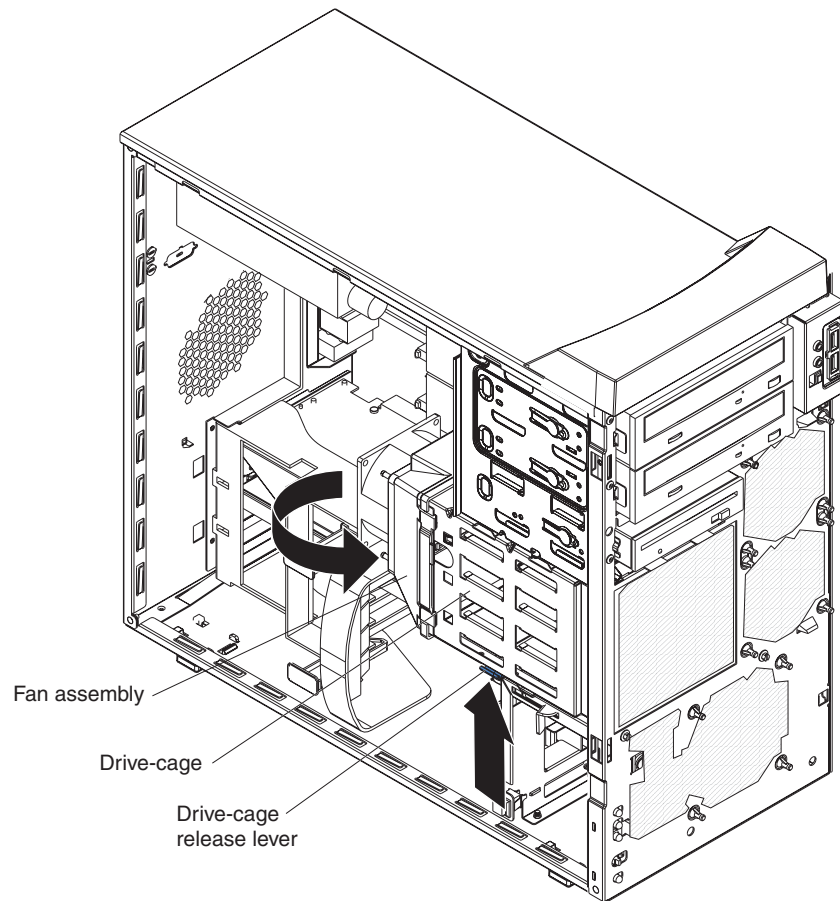

7. Grasp the fan latch on the fan assembly that is over the drive cage and pull it outward to disengage it from the drive cage and rotate it to the side.

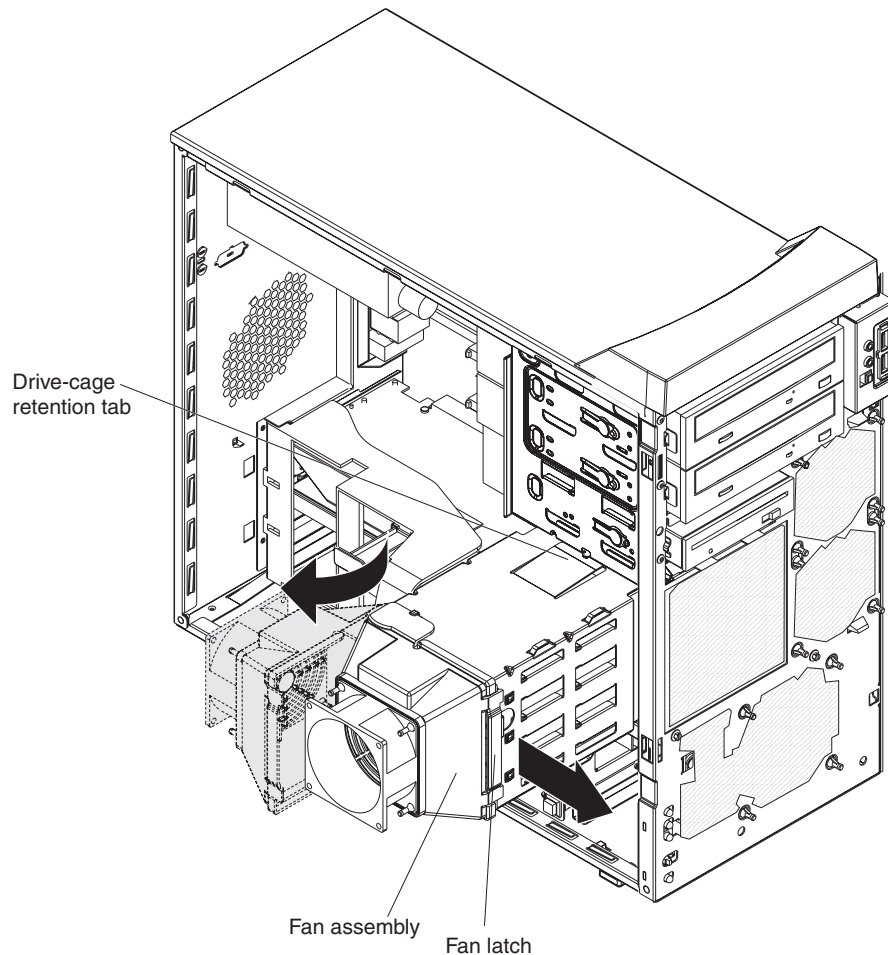

8. If your computer has preinstalled hard disk drives in the drive cage, disconnect the power and signal cables from the rear of the drives.
9. Remove the empty drive tray from the drive bay in which you want to install the drive.
10. Touch the static-protective package containing the drive to any unpainted metal surface on the computer; then, remove the drive from the package and place it on a static-protective surface.
11. Set any jumpers or switches on the drive according to the documentation that comes with the drive.

12. Attach the new drive to the drive tray. Place the drive on the drive tray and align the holes on the drive with the mounting pins on the drive tray. Gently pull both sides of the drive tray outward and insert the mounting pins into the holes on the drive.

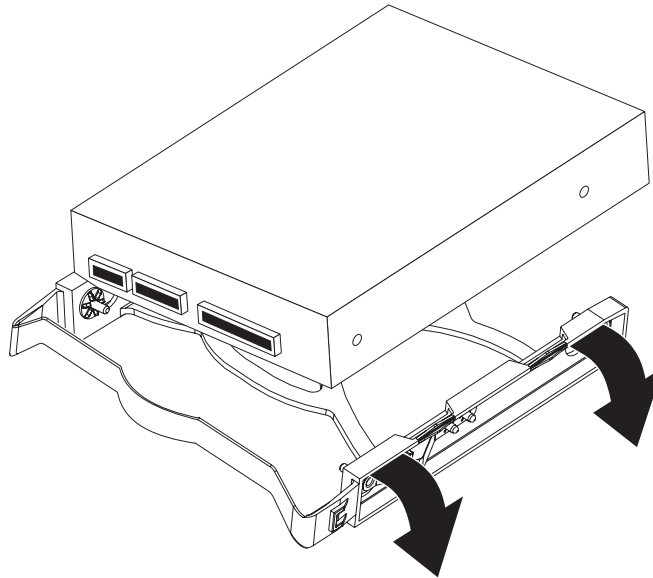

13. Align the drive assembly with the guide rails in the bay (make sure that the connector end of the drive is facing you).
14. Gently slide the drive assembly into the drive bay until the drive snaps into place.
15. Determine whether the new drive is a Serial ATA or SCSI device; then, connect one end of the applicable signal cable into the back of the drive and the other end of this cable into the applicable Serial ATA or SCSI connector on the system board. See "Power and signal cables for internal drives" on page 40 for additional information about cabling drives and "System board internal connectors" on page 72 for the location of the Serial ATA and SCSI connectors on the system board. If there are open connectors on the cables connecting existing Serial ATA or SCSI drives, you can use these cables to connect the new drive.
16. Route the signal cable so that it does not block the airflow to the rear of the drives or over any microprocessor.
17. Connect the power cables to the back of the drives. The connectors are keyed and can be inserted only one way.
18. Push the drive cage outward, and press in on the drive-cage release tab; then, rotate the drive cage back into the computer.
19. Reconnect the connector for the fan that is attached to the back of the drive cage to the system board.
20. If you have other options to install or remove, do so now. Otherwise, replace the side cover (see "Replacing the side cover" on page 51).
21. Reconnect the external cables and power cords; then, turn on the attached devices and the computer.

Power and signal cables for internal drives

Your computer uses cables to connect IDE, Serial ATA, and SCSI devices to the power supply and to the system board. (See “System board internal connectors” on page 72 for the location of system-board connectors.) Review the following information before connecting power and signal cables to internal drives:

- The drives that are preinstalled in your computer come with power and signal cables attached. If you replace any drives, remember which cable is attached to which drive, or label the cables.
- When you install a drive, make sure that one of the signal-cable connectors is connected to the drive and that the connector at the other end of the signal cable is connected to the system board.
- The computer has one IDE bus, which is primary.
- If you have only one IDE device on a cable, it must be set as a master device.

The following cables are provided:

- **Power cables:** Four-wire power cables connect the drives to the power supply. At the end of these cables are plastic connectors that attach to different drives; these connectors vary in size. With Serial ATA drives, you can use either a four-wire power cable or a five-wire Serial ATA power cable, but do not use both at the same time (use one or the other).
- **Signal cables:** Signal cables typically are flat cables, also called ribbon cables, that connect IDE, Serial ATA, SCSI, and diskette drives to the system board. Two or three types of signal cables come with your computer:

- **IDE:** The wider IDE signal cable has three connectors. One of these connectors is attached to the drive, one is a spare, and the third is attached to the primary or secondary IDE connector on the system board. The spare connector can be used to connect additional IDE drives to your computer.

Note: The optical drive is attached to an ATA 100 signal cable. ATA 100 signal cables are color-coded. The blue connector is connected to the system board. The black connector is connected to the master IDE device. The gray middle connector is connected to the subordinate IDE device.

- **Serial ATA:** The narrower, black signal cable has two connectors. One is connected to the SATA drive, and the other is connected to the connector on the system board. Each SATA drive comes with a cable. If you install an additional SATA drive, you will need an additional cable.
- **SCSI:** The following cables can be used to attach SCSI devices to the integrated SCSI controller on the system board:
 - An Ultra320 twisted ribbon cable connects the internal Ultra320 SCSI hard disk drive to the SCSI connector on the system board. This cable has four additional connectors for attaching more internal SCSI devices.
 - A round SCSI cable connects external SCSI devices to the integrated SCSI controller on the system board. For more information about connecting SCSI devices, see the SCSI documentation.

Installing memory modules

The following notes describe the types of dual inline memory modules (DIMMs) that the computer supports and other information that you must consider when installing DIMMs:

- The computer comes with either two 256 MB or two 512 MB memory DIMMs installed in DIMM 1 and DIMM 2 memory connectors. The second pair of DIMMs must be installed in DIMM 3 and DIMM 4 memory connectors and the third pair in DIMM 5 and DIMM 6 memory connectors.
- DIMMs must be installed in matched pairs. The DIMMs in each pair must be the same size, speed, type, and technology as each other but do not have to match the other pairs. You can mix compatible DIMMs from various manufacturers.
- Install only 1.8 V, 240-pin, double-data-rate 2 (DDR2), PC2-3200, registered, synchronous dynamic random-access memory (SDRAM) with error correcting code (ECC), dual inline memory modules (DIMMs). These DIMMs must be compatible with the latest PC2-3200 SDRAM buffered DIMM specification. For a list of supported options for your computer, go to <http://www.ibm.com/pc/>; then, select your country and navigate to the list of options for your computer.
- The DIMM-installation sequence is based on single-rank, double-rank, and mixing single-rank and double-rank memory DIMMs. *Single-rank* DIMMs are 256 MB, 512 MB, and 1 GB memory modules. *Double-rank* DIMMs are 2 GB memory modules. The following table lists the DIMM-installation sequence for the computer maximum memory capacity using mixed single-rank and double-rank DIMMs.

Notes:

1. Do not install four, 2 GB double-rank DIMMs for the computer maximum capacity (8 GB) configuration, the computer does not support it.
2. You can install pairs of 256 MB, 512 MB, 1 GB, and 2 GB DIMMs in the computer, but for the computer maximum capacity, you must use the DIMM-sequence in the table below.
3. You can install any combination of DIMM pairs in the computer, however, you can install only two, 2 GB double-rank DIMMs in the computer and they must go in DIMM connectors 1 and 2. Do not install 2 GB double-rank DIMMs in any connectors other than DIMM connectors 1 and 2.
4. If you order memory DIMMs from IBM, the variable *2R* in the description indicates that the DIMM is a double-rank 2 GB DIMM.

Table 2. Maximum memory capacity (8 GB) and installation sequence mixing single-rank and double-rank DIMMs

DIMM pair	DIMM connectors	DIMM size	Rank
First pair	1, 2	2 GB	Double-rank
Second pair	3, 4	1 GB	Single-rank
Third pair	5, 6	1 GB	Single-rank

- The system board contains six DIMM connectors and supports two-way memory interleaving when the DIMMs are installed in pairs and functioning properly. If one DIMM in the pair fails, the computer runs in single-channel mode (non-interleaving). A failed DIMM must be replaced as soon as possible; otherwise, the computer will not start (boot).
- The DIMM options that are available for the computer are 256 MB, 512 MB, 1 GB, and 2 GB memory modules. The computer supports a minimum of 512 MB and a maximum of 8 MB (when using 2 GB double-rank DIMMs) of system memory.

Important: Although the computer supports a maximum of 8 GB of system memory, the Microsoft Windows operating systems recognize and support a maximum of 4 GB of system memory.

- The memory controller in the computer provides Chipkill memory protection if the DIMMs are 1 GB or larger, or if the computer is populated with 512 MB x4 DIMMs. Chipkill memory protection is a technology that protects the computer from a single chip failure on a DIMM.
- The amount of usable memory is reduced depending on the system configuration. A certain amount of memory must be reserved for system resources. The BIOS displays the total amount of installed memory and the amount of configured memory.

Complete the following steps to install DIMMs:

1. Read the safety information beginning on page 127 and “Handling static-sensitive devices” on page 23
2. Turn off the computer and all attached devices (see “Turning off the computer” on page 9); then, disconnect all power cords and external cables.
3. Remove the side cover (see “Removing the side cover” on page 25).
4. Locate the DIMM connectors on the system board. Determine the connectors into which you will install the DIMMs. See Table 2 on page 41 for additional information on DIMM-installation sequences.

Table 3. DIMM installation sequence

DIMM pair	DIMM connectors
First pair	1, 2
Second pair	3, 4
Third pair	5, 6

5. Gently open the retaining clip, if necessary, remove any existing DIMM.
6. Touch the static-protective package containing the DIMM to any unpainted metal surface on the computer. Then, remove the new DIMM from the package.
7. Gently open the retaining clip on each end of the DIMM slot. Turn the DIMM so that the pins align correctly with the connector.

8. Insert the DIMM into the connector. Firmly press the DIMM straight down into the connector by applying pressure on both ends of the DIMM simultaneously. The retaining clips snap into the locked position when the DIMM is firmly seated in the connector. If there is a gap between the DIMM and the retaining clips, the DIMM has not been correctly installed. Open the retaining clips, remove the DIMM, and then reinsert it.

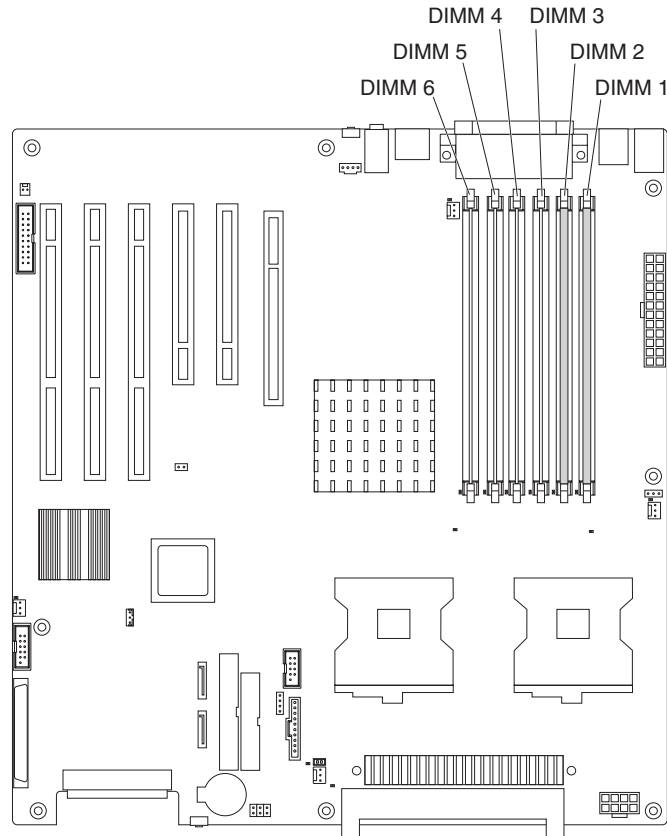

9. If you have other options to install or remove, do so now. Otherwise, replace the side cover (see “Replacing the side cover” on page 51).
10. Reconnect the external cables and power cords. Turn on the attached devices, and turn on the computer.

Installing a second microprocessor

Your computer comes with one microprocessor installed on the system board. Your computer supports up to two microprocessors. With two microprocessors, your computer can operate as a symmetric multiprocessing (SMP) computer. With SMP, certain operating systems and application programs can distribute the processing load among the microprocessors.

Note: When installing microprocessor options, lay the computer on its side.

The following notes describe information that you must consider when installing an additional microprocessor in your computer:

- Read the documentation that comes with the microprocessor to determine whether you need to update the computer basic input/output system (BIOS) code. The most current level of BIOS code for the computer is available from <http://www.ibm.com/support>.
- (Optional) Obtain an SMP-capable operating system. For a list of supported operating systems, go to <http://www.ibm.com/pc/us/compat/>.
- To ensure proper computer operation, use microprocessors that have the same cache size and type, and the same clock speed. Microprocessor internal and external clock frequencies must be identical. You can use the Configuration/Setup Utility program in your computer to determine the specific type of microprocessor on your system board.

Important: The first microprocessor must always be installed in the Microprocessor 1 socket.

- The microprocessor speeds are automatically set for this computer; therefore, you do not need to set any microprocessor frequency-selection jumpers or switches.
- Terminator cards are not required for empty microprocessor sockets. However, for airflow, an empty microprocessor socket must contain a microprocessor baffle.
- If you need to replace a microprocessor, see “Microprocessor and heat sink” on page 60.
- For additional illustrations of the system-board components, see “System board option connectors” on page 71.
- To order additional microprocessor options, contact your IBM marketing representative or authorized reseller.
- For a list of supported microprocessor options for your computer, go to <http://www.ibm.com/pc/>; then, select your country and navigate to the list of options for your computer

The Microsoft Windows XP operating system that comes preinstalled on your computer automatically configures itself when an additional microprocessor is installed. Other operating systems might have to be manually configured to support an additional microprocessor. See the *User's Guide* on the IBM *IntelliStation Documentation* CD for instructions.

Complete the following steps to install an additional microprocessor:

1. Read the safety information beginning on page 127 and the guidelines in “Handling static-sensitive devices” on page 23.
2. Turn off the computer and all attached devices. (See “Turning off the computer” on page 9.)

3. Disconnect all external cables and power cords.
4. Remove the side cover (see “Removing the side cover” on page 25).
5. Disconnect the fan connector for the fan that is attached to the back of the drive cage from the system board.
6. Press in on the drive-cage release lever and rotate the drive cage all the way out of the computer until it locks into place over the drive-cage retention tab. The open ends of the drive slots and installed drives will face you.

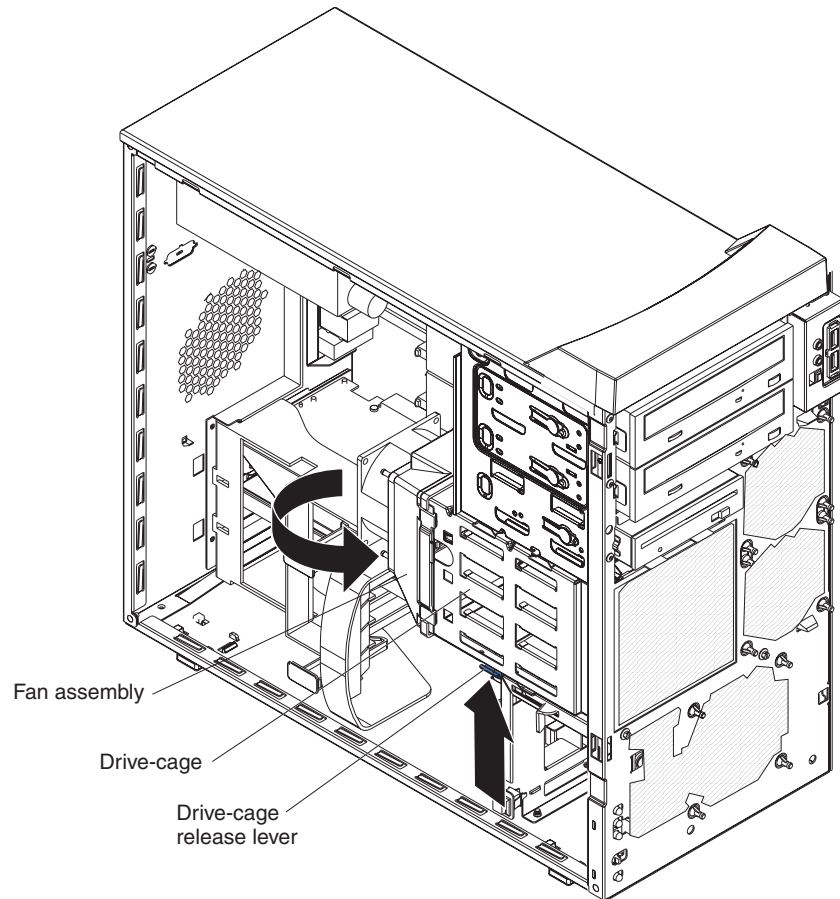

7. Move or disconnect any cables that might be in the way so you can remove the microprocessors' air baffle.
8. Remove the air baffle for the microprocessors by pulling it outward and lifting it out of the computer.

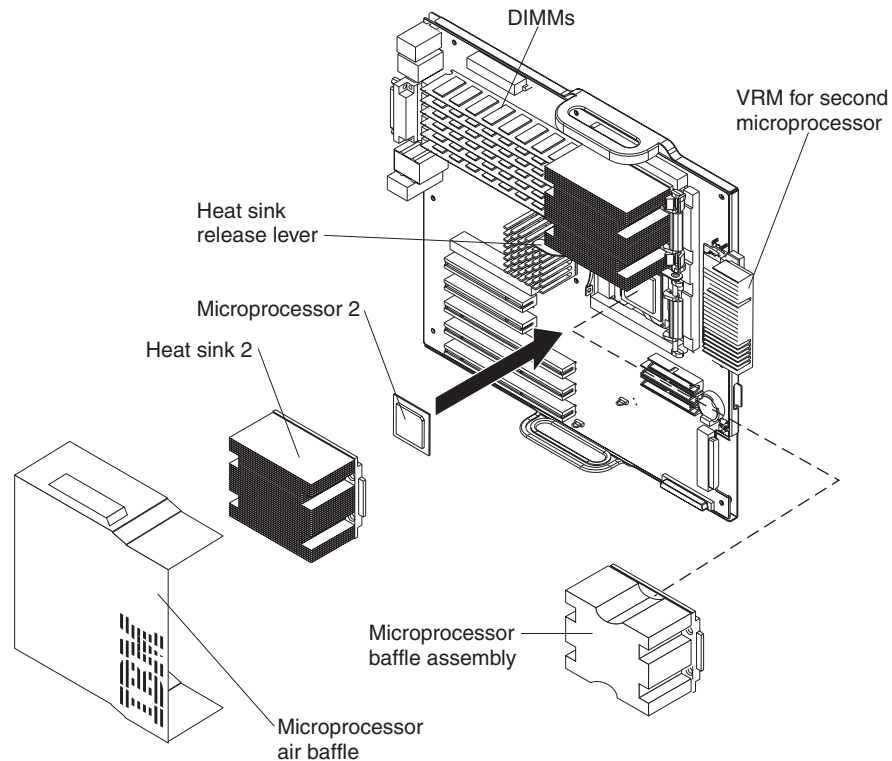

9. Locate the second microprocessor socket (Microprocessor 2) on the system board.
10. Remove the microprocessor baffle assembly from the second microprocessor socket.
 - a. Press down on the blue touch point of the heat-sink release lever and rotate the lever all the way out until it stops.
 - b. Grasp the front of the microprocessor baffle assembly and tilt it up while pulling the rear flange out of the heat-sink retention module; then, lift it out of the computer and store it in a safe place.
11. If the second microprocessor socket is covered with protective film or a label, peel and remove the film or label.
12. Install the microprocessor:
 - a. Touch the static-protective package containing the new microprocessor to any *unpainted* metal surface on the computer; then, remove the microprocessor from the package.
 - b. Rotate the locking lever on the microprocessor socket from its closed and locked position until it stops or clicks in the fully open position (approximately 135°).

Attention: You must ensure that the locking lever on the microprocessor socket is in the fully open position before you insert the microprocessor in the socket. Failure to do so might result in permanent damage to the microprocessor, microprocessor socket, and system board.
 - c. Position the microprocessor over the microprocessor socket. Align the triangle on the corner of the microprocessor with the triangle on the corner of the socket and carefully press the microprocessor into the socket.

Attention:

- 1) Do not use excessive force when pressing the microprocessor into the socket.
- 2) Make sure that the microprocessor is oriented and aligned correctly with pin number 1 in the socket before you try to close the lever. The following illustration shows the alignment marks for both microprocessors and sockets.

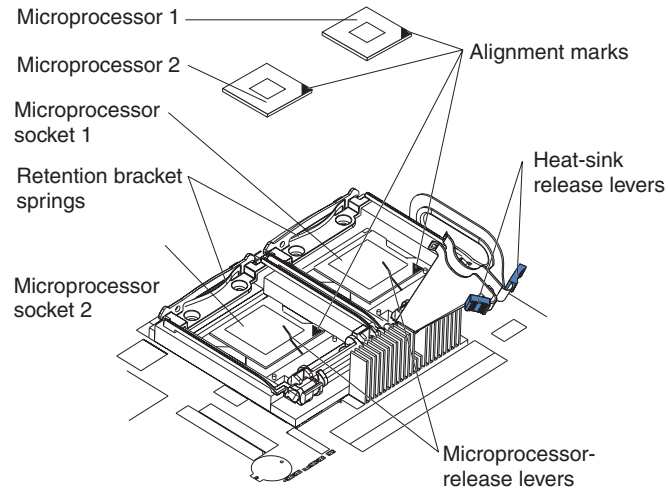

- d. Carefully close the lever to secure the microprocessor in the socket.
13. Install the heat sink on the microprocessor.

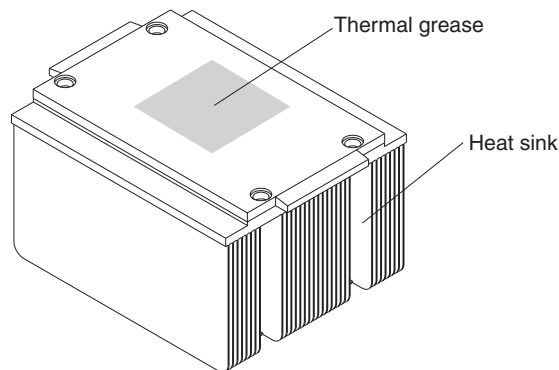

- a. Remove the plastic cover from the bottom of the heat sink.
Attention: Do not set the heat sink down after you remove the plastic cover and do not touch the thermal grease on the bottom of the heat sink. Touching the thermal grease will contaminate it. If the thermal grease on the heat sink becomes contaminated, replace the heat sink.
- b. Align the heat sink (grease side down) over the microprocessor and retention bracket.
- c. Slide the rear flange of the heat sink rearward into the opening beneath the retention-bracket spring.
- d. Press down firmly on the front of the heat sink until it is seated correctly.
- e. Secure the heat sink to the microprocessor by rotating the heat-sink release lever to the closed position and hooking it underneath the tab on the microprocessor socket.
- f. Insert the voltage regulator module (VRM) into the VRM connector.

14. Replace the air baffle for the microprocessors. Slant the front of the air baffle for the microprocessors downward at an angle while moving it forward; then, rotate the rear of the air baffle down until it snaps into place (it will become stationary).
15. Rotate the drive cage back into the computer and reconnect the fan connector on the fan assembly on the drive cage to the system board.
16. If you have other options to install or remove, do so now. Otherwise, replace the side cover (see “Replacing the side cover” on page 51).
17. Reconnect the external cables and power cords. Turn on the attached devices, and turn on the computer.

Installing an external SCSI cable

To install an external SCSI connector on the rear of the computer, install an external SCSI interface option. For a list of supported external SCSI interface options for your computer, go to <http://www.ibm.com/pc/>.

The external SCSI interface option contains a SCSI cable with a connector at one end and on the other end another connector or an expansion-slot cover with an embedded connector. Complete the following steps to install and route the SCSI cable in the computer:

1. Turn off the computer and all peripheral devices. Disconnect all power cords; then, disconnect all external signal cables from the computer.
2. Remove the side cover (see “Removing the side cover” on page 25).
3. Open the front adapter-retention bracket and remove the rear adapter-retention bracket from the PCI-X slots (see “Installing an adapter” on page 26 for instructions). You might also have to remove longer adapters for access to the SCSI connectors on the system board.
4. Connect the SCSI signal cable to the connector for SCSI channel A on the system board. See “System board internal connectors” on page 72 for the location of the SCSI channel A connector.
5. Route the SCSI cable between the chassis and PCI-X slot 5 to the back of the computer. Make sure that the cable does not block the flow of air to the microprocessors or hard disk drives.
6. Attach the external connector to the rear of the computer.
 - If the external end of the SCSI cable has a standard SCSI connector, complete the following steps:
 - a. Remove the SCSI-connector knockout from the rear of the computer.
 - b. Insert the external SCSI connector on the SCSI cable into the knockout opening and secure it with the attached screws.
 - If the external end of the SCSI cable has an expansion-slot cover with an embedded connector, complete the following steps:
 - a. Remove an expansion-slot cover from an available PCI-X slot.
 - b. Insert the expansion-slot cover with embedded connector into the slot opening.

7. Replace any adapters that you removed in step 3. Close the front adapter-retention bracket and replace the rear adapter-retention bracket.
8. Replace the cover (see “Replacing the side cover” on page 51).
9. Reconnect the external cables and power cords. Turn on the attached devices, and turn on the computer.
10. Use the SCSISelect program to configure SCSI channel A.

Installing a security rope clip

To help prevent hardware theft, you can add a security rope clip and cable to your computer. After you add the security cable, make sure that it does not interfere with other cables that are connected to the computer.

Before you begin, obtain the following items:

- A flat-blade screwdriver
- An adjustable wrench
- A 19-mm (0.75-in.) rope clip or wire rope (similar to National Manufacturing number 3230, stock number 176-735)
- Threaded nuts that fit the rope clip
- A security cable
- A lock, such as a combination lock or padlock

Complete the following steps to install a rope clip:

1. Turn off the computer and all attached devices.
2. Disconnect all external cables and power cords; then, remove the side cover. See “Removing the side cover” on page 25
3. Use a screwdriver to remove the two metal knockouts.
4. Insert the rope clip through the rear panel; then, attach and tighten the nuts.

5. Thread the cable through the rope clip and around an object that is not part of or permanently secured to the building structure or foundation and from which the cable cannot be removed. Fasten the cable ends together with a lock. After you add the security cable, make sure that it does not interfere with other cables that are connected to the computer.

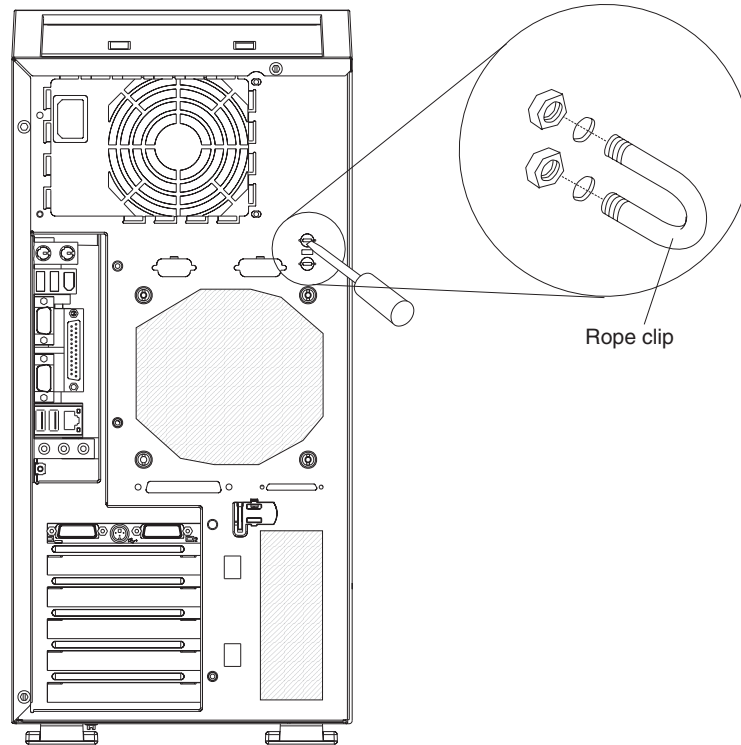

6. If you have other options to install or remove, do so now; otherwise, replace the side cover (see “Replacing the side cover” on page 51).
7. Reconnect the external cables and power cords. Turn on the attached devices, and turn on the computer.

Replacing the bezel

Complete the following steps to replace the bezel:

1. Insert the tabs on the side of the bezel into the matching holes on the computer chassis.
2. Push the bezel toward the computer until the tabs and bezel clips snap into place.

Replacing the side cover

Complete the following steps to replace the side cover.

1. Before installing the cover, check that all cables, adapters, and other components are installed and seated correctly and that you have cleared all work tools from inside the computer.
2. Install the side cover by placing it into position on the computer. Make sure that the lip on the bottom of the cover rests inside the ledge on the bottom of the chassis before rotating the cover toward the computer. Press down and forward on the cover until it locks.

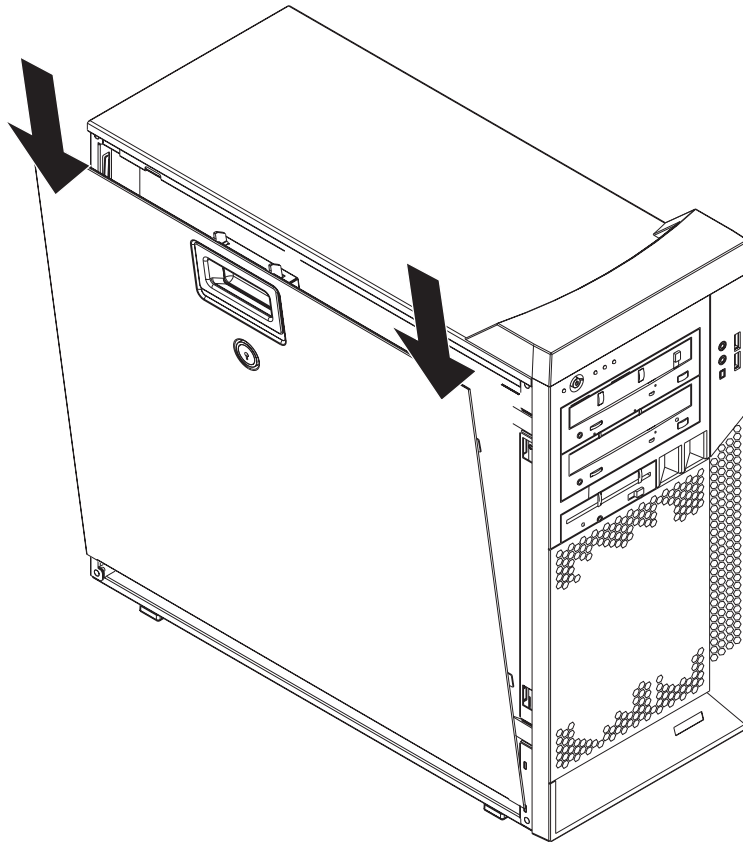

3. Reconnect the external cables and power cords to the computer.
4. Turn on the attached devices; then, turn on the computer.

Connecting external options

You can connect a number of optional external devices to the connectors on the rear and front of the computer.

Complete the following steps to connect an external device:

1. Read the safety information beginning on page 127, the guidelines in “Handling static-sensitive devices” on page 23, and the documentation that comes with your options.
2. Turn off the computer and all attached devices (see “Turning off the computer” on page 9).
3. Follow the instructions that come with the option to prepare it for installation and to connect it to the computer.

If you are attaching a SCSI device, see “Ultra320 SCSI connector” on page 56 for SCSI ID and cabling information.

Input/output connectors

Connect optional external devices to the connectors on the front and rear of the computer.

Your computer has the following input/output (I/O) connectors:

- One audio line in
- Two audio line out
- Two audio microphone
- One Ethernet
- Two IEEE 1394A (FireWire)
- One keyboard
- One mouse
- One parallel
- Two serial
- Six Universal Serial Bus (USB) 2.0
- One video

The following illustration shows the locations of the connectors on the rear of the computer. See “Controls, LEDs, and connectors” on page 6 for the locations of the connectors on the front of the computer.

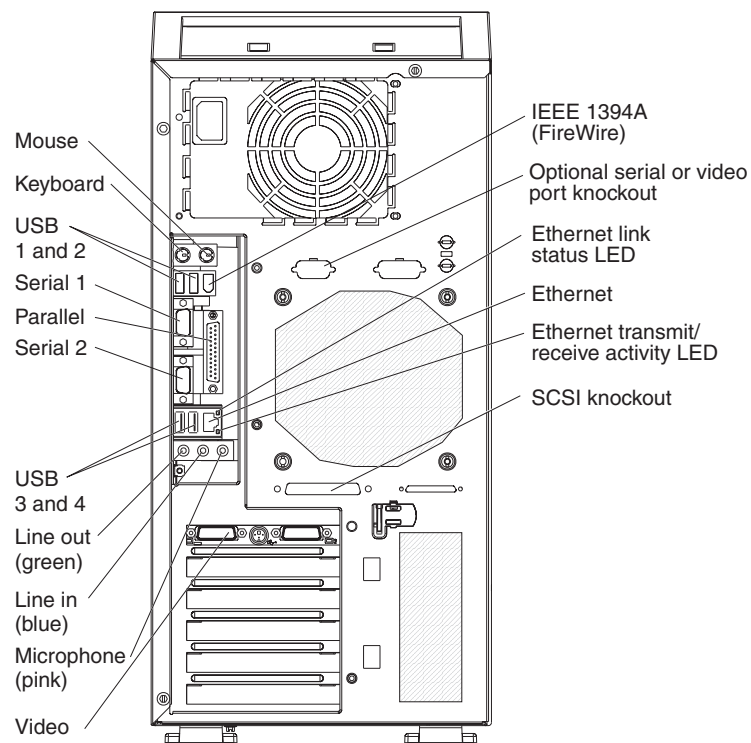

The following sections describe these connectors.

Audio connectors

Use the audio connectors to connect external audio equipment to the computer. The following illustration shows the audio connectors.

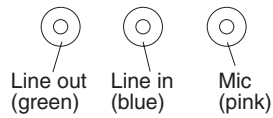

Line in

There is one line-in connector on the rear of the computer. The computer receives audio signals through this connector from an external audio device.

Line out

There are two line-out connectors, one on the front and one on the rear of the computer. The computer sends audio signals through this connector to powered speakers with built-in amplifiers, headphones, a multimedia keyboard, or the audio line-in connector on a stereo system. The internal speaker in the computer is disabled when a device is attached to this connector.

Mic

There are two microphone connectors, one on the front and one on the rear of the computer. Connect a microphone to this connector to record sounds onto the hard disk or to use speech-recognition software.

Auxiliary-device (pointing-device) connector

There is one auxiliary-device connector on the rear of the computer. Use this connector to connect a mouse or other pointing device. The following illustration shows an auxiliary-device connector.

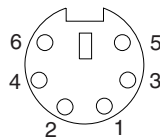

Ethernet (RJ-45) connector

There is one Ethernet connector on the rear of the computer. Use this connector to connect the computer to a 10-Mbps, 100-Mbps, or 1000-Mbps network. The following illustration shows an Ethernet connector.

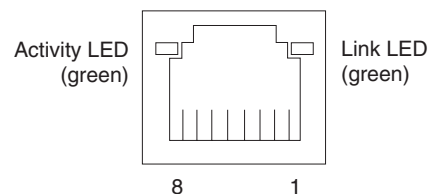

Connect a Category 3, 4, or 5 unshielded twisted-pair (UTP) cable to this connector. The 100BASE-TX and 1000BASE-T Fast Ethernet standards require Category 5 or higher cabling.

The Ethernet connector has one LED that indicates Ethernet-link status. When this LED is lit, it indicates that there is an active connection on the Ethernet port. Activity between the computer and the network is indicated by the Ethernet transmit/receive activity LEDs on the front and rear of the computer (see “Controls, LEDs, and connectors” on page 6).

IEEE 1394A (FireWire) connector

There is one 4-pin IEEE 1394A (FireWire) connector on the front of the computer and one 6-pin IEEE 1394A (FireWire) connector on the rear of the computer. Use these connectors to connect IEEE 1394A (FireWire) devices. The following illustrations show the IEEE 1394A (FireWire) connectors.

4-pin IEEE 1394A (FireWire) connector (front)

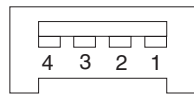

6-pin IEEE 1394A (FireWire) connector (rear)

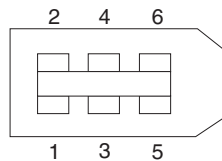

Keyboard connector

There is one keyboard connector on the rear of the computer. Use this connector to connect a PS/2 (non-USB) keyboard. The following illustration shows a keyboard connector.

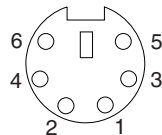

If you attach a keyboard to this connector, USB ports and devices are disabled during the power-on self-test (POST).

Parallel connector

There is one parallel connector on the rear of the computer. Use this connector to connect a parallel device. The following illustration shows a parallel connector.

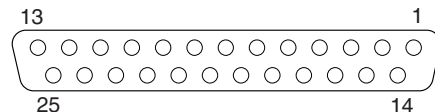

The parallel connector supports three standard Institute of Electrical and Electronics Engineers (IEEE) 1284 modes of operation: standard parallel port (SPP), enhanced parallel port (EPP), and extended capability port (ECP). If you configure the parallel port to operate in bidirectional mode, it supports the ECP and EPP modes. When the parallel connector is configured as bidirectional, use an IEEE 1284-compliant

cable that does not exceed 3 meters (9.8 ft). Use the **Devices and I/O Ports** options in the IBM Configuration/Setup Utility program to configure the parallel connector as bidirectional.

Serial connectors

There are two serial connectors on the rear of the computer. Use these connectors to connect serial devices. The following illustration shows a serial connector.

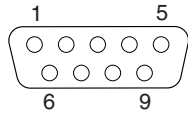

Ultra320 SCSI connector

Your computer has an integrated SCSI controller. This dual-channel controller supports two independent, Ultra320 SCSI channels that support up to 15 SCSI devices each. The SCSI connectors for the channels are on the system board. The controller has the following features:

- Double-transition clocking to achieve up to 320 MBps (megabytes per second) data-transfer rates
- Domain name validation to negotiate compatible data-transfer speeds with each device
- Cyclic-redundancy checking (CRC) to improve data reliability
- An active terminator for SCSI bus termination

The following illustration shows a SCSI connector.

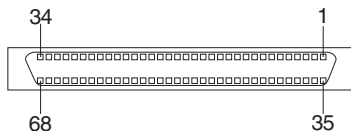

SCSI cabling requirements

You can install four internal SCSI devices using the SCSI signal cable that comes with some computer models. If you plan to attach external SCSI devices, you can order an additional SCSI cable, remove the SCSI knockout from the rear of the computer, and connect the new cable from the SCSI channel A connector on the system board to this opening. To select and order the correct cables for use with external devices, contact your IBM marketing representative or authorized reseller. See “System board internal connectors” on page 72 for the locations of the SCSI connectors.

If you want to attach external SCSI devices to the computer without using the internal SCSI channel B, you must install an optional SCSI adapter.

Setting SCSI IDs

Each SCSI device that is connected to a SCSI controller must have a unique SCSI ID. This ID enables the SCSI controller to identify the device and ensure that different devices on the same SCSI channel do not attempt to transfer data simultaneously. SCSI devices that are connected to different SCSI channels can have duplicate SCSI IDs. See the information that comes with the device for instructions for setting its SCSI ID.

Universal Serial Bus connectors

There are six Universal Serial Bus (USB) 2.0 connectors, two on the front and four on the rear of the computer. Use the USB connectors to connect optional telephony and multimedia devices. USB 2.0 technology transfers data at up to 480 Mbps (Mb per second) with a maximum of 127 external devices and a maximum signal distance of 5 meters (16 ft) per segment (if the device that is attached to the computer is a USB 2.0 device). If multiple USB devices are attached to the computer, the USB hub must be USB 2.0; otherwise, all USB 2.0 devices will transfer data at 12 Mbps. Using Plug and Play technology, USB devices are configured automatically. The following illustration shows a USB connector.

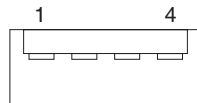

Use a 4-pin USB cable to connect an external devices to a USB connector.

If you connect a PS/2 (non-USB) keyboard to the keyboard connector, USB ports and devices are disabled during power-on self-test (POST).

If you connect a USB keyboard that has a mouse port, the keyboard emulates a mouse, and you cannot disable the mouse settings in the Configuration/Setup Utility program.

Video connector

The PCI Express x16 adapter, which is in PCI slot 1 on the system board, provides the video connector. This connector is on the rear of the computer. Use the video connector to connect a monitor or other display device. The following illustrations show examples of different video connectors.

Analog video connector

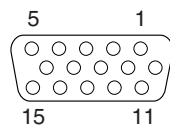

Digital (DVI-I) video connector

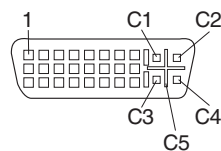

Dual monitor system-59 (DMS-59) video connector

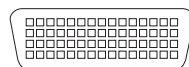

Some models come with a digital video interface (DVI) connector for connecting a digital monitor. If you have problems viewing information with a second monitor, refer to the User's Guide.

Models with the NVIDIA Quadro FX 1300 or NVIDIA Quadro FX 3400 video adapter come with a DVI-I to VGA style analog converter for each DVI-I connector.

Attention: To get the best performance from the NVIDIA Quadro FX 3400 video adapter, you must connect the video adapter to the computer power supply. Otherwise, the video adapter will be operating with very limited power, resulting in a decrease in performance for some applications. Use the PCI Express x16 external power drop to connect the video adapter to the computer power supply. The following illustration shows the location of the video adapter power connector.

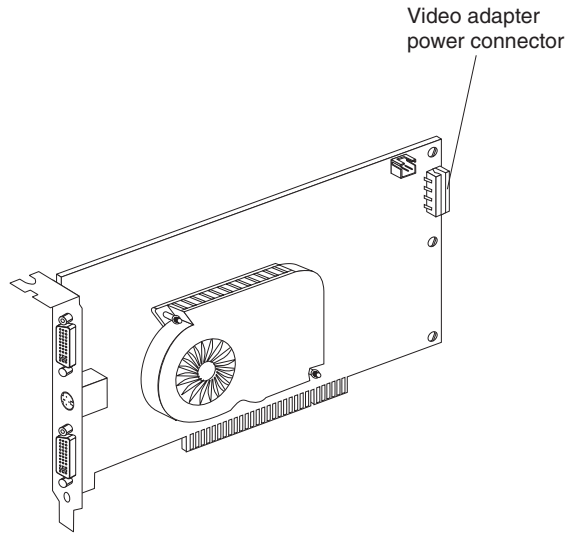

Models with the NVIDIA Quadro NVS 280 video adapter come with a dual monitor system-59 (DMS-59) to dual-analog monitor pigtail cable. If you want to set up two digital monitors, you will have to purchase a separate dual-digital monitor cable.

Chapter 5. Field replaceable units

Microprocessor and heat sink	60
CD-ROM drive	61
Non-hot swap power supply	62
Rear-adapter retention bracket	63
I/O card retainer	64
Front (microprocessor) fan	65
Hard drive fan	66
Power/LED switch assembly	68
Card/bracket assembly	69
Speaker	70
System board	71
System board option connectors	71
System board internal connectors	72
System board external connectors	73
System board error LEDs	74
System board jumpers and switches	75
Removing the system board	76
Top/side cover	78
Bezel-release latch	79
Handle assembly	81

The following information describes procedures for removing and installing certain components inside the system. Only a qualified service technician is authorized to replace the components described in this section.

Important: The field replaceable unit (FRU) procedures are intended for trained servicers who are familiar with IBM IntelliStation Z Pro products. See the parts listing in “System replaceable units” on page 117 to determine if the component being replaced is a customer replaceable unit (CRU) or a FRU.

Note: Before servicing this system, read “Installation guidelines” on page 23 and Appendix B, “Safety information,” on page 127.

Microprocessor and heat sink

Before you begin:

- Read the “Installation guidelines” on page 23.
- Read Appendix B, “Safety information,” on page 127.
- Review the information in “System reliability considerations” on page 23.

To remove the microprocessor and heat sink, complete the following steps.

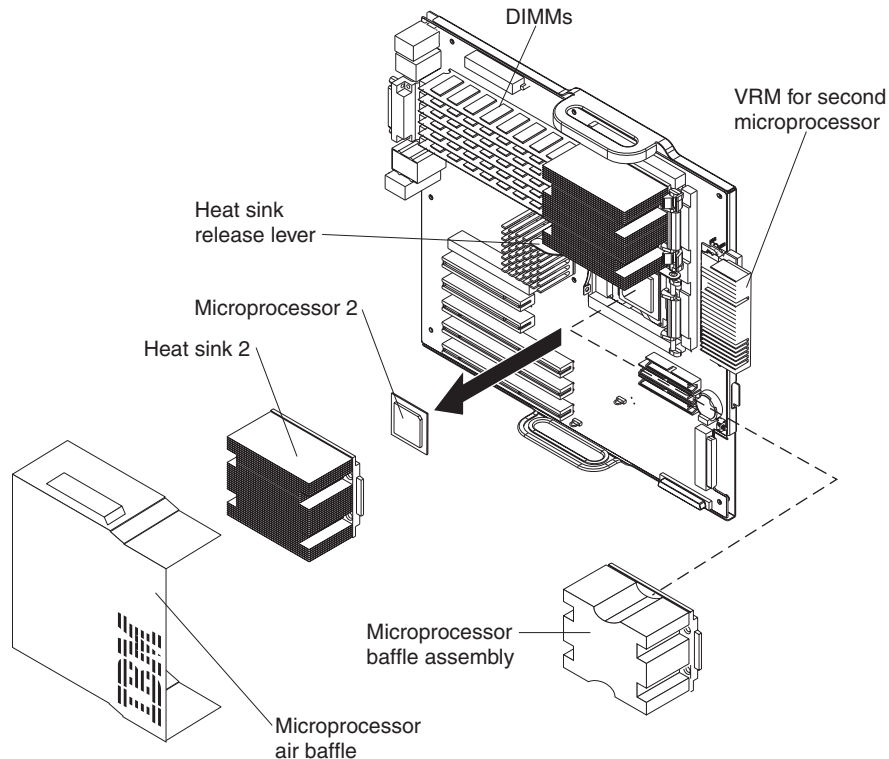

1. Turn off the computer and remove external cables.
2. Remove the side cover (see “Removing the side cover” on page 25).
3. Disconnect any cables that impede access to the microprocessor.
4. Remove the heat sink from the microprocessor:
 - a. Press the microprocessor-baffle release lever down, move it toward the other microprocessor, and lift it up to the open position.
 - b. Slide the heat-sink assembly toward the front of the computer and tip the rear flange out of the heat-sink socket.
 - c. Lift the heat sink up and out of the computer.

Note: It might be necessary to gently twist the heat sink to loosen it from the microprocessor.

Important: Be careful when handling the microprocessor and heat sink. If the thermal grease between the microprocessor and heat sink will be reused, do not contaminate it. If replacement thermal grease is provided with the replacement part, be sure to remove all traces of existing thermal grease from the remaining part before applying the new thermal grease.

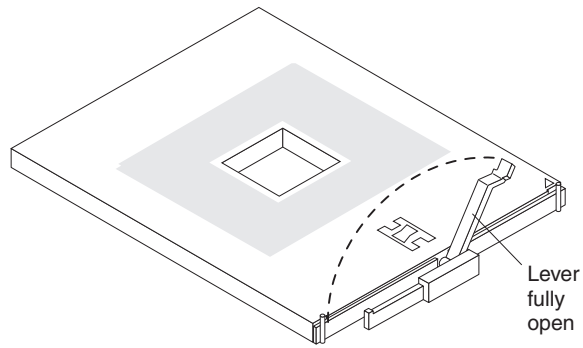

5. Rotate the microprocessor socket lever arm upward to its maximum vertical position (135°), and lift the microprocessor up and out of the computer.
6. To install a microprocessor, see “Installing a second microprocessor” on page 44, beginning with step 8 on page 45.

CD-ROM drive

Before you begin:

- Read Appendix B, “Safety information,” on page 127.
- Review the information in “System reliability considerations” on page 23.

To remove the CD-ROM drive, complete the following steps:

1. Turn off the computer, if it is on.
2. Disconnect the power cord from the power source and from the computer; then, disconnect all external cables.
3. Remove the side cover (see “Removing the side cover” on page 25).
4. Remove the front bezel (see “Removing the bezel” on page 26).
5. Disconnect the CD-ROM drive connector and power cables from the rear of the drive.
6. Press the touch point on the raised area of the drive cage for the CD-ROM drive and gently slide the drive out of the front of the computer.

For instructions for replacing the CD-ROM drive, see “Installing a drive in bay 2 or 3” on page 32.

Non-hot swap power supply

Before you begin:

- Read Appendix B, “Safety information,” on page 127.
- Review the information in “System reliability considerations” on page 23.

To remove the non-hot-swap power supply, complete the following steps:

1. Turn off the computer, if it is on.
2. Disconnect the power cord from the power source and from the computer; then, disconnect all external cables.
3. Remove the cover (see “Removing the side cover” on page 25).
4. Disconnect internal cables from the power supply to the system board and any other components to which it is attached, making a note of where they connect.

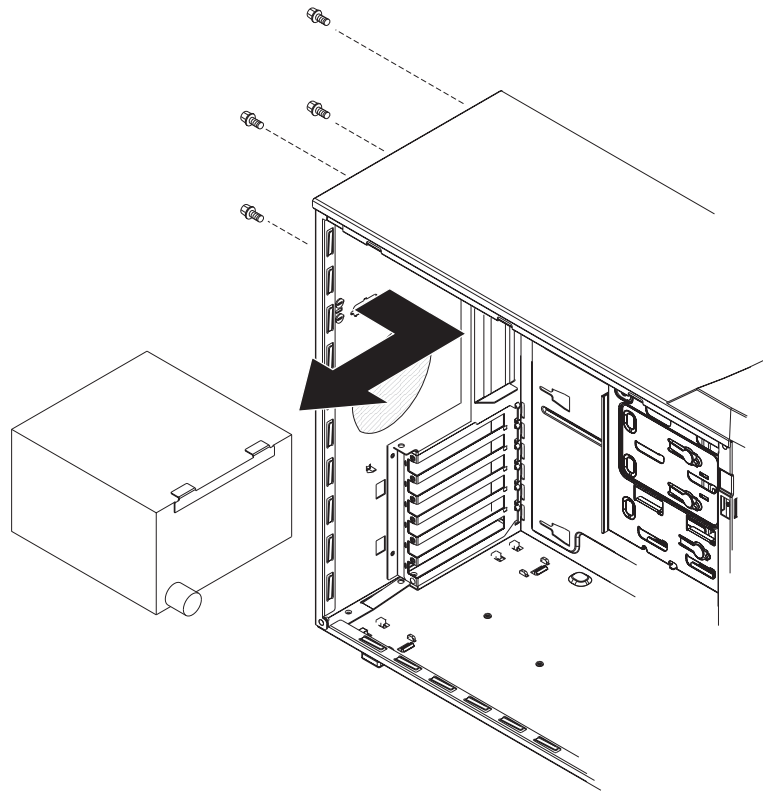

5. Remove the screws from the rear of the computer.
6. Gently move the power supply away from the chassis and lift it out of the computer.

To replace the non-hot-swap power supply, complete the following steps:

1. Align the tabs on the top of the power supply with the tab slots on the underside of the top rear of the chassis, and slide the power supply toward the rear of the chassis.
2. Secure the power supply to the rear of the chassis with the four screws.
3. Reconnect the power cables.

Rear-adapter retention bracket

Before you begin:

- Read Appendix B, “Safety information,” on page 127.
- Review the information in “System reliability considerations” on page 23.

To remove the rear-adapter retainer, complete the following steps:

1. Turn off the computer, if it is on.
2. Disconnect the power cord from the power source and from the computer; then, disconnect all external cables.
3. Remove the side cover (see “Removing the side cover” on page 25).
4. Remove all adapters (see “Installing an adapter” on page 26).
5. Grasp the rear adapter retainer, and gently slide the top and bottom tabs out of the notches.

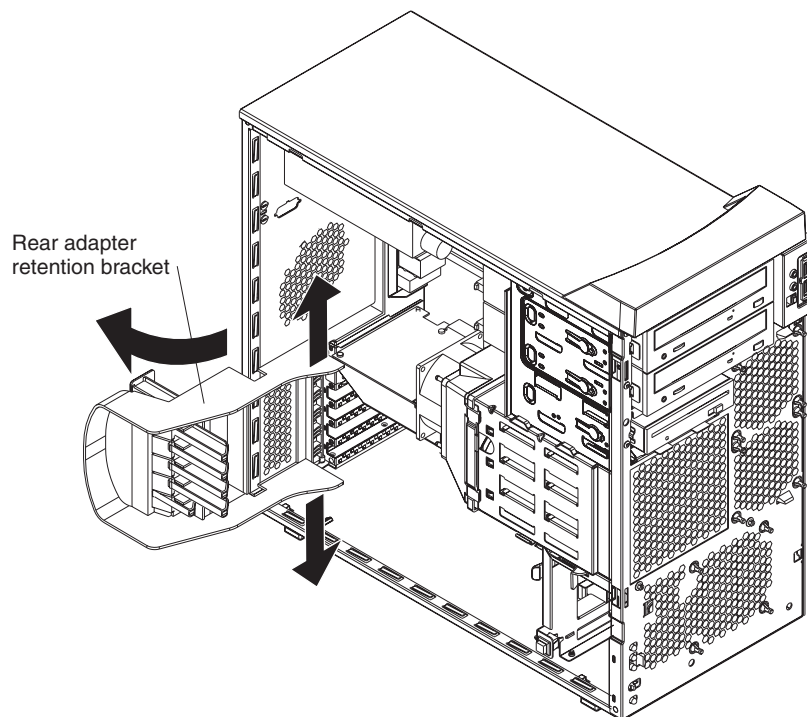

To replace the rear adapter retainer, reverse the steps.

I/O card retainer

Before you begin:

- Read Appendix B, “Safety information,” on page 127.
- Review the information in “System reliability considerations” on page 23.

To remove the I/O card retainer, complete the following steps:

1. Turn off the computer, if it is on.
2. Disconnect the power cord from the power source and from the computer; then, disconnect all external cables.
3. Remove the side cover (see “Removing the side cover” on page 25).
4. Remove all adapters (see “Installing an adapter” on page 26).

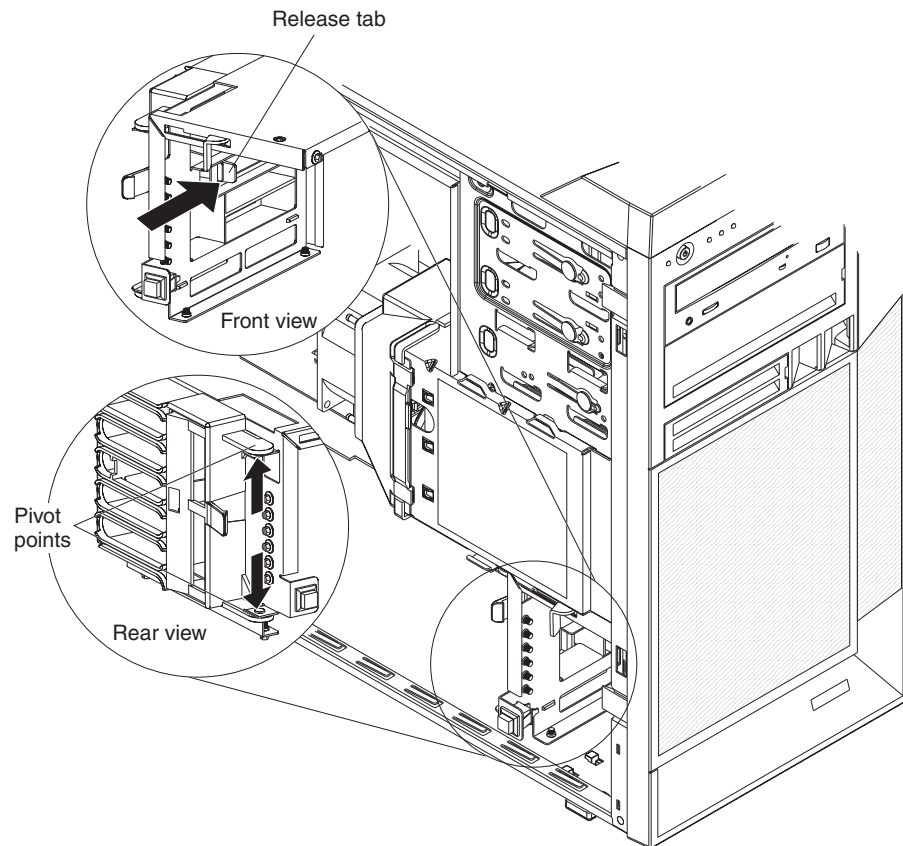

5. Squeeze the two release tabs on the card retainer.
6. Pull out on the two pivot points of the retainer and remove it from the computer.

To replace the I/O card retainer, reverse the steps.

Front (microprocessor) fan

Before you begin:

- Read Appendix B, “Safety information,” on page 127.
- Review the information in “System reliability considerations” on page 23.

To remove a front fan, complete the following steps:

1. Turn off the computer, if it is on.
2. Disconnect the power cord from the power source and from the computer; then, disconnect all external cables.
3. Remove the cover (see “Removing the side cover” on page 25).
4. Remove the front bezel (see “Removing the bezel” on page 26).
5. Pivot the drive cage out until it locks in position.

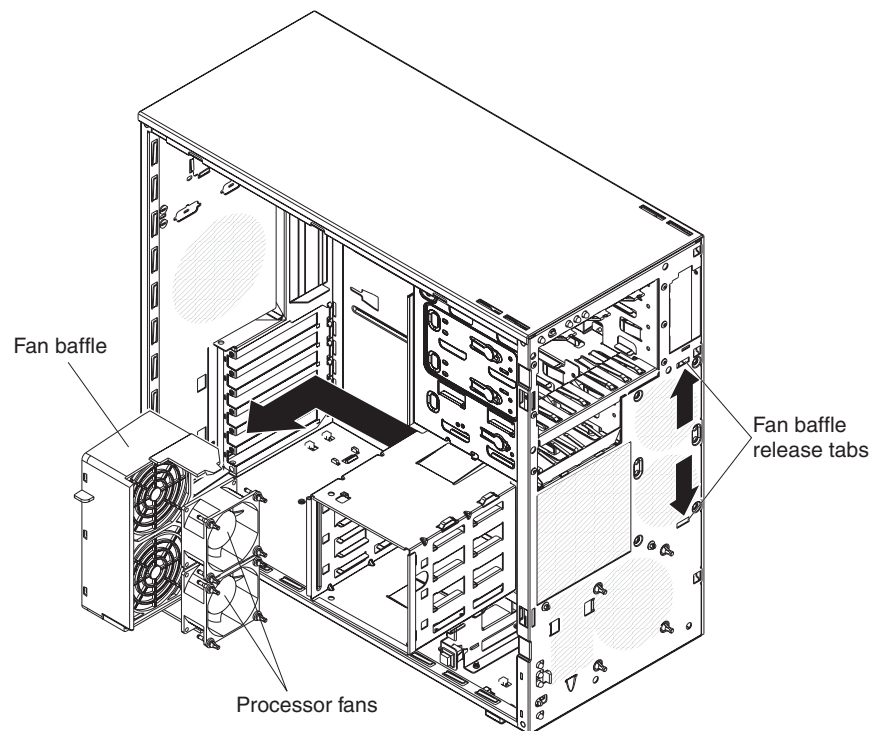

6. Squeeze the fan baffle release tabs so that they release from the notches in the chassis.

Note: It might be easier to perform this procedure if you remove adapters and remove the front I/O card retainer.

7. From inside the computer, grasp the fan baffle, slide it out, and remove it from the computer.
8. Note where the fan cable connects to the system board, and disconnect the cable from the system board.

Note: See the system service label or “System board internal connectors” on page 72 for system board connector locations.

9. Use side cutters to cut the four rubber extensions that secure the fan to the chassis.
10. Remove the fan from the computer, making sure that no rubber extensions are left loose in the computer.

To install the new front fan assembly, complete the following steps:

1. Place the fan in position against the chassis.
2. Guide the rubber extensions through the apertures.
3. Use needle-nosed pliers to pull the extensions through the apertures.
4. Connect the fan cable.
5. Slide the fan baffle into place and guide the tabs into the slots in the chassis until they lock in place.
6. If you removed the adapters and front I/O card retainer, replace the retainer and then the adapters.
7. Press the touch point on the side of the drive cage and lower it back into place in the computer.
8. Replace the bezel.
9. Replace the side cover.

Hard drive fan

Before you begin:

- Read Appendix B, “Safety information,” on page 127.
- Review the information in “System reliability considerations” on page 23.

To remove a rear fan, complete the following steps:

1. Turn off the computer, if it is on.
2. Disconnect the power cord from the power source and from the computer; then, disconnect all external cables.
3. Remove the side cover (see “Removing the side cover” on page 25).
4. Rotate the drive cage up until it locks in position.
5. Note where the fan cable connects to the system board, and disconnect the cable from the system board.

Note: See the system service label or “System board internal connectors” on page 72 for system board connector locations.

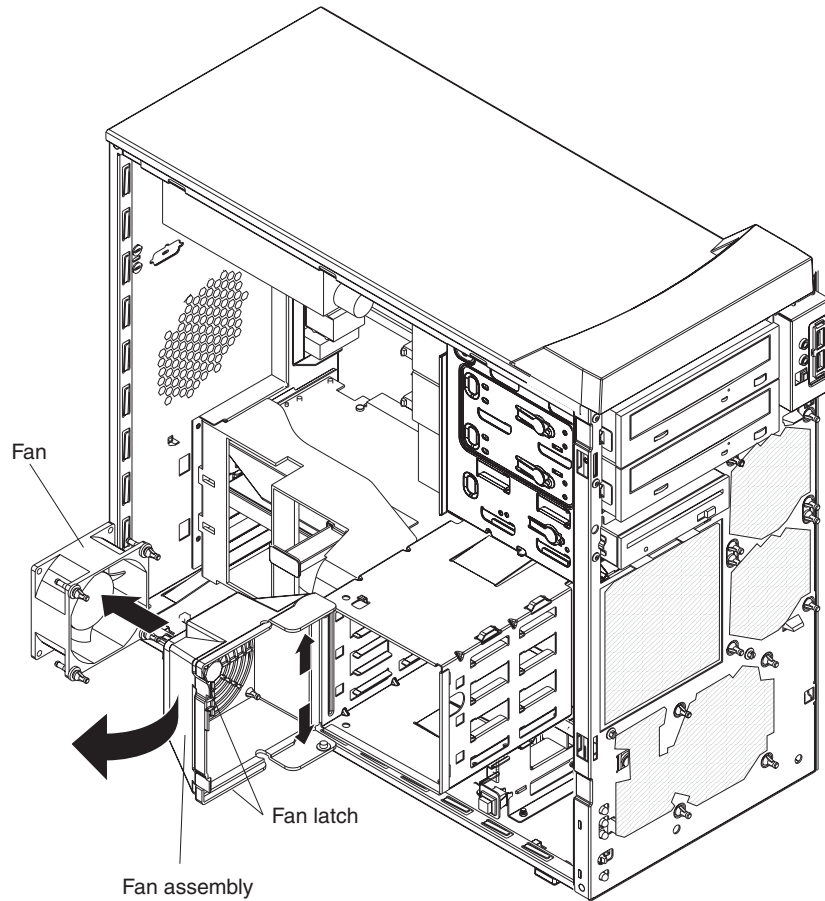

6. On the side of the drive cage facing the front of the computer, grasp the fan latch and pull it away from the drive cage, rotating it up.
7. Grasp the duct at the pivot points and pull them outward until they detach from the drive cage.
8. Set the assembly on a level work surface with the fan facing up.
9. Use side cutters to sever the four rubber extensions securing the fan to the duct and remove the fan.

To install the new rear fan assembly, reverse the previous steps, guiding the rubber extensions through the apertures and using needle-nosed pliers to pull them through.

Power/LED switch assembly

Before you begin:

- Read the “Installation guidelines” on page 23.
- Read Appendix B, “Safety information,” on page 127.
- Review the information in “System reliability considerations” on page 23.

To remove the power/LED switch assembly, complete the following steps:

1. Turn off the computer, if it is on.
2. Disconnect the power cord from the power source and from the computer; then, disconnect all external cables.
3. Remove the side cover (see “Removing the side cover” on page 25).
4. Remove the front bezel (see “Removing the bezel” on page 26).
5. Note where the power-switch and LED panel cable connects to the system board; then, carefully disconnect the cable from the system board.

Note: See the system service label or “System board internal connectors” on page 72 for system board connector locations.

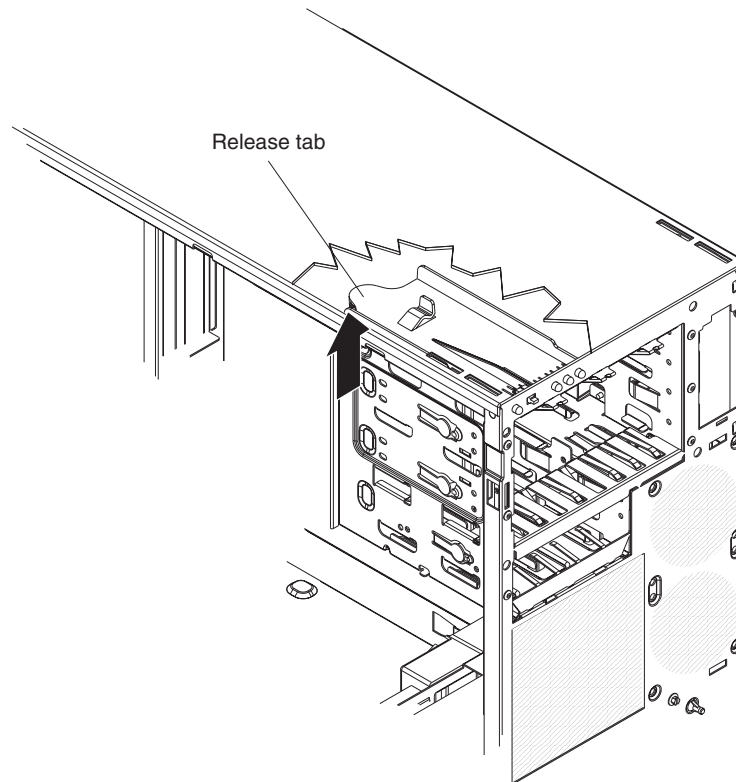

6. From inside the computer, press the release tab.
7. Pull the assembly toward the rear of the computer and remove it.

To replace the power/LED switch assembly, reverse the previous steps, making sure that the assembly clicks into place in the chassis.

Card/bracket assembly

Note:

- Read “Installation guidelines” on page 23.
- Read the safety notices at Appendix B, “Safety information,” on page 127.
- Read “Handling static-sensitive devices” on page 23.

Complete the following steps to remove the card/bracket connector assembly:

1. Turn off the computer and attached devices.
2. Disconnect the power cord from the power source and from the computer; then, disconnect all external cables.
3. Remove the side cover (see “Removing the side cover” on page 25).
4. Remove the front bezel (see “Removing the bezel” on page 26).

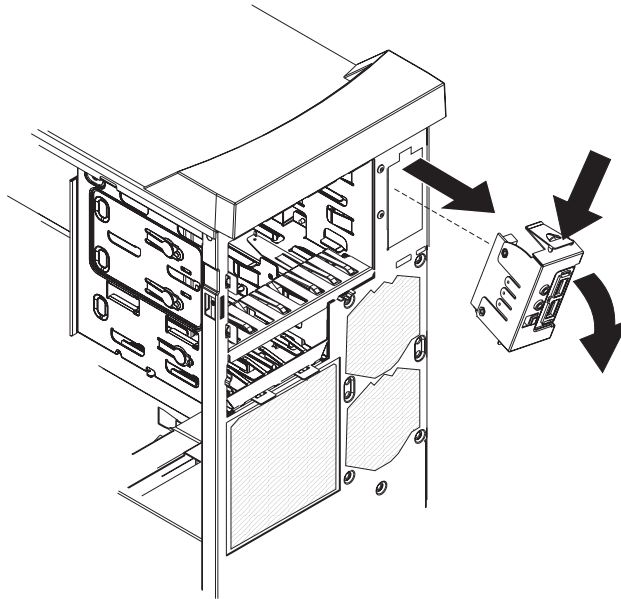

5. Press the latch on the top of the assembly; this side of the assembly will detach from the chassis.
6. Remove the tab on the bottom part of the assembly from the slot in the chassis.
7. Pull the assembly out slightly and detach the two cables from the back of the assembly.

To install the card/bracket connector assembly, reverse the previous steps, placing the bottom tab into the slot in the chassis and then pressing the top of the assembly into place.

Speaker

Note:

- Read “Installation guidelines” on page 23.
- Read the safety notices at Appendix B, “Safety information,” on page 127.
- Read “Handling static-sensitive devices” on page 23.

Complete the following steps to remove the speaker:

1. Turn off the computer and attached devices.
2. Disconnect the power cord from the power source and from the computer; then, disconnect all external cables.
3. Remove the side cover (see “Removing the side cover” on page 25).
4. Note where the speaker cable connects to the system board; then, carefully disconnect the cable from the system board.

Note: See the system service label or “System board internal connectors” on page 72 for system board connector locations.

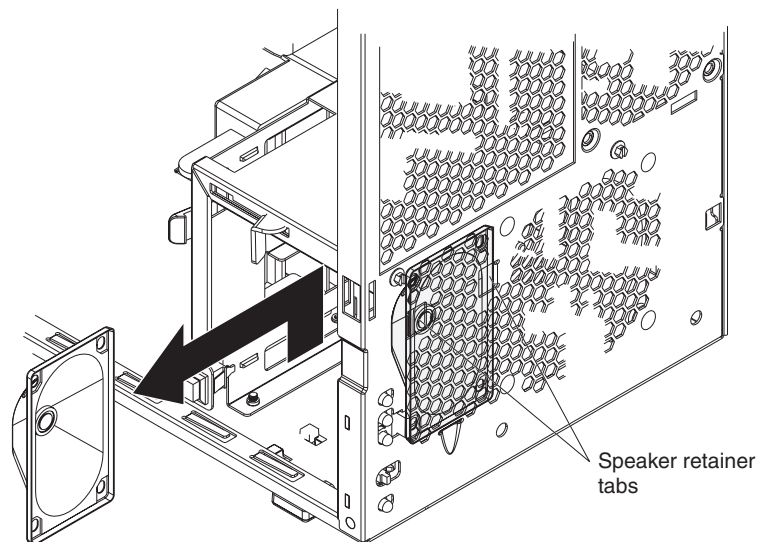

5. Press the speaker retainer tabs to detach them from the chassis.
6. Grasp the speaker and slide it up to clear the notches, and remove it.

To install the speaker, reverse the previous steps.

System board

This section contains service information for the system board.

System board option connectors

The following illustration shows the system board connectors for user-installable options.

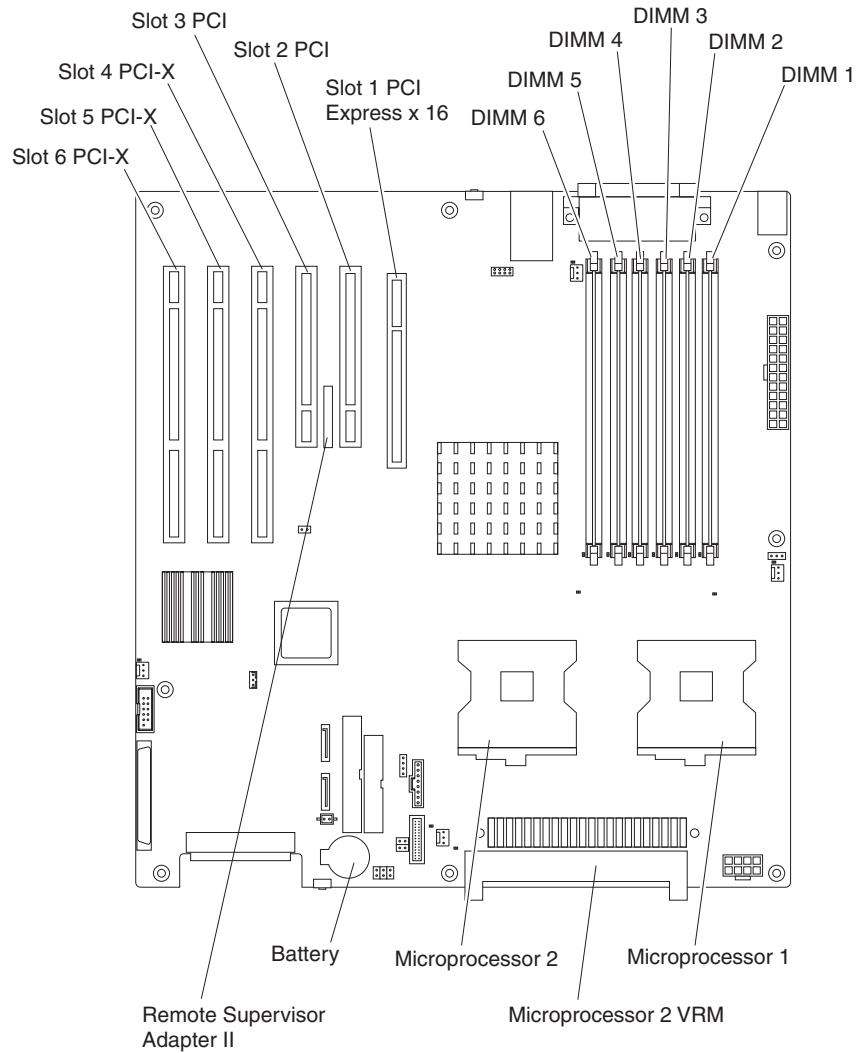

System board internal connectors

The following illustration shows the internal connectors on the system board.

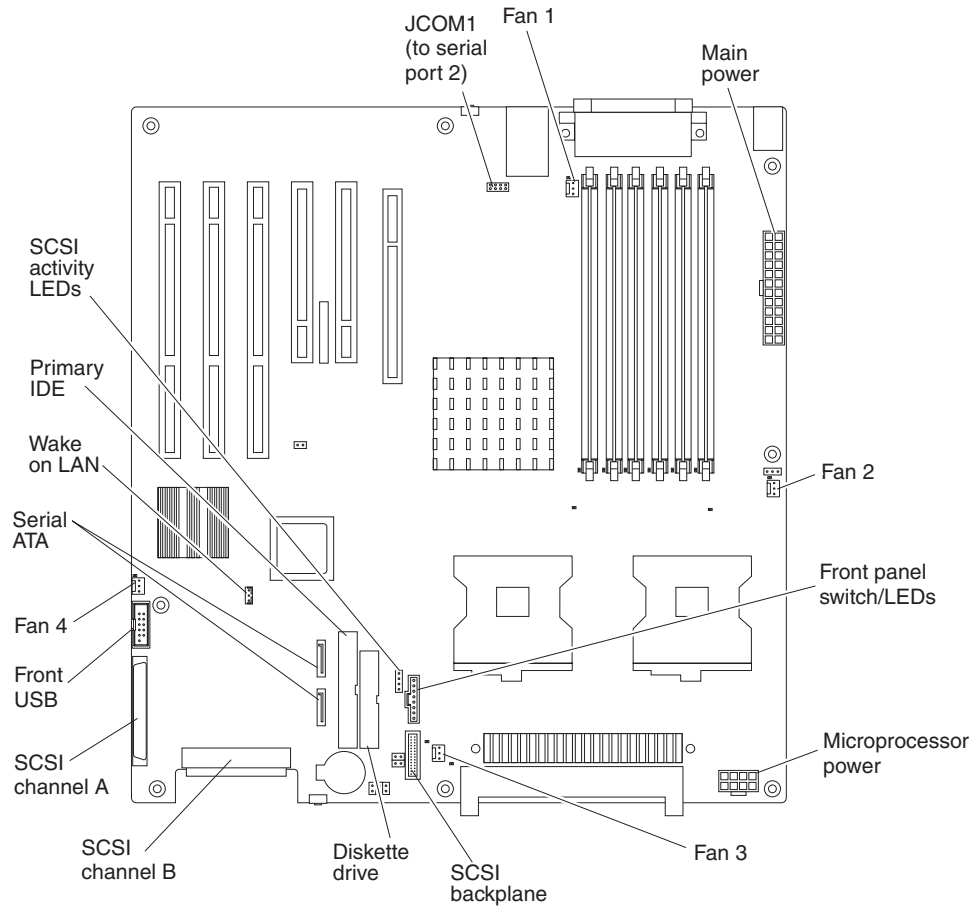

System board external connectors

The following illustration shows the external input/output port connectors on the system board.

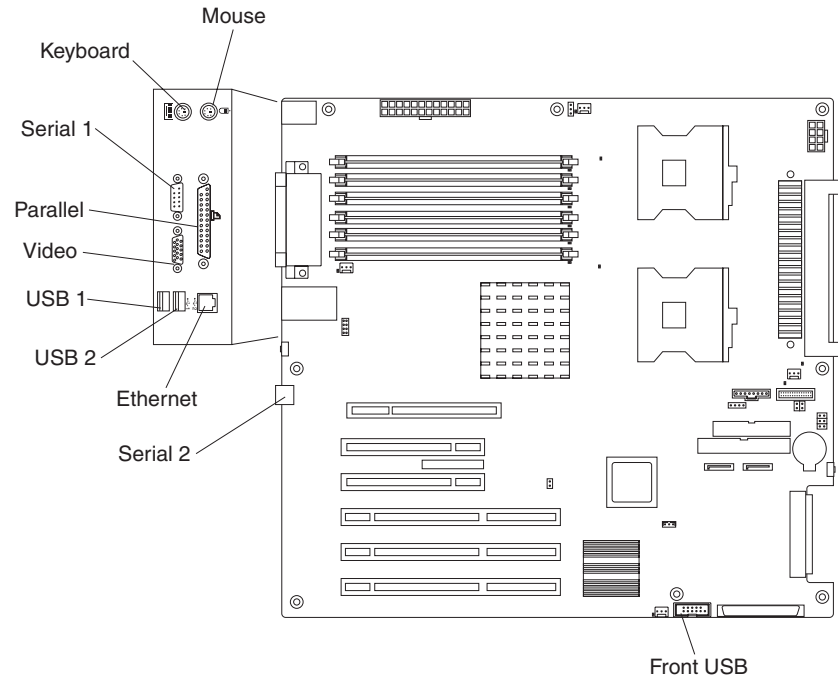

System board error LEDs

The following illustration shows the LEDs on the system board.

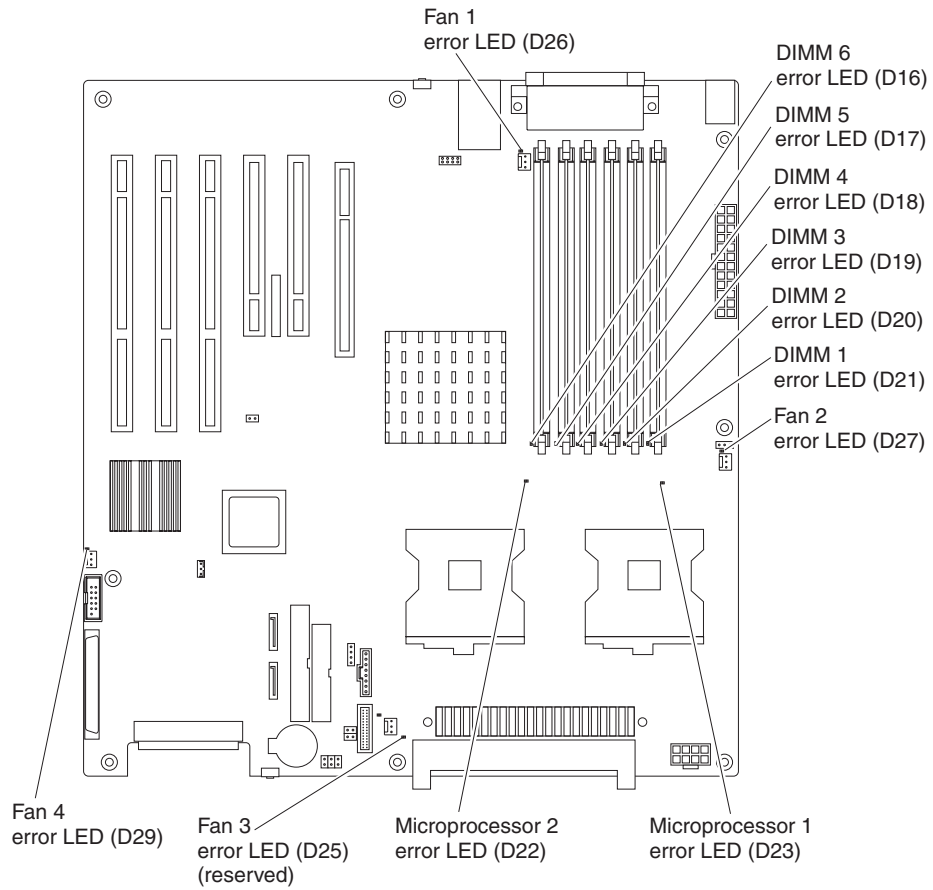

System board jumpers and switches

This section describes the jumpers and switches on the system board.

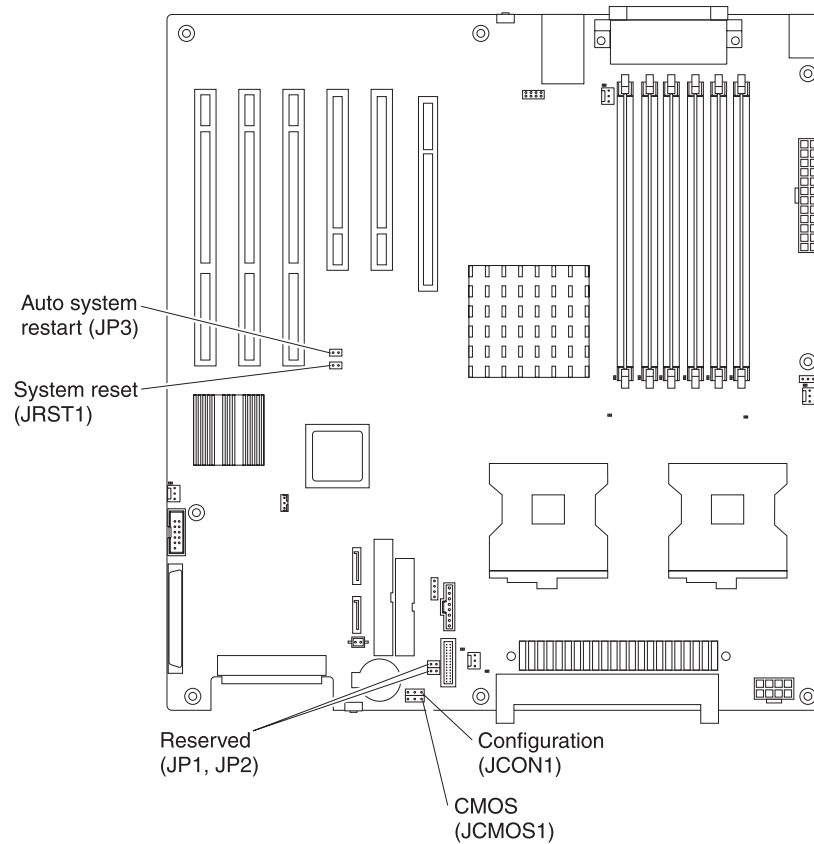

Jumper	Settings
Auto system restart (JP3) (device driver required for ASR functionality)	<ul style="list-style-type: none"> Auto restart enabled (default) (no jumper) Auto restart disabled (with jumper)
Configuration (JCON1)	<ul style="list-style-type: none"> Normal (default) (jumper on pins 1 and 2) Configuration (jumper on pins 2 and 3) BIOS crisis recovery (no jumper)
CMOS (JCMOS1)	<ul style="list-style-type: none"> Keep CMOS data (default) (jumper on pins 1 and 2) Clear CMOS data (jumper on pins 2 and 3 with power cords removed from server)
Reserved (JP1, JP2)	<ul style="list-style-type: none"> No jumper (default)
System reset (JRST1)	<ul style="list-style-type: none"> Normal (default) (no jumper) Force system reset (debug only) (with jumper)

Removing the system board

Before you begin:

- Read Appendix B, “Safety information,” on page 127.
- Review the information in “System reliability considerations” on page 23.

Notes:

1. When replacing the system board, you must either update the server with the latest firmware or restore the pre-existing firmware that the customer provides on a diskette or CD image.
2. Removing the system board will be easier if the server is turned on its side.

To remove the system board, complete the following steps:

1. Turn off the server, if it is on.
2. Disconnect the power cord from the power source and from the server; then, disconnect all external cables.
3. Remove the side cover (see “Removing the side cover” on page 25).
4. Rotate the drive cage to its upright position.
5. Remove the microprocessor air baffle.
6. Remove the adapters (see “Installing an adapter” on page 26).
7. Remove the heat sinks (see “Microprocessor and heat sink” on page 60).
8. Disconnect the cables on the system board, noting their locations.

Note: See the system service label or “System board internal connectors” on page 72 for system board connector locations.

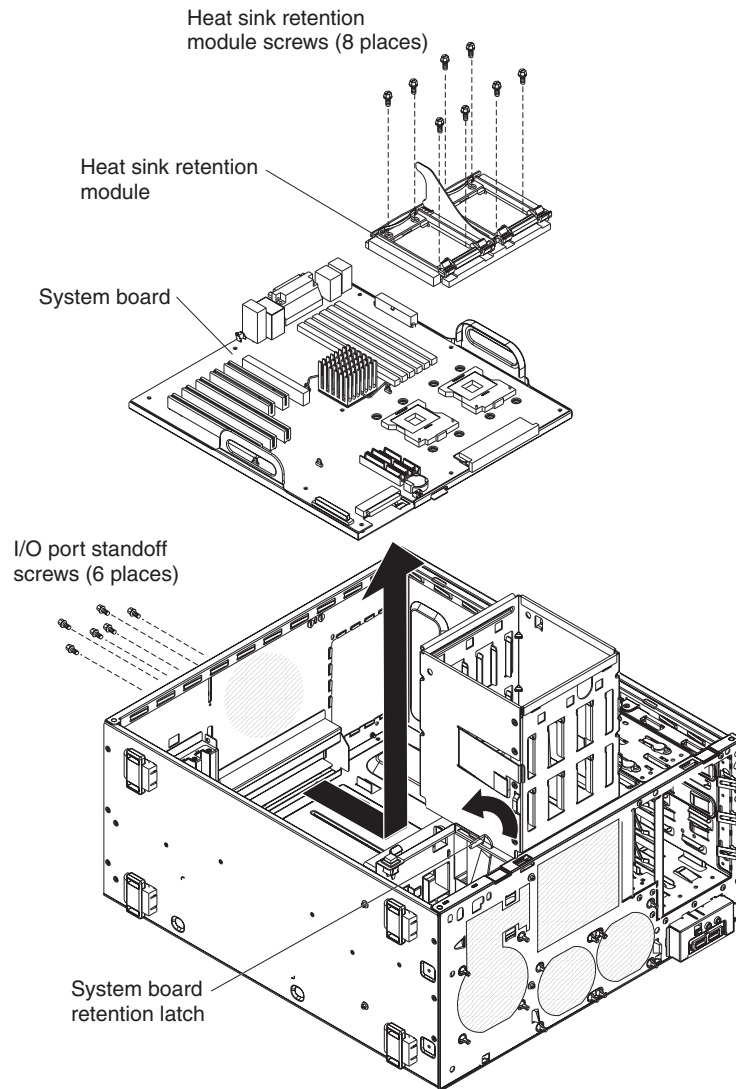

9. Remove the six I/O port standoff screws and set them in a safe place.
10. Remove the eight heat sink retention module screws and set them in a safe place; then, remove the heat sink retention module.
11. Move the retention latch toward the rear of the computer.
12. Grasp the sides of the system board assembly and slide it toward the front of the computer until it detaches from the chassis; then, lift it out.

To replace the system board, reverse the previous steps.

Top/side cover

Before you begin:

- Read Appendix B, “Safety information,” on page 127.
- Review the information in “System reliability considerations” on page 23.

To remove the top/side cover, complete the following steps:

1. Turn off the computer, if it is on.
2. Disconnect the power cord from the power source and from the computer; then, disconnect all external cables.
3. Remove the side cover (see “Removing the side cover” on page 25).
4. Remove the front bezel (see “Removing the bezel” on page 26).
5. Remove the handle assembly (see “Handle assembly” on page 81).
6. Remove the four screws from the back of the computer and put them in a safe place.
7. Using a screwdriver, gently pry the cover away from the computer in the rear and slide the unit away from the computer.

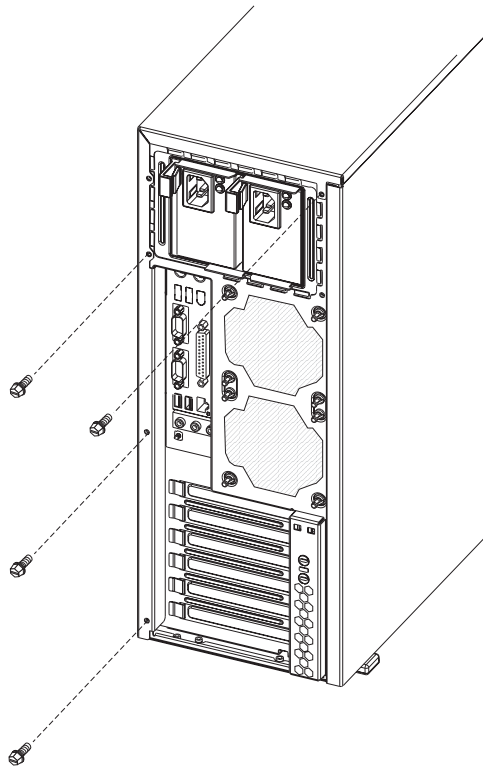

To replace the top/side cover, reverse the steps.

Bezel-release latch

Before you begin:

- Read Appendix B, “Safety information,” on page 127.
- Review the information in “System reliability considerations” on page 23.

To remove the bezel-release latch, complete the following steps:

1. Turn off the computer, if it is on.
2. Disconnect the power cord from the power source and from the computer; then, disconnect all external cables.
3. Remove the side cover (see “Removing the side cover” on page 25).
4. Remove the front bezel (see “Removing the bezel” on page 26).
5. Remove the CD-ROM drive (see “CD-ROM drive” on page 61).
6. Pull down from inside the computer to release the latch tab.
7. From the underside, grasp the bezel-release latch in the center, and gently pull it back and away from the computer.

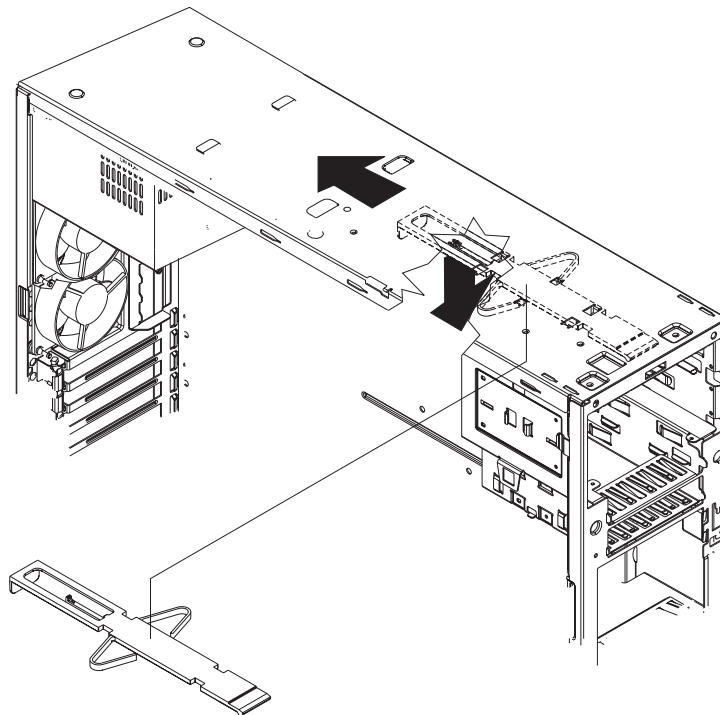

To replace the bezel-release latch, complete the following steps:

1. Align the bezel-release latch with the slots on the underside of the top of the chassis, and slide it into place.

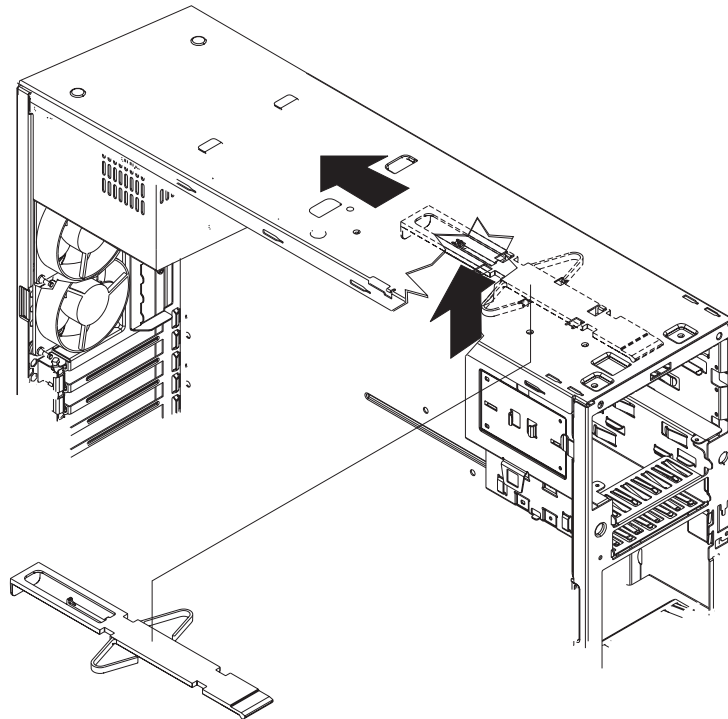

2. Replace the CD-ROM drive (see “Installing a drive in bay 2 or 3” on page 32).
3. Replace the front bezel (see “Replacing the bezel” on page 50).
4. Replace the side cover (see “Replacing the side cover” on page 51).
5. Connect all external cables; then, connect the power cord, and reconnect the computer to power.
6. Turn on the computer.

Handle assembly

Before you begin:

- Read Appendix B, “Safety information,” on page 127.
- Review the information in “System reliability considerations” on page 23.

To remove the handle cap, complete the following steps:

1. Turn off the computer, if it is on.
2. Disconnect the power cord from the power source and from the computer; then, disconnect all external cables.
3. Use a flathead screwdriver to gently press in and down on the tabs on the interior side wall of the handle.

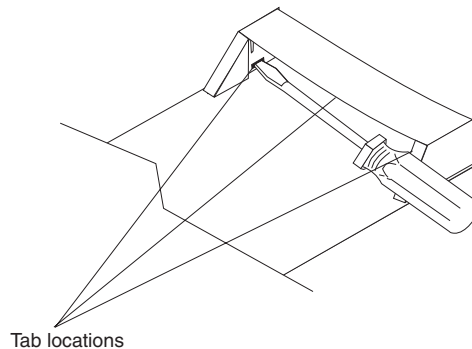

4. Lift up on the handle cap to separate it from the handle support.
5. Turn the system back to the tower orientation; then, remove the top handle.
 - a. Carefully use a flat-blade screwdriver to push in the tabs inside the plastic cover on the top of the system; then, remove the plastic cover. Store the cover for possible future use.
 - b. Grasp the metal handle and slide it toward the rear of the computer to remove it from the computer. Store the metal handle for possible future use.

To remove the handle support, complete the following steps:

1. Turn off the computer, if it is on.
2. Disconnect the power cord from the power source and from the computer; then, disconnect all external cables.
3. Firmly grasp the handle support, and slide it away from the front bezel.
4. Lift up on the handle support to remove it from the slots in the top of the chassis.

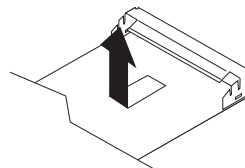

To install the handle assembly, reverse the steps.

Chapter 6. Symptom-to-FRU index

This index supports IntelliStation Z Pro Types 6223 and 6227 computers.

Notes:

1. Check the configuration before you replace a CRU or FRU. Configuration problems can cause false errors and symptoms.
2. For IBM devices that are not supported by this index, see the documentation for that device.
3. Always start with “General checkout” on page 13.

The symptom-to-FRU index lists symptoms, errors, and the possible causes. The most likely cause is listed first. Use this symptom-to-FRU index to help you decide which FRUs to have available when servicing the computer.

The first column of the two-column tables in this index lists error codes or messages, and the last column lists one or more suggested actions or FRUs to replace. Take the action (or replace the FRU) that is suggested first in the list, and then try the computer again to see whether the problem has been corrected.

Note: Try reseating a suspected component or reconnecting a cable before replacing the component.

The POST BIOS code displays POST error codes and messages on the screen.

Beep symptoms

Beep symptoms are short tones or a series of short tones separated by pauses (intervals without sound). See the examples in the following table.

Beeps	Description
1-2-3	<ul style="list-style-type: none">• One beep• A pause (or break)• Two beeps• A pause (or break)• Three beeps
4	Four continuous beeps

One beep after successfully completing POST indicates the computer is functioning properly.

Note: See “System replaceable units” on page 117 to determine which components should be replaced by a field service technician.	
Beep/symptom	FRU/action
1-1-2 (Microprocessor register test failed.)	<ul style="list-style-type: none">• Microprocessor
1-1-3 (CMOS write/read test failed.)	<ol style="list-style-type: none">1. Battery2. System board
1-1-4 (BIOS EEPROM checksum failed.)	<ol style="list-style-type: none">1. Recover BIOS2. System board

Note: See “System replaceable units” on page 117 to determine which components should be replaced by a field service technician.

Beep/symptom	FRU/action
1-2-1 (Programmable Interval Timer failed.)	• System board
1-2-2 (DMA page register test failed.)	• System board
1-2-3 (DMA page register write/read failed.)	• System board
1-3-1 (First 64K RAM test failed.)	1. DIMM 2. Memory adapter
2-1-1 (Secondary DMA register failed.)	• System board
2-1-2 (Primary DMA register failed.)	• System board
2-1-3 (Primary interrupt mask register failed.)	• System board
2-1-4 (Secondary interrupt mask register failed)	• System board
2-2-2 (Keyboard controller failed.)	1. Keyboard 2. System board
2-2-3 (CMOS power failure and checksum check failed.)	1. Battery 2. System board
2-4-1 (Video failed; system believed operable.)	• System board
3-1-1 (Timer tick interrupt failed.)	• System board
3-1-2 (Interval timer channel 2 failed.)	• System board
3-1-3 (RAM test failed above address OFFFFH.)	1. DIMM 2. System board
3-1-4 (Time-Of-Day clock failed.)	1. Battery 2. System board
3-2-1 (Serial port failed.)	• System board
3-2-2 (Parallel port failed.)	• System board
3-2-3 (Math coprocessor test failed.)	1. Optional microprocessor 2. Microprocessor 3. System board

Note: See “System replaceable units” on page 117 to determine which components should be replaced by a field service technician.

Beep/symptom	FRU/action
3-2-4 (Failure comparing CMOS memory size against actual.)	<ol style="list-style-type: none"> 1. DIMM 2. Battery 3. System board
3-3-1 (Memory size mismatch occurred.)	<ol style="list-style-type: none"> 1. DIMM 2. Battery 3. System board
3-3-2 (Critical SMBus error occurred, I2C error)	<ol style="list-style-type: none"> 1. Disconnect the computer power cord from outlet, wait 30 seconds, and retry. 2. Microprocessor 3. DIMMs 4. SCSI backplane 5. SCSI power cable 6. System board

No-beep symptoms

Note: See “System replaceable units” on page 117 to determine which components should be replaced by a field service technician.

No-beep symptom	FRU/action
No beep occurs during POST.	<ul style="list-style-type: none"> • System board
No beep, no video, and the system attention LED is off.	<ul style="list-style-type: none"> • System board
No beep, no video, and a system board error LED is on.	<ul style="list-style-type: none"> • See “System board error LEDs” on page 74.
BIST failed.	<ul style="list-style-type: none"> • Microprocessor

POST error codes

In the following error codes, X can be any number or letter.

Note: See “System replaceable units” on page 117 to determine which components should be replaced by a field service technician.

Error code/symptom	FRU/action
062 (Three consecutive boot failures using the default configuration.)	<ol style="list-style-type: none"> 1. Run the Configuration/Setup Utility program. 2. Battery. 3. System board. 4. Microprocessor.
101, 102, 106 (Timer tick interrupt failure)	<ul style="list-style-type: none"> • System board
102 (Timer 2 test failure)	<ul style="list-style-type: none"> • System board
106 (Diskette controller error)	<ul style="list-style-type: none"> • System board

Note: See “System replaceable units” on page 117 to determine which components should be replaced by a field service technician.

Error code/symptom	FRU/action
129 (Internal cache (L1) error)	<ol style="list-style-type: none"> 1. Optional microprocessor 2. Microprocessor
151 (Real time clock error)	<ol style="list-style-type: none"> 1. Battery 2. System board
161 (Real time clock battery error)	<ol style="list-style-type: none"> 1. Run the Configuration/Setup Utility program. 2. Battery. 3. System board.
162 (Device configuration error) Note: Be sure to load the default settings and any additional desired settings; then, <i>save the configuration.</i>	<ol style="list-style-type: none"> 1. Run the Configuration/Setup Utility program. 2. Battery. 3. Failing device. 4. System board.
163 (Real-time clock error)	<ol style="list-style-type: none"> 1. Run the Configuration/Setup Utility program. 2. Battery. 3. System board.
164 (Memory configuration changed.)	<ol style="list-style-type: none"> 1. Run the Configuration/Setup Utility program. 2. DIMM. 3. System board.
175 (EEPROM CRC #1 damaged.)	<ol style="list-style-type: none"> 1. If Remote Supervisor Adapter II is installed, make sure that the latest firmware is installed. 2. System board
184 (Power-on password damaged)	<ol style="list-style-type: none"> 1. Run the Configuration/Setup Utility program. 2. System board.
185 (Drive startup sequence information corrupted)	<ol style="list-style-type: none"> 1. Run the Configuration/Setup Utility program. 2. System board.
187 (VPD serial number not set.)	<ol style="list-style-type: none"> 1. Set serial number in the Configuration/Setup Utility program. 2. System board.
188 (EEPROM CRC #2 damaged.)	<ol style="list-style-type: none"> 1. Run the Configuration/Setup Utility program. 2. System board.
189 (An attempt made to enter the system with invalid passwords)	<ol style="list-style-type: none"> 1. Run the Configuration/Setup Utility program. 2. System board.
196 (Microprocessor cache mismatch)	<ol style="list-style-type: none"> 1. Make sure that microprocessors are of same type and speed. 2. Microprocessor.
198 (Microprocessor speed mismatch)	<ol style="list-style-type: none"> 1. Make sure that microprocessors are of same type and speed. 2. Microprocessor.
199 (Microprocessors not in recommended configurations)	<ol style="list-style-type: none"> 1. Make sure that microprocessors are of same type and speed. 2. Microprocessor.
201 (Memory test error.)	<ol style="list-style-type: none"> 1. DIMM 2. System board

Note: See “System replaceable units” on page 117 to determine which components should be replaced by a field service technician.

Error code/symptom	FRU/action
229 (Internal cache (L2) error)	<ol style="list-style-type: none"> 1. Microprocessor 2. Optional microprocessor
289 (DIMM disabled by the user or system.)	<ol style="list-style-type: none"> 1. Run the Configuration/Setup Utility program. 2. DIMM. 3. System board.
301 (Keyboard or keyboard controller error)	<ol style="list-style-type: none"> 1. Keyboard 2. System board
303 (Keyboard controller error)	<ol style="list-style-type: none"> 1. Replace the PS/2 keyboard with a USB keyboard. 2. System board.
602 (Invalid diskette boot record)	<ol style="list-style-type: none"> 1. Diskette 2. Diskette drive 3. Drive cable 4. System board
604 (Diskette drive error)	<ol style="list-style-type: none"> 1. Run the Configuration/Setup Utility program and diagnostics. 2. Diskette drive. 3. Drive cable. 4. System board.
662 (Diskette drive configuration error)	<ol style="list-style-type: none"> 1. Run the Configuration/Setup Utility program and diagnostics. 2. Diskette drive. 3. Drive cable. 4. System board.
962 (Parallel port configuration error)	<ol style="list-style-type: none"> 1. Run the Configuration/Setup Utility program. 2. System board.
1162 (Serial port configuration error)	<ul style="list-style-type: none"> • System board
11XX (System board serial port 1 or 2 error)	<ol style="list-style-type: none"> 1. Run the Configuration/Setup Utility program. 2. System board.
1601 (BIOS code update needed)	<ol style="list-style-type: none"> 1. Download and install latest level of BIOS code. 2. System board.
1602 (Cable for optional Remote Supervisor Adapter II not installed)	<ul style="list-style-type: none"> • Disconnect all computer and option power cords from computer, wait 30 seconds, reconnect, and retry.
1762 (Hard drive configuration error, IDE only.)	<ol style="list-style-type: none"> 1. Hard disk drive. 2. Hard disk cables. 3. Run the Configuration/Setup Utility program. 4. System board.
178X (Hard drive error, IDE only.)	<ol style="list-style-type: none"> 1. Hard disk cables 2. Hard disk adapter 3. Hard disk drive 4. System board

Note: See “System replaceable units” on page 117 to determine which components should be replaced by a field service technician.

Error code/symptom	FRU/action
1800 (No more hardware interrupt available for PCI adapter.)	<ol style="list-style-type: none"> 1. Run the Configuration/Setup Utility program. 2. Remove adapter.
1801 (No more ROM space available for PCI adapter.)	<ol style="list-style-type: none"> 1. Run the Configuration/Setup Utility program. 2. Remove adapter. 3. Disable the adapter BIOS and run the Configuration/Setup Utility program.
1802 (Unavailable I/O address for PCI adapter)	<ol style="list-style-type: none"> 1. Start the Configuration/Setup Utility program and make sure that I/O addresses for all adapters are set correctly. 2. Adapter. 3. System board.
1803 (Unavailable memory address for PCI adapter)	<ol style="list-style-type: none"> 1. Start the Configuration/Setup Utility program and make sure that memory addresses for all other adapters are set correctly. 2. Adapter. 3. System board.
1804 (Unavailable memory address for PCI adapter)	<ol style="list-style-type: none"> 1. Remove an adapter to make memory address space available. 2. Disable adapter BIOS on adapter. 3. Adapter. 4. System board.
1805 (PCI ROM error occurred)	<ol style="list-style-type: none"> 1. Remove all adapters and reinstall one at a time, restarting the computer each time, until the failing adapter is determined; then, replace that adapter. 2. System board.
1806 (PCI-to-PCI bridge error occurred)	<ol style="list-style-type: none"> 1. Remove all adapters and reinstall one at a time, restarting the computer each time, until the failing adapter is determined; then, replace that adapter. 2. System board.
1807 (xxxxyyyy PCI device unresponsive or disabled by user, where xxxx=PCI vendor ID and yyyy=PCI device ID)	<ol style="list-style-type: none"> 1. Run the Configuration/Setup Utility program and make sure the device is enabled. 2. Adapter. 3. System board.
1808 (Unsupported PCI device is installed)	<ol style="list-style-type: none"> 1. Remove all adapters and reinstall one at a time, restarting the computer each time, until the failing adapter is determined; then, replace that adapter. 2. System board.
1962 (Drive does not contain a valid boot sector)	<ol style="list-style-type: none"> 1. Verify that a startable operating system is installed. 2. Run diagnostics. 3. Hard disk drive. 4. SCSI backplane. 5. Cable. 6. System board.
2400 (Video controller test failure)	<ol style="list-style-type: none"> 1. Video adapter (if installed) 2. System board.

Note: See “System replaceable units” on page 117 to determine which components should be replaced by a field service technician.

Error code/symptom	FRU/action
2462 (Video configuration error)	<ol style="list-style-type: none"> 1. Video adapter (if installed) 2. System board.
5962 (IDE CD-ROM drive configuration error)	<ol style="list-style-type: none"> 1. Run the Configuration/Setup Utility program. 2. CD-ROM drive. 3. CD-ROM power cable. 4. IDE cable. 5. System board. 6. Battery.
8603 (Pointing-device error)	<ol style="list-style-type: none"> 1. Pointing device 2. System board
00012000 (Machine check architecture error.)	<ol style="list-style-type: none"> 1. Microprocessor 2. System board.
00019502 (Microprocessor 1 failed)	<ol style="list-style-type: none"> 1. Microprocessor 2. System board
00019xxx (Microprocessor x not functioning)	<ol style="list-style-type: none"> 1. Verify microprocessor x is installed correctly. 2. Microprocessor x. 3. VRM, if installed. 4. System board.
00151200 (Unrecoverable error, microprocessor x reported IERR)	<ol style="list-style-type: none"> 1. Microprocessor x 2. VRM 3. System board
00180100 (No room for PCI option ROM)	<ol style="list-style-type: none"> 1. Run the Configuration/Setup Utility program. 2. Failing adapter. 3. System board.
00180200 (No more I/O space available for PCI adapter.)	<ol style="list-style-type: none"> 1. Run the Configuration/Setup Utility program. 2. Adapter. 3. System board.
00180300 (No more memory above 1MB for PCI adapter.)	<ol style="list-style-type: none"> 1. Run the Configuration/Setup Utility program. 2. Adapter. 3. System board.
00180400 (No memory below 1 MB for PCI adapter.)	<ol style="list-style-type: none"> 1. Run the Configuration/Setup Utility program. 2. Adapter. 3. System board.
00180500 (PCI option ROM checksum error.)	<ol style="list-style-type: none"> 1. PCI adapter. 2. System board.
00180600 (PCI device BIST failure. PCI bridge error.)	<ol style="list-style-type: none"> 1. Run the Configuration/Setup Utility program. 2. Adapter. 3. System board.
00180700 (PCI device not responding.)	<ol style="list-style-type: none"> 1. PCI adapter. 2. System board.

Note: See “System replaceable units” on page 117 to determine which components should be replaced by a field service technician.

Error code/symptom	FRU/action
00180xxx (PCI adapter has requested resources that are not available)	<ol style="list-style-type: none"> 1. Reorder adapters in PCI slots. 2. Verify that boot device is positioned early in the scan order so that it is executed by POST. 3. Verify that all adapters are set correctly in Configuration/Setup Utility program, changing memory settings if necessary. 4. Remove an adapter to make more memory available to the adapters. 5. Disable adapter BIOS on adapter (see documentation provided with adapter). 6. System board.
00181000 (General PCI error)	<ol style="list-style-type: none"> 1. Adapter 2. System board
012980xx (Microprocessor 1 error)	<ol style="list-style-type: none"> 1. Verify both microprocessors have same cache size and type and the same clock speed. 2. Download and update the BIOS code. 3. Microprocessor 1. 4. System board.
012981xx (Microprocessor 2 error)	<ol style="list-style-type: none"> 1. Verify both microprocessors have same cache size and type and the same clock speed. 2. Download and update the BIOS code. 3. Microprocessor 2. 4. System board.
I9990301 (Invalid boot record on hard disk)	<ol style="list-style-type: none"> 1. Partition and format hard disk drive. 2. Cable. 3. Hard disk drive. 4. Adapter/system board.
I9990650 (AC power has been restored)	<ol style="list-style-type: none"> 1. Check cable. 2. Check for interruption of power. 3. Power cable.

Diagnostic error codes

Note: In the following error codes, if XXX is 000, 195, or 197 *do not* replace a FRU. The description for these error codes are:

- 000** The test passed.
- 195** The Esc key was pressed to abort the test.
- 197** Warning; a hardware failure might not have occurred.

For all error codes, replace or follow the indicated FRU or action.

Error code/symptom	FRU/action
001-XXX-000 (Failed core tests)	• System board
001-XXX-001 (Failed core tests)	• System board

Error code/symptom	FRU/action
001-250-000 (Failed system board ECC)	• System board
001-250-001 (Failed Processor Board ECC)	• System board
001-292-000 (Core system: failed/CMOS checksum failed)	• Load BIOS code defaults and rerun test.
005-XXX-000 (Failed Video test)	1. Video adapter 2. System board
011-XXX-000 (Failed COM1 Serial Port test)	1. Check loopback plug connected to externalized serial port. 2. System board.
011-XXX-001 (Failed COM2 Serial Port test)	1. Check loopback plug connected to externalized serial port. 2. Check cable from externalized port to system board. Should connect to serial port B on the system board (JCOM1). 3. System board.
014-XXX-000 (Failed Parallel Port test)	• System board
015-XXX-001 (USB interface not found, board damaged)	• System board
015-XXX-198 (Remote Supervisor Adapter II installed) or (USB device connected during USB test)	1. If Remote Supervisor Adapter II is installed as an option, remove it and rerun test. Note: If Remote Supervisor Adapter II is present as a standard installation, do not remove it; the test cannot be run. 2. Remove USB devices and rerun test. 3. System board .
020-XXX-000 (Failed PCI Interface test)	• System board
030-XXX-000 (Failed Internal SCSI interface test)	• System board
035-XXX-099 (No adapters were found)	• If an adapter is installed re-check the connection.
035-XXX-S99 (Failed RAID test on PCI slot S, check System Error Log before replacing a FRU)	1. RAID adapter 2. SCSI backplane 3. Cable
035-XXX-SNN (Check System Error Log before replacing a FRU, NN = SCSI ID of failing fixed disk)	• Hard disk with SCSI ID NN on RAID adapter in PCI slot S.
035-253-S99 (RAID adapter initialization failure)	1. ServeRAID Adapter in slot S is not configured properly. Obtain the basic and extended configuration status and see the <i>ServeRAID Hardware Maintenance Manual</i> for more information. 2. Cable. 3. SCSI backplane. 4. Adapter.
089-XXX-001 (Failed Microprocessor test)	1. Microprocessor 1 2. System board
089-XXX-002 (Failed Optional Microprocessor test)	1. Microprocessor 2 2. System board

Error code/symptom	FRU/action
165-060-000 (Service Processor: RSA may be busy)	<ol style="list-style-type: none"> 1. Rerun the diagnostic test. 2. Fix other error conditions that might be keeping the Remote Supervisor Adapter II busy. Refer to the error log and diagnostic panel. 3. Disconnect all computer and option power cords from the computer, wait 30 seconds, reconnect, and retry. 4. System board.
165-198-000 (Service Processor: Aborted)	<ol style="list-style-type: none"> 1. Rerun the diagnostic test. 2. Fix other error conditions that might be keeping the Remote Supervisor Adapter II busy. Refer to the error log and diagnostic panel. 3. Disconnect all computer and option power cords from the computer, wait 30 seconds, reconnect, and retry. 4. System board.
165-201-000 (Service Processor: Failed)	<ol style="list-style-type: none"> 1. Disconnect all computer and option power cords from computer, wait 30 seconds, reconnect, and retry. 2. System board.
165-330-000 (Service Processor: Failed)	<ul style="list-style-type: none"> • Update to the latest ROM diagnostic level, and retry.
165-342-000 (Service Processor: Failed)	<ol style="list-style-type: none"> 1. Make sure that the latest firmware levels for Remote Supervisor Adapter II and BIOS are installed. 2. Disconnect all computer and option power cords from computer, wait 30 seconds, reconnect, and retry. 3. System board.
166-198-000 System Management: Aborted (Unable to communicate with RSA. It may be busy. Run the test again.)	<ol style="list-style-type: none"> 1. Run the diagnostic test again. 2. Correct other error conditions and retry. These include other failed system-management tests and items that are logged in the system-error log of the optional Remote Supervisor Adapter II. 3. Disconnect all computer and option power cords from the computer, wait 30 seconds, reconnect, and retry. 4. Remote Supervisor Adapter II. 5. System board.
166-201-001 System Management: Failed (I2C bus error(s). See SERVPROC and DIAGS entries in event log.)	<ol style="list-style-type: none"> 1. Reseat the I2C cable between the Remote Supervisor Adapter II and the system board. 2. Reseat DIMMs. 3. DIMMs. 4. System board.
166-250-000 System Management: Failed (I2C cable is disconnected. Reconnect I2C cable between Remote Supervisor Adapter and system board.)	<ol style="list-style-type: none"> 1. Reseat the I2C cable between the Remote Supervisor Adapter II and the system board. 2. Remote Supervisor Adapter II. 3. System board.
166-260-000 System Management: Failed (Restart RSAError. After restarting, RSA communication was lost.)	<ol style="list-style-type: none"> 1. Disconnect all computer and option power cords from the computer, wait 30 seconds, reconnect, and retry. 2. Reseat the Remote Supervisor Adapter II. 3. Remote Supervisor Adapter II.

Error code/symptom	FRU/action
166-342-000 System Management: Failed (RSA BIST indicate failed tests.)	<ol style="list-style-type: none"> Make sure that the latest firmware levels for Remote Supervisor Adapter II and BIOS are installed. Disconnect all computer and option power cords from the computer, wait 30 seconds, reconnect, and retry. Remote Supervisor Adapter II.
180-XXX-000 (Diagnostics LED failure)	<ul style="list-style-type: none"> Run diagnostic LED test for the failing LED.
180-XXX-001 (Failed Front LED panel test)	<ul style="list-style-type: none"> Information LED panel
180-XXX-002 (Failed Diagnostics LED panel test)	<ul style="list-style-type: none"> System board
180-XXX-003 (Failed system board LED test)	<ul style="list-style-type: none"> System board
180-XXX-005 (Failed SCSI Backplane LED test)	<ol style="list-style-type: none"> SCSI backplane SCSI backplane cable System board
201-XXX-0NN (Failed Memory test, see "Installing memory modules" on page 41)	<ol style="list-style-type: none"> DIMM Location slots 1-6 where NN = DIMM location. Note: NN 1=DIMM 1 NN 2=DIMM 2 NN 3=DIMM 3 NN 4=DIMM 4 NN 5=DIMM 5 NN 6=DIMM 6 System board
202-XXX-001 (Failed System Cache test)	<ol style="list-style-type: none"> Microprocessor 1 System board
202-XXX-002 (Failed System Cache test)	<ol style="list-style-type: none"> Microprocessor 2 System board
206-XXX-000 (Failed Diskette Drive test)	<ol style="list-style-type: none"> Rerun the test with another diskette. Diskette drive cables. Diskette drive. System board.
214-XXX-000 (Failed Diskette Drive test)	<ol style="list-style-type: none"> Rerun the test with another diskette. Cable. Diskette drive. System board.
215-XXX-000 (Failed IDE CD-ROM test)	<ol style="list-style-type: none"> Rerun the test with a different CD. CD-ROM drive cables. CD-ROM drive. System board.
217-198-XXX (Could not establish drive parameters)	<ol style="list-style-type: none"> Check the cable and termination. SCSI backplane. Hard disk drive. .
217-XXX-000 (Failed Fixed Disk test) Note: If RAID is configured, the fixed disk number refers to the RAID logical array.	<ol style="list-style-type: none"> Fixed Disk 1 System board
217-XXX-001 (Failed BIOS Fixed Disk test) Note: If RAID is configured, the fixed disk number refers to the RAID logical array.	<ol style="list-style-type: none"> Fixed Disk 2 System board

Error code/symptom	FRU/action
217-XXX-002 (Failed Fixed Disk test) Note: If RAID is configured, the fixed disk number refers to the RAID logical array.	<ol style="list-style-type: none"> 1. Fixed Disk 3 2. System board
217-XXX-003 (Failed Fixed Disk test) Note: If RAID is configured, the fixed disk number refers to the RAID logical array.	<ol style="list-style-type: none"> 1. Fixed Disk 4 2. System board
217-XXX-004 (Failed Fixed Disk test) Note: If RAID is configured, the fixed disk number refers to the RAID logical array.	<ol style="list-style-type: none"> 1. Fixed Disk 5 2. System board
217-XXX-005 (Failed Fixed Disk test) Note: If RAID is configured, the fixed disk number refers to the RAID logical array.	<ol style="list-style-type: none"> 1. Fixed Disk 6 2. System board
264-XXX-0NN (Failed Tape Drive test)	<ol style="list-style-type: none"> 1. Tape cartridge, if the user ran the Read/Write Tape Drive test (failure code of XXX = 256). 2. SCSI or power cable connected to the tape drive with SCSI ID NN. 3. Tape drive with SCSI ID NN. (See the help and service information appendix of the tape drive user guide.) 4. System board or SCSI controller. (Run SCSI controller diagnostic to determine if the SCSI bus is functioning properly.)
264-XXX-999 (Errors on multiple tape drives, see error text for more info)	<ul style="list-style-type: none"> • See error messages and text in the PC Doctor error log for detailed information about each individual tape drive error.
301-XXX-000 (Failed Keyboard test)	<ol style="list-style-type: none"> 1. Keyboard 2. System board
405-XXX-000 (Failed Ethernet test on controller on the system board)	<ol style="list-style-type: none"> 1. Make sure that Ethernet is not disabled in BIOS. 2. System board.
405-XXX-A0N (Failed Ethernet test on adapter in slot A)	<ol style="list-style-type: none"> 1. For A=0, system board 2. For A >0, adapter in PCI slot A
415-XXX-000 (Failed Modem test)	<ol style="list-style-type: none"> 1. Cable Note: Make sure that the modem is present and attached to the computer. 2. Modem 3. System board

Diagnostic error LEDs

Lit LED	FRU/action
DIMM x (where x = DIMM 1-6; see "System board error LEDs" on page 74)	<ol style="list-style-type: none"> DIMM x System board
Microprocessor x (where x = 1-2; see "System board error LEDs" on page 74)	<ol style="list-style-type: none"> Microprocessor x System board
Fan x (where x = 1, 2, or 4; see "System board error LEDs" on page 74) Note: This feature is supported with optional Remote Supervisor Adapter II only.	<ol style="list-style-type: none"> Fan x System board
Hard disk drive x (where x = 0-5) Note: LEDs are located on the front of the hot-swap hard disk drives.	<ol style="list-style-type: none"> Hard disk drive x System board

Error symptoms

You can use the error symptom table to find solutions to problems that have definite symptoms.

If you cannot find the problem in the error symptom charts, run the diagnostic programs to test the computer.

If you have just added new software or a new option and the computer is not working, complete the following steps before using the error symptom charts:

1. Remove the software or device that you just added.
2. Run the diagnostic tests to determine whether the computer is running correctly.
3. Reinstall the new software or new device.

In the following table, if the entry in the FRU/action column is a suggested action, perform that action; if it is the name of a component, reseal the component and replace it if necessary. The most likely cause of the symptom is listed first.

CD-ROM drive	
Symptom	FRU/action
CD-ROM drive is not recognized.	<ol style="list-style-type: none"> Verify that: <ul style="list-style-type: none"> • The IDE channel to which the CD-ROM drive is attached (primary or secondary) is enabled in the Configuration/Setup Utility program. • All cables and jumpers are installed correctly. • The correct device driver is installed for the CD-ROM drive. Run CD-ROM drive diagnostics. CD-ROM drive.
CD is not working properly.	<ol style="list-style-type: none"> Clean the CD. Run CD-ROM diagnostics. CD-ROM drive.

Note: See Chapter 7, "Parts listing Types 6223 and 6227," on page 115 to determine which components are replaceable by the customer (CRU), and which components must be replaced by a field service technician (FRU).	
CD-ROM drive	
Symptom	FRU/action
CD-ROM drive tray is not working. (The computer must be powered on.)	<ol style="list-style-type: none"> 1. Insert the end of a paper clip into the manual tray-release opening. 2. Run CD-ROM diagnostics. 3. CD-ROM drive.

Note: See Chapter 7, "Parts listing Types 6223 and 6227," on page 115 to determine which components are replaceable by the customer (CRU), and which components must be replaced by a field service technician (FRU).	
Diskette drive	
Symptom	FRU/action
The diskette drive activity LED stays lit, or the computer bypasses the diskette drive, or the diskette drive does not work.	<ol style="list-style-type: none"> 1. If there is a diskette in the drive, verify that: <ul style="list-style-type: none"> • The diskette drive is enabled in the Configuration/Setup utility program. • The diskette is good and not damaged. (Try another diskette if you have one.) • The diskette is inserted correctly in the drive. • The diskette contains the necessary files to start the computer. • The software program is working properly. • The cable is installed correctly (in the proper orientation). 2. To prevent diskette drive read/write errors, make sure that the distance between monitors and diskette drives is at least 76 mm (3 in.). 3. Run diskette drive diagnostics. 4. Cable. 5. Diskette drive. 6. System board.

Note: See Chapter 7, "Parts listing Types 6223 and 6227," on page 115 to determine which components are replaceable by the customer (CRU), and which components must be replaced by a field service technician (FRU).	
General	
Symptom	FRU/action
Problems such as broken cover locks or indicator LEDs not working	<ul style="list-style-type: none"> • Broken CRU/FRU

Note: See Chapter 7, "Parts listing Types 6223 and 6227," on page 115 to determine which components are replaceable by the customer (CRU), and which components must be replaced by a field service technician (FRU).	
Hard disk drive	
Symptom	FRU/action
Not all drives are recognized by the hard disk drive diagnostic test (Fixed Disk test).	<ol style="list-style-type: none"> 1. Remove the first drive not recognized and try the hard disk drive diagnostic test again. 2. If the remaining drives are recognized, replace the drive you removed with a new one.

Note: See Chapter 7, “Parts listing Types 6223 and 6227,” on page 115 to determine which components are replaceable by the customer (CRU), and which components must be replaced by a field service technician (FRU).

Hard disk drive

Symptom	FRU/action
System stops responding during hard disk drive diagnostic test.	<ol style="list-style-type: none"> 1. Remove the hard disk drive being tested when the computer stopped responding and try the diagnostic test again. 2. If the hard disk drive diagnostic test runs successfully, replace the drive you removed with a new one.

Note: See Chapter 7, “Parts listing Types 6223 and 6227,” on page 115 to determine which components are replaceable by the customer (CRU), and which components must be replaced by a field service technician (FRU).

Intermittent

Symptom	FRU/action
A problem occurs only occasionally and is difficult to detect.	<ol style="list-style-type: none"> 1. Verify that: <ul style="list-style-type: none"> • All cables and cords are connected securely to the rear of the computer and attached options. • When the computer is turned on, air is flowing from the rear of the computer at the fan grill. If there is no airflow, the fan is not working. This causes the computer to overheat and shut down. • Ensure that the SCSI bus and devices are configured correctly and that the last external device in each SCSI chain is terminated correctly. 2. Check the system error log.

Note: See Chapter 7, “Parts listing Types 6223 and 6227,” on page 115 to determine which components are replaceable by the customer (CRU), and which components must be replaced by a field service technician (FRU).

Keyboard, mouse, or pointing-device

Symptom	FRU/action
All or some keys on the keyboard do not work.	<ol style="list-style-type: none"> 1. Verify that: <ul style="list-style-type: none"> • The keyboard cable is securely connected to the system, and the keyboard and mouse cables are not reversed. • The computer and the monitor are turned on. 2. Keyboard. 3. System board.
The mouse or pointing device does not work.	<ol style="list-style-type: none"> 1. Verify that: <ul style="list-style-type: none"> • The mouse or pointing-device cable is securely connected, and that the keyboard and mouse cables are not reversed. • The mouse device drivers are installed correctly. 2. Mouse or pointing device. 3. System board.

Note: See Chapter 7, "Parts listing Types 6223 and 6227," on page 115 to determine which components are replaceable by the customer (CRU), and which components must be replaced by a field service technician (FRU).

Memory	
Symptom	FRU/action
The amount of system memory displayed is less than the amount of physical memory installed.	<ol style="list-style-type: none"> 1. Verify that: <ul style="list-style-type: none"> • The memory modules are seated properly. • You have installed the correct type of memory. • If you changed the memory, you updated the memory configuration with the Configuration/Setup Utility program. • All banks of memory on the DIMMs are enabled. The computer might have automatically disabled a DIMM bank when it detected a problem or a DIMM bank could have been manually disabled. 2. Check POST error log for error message 289: <ul style="list-style-type: none"> • If the DIMM was disabled by a system-management interrupt (SMI), replace the DIMM. • If the DIMM was disabled by the user or by POST: <ol style="list-style-type: none"> a. Start the Configuration/Setup Utility program. b. Enable the DIMM. c. Save the configuration and restart the computer. 3. DIMM. 4. System board.

Note: See Chapter 7, "Parts listing Types 6223 and 6227," on page 115 to determine which components are replaceable by the customer (CRU), and which components must be replaced by a field service technician (FRU).

Microprocessor	
Symptom	FRU/action
The computer emits a continuous tone during POST. (The startup (boot) microprocessor is not working properly.)	<ol style="list-style-type: none"> 1. Verify that the startup microprocessor is seated properly. 2. Startup microprocessor.

Note: See Chapter 7, "Parts listing Types 6223 and 6227," on page 115 to determine which components are replaceable by the customer (CRU), and which components must be replaced by a field service technician (FRU).

Monitor	
Symptom	FRU/action
Monitor problems (general).	<p>Some IBM monitors have their own self-tests. If you suspect a problem with the monitor, refer to the information that comes with the monitor for adjusting and testing instructions.</p> <ol style="list-style-type: none"> 1. Monitor. 2. Run video diagnostics. If diagnostics pass, the problem may be a video driver. 3. Display adapter / system board.

Note: See Chapter 7, “Parts listing Types 6223 and 6227,” on page 115 to determine which components are replaceable by the customer (CRU), and which components must be replaced by a field service technician (FRU).

Monitor	
Symptom	FRU/action
The screen is blank.	<ol style="list-style-type: none"> 1. Verify that: <ul style="list-style-type: none"> • The computer power cord is connected to the computer and a working electrical outlet. • The monitor cables are connected properly. • The monitor is turned on and the brightness and contrast controls are adjusted correctly. • If the computers are C2T chained together, verify that: <ul style="list-style-type: none"> – The C2T chain cables are securely connected to the computers. – The C2T breakout cable is connected properly. – A computer that is turned on is selected. <p>Important: In some memory configurations, the 3-3-3 beep code might sound during POST followed by a blank display screen. If this occurs and the Boot Fail Count feature in the Start Options of the Configuration/Setup Utility program is set to Enabled (its default setting), you must restart the computer three times to force the system BIOS to reset the CMOS values to the default configuration (memory connector or bank of connectors enabled).</p> <p>If you have installed a Remote Supervisor Adapter II in the computer, make sure that the video cable is connected to the Remote Supervisor Adapter II.</p> 2. Make sure that damaged BIOS code is not affecting the video; see “Recovering from a POST/BIOS update failure” on page 19. 3. If you have verified these items and the screen remains blank, replace: <ol style="list-style-type: none"> a. Monitor b. Video adapter, if installed c. System board
Only the cursor appears.	<ul style="list-style-type: none"> • See “Undetermined problems” on page 113.
The monitor works when you turn on the computer but goes blank when you start some application programs.	<ol style="list-style-type: none"> 1. Verify that: <ul style="list-style-type: none"> • The application program is not setting a display mode higher than the capability of the monitor. • The primary monitor cable is connected to the C2T device breakout cable. • You installed the necessary device drivers for the applications. 2. If you have verified these items and the screen remains blank, replace the monitor.

Note: See Chapter 7, "Parts listing Types 6223 and 6227," on page 115 to determine which components are replaceable by the customer (CRU), and which components must be replaced by a field service technician (FRU).

Monitor	
Symptom	FRU/action
The screen is wavy, unreadable, rolling, distorted, or has screen jitter.	<ol style="list-style-type: none"> If the monitor self-tests show the monitor is working properly, consider the location of the monitor. Magnetic fields around other devices (such as transformers, appliances, fluorescent lights, and other monitors) can cause screen jitter or wavy, unreadable, rolling, or distorted screen images. If this happens, turn off the monitor. (Moving a color monitor while it is turned on might cause screen discoloration.) Then move the device and the monitor at least 305 mm (12 in.) apart. Turn on the monitor. Notes: <ol style="list-style-type: none"> To prevent diskette drive read/write errors, make sure that the distance between monitors and diskette drives is at least 76 mm (3 in.). Non-IBM monitor cables might cause unpredictable problems. An enhanced monitor cable with additional shielding is available for the 9521 and 9527 monitors. For information about the enhanced monitor cable, contact your IBM reseller or IBM marketing representative. Video adapter, if installed. System board.
Wrong characters appear on the screen.	<ol style="list-style-type: none"> If the wrong language is displayed, update the BIOS code with the correct language. Video adapter, if installed. System board.
No video.	Make sure that all cables are connected correctly and securely. If you have installed a Remote Supervisor Adapter II in the computer, make sure that the video cable is connected to the Remote Supervisor Adapter II.

Note: See Chapter 7, "Parts listing Types 6223 and 6227," on page 115 to determine which components are replaceable by the customer (CRU), and which components must be replaced by a field service technician (FRU).

Option	
Symptom	FRU/action
An IBM option that was just installed does not work.	<ol style="list-style-type: none"> Verify that: <ul style="list-style-type: none"> The option is designed for the computer (see the ServerProven® list at http://www.ibm.com/pc/compat). You followed the installation instructions that came with the option. The option is installed correctly. You have not loosened any other installed options or cables. You updated the configuration information in the Configuration/Setup Utility program. Whenever memory or an option is changed, you must update the configuration. Option you just installed.

Note: See Chapter 7, “Parts listing Types 6223 and 6227,” on page 115 to determine which components are replaceable by the customer (CRU), and which components must be replaced by a field service technician (FRU).

Option	
Symptom	FRU/action
An IBM option that used to work does not work now.	<ol style="list-style-type: none"> 1. Verify that all of the option hardware and cable connections are secure. 2. If the option comes with its own test instructions, use those instructions to test the option. 3. If the failing option is a SCSI option, verify that: <ul style="list-style-type: none"> • The cables for all external SCSI options are connected correctly. • The last option in each SCSI chain, or the end of the SCSI cable, is terminated correctly. • Any external SCSI option is turned on. You must turn on an external SCSI option before turning on the computer. 4. Failing option.

Note: See Chapter 7, “Parts listing Types 6223 and 6227,” on page 115 to determine which components are replaceable by the customer (CRU), and which components must be replaced by a field service technician (FRU).

Power	
Symptom	FRU/action
The power switch does not work and the reset button, if supported, does work.	<ol style="list-style-type: none"> 1. Reseat the connector. 2. Power switch card. 3. System board.
The computer does not turn on.	<ol style="list-style-type: none"> 1. Verify that: <ul style="list-style-type: none"> • The power cables are properly connected to the computer. • The electrical outlet functions properly. • The type of memory installed is supported by the computer, and that functional DIMMs are installed in slots 1 and 2. • If you just installed an option, remove it, and restart the computer. If the computer now turns on, you might have installed more options than the power supply supports. 2. If LEDs for microprocessors or VRMs are on, verify that: <ol style="list-style-type: none"> a. A VRM is installed if a second microprocessor is present. b. All microprocessors have the same speed. 3. Check the power supply, see “Hot-swap power-supply LED errors” on page 103. If the power supply is operating correctly: <ol style="list-style-type: none"> a. Service processor (baseboard management controller) error. b. Operator information card. c. System board
The computer does not turn off.	<ol style="list-style-type: none"> 1. Verify whether you are using an ACPI or non-ACPI operating system. If you are using a non-ACPI operating system: <ol style="list-style-type: none"> a. Press Ctrl+Alt+Delete. b. Turn off the system by holding the power-control button for 4 seconds. c. If computer fails during BIOS POST and power-control button does not work, remove the AC power cord. 2. If the problem remains or if you are using an ACPI-aware operating system, suspect the system board.

Note: See Chapter 7, “Parts listing Types 6223 and 6227,” on page 115 to determine which components are replaceable by the customer (CRU), and which components must be replaced by a field service technician (FRU).

Serial port	
Symptom	FRU/action
The number of serial ports identified by the operating system is less than the number of serial ports installed.	<ol style="list-style-type: none"> 1. Verify that: <ul style="list-style-type: none"> • Each port is assigned a unique address by the Configuration/Setup Utility program and none of the serial ports is disabled. • The serial-port adapter, if you installed one, is seated properly. 2. Failing serial port adapter.
A serial device does not work.	<ol style="list-style-type: none"> 1. Verify that: <ul style="list-style-type: none"> • The device is compatible with the computer. • The serial port is enabled and is assigned a unique address. • The device is connected to the correct port (see “Input/output connectors” on page 53). 2. Failing serial device. 3. Serial adapter, if installed. 4. System board.

Note: See Chapter 7, “Parts listing Types 6223 and 6227,” on page 115 to determine which components are replaceable by the customer (CRU), and which components must be replaced by a field service technician (FRU).

ServerGuide Setup and Installation CD	
Symptom	FRU/action
The <i>ServerGuide Setup and Installation</i> CD will not start.	<ul style="list-style-type: none"> • Verify that the server is supported and has a startable (bootable) CD-ROM drive. • If the startup (boot) sequence settings have been altered, ensure that the CD-ROM drive is first in the startup sequence. • If more than one CD-ROM drive is installed, ensure that only one drive is set as the primary drive. Start the CD from the primary drive.
The SCSI RAID program cannot view all installed drives, or the NOS cannot be installed.	<ul style="list-style-type: none"> • Verify that there are no duplicate SCSI IDs or IRQ assignments. • Verify that the hard disk drive is connected properly.
The operating system installation program continuously loops.	<ul style="list-style-type: none"> • Make more space available on the hard disk.
The ServerGuide program will not start the operating-system CD.	<ul style="list-style-type: none"> • Verify that the operating-system CD you have is supported by the ServerGuide program. See the <i>ServerGuide Setup and Installation</i> CD label for a list of supported operating system versions.
The operating system cannot be installed; the option is not available.	<ul style="list-style-type: none"> • Verify that the operating system is supported on the computer. If the operating system is supported, either there is no logical drive defined (SCSI RAID systems) or the ServerGuide System Partition is not present. Run the ServerGuide program, and ensure that setup is complete.

Note: See Chapter 7, “Parts listing Types 6223 and 6227,” on page 115 to determine which components are replaceable by the customer (CRU), and which components must be replaced by a field service technician (FRU).

Software	
Symptom	FRU/action
Suspected software problem.	<ol style="list-style-type: none"> 1. To determine if problems are caused by the software, verify that: <ul style="list-style-type: none"> • The computer has the minimum memory needed to use the software. For memory requirements, see the information that comes with the software. Note: If you have just installed an adapter or memory, you might have a memory address conflict. • The software is designed to operate on the computer. • Other software works on the computer. • The software that you are using works on another system. <p>If you received any error messages when using the software program, see the information that comes with the software for a description of the messages and suggested solutions to the problem.</p> 2. If you have verified these items and the problem remains, contact the place of purchase.

Hot-swap power-supply LED errors

Use the information in this section to solve power-supply problems.

Note: The minimum configuration required for the dc good light to be lit is:

- Power supply
- Power cage assembly, if installed.
- System board.

Note: See “System replaceable units” on page 117 to determine which components should be replaced by a field service technician.

AC good LED	DC good LED	Description	FRU/action
Off	Off	No power to system or ac problem.	<ol style="list-style-type: none"> 1. Check ac power to the system. 2. Power supply.
On	Off	Standby mode or dc problem.	<ol style="list-style-type: none"> 1. Check system board cable connectors JPWR1 and JPWR2. Power-on the server. If the dc good LED is lit, press Ctrl+Alt+Delete. Watch the screen for any POST errors. Check the system error log for any listed problems. If the system starts with no errors: <ol style="list-style-type: none"> a. Power switch assembly b. System board 2. Remove the adapters and disconnect the cables and power connectors to all internal and external devices. Turn on the system. If the dc good LED is lit, replace the adapters and devices one at a time until you isolate the problem. 3. Power supply. 4. Power cage assembly, if installed. 5. System board.
On	On	Power is working properly.	N/A

Service processor error codes

When viewed in the system-error log, the Remote Supervisor Adapter II messages will appear as text descriptions. To determine a possible error condition for the Remote Supervisor Adapter II, see the system-error log (see “Starting the diagnostic programs and viewing the test log” on page 17).

SCSI error codes

Error code	FRU/action
<p>All SCSI Errors One or more of the following might be causing the problem:</p> <ul style="list-style-type: none">• A failing SCSI device (adapter, drive, controller)• An improper SCSI configuration or SCSI termination jumper setting• Duplicate SCSI IDs in the same SCSI chain• A missing or improperly installed SCSI terminator• A defective SCSI terminator• An improperly installed cable• A defective cable	<ol style="list-style-type: none">1. External SCSI devices must be turned on before you turn on the computer.2. Make sure that the cables for all external SCSI devices are connected correctly.3. If you have attached an external SCSI device to the computer, make sure the external SCSI termination is set to automatic.4. Make sure that the last device in each SCSI chain is terminated correctly.5. Make sure that the SCSI devices are configured correctly.

ServeRAID error codes

In the following error codes, x can be any number or letter.

Note: See “System replaceable units” on page 117 to determine which components should be replaced by a field service technician.	
Error code/symptom	FRU/action
1xxx (Microcode checksum error)	1. ServeRAID controller
2xxx (Code DRAM error)	1. Install download jumpers, flash latest level BIOS and firmware for controller. Remove jumpers. 2. ServeRAID controller.
3000-31xx(Code DRAM error)	1. Install download jumpers, flash latest level BIOS and firmware for controller. Remove jumpers. 2. ServeRAID controller.
3200 (Code DRAM error)	1. Install download jumpers, flash latest level BIOS code and firmware for controller. Remove jumpers. 2. ServeRAID controller.
3300 (ServeRAID-5i only)	1. Install ServeRAID-5i controller in an extended PCI expansion slot. See the documentation that came with the server for more information.
3E20 (ServeRAID-5i only)	1. Remove the ServeRAID-5i controller from its slot and install it in the proper PCI option slot. 2. Verify that the ServeRAID-5i controller is supported in this server. 3. ServeRAID-5i controller. 4. System board.
3E2x	1. Reseat the ServeRAID controller. 2. Flash latest level of BIOS code and firmware for controller. 3. ServeRAID-5i controller. 4. Integrated RAID controller on serve).
4xxx thru 5xxx (Code DRAM error)	1. Install download jumpers, flash latest level BIOS code and firmware for controller; then, remove jumpers. 2. ServeRAID controller.
6xxx (Cache DRAM error) (ServeRAID-4H only)	1. Reseat daughter card. 2. Install download jumpers, flash latest level BIOS code and firmware for controller; then, remove jumpers. 3. ServeRAID controller.
7xxx thru 8xxx (Host/local PCI bus interface error)	1. Flash latest level of BIOS code and firmware for controller. 2. If ServeRAID-4x controller, replace controller. 3. If ServeRAID-5i controller, integrated RAID controller on the computer.

Note: See “System replaceable units” on page 117 to determine which components should be replaced by a field service technician.

Error code/symptom	FRU/action
9003	<ol style="list-style-type: none"> 1. Flash latest level of BIOS code and firmware for controller. 2. Confirm that this controller is a supported option for this system. 3. ServeRAID controller. 4. Integrated RAID controller on the computer).
9xxx thru BZxx (SCSI bus error caused by cables, termination, defective drives, etc.). Z refers to the specific channel or channels that cause the error.	<ol style="list-style-type: none"> 1. Follow indications at “POST (ISPR) error procedures” on page 107. Follow those instructions before continuing with the next steps listed in this index. 2. SCSI cable. 3. SCSI backplane. 4. Hard disk drive. 5. ServeRAID controller.
EFFE (Firmware code corrupt or download jumpers are in place)	<ol style="list-style-type: none"> 1. Flash latest level BIOS and firmware for controller; then, remove jumpers. 2. ServeRAID controller.
FFFF or other code not listed	<ol style="list-style-type: none"> 1. Follow indications at “POST (ISPR) error procedures” on page 107. 2. SCSI cable. 3. SCSI backplane. 4. Hard disk drive. 5. ServeRAID controller.

POST (ISPR) error procedures

Use the ISPR error procedures to help you solve ServeRAID problems. A complete list of error codes is listed at "ServeRAID error codes" on page 105.

Note: Where the ISPR error procedures refer to a SCSI backplane, see the chapter of this publication that concerns service replaceable units.

EF10 (Default ISPR)

1. No ISPR error present.

9Zxx through BZxx (SCSI bus error caused by cables, termination, defective drives, or similar problem)

1. Isolate between SCSI subsystem and controller by disconnecting all SCSI cables from suspect card, and restart.

Attention: Do not press F5. Doing so changes the computer configuration.

If an ISPR error is still present, perform the following actions until the error is no longer present:

- a. Reseat the controller
- b. Replace the controller

Notes:

- a. SCSI channel cable details, if any, appear elsewhere in this publication.
 - b. The adapter/controller detects a configuration change. *Do not* select **Save Changes**. Instead, press F10 to bypass any options to this effect.
2. If ISPR error is **EF10** after disconnecting cables:
 - a. Identify which channel is causing the error by the second digit (Z) of the original ISPR code as indicated in the following table.

Note: ServeRAID-4H controllers have 4 channels; ServeRAID-4L and -4Lx controllers have only one channel; and ServeRAID-4M and -4Mx controllers have 2 channels. ServeRAID-5i and ServeRAID-6i controllers have no channels. The ServeRAID-5i and ServeRAID-6i use the channel connectors of the onboard integrated SCSI controller.

Table 4. SCSI identifier

SCSI Channel Code (z)	Descriptions
1	Channel 1
2	Channel 2
3	Channel 1 and 2
4	Channel 3
5	Channel 1 and 3
6	Channel 2 and 3
7	Channel 1, 2, and 3
8	Channel 4
9	Channel 1 and 4
A	Channel 2 and 4
B	Channel 1, 2, and 4
C	Channel 3 and 4

Table 4. SCSI identifier (continued)

SCSI Channel Code (z)	Descriptions
D	Channel 1, 3, and 4
E	Channel 2, 3, and 4
F	Channel 1, 2, 3, and 4

- b. Confirm that the channels identified from the error in step 2a on page 107 are the cause of the error by verifying that the error presents itself *only* when the offending channel is reconnected.
- c. Check termination of identified channel.

Note: SCSI channel termination details, if any, appear elsewhere in this publication.

- d. Check for proper backplane jumper configuration.

Note: SCSI channel jumper details, if any, appear elsewhere in this publication.

- e. Check for proper cabling configuration in systems that use hard disk drive status cables. Reconnect all cables removed in step 1 on page 107.
- f. Disconnect one drive at a time attached to the channel identified in step 2a on page 107; then, restart to determine which drive is causing the error.
- g. Replace SCSI cable.
- h. Replace SCSI backplane.

FFFF or other code not listed

1. Place download jumpers on the controller and try to flash the firmware code to the card.
2. Isolate between SCSI subsystem and controller by disconnecting all SCSI cables attached to the suspect card, and restart.

Attention: Do not press F5. Doing so changes the computer configuration. If ISPR code is **EF10** after disconnecting cables, follow these steps until the error is eliminated:

- a. Identify which channel is causing the error by reconnecting cables one at a time and restarting until the error returns.
- b. Check termination of identified channel in step 2a.

Note: SCSI channel termination details, if any, appear elsewhere in this publication.

- c. Disconnect one drive at a time attached to channel identified in step 2a and restart each time to determine which drive is causing the problem.
- d. Replace SCSI cable attached to channel identified in step 2a.
- e. Replace backplane attached to channel identified in step 2a.
3. If original ISPR code is still present after disconnecting all SCSI cables and restarting, perform the following actions until the error is no longer present:
 - Reseat the controller
 - Replace the controller

Temperature error messages

Note: See “System replaceable units” on page 117 to determine which components should be replaced by a field service technician.	
Message	Action
DASD Over Temperature (level-critical; direct access storage device bay x was over temperature)	<ul style="list-style-type: none"> • Ensure that the system is being properly cooled; see “System reliability considerations” on page 23.
DASD Over recommended Temperature (sensor x) (level-warning; DASD bay x had over temperature condition)	<ul style="list-style-type: none"> • Ensure that the system is being properly cooled; see “System reliability considerations” on page 23.
DASD under recommended temperature (sensor x) (level-warning; direct access storage device bay x had under temperature condition)	<ul style="list-style-type: none"> • Ambient temperature must be within normal operating specifications; see “Features and specifications” on page 3.
DASD Over Temperature (level-critical; sensor for DASD1 reported temperature over recommended range)	<ul style="list-style-type: none"> • Ensure that the system is being properly cooled; see “System reliability considerations” on page 23.
Power supply x Temperature Fault (level-critical; power supply x had over temperature condition)	<ol style="list-style-type: none"> 1. Ensure system is being properly cooled; see “System reliability considerations” on page 23. 2. Power supply x.
System board is over recommended temperature (level-warning; system board is over recommended temperature)	<ol style="list-style-type: none"> 1. Ensure system is being properly cooled; see “System reliability considerations” on page 23. 2. System board.
System board is under recommended temperature (level-warning; system board is under recommended temperature)	<ul style="list-style-type: none"> • Ambient temperature must be within normal operating specifications; see “Features and specifications” on page 3.
System over temperature for CPU x (level-warning; CPU x reporting over temperature condition)	<ul style="list-style-type: none"> • Ensure system is being properly cooled; see “System reliability considerations” on page 23.
System under recommended CPU x temperature (level-warning; system reporting under temperature condition for CPU x)	<ul style="list-style-type: none"> • Ambient temperature must be within normal operating specifications; see “Features and specifications” on page 3.

Fan error messages

Note: See “System replaceable units” on page 117 to determine which components should be replaced by a field service technician.	
Message	Action
Fan x failure (level-critical; fan x had a failure)	<ol style="list-style-type: none"> 1. Check connections to fan x. 2. Replace fan x.
Fan x fault (level-critical; fan x beyond recommended RPM range)	<ol style="list-style-type: none"> 1. Check connections to fan x. 2. Replace fan x.
Fan x outside recommended speed action	<ul style="list-style-type: none"> • Replace fan x.

Power error messages

Note: See “System replaceable units” on page 117 to determine which components should be replaced by a field service technician.	
Message	Action
Power supply x current share fault (level-critical; excessive current demand on power supply x)	<ul style="list-style-type: none"> • Replace power supply x.
Power supply x DC good fault (level-critical; power good signal not detected for power supply x)	<ul style="list-style-type: none"> • Replace power supply x.
Power supply x temperature fault	<ul style="list-style-type: none"> • Replace power supply x.
Power supply x removed	<ul style="list-style-type: none"> • No action required – information only.
Power supply x fan fault (level-critical; fan fault in power supply x)	<ul style="list-style-type: none"> • Replace power supply x.
Power supply x 12 V fault (level-critical; overcurrent condition detected)	<ul style="list-style-type: none"> • See “Power checkout” on page 22.
Power supply x 3.3 V fault (level-critical; 3.3 V power supply x had an error)	<ul style="list-style-type: none"> • See “Power checkout” on page 22.
Power supply x 5 V fault (level-critical; 5 V power supply x had an error)	<ul style="list-style-type: none"> • See “Power checkout” on page 22.
System running non-redundant power (level-noncritical; system does not have redundant power)	<ol style="list-style-type: none"> 1. Add another power supply. 2. Remove options from system. 3. System can continue to operate without redundancy protection if steps 1 and 2 are not followed.
System under recommended voltage for x (level-warning; indicated voltage supply under nominal value; value for x can be +12, -12, or +5)	<ol style="list-style-type: none"> 1. Check connections to the power subsystem. 2. Power supply. 3. Power cage assembly, if installed.

System shutdown

See the following tables when experiencing system shutdown related to voltage or temperature problems.

Voltage-related system shutdown

Note: See “System replaceable units” on page 117 to determine which components should be replaced by a field service technician.	
Message	Action
System shutoff due to x current over max value (level-critical; system drawing too much current on voltage x bus)	<ul style="list-style-type: none"> • See “Power checkout” on page 22.
System shutoff due to x V over voltage (level-critical; system shutoff due to x supply over voltage)	<ol style="list-style-type: none"> 1. Check the power-supply connectors. 2. Power supply. 3. Power cage assembly, if installed.

Note: See “System replaceable units” on page 117 to determine which components should be replaced by a field service technician.	
Message	Action
System shutoff due to x V under voltage (level-critical; system shutoff due to x supply under voltage)	<ol style="list-style-type: none"> 1. Check the power-supply connectors. 2. Power supply. 3. Power cage assembly, if installed.
System shutoff due to VRM x over voltage	<ul style="list-style-type: none"> • Replace VRM x.
System shutoff due to excessive (< 240 VA) loading	<ol style="list-style-type: none"> 1. See “Power checkout” on page 22. 2. Cycle ac on/off.

Temperature-related system shutdown

Note: See “System replaceable units” on page 117 to determine which components should be replaced by a field service technician.	
Message	Action
System shutoff due to board over temperature (level-critical; board is over temperature)	<ol style="list-style-type: none"> 1. Ensure that the system is being properly cooled; see “System reliability considerations” on page 23. 2. Replace board.
System shutoff due to CPU x over temperature (level-critical; CPU x is over temperature)	<ol style="list-style-type: none"> 1. Ensure that the system is being properly cooled; see “System reliability considerations” on page 23. 2. Replace microprocessor x.
System shutoff due to CPU x under temperature (level-critical; CPU x is under temperature)	<ul style="list-style-type: none"> • Ambient temperature must be within normal operating specifications; see “Features and specifications” on page 3.
System shutoff due to DASD temperature (sensor x) (level-critical; DASD area reported temperature outside recommended operating range)	<ul style="list-style-type: none"> • Ensure that the system is being properly cooled; see “System reliability considerations” on page 23.
System shutoff due to high ambient temperature (level-critical; high ambient temperature)	<ul style="list-style-type: none"> • Ambient temperature must be within normal operating specifications; see “Features and specifications” on page 3.
System shutoff due to system board under temperature (level-critical; system board is under temperature)	<ul style="list-style-type: none"> • Ambient temperature must be within normal operating specifications; see “Features and specifications” on page 3.

Hard disk drive checkout

Note: See “System replaceable units” on page 117 to determine which components should be replaced by a field service technician.	
Message	Action
Hard drive x removal detected (level-critical; hard drive x has been removed)	<ul style="list-style-type: none"> • Information only; take action as appropriate.

Host built-in self test (BIST)

Note: See “System replaceable units” on page 117 to determine which components should be replaced by a field service technician.

Message	Action
Host fail (level-informational; built-in self-test for the host failed)	<ol style="list-style-type: none"> 1. Reseat the microprocessor. 2. Replace the microprocessor.

Bus fault messages

Note: See “System replaceable units” on page 117 to determine which components should be replaced by a field service technician.

Bus fault messages	Message Action
Failure reading 12C device. Check devices on bus 0.	<ol style="list-style-type: none"> 1. If installed, reseat the I2C cable between RSA2 and the RSA2 connector on the system board. 2. DIMMs. 3. System board.
Failure reading 12C device. Check devices on bus 1.	<ol style="list-style-type: none"> 1. Reseat the I2C cable between the operator information panel and system board. 2. Operator information panel. 3. System board.
Failure reading 12C device. Check devices on bus 2.	<ol style="list-style-type: none"> 1. Reseat the cable between system board and the power supply (power cage assembly, if installed) (JPWR1, JPWR2). 2. Power cage assembly, if installed. 3. Power supply. 4. System board.
Failure reading 12C device. Check devices on bus 3.	<ol style="list-style-type: none"> 1. Reseat the cable between the SCSI backplane and connector on system board. 2. SCSI backplane. 3. System board.
Failure reading I2C device. Check device on bus 4.	<ul style="list-style-type: none"> • System board

Undetermined problems

Use the information in this section if the diagnostic tests did not identify the failure, the devices list is incorrect, or the system is inoperative.

Damaged data in CMOS memory or damaged BIOS code can cause undetermined problems. To reset the CMOS data, use the CMOS recovery jumper to override the power-on password and clear the CMOS memory; see “Erasing a lost or forgotten password (clearing CMOS)” on page 20. If you suspect that the BIOS code is damaged, see “Recovering from a POST/BIOS update failure” on page 19.

Check the LEDs on all the power supplies. If the LEDs indicate the power supplies are working correctly, complete the following steps:

1. Turn off the computer.
2. Be sure the computer is cabled correctly.
3. Remove or disconnect the following devices (one at a time) until you find the failure (turn on the computer and reconfigure each time):
 - Any external devices
 - Surge suppressor device (on the computer)
 - Modem, printer, mouse, or non-IBM devices
 - Each adapter
 - Drives
 - Memory modules (minimum requirement = 512 MB (2 banks of 256 MB DIMMs))

Note: Minimum operating requirements are:

- a. One power supply
 - b. Power cage assembly, if installed
 - c. System board
 - d. One microprocessor
 - e. Memory module (with a minimum of two 256 MB DIMMs)
4. Turn on the computer. If the problem remains, suspect the following FRUs in the order listed:
 - Power supply
 - Power cage assembly, if installed
 - System board

Notes:

1. If the problem goes away when you remove an adapter from the system and replacing that adapter does not correct the problem, suspect the system board.
2. If you suspect a networking problem and all the system tests pass, suspect a network cabling problem external to the system.

Problem determination tips

Because of the variety of hardware and software combinations that can be encountered, use the following information to assist you in problem determination. If possible, have this information available when requesting assistance from Service Support and Engineering functions.

- Machine type and model
- Microprocessor or hard disk upgrades
- Failure symptom
 - Do diagnostics fail?
 - What message appears in the diagnostics log?
 - What, when, where, single, or multiple systems?
 - Is the failure repeatable?
 - Has this configuration ever worked?
 - If it has been working, what changes were made prior to it failing?
 - Is this the original reported failure?
- Diagnostics version
 - Type and version level
- Hardware configuration
 - Print (print screen) configuration currently in use
 - BIOS level
- Operating system software
 - Type and version level

Note: To eliminate confusion, identical systems are considered identical only if they:

- Are the exact machine type and models
- Have the same BIOS level
- Have the same adapters/attachments in the same locations
- Have the same address jumpers/terminators/cabling
- Have the same software versions and levels
- Have the same diagnostics code (version)
- Have the same configuration options set in the system
- Have the same setup for the operation system control files

Comparing the configuration and software set-up between “working” and “non-working” systems will often lead to problem resolution.

Chapter 7. Parts listing Types 6223 and 6227

This parts listing supports the IntelliStation Z Pro Types 6223 and 6227. To check for an updated parts listing on the Web, complete the following steps:

1. Go to <http://www.ibm.com/support/>
2. Under **Search technical support**, type 6223 or 6227 and click **Search**.
3. Under Document type, select **Parts information** and click **Go**.

System

The major components of the IntelliStation Z Pro Types 6223 and 6227 are shown in the following illustration.

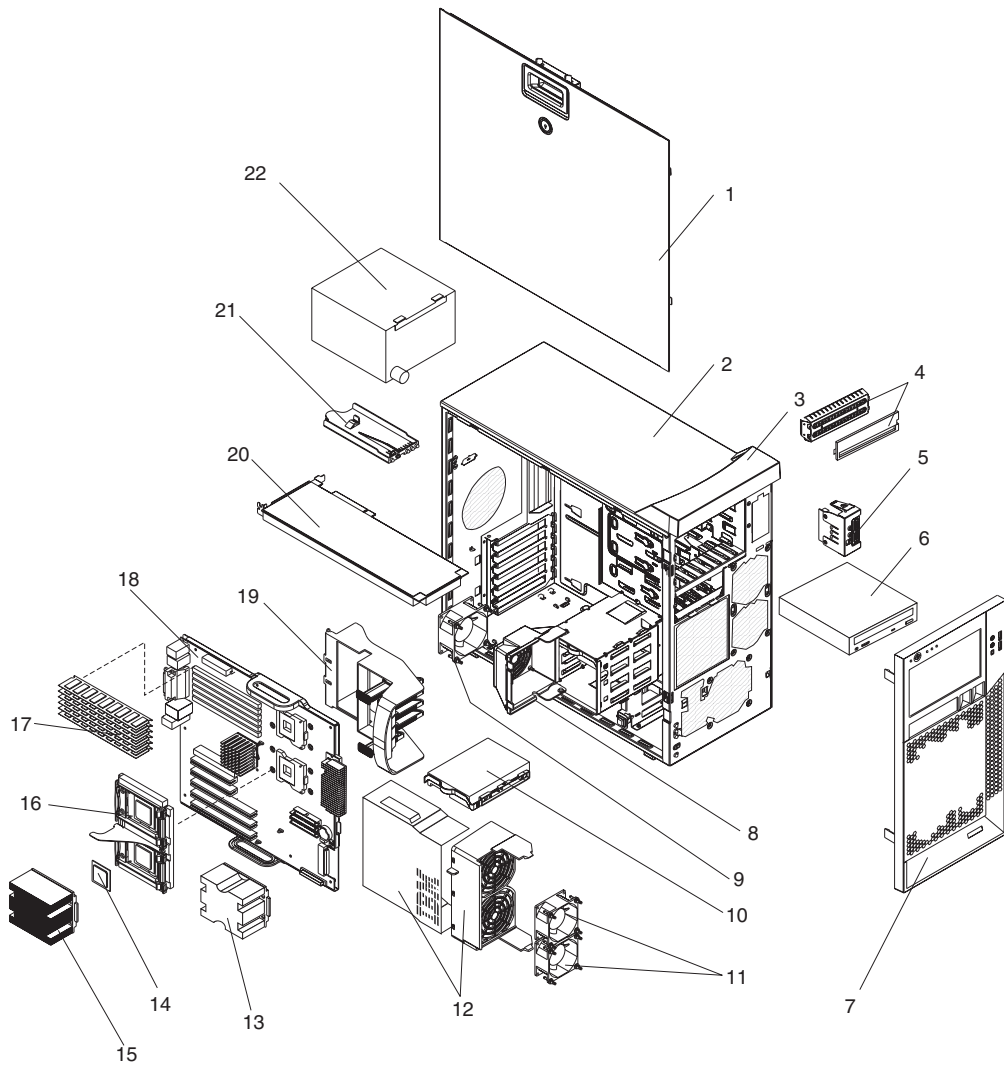

System replaceable units

Note:

- Field replaceable units (FRUs) must be serviced only by qualified field service technicians.
- Customer replaceable units (CRUs) can be replaced by the customer. Tier 1 CRUs and Tier 2 CRUs are described in the IBM "Statement of Limited Warranty" (at "Part 3 – Warranty Information"), which is in the *Installation Guide*.

Index	System IntelliStation Z Pro (Types 6223 and 6227)	CRU No. (Tier 1)	CRU No. (Tier 2)	FRU No.
1	Cover, side/top (all models)		13N2447	
2	Chassis, staked (all models)			13N2443
3	Handle cap assembly	13N2996		
4	Shield kit, 3.5" and 5.25" (all models)	13N2997		
5	Card, IEEE 1394 (FireWire) (all models)	39Y9700		
6	CD-ROM, 48x read/write (primary) (models 11x, 21x, 22x, 28x, 29x, B1x, B2x)	26K5376		
6	CD-ROM, 48X read/write (optional)	71P7347		
6	CD-ROM, 48X read/write (optional)	71P7349		
6	CD-ROM, half-high combo (primary) (models 12x, 14x, 23x, 24x, 26x, 27x, 2T6, 31x, 3Bx, 41x, 42x, 43x, 4Bx, 5Bx, 51x, 52x, 53x, 5Gx, 64x, 68x, 6Bx, 6Cx, 6Dx, 72x, 73x, 75x, 76x, 78x, 7Bx, 7Cx, 7Dx, 7Gx, 98x, B3x, B4x)	39M0135		
6	CD-ROM, half-high (alternate for 39M0135) (models 12x, 14x, 23x, 24x, 26x, 27x, 2T6, 31x, 3Bx, 41x, 42x, 43x, 4Bx, 5Bx, 51x, 52x, 53x, 5Gx, 64x, 68x, 6Bx, 6Cx, 6Dx, 72x, 73x, 75x, 76x, 78x, 7Bx, 7Cx, 7Dx, 7Gx, 98x, B3x, B4x)	26K5429		
6	DVD, 48X combo (alternate for 39M0135) (models 12x, 14x, 23x, 24x, 26x, 27x, 2T6, 31x, 3Bx, 41x, 42x, 43x, 4Bx, 5Bx, 51x, 52x, 53x, 5Gx, 64x, 68x, 6Bx, 6Cx, 6Dx, 72x, 73x, 75x, 76x, 78x, 7Bx, 7Cx, 7Dx, 7Gx, 98x, B3x, B4x)	26K5379		
6	DVD, 48X combo (optional)	26K5381		
6	CD-ROM, 48X (optional)	71P7375		
6	CD-ROM, 48X (optional)	71P7385		
6	CD-ROM, 16/48X (optional)	26K5435		
6	CD-ROM, 48X half high, read/write (models 11x, 21x, 22x, 28x, 29x, B1x, B2x, 11x)	26K5449		
6	DVD, half high ()	39M3515		
6	CD-ROM, 48X half high, read/write (models 10x, 3Gx, 6Gx, 98x, 99x, A0x)	39M3511		
6	CD-ROM, 48X half high (primary) (models 10x, 3Gx, 6Gx, 98x, 99x, A0x)	42C0953		
6	CD-ROM, 48X half high (alternate for 42C0953) (models 10x, 3Gx, 6Gx, 98x, 99x, A0x)	39M3509		
7	Bezel, front (all models)	13N2445		
8	Pivoting duct/fan assembly, DASD cage (all models)	13N2995		
9	Fan assembly, 92X38 (all models except 3Bx, 4Bx, 5Bx, 5Cx, 6Bx, 6Cx, 6Dx, 7Bx, 7Cx, 7Dx)			13N2967

Index	System IntelliStation Z Pro (Types 6223 and 6227)	CRU No. (Tier 1)	CRU No. (Tier 2)	FRU No.
9	Fan assembly, 92X38 (models 3Bx, 4Bx, 5Bx, 5Cx, 6Bx, 6Cx, 6Dx, 7Bx, 7Cx, 7Dx)			39Y9788
10	Hard disk drive, 80GB (models 10x, 11x, 12x, 21x, 23x, 31x, 41x, 43x, 51x, 53x, 72x, 73x, 75x, 98x, A0x, B1x, B3x)	71P7293		
10	Hard disk drive, 73.4GB SCSI 10K RPM model 14x, 22x, 24x, 26x, 27x, 28x, 29x, 42x, 52x, 64x, 68x, 76x, 78x, B2x, B4x)	24P3706		
10	Hard disk drive, 36.4GB SCSI 10K RPM (model 99x)	24P3704		
10	Hard disk drive, 36.4GB 15K NHS (model CTO)	39R7326		
10	Hard disk drive, 160GB SCSI 10K RPM (models 3Bx, 4Bx, 5Bx, 5Gx, 6Bx, 7Bx, 7Gx)	39M4507		
10	Hard disk drive, 160GB SATA (models AC1, MC1, CTO)	40K6871		
10	Hard disk drive, 146.8 SCSI 10K RPM (optional)	24P3708		
10	Hard disk drive, 36.4GB SCSI 15K RPM (optional)	24P3725		
10	Hard disk drive, 73GB (model 7Dx)	39R7328		
10	Hard disk drive, 73GB 15K NHS (models 5Cx, 6Cx, 6Dx, 7Cx)	39R7320		
10	Hard disk drive, 73.4GB SCSI 15K RPM (optional)	24P3727		
10	Hard disk drive, 146GB 15K NHS (model CTO)	39R7322		
10	Hard disk drive, 146GB 15K NHS (models AC1, MC1, CTO)	39R7330		
10	Hard disk drive, 146GB 10K NHS (model CTO)	39R7324		
11	Fan assembly, 80X38, S/R (models 12x, 26x, 27x, 31x, 41x, 42x, 43x, 51x, 52x, 53x, 64x, 68x, 72x, 76x, 78x)			25R8830
11	Fan assembly, 80X38, S/R (models 3Bx, 4Bx, 5Bx, 5Cx, 6Bx, 6Cx, 6Dx, 7Bx, 7Cx, 7Dx)			39Y9786
11	Fan assembly, 80X38, S/R (models 3Bx, 4Bx, 5Bx, 5Cx, 6Bx, 6Cx, 6Dx, 7Bx, 7Cx, 7Dx)			39Y9787
11	Fan assembly, 80X38, S/R (all models except 12x, 26x, 27x, 31x, 41x, 42x, 43x, 51x, 52x, 53x, 64x, 68x, 72x, 76x, 78x)			13N2966
12	Air duct, microprocessor (all models)	13N2448		
13	Dummy heat sink assembly (models 01x, 10x, 11x, 12x, 21x, 22x, 23x, 24x, 28x, 26x, 27x, 29x, 31x, 41x, 42x, 43x, 51x, 52x, 53x, 64x, 68x, 72x, 75x, 76x, 78x, 75x, 98x, 99x, B1x, B2x, B3x, A0x)	26K6065		
13	Dummy heat sink assembly (models 3Bx, 4Bx, 5Bx, 6Bx, 6Cx, 6Dx, 7Bx, 7Cx, 7Dx)	40K6482		
14	Microprocessor, 800/3.4MHz 1MB (models 10x, 11x, 12x, 14x, 98x, 99x, A0x)			90P1227
14	Microprocessor, 800/3.6MHz-1M (models 21x, 22x, 23x, 24x, 26x, 27x, 28x, 29x, 2T6, B1x, B2x, B3x, B4x)			90P1229
14	Microprocessor, 800/3.0MHz-2M (models 31x, 3Bx)			13M8293
14	Microprocessor, 800/3.2MHz-2M (models 41x, 42x, 43x, 4Bx)			13M8294
14	Microprocessor, 800/3.4MHz-2M (models 51x, 52x, 53x, 5Bx, 5Cx)			13M8295
14	Microprocessor, 800/3.6MHz-2M (models 64x, 68x, 6Bx, 6Cx)			13M8296
14	Microprocessor, 800/3.8MHz-2M (models 72x, 73x, 75x, 76x, 78x)			39R7571

Index	System IntelliStation Z Pro (Types 6223 and 6227)	CRU No. (Tier 1)	CRU No. (Tier 2)	FRU No.
15	Heat sink (models 01x, 11x, 12x, 21x, 31x, 41x, 43x, 51x, 53x, 72x, 75x, 98x, 99x, A0x, B1x, B2x, B3x)			13N1625
15	Heat sink (models 12x, 26x, 27x, 31x, 41x, 42x, 43x, 51x, 52x, 53x, 64x, 68x, 72x, 76x, 78x)			25R8832
16	Tool-less retention module assembly, left (all models)			26K6146
16	Tool-less retention module assembly, right (all models)			26K6147
17	Memory, 256MB ECC DDR II 400 (models 10x, 98x, 99x, A0x)	90P1123		
17	Memory, 1GB ECC DDR II 400 (models 27x, 43x, 51x, 53x, 64x, 68x, 72x, 73x, 75x, 76x, 78x)	73P2870		
17	Memory DIMM, 512MB PC2-3200 DIMM (models 21x, 22x, 23x, 24x, 28x, 29x, 11x, 14x, 12x, 26x, 31x, 41x, 42x, 52x, 3Gx, 6Gx, B1x, B2x, B3x ,B4x)	13N1424		
17	Memory DIMM, 512MB PC2-3200 (model 3Bx)	39M5817		
17	Memory DIMM, 1GB PC2-3200 (models 27x, 43x, 4Bx, 51x, 53x, 5Bx, 5Cx, 5Gx, 64x, 68x, 6Bx, 6Cx, 6Dx, 72x, 73x, 72x, 73x, 75x, 76x, 78x, 7Bx, 7Cx, 7Dx, 7Gx)	39M5808		
17	Memory DIMM, 1GB PC2-3200 (models AC1, MC1, CTO)	39M5811		
17	Memory 4GB PC2-3200 (optional)	41Y2815		
18	System board and tray assembly (all models)			26K8598
18	System board and tray assembly (models 3Bx, 4Bx, 5Bx, 5Cx, 6Bx, 6Cx, 6Dx, 7Bx, 7Cx, 7Dx)			39Y8575
19	Card guide assembly (all models)		13N2993	
20	Card, 3DLabs Realizm 800 (models 27x, 52x, 68x, 78x)	73P9640		
20	Card, NVIDIA PCI (models 10x, 11x, 31x, 41x, 75x, 98x, 99x, A0x)	90P1057		
20	Card, NVIDIA Q FX1300 (models 21x, 22x, 28x, B1x, B2x)	90P1058		
20	Card, NVIDIA Q FX1400 (models 12x, 42x, 43x, 51x, 53x, 72x)	73P9636		
20	Card, NVIDIA Q FX3400 (models 14x, 23x, 24x, 29x, B3x, B4x)	90P1175		
20	Card, NVIDIA Q FX 4400 (model 2T6)	13M8405		
20	Card, FX 1400 Nvidia (models 3Bx, 5Bx, 6Cx, 6Dx)	13M8415		
20	Card, FX 4500 Nvidia (model 7Dx)	13M8429		
20	Card, NVS, 285 (models 4Bx, 6Bx)	13M8433		
20	Card, FX 3500 Video (models 5Bx, 7Bx, 7Cx)	13M8457		
21	Control panel, power/LED (all models)	39Y9792		
21	Control panel, power/LED (all models)	39Y9792		
22	Power supply, 530 watt (models 12x, 26x, 27x, 31x, 41x, 42x, 43x, 51x, 52x, 53x, 64x, 68x, 72x, 76x, 78x)			24R2670
22	Power supply, 530 watt (all models except 12x, 26x, 27x, 31x, 41x, 42x, 43x, 51x, 52x, 53x, 64x, 68x, 72x, 76x, 78x)			24R2660
22	Power supply, 530 watt (all models except 01x, 10x, 11x, 12x, 21x, 22x, 23x, 24x, 28x, 26x, 27x, 29x, 31x, 41x, 42x, 43x, 51x, 52x, 53x, 64x, 68x, 72x, 75x, 76x, 78x, 98x, 99x, A0x, B1x, B2x, B3x)			39Y7279
22	Power supply, 530 watt (models 3Bx, 4Bx, 5Bx, 5Cx, 6Bx, 6Cx, 6Dx, 7Bx, 7Cx, 7Dx)			39Y7277

Index	System IntelliStation Z Pro (Types 6223 and 6227)	CRU No. (Tier 1)	CRU No. (Tier 2)	FRU No.
	Access panel assembly, pivoting with latch and lock (raven black) (all models)	13N2444		
	Baffle, air (models 12x, 26xm 27x, 31x, 41x, 42x, 43x, 51x, 52x, 53x, 64x, 68x, 72x, 76x, 78x)	25R8833		
	Battery, 3 volt (all models)		33F8354	
	C2 switch with cable (all models)	09K9827		
	C2 switch with cable (models 3Bx, 4Bx, 5Bx, 5Cx, 6Bx, 6Cx, 6Dx, 7Bx, 7Cx, 7Dx)	39Y9783		
	Cable, diskette drive (all models)		39Y9728	
	Cable, DVI pigtail (optional)		73P9600	
	Cable, IDE (all models)		13N2466	
	Cable, audio (all models)		13N2999	
	Cable, audio (models 3Bx, 4Bx, 5Bx, 5Cx, 6Bx, 6Cx, 6Dx, 7Bx, 7Cx, 7Dx)		39Y9789	
	Cable, dual VGA (models 10x, 11x, 31x, 41x, 75x, 4Bx, 6Bx, 5Gx, 7Gx, 98x, 99x, A0x)		25R9045	
	Cable, DVI (models AC1, MC1, CTO)		25R9048	
	Cable, USB 2.0 (all models)		26K6096	
	Cable, USB 2.0 (models 3Bx, 4Bx, 5Bx, 5Cx, 6Bx, 6Cx, 6Dx, 7Bx, 7Cx, 7Dx)		39Y9790	
	Cable, FireWire (all models)		26K7302	
	Cable, FireWire (models 3Bx, 4Bx, 5Bx, 5Cx, 6Bx, 6Cx, 6Dx, 7Bx, 7Cx, 7Dx)		39Y9791	
	Cable, SCSI, U320, 4 drop (models 14x, 22x, 24x, 28x, 29x, 26x, 27x, 2T6, 42x, 52x, 5Cx, 64x, 68x, 6Cx, 76x, 78x, 7Cx, 7Dx, 99x, B2x, B4x)		39Y9785	
	Cable, SCSI, U320, 4 drop (models 14x, 22x, 24x, 26x, ,27x, 28x, 29x, 2T6, 42x, 52x, 5Cx, 64x, 68x, 6Cx, 7Cx, 7Dx, 76x, 78x, 99x, B2x, B4x)		39Y9785	
	Cable, SATA (models 11x, 12x, 21x, 23x, 10x, 31x, 41x, 43x, 51x, 53x, 5Gx, 3Bx, 4Bx, 5Bx, 6Bx, 72x, 73x, 75x, 7Bx, 7Gx, 98x, B1x, B3x, CBx, DBx, FBx, JBx, KBx)		39Y9810	
	Card, ATI FireGL V7100 (models 26x, 64x, 73x, 76x)	13M8400		
	Dongle (all models except 10x, 11x, 98x, 99x, A0x)			25R9043
	Diskette drive (all models)	39M0101		
	FRU kit, bezel blanks (all models)	13N2450		
	FRU kit, feet (all models)	13N2985		
	Hardware kit, miscellaneous items (all models)		39Y9773	
	Hardware kit, miscellaneous items (all models)		09N5764	
	I/O card retainer (all models)	13N2994		
	Keylock, alike (models AC1, MC1, CTO)			26K7363
	Keylock, random (all models)			26K7364
	Line cord (all models except 01x, 10x, 11x, 12x, 21x, 22x, 23x, 24x, 28x, 26x, 27x, 29x, 31x, 41x, 42x, 43x, 51x, 52x, 53x, 64x, 68x, 72x, 75x, 76x, 78x, 98x, 99x, A0x, B1x, B2x, B3x)	39M5095		

Index	System IntelliStation Z Pro (Types 6223 and 6227)	CRU No. (Tier 1)	CRU No. (Tier 2)	FRU No.
	Mouse (all models)	39Y9876		
	Pivoting DASD cage assembly (all models)			26K7303
	Power button shield (all models)		71P8467	
	Power supply VRM, 2U/105A (models 27x, 29x, 43x, 52x, 53x, 64x, 68x, 76x, 78x)		24R2702	
	Power supply VRM, 2U/105A (models 5Cx, 6Dx, 7Dx)		39Y7260	
	Power cord, see "Power cords (CRUs)" on page 122.	93F2364		
	Retainer (all models)	13N2449		
	Speaker assembly (all models)		19K4929	
	Speaker assembly (models 3Bx, 4Bx, 5Bx, 5Cx, 6Bx, 6Cx, 6Dx, 7Bx, 7Cx, 7Dx)		39Y9720	
	Service label (all models)	26K7304		
	Tool-less DASD tray assembly with dampening pads (all models)	26K7320		

Recovery CD (Windows XP)

Recovery CD	CRU No.
English, Windows XPP 32 bit (EN)	42D2388
French, Windows XPP 32 bit (EN)	42D2389
German, Windows XPP 32 bit (GE)	42D2390
Italian, Windows XPP 32 bit (IT)	42D2391
Spanish, Windows XPP 32 bit (SP)	42D2392
Norwegian, Windows XPP 32 bit (NO)	42D2395
Dutch, Windows XPP 32 bit (NL)	42D2394
Danish, Windows XPP 32 bit (DK)	42D2393
Swedish, Windows XPP 32 bit (SV)	42D2396
Finnish, Windows XPP 32 bit (FI)	42D2397
Korean, Windows XPP 32 bit (KR)	42D2399
Japanese, Windows XPP 32 bit (JP)	42D2398
Chinese, Windows XPP 32 bit (CS)	42D2400
Chinese, Hong Kong, Windows XPP 32 bit (HK)	42D2401
Chinese, Traditional, Windows XPP 32 bit (CT)	42D2402

Keyboards (CRUs)

Keyboard	CRU No.
US English	39M6989
Arabic (523)	39M6990
Arabic/French (462)	39M6991
Belgium/French (120)	39M6992
Belgium/UK (120)	39M6993
Brazil/Portuguese (275)	39M6994
Bulgarian (442)	39M6995
Chinese/US (467)	39M6996
Czech ABB	39M6997
Danish (159)	39M6998

Keyboard	CRU No.
Dutch (143)	39M6999
French (189)	39M7000
French Canadian (445)	39M7001
French Canadian (058)	39M7002
German (129)	39M7003
Greek (319)	39M7004
Hebrew (212)	39M7005
Hungarian (208)	39M7006
Iceland (197)	39M7007
Italy (141)	39M7008
Italy (142)	39M7009
Japanese (194)	39M7010
Korean (413)	39M7011
LA Spanish (171)	39M7012
Norwegian (155)	39M7013
Polish (214)	39M7014
Portuguese (163)	39M7015
Romanian (96)	39M7016
Russian (443)	39M7017
Russian/Cyrillic (441)	39M7018
Serbian/Cyrillic (118)	39M7019
Slavic (245)	39M7020
Slovenian (234)	39M7029
Spanish (172)	39M7021
Swedish/Finn (153)	39M7022
Swiss, French/German (150)	39M7023
Thailand (191)	39M7024
Turkish (440)	39M7025
Turkish (179)	39M7026
UK English (166)	39M7027
US English-EMEA (103p)	39M7028

Power cords (CRUs)

For your safety, IBM provides a power cord with a grounded attachment plug to use with this IBM product. To avoid electrical shock, always use the power cord and plug with a properly grounded outlet.

IBM power cords used in the United States and Canada are listed by Underwriter's Laboratories (UL) and certified by the Canadian Standards Association (CSA).

For units intended to be operated at 115 volts: Use a UL-listed and CSA-certified cord set consisting of a minimum 18 AWG, Type SVT or SJT, three-conductor cord, a maximum of 15 feet in length and a parallel blade, grounding-type attachment plug rated 15 amperes, 125 volts.

For units intended to be operated at 230 volts (U.S. use): Use a UL-listed and CSA-certified cord set consisting of a minimum 18 AWG, Type SVT or SJT, three-conductor cord, a maximum of 15 feet in length and a tandem blade, grounding-type attachment plug rated 15 amperes, 250 volts.

For units intended to be operated at 230 volts (outside the U.S.): Use a cord set with a grounding-type attachment plug. The cord set should have the appropriate safety approvals for the country in which the equipment will be installed.

IBM power cords for a specific country or region are usually available only in that country or region.

IBM power cord part number	Used in these countries and regions
02K0546	China
13F9940	Australia, Fiji, Kiribati, Nauru, New Zealand, Papua New Guinea
13F9979	Afghanistan, Albania, Algeria, Andorra, Angola, Armenia, Austria, Azerbaijan, Belarus, Belgium, Benin, Bosnia and Herzegovina, Bulgaria, Burkina Faso, Burundi, Cambodia, Cameroon, Cape Verde, Central African Republic, Chad, Comoros, Congo (Democratic Republic of), Congo (Republic of), Cote D'Ivoire (Ivory Coast), Croatia (Republic of), Czech Republic, Dahomey, Djibouti, Egypt, Equatorial Guinea, Eritrea, Estonia, Ethiopia, Finland, France, French Guyana, French Polynesia, Germany, Greece, Guadeloupe, Guinea, Guinea Bissau, Hungary, Iceland, Indonesia, Iran, Kazakhstan, Kyrgyzstan, Laos (People's Democratic Republic of), Latvia, Lebanon, Lithuania, Luxembourg, Macedonia (former Yugoslav Republic of), Madagascar, Mali, Martinique, Mauritania, Mauritius, Mayotte, Moldova (Republic of), Monaco, Mongolia, Morocco, Mozambique, Netherlands, New Caledonia, Niger, Norway, Poland, Portugal, Reunion, Romania, Russian Federation, Rwanda, Sao Tome and Principe, Saudi Arabia, Senegal, Serbia, Slovakia, Slovenia (Republic of), Somalia, Spain, Suriname, Sweden, Syrian Arab Republic, Tajikistan, Tahiti, Togo, Tunisia, Turkey, Turkmenistan, Ukraine, Upper Volta, Uzbekistan, Vanuatu, Vietnam, Wallis and Futuna, Yugoslavia (Federal Republic of), Zaire
13F9997	Denmark
14F0015	Bangladesh, Lesotho, Maceo, Maldives, Namibia, Nepal, Pakistan, Samoa, South Africa, Sri Lanka, Swaziland, Uganda
14F0033	Abu Dhabi, Bahrain, Botswana, Brunei Darussalam, Channel Islands, China (Hong Kong S.A.R.), Cyprus, Dominica, Gambia, Ghana, Grenada, Iraq, Ireland, Jordan, Kenya, Kuwait, Liberia, Malawi, Malaysia, Malta, Myanmar (Burma), Nigeria, Oman, Polynesia, Qatar, Saint Kitts and Nevis, Saint Lucia, Saint Vincent and the Grenadines, Seychelles, Sierra Leone, Singapore, Sudan, Tanzania (United Republic of), Trinidad and Tobago, United Arab Emirates (Dubai), United Kingdom, Yemen, Zambia, Zimbabwe
14F0051	Liechtenstein, Switzerland
14F0069	Chile, Italy, Libyan Arab Jamahiriya
14F0087	Israel
1838574	Antigua and Barbuda, Aruba, Bahamas, Barbados, Belize, Bermuda, Bolivia, Brazil, Caicos Islands, Canada, Cayman Islands, Costa Rica, Colombia, Cuba, Dominican Republic, Ecuador, El Salvador, Guam, Guatemala, Haiti, Honduras, Jamaica, Japan, Mexico, Micronesia (Federal States of), Netherlands Antilles, Nicaragua, Panama, Peru, Philippines, Taiwan, United States of America, Venezuela
24P6858	Korea (Democratic People's Republic of), Korea (Republic of)
34G0232	Japan
36L8880	Argentina, Paraguay, Uruguay
49P2078	India
49P2110	Brazil
93F2364	Antigua and Barbuda, Aruba, Bahamas, Barbados, Belize, Bermuda, Bolivia, Caicos Islands, Canada, Cayman Islands, Colombia, Costa Rica, Cuba, Dominican Republic, Ecuador, El Salvador, Guam, Guatemala, Haiti, Honduras, Jamaica, Mexico, Micronesia (Federal States of), Netherlands Antilles, Nicaragua, Panama, Peru, Philippines, Saudi Arabia, Thailand, Taiwan, United States of America, Venezuela

Appendix A. Getting help and technical assistance

If you need help, service, or technical assistance or just want more information about IBM products, you will find a wide variety of sources available from IBM to assist you. This appendix contains information about where to go for additional information about IBM and IBM products, what to do if you experience a problem with your xSeries or IntelliStation system, and whom to call for service, if it is necessary.

Before you call

Before you call, make sure that you have taken these steps to try to solve the problem yourself:

- Check all cables to make sure that they are connected.
- Check the power switches to make sure that the system is turned on.
- Use the troubleshooting information in your system documentation, and use the diagnostic tools that come with your system. Information about diagnostic tools is in the *Hardware Maintenance Manual and Troubleshooting Guide* on the IBM *xSeries Documentation* CD or in the *IntelliStation Hardware Maintenance Manual* at the IBM Support Web site.
- Go to the IBM Support Web site at <http://www.ibm.com/support> to check for technical information, hints, tips, and new device drivers or to submit a request for information.

You can solve many problems without outside assistance by following the troubleshooting procedures that IBM provides in the online help or in the publications that are provided with your system and software. The information that comes with your system also describes the diagnostic tests that you can perform. Most xSeries and IntelliStation systems, operating systems, and programs come with information that contains troubleshooting procedures and explanations of error messages and error codes. If you suspect a software problem, see the information for the operating system or program.

Using the documentation

Information about your IBM xSeries or IntelliStation system and preinstalled software, if any, is available in the documentation that comes with your system. That documentation includes printed books, online books, README files, and help files. See the troubleshooting information in your system documentation for instructions for using the diagnostic programs. The troubleshooting information or the diagnostic programs might tell you that you need additional or updated device drivers or other software. IBM maintains pages on the World Wide Web where you can get the latest technical information and download device drivers and updates. To access these pages, go to <http://www.ibm.com/support> and follow the instructions. Also, you can order publications through the IBM Publications Ordering System at <http://www.elink.ibm.com/public/applications/publications/cgibin/pbi.cgi>.

Getting help and information from the World Wide Web

On the World Wide Web, the IBM Web site has up-to-date information about IBM xSeries and IntelliStation products, services, and support. The address for IBM xSeries information is <http://www.ibm.com/eserver/xseries/>. The address for IBM IntelliStation information is <http://www.ibm.com/pc/intellistation/>.

You can find service information for your IBM products, including supported options, at <http://www.ibm.com/support>.

Software service and support

Through IBM Support Line, you can get telephone assistance, for a fee, with usage, configuration, and software problems with xSeries servers, IntelliStation workstations, and appliances. For information about which products are supported by Support Line in your country or region, go to <http://www.ibm.com/services/sl/products/>.

For more information about Support Line and other IBM services, go to <http://www.ibm.com/services/>, or go to <http://www.ibm.com/planetwide/> for support telephone numbers. In the U.S. and Canada, call 1-800-IBM-SERV (1-800-426-7378).

Hardware service and support

You can receive hardware service through IBM Integrated Technology Services or through your IBM reseller, if your reseller is authorized by IBM to provide warranty service. Go to <http://www.ibm.com/planetwide/> for support telephone numbers, or in the U.S. and Canada, call 1-800-IBM-SERV (1-800-426-7378).

In the U.S. and Canada, hardware service and support is available 24 hours a day, 7 days a week. In the U.K., these services are available Monday through Friday, from 9 a.m. to 6 p.m.

Appendix B. Safety information

Note: The service procedures are designed to help you isolate problems. They are written with the assumption that you have model-specific training on all computers, or that are familiar with the computers, functions, terminology, and service information provided in this manual.

The following section contains the safety information that you need to be familiar with before servicing an IBM computer.

General safety

Follow these rules to ensure general safety:

- Observe good housekeeping in the area of the machines during and after maintenance.
- When lifting any heavy object:
 1. Ensure you can stand safely without slipping.
 2. Distribute the weight of the object equally between your feet.
 3. Use a slow lifting force. Never move suddenly or twist when you attempt to lift.
 4. Lift by standing or by pushing up with your leg muscles; this action removes the strain from the muscles in your back. *Do not attempt to lift any objects that weigh more than 16 kg (35 lb) or objects that you think are too heavy for you.*
- Do not perform any action that causes hazards to the customer, or that makes the equipment unsafe.
- Before you start the machine, ensure that other service representatives and the customer's personnel are not in a hazardous position.
- Place removed covers and other parts in a safe place, away from all personnel, while you are servicing the machine.
- Keep your tool case away from walk areas so that other people will not trip over it.
- Do not wear loose clothing that can be trapped in the moving parts of a machine. Ensure that your sleeves are fastened or rolled up above your elbows. If your hair is long, fasten it.
- Insert the ends of your necktie or scarf inside clothing or fasten it with a nonconductive clip, approximately 8 centimeters (3 inches) from the end.
- Do not wear jewelry, chains, metal-frame eyeglasses, or metal fasteners for your clothing.

Remember: Metal objects are good electrical conductors.
- Wear safety glasses when you are: hammering, drilling soldering, cutting wire, attaching springs, using solvents, or working in any other conditions that might be hazardous to your eyes.
- After service, reinstall all safety shields, guards, labels, and ground wires. Replace any safety device that is worn or defective.
- Reinstall all covers correctly before returning the machine to the customer.

Electrical safety



CAUTION:

Electrical current from power, telephone, and communication cables can be hazardous. To avoid personal injury or equipment damage, disconnect the attached power cords, telecommunication systems, networks, and modems before you open the server covers, unless instructed otherwise in the installation and configuration procedures.

Observe the following rules when working on electrical equipment.

Important: Use only approved tools and test equipment. Some hand tools have handles covered with a soft material that does not insulate you when working with live electrical currents.

Many customers have, near their equipment, rubber floor mats that contain small conductive fibers to decrease electrostatic discharges. Do not use this type of mat to protect yourself from electrical shock.

- Find the room emergency power-off (EPO) switch, disconnecting switch, or electrical outlet. If an electrical accident occurs, you can then operate the switch or unplug the power cord quickly.
- Do not work alone under hazardous conditions or near equipment that has hazardous voltages.
- Disconnect all power before:
 - Performing a mechanical inspection
 - Working near power supplies
 - Removing or installing main units
- Before you start to work on the machine, unplug the power cord. If you cannot unplug it, ask the customer to power-off the wall box that supplies power to the machine and to lock the wall box in the off position.
- If you need to work on a machine that has exposed electrical circuits, observe the following precautions:
 - Ensure that another person, familiar with the power-off controls, is near you.
Remember: Another person must be there to switch off the power, if necessary.
 - Use only one hand when working with powered-on electrical equipment; keep the other hand in your pocket or behind your back.
Remember: There must be a complete circuit to cause electrical shock. By observing the above rule, you may prevent a current from passing through your body.
 - When using testers, set the controls correctly and use the approved probe leads and accessories for that tester.
 - Stand on suitable rubber mats (obtained locally, if necessary) to insulate you from grounds such as metal floor strips and machine frames.

Observe the special safety precautions when you work with very high voltages; these instructions are in the safety sections of maintenance information. Use extreme care when measuring high voltages.

- Regularly inspect and maintain your electrical hand tools for safe operational condition.

- Do not use worn or broken tools and testers.
- *Never assume* that power has been disconnected from a circuit. First, *check* that it has been powered-off.
- Always look carefully for possible hazards in your work area. Examples of these hazards are moist floors, nongrounded power extension cables, power surges, and missing safety grounds.
- Do not touch live electrical circuits with the reflective surface of a plastic dental mirror. The surface is conductive; such touching can cause personal injury and machine damage.
- Do not service the following parts with the power on when they are removed from their normal operating places in a machine:
 - Power supply units
 - Pumps
 - Blowers and fans
 - Motor generators
 and similar units. (This practice ensures correct grounding of the units.)
- If an electrical accident occurs:
 - Use caution; do not become a victim yourself.
 - Switch off power.
 - Send another person to get medical aid.

Safety inspection guide

The intent of this inspection guide is to assist you in identifying potentially unsafe conditions on these products. Each machine, as it was designed and built, had required safety items installed to protect users and service personnel from injury. This guide addresses only those items. However, good judgment should be used to identify potential safety hazards due to attachment of non-IBM features or options not covered by this inspection guide.

If any unsafe conditions are present, you must determine how serious the apparent hazard could be and whether you can continue without first correcting the problem.

Consider these conditions and the safety hazards they present:

- Electrical hazards, especially primary power (primary voltage on the frame can cause serious or fatal electrical shock).
- Explosive hazards, such as a damaged CRT face or bulging capacitor
- Mechanical hazards, such as loose or missing hardware

The guide consists of a series of steps presented in a checklist. Begin the checks with the power off, and the power cord disconnected.

Checklist:

1. Check exterior covers for damage (loose, broken, or sharp edges).
2. Turn off the computer. Disconnect the power cord.
3. Check the power cord for:
 - a. A third-wire ground connector in good condition. Use a meter to measure third-wire ground continuity for 0.1 ohm or less between the external ground pin and frame ground.
 - b. The power cord should be the appropriate type as specified in the parts listings.
 - c. Insulation must not be frayed or worn.
4. Remove the cover.

5. Check for any obvious non-IBM alterations. Use good judgment as to the safety of any non-IBM alterations.
6. Check inside the unit for any obvious unsafe conditions, such as metal filings, contamination, water or other liquids, or signs of fire or smoke damage.
7. Check for worn, frayed, or pinched cables.
8. Check that the power-supply cover fasteners (screws or rivets) have not been removed or tampered with.

Handling electrostatic discharge-sensitive devices

Any computer part containing transistors or integrated circuits (ICs) should be considered sensitive to electrostatic discharge (ESD). ESD damage can occur when there is a difference in charge between objects. Protect against ESD damage by equalizing the charge so that the server, the part, the work mat, and the person handling the part are all at the same charge.

Notes:

1. Use product-specific ESD procedures when they exceed the requirements noted here.
2. Make sure that the ESD-protective devices you use have been certified (ISO 9000) as fully effective.

When handling ESD-sensitive parts:

- Keep the parts in protective packages until they are inserted into the product.
- Avoid contact with other people.
- Wear a grounded wrist strap against your skin to eliminate static on your body.
- Prevent the part from touching your clothing. Most clothing is insulative and retains a charge even when you are wearing a wrist strap.
- Use the black side of a grounded work mat to provide a static-free work surface. The mat is especially useful when handling ESD-sensitive devices.
- Select a grounding system, such as those in the following list, to provide protection that meets the specific service requirement.

Note: The use of a grounding system is desirable but not required to protect against ESD damage.

- Attach the ESD ground clip to any frame ground, ground braid, or green-wire ground.
- Use an ESD common ground or reference point when working on a double-insulated or battery-operated system. You can use coax or connector-outside shells on these systems.
- Use the round ground-prong of the ac plug on ac-operated computers.

Grounding requirements

Electrical grounding of the computer is required for operator safety and correct system function. Proper grounding of the electrical outlet can be verified by a certified electrician.

Safety notices (multilingual translations)

The caution and danger safety notices in this section are provided in the following languages:

- English
- Brazilian/Portuguese
- Chinese
- French
- German
- Italian
- Japanese
- Korean
- Spanish

Important: All caution and danger statements in this IBM documentation begin with a number. This number is used to cross reference an English caution or danger statement with translated versions of the caution or danger statement in this section.

For example, if a caution statement begins with a number 1, translations for that caution statement appear in this section under statement 1.

Be sure to read all caution and danger statements before performing any of the instructions.

Statement 1



DANGER

Electrical current from power, telephone and communication cables is hazardous.

To avoid a shock hazard:

- **Do not connect or disconnect any cables or perform installation, maintenance, or reconfiguration of this product during an electrical storm.**
- **Connect all power cords to a properly wired and grounded electrical outlet.**
- **Connect to properly wired outlets any equipment that will be attached to this product.**
- **When possible, use one hand only to connect or disconnect signal cables.**
- **Never turn on any equipment when there is evidence of fire, water, or structural damage.**
- **Disconnect the attached power cords, telecommunications systems, networks, and modems before you open the device covers, unless instructed otherwise in the installation and configuration procedures.**
- **Connect and disconnect cables as described in the following table when installing, moving, or opening covers on this product or attached devices.**

To Connect	To Disconnect
<ol style="list-style-type: none">1. Turn everything OFF.2. First, attach all cables to devices.3. Attach signal cables to connectors.4. Attach power cords to outlet.5. Turn device ON.	<ol style="list-style-type: none">1. Turn everything OFF.2. First, remove power cords from outlet.3. Remove signal cables from connectors.4. Remove all cables from devices.

Statement 2



CAUTION:

When replacing the lithium battery, use only IBM Part Number 33F8354 or an equivalent type battery recommended by the manufacturer. If your system has a module containing a lithium battery, replace it only with the same module type made by the same manufacturer. The battery contains lithium and can explode if not properly used, handled, or disposed of.

Do not:

- Throw or immerse into water
- Heat to more than 100°C (212°F)
- Repair or disassemble

Dispose of the battery as required by local ordinances or regulations.

Statement 3



CAUTION:

When laser products (such as CD-ROMs, DVD-ROM drives, fiber optic devices, or transmitters) are installed, note the following:

- Do not remove the covers. Removing the covers of the laser product could result in exposure to hazardous laser radiation. There are no serviceable parts inside the device.
- Use of controls or adjustments or performance of procedures other than those specified herein might result in hazardous radiation exposure.



DANGER

Some laser products contain an embedded Class 3A or Class 3B laser diode. Note the following:

Laser radiation when open. Do not stare into the beam, do not view directly with optical instruments, and avoid direct exposure to the beam.

Statement 4

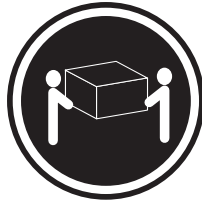

≥18 kg (39.7 lb)



≥32 kg (70.5 lb)

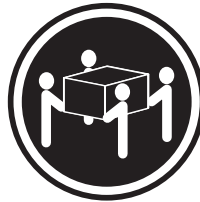

≥55 kg (121.2 lb)

CAUTION:
Use safe practices when lifting.

Statement 5



CAUTION:

The power control button on the device and the power switch on the power supply do not turn off the electrical current supplied to the device. The device also might have more than one power cord. To remove all electrical current from the device, ensure that all power cords are disconnected from the power source.

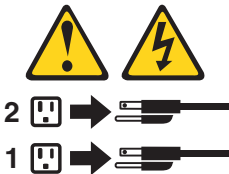

Statement 10

CAUTION:

Do not place any object weighing more than 82 kg (180 lbs.) on top of rack-mounted devices.



Importante:

Todas as instruções de cuidado e perigo da IBM documentation começam com um número. Este número é utilizado para fazer referência cruzada de uma instrução de cuidado ou perigo no idioma inglês com as versões traduzidas das instruções de cuidado ou perigo encontradas nesta seção.

Por exemplo, se uma instrução de cuidado é iniciada com o número 1, as traduções para aquela instrução de cuidado aparecem nesta seção sob a instrução 1.

Certifique-se de ler todas as instruções de cuidado e perigo antes de executar qualquer operação.

Instrução 1



PERIGO

A corrente elétrica proveniente de cabos de alimentação, de telefone e de comunicações é perigosa.

Para evitar risco de choque:

- Não conecte ou desconecte cabos e não realize instalação, manutenção ou reconfiguração deste produto durante uma tempestade com raios.
- Conecte todos os cabos de alimentação a tomadas elétricas corretamente instaladas e aterradas.
- Conecte todos os equipamentos ao qual esse produto será conectado a tomadas corretamente instaladas.
- Sempre que possível, utilize apenas uma das mãos para conectar ou desconectar cabos de sinal.
- Nunca ligue qualquer equipamento quando existir evidência de danos por fogo, água ou na estrutura.
- Desconecte cabos de alimentação, sistemas de telecomunicação, redes e modems antes de abrir as tampas dos dispositivos, a menos que especificado de maneira diferente nos procedimentos de instalação e configuração.
- Conecte e desconecte cabos conforme descrito na seguinte tabela, ao instalar ou movimentar este produto ou os dispositivos conectados, ou ao abrir suas tampas.

Para Conectar:	Para Desconectar:
<ol style="list-style-type: none">1. DESLIGUE Tudo.2. Primeiramente, conecte todos os cabos aos dispositivos.3. Conecte os cabos de sinal aos conectores.4. Conecte os cabos de alimentação às tomadas.5. LIGUE os dispositivos.	<ol style="list-style-type: none">1. DESLIGUE Tudo.2. Primeiramente, remova os cabos de alimentação das tomadas.3. Remova os cabos de sinal dos conectores.4. Remova todos os cabos dos dispositivos.

Instrução 2



CUIDADO:

Ao substituir a bateria de lítio, utilize apenas uma bateria IBM, Número de Peça 33F8354 ou uma bateria de tipo equivalente, recomendada pelo fabricante. Se o seu sistema possui um módulo com uma bateria de lítio, substitua-o apenas pelo mesmo tipo de módulo, do mesmo fabricante. A bateria contém lítio e pode explodir se não for utilizada, manuseada e descartada de maneira correta.

Não:

- Jogue ou coloque na água
- Aqueça a mais de 100°C (212°F)
- Conserte nem desmonte

Para descartar a bateria, entre em contato com a área de atendimento a clientes IBM, pelo telefone (011) 889-8986, para obter informações sobre como enviar a bateria pelo correio para a IBM.

Instrução 3



PRECAUCIÓN:

Quando produtos a laser (unidades de CD-ROM, unidades de DVD, dispositivos de fibra ótica, transmissores, etc.) estiverem instalados, observe o seguinte:

- Não remova as tampas. A remoção das tampas de um produto a laser pode resultar em exposição prejudicial à radiação de laser. Nenhuma peça localizada no interior do dispositivo pode ser consertada.
- A utilização de controles ou ajustes ou a execução de procedimentos diferentes dos especificados aqui pode resultar em exposição prejudicial à radiação.



PERIGO

Alguns produtos a laser contêm um diodo laser da Classe 3A ou Classe 3B embutido. Observe o seguinte:

Radiação de laser quando aberto. Não olhe diretamente para o raio a olho nu ou com instrumentos óticos, e evite exposição direta ao raio.

Instrução 4

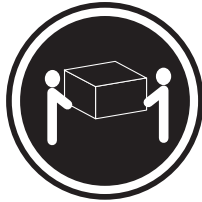

≥18 kg (39.7 lb)



≥32 kg (70.5 lb)



≥55 kg (121.2 lb)

CUIDADO:

Ao levantar a máquina, faça-o com segurança.

Instrução 5



CUIDADO:

Os botões Liga/Desliga localizados no dispositivo e na fonte de alimentação não desligam a corrente elétrica fornecida ao dispositivo. O dispositivo também pode ter mais de um cabo de alimentação. Para remover toda a corrente elétrica do dispositivo, assegure que todos os cabos de alimentação estejam desconectados da fonte de energia elétrica.



Instrução 10

CUIDADO:

Não coloque nenhum objeto com peso superior a 82 kg (180 lbs.) sobre dispositivos montados em rack.



重要:

Server Library 中的所有提醒和危险条款前都有一个数字标识。该数字是用来交叉引用一个英文的提醒和危险条款及本部分中的与之对应的已翻译成其它文字的提醒和危险条款。

例如, 如果一个提醒条款前的数字为 1, 则本部分中相应的译文也带有标号 1。

在执行任何指示的操作之前, 请确保您已经阅读了全部提醒和危险条款。

声明 1



危险

电源、电话和通信电缆中带有危险电流。
为避免电击:
雷电期间不要拆接电缆或安装、维修及重新配置本产品。
将所有电源线连接至正确布线并已安全接地的电源插座上。
将与本产品连接的所有设备连接至正确布线的插座上。
尽量只使用单手拆接信号电缆。
有水、火及结构损坏迹象时, 请勿打开任何设备。
除非在安装配置过程中有明确指示, 否则, 打开设备机盖前应先断开与电源线、远程通信系统、网络和调制解调器的所有连接。
安装、移动或打开本产品及其附带设备的机盖时, 应按下表所述连接和断开电缆。

连接时:	断开连接时:
1. 关闭所有设备。	1. 关闭所有设备。
2. 首先将所有电缆连接至设备。	2. 首先从插座中拔出电源线。
3. 将信号电缆连接至接口。	3. 从接口上拔下信号电缆。
4. 将电源线连接至插座。	

声明 2



警告:

更换锂电池时，只能使用 IBM 产品号 33F8354 或者是厂商推荐的等同类型的电池。

如果系统模块中含有锂电池，则只能使用同一厂商制造的同一类型的模块进行更换。电池中含有锂，如果使用、拿放或处理不当，可能会发生爆炸。

请勿对电池进行下列操作：
扔入或浸入水电
加热超过 100 (212 F)
进行修理或分解
请按本地法规要求处理电池。

声明 3



警告:

安装激光产品（如 CD-ROM、DVD 驱动器、光纤设备或送话器）时，应注意以下事项：

不要拆除外盖。拆除激光产品的外盖可能会导致激光辐射的危险，本设备中没有用户可维修的部件。

非此处指定的其它控制、调整或与性能有关的操作都有可能导致激光辐射的危险。



危险

某些激光产品中包含内嵌的 3A 级或 3B 级激光二极管。请注意以下事项。

打开时会产生激光辐射。不要直视光束，不要使用光学仪器直接观看光束，避免直接暴露于光束之下。

声明 4



≥18 kg (37 磅)



≥32 kg (70.5 磅)



≥55 kg (121.2 磅)

警告：
抬起时请采用安全操作方法。

声明 5



警告：

使用设备上的电源控制按钮和电源上的开关都不能断开本设备上的电流。
另外，本设备可能带有多条电源线。如要断开设备上的所有电流，请确
保所有电源线均已与电源断开连接。



声明 6



警告：

如果在电源线连接设备的一端安装了固定松紧夹，则必须将电源线的另一端连接至
使用方便的电源。

声明 7



警告:

如果设备带有外门，则在移动或抬起设备前应将其拆除或固定以避免造成人员伤害。外门支撑不了设备的重量。

声明 8



警告:

不要拆除电源外盖或贴有下列标签的任何部件。



贴有此标签的组件内部存在高电压、高电流的危险。这些组件中没有用户可维修的部件。如果怀疑其中的部件存在问题，应与服务技术人员联系。

声明 9



警告:

为避免人员伤害，拆除设备上的风扇前应拨下热插拔风扇电缆。

声明 10



警告:

机柜安装的设备上面不能放置重于 82kg (180 磅) 的物品。



> 82 kg (180 磅)

重要資訊：

Server Library 中所有「注意」及「危險」的聲明均以數字開始。此一數字是用來作為交互參考之用，英文「注意」或「危險」聲明可在本節中找到相同內容的「注意」或「危險」聲明的譯文。

例如，有一「危險」聲明以數字 1 開始，則該「危險」聲明的譯文將出現在本節的「聲明」1 中。

執行任何指示之前，請詳讀所有「注意」及「危險」的聲明。

聲明 1



危險

電源、電話及通信電纜上所產生的電流均有危險性。

欲避免電擊危險：

- 在雷雨期間，請勿連接或切斷本產品上的任何電纜線，或安裝、維修及重新架構本產品。
- 請將電源線接至接線及接地正確的電源插座。
- 請將本產品隨附的設備連接至接線正確的插座。
- 儘可能使用單手來連接或切斷信號電纜線。
- 當設備有火燒或泡水的痕跡，或有結構性損害時，請勿開啓該設備的電源。
- 在安裝及架構之時，若非非常熟悉，在開啓裝置蓋子之前，請切斷電源線、電信系統、網路及數據機。
- 在安裝、移動本產品或附加裝置，或開啓其蓋子時，請依照下表中「連接」及「切斷」電纜線的步驟執行。

連接：

1. 關閉所有開關。
2. 先將所有電纜線接上裝置。
3. 將信號電纜接上接頭。
4. 再將電源線接上電源插座。
5. 開啓裝置的電源。

切斷：

1. 關閉所有開關。
2. 先自電源插座拔掉電源線。
3. 拔掉接頭上的所有信號電纜。
4. 再拔掉裝置上的所有電纜線。

聲明 2



注意：

更換鋰電池時，只可使用 IBM 零件編號 33F8354 的電池，或製造商建議之相當類型的電池。若系統中具有包含鋰電池的模組，在更換此模組時，請使用相同廠商製造的相同模組類型。如未正確使用、處理或丟棄含有鋰的電池時，可能會引發爆炸。

請勿將電池：

- 丟入或浸入水中
- 加熱超過 100 °C (212 °F)
- 修理或拆開

請遵照當地法令規章處理廢棄電池。

聲明 3



注意：

安裝雷射產品 (如 CD-ROM、DVD 光碟機、光纖裝置或發射器) 時，請注意下列事項：

- 請勿移開蓋子。移開雷射產品的蓋子，您可能會暴露於危險的雷射輻射之下。裝置中沒有需要維修的組件。
- 不依此處所指示的控制、調整或處理步驟，您可能會暴露於危險的輻射之下。



危險

有些雷射產品含有內嵌式 Class 3A 或 Class 3B 雷射二極體。請注意下列事項：

開啓時會產生雷射輻射。請勿凝視光束，不要使用光學儀器直接觀察，且應避免直接暴露在光束下。

聲明 4



≥ 18 公斤 (37 磅) ≥ 32 公斤 (70.5 磅) ≥ 55 公斤 (121.2 磅)

注意：

抬起裝置時，請注意安全措施。

聲明 5



注意：

裝置上的電源控制按鈕及電源供應器上的電源開關均無法關閉裝置上的電流。

本裝置可能有一條以上的電源線。如要移除裝置上的所有電流，請確認所有電源線已與電源分離。



聲明 10



注意：

請勿將任何重量超過 82 公斤 (180 磅) 的物品置於已安裝機架的裝置上方。



>82 公斤 (180 磅)

Important:

Toutes les consignes Attention et Danger indiquées dans la bibliothèque IBM documentation sont précédées d'un numéro. Ce dernier permet de mettre en correspondance la consigne en anglais avec ses versions traduites dans la présente section.

Par exemple, si une consigne de type Attention est précédée du chiffre 1, ses traductions sont également précédées du chiffre 1 dans la présente section.

Prenez connaissance de toutes les consignes de type Attention et Danger avant de procéder aux opérations décrites par les instructions.

Notice n° 1



DANGER

Le courant électrique passant dans les câbles de communication, ou les cordons téléphoniques et d'alimentation peut être dangereux.

Pour éviter tout risque de choc électrique:

- Ne manipulez aucun câble et n'effectuez aucune opération d'installation, d'entretien ou de reconfiguration de ce produit au cours d'un orage.
- Branchez tous les cordons d'alimentation sur un socle de prise de courant correctement câblé et mis à la terre.
- Branchez sur des socles de prise de courant correctement câblés tout équipement connecté à ce produit.
- Lorsque cela est possible, n'utilisez qu'une seule main pour connecter ou déconnecter les câbles d'interface.
- Ne mettez jamais un équipement sous tension en cas d'incendie ou d'inondation, ou en présence de dommages matériels.
- Avant de retirer les carters de l'unité, mettez celle-ci hors tension et déconnectez ses cordons d'alimentation, ainsi que les câbles qui la relient aux réseaux, aux systèmes de télécommunication et aux modems (sauf instruction contraire mentionnée dans les procédures d'installation et de configuration).
- Lorsque vous installez ou que vous déplacez le présent produit ou des périphériques qui lui sont raccordés, reportez-vous aux instructions ci-dessous pour connecter et déconnecter les différents cordons.

Connexion	Déconnexion
<ol style="list-style-type: none">1. Mettez les unités hors tension.2. Commencez par brancher tous les cordons sur les unités.3. Branchez les câbles d'interface sur des connecteurs.4. Branchez les cordons d'alimentation sur des prises.5. Mettez les unités sous tension.	<ol style="list-style-type: none">1. Mettez les unités hors tension.2. Débranchez les cordons d'alimentation des prises.3. Débranchez les câbles d'interface des connecteurs.4. Débranchez tous les câbles des unités.

Notice n° 2



ATTENTION:

Remplacez la pile au lithium usagée par une pile de référence identique exclusivement - voir la référence IBM - ou par une pile équivalente recommandée par le fabricant. Si votre système est doté d'un module contenant une pile au lithium, vous devez le remplacer uniquement par un module identique, produit par le même fabricant. La pile contient du lithium et présente donc un risque d'explosion en cas de mauvaise manipulation ou utilisation.

- Ne la jetez pas à l'eau.
- Ne l'exposez pas à une température supérieure à 100 °C.
- Ne cherchez pas à la réparer ou à la démonter.

Pour la mise au rebut, reportez-vous à la réglementation en vigueur.

Notice n° 3



ATTENTION:

Si des produits laser sont installés (tels que des unités de CD-ROM ou de DVD, des périphériques contenant des fibres optiques ou des émetteurs-récepteurs), prenez connaissance des informations suivantes:

- N'ouvrez pas ces produits pour éviter une exposition directe au rayon laser. Vous ne pouvez effectuer aucune opération de maintenance à l'intérieur.
- Pour éviter tout risque d'exposition au rayon laser, respectez les consignes de réglage et d'utilisation des commandes, ainsi que les procédures décrites dans le présent document.



DANGER

Certains produits laser contiennent une diode laser de classe 3A ou 3B. Prenez connaissance des informations suivantes:

Rayonnement laser lorsque le carter est ouvert. évitez de regarder fixement le faisceau ou de l'observer à l'aide d'instruments optiques. évitez une exposition directe au rayon.

Notice n° 4

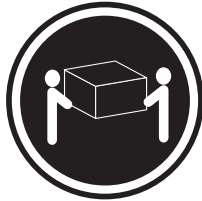

≥18 kg (39.7 lb)



≥32 kg (70.5 lb)



≥55 kg (121.2 lb)

ATTENTION:

Faites-vous aider pour soulever ce produit.

Notice n° 5



ATTENTION:

Le bouton de mise sous tension/hors tension de l'unité et l'interrupteur d'alimentation du bloc d'alimentation ne coupent pas l'arrivée de courant électrique à l'intérieur de la machine. Il se peut que votre unité dispose de plusieurs cordons d'alimentation. Pour isoler totalement l'unité du réseau électrique, débranchez tous les cordons d'alimentation des socles de prise de courant.



Notice n° 10

ATTENTION:

Ne posez pas d'objet dont le poids dépasse 82 kg sur les unités montées en armoire.



Wichtig:

Alle Sicherheitshinweise in dieser IBM documentation beginnen mit einer Nummer. Diese Nummer verweist auf einen englischen Sicherheitshinweis mit den übersetzten Versionen dieses Hinweises in diesem Abschnitt.

Wenn z. B. ein Sicherheitshinweis mit der Nummer 1 beginnt, so erscheint die Übersetzung für diesen Sicherheitshinweis in diesem Abschnitt unter dem Hinweis 1.

Lesen Sie alle Sicherheitshinweise, bevor Sie eine Anweisung ausführen.

Hinweis 1



VORSICHT

Elektrische Spannungen von Netz-, Telefon- und Datenübertragungsleitungen sind gefährlich.

Aus Sicherheitsgründen:

- Bei Gewitter an diesem Gerät keine Kabel anschließen oder lösen. Ferner keine Installations-, Wartungs- oder Rekonfigurationsarbeiten durchführen.
- Gerät nur an eine Schutzkontaktsteckdose mit ordnungsgemäß geerdetem Schutzkontakt anschließen.
- Alle angeschlossenen Geräte ebenfalls an Schutzkontaktsteckdosen mit ordnungsgemäß geerdetem Schutzkontakt anschließen.
- Signalkabel möglichst einhändig anschließen oder lösen.
- Keine Geräte einschalten, wenn die Gefahr einer Beschädigung durch Feuer, Wasser oder andere Einflüsse besteht.
- Die Verbindung zu den angeschlossenen Netzkabeln, Telekommunikationssystemen, Netzwerken und Modems ist vor dem Öffnen des Gehäuses zu unterbrechen. Es sei denn, dies ist in den zugehörigen Installations- und Konfigurationsprozeduren anders angegeben.
- Nur nach den nachfolgend aufgeführten Anweisungen arbeiten, die für Installation, Transport oder Öffnen von Gehäusen von Personal Computern oder angeschlossenen Einheiten gelten.

Kabel anschließen:	Kabel lösen:
<ol style="list-style-type: none">1. Alle Geräte ausschalten und Netzstecker ziehen.2. Zuerst alle Kabel an Einheiten anschließen.3. Signalkabel an Anschlußbuchsen anschließen.4. Netzstecker an Steckdose anschließen.5. Gerät einschalten.	<ol style="list-style-type: none">1. Alle Geräte ausschalten.2. Zuerst Netzstecker von Steckdose lösen.3. Signalkabel von Anschlußbuchsen lösen.4. Alle Kabel von Einheiten lösen.

Hinweis 2



ACHTUNG:

Eine verbrauchte Batterie nur durch eine Batterie mit der IBM Teilenummer 33F8354 oder durch eine vom Hersteller empfohlene Batterie ersetzen. Wenn Ihr System ein Modul mit einer Lithium-Batterie enthält, ersetzen Sie es immer mit dem selben Modultyp vom selben Hersteller. Die Batterie enthält Lithium und kann bei unsachgemäßer Verwendung, Handhabung oder Entsorgung explodieren.

Die Batterie nicht:

- mit Wasser in Berührung bringen.
- über 100 C erhitzen.
- reparieren oder zerlegen.

Die örtlichen Bestimmungen für die Entsorgung von Sondermüll beachten.

Hinweis 3



ACHTUNG:

Wenn ein Laserprodukt (z. B. CD-ROM-Laufwerke, DVD-Laufwerke, Einheiten mit Glasfaserkabeln oder Transmitter) installiert ist, beachten Sie folgendes.

- Das Entfernen der Abdeckungen des CD-ROM-Laufwerks kann zu gefährlicher Laserstrahlung führen. Es befinden sich keine Teile innerhalb des CD-ROM-Laufwerks, die vom Benutzer gewartet werden müssen. Die Verkleidung des CD-ROM-Laufwerks nicht öffnen.
- Steuer- und Einstellelemente sowie Verfahren nur entsprechend den Anweisungen im vorliegenden Handbuch einsetzen. Andernfalls kann gefährliche Laserstrahlung auftreten.



VORSICHT

Manche CD-ROM-Laufwerke enthalten eine eingebaute Laserdiode der Klasse 3A oder 3B. Die nachfolgend aufgeführten Punkte beachten.

Laserstrahlung bei geöffneter Tür. Niemals direkt in den Laserstrahl sehen, nicht direkt mit optischen Instrumenten betrachten und den Strahlungsbereich meiden.

Hinweis 4

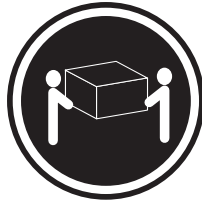

≥18 kg



≥32 kg

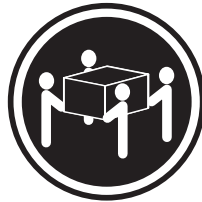

≥55 kg

ACHTUNG:

Beim Anheben der Maschine die vorgeschriebenen Sicherheitsbestimmungen beachten.

Hinweis 5



ACHTUNG:

Mit dem Betriebsspannungsschalter an der Vorderseite des Servers und dem Betriebsspannungsschalter am Netzteil wird die Stromversorgung für den Server nicht unterbrochen. Der Server könnte auch mehr als ein Netzkabel aufweisen. Um die gesamte Stromversorgung des Servers auszuschalten, muß sichergestellt werden, daß alle Netzkabel aus den Netzsteckdosen herausgezogen wurden.



Hinweis 10

ACHTUNG:

Keine Gegenstände, die mehr als 82 kg wiegen, auf Rack-Einheiten ablegen.



Importante:

Tutti gli avvisi di attenzione e di pericolo riportati nella pubblicazione IBM documentation iniziano con un numero. Questo numero viene utilizzato per confrontare avvisi di attenzione o di pericolo in inglese con le versioni tradotte riportate in questa sezione.

Ad esempio, se un avviso di attenzione inizia con il numero 1, la relativa versione tradotta è presente in questa sezione con la stessa numerazione.

Prima di eseguire una qualsiasi istruzione, accertarsi di leggere tutti gli avvisi di attenzione e di pericolo.

Avviso 1



PERICOLO

La corrente elettrica circolante nei cavi di alimentazione, del telefono e di segnale è pericolosa.

Per evitare il pericolo di scosse elettriche:

- Non collegare o scollegare i cavi, non effettuare l'installazione, la manutenzione o la riconfigurazione di questo prodotto durante i temporali.
- Collegare tutti i cavi di alimentazione ad una presa elettrica correttamente cablata e munita di terra di sicurezza.
- Collegare qualsiasi apparecchiatura collegata a questo prodotto ad una presa elettrica correttamente cablata e munita di terra di sicurezza.
- Quando possibile, collegare o scollegare i cavi di segnale con una sola mano.
- Non accendere qualsiasi apparecchiatura in presenza di fuoco, acqua o se sono presenti danni all'apparecchiatura stessa.
- Scollegare i cavi di alimentazione, i sistemi di telecomunicazioni, le reti e i modem prima di aprire i coperchi delle unità, se non diversamente indicato nelle procedure di installazione e configurazione.
- Collegare e scollegare i cavi come descritto nella seguente tabella quando si effettuano l'installazione, la rimozione o l'apertura dei coperchi di questo prodotto o delle unità collegate.

Per collegare:	Per scollegare:
<ol style="list-style-type: none">1. SPEGNERE tutti i dispositivi.2. Collegare prima tutti i cavi alle unità.3. Collegare i cavi di segnale ai connettori.4. Collegare i cavi di alimentazione alle prese elettriche.5. ACCENDERE le unità.	<ol style="list-style-type: none">1. SPEGNERE tutti i dispositivi.2. Rimuovere prima i cavi di alimentazione dalle prese elettriche.3. Rimuovere i cavi di segnale dai connettori.4. Rimuovere tutti i cavi dalle unità.

Avviso 2



ATTENZIONE:

Quando si sostituisce la batteria al litio, utilizzare solo una batteria IBM con numero parte 33F8354 o batterie dello stesso tipo o di tipo equivalente consigliate dal produttore. Se il sistema di cui si dispone è provvisto di un modulo contenente una batteria al litio, sostituire tale batteria solo con un tipo di modulo uguale a quello fornito dal produttore. La batteria contiene litio e può esplodere se utilizzata, maneggiata o smaltita impropriamente.

Evitare di:

- Gettarla o immergerla in acqua
- Riscaldarla ad una temperatura superiore ai 100°C
- Cercare di ripararla o smontarla

Smaltire secondo la normativa in vigore (D.Lgs 22 del 5/2/9) e successive disposizioni nazionali e locali.

Avviso 3



ATTENZIONE:

Quando si installano prodotti laser come, ad esempio, le unità DVD, CD-ROM, a fibre ottiche o trasmettitori, prestare attenzione a quanto segue:

- Non rimuovere i coperchi. L'apertura dei coperchi di prodotti laser può determinare l'esposizione a radiazioni laser pericolose. All'interno delle unità non vi sono parti su cui effettuare l'assistenza tecnica.
- L'utilizzo di controlli, regolazioni o l'esecuzione di procedure non descritti nel presente manuale possono provocare l'esposizione a radiazioni pericolose.



PERICOLO

Alcuni prodotti laser contengono all'interno un diodo laser di Classe 3A o Classe 3B. Prestare attenzione a quanto segue:

Aperto l'unità vengono emesse radiazioni laser. Non fissare il fascio, non guardarlo direttamente con strumenti ottici ed evitare l'esposizione diretta al fascio.

Avviso 4

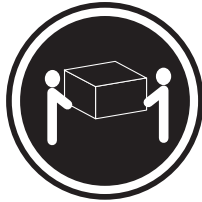

≥18 kg



≥32 kg



≥55 kg

ATTENZIONE:

Durante il sollevamento della macchina seguire delle norme di sicurezza.

Avviso 5



ATTENZIONE:

Il pulsante del controllo dell'alimentazione situato sull'unità e l'interruttore di alimentazione posto sull'alimentatore non disattiva la corrente elettrica fornita all'unità. L'unità potrebbe disporre di più di un cavo di alimentazione. Per disattivare la corrente elettrica dall'unità, accertarsi che tutti i cavi di alimentazione siano scollegati dalla sorgente di alimentazione.



Avviso 10

ATTENZIONE:

Non poggiare oggetti che pesano più di 82 kg sulla parte superiore delle unità montate in rack.



重要:

Netfinity Server ライブラリーにあるすべての注意および危険の記述は数字で始まります。この数字は、英語版の注意および危険の記述と翻訳された注意および危険の記述を相互参照するために使用します。

例えば、もし注意の記述が数字の1で始まっている場合は、その注意の翻訳は、記述1の下にあります。

手順を実施する前に、すべての注意:

・記述 1

⚠ 危険

感電を防止するため、雷の発生時には、いかなるケーブルの取り付けまたは取り外しも行わないでください。また導入、保守、再構成などの作業も行わないでください。

感電を防止するため:

- 電源コードは正しく接地および配線が行われている電源に接続してください。
- 本製品が接続されるすべての装置もまた正しく配線された電源に接続されている必要があります。

できれば、信号ケーブルに取り付けまたは取り外しのときは片方の手のみで行うようにしてください。これにより、電位差がある二つの表面に触ることによる感電を防ぐことができます。

電源コード、電話ケーブル、通信ケーブルからの電流は身体に危険を及ぼします。設置、移動、または製品のカバーを開けたり装置を接続したりするときには、以下のようにケーブルの接続、取り外しを行ってください。

接続するには	取り外すには
1. すべての電源を切る	1. すべての電源を切る
2. まず、装置にすべてのケーブルを接続する。	2. まず、電源コンセントから電源コードを取り外す
3. 次に、通信ケーブルをコネクタに接続する	3. 次に、通信ケーブルをコネクタから取り外す。
4. その後、電源コンセントに電源コードを接続する	4. その後、装置からすべてのケーブルを取り外す
5. 装置の電源を入れる。	

・記述 2

⚠ 注意

本製品には、システム・ボード上にリチウム電池が使用されています。電池の交換方法や取り扱いを誤ると、発熱、発火、破裂のおそれがあります。

電池の交換には、IBM部品番号33F8354の電池またはメーカー推奨の同等の電池を使用してください。

交換用電池の購入については、お買い求めの販売店または弊社の営業担当までお問い合わせください。

電池は幼児の手の届かない所に置いてください。

万一、幼児が電池を飲み込んだときは、直ちに医師に相談してください。

以下の行為は絶対にしないでください。

- 水にぬらすこと
- 100度C以上の過熱や焼却
- 分解や充電
- ショート

電池を廃棄する場合、および保存する場合にはテープなどで絶縁してください。他の金属や電池と混ざると発火、破裂の原因となります。電池は地方自治体の条例、または規則に従って廃棄してください。ごみ廃棄場で処分されるごみの中に捨てないでください。

・記述 3

⚠ 注意

レーザー製品 (CD-ROM、DVD、または光ファイバー装置または送信器など) が組み込まれている場合は、下記に御注意ください。

- ここに記載されている制御方法、調整方法、または性能を超えて使用すると、危険な放射線を浴びる可能性があります。
- ドライブのカバーを開けると、危険な放射線を浴びる可能性があります。ドライブの内部に修理のために交換可能な部品はありません。カバーを開けないでください。

⚠ 危険

一部 CD-ROM ドライブは、Class 3A または Class 3B レーザーダイオードを使用しています。次の点に注意してください。

CD-ROMドライブのカバーを開けるとレーザーが放射されます。光線を見つめたり、光学器械を使って直接見たりしないでください。また直接光線を浴びないようにしてください。

・記述 4

⚠ 注意



18kg 以上



32kg 以上



55kg 以上

装置を持ち上げる場合は、安全に持ち上げる方法に従ってください。

・記述 5

⚠ 注意 ⚡

サーバーの前面にある電源制御ボタンは、サーバーに供給された電流を遮断しません。サーバーには、複数の電源コードが接続されているかもしれません。サーバーから電流を完全に遮断するために、すべての電源コードが電源から取り外されていることを確認してください。

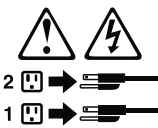

・記述 10

⚠ 注意

ラック・モデルのサーバーの上に 82 kg 以上の物を置かないでください。



중요:

본 *Server Library*에 있는 모든 주의 및 위험 경고문은 번호로 시작합니다. 이 번호는 영문 주의 혹은 위험 경고문과 이 절에 나오는 번역된 버전의 주의 혹은 위험 경고문을 상호 참조하는 데 사용됩니다.

예를 들어, 주의 경고문이 번호 1로 시작하면, 번역된 해당 주의 경고문을 본 절의 경고문 1에서 찾아볼 수 있습니다.

모든 지시사항을 수행하기 전에 반드시 모든 주의 및 위험 경고문을 읽으십시오.

경고문 1

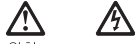

위험

전원, 전황 및 통신 케이블로부터 흘러 나오는 전류는 위험합니다.

전기 충격을 피하려면:

- 뇌우를 동반할 때는 케이블의 연결이나 철수, 이 제품의 설치, 유지보수 또는 재구성을 하지 마십시오.
- 모든 전원 코드를 적절히 배선 및 접지해야 합니다.
- 이 제품에 연결될 모든 장비를 적절하게 배선된 콘센트에 연결하십시오.
- 가능한 신호 케이블을 한 손으로 연결하거나 끊으십시오.
- 화재, 수해 또는 구조상의 손상이 있을 경우 장비를 꺼지 마십시오.
- 설치 및 구성 프로시저에 다른 설명이 없는 한, 장치 덮개를 열기 전에 연결된 전원 코드, 원거리 통신 시스템, 네트워크 및 모뎀을 끊어 주십시오.
- 제품 또는 접속된 장치를 설치, 이동 및 덮개를 열 때 다음 설명에 따라 케이블을 연결하거나 끊도록 하십시오.

<p>연결하려면:</p> <ol style="list-style-type: none"> 1. 모든 스위치를 끕니다. 2. 먼저 모든 케이블을 장치에 연결합니다. 3. 신호 케이블을 커넥터에 연결합니다. 4. 콘센트에 전원 코드를 연결합니다. 5. 장치 스위치를 켭니다. 	<p>연결을 끊으려면:</p> <ol style="list-style-type: none"> 1. 모든 스위치를 끕니다. 2. 먼저 콘센트에서 전원 코드를 뽑습니다. 3. 신호 케이블을 커넥터에서 제거합니다. 4. 장치에서 모든 케이블을 제거합니다.
---	---

경고문 2



주의:

리튬 배터리를 교체할 때는 IBM 부품 번호 33F8354 또는 제조업체에서 권장하는 동등한 유형의 배터리를 사용하십시오. 시스템에 리튬 배터리를 갖고 있는 모듈이 있으면 동일한 제조업체에서 생산된 동일한 모듈 유형으로 교체하십시오. 배터리에 리튬이 있을 경우 제대로 사용, 처리 또는 처분하지 않으면 폭발할 수 있습니다.

다음은 주의하십시오.

- 던지거나 물에 담그지 않도록 하십시오.
- 100°C(212°F) 이상으로 가열하지 마십시오.
- 수리하거나 분해하지 마십시오.

지역 법령이나 규정의 요구에 따라 배터리를 처분하십시오.

경고문 3



주의:

레이저 제품(CD-ROMs, DVD 드라이브, 광 장치 또는 트랜스미터 등과 같은)이 설치되어 있을 경우 다음을 유의하십시오.

- 덮개를 제거하지 마십시오. 레이저 제품의 덮개를 제거했을 경우 위험한 레이저 광선에 노출될 수 있습니다. 이 장치 안에는 서비스를 받을 수 있는 부품이 없습니다.

- 여기에서 지정하지 않은 방식의 제어, 조절 또는 실행으로 인해 위험한 레이저 광선에 노출될 수 있습니다.



위험

일부 레이저 제품에는 클래스 3A 또는 클래스 3B 레이저 다이오드가 들어 있습니다. 다음을 주의하십시오.

열면 레이저 광선에 노출됩니다. 광선을 주시하거나 광학 기계를 직접 쳐다보지 않도록 하고 광선에 노출되지 않도록 하십시오.

경고문 4



≥18 kg (37 lbs)



≥ 32 kg (70.5 lbs)



≥ 55 kg (121.2 lbs)

주의:

기계를 들 때는 안전하게 들어 올리십시오.

경고문 5



주의:

장치의 전원 제어 버튼 및 전원 공급기의 전원 스위치는 장치에 공급되는 전류를 차단하지 않습니다. 장치에 둘 이상의 전원 코드가 연결되어 있을 수도 있습니다. 장치에서 모든 전류를 차단하려면 모든 전원 코드가 전원으로부터 차단되어 있는지 확인하십시오.



경고문 10



주의:

서랍형 모델의 장치 상단에 82 kg(180 lbs.)이 넘는 물체를 올려 놓지 마십시오.



>82 kg (180 lbs)

Importante:

Todas las declaraciones de precaución de esta IBM documentation empiezan con un número. Dicho número se emplea para establecer una referencia cruzada de una declaración de precaución o peligro en inglés con las versiones traducidas que de dichas declaraciones pueden encontrarse en esta sección.

Por ejemplo, si una declaración de peligro empieza con el número 1, las traducciones de esta declaración de precaución aparecen en esta sección bajo Declaración 1.

Lea atentamente todas las declaraciones de precaución y peligro antes de llevar a cabo cualquier operación.

Declaración 1



PELIGRO

La corriente eléctrica de los cables telefónicos, de alimentación y de comunicaciones es perjudicial.

Para evitar una descarga eléctrica:

- No conecte ni desconecte ningún cable ni realice las operaciones de instalación, mantenimiento o reconfiguración de este producto durante una tormenta.
- Conecte cada cable de alimentación a una toma de alimentación eléctrica con conexión a tierra y cableado correctos.
- Conecte a tomas de alimentación con un cableado correcto cualquier equipo que vaya a estar conectado a este producto.
- Si es posible, utilice una sola mano cuando conecte o desconecte los cables de sent.al.
- No encienda nunca un equipo cuando haya riesgos de incendio, de inundación o de daños estructurales.
- Desconecte los cables de alimentación, sistemas de telecomunicaciones, redes y módems conectados antes de abrir las cubiertas del dispositivo a menos que se indique lo contrario en los procedimientos de instalación y configuración.
- Conecte y desconecte los cables tal como se describe en la tabla siguiente cuando desee realizar una operación de instalación, de traslado o de apertura de las cubiertas para este producto o para los dispositivos conectados.

Para la conexión	Para la desconexión
<ol style="list-style-type: none">1. APÁGUELO todo.2. En primer lugar, conecte los cables a los dispositivos.3. Conecte los cables de señal a los conectores.4. Conecte cada cable de alimentación a la toma de alimentación.5. ENCIENDA el dispositivo.	<ol style="list-style-type: none">1. APÁGUELO todo.2. En primer lugar, retire cada cable de alimentación de la toma de alimentación.3. Retire los cables de señal de los conectores.4. Retire los cables de los dispositivos.

Declaración 2



PRECAUCIÓN:

Cuando desee sustituir la batería de litio, utilice únicamente el número de pieza 33F8354 de IBM o cualquier tipo de batería equivalente que recomiende el fabricante. Si el sistema tiene un módulo que contiene una batería de litio, sustitúyalo únicamente por el mismo tipo de módulo, que ha de estar creado por el mismo fabricante. La batería contiene litio y puede explotar si el usuario no la utiliza ni la maneja de forma adecuada o si no se desprende de la misma como corresponde.

No realice las acciones siguientes:

- Arrojarla al agua o sumergirla
- Calentarla a una temperatura que supere los 100°C (212°F)
- Repararla o desmontarla

Despréndase de la batería siguiendo los requisitos que exija el reglamento o la legislación local.

Declaración 3



PRECAUCIÓN:

Cuando instale productos láser (como, por ejemplo, CD-ROM, unidades DVD, dispositivos de fibra óptica o transmisores), tenga en cuenta las advertencias siguientes:

- No retire las cubiertas. Si retira las cubiertas del producto láser, puede quedar expuesto a radiación láser perjudicial. Dentro del dispositivo no existe ninguna pieza que requiera mantenimiento.
- El uso de controles o ajustes o la realización de procedimientos que no sean los que se han especificado aquí pueden dar como resultado una exposición perjudicial a las radiaciones.



PELIGRO

Algunos productos láser contienen un diodo de láser incorporado de Clase 3A o de Clase 3B. Tenga en cuenta la advertencia siguiente.

Cuando se abre, hay radiación láser. No mire fijamente el rayo ni lleve a cabo ningún examen directamente con instrumentos ópticos; evite la exposición directa al rayo.

Declaración 4

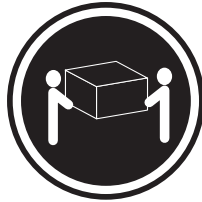

≥18 kg



≥32 kg

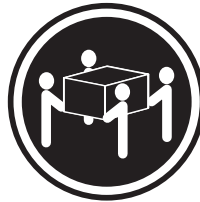

≥55 kg

PRECAUCIÓN:

Tome medidas de seguridad al levantar el producto.

Declaración 5



PRECAUCIÓN:

El botón de control de alimentación del dispositivo y el interruptor de alimentación de la fuente de alimentación no apagan la corriente eléctrica suministrada al dispositivo. Es posible también que el dispositivo tenga más de un cable de alimentación. Para eliminar la corriente eléctrica del dispositivo, asegúrese de desconectar todos los cables de alimentación de la fuente de alimentación.



Declaración 10

PRECAUCIÓN:

No coloque ningún objeto que pese más de 82 kg (180 libras) encima de los dispositivos montados en bastidor.



Appendix C. Notices

This publication was developed for products and services offered in the U.S.A.

IBM may not offer the products, services, or features discussed in this document in other countries. Consult your local IBM representative for information on the products and services currently available in your area. Any reference to an IBM product, program, or service is not intended to state or imply that only that IBM product, program, or service may be used. Any functionally equivalent product, program, or service that does not infringe any IBM intellectual property right may be used instead. However, it is the user's responsibility to evaluate and verify the operation of any non-IBM product, program, or service.

IBM may have patents or pending patent applications covering subject matter described in this document. The furnishing of this document does not give you any license to these patents. You can send license inquiries, in writing, to:

*IBM Director of Licensing
IBM Corporation
North Castle Drive
Armonk, NY 10504-1785
U.S.A.*

INTERNATIONAL BUSINESS MACHINES CORPORATION PROVIDES THIS PUBLICATION "AS IS" WITHOUT WARRANTY OF ANY KIND, EITHER EXPRESS OR IMPLIED, INCLUDING, BUT NOT LIMITED TO, THE IMPLIED WARRANTIES OF NON-INFRINGEMENT, MERCHANTABILITY OR FITNESS FOR A PARTICULAR PURPOSE. Some jurisdictions do not allow disclaimer of express or implied warranties in certain transactions, therefore, this statement may not apply to you.

This information could include technical inaccuracies or typographical errors. Changes are periodically made to the information herein; these changes will be incorporated in new editions of the publication. IBM may make improvements and/or changes in the product(s) and/or the program(s) described in this publication at any time without notice.

Any references in this publication to non-IBM Web sites are provided for convenience only and do not in any manner serve as an endorsement of those Web sites. The materials at those Web sites are not part of the materials for this IBM product, and use of those Web sites is at your own risk.

IBM may use or distribute any of the information you supply in any way it believes appropriate without incurring any obligation to you.

Edition notice

© Copyright International Business Machines Corporation 2004. All rights reserved.

U.S. Government Users Restricted Rights — Use, duplication, or disclosure restricted by GSA ADP Schedule Contract with IBM Corp.

Trademarks

The following terms are trademarks of International Business Machines Corporation in the United States, other countries, or both:

Active Memory	Predictive Failure Analysis
Active PCI	ServeRAID
Active PCI-X	ServerGuide
Alert on LAN	ServerProven
BladeCenter	TechConnect
C2T Interconnect	ThinkPad
Chipkill	Tivoli
EtherJet	Tivoli Enterprise
FlashCopy	Update Connector
IBM	Wake on LAN
IBM (logo)	XA-32
IntelliStation	XA-64
NetBAY	X-Architecture
Netfinity	XceL4
NetView	XpandOnDemand
OS/2 WARP	xSeries

Intel, MMX, and Pentium are trademarks of Intel Corporation in the United States, other countries, or both.

Microsoft, Windows, and Windows NT are trademarks of Microsoft Corporation in the United States, other countries, or both.

UNIX is a registered trademark of The Open Group in the United States and other countries.

Java and all Java-based trademarks and logos are trademarks or registered trademarks of Sun Microsystems, Inc. in the United States, other countries, or both.

Adaptec and HostRAID are trademarks of Adaptec, Inc., in the United States, other countries, or both.

Linux is a trademark of Linus Torvalds in the United States, other countries, or both.

Red Hat, the Red Hat "Shadow Man" logo, and all Red Hat-based trademarks and logos are trademarks or registered trademarks of Red Hat, Inc., in the United States and other countries.

Other company, product, or service names may be trademarks or service marks of others.

Important notes

Processor speeds indicate the internal clock speed of the microprocessor; other factors also affect application performance.

CD-ROM drive speeds list the variable read rate. Actual speeds vary and are often less than the maximum possible.

When referring to processor storage, real and virtual storage, or channel volume, KB stands for approximately 1000 bytes, MB stands for approximately 1 000 000 bytes, and GB stands for approximately 1 000 000 000 bytes.

When referring to hard disk drive capacity or communications volume, MB stands for 1 000 000 bytes, and GB stands for 1 000 000 000 bytes. Total user-accessible capacity may vary depending on operating environments.

Maximum internal hard disk drive capacities assume the replacement of any standard hard disk drives and population of all hard disk drive bays with the largest currently supported drives available from IBM.

Maximum memory may require replacement of the standard memory with an optional memory module.

IBM makes no representation or warranties regarding non-IBM products and services that are ServerProven[®], including but not limited to the implied warranties of merchantability and fitness for a particular purpose. These products are offered and warranted solely by third parties.

IBM makes no representations or warranties with respect to non-IBM products. Support (if any) for the non-IBM products is provided by the third party, not IBM.

Some software may differ from its retail version (if available), and may not include user manuals or all program functionality.

Product recycling and disposal

This unit contains materials such as circuit boards, cables, electromagnetic compatibility gaskets, and connectors which may contain lead and copper/beryllium alloys that require special handling and disposal at end of life. Before this unit is disposed of, these materials must be removed and recycled or discarded according to applicable regulations. IBM offers product-return programs in several countries. Information on product recycling offerings can be found on IBM's Internet site at <http://www.ibm.com/ibm/environment/products/prp.shtml>.

Battery return program

This product may contain a sealed lead acid, nickel cadmium, nickel metal hydride, lithium, or lithium ion battery. Consult your user manual or service manual for specific battery information. The battery must be recycled or disposed of properly. Recycling facilities may not be available in your area. For information on disposal of batteries outside the United States, go to <http://www.ibm.com/ibm/environment/products/batteryrecycle.shtml> or contact your local waste disposal facility.

In the United States, IBM has established a collection process for reuse, recycling, or proper disposal of used IBM sealed lead acid, nickel cadmium, nickel metal hydride, and battery packs from IBM equipment. For information on proper disposal of these batteries, contact IBM at 1-800-426-4333. Have the IBM part number listed on the battery available prior to your call.

In the Netherlands, the following applies.



Electronic emission notices

IBM IntelliStation Z Pro Types 6223 and 6227

Federal Communications Commission (FCC) statement

Note: This equipment has been tested and found to comply with the limits for a Class B digital device, pursuant to Part 15 of the FCC Rules. These limits are designed to provide reasonable protection against harmful interference in a residential installation. This equipment generates, uses, and can radiate radio frequency energy and, if not installed and used in accordance with the instructions, may cause harmful interference to radio communications. However, there is no guarantee that interference will not occur in a particular installation. If this equipment does cause harmful interference to radio or television reception, which can be determined by turning the equipment off and on, the user is encouraged to try to correct the interference by one or more of the following measures:

- Reorient or relocate the receiving antenna.
- Increase the separation between the equipment and receiver.
- Connect the equipment into an outlet on a circuit different from that to which the receiver is connected.
- Consult an IBM authorized dealer or service representative for help.

Properly shielded and grounded cables and connectors must be used in order to meet FCC emission limits. Proper cables and connectors are available from IBM authorized dealers. IBM is not responsible for any radio or television interference caused by using other than recommended cables and connectors or by unauthorized changes or modifications to this equipment. Unauthorized changes or modifications could void the user's authority to operate the equipment.

This device complies with Part 15 of the FCC Rules. Operation is subject to the following two conditions: (1) this device may not cause harmful interference, and (2) this device must accept any interference received, including interference that may cause undesired operation.

Responsible party:

International Business Machines Corporation
New Orchard Road
Armonk, NY 10504
Telephone: 1-919-543-2193



Tested To Comply
With FCC Standards

FOR HOME OR OFFICE USE

Industry Canada Class B emission compliance statement

This Class B digital apparatus complies with Canadian ICES-003.

Avis de conformité à la réglementation d'Industrie Canada

Cet appareil numérique de la classe B est conforme à la norme NMB-003 du Canada.

European Union EMC Directive conformance statement

This product is in conformity with the protection requirements of EU Council Directive 89/336/EEC on the approximation of the laws of the Member States relating to electromagnetic compatibility. IBM cannot accept responsibility for any failure to satisfy the protection requirements resulting from a nonrecommended modification of the product, including the fitting of non-IBM option cards. This product has been tested and found to comply with the limits for Class B Information Technology Equipment according to CISPR 22/European Standard EN 55022. The limits for Class B equipment were derived for typical residential environments to provide reasonable protection against interference with licensed communication devices.

Japanese Voluntary Control Council for Interference (VCCI) statement

この装置は、情報処理装置等電波障害自主規制協議会（VCCI）の基準に基づくクラスB情報技術装置です。この装置は、家庭環境で使用することを目的としていますが、この装置がラジオやテレビジョン受信機に近接して使用されると、受信障害を引き起こすことがあります。
取扱説明書に従って正しい取り扱いをして下さい。

Index

A

- acoustical noise emissions 3
- adapter
 - considerations for 26
 - PCI bus 27
 - PCI or PCI-X 27
 - SCSI 30
- adapter-retainer, rear, removing 63, 64
- audio
 - connectors 54

B

- battery
 - connector 71
 - replacement 21
- bays, filler panel 33
- beep
 - symptoms 83
- beep codes 15
- bezel
 - removing 26
 - replacing 50
- bezel release latch, removing 79
- bi-directional parallel port configuration 56
- BIOS code, updating 18
- Boot Menu 11
- Broadcom NetXtreme Gigabit Ethernet Boot Agent
 - general 11

C

- cable connectors 72, 73
- cables
 - internal drives 40
 - power 40
 - signal 40
 - USB 57
- cabling
 - Ethernet 54
 - external SCSI connector 48
 - SCSI adapter 30
 - SCSI drives 40
 - SCSI requirements 56
 - Serial ATA drives 40
 - system-board external connectors 73
 - system-board internal connectors 72
- CD-ROM drive
 - eject button 7
 - installing 31
 - problems 95
 - removing 61
- channels, SCSI 56
- checkout
 - general 13
 - procedure 14

- components
 - location of 24
 - system 24
 - system board 71
- computer
 - configuring 11
 - controls on 6
 - indicators on 6
 - turning off 9
 - turning on 8
- configuration
 - ServeRAID programs 11
- configuration programs
 - Adaptec RAID Configuration Utility programs 11
 - Broadcom NetXtreme Gigabit Ethernet Boot Agent 11
 - Configuration/Setup Utility program 12
 - general 11
 - SCSISelect Utility program 11
 - Configuration/Setup Utility program 12
- configuring
 - the computer 11
- connecting external options 52
- connector
 - mouse 54
 - parallel port 55
 - video 57
- connectors
 - adapter 71
 - audio 54
 - battery 71
 - cable 72
 - Ethernet 54
 - external port 73
 - external SCSI 48
 - fan 72
 - front 6
 - IEEE 1394 (FireWire) 55
 - input/output 53
 - internal cable 72
 - memory 71
 - microprocessor 71
 - port 73
 - rear 53
 - serial 56
 - Serial ATA 32
 - system board 71
 - Ultra 320 SCSI 56
 - universal serial bus (USB) 57
 - VRM 71
- controller
 - Ethernet 4
 - SCSI 30
- controls and indicators 6
- cooling 3, 23
- cover
 - removing 25
 - replacing 51

CRU tier levels 117
CRUs, defined iii, 117

D

diagnostic
 CD 13
 error codes 90
 programs 17
 test log 17
 text messages 16
DIMM connector
 installing memory 42
DIMM retaining clips 42
diskette drive
 activity LED 7
 installing 31, 32
 problems 96
diskette eject button 7
display problems 98
drive
 bay filler panel 33
 installation 32, 36
drives, installing 31

E

eject button
 diskette 7
electrical input 3
Enhanced Diagnostics CD 13
environment 3
error
 LED 74
 messages, BIST 112
 messages, bus fault 112
 messages, fan 109
 messages, hard disk drive checkout 111
 messages, power 110
 messages, temperature 109
 symptoms 95
errors
 hot-swap power supply 103
 POST (ISPR) 107
 SCSI 104
 ServeRAID 105
 service processor 104
Ethernet
 cabling 54
 connector 54
 port 54
Ethernet controller 4
Ethernet controller configuration 11
external options, connecting 52

F

fan
 connectors 72
 front, removing 65
 hard drive, removing 66

features and specifications 3
filler panel 33
FRUs, defined iii, 117

G

guidelines for options installation 23

H

handle assembly, removing 81
handling static-sensitive devices 23
hard disk drive
 installing 31
hardware problems, determining 13
hardware, major components 24, 116
heat output 3
heat sink
 removing 60
HostRAID considerations 32

I

IDs, setting SCSI 56
IEEE 1394 (FireWire) connectors 55
input/output
 connectors 53
input/output connectors 53
installation sequence, memory modules 41
installing
 battery 21
 bezel 50
 drives in bays 4, 5, or 6 36
 internal drives 31
 memory modules 41
 microprocessor 44
 options 23
 SCSI cable 48
 security rope clip 49
intermittent problems 97
internal
 connectors 72
 drive bays 31
 drives, installing 31

J

jumpers and switches 75

K

keyboard problems 97

L

LEDs
 activity 6, 7
 system board 74
lever, microprocessor socket 61
local area network (LAN) 4

M

- memory
 - installing 41
 - modules 42
- memory module
 - sequence of installation 41
 - specifications 3
- memory problems 98
- messages
 - diagnostic text 16
 - small computer system interface (SCSI) 17
- microprocessor
 - heat sink 47
 - installing 44
 - problems 98
 - removing 60
 - specifications 3
- minimum operating requirements 113
- monitor problems 98
- mouse
 - connector 54
 - problems 97

N

- no-beep symptoms 85
- notes, important 163
- notices
 - book 2

O

- online
 - support iv
- operating requirements, minimum 113
- optical drive 40
- option problems 100
- options installation 23
 - guidelines 23

P

- parallel port
 - connector 55
- parts listing 115
- PC-Doctor for Windows
 - program 18
 - using 18
- PCI adapters 27
- PCI expansion slots 3
- ports
 - See connectors
- POST (ISPR) error procedures 107
- POST (power-on self-test) 15
- POST error codes 85
- POST error messages 16
- power
 - cords 122
 - problems 101

- power cords
 - disconnecting 48
- power supply
 - non-hot-swap, removing 62
- power supply specifications 3
- power-control button 6
- power-on LED 6
- power/LED switch assembly, removing 68
- problem determination tips 114
- problems
 - CD-ROM drive 95
 - diskette drive 96
 - hard disk drives 96
 - hardware, determining 13
 - intermittent 97
 - keyboard 97
 - memory 98
 - microprocessor 98
 - monitor 98
 - mouse 97
 - option 100
 - power 101
 - serial port 102
 - software 103
 - solving 13
 - undetermined 113

R

- RAS features 4
- recovering
 - POST/BIOS update failure 19
- reliability, system 23
- removable media drives, installing 31
- removing
 - bezel 26
 - cover 25
- removing/replacing
 - adapter retainer, rear 63, 64
 - bezel release latch 79
 - CD-ROM drive 61
 - fan, front 65
 - fan, hard drive 66
 - front USB connector assembly 69
 - handle assembly 81
 - microprocessor 60
 - power supply, non-hot-swap 62
 - power/LED switch assembly 68
 - system board 76
 - top/side cover 78
 - USB connector assembly 69
- replacing
 - battery 21
 - bezel 50
 - cover 51
- retaining clips, DIMM 42
- rope clip, installing for security 49

S

- safety information
 - laser 34
- SCSI
 - cabling 56
 - connector, location 72
 - external cable 48
- SCSI (Ultra320)
 - connector 56
- SCSI connector
 - description 56
 - location 48
- SCSI controller
 - cabling 30
- SCSI IDs
 - setting 56
- security
 - rope clip 49
- sequence of installation, memory modules 41
- serial
 - connectors 56
- serial port problems 102
- ServeRAID error codes 105
- ServeRAID programs 11
- ServerGuide error symptoms 102
- setting
 - SCSI IDs 56
- size 3
- small computer system interface (SCSI)
 - cabling requirements 56
 - messages 17
 - setting IDs 56
- software, problems 103
- starting
 - diagnostic programs 17
- starting the computer 8
- static-sensitive devices, handling 23
- system board
 - connectors
 - SCSI 56
 - external connectors 73
 - internal connectors 72
 - jumpers and switches 75
 - LEDs 74
 - option connectors 71
 - removing 76
 - SCSI connectors 72
- system management
 - capabilities 4
- system offerings 4
- system reliability 23
- system shutdown
 - temperature-related 111
 - voltage-related 110
- system specifications 3

T

- tape drive, installing 31

- test log
 - viewing diagnostic 17
- thermal material, heat sink 47
- tier levels, CRU 117
- top/side cover, removing 78
- trademarks 162
- turn on computer 8
- turning off the computer 9

U

- Ultra160 SCSI connector 56
- undetermined problems 113
- universal serial bus (USB)
 - cables 57
 - connectors 57
 - front connector assembly, removing 69
- USB connector assembly, removing 69

V

- video
 - connector 57
 - DVI connector 57
- video controller 3

W

- weight 3



Part Number: 49Y0147

(1P) P/N: 49Y0147



Free Manuals Download Website

<http://myh66.com>

<http://usermanuals.us>

<http://www.somanuals.com>

<http://www.4manuals.cc>

<http://www.manual-lib.com>

<http://www.404manual.com>

<http://www.luxmanual.com>

<http://aubethermostatmanual.com>

Golf course search by state

<http://golfingnear.com>

Email search by domain

<http://emailbydomain.com>

Auto manuals search

<http://auto.somanuals.com>

TV manuals search

<http://tv.somanuals.com>