

**User's Manual**

P/N 071881-001

# EasyCoder<sup>®</sup> 3400e Bar Code Label Printer

 **intermec**

A **UNOVA** Company

Intermec Technologies Corporation  
6001 36th Avenue West  
P.O. Box 4280  
Everett, WA 98203-9280

U.S. service and technical support: 1-800-755-5505  
U.S. media supplies ordering information: 1-800-227-9947

Canadian service and technical support: 1-800-668-7043  
Canadian media supplies ordering information: 1-800-268-6936

Outside U.S. and Canada: Contact your local Intermec service supplier.

The information contained herein is proprietary and is provided solely for the purpose of allowing customers to operate and/or service Intermec manufactured equipment and is not to be released, reproduced, or used for any other purpose without written permission of Intermec.

Information and specifications in this manual are subject to change without notice.

© 2001 by Intermec Technologies Corporation  
All Rights Reserved

The word Intermec, the Intermec logo, JANUS, IRL, TRAKKER, Antares, Adara, Duratherm, EZBuilder, Precision Print, PrintSet, Virtual Wedge, and CrossBar are trademarks of Intermec Technologies Corporation.

The name Centronics is wholly owned by GENICOM Corporation.

IBM is a registered trademark of International Business Machines Corporation.

Throughout this manual, trademarked names may be used. Rather than put a trademark (® or ™) symbol in every occurrence of a trademarked name, we state that we are using the names only in an editorial fashion, and to the benefit of the trademark owner, with no intention of infringement.

The software contained in the EasyCoder® 3400e Printer and the accompanying materials are copyrighted. Unauthorized copying of the software, including software that has been modified, merged, or included with other software, or the written materials is expressly forbidden without the prior written consent of Intermec. All right, title, and interest in all copies of this software are and shall at all times remain the sole and exclusive property of Intermec. Customers may be held legally responsible for any copyright infringement that is caused or encouraged by their failure to abide by these terms.

# Contents

## ***Before You Begin ix***

*Warranty Information ix*

*Safety Summary ix*

*Warnings and Cautions x*

*About This Manual xi*

## ***Other Intermec Manuals xiii***

# 1

---

## ***Getting Started***

***Getting to Know Your Printer 1-3***

***Preparing the Printer for Installation 1-5***

*Plugging In the Printer 1-5*

*Opening the Printer 1-6*

*Loading Media for Fanfold Printing 1-7*

*Printing the Hardware Configuration Test Label 1-9*

*What the Hardware Configuration Test Label Tells You 1-10*

*If a Hardware Configuration Test Label Does Not Print 1-10*

***Connecting the Printer to Your System 1-10***

*Connecting Your Printer to a PC 1-11*

*Connecting the Printer to a PC Serial Port 1-11*

*Connecting the Printer to a PC Parallel Port 1-12*

*Connecting Your Printer to a Network 1-12*

*Connecting the Printer to an AS/400 1-13*

*Connecting the Printer to a Mainframe 1-14*

*Cabling in Noisy Electrical Environments 1-14*

***Configuring the Serial Port for Communications 1-15***

***Verifying Printer Communications With Your System 1-17***

# 2

---

## ***Operating the Printer***

***Learning How to Operate the Printer 2-3***

***Understanding the Front Panel 2-3***

*Understanding the Front Panel LEDs 2-4*

*Using the Feed/Pause Button 2-5*

**Loading Media Into the Printer 2-6**

*Loading Roll Media for Straight-Through Printing 2-6*

*Loading Media for Self-Strip Printing 2-8*

**Loading Thermal Transfer Ribbon 2-10**

**Setting the Media Sensitivity Number 2-12**

*Setting the MSN for Intermec Media and Ribbon 2-13*

*Setting the MSN for Other Media and Ribbon 2-14*

**Communicating With the Printer 2-16**

*Using the PrintSet Software 2-16*

*Using Third-Party Software 2-16*

*Using Intermec Printer Language (IPL) Commands 2-16*

*Printing a Test Label 2-17*

**3**

---

**Maintaining the Printer**

*Inspecting the Printer 3-3*

*Tools for Cleaning the Printer 3-3*

**Maintenance Schedule 3-4**

*Cleaning the Printhead 3-6*

*Cleaning the Printer Covers 3-7*

*Cleaning the Drive Roller and Tear Bar 3-8*

*Cleaning the Media Guides and Media Path 3-9*

*Cleaning the Label Sensors 3-10*

**4**

---

**Troubleshooting**

*Troubleshooting Checklist 4-3*

*Printer Operation Problems 4-3*

*Print Quality Problems 4-5*

*Communication Problems and Preventing Data Loss 4-7*

**5**

---

**Optimizing Printer Performance**

*Optimizing and Maintaining Print Quality 5-3*

*Correcting Uneven Print Quality 5-3*

*Adjusting the Print Darkness 5-5*

**Adjusting the Label Mark Sensor 5-6****Using the Printer Memory Efficiently 5-8***How Is the Printer Storage Memory Used? 5-8**Making the Most of Your Memory 5-8**Increasing Throughput 5-9**What Is an Image Band? 5-9**How the Image Bands Command Works 5-9**Optimizing Print Speed and Image Band Setting 5-10***6**

---

**Using Test and Service Mode****Using Test and Service Mode Procedures 6-3***Printing Test Labels 6-5**Using Data Line Print 6-5**Resetting the Memory on Your Printer 6-6***Setting Configuration Commands in Test and Service Mode 6-6***Setting the Number of Dot Increments 6-7**Adjusting the Label Rest Point 6-9**Setting Emulation Mode 6-11**Using Forms Adjust 6-12**X Forms Adjust 6-13**Y Forms Adjust 6-14***A**

---

**Specifications****Printer Specifications A-3***Electrical Requirements A-3**Printing Method A-3**Environment A-3**Self-Strip (optional) A-3**Communications A-3**Specifications A-3**Dimensions (no options installed) A-3**Printhead A-4**Ribbon A-4**Printing Speed A-4**Fonts and Graphics A-4**Character Sets A-4**Media A-5*

**Printer Options A-6**

- Communication Interface A-6*
  - EasyLAN 10i Interface A-6*
  - Twinax Interface A-6*
  - Coax Interface A-6*
- Finishers A-6*
  - Cutter A-6*
  - Batch Takeup A-6*
  - Self-Strip Printing A-6*

**Bar Code Symbologies Supported A-8**

- 2D Symbologies A-9*
  - 2D Stacked Symbologies A-9*
  - 2D Matrix Symbologies A-9*

---

**B**

**Character Sets**

**International Character Sets B-3**

- Advanced Character Table B-3*
- Emulation Mode Character Table B-4*
- IBM Translation Character Table B-4*
- Code Page 850 Character Table B-5*

**Extended Character Sets B-6**

---

**C**

**Communications Reference**

**Communication Protocols C-3**

- Intermec Standard Protocol C-3*
- XON/XOFF Protocol (Software and Hardware Flow Control) C-4*
- XON/XOFF, No Status Protocol C-5*
- Polling Mode D C-5*
- Multi-Drop Protocol C-5*
- User-Defined Protocol C-5*
- Host Requirements C-7*
- Communications Boundaries C-7*

**Communications Interfaces C-7**

- RS-232 Serial Interface C-7*
- RS-422 Serial Interface C-8*
- RS-485 Serial Interface C-8*

**Printer Serial Port C-11**



---

## ***Full ASCII Table***

*Full ASCII Table D-3*

*Full ASCII Control Characters Table D-5*



---

## ***Glossary***



---

## ***Index***





## **Before You Begin**

---

This section introduces you to standard warranty provisions, safety precautions, warnings and cautions, document formatting conventions, and sources of additional product information. A documentation roadmap is also provided to guide you in finding the appropriate information.

---

### **Warranty Information**

To receive a copy of the standard warranty provision for this product, contact your local Intermec sales organization. In the U.S. call 1-800-755-5505, and in Canada call 1-800-668-7043. Otherwise, refer to the Worldwide Sales & Service list that was shipped with this manual for the address and telephone number of your Intermec sales organization.

---

### **Safety Summary**

Your safety is extremely important. Read and follow all warnings and cautions in this book before handling and operating Intermec equipment. You can be seriously injured, and equipment and data can be damaged if you do not follow the safety warnings and cautions.

**Do not repair or adjust alone** Do not repair or adjust energized equipment alone under any circumstances. Someone capable of providing first aid must always be present for your safety.

**First aid** Always obtain first aid or medical attention immediately after an injury. Never neglect an injury, no matter how slight it seems.

**Resuscitation** Begin resuscitation immediately if someone is injured and stops breathing. Any delay could result in death. To work on or near high voltage, you should be familiar with approved industrial first aid methods.

**Energized equipment** Never work on energized equipment unless authorized by a responsible authority. Energized electrical equipment is dangerous. Electrical shock from energized equipment can cause death. If you must perform authorized emergency work on energized equipment, be sure that you comply strictly with approved safety regulations.

---

## **Warnings and Cautions**

The warnings and cautions in this manual use the following format.



### **Warning**

*A warning warns you of an operating procedure, practice, condition, or statement that must be strictly observed to avoid death or serious injury to the persons working on the equipment.*

### **Avertissement**

*Un avertissement vous alerte d'une procédure de fonctionnement, d'une méthode, d'un état ou d'un rapport qui doit être strictement respecté pour éviter l'occurrence de mort ou de blessures graves aux personnes manipulant l'équipement.*



### **Caution**

*A caution alerts you to an operating procedure, practice, condition, or statement that must be strictly observed to prevent equipment damage or destruction, or corruption, or loss of data.*

### **Conseil**

*Une précaution vous avertit d'une procédure de fonctionnement, d'une méthode, d'un état ou d'un rapport qui doit être strictement respecté pour empêcher l'endommagement ou la destruction de l'équipement, ou l'altération ou la perte de données.*



---

## **About This Manual**

Analysts and programmers should use this manual to learn how to operate, program, and connect the EasyCoder® 3400e printer to a network or system. The first part of this manual tells you how to install, operate, maintain, and troubleshoot your printer. The last part of the manual covers advanced features of the 3400e printer. A basic understanding of DOS, programming, and data communications is necessary.

## **What You Will Find in This Manual**

This table summarizes the information in each chapter of this manual:

<b>For Information On</b>	<b>Refer To</b>
Installing the printer	Chapter 1, "Getting Started." Tells you how to plug in the printer, load fanfold media, configure the serial port, and print a configuration test label.
Operating the printer	Chapter 2, "Operating the Printer." Explains the printer front panel, tells you how to load roll media, load ribbon, test for communications, and download fonts.
Routine maintenance	Chapter 3, "Maintaining the Printer." Shows how to maintain the printer.
Troubleshooting	Chapter 4, "Troubleshooting." Instructs how to clear error messages and troubleshoot programming or configuration problems.
Improving printer performance	Chapter 5, "Optimizing Printer Performance." Tells you how to fine-tune the printer to increase processing time.
Test and Service features	Chapter 6, "Using Test and Service Mode." Provides information on using Test and Service mode to print test labels, perform Test and Service mode procedures, and configure DIP switch settings.
Specifications	Appendix A.
Character sets	Appendix B.
Communications	Appendix C.
Full ASCII chart	Appendix D.

## **Terms and Conventions**

Listed below are special terms and conventions used throughout the manual. Refer to the glossary for a complete list of terms found in this manual.

### **Terms**

“Printer” refers to a 3400e bar code label printer.

“Media” is the label stock on which the printer prints labels.

“Host” refers to a personal computer or other computer that communicates with the printer.

A “symbol” or “bar code symbol” consists of alphanumeric characters encoded in a bar code format.

### **Conventions**

The following conventions are used throughout this manual for operating procedures and descriptions of the printer.

- Feed/Pause refers to the Feed/Pause button on the printer front panel.
- Downloaded commands appear in the order that you enter them into the printer with the following conventions:

<b>Convention</b>	<b>Description</b>
< >	Angle brackets < > enclose mnemonic representations of ASCII control characters. For example, <ETX> represents the ASCII “End of Text” control character.
<i>data</i>	Italic text represents variable data, which you must replace with a real value. For example, <i>n</i> signifies a variable for which you must designate a constant value.
[ <i>data</i> ]	Italic text within brackets represents optional data.
<b>Ctrl</b>	Bold text represents a key on your keypad. For example, <b>Tab</b> represents the Tab key and <b>M</b> represents the letter M key.
<b>Ctrl-Z</b>	When two keys are joined with a dash, press them simultaneously. For example, if you see the command <b>Ctrl-C</b> , press the two keys at the same time.
E3 ; F3	Type all characters that appear in the Courier font by pressing an individual key on the keypad.



## ***Other Intermec Manuals***

---

You may need additional information when working with printers in a data collection system. Please visit our Web site at [www.intermec.com](http://www.intermec.com) to download many of our current manuals in PDF format. To order printed versions of the Intermec manuals, contact your local Intermec representative or distributor.





# ***Getting Started***





*This chapter introduces the EasyCoder® 3400e printer and explains how to get your new printer running for the first time.*

## ***Getting to Know Your Printer***

---

Features of your printer include:

- Support for direct thermal and thermal transfer printing applications. Chapters 1 and 2 explain how to load both types of media.
- An internal optional self-strip with integral liner takeup. See Chapter 2, “Operating the Printer,” for more information.
- An easy-to-use software application called PrintSet. PrintSet makes configuring your printer, downloading fonts and graphics, and printing a test label effortless.
- Minimal supervision and maintenance.
- Support for user-supplied fonts. You can easily download and print user-supplied fonts. See the PrintSet software application or the *IPL Programming Reference Manual* (Part No. 066396) for more information.
- Support for TrueType. You can easily download and print TrueType fonts. See the PrintSet software application or the *IPL Programming Reference Manual* for more information.
- e series—IEEE 1284 parallel port. Up to 8 ips (inches per second) print speed with selected media.

Use the following figures to familiarize yourself with your printer.

Front View

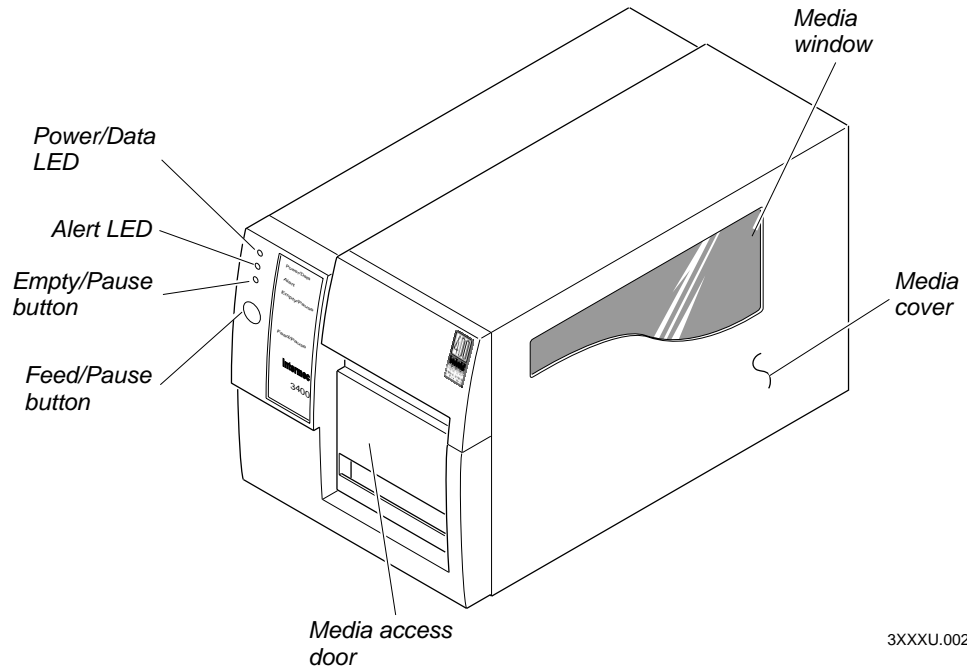

Back View

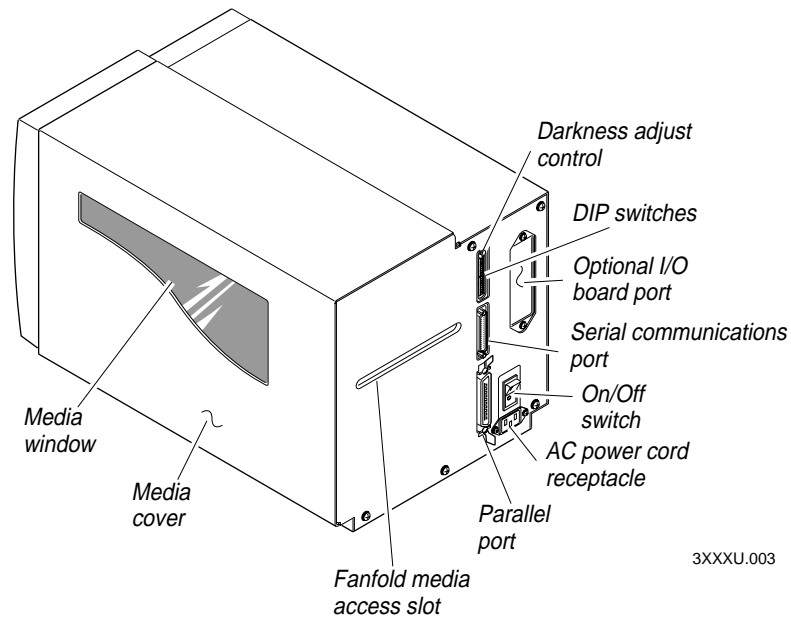

Several options are available for use with your printer. See Appendix A for complete descriptions of these options.

## Preparing the Printer for Installation

Before connecting your printer to your data collection system, you need to

- Plug in the printer.
- Open the printer and load media.
- Print a configuration test label.

### Plugging In the Printer

The back of your printer contains the AC power receptacle, the serial communications port, the On/Off switch, and two banks of DIP switches.

To plug in the printer

1. Turn the On/Off switch to the off position.
2. Make sure you set the DIP switches to their factory default settings.

**Top Bank** Set switch 1 on (I). Set switches 2 through 8 off (O).

**Bottom Bank** Set switches 1 through 8 off (O).

For a description of the DIP switch settings, see “Configuring the Serial Port for Communications” later in this chapter.

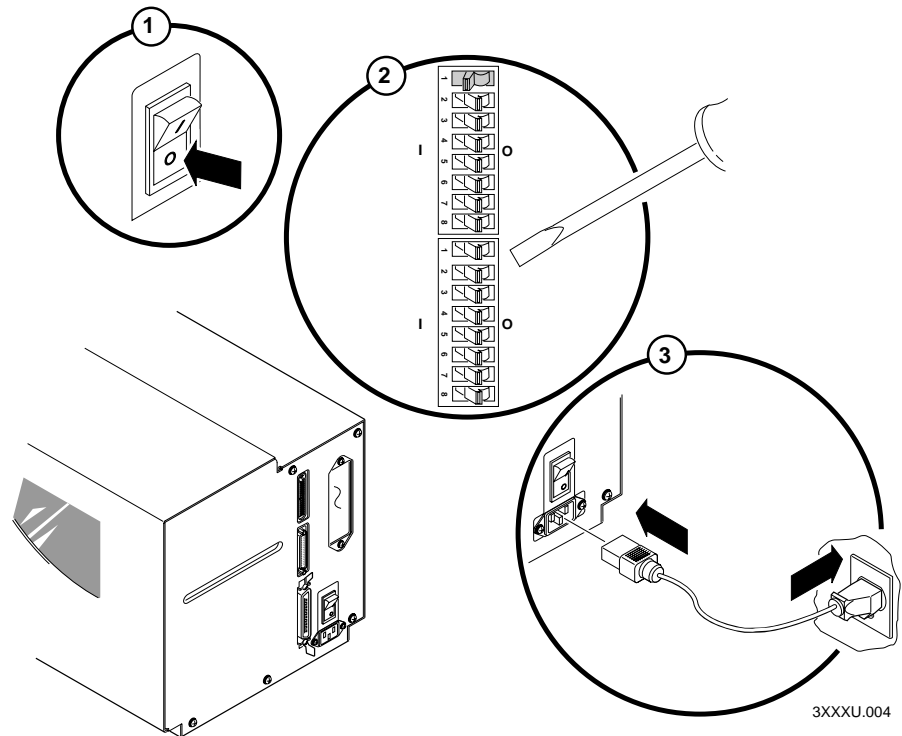

3XXXU.004

3. Plug the AC power cord into the receptacle at the rear of the printer. Plug the other end of the power cord into a grounded wall outlet or surge protector.
4. Turn the On/Off switch to the on position. When you power on the printer, the Power On LED lights, the Empty/Pause LED flashes, and the platen roller advances. The yellow Empty/Pause LED then stays on steady because you have not loaded media yet.

---

## **Opening the Printer**

You need to open the printer every time you load media or perform maintenance procedures.

### **To open the printer**

1. Place the fingers of your right hand between the two notches on the lower edge of the media cover (the media cover release) and pull the bottom of the media cover away from the base of the printer.
2. Grasp the front of the media cover with your left hand and lift the front of the media cover upward to release it from the printer frame.
3. Lift the media cover away from the top of the printer.

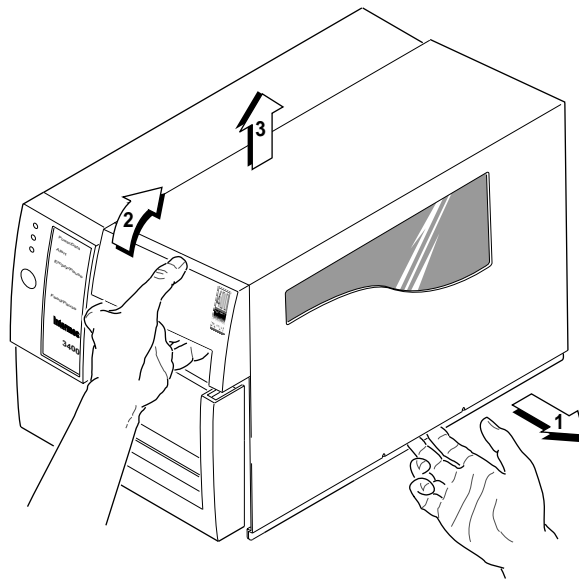

3XXXU.005

---

## **Loading Media for Fanfold Printing**

Use the sample of fanfold media provided in the Media Envelope to complete the following procedures. In fanfold printing, you place a stack of fanfold media at the rear of the printer and feed it into the printer through a slot in the rear cover. Refer to Chapter 2, “Operating the Printer,” for instructions on loading rolls of media.

### **To load media for fanfold printing**

1. Open the printer.
2. Disengage the printhead by rotating the head lift lever clockwise until it releases.
3. Move the supply roll retainer by turning it counterclockwise and sliding it to the outer end of the supply post.
4. Place the fanfold media slightly lower than the slot in the printer back cover. Line the (box of) fanfold media up with the label path through the printer. Insert media through the slot at the rear of the printer and thread it over the supply roll post.
5. To allow easy access to the media path, pull down on the lower media guide. Make sure that the edge guide is slid all the way to the outer edge of the edge guide plate.
6. Insert the fanfold media through the printer mechanism as shown in the illustration on the next page. The front edge of the media should pass over the tear bar and through the label dispense opening in the media cover. The fanfold media should pass over the supply roll post.
7. Release the lower media guide and adjust the edge guide to position the media firmly against the inside wall of the printer.
8. Slide the supply roll retainer up to the edge of the fanfold media and turn the supply roll retainer clockwise until it locks firmly in place securing the media against the inside wall of the printer.
9. Engage the printhead by rotating the head lift lever counterclockwise until it locks.
10. Close the printer by reversing the directions for removing the cover.

---

Loading Media for Fanfold Printing

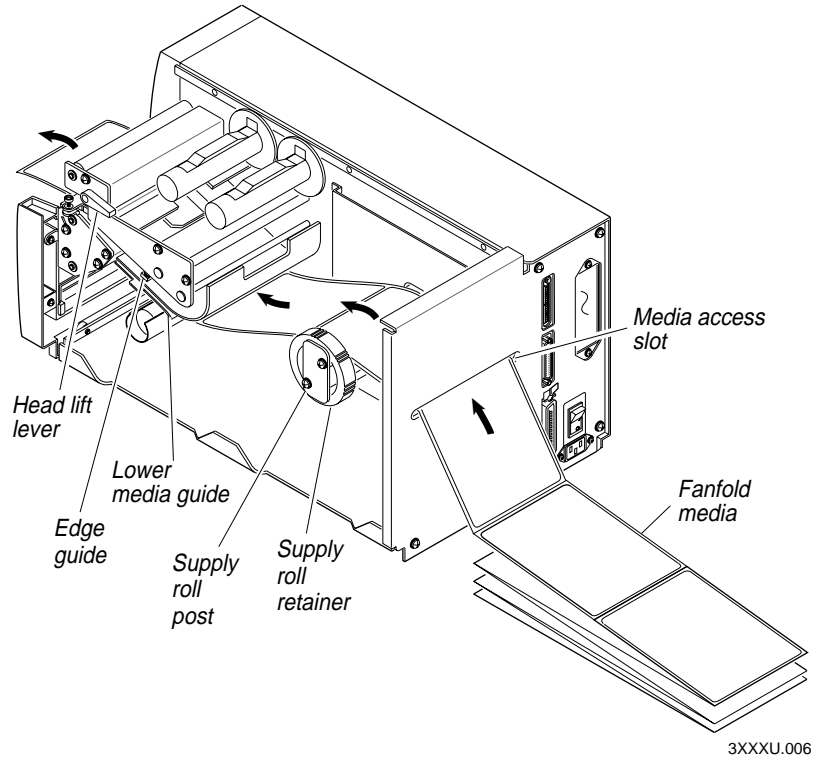

11. Press Feed/Pause to advance one label through the printer and out the label opening in the front cover. The printer is now ready to print the configuration test label. The yellow Empty/Pause LED goes out.



**Note:** If the yellow Empty/Pause LED does not go out, press Feed/Pause a second time and then reload the media and try again if the Empty/Pause LED still does not go out.



**Note:** For your convenience, refer to the label with directions for loading media. This label is located on the inside of the media cover.

---

## Printing the Hardware Configuration Test Label

You can print the hardware configuration test label to test the printer and make sure it is operating correctly. The hardware configuration test label lists the printer's configuration. Use this label for reference when installing your printer and for verification of proper printer operation.

### To print the hardware configuration test label

1. Turn the On/Off switch to the off position.
2. Press and hold the Feed/Pause button while you turn the On/Off switch to the on position. The Alert and Empty/Pause LEDs blink during the printer self-test.
3. Release the Feed/Pause button when the media starts moving. The printer feeds out one or two blank labels and then prints the hardware configuration test label.
4. Turn the printer power off and then on. You are now ready to connect your 3400e printer to your system.

---

### Hardware Configuration Test Label

3400e400 Hardware Configuration	
Memory Installed	
Flash Storage	: 128 kilobytes
Image RAM	: 805 kilobytes
Flash SIMM	: OKB
Mileage	
Inches Processed	: 0
Inches Burned	: 0
Labels Cut	: 0
Printhead	
Width	: 1792
Dot Size	: 2.5
Burn Pot Setting	: 141
Hardware Options	
I/O Option	: none
Internal Option	: none
External Option	: Cutter
Firmware Checksum	
ROM0 (U21)	: 95D0
ROM1 (U9)	: 7331
Program	: 067097
Version	: 2.0

3XXXU.007



**Note:** This is only an example of a hardware configuration label. Your label may not be exactly the same.

### **What the Hardware Configuration Test Label Tells You**

The hardware test label provides these statistics:

- Amount of installed memory
- Amount of media printed
- Printhead configuration
- Firmware information
- Printhead alignment (the vertical lines)

### **If a Hardware Configuration Test Label Does Not Print**

If you are unable to print a hardware configuration test label, see “Printer Operation Problems” in Chapter 4.

## **Connecting the Printer to Your System**

---

You can connect your printer to a PC, a local area network, an AS/400 (or other midrange computer), or a mainframe. This section tells you how to connect your printer to any of these systems.

This illustration shows you where to connect your system to the printer. You can use any of these three ports on the rear of the printer:

- Serial communications port
- Parallel port
- I/O board port (if you have an adapter card installed)

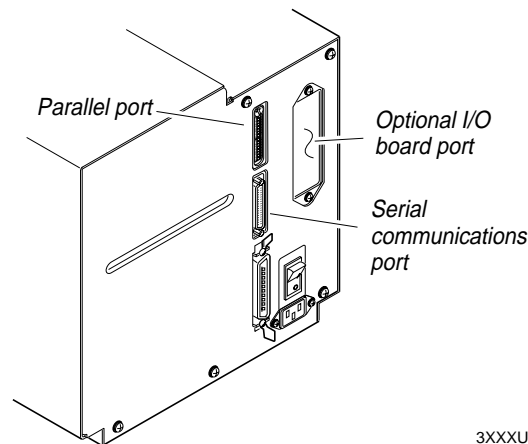

3XXXU.008



## Connecting Your Printer to a PC

You can connect your printer to either a serial port or parallel port on your PC. You must provide the correct cables for connecting the printer. See the following sections for cable information. Contact your Intermec representative for ordering assistance if you do not have the appropriate cables.

### Connecting the Printer to a PC Serial Port

To connect the printer to your PC serial port, you need a shielded EIA RS-232, RS-422, or RS-485 electrical interface with a 25-pin D-style subminiature connector. It must have pins on the printer end and an appropriate serial port connector on the other end.

Use the following table to determine the correct Intermec cable for your application. You cannot order an Intermec cable for the RS-422 interface, but there is a schematic in Appendix C that you can use to purchase or make your own cable. Also see Appendix C for the RS-232, RS-422, and RS-485 serial port pin assignments.

For Connecting To	Use Intermec Cable Part Number
IBM PC	048668 (25-pin printer to 25-pin serial port null modem)
IBM PC	048693 (25-pin printer to 9-pin serial port null modem)

### To connect your printer to a PC serial port

1. Turn the On/Off switch to the off position.
2. Plug the 25-pin connector into the serial communications port on the rear of the printer.
3. Plug the other end of the cable into a serial (COM) port on the PC.
4. If necessary, change the PC serial port configuration to match your printer. See "Configuring the Serial Port for Communications" later in this chapter for more information.

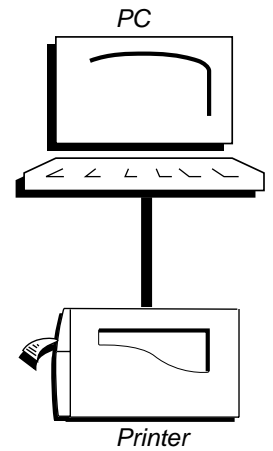

3XXXU.009

### ***Connecting the Printer to a PC Parallel Port***

If you are using a parallel port to communicate with your printer, you need a parallel cable to run between the printer and the PC.

You can purchase a parallel cable from Intermec (Part No. 051211) or from your local computer store. See Appendix A for pin descriptions of the parallel cable connector.

#### **To connect your printer to a PC parallel port**

1. Turn the On/Off switch to the off position.
2. Plug the parallel interface connector into the parallel communications port on the rear of the printer.
3. Plug the other end of the cable into a parallel port on the PC.

---

### ***Connecting Your Printer to a Network***

You can connect the printer to Novell NetWare networks, Token Ring networks, or other TCP/IP networks. To connect the printer to a network, you must have a network interface adapter (for example, Ethernet).

A field service technician can install the field installable option (Part No. 056830) in the optional I/O board port of your printer.

---

## Connecting Your Printer to a Network

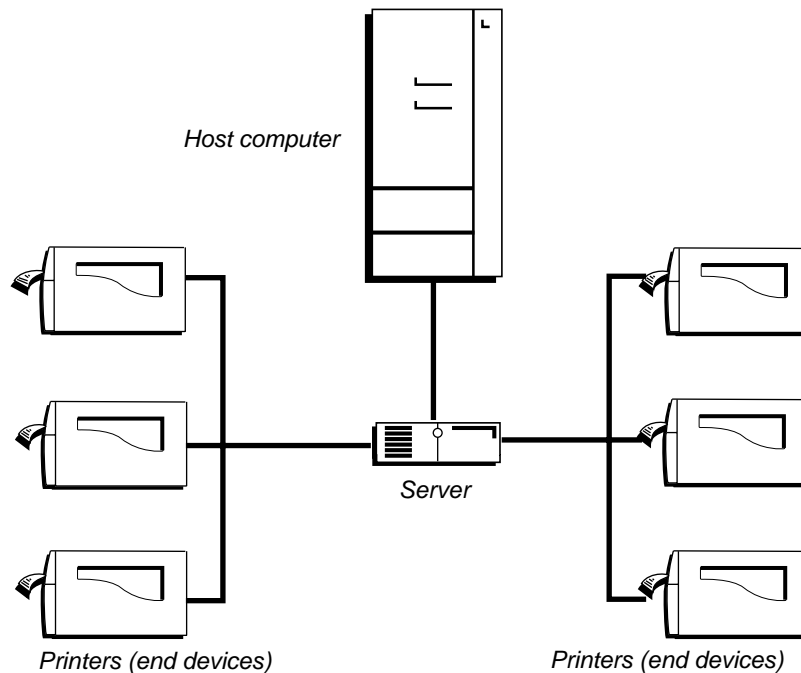

3XXU.019

The network interface adapter (for example, Ethernet) connects to the 10i port of the printer. Your network must be able to use XON/XOFF (software and hardware flow control) protocol. You may need to change the serial port settings to match the requirements of your network. You can determine the communications requirements for your network by referring to the controlling device documentation.

If the controlling device is an Intermec product, refer to the following manuals for instructions and information on the necessary cabling and connections.

If you need to change the printer's communications parameters, follow the procedures in "Configuring the Serial Port for Communications" later in this chapter.

---

## Connecting the Printer to an AS/400

To connect a printer directly to an AS/400 or other midrange computer, you need

- a twinax adapter card.
- a twinaxial cable equivalent to IBM part number 7362267 or 7362062. The maximum cable length for the twinax interface is 1,525 meters (5,000 feet).

If you did not have the twinax card installed at the factory, a field service technician can install the field installable option (Part No. 056835) in the optional I/O board port of your printer.

For help on cabling and communications, see the manual that comes with the twinax adapter card.



**Note:** If you are using a midrange computer other than the AS/400, refer to your system documentation for information on cabling and setting up communications.

---

## ***Connecting the Printer to a Mainframe***

To connect the printer directly to an IBM mainframe, you need

- a coax adapter card.
- a coaxial cable equivalent to IBM part number 2577672 or 1833108.

The maximum cable length allowed is 1,500 meters (4,920 feet). See the IBM specification *Installation and Assembly of Coaxial Cable and Accessories*, part number GA27-2805-4, for further information.

If you did not have the coax card installed at the factory, a field service technician can install the field installable option (Part No. 056836) in the I/O board port of your printer.

For help on cabling and communications, see the manual that comes with your coax adapter card.

---

## ***Cabling in Noisy Electrical Environments***

The items listed below create noisy electrical environments that can disrupt data communications between your host computer and the printer:

- Large power transformers
- Large electrical motors
- Arc welders
- Motor controllers
- Switch gears

If any of these items are near your printer, you may want to try the following suggestions to reduce the effects of electrical noise. If you need help eliminating noise, ask your Intermec representative for assistance.

- Always use shielded cable. Connect the cable and shield to the metal backshells on the cable connectors and fasten the connectors to the serial ports using screws.
- Install ferrite cable clamps.
- Connect the printer chassis ground to the building ground. You will find the chassis ground on the ground pin of the printer power cord.

## ***Configuring the Serial Port for Communications***

---

You need to configure the serial port of the printer to match the configuration of your PC or network controlling device. If the printer's default settings do not match, use the DIP switch settings table to configure the serial port.

### **To configure the printer serial port**

1. Use the following DIP switch setting descriptions and table to locate the DIP switches you need to change to configure the serial port.
2. Use a small straight-slot screwdriver to set the appropriate DIP switches.  
For example, if you want to change the media type to thermal transfer, set DIP switch 8 on the bottom bank of switches to the on position.
3. Turn the printer power off and then on for the configuration changes to take effect.



**Note:** Ignore Multi-Drop switches if you are not using a Multi-Drop network.

---

### ***DIP Switch Setting Descriptions***

<b>Parameter</b>	<b>Description</b>
Baud rate	The rate, in bits per second, at which the host exchanges data with the printer. The maximum baud rate is 115,200.
Parity	Adds one bit (1 or 0) to the character to make the sum of bits always odd or even.
Data bits	The number of bits that represent the ASCII characters.
Stop bits	Timing units between characters that synchronize character transmission.
Multi-Drop address	Unique address for each device connected with Multi-Drop protocol.
Protocol	The transmission standards for communication between the printer and each connecting device.
Media type	Enables the printer to work with either direct thermal or thermal transfer media.



## ***Verifying Printer Communications With Your System***

---

After connecting the printer to your system, you need to test communications. The easiest way to test communications is to set the printer to Data Line Print mode, which is part of Test and Service mode, and send a character string down from your system.

If you have just printed a configuration test label, you are already in Data Line Print mode. Start the following procedure with Step 4.

### **To verify communications with your system**

1. Turn the On/Off switch to the off position.
2. Press and hold the Feed/Pause button while you turn the On/Off switch to the on position. The printer prints the hardware configuration test label.
3. Release the Feed/Pause button. You are now in Data Line Print mode.
4. Transmit at least four characters from your system.

At this point, the printer does not attempt to interpret any printer commands, but simply prints each character with its hexadecimal equivalent underneath.



**Note:** An example of using DOS to verify printer communications follows this procedure.

5. To enter normal Print mode, turn the printer power off and then on again.

If this procedure does not work, make sure that the DIP switches match the serial port configuration of the system and that you have the printer cable securely plugged into the correct port of your system.

If you receive a write fault error, your cabling may not be correct. See “Connecting the Printer to Your System” earlier in this chapter for more information.



**Note:** Please refer to your host computer user's manual and the *IPL Programming Reference Manual* for information on downloading commands.

*Example of Using DOS to Verify Printer Communications*

1. At the DOS prompt, type this command and press **Enter**:

```
MODE COM1 96,E,7,1,N
```

2. Type these command lines and press **Enter**:

```
COPY CON COM1  
ABCDEF^Z
```

where:

COPY CON COM1 has the PC copy the following information to the COM1 port.

ABCDEF are random characters entered at the host.

^Z (**Ctrl-Z**) **Enter** sends the information to the printer.

The printer will print these characters:

```
A B C D E F  
41 42 43 44 45 46
```

3XXU.021



**Note:** If you are using a different platform to communicate with your printer, please refer to your host computer user's manual and the *IPL Programming Reference Manual* for help downloading commands.



# 2

## ***Operating the Printer***



Use this chapter to understand how to use the printer front panel, load roll media and media for self-strip printing, set the media sensitivity number, and communicate with the printer.

## ***Learning How to Operate the Printer***

---

To operate the printer, you need to understand:

**Front panel** Explains how light emitting diodes (LEDs) help you monitor the status of the printer and the various tasks the Feed/Pause button performs.

**Loading media and ribbon** Explains how to load roll media, thermal transfer ribbon, and the procedure for using the self-strip option.

**Media sensitivity numbers** Explain how to optimize print quality and print speed.

**Communications with the printer** Explains different methods for transferring information from the host to the printer and from the printer to the host.

## ***Understanding the Front Panel***

---

Use this section to understand the function of the front panel LEDs and the Feed/Pause button.

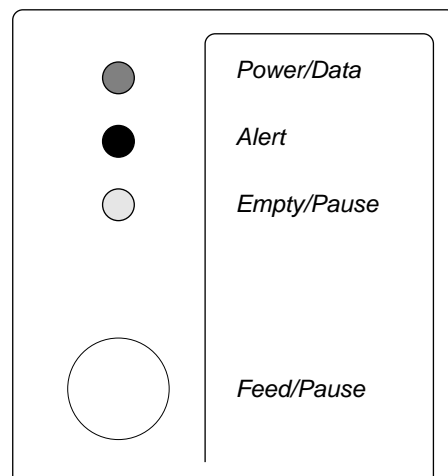

3XXXU.024

## Understanding the Front Panel LEDs

Use the front panel LEDs to monitor the status of the printer:

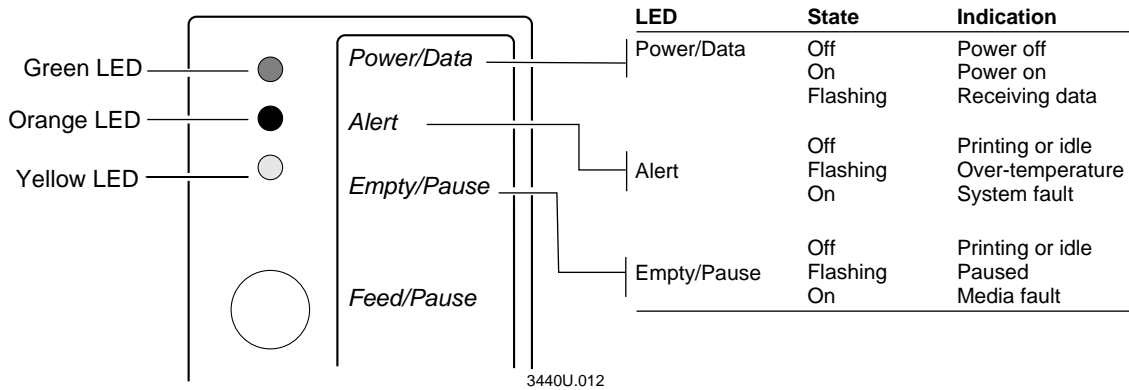

**Over-temperature** If the printer overheats, the Alert LED flashes and the printer stops. Do not try to troubleshoot or adjust the printer—just allow the printer enough time to cool down and it will resume operation on its own.

**Media or system faults** If the Empty/Pause or the Alert LED remains on, your printer is experiencing a media or system fault. For help, see Chapter 4, “Troubleshooting.”

---

## **Using the Feed/Pause Button**

The Feed/Pause button, located on the front of the printer, performs these functions depending on the mode of the printer:

<b>Printer Mode</b>	<b>You Want To</b>	<b>What to Do</b>
Idle	Feed out one label or a minimum specified amount of media.	Press and release the Feed/Pause button.
	Continuously feed media.	Press and hold the Feed/Pause button. When you release the button, the media stops feeding.
	Take the printer offline.	Press the Feed/Pause button twice. Press the button again to bring the printer online.
Printing	Pause the printer.	Press and release the Feed/Pause button. Press and release the button again to resume printing.
	Cancel the current print job.	Press and hold the Feed/Pause button until the printer stops printing.
Powered on for the first time	Print the hardware configuration label.	Press and hold the Feed/Pause button. See "Printing the Hardware Configuration Test Label" in Chapter 1 for more information.

## Loading Media Into the Printer

---

You can load media into the printer in three different ways:

- Straight-through printing with roll media
- Self-strip printing with roll media (optional)
- Fanfold printing (see Chapter 1)

You can load media with the printer power turned on or off. The following procedures for loading media assume that you have turned the printer on.

---

### Loading Roll Media for Straight-Through Printing

In straight-through printing, you load a roll of media on the supply roll post and feed it straight through the printer mechanism and out the front of the printer. As the printer completes the printing of individual labels, you can remove them from the roll by pulling them down across the tear bar.



**Note:** This procedure covers how to load media for straight-through print mode using a roll of direct thermal or thermal transfer label media. The default setting for the printer is direct thermal mode; use PrintSet to change the printer to thermal transfer mode.



**Note:** You should find a small label with a three-digit sensitivity number printed on it attached to your roll of media or a 15-digit number stamped on the side of the media roll (Intermec media only). Save this information. You will need it to set the correct media sensitivity number. See “Setting the Media Sensitivity Number” later in this chapter for help.

#### To load the media

1. Raise the printhead by rotating the head lift lever clockwise until the printhead disengages.
2. Turn the supply roll retainer counterclockwise to release it and then slide it to the outer end of the supply roll post.



**Note:** If you are replacing the empty media roll with a new roll of the same width, you do not need to adjust the edge guide or the supply roll retainer.

3. Place the media roll on the supply roll post and position it firmly against the printer.



**Note:** If you are using a narrow roll of media [less than 7.62 centimeters (3 inches)], insert the media support between the roll of media and the supply roll retainer before securing it.

### Loading Roll Media for Straight-Through Printing

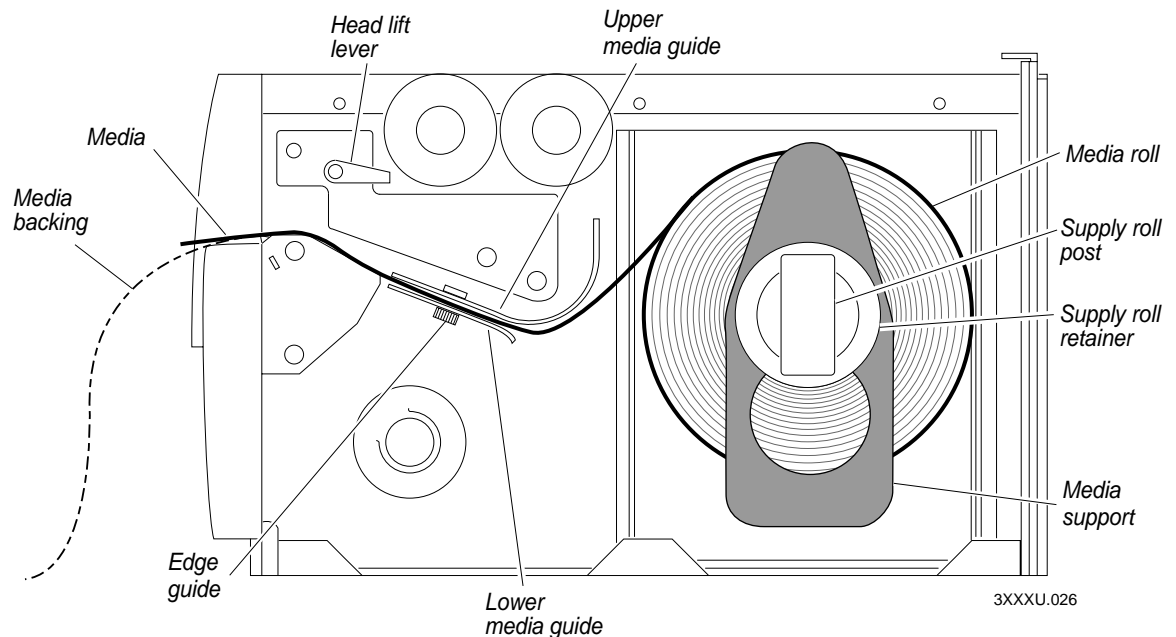

4. Slide the supply roll retainer up to the edge of the media roll and turn the supply roll retainer clockwise to secure.
5. Pull down on the lower media guide to allow easy access to the media path. Make sure that the edge guide slides all the way to the outer edge of the lower media guide.
6. Insert the label stock through the printer mechanism as shown. Make sure the label passes between the upper and lower media guides. The front edge of the media should pass over the tear bar and out the front of the printer.
7. Release the lower media guide and adjust the edge guide to position the media firmly against the inside wall of the printer.



**Note:** If you are using thermal transfer media, refer to “Loading Thermal Transfer Ribbon” later in this chapter before you finish performing this procedure.

8. Lower the printhead by rotating the head lift lever counterclockwise until it locks.
9. Use PrintSet, your third-party software, or the IPL command set to configure the printer for the kind of media you are using (continuous or mark label). Refer to the PrintSet online help, your third-party documentation, or the *IPL Programming Reference Manual* for help.
10. Press Feed/Pause to advance several inches of media through the printer and out the label opening in the front cover. Your printer is now ready to print labels.



**Note:** Refer to the label located on the inside of the media cover for directions on loading media. For your convenience, you may want to refer to it when loading media in the future.

---

## **Loading Media for Self-Strip Printing**

Use self-strip printing in applications where you want to apply labels to a surface immediately. After printing a label, the printer prints out the label with the backing removed. The rewinder hub collects the backing after it passes over the self-strip assist roller. The rewinder hub can hold the backing from an entire roll of media.



**Note:** You should find a small label with a three-digit sensitivity number printed on it attached to your roll of media or a 15-digit number stamped on the side of the media roll. Save this information. You will need it to set the correct media sensitivity number. See “Setting the Media Sensitivity Number” later in this chapter for help.

### **To load self-strip media**

1. Raise the printhead by rotating the head lift lever clockwise until the printhead disengages.
2. Turn the supply roll retainer counterclockwise to release it and slide it to the outer end of the supply roll post. Turn it clockwise to lock it in place.
3. Place the media roll on the supply roll post and position it firmly against the inside wall of the printer.
4. Turn the supply roll retainer counterclockwise and slide it up to the edge of the media roll. Turn the supply roll retainer clockwise to secure.



**Note:** If you are using a narrow roll of media [less than 7.62 centimeters (3 inches)], insert the media support between the roll of media and the supply roll retainer before securing it.



## Loading Media for Self-Strip Printing

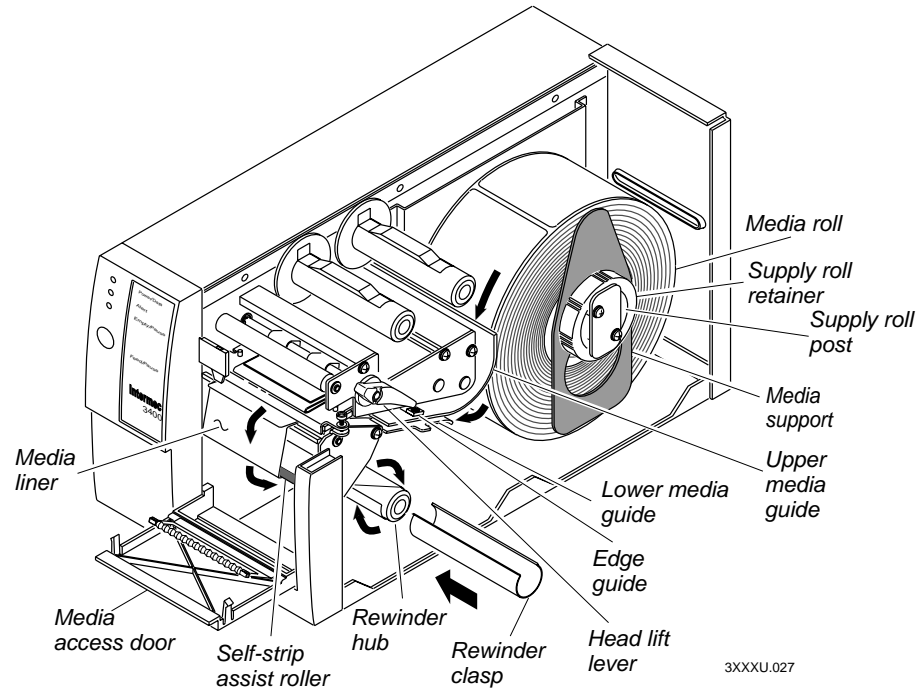

5. Unscrew the edge guide and slide it to the outer edge of the lower media guide. Screw it in place.



**Note:** If you are replacing the empty media roll with a new roll of the same width, you do not need to adjust the edge guide.

6. Pull down on the lower media guide to allow easy access to the media path.
7. Unroll several inches of media, insert it between the upper media guide and the lower media guide, and out the front of the printer.
8. Release the lower media guide and adjust the edge guide to position the media firmly against the inside wall of the printer.
9. Pull out 25.4 to 30.48 centimeters (10 to 12 inches) of media and remove the exposed labels from the media liner.
10. Open the media access door and thread the media liner under the self-strip assist roller and over the rewriter hub in a clockwise direction.
11. Remove the clasp from the rewriter hub and wind approximately 5.08 centimeters (2 inches) of media liner clockwise over the rewriter hub.

12. Secure the media to the rewinder hub by snapping the rewinder clasp onto the rewinder hub. Turn the rewinder hub clockwise to remove all slack from the media liner between the tear bar and the rewinder hub.
13. Close the media access door.
14. Rotate the head lift lever counterclockwise until it locks.
15. Use PrintSet, your third-party software, or the IPL command set to enable self-strip and the label taken sensor. Refer to the PrintSet online help, your third-party documentation, or the *IPL Programming Reference Manual* for help.
16. Press the Feed/Pause button to advance a label through the printer. Grasp the leading edge of the label where it has separated from the backing and pull it away from the printer.
17. Replace the printer cover. The printer is now ready to print labels.

## ***Loading Thermal Transfer Ribbon***

---

If you plan to use thermal transfer mode, you must install a thermal transfer ribbon (TTR) to print in thermal transfer mode.



**Note:** Save the packaging that your ribbon came in. Attached to the ribbon packaging is a small label with a three-digit sensitivity number printed on it (Intermec ribbon only). You need this information to set the correct media sensitivity number. Refer to the next section “Setting the Media Sensitivity Number” for more information.

### **To load thermal transfer ribbon**

1. Raise the printhead by rotating the head lift lever clockwise until the printhead disengages.
2. Place the empty ribbon core that came with the printer onto the ribbon rewind hub.
3. Detach the leader from the new thermal transfer ribbon roll and unwind the end of the ribbon approximately 20.32 centimeters (8 inches). The edge of the ribbon has a leader (with an adhesive strip on the leader edge) for guiding the ribbon through the printhead mechanism.
4. Slide the roll of thermal transfer ribbon onto the ribbon supply hub with the ribbon roll winding clockwise.

## Loading Thermal Transfer Ribbon

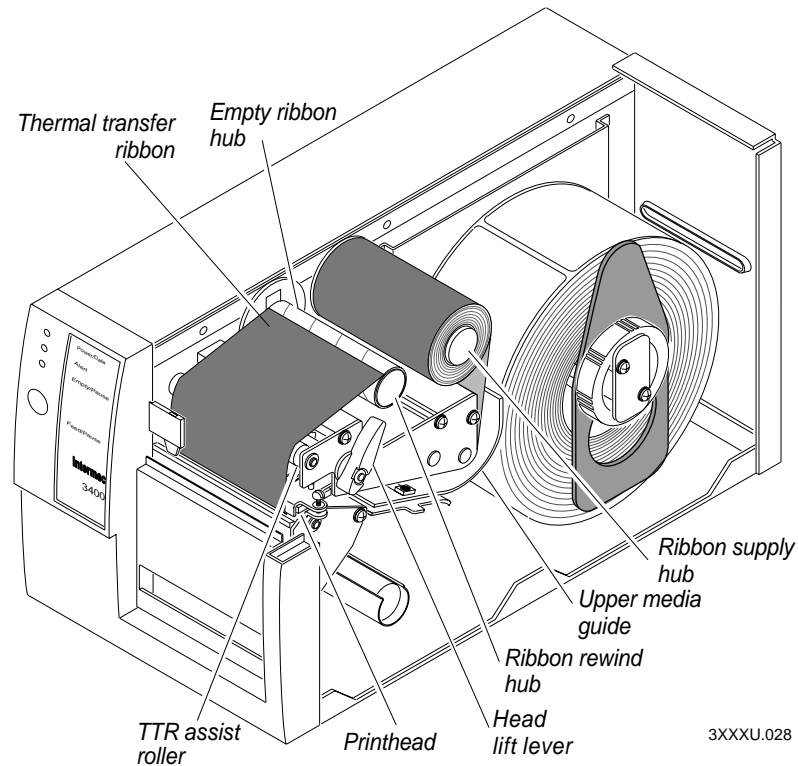

5. Route the ribbon leader through the printer mechanism as shown in the above illustration.



**Note:** Make sure the ribbon runs above the upper media guide. The shiny side of the ribbon must come in contact with the printhead.

6. Attach the leader from the new thermal transfer ribbon roll to the empty ribbon core using the adhesive strip on the leader edge.
7. Wind the ribbon rewind hub clockwise until the ribbon runs smoothly through the printhead mechanism and the leader moves past the printhead.
8. Rotate the head lift lever counterclockwise until it locks.
9. Enable thermal transfer printing by setting DIP switch 8 on the bottom bank of switches to the on position. For help, see “Configuring the Serial Port for Communications” in Chapter 1.
10. Press the Feed/Pause button to advance the ribbon through the printer.
11. Close the printer. The printer is now ready to print.



**Note:** When replacing the thermal transfer ribbon roll in the future, use the empty ribbon supply core as the new rewinder core.

## Setting the Media Sensitivity Number

Media sensitivity is important because you use it to optimize print quality and print speed. The three-digit media sensitivity number (MSN) specifies the amount of heat required by the printhead to image a label. The amount of heat that each roll of media or ribbon requires is unique due to different chemistries and manufacturing processes. Intermec has developed heating schedules (the amount of heat required to image a label) to produce the highest possible print quality for Intermec media and ribbon combinations on Intermec printers.

Look for the three-digit media sensitivity number on

- the side of the media roll. Use the last three digits (140 in the example) of the 15-digit number stamped on the roll for the media sensitivity number.
- a small label attached to the roll of media.
- a small label attached to the plastic bag of your ribbon roll. Your label may be different than this example, but it will contain the sensitivity number.

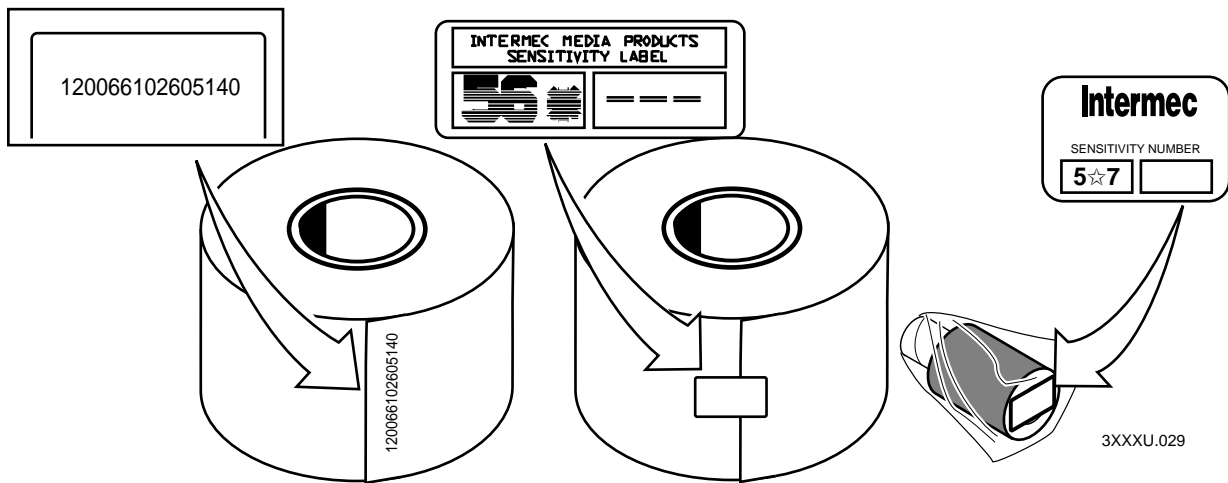

**Note:** Some ribbon rolls have the media sensitivity number printed on the inside core.

Use this three-digit number to optimize print quality and print speed on your printer. You can achieve the best print quality on the printer by using only Intermec ribbon and media products. The default sensitivity setting for thermal transfer media is 567. For direct thermal media, the default sensitivity setting is 470.

Use the PrintSet software, your third-party software, or the IPL command set to change the media sensitivity number. If you want to see the current sensitivity setting of your printer, print out a software configuration label.

**To print a software configuration label**

1. Turn the On/Off switch to the off position.
2. Press and hold the Feed/Pause button while turning the printer on. The printer prints out a hardware configuration label.
3. Set the DIP switches to print out the software test label.
  - Top Bank** Set switches 1 through 6 and 8 off. Set switch 7 on.
  - Bottom Bank** Set switches 1 through 8 off.
4. Hold the Feed/Pause button down for 1 second. The printer prints out the software configuration label.
5. Return the DIP switches to their original settings.
6. Turn the printer power off and then on.

---

***Setting the MSN for Intermec Media and Ribbon***

For direct thermal media, use the three-digit sensitivity number located on the roll of media to set the sensitivity number. You can also use the values from the tables in the next section.

For thermal transfer media, you need to look in two places to determine the sensitivity number. The sensitivity number on each roll of thermal transfer media or ribbon has an asterisk (\*) in place of one of the digits. On thermal transfer media, the rating contains the first and second digits, with an asterisk in place of the third digit. The number on the ribbon has the first and third digits, with an asterisk in place of the second digit.

To optimize the sensitivity number for thermal transfer media, you combine the digits as in this example.

Media or Ribbon	Sensitivity Number	Description
Thermal transfer media	56*	The asterisk reserves the third digit to identify the ribbon's sensitivity number.
Thermal transfer ribbon	5*7	The asterisk reserves the second digit to identify the media's sensitivity number.
	567	Optimized sensitivity number

---

## **Setting the MSN for Other Media and Ribbon**

If you are not using Intermec media and ribbon, or you misplaced your packaging with the three-digit sensitivity number label on it, you can set the approximate sensitivity number. The first column of the Direct Thermal and Thermal Transfer Media Sensitivity Settings tables list the approximate sensitivity settings. To achieve acceptable print quality, enter the three-digit media sensitivity number (for example, 800).

If you are unsure of how to set the media sensitivity number, start with the highest setting, which provides the lowest energy (800 for thermal transfer and 700 for direct thermal), and work your way down until you achieve the best print quality. You can also use PrintSet's Print Quality Wizard to help achieve print quality.

---

### **3400e Printer Direct Thermal Media Sensitivity Settings**

<b>Approximate Sensitivity Numbers</b>	<b>Sensitivity Setting</b>	<b>Direct Thermal Media</b>	<b>Maximum Recommended Print Speed</b>
700 Series High Sensitivity	720	Duratherm Lightning Plus - 2	8
	400 Series Medium Sensitivity	480	Duratherm Lightning IR Tag
	470	Duratherm Lightning - 1	5
	460	European IR	5
	450	Duratherm Lightning IR Labels - 1	5
	440	European Thermal	5
	420	Duratherm Lightning Labels - 1	5
100 Series Low Sensitivity	180	Duratherm II - 1	3
	170	European Tag	3
	160	Duratherm II Tag	3
	140	European Top	3
	130	Duratherm II - 2	3
800 Series High Sensitivity (Paper)	864	European Uncoated/Standard - 1	8
	854	Duratran TTR Paper Labels/Standard - 1	6
	834	Duratran TTR Paper Tags/Standard - 1	6
600 Series Medium Sensitivity (Paper)	687	Duratran TTR Polyester 1/Premium - 7	6
	677	Duratran Syntran/Premium - 7	6
	633	European Polyethelene/Premium	8
	627	Duratran Kimdura/Premium - 7	8
	623	Duratran Kimdura/Premium	6

**3400e Printer Thermal Transfer Media and Ribbon Sensitivity Settings (continued)**

Approximate Sensitivity Numbers	Sensitivity Setting	Direct Thermal Media	Maximum Recommended Print Speed
500 Series Medium Sensitivity (Paper)	567	Duratran II-1/Premium - 7	8
	565	European Premium Paper/Premium	4
	563	Duratran II-1/Premium	7
	533	European Tag/Premium	6
	527	Duratran II Tag - 7 mil/Premium - 7	6
	513	European Coated/Premium	6
300 Series Low Sensitivity (Plastic)	369	Super Premium Poly./Super Premium - 3	5
	366	Super Premium Poly./Super Premium - 7	5
200 Series Low Sensitivity (Kapton)	238	Gloss Polyimide (Kapton)/Gloss Super Premium	3
	236	Gloss Polyimide (Kapton)/Super Premium-7	3
	226	Matte Polyimide (Kapton)/Super Premium-7	3
	222	Matte Polyimide (Kapton)/Matte Super Premium	3

## **Communicating With the Printer**

---

You are now ready to print labels by downloading data from the host to the printer. *Downloading* is the universal term used to describe the transfer of information from the host to any connected peripheral device, such as your printer. When you transfer data from your printer to the PC or host, you are performing a process called *uploading*.

You can use several methods to download information in your data collection system. The next sections describe different ways to communicate with the printer.

---

### **Using the PrintSet Software**

Use the PrintSet application software to easily configure your printer from your PC. You can upload the current configuration settings, modify them, and then download them to your printer. PrintSet also lets you

- download graphics and fonts.
- print test labels using resident fonts, user-defined bitmap graphics, or resident bar code symbologies.
- allocate printer memory.
- download configuration files to multiple printers.
- use flash-based firmware (e series).

For help using PrintSet, refer to the online help portion of the application software.

---

### **Using Third-Party Software**

You can use third-party software to set many of the printer parameters. You can configure the parameters that your software does not set by using the printer command set or the configuration DIP switches.

Use your third-party software to create label formats and convert graphics into a user-defined character (UDC) format that the printer can interpret. Refer to your third-party documentation and the *IPL Programming Reference Manual* (Part No. 066396) for more information.

---

### **Using Intermec Printer Language (IPL) Commands**

You can create labels by downloading formats (designs) and data with IPL commands. You can use the printer to perform any function or activate any feature of the printer except for those features or functions that you set with the DIP switches. See the *IPL Programming Reference Manual* for more information.



---

## ***Printing a Test Label***

If you would like to test your communications by downloading a label, follow the example below. Use the PrintSet application software to send a test label to the printer. This example assumes that your printer is communicating with a PC and that the printer is correctly loaded with media.

### **To print the test label**

1. Start PrintSet on your PC.
2. From the Options menu, choose Test Print.
3. Select the Test Label option button.
4. Select either the Text or the Bar Code option button.

If you select to print text, you can choose any font in the Select Printer Font list box.

If you select to print a bar code, you can choose any symbology in the Select Symbology list box.

5. Choose Print. Your attached printer prints a test label.

For example, if you chose to print a bar code with the Code 39 symbology, your printer prints a label similar to this one:

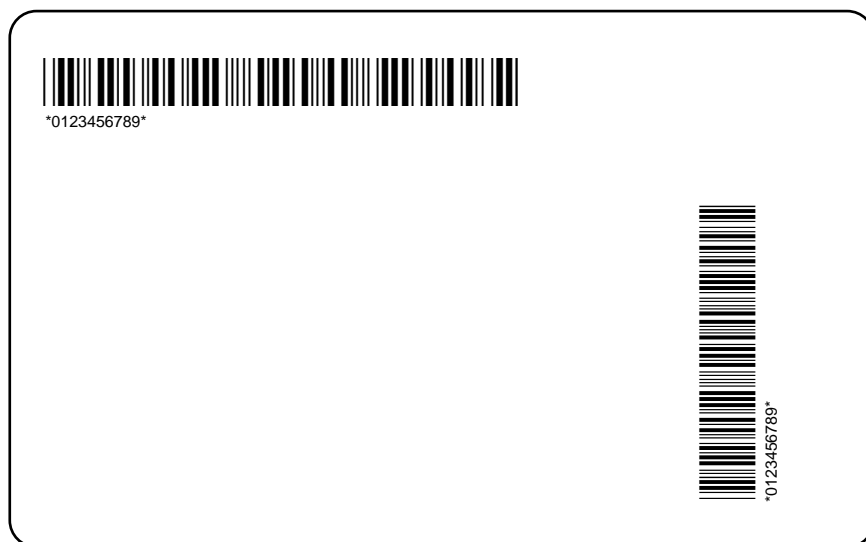

3XXU.030



# 3

## ***Maintaining the Printer***



*This chapter contains cleaning procedures and a schedule detailing how often to perform maintenance procedures. Even though the design of your printer enables it to withstand harsh environments, you must clean it on a regular basis to keep it running at its highest performance level.*

*It is very important to perform the maintenance procedures if you expose the printer to dirt or debris. For information on maintenance procedures such as replacing media or ribbon, see Chapter 1, "Getting Started," and Chapter 2, "Operating the Printer."*

## ***Inspecting the Printer***

---

Inspect the printer and the rest of your data collection system equipment on a regular basis. Your inspection should include the following:

- Make sure you have properly grounded the printer.
- Inspect the work environment. Large electric motors, welders, and switching equipment can affect printer performance.
- Keep the printer away from liquids.
- Check the data collection network regularly for loose wires or poorly installed connections. Be sure to replace corroded wires.

## ***Tools for Cleaning the Printer***

---

To clean the printer safely and effectively, use the following items:

- Isopropyl alcohol
- Cotton swabs
- Clean lint-free cloth
- Vacuum cleaner
- Soapy water/mild detergent
- Printhead cleaning pad (Part Number 1-110501-00)

The following procedures explain how to access the printer parts and clean them without causing any harm to the printer or yourself.

## Maintenance Schedule

---

Clean your printer regularly to maintain the quality of your labels and extend the life of your printer. This table contains suggestions for cleaning the printer. Use the illustration on the next page to locate the parts you need to clean.

Printer Component	Maintenance Period
Printhead	Inspect after every roll of media or ribbon. Clean after every roll [or 15,240 centimeters (6,000 inches)] of media or more often if necessary.
Printer Cover	Clean as necessary.
Drive roller and tear bar Media path (not shown) Edge guide Upper media guide Lower media guide Thermal transfer ribbon (TTR) assist roller Self-strip roller Label gap sensor (not shown) Label mark sensor (not shown) Label taken sensor Pinch roller	Clean after every five rolls of media. If you are using hi-tack adhesive, you must clean after every roll of media. If you are using tag stock or continuous media, you may want to clean after every five rolls of media or as necessary. Clean more often in environments that are harsh or dusty.

Locating the Printer Parts You Need to Maintain

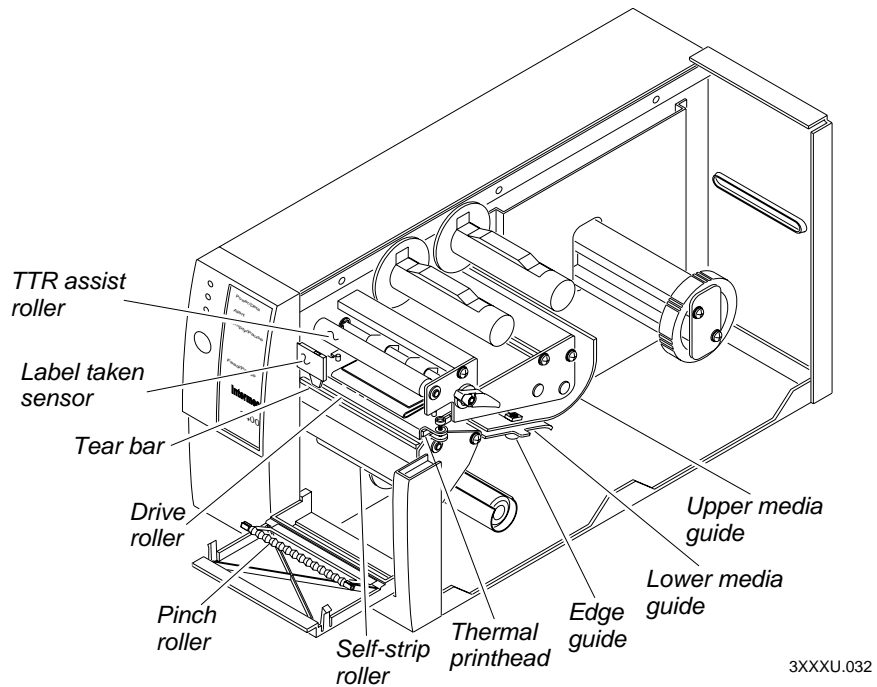

**Warning**

*Switch off the printer power and remove the power cord before cleaning any part of the printer.*

**Avertissement**

*Mettez l'imprimante hors tension et débranchez le câble d'alimentation avant de nettoyer une partie de l'imprimante.*

---

## ***Cleaning the Printhead***

In order for the printhead to provide good print quality, it must maintain close contact with the media. Therefore, cleaning media debris from the printhead is very important. Clean after every roll [or 15,240 centimeters (6,000 inches)] of media or when necessary.



### **Caution**

*Do not use sharp objects such as knives or screwdrivers to scrape the printhead clean. Cleaning with sharp objects will damage the printhead. Clean with only a cotton swab, or a clean, lint-free cloth or tissue damp with isopropyl alcohol.*

### **Conseil**

*N'utilisez pas d'objets pointus tels que couteaux ou tournevis pour nettoyer la tête d'imprimante. Nettoyer avec des objets pointus endommagera la tête d'imprimante. Nettoyez-la seulement avec de la ouate ou avec un linge propre et libre de peluches, humidifié avec de l'alcool d'isopropyl.*

### **To clean the printhead**

1. Turn the On/Off switch to the off position and remove the power cord.
2. Remove the media cover.
3. Rotate the head lift lever clockwise until the printhead releases. Rotating the head lift lever raises the printhead to allow for cleaning.
4. Remove the media and ribbon (if necessary).
5. Use a cotton swab moistened with alcohol to remove any dirt, adhesive, or debris from the print surface on the bottom of the printhead.
6. Wait 5 to 10 seconds for the print surface to dry. Replace the media and ribbon.
7. Engage the printhead by rotating the head lift lever counterclockwise until it locks in place.
8. If you are finished cleaning, replace the media cover.



---

### *Cleaning the Printhead*

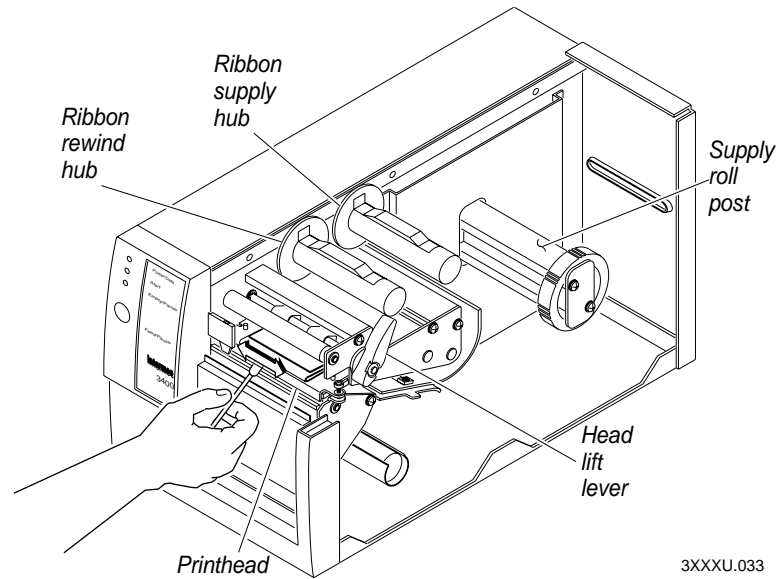

---

### ***Cleaning the Printer Covers***

Use a general purpose cleaner (soapy water/mild detergent) to clean the printer covers. Do not use abrasive cleansers or solvents. Be sure to clean the transparent panel on the media cover so that the media supply inside the printer is visible when you close the cover.

---

## ***Cleaning the Drive Roller and Tear Bar***

Cleaning the drive roller and tear bar preserves print quality by maintaining close contact between the media and the printhead.

### **To clean the drive roller and tear bar**

1. Turn the On/Off switch to the off position and remove the power cord.
2. Remove the media cover.
3. Rotate the head lift lever clockwise to release the printhead.
4. Remove the media and ribbon (if necessary).
5. Clean the drive roller by using a cloth dampened with isopropyl alcohol. Move the cloth over the drive roller in a side-to-side motion as shown. Make sure to rotate the roller so that you can clean all areas.



**Note:** Rotating the TTR assist roller toward you enables you to clean the entire drive roller surface.

6. Clean both sides of the tear bar with a cloth dampened with isopropyl alcohol. Remove all traces of dust, paper, and adhesive.
7. Replace the media and ribbon.
8. Engage the printhead by turning the head lift lever counterclockwise until the printhead locks.
9. If you are finished cleaning, replace the media cover.

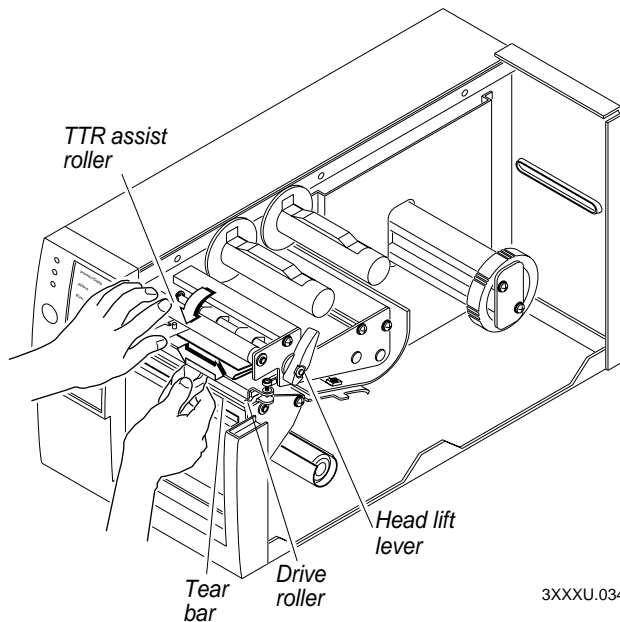

3XXXU.034

## ***Cleaning the Media Guides and Media Path***

You should clean the media guides and media path regularly to keep debris off the media surface and printhead where irregularities can spoil print quality or damage the printhead. Cleaning the guides also prevents the media from skewing or improperly tracking as it travels through the paper path which can result in smeared images and print off the side of the label. Always clean the media guides immediately after a label jam in the printer.

### **To clean the media guides and media path**

1. Turn the On/Off switch to the off position and remove the power cord.
2. Remove the media cover.
3. Remove the media and ribbon (if necessary).
4. Pull down on the lower media guide to open up the media path.
5. Use the cloth moistened with isopropyl alcohol to clean the upper and lower media guides. Be sure to remove all traces of debris. Release the lower media guide.
6. Remove all traces of dust, paper, and adhesive from the media path with a soft bristle brush or vacuum.
7. Replace the media and ribbon.
8. If you are finished cleaning, replace the media cover.

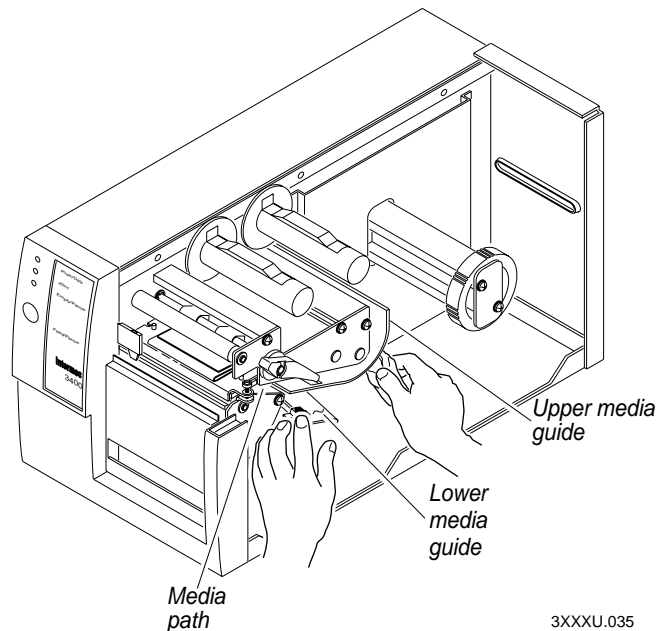

3XXXU.035

---

## ***Cleaning the Label Sensors***

Three label sensors on the printer require regular cleaning:

- Label taken sensor
- Label mark sensor
- Label gap sensor

### **To clean the label sensors**

1. Turn the On/Off switch to the off position and remove the power cord.
2. Remove the media cover.
3. Rotate the head lift lever clockwise to release the printhead. Rotating the head lift lever raises the printhead to allow access to the label mark sensor.
4. Remove the media and ribbon (if necessary).
5. Clean the label taken sensor with a cotton swab moistened with isopropyl alcohol.
6. Pull down on the lower media guide to expose the label gap sensor. Using a cleaning brush or vacuum, remove all debris and dust from the label gap sensor.
7. Clean the label gap sensor with a cotton swab and alcohol.
8. Replace the media and ribbon.
9. Engage the printhead by rotating the head lift lever counterclockwise until it locks in place.
10. Replace the media cover.

Cleaning the Label Sensors

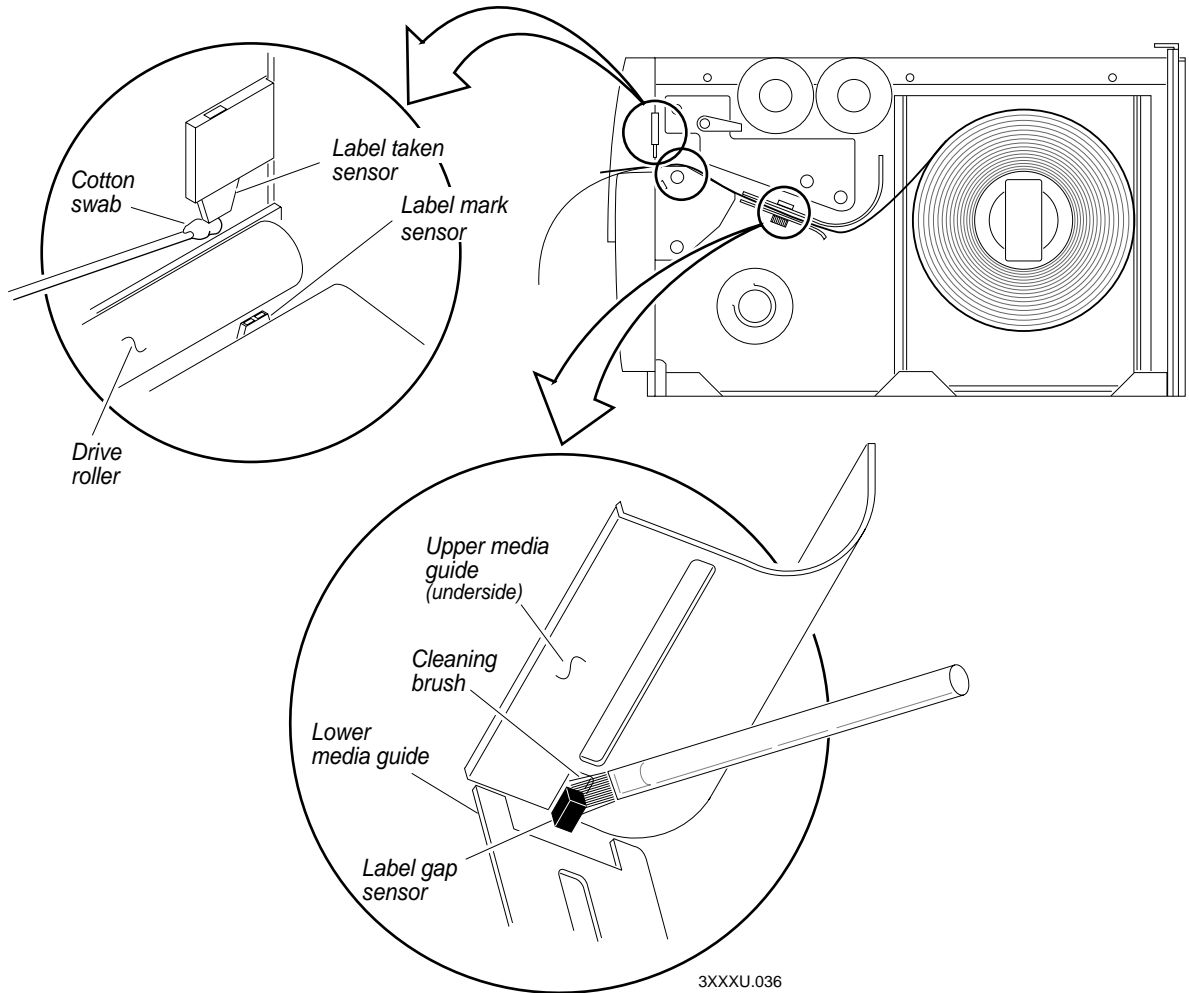





# ***Troubleshooting***





*This chapter provides some hints for troubleshooting error messages that the printer sends to the host and problems you may experience with the printer.*

## **Troubleshooting Checklist**

---

Even though Intermec designed your printer to operate under harsh conditions, you may still encounter a printer operation, print quality, or communication problem at some time. You can easily fix most of the errors you encounter and consequently not delay operation of the printer for very long.

### **To troubleshoot your printer**

1. First try cleaning the printer components and checking all of the connections. See Chapter 3, "Maintaining the Printer," for details.
2. If cleaning the printer and checking the connections does not solve the problem, use the following tables to locate the symptom. Follow the solution in the table to fix your problem.

If you receive an error message, refer to the *IPL Programming Reference Manual* (Intermec Part No. 066396) for a complete list of error messages and their solutions.

If the problem persists, contact your Intermec Customer Service Representative (1-800-755-5505) from North America. If you are an international customer, contact your local Intermec representative.

## **Printer Operation Problems**

---

If your printer is not operating correctly, try locating the problem in the table below:

Symptom	Possible Causes	Solution
No power or loss of power.	You have damaged or disconnected the AC power cable.	Make sure you have plugged the power cable into both the printer and an outlet or power strip. Replace the cable if damaged.
	Printer circuit breaker tripped.	Turn the printer off, then back on again.
Labels stop feeding through the printer.	Printer is out of media.	Load new media. Refer to Chapter 1, "Getting Started," or Chapter 2, "Operating the Printer."
	You have loaded the label stock incorrectly.	Check the media path. See Chapter 1, "Getting Started," or Chapter 2, "Operating the Printer."

---

**Printer Operation Problems (continued)**

<b>Symptom</b>	<b>Possible Causes</b>	<b>Solution</b>
Labels stop feeding through the printer. (continued)	You have set the printer for continuous label stock.	Use PrintSet to check the configuration settings. If the settings are incorrect, use PrintSet to change the settings.
	Media is sticking to the paper path.	Clean any extraneous material from the paper path and clean the path thoroughly. Refer to Chapter 3, "Maintaining the Printer."
Printer slows down.	You have incorrectly set the image bands or print speed.	Use PrintSet to change the image bands or print speed settings.
	Printer has aborted and reset the print speed and image bands.	Use PrintSet to change the image bands or print speed settings.
Labels stick to door or fail to strip.	The self-strip roller is dirty.	Clean the self-strip roller. See Chapter 3, "Maintaining the Printer."
The Alert LED flashes and printing stops.	Printhead has overheated.	Leave printer alone until it has time to cool down. It will resume printing on its own.
Media fault.	The printhead is up.	Make sure the printhead is down. The head lift lever should be straight up and down. Press the Feed/Pause button to resume printing.
	Sensor type set incorrectly.	Configure the printer for the correct sensor for the Print mode you are using. You can enable self-strip and other Print modes from PrintSet.
	You have incorrectly loaded the media.	Try reloading the media. For help, see "Loading Media Into the Printer" in Chapter 2.
Test configuration label does not print.	You have incorrectly loaded the media.	Try reloading the media. For help, see "Loading Media Into the Printer" in Chapter 2.
	You have configured the printer for self-strip media.	Set the printer to the default configuration using the DIP switches. For help, see "Plugging In the Printer" in Chapter 1.
	Media fault.	Remove media from under the label taken sensor.

**Printer Operation Problems (continued)**

Symptom	Possible Causes	Solution
Printer is not communicating, not printing, or not printing properly.	Corrupt or incorrect information in printer memory.	Reset the memory to return the printer to its default configuration. For help, see “Resetting the Memory on Your Printer” in Chapter 6. After you reset the memory, power off the printer and return the DIP switches to the required setting. For help, see “Configuring the Serial Port for Communications” in Chapter 1.

**Print Quality Problems**

If your labels are not printing properly, check the following table to locate the symptom and correct the problem.

Symptom	Possible Causes	Solution
Blotches printing on labels.	Dirty printhead.	Clean the printhead. For help, see “Cleaning the Printhead” in Chapter 3.
	Dirty media path or rollers.	Clean the media path. For help, see “Cleaning the Media Guides and Media Path” in Chapter 3.
	Poor quality label or ribbon stock.	Use only Intermec label and ribbon stock to ensure superior print quality and product performance.
Printing is too light or too dark.	Incorrect media sensitivity setting.	Change sensitivity setting to match the type of media you are using (for help, see “Setting the Media Sensitivity Number” in Chapter 2). If you set the sensitivity setting correctly, try changing the dark adjust.
	Incorrect darkness adjust control setting.	Adjust the knob to achieve the best print quality. For help, see “Adjusting the Print Darkness” in Chapter 5.
	Poor quality label or ribbon stock.	Use only Intermec label and ribbon stock to ensure superior print quality and product performance.
	Dirty printhead.	Clean the printhead. For help, see “Cleaning the Printhead” in Chapter 3.

---

**Print Quality Problems (continued)**

<b>Symptom</b>	<b>Possible Causes</b>	<b>Solution</b>
Printing not aligned on label.	Printer is misfeeding media.	Make sure you have correctly installed the media. For help, see "Loading Media Into the Printer" in Chapter 2.
Labels are not stopping at the right point for removal.	Incorrect label rest point setting.	Adjust the label rest point. For help, see your PrintSet online help or the <i>IPL Programming Reference Manual</i> .
	Incorrect label stock setting.	Set the printer to thermal transfer or direct thermal label stock. For help, see "Loading Media Into the Printer" in Chapter 2.
Print quality is poor.	Incorrect media sensitivity setting.	Change sensitivity setting to match the type of media you are using. If you set the sensitivity setting incorrectly, try changing the print darkness. For help, see your PrintSet online help or <i>the IPL Programming Reference Manual</i> .
	Incorrect darkness control setting.	Adjust the darkness adjust control. For help, see "Adjusting the Print Darkness" in Chapter 5.
	Print speed exceeds the capability of the media.	Lower your print speed or use Intermec media recommended for your print speed.
	Printhead, platen roller, or label path are dirty.	Clean printhead, platen roller, and label path as described in Chapter 3, "Maintaining the Printer."
	Uneven print contrast (density).	Adjust the bias adjust screw. See "Correcting Uneven Print Quality" in Chapter 5.
	Poor quality label or ribbon stock.	Use only Intermec label and ribbon stock to ensure superior print quality and product performance.
	Ribbon wrinkling.	Check to make sure that you installed the ribbon correctly. For help, see "Loading Thermal Transfer Ribbon" in Chapter 2. Set the bias adjust screw. See "Correcting Uneven Print Quality" in Chapter 5.
	Ribbon installed upside down.	Install ribbon with shiny side facing the printhead. See "Loading Thermal Transfer Ribbon" in Chapter 2.
Direct thermal/thermal transfer switch set in the wrong position.	Set the switch for the type of media you are using. For help, see "Loading Media Into the Printer" in Chapter 2.	

**Print Quality Problems (continued)**

Symptom	Possible Causes	Solution
Print quality is poor. (continued)	Media may be slipping against the platen roller causing the printing to compress.	Switch to approved media or clean the printhead and platen roller as described in Chapter 3, "Maintaining the Printer."
The printer skips labels randomly or sends an intermittent error.	The label format extends beyond the label length.	Edit the format to ensure that the text fits on the label.
Continuous empty/pause fault light (yellow LED).	The label mark sensor is not in the correct position.	Properly position the label mark sensor. For help, see "Adjusting the Label Mark Sensor" in Chapter 5.

**Communication Problems and Preventing Data Loss**

If your printer is not receiving downloaded data, try the solutions in the accompanying table.

Symptom	Possible Causes	Solution
Printer does not communicate with the host.	Serial port is incorrectly configured.	Make sure the printer's serial port settings match those of the host. Print a software test configuration label as described in Chapter 1 to check the serial port settings.
	Damaged or incorrect I/O cable.	Check the connections at both ends or replace the cable. See Appendix C for cable information.

Several problems can cause data loss or communication problems on the printer. Data loss can result in printing errors or missing field data.

Your printer is a serial ASCII device. It communicates with the host through an ASCII serial communication I/O port. Hardware handshaking involves the use of a hardware wire. Software handshaking involves a two-way datalink between the devices. The two devices communicate with each other without losing data through the use of handshaking. The printer sends both forms of handshaking simultaneously when the printer's input buffer is full. Any loss of data can cause printing errors.

Hardware handshaking uses pin 11 or pin 20 of the RS-232 interface to control data flow. When the printer is using Intermec Standard protocol, it holds pins 11 and 20 high when the printer is ready to receive data. The printer holds the pins low when the printer is in one of the following conditions:

- Buffer full
- Ribbon fault
- No label stock
- Label at strip bar

Your printer uses XON/XOFF protocol for software handshaking. When the input buffer is full, the printer transmits an XOFF character. The XOFF character alerts the host to the fact that the printer buffer is full and cannot receive any more data. When the printer is ready to receive more data, it sends the XON character.

The following procedure lists things to check to ensure that your printer and host system are communicating properly.

#### **To check for communication problems**

1. Check the cabling from the printer to the host system.
2. Check the interfacing of the devices that are communicating with the printer.
3. Check the printer for proper electrical operation of the I/O port.
4. Test to see that the host system is not overrunning the printer's input buffers.
5. Check to see that the data string being sent to the printer contains the correct information.

5

## ***Optimizing Printer Performance***





*This chapter explains how to optimize and maintain print quality, use the printer memory more efficiently, and maximize throughput.*

## ***Optimizing and Maintaining Print Quality***

---

Intermec designed and configured your printer to provide the best possible print quality for both direct thermal and thermal transfer media. However, there are many factors that you need to take into account before you can achieve maximum print quality. The following sections contain information on:

- Correcting uneven print quality
- Adjusting the print darkness
- Adjusting the label mark sensor
- Using the printer memory efficiently
- Increasing throughput

## ***Correcting Uneven Print Quality***

---

You may experience problems in print quality (ribbon wrinkling or light print on one side of your label) if the printhead is not making even contact with the label stock. This condition can happen with any size label stock, but is most common when using narrow label stock. You need a straight-slot screwdriver to turn the bias adjust screw.

To achieve the best print quality, adjust the bias adjust screw each time you use media of a different width.



**Note:** You must properly adjust the bias adjust screw to prevent premature printhead failure and excessive platen wear.

**To adjust the bias adjust screw**

1. Remove the media cover and locate the bias adjust screw.

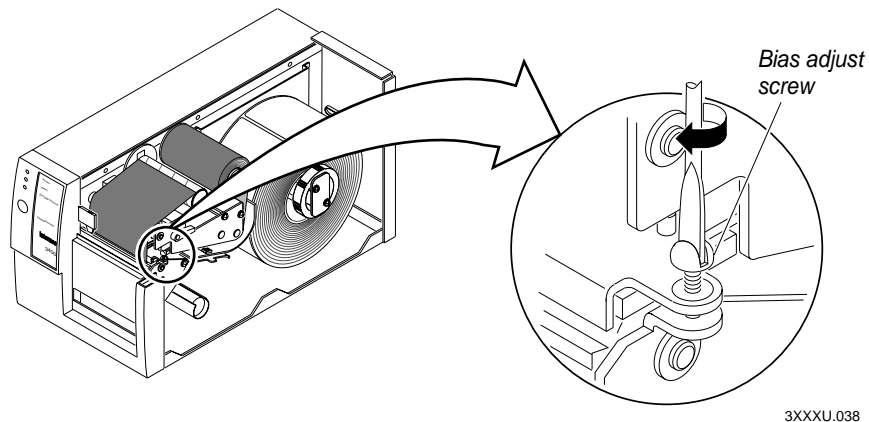

2. To compensate for uneven print quality, turn the bias adjust screw as shown. Adjusting the bias adjust screw causes the printhead to rest evenly on the drive roller and results in even print quality.

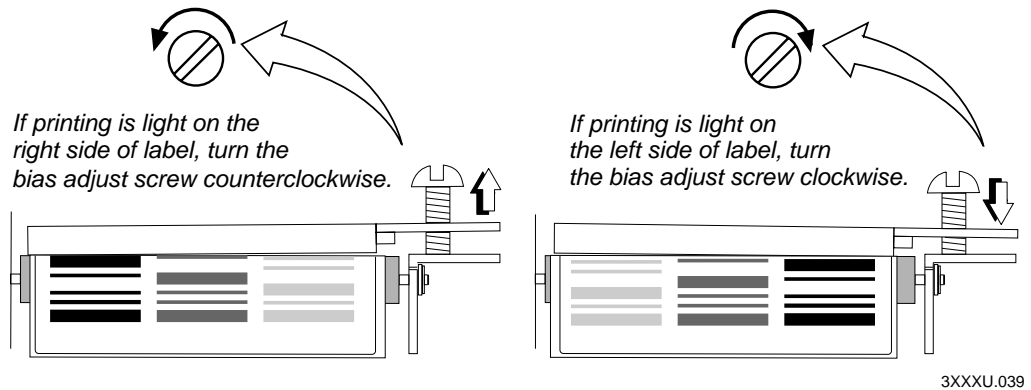

3. Replace the media cover.

## Adjusting the Print Darkness

Use the darkness adjust control in combination with the PrintSet software configuration tool to fine-tune the darkness of print on your labels. The fine adjustments compensate for variations in the media (“lot to lot”), the printhead, or the printer. Set the darkness adjust control **after** you enter the media sensitivity number.

### To adjust the print darkness

1. Locate the darkness adjust control on the back of the printer.
2. Use a small straight-slot screwdriver to adjust the print darkness.
  - To increase the print darkness, turn the control clockwise.
  - To decrease the print darkness, turn the control counterclockwise.

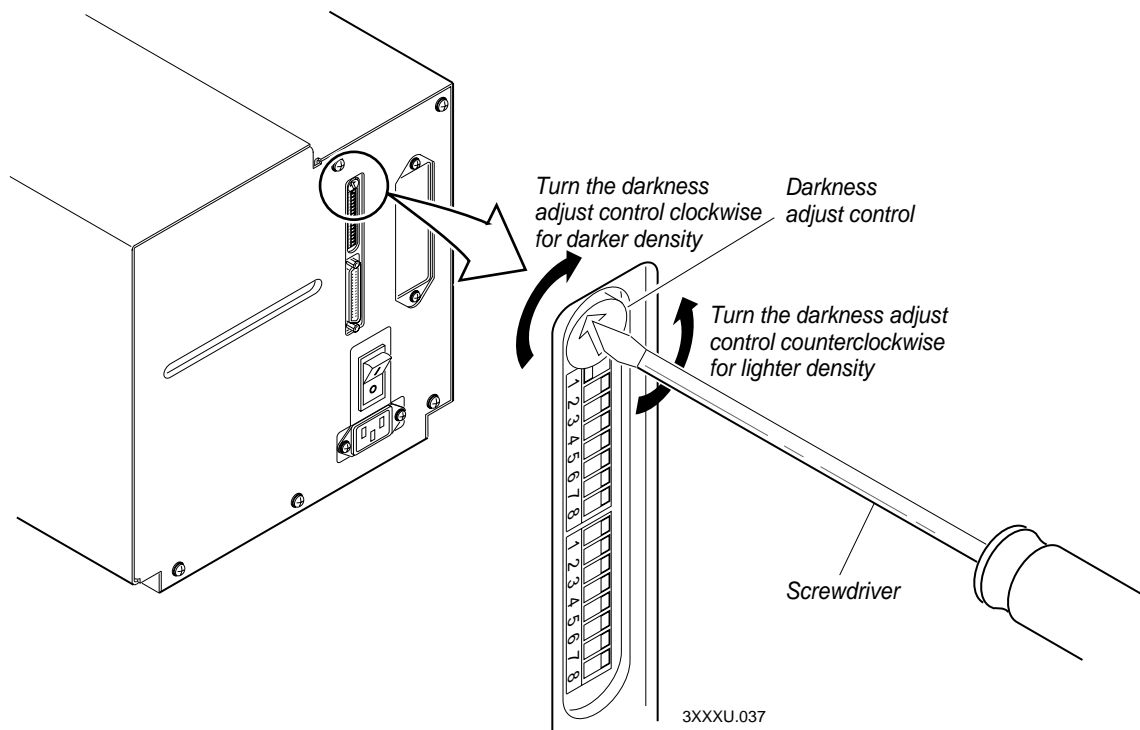

## ***Adjusting the Label Mark Sensor***

---

The label mark sensor detects the mark on the back of continuous media stock. The printer uses the output to determine the start of print. The label mark sensor is behind the platen roller and near the inboard edge of the printer.

### **To adjust the label mark sensor**

1. Remove the media cover and locate the label mark sensor.
2. Use your index finger to slide the label mark sensor to the correct position for your media. You can position the label mark sensor anywhere from the inboard edge of the printer to the center of the paper path.
3. Enable mark printing with PrintSet, your third-party software, or IPL commands. For help, see PrintSet online help, your third-party documentation, or the *IPL Programming Reference Manual*.
4. Print a few labels or press Feed/Pause two times to make sure that the label mark sensor is detecting the black mark on the media.
5. Replace the media cover.

Adjusting the Label Mark Sensor

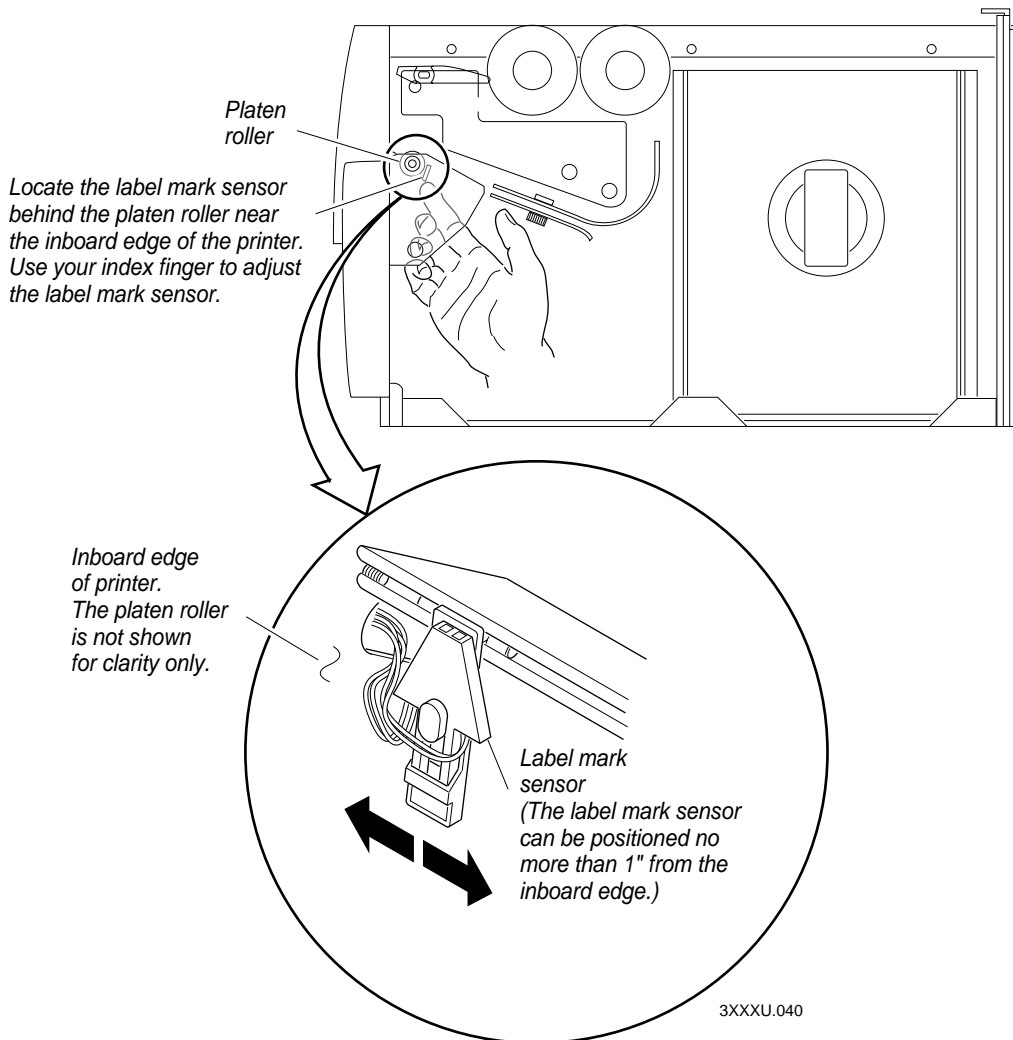

## ***Using the Printer Memory Efficiently***

---

To receive the best performance from your printer, you must understand how to use the printer memory. The following sections can help you determine the most efficient way to use your printer memory.

### ***How Is the Printer Storage Memory Used?***

There is enough storage memory in the printer to store several different label formats and still retain enough memory to store downloaded fonts, graphics, and data. Be careful of how you use your printer memory.

The printer uses flash memory for storing tables, pages, formats, fonts, and user-defined characters (UDCs). The 3400e printer has 128K of flash memory available for storage. If you require additional storage memory, you can purchase flash SIMM for the printer.

The printer supports these parameters independent of the amount of memory installed or allocated by the printer:

- Maximum number of formats: 99  
(You can edit formats 1 to 99. You cannot edit default format 0.)
- Fields per format: 200
- Maximum data buffer size for a field: 3550
- Maximum number of UDCs: 100
- Maximum number of user-defined fonts: 16

### ***Making the Most of Your Memory***

There are limits to the number of formats, fonts, graphics, or pages that you can store in the printer. You can define up to 16 fonts, but there may not be enough room depending on the amount of memory being used for other purposes. The more formats, graphics, and fonts you store, the less memory is available.

When you run into a memory usage problem, use PrintSet to see how much memory remains available. You must upload the memory information from the printer first. Refer to the PrintSet online help for more information.

If you find that it is necessary to increase your available memory, you can do one of the following:

- Increase the amount of available memory by using the Memory Reset portion of the Test and Service menu. See “Resetting the Memory on Your Printer” in Chapter 6 for more information.
- Delete any unneeded user-defined fonts, graphics, pages, or formats. For help, see the PrintSet software or the *IPL Programming Reference Manual*.
- Purchase additional memory. Please contact your Intermec representative for information on purchasing additional memory for the printer.

---

## ***Increasing Throughput***

To print labels as quickly as possible, you must adjust the print speed in conjunction with the number of image bands [one image band equals 2.54 centimeters (1 inch) of label]. The print speed and image band settings determine the rate at which the printer processes the images of your labels. This rate in turn affects the throughput of the entire printing process.

The printer begins imaging the label as soon as it receives the command to select a format. Since the printer starts imaging the label so early, the chance that the imaging process will be unable to keep up with the print speed decreases and throughput improves. However, if the number of image bands is too low, the imaging process is unable to keep up with the print speed. In this case, the printer stops printing and starts again at the lowest print speed with the maximum number of image bands. If the image band command is set too high, the printer spends more time than necessary imaging and slows down label production.

### ***What Is an Image Band?***

Image bands are a section of memory where a picture of a label format is drawn. This drawing process is known as imaging. Once the picture is imaged, the printer loads the picture from the image bands to the printhead for printing. Each image band is equal to 2.54 centimeters (1 inch) of length of the label format. The number of image bands you use may be less than the length of the label you are printing. The number of image bands (in inches) does not have to equal the length of the label since the printer recycles the image bands. Once the contents of an image band have been printed, it may be reused to image the next section of the label.

Keep in mind that the more complex the label, the longer it will take to image each section, thus requiring a slower print speed. To use a higher print speed, use more image bands to allow more of the imaging process to complete before printing begins.

### ***How the Image Bands Command Works***

The image bands command controls the amount of memory allotted to the imaging process. When you increase the image band adjustment to a higher number, you add more buffers to the imaging memory. By doing this, more of the label format is imaged before printing begins.

The minimum number of required image bands is dependent upon the print speed and the complexity of the label. Labels that contain numerous fields with different rotations, graphics, or combinations of these formatting options may require a higher number of image bands.

To set the number of image bands, use PrintSet or the IPL command. For help, see the PrintSet online help or the *IPL Programming Reference Manual*.

### ***Optimizing Print Speed and Image Band Setting***

The maximum number of image bands available for use is 20 bands. The minimum number of image bands available is 2.

#### **To optimize the number of image bands for your print speed**

1. Set the image band setting at the lowest number (2).
2. Print a label at the desired speed.

If the label prints, the image band setting is optimal. You do not need to perform any more adjustments.

If the number of image bands is too low, the printer aborts the label before printing is completed and attempts to reprint the label at the slowest speed (2 ips) with the highest number of image bands (20). You need to continue with Step 3.

3. Return to the original print speed and increase the original number of image bands one at a time.

Continue to increase the number of image bands until the printer prints a label correctly.

If the printer still aborts and reprints at the highest image band setting, you may be trying to optimize at a print speed that is too high for your label format. Try optimizing the number of image bands at a lower print speed or add an expansion DRAM SIMM.

To print very complex labels at high speeds, you must allocate enough image bands to completely image the label before printing. Allocate one band for each inch of label length. By doing this, you can print at any speed. However, there may be a considerable delay between labels.





## ***Using Test and Service Mode***



*This chapter explains the different procedures you can perform while the printer is in Test and Service mode. Use Test and Service mode on the printer to print test labels, perform special procedures, and change select configuration commands.*

## **Using Test and Service Mode Procedures**

---

For all Test and Service mode tests, pressing the Feed/Pause button pauses the current test. Holding the Feed/Pause button aborts the current test and starts a new test.

### **To enter Test and Service mode**

1. Record your current DIP switch settings for later reference.
2. Set all of the DIP switches to the off position.  
Set all of the DIP switches to the communications settings of your host computer.
3. Turn the On/Off switch to the off position.
4. Press and hold the Feed/Pause button while turning the power on.

The printer prints out a hardware configuration label and then enters Data Line Print mode.

5. Set the DIP switches to the test or service function you wish to perform. See the following table for a list of the DIP switch settings.
6. Hold the Feed/Pause button down. The test begins immediately.
7. If you wish to perform another function, change the DIP switch settings and press the Feed/Pause button.

The function the printer is currently executing terminates, and the printer performs the new function.

The printer remains in Test and Service mode until you turn the power off and reset the DIP switches. The printer executes all functions as soon as you select them.

### **To exit Test and Service mode**

1. Turn the printer power off.
2. Reset the DIP switches to their original settings.
3. Turn the printer power back on.

Use the information in the following table to set the DIP switches for the appropriate Test and Service mode function you want to perform.

**Test and Service DIP Switch Settings**

Default settings are noted with an \*

	Top Bank								Bottom Bank							
	OFF								ON							
TESTS	1	2	3	4	5	6	7	8	1	2	3	4	5	6	7	8
<b>Test Prints</b>	O O O															
Configurations																
Hardware*									O O O							
Software									1 O							
<b>Test Labels</b>	1 O O															
Print Quality									O O							
Pitch									1 O							
<b>Page</b>	O 1 O O O															
Single Page									N N N N N							
All Pages									1 1 1 1 1							
<b>Format</b>	1 1 O O O															
Single Format									N N N N N							
All Formats									1 1 1 1 1							
<b>UDC</b>	O O 1 O O															
Single UDC									N N N N N N N							
All UDCs									1 1 1 1 1 1 1							
<b>Font</b>	1 O 1 O O															
Single Font									N N N N N							
All Fonts									1 1 1 1 1							
<b>Data Line Print</b>	*1 O O O O O O O															
<b>Selective Transfer</b>	1 1 O															
Receiver									O O O							
Send Pages	1 O O S															
Single Page									1 S							
All Pages									1 1 1 1 1 1 1 1							
Send Format	O 1 O S															
Single Format									1 S							
All Formats									1 1 1 1 1 1 1 1							
Send UDC	1 1 O S															
Single UDC									1 S							
All UDCs									1 1 1 1 1 1							
Send Font	O O 1 S															
Single Font									1 S							
All Fonts									1 1 1 1 1 1							
Send Configuration	1 O 1															
Send Tables	O 1 1															
Send All	1 1 1															
<b>Memory Reset</b>	O O 1															
Page/Format									O O O							
UDC/Font									1 O O							
Configuration									O 1 O							
Tables									1 1 O							
All									1 1 1							

Q: OFF = Batch of 1. ON = Batch of 100.  
 N: Page/Format/UDC/Font number. Least significant bit first.  
 S: Source Page/Format/UDC/Font number. Least significant bit first.  
 D: Destination Page/Format/UDC/Font number. Least significant bit first.

3XXXU.041

---

## **Printing Test Labels**

The printer can print a variety of test print labels that provide you with information about the printer configuration and the quality of the printing.

### **To print a test label**

1. Turn the On/Off switch to the off position.
2. Press and hold the Feed/Pause button while turning on the printer.  
The printer prints a hardware configuration label and then enters Data Line Print mode.
3. Set the DIP switches to print the test label of your choice: software, print quality, or pitch. Refer to the Test and Service DIP Switch Settings table for the correct settings.
4. Hold the Feed/Pause button down until the printer starts printing.  
The printer begins printing out the test label immediately.
5. Exit Test and Service mode by turning the printer off and returning all DIP switches to their original settings.

---

## **Using Data Line Print**

Use Data Line Print mode to troubleshoot communication between the printer and the host and to test the operation of the printer. When the printer is in Data Line Print mode, it prints out all downloaded data with the hexadecimal equivalent directly underneath it. Hold the Feed/Pause button down to momentarily suspend the test. Press the Feed/Pause button longer to transmit the firmware program and version number to the host.

### **To enter Data Line Print mode**

1. Turn the On/Off switch to the off position.
2. Press down and hold the Feed/Pause button while turning on the printer.

The hardware configuration test label prints out. You are now in Data Line Print mode.

---

## ***Resetting the Memory on Your Printer***

Use memory reset if you want to return your printer to its default configuration or if you need to increase the amount of memory available in your printer. You can also use memory reset to clear pages and formats, user-defined characters and fonts, configurations, tables, or all of these parameters.

### **To use memory reset**

1. Turn the printer off.
2. Press and hold the Feed/Pause button while turning on the printer. The printer prints a hardware configuration test label.
3. Set the DIP switches to reset a portion or all of the memory by using the Test and Service DIP Switch Settings table on page 6-4.
4. Hold the Feed/Pause button down for 1 second. The printer resets a portion or all of its memory.

---

## ***Setting Configuration Commands in Test and Service Mode***

Test and Service mode also provides you with an alternative to using PrintSet or sending configuration commands down from the host. You can change these configuration commands by setting the Test and Service mode DIP switches:

- Label rest point
- 86XX emulation
- X forms adjust
- Y forms adjust

The following table provides you with the Test and Service mode DIP switch settings for changing the configuration commands.

Configuration DIP Switch Settings

	Top Bank								Bottom Bank							
	OFF								ON							
	1	2	3	4	5	6	7	8	1	2	3	4	5	6	7	8
Label Rest Point	0	1	1													
Adjust Forward					0				N	N	N	N	N			
Adjust Backward					1				N	N	N	N	N			
86XX Emulation	1	0	1													
Advance Mode					0	0										
10 Mil					1	0										
15 Mil					1	1										
X Forms Adjust	1	1	1	1												
Adjust Forward						0			N	N	N	N	N			
Adjust Backward						1			N	N	N	N	N			
Y Forms Adjust	1	1	1	0					N	N	N	N	N			

N: Number. Least significant bit first.

3XXXU.046

**Setting the Number of Dot Increments**

You can move the label rest point and X forms adjust configuration commands forward or backward by setting the printer DIP switches. Use the top bank of DIP switches to determine whether the movement is forward or backward. Use the bottom bank of DIP switches to set the number of dot increments for label rest point, X forms adjust, and Y forms adjust. The printer moves in 5 mil increments or 0.005 inch per dot.



**Note:** The next table only shows the settings for the bottom bank of switches, see the Configuration DIP Switch Settings table for the top bank DIP switch settings.

Dot Increments DIP Switch Settings

Bottom Bank

0 = OFF  
1 = ON

OFF

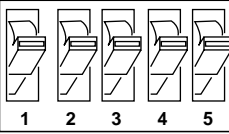

ON

# of dot increments	1	2	3	4	5
1	1	0	0	0	0
2	0	1	0	0	0
3	1	1	0	0	0
4	0	0	1	0	0
5	1	0	1	0	0
6	0	1	1	0	0
7	1	1	1	0	0
8	0	0	0	1	0
9	1	0	0	1	0
10	0	1	0	1	0
11	1	1	0	1	0
12	0	0	1	1	0
13	1	0	1	1	0
14	0	1	1	1	0
15	1	1	1	1	0
16	0	0	0	0	1
17	1	0	0	0	1
18	0	1	0	0	1
19	1	1	0	0	1
20	0	0	1	0	1
21	1	0	1	0	1
22	0	1	1	0	1
23	1	1	1	0	1
24	0	0	0	1	1
25	1	0	0	1	1
26	0	1	0	1	1
27	1	1	0	1	1
28	0	0	1	1	1
29	1	0	1	1	1
30	0	1	1	1	1

3XXXU.047



**To set the number of dot increments.**

1. In the top bank, turn the appropriate switches on or off for forward or backward movement. See the Configuration DIP Switch Settings table on page 6-7 for the appropriate DIP switch settings.
2. Go to the Dot Increments DIP Switch Settings table on page 6-8 and scan down the # of Dot Increments column until you reach the number of dot increments you want to adjust the command forward or backward.
3. In the bottom bank turn on the switches that have a 1 in their column. Turn off all other switches.
4. Press the Feed/Pause button and the printer prints the software configuration label and stops at the new location.

For example, you print a label and discover that it does not extend far enough from the tear bar. You need to move the label rest point forward 10 dot increments (0.05 inch) so that the printer feeds more label out when it is done printing. Find 10 in the # of Dot Increments column. It shows a 1 in the columns of DIP switches 2 and 4, and a 0 in the columns of 1, 3, and 5. The 1 tells you to turn the switch on. The 0 tells you to turn the switch off. Turn on switches 2 and 4. Turn off all other switches.

---

***Adjusting the Label Rest Point***

The label rest point configuration command adjusts the point at which the printer presents each label for removal. Use this command in conjunction with self-strip applications. The label rest point adjust range is from -30 dot increments (farthest back) to +30 dot increments (farthest forward).

Use a negative number if you want the printer to retract the label a number of dot increments after it prints the label. Use a positive number if you want the printer to feed the label a number of dot increments after it prints the label.

There are three ways to adjust the label rest point:

- You can use the Test and Service DIP switch bank. Follow the procedure below to use the DIP switch settings to adjust the label rest point.
- You can set it by using the PrintSet application software. See the Paper Handling portion of PrintSet for more information.
- You can use the IPL command. See the *IPL Programming Reference Manual* for more information.

### To adjust the label rest point

1. Turn the On/Off switch to the off position.
2. Press and hold the Feed/Pause button while turning on the printer.

The printer prints the hardware configuration test label and then enters Data Line Print mode.

3. In the top bank of the Test and Service DIP switches, turn off switch 1 and turn on switches 2 and 3.

To adjust the label rest point forward (feed more label), turn off DIP switch 4.

To adjust the label rest point backward (retract label), turn on DIP switch 4.

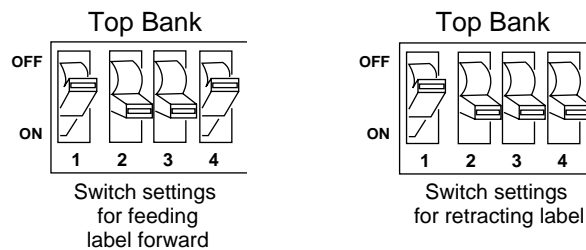

3XXXU.48

4. In the bottom bank of the Test and Service DIP switches, turn on or off the appropriate DIP switches. See the Dot Increments DIP Switch Settings table on page 6-8.
5. Press the Feed/Pause button.  
The printer prints the software configuration label and stops at the new location.
6. Verify that the label rest point number on the software configuration label matches the number you set in Step 4.
7. Try printing again to see if you need to readjust the DIP switches in the bottom bank.
8. If you need to readjust the DIP switches in the Bottom Bank, repeat Steps 4 through 7. If not, exit Test and Service mode by turning off the printer and returning all DIP switches to their original settings.

## Setting Emulation Mode

If you are replacing an Intermec 8636 or 8646 printer with a 3400e printer, you can keep your existing network, hardware, software, and label formats by using Emulation mode. The labels produced on your new printer will look like the ones that your old 86XX printer printed.

There are three ways to set the printer to Emulation mode:

- Use the DIP switches in the Test and Service DIP switch bank. For help, see the following procedure.
- Use PrintSet to select either 100 dpi (10 mil) or 66 dpi (15 mil) mode. For help, see the PrintSet online help.
- Use the IPL command set to select Emulation mode. For help, see the *IPL Programming Reference Manual*.

### To set the printer to Emulation mode using DIP switches

1. Upload label formats, fonts, and graphics from the 8636 or 8646 printer to the host computer.
2. Turn the On/Off switch to the off position.
3. Disconnect the 86XX printer and install your printer. See Chapter 1 for information on installing your printer.
4. Press and hold the Feed/Pause button while turning on the printer. The printer prints the hardware configuration label.
5. In the top bank of the Test and Service DIP switches, turn on switches 1 and 3 and turn off switch 2.
6. Use the table below to help you choose the appropriate DIP switch settings:

Setting	Description
Emulation 10 mil	The printer emulates an 8636 or 8646 printer printing multiples of 10 mil (0.01 inch) drag and 10 mil (0.01 inch) picket bar codes.
Emulation 15 mil	The printer emulates an 8636 or 8646 printer printing multiples of 10 mil (0.01 inch) drag and 15 mil (0.015 inch) picket bar codes.
Advanced 5 mil (default)	The printer uses the 3400 command set and prints in multiples of 5 mil (0.005 inch) drag and 5 mil (0.005 inch) picket bar codes.

7. To enable 10 mil emulation, turn on DIP switch 4 and turn off DIP switch 5.  
To enable 15 mil emulation, turn on DIP switches 4 and 5.  
To enable 5 mil Advanced mode, turn off DIP switches 4 and 5.

8. Press the Feed/Pause button.  
The printer prints out the software configuration label. Verify that the label states the correct mode.
9. Turn the printer off and then on.
10. Download the 86XX formats, fonts, and graphics from the host to the printer.

---

## Using Forms Adjust

If your label prints too close to one edge, you can reposition it by using the X Forms Adjust and Y Forms Adjust features. The X forms adjust controls the position of the printing area along the length of the label. The Y forms adjust controls the position of the printing area along the width of the label.

The following figure shows the default X and Y origins. You can control the default X origin (top of form) with the PrintSet software or with the Test and Service DIP switches. You can control the default Y origin with the DIP switches only.

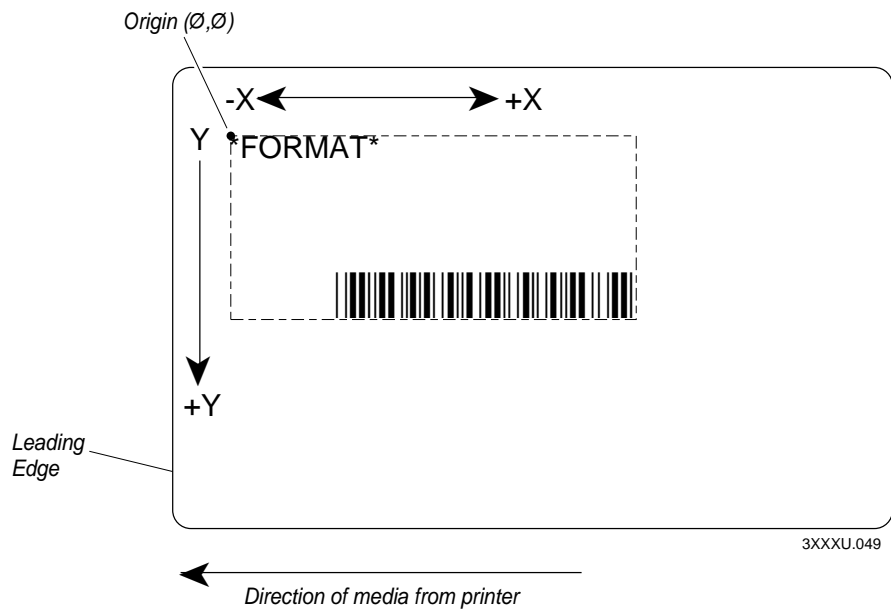

The default X origin is .25 centimeters (0.10 inch) (20 dot increments) from the edge of the label. You can move the X origin forward or back 30 dot increments. The default Y origin is .13 centimeters (0.05 inch) (10 dot increments) from the leading edge of the label. Each dot increment is 5 mil (0.005 inch).

### ***X Forms Adjust***

When you move the X origin forward, the printer moves the top of form away from the edge before printing the label information. When you move the X origin backward, the printer moves the top of form closer to the edge before printing the label information.

#### **To set the X forms adjust**

1. Turn the On/Off switch to the off position.
2. Press and hold the Feed/Pause button while turning on the printer.

The printer prints out the hardware configuration label and then enters Data Line Print mode.

3. In the top bank of the Test and Service DIP switches, turn on switches 1, 2, 3, and 4.

To move the X origin forward, turn off switch 5.

To move the X origin backward, turn on switch 5.

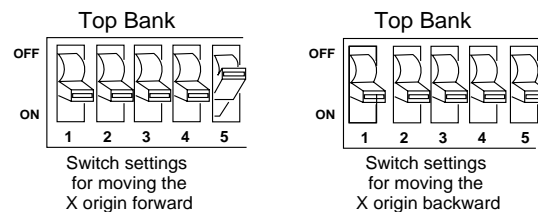

3XXXU.050

4. In the bottom bank of the Test and Service DIP switches, turn on or off the appropriate DIP switches. See the Dot Increments DIP Switch Settings table on page 6-8 to see how to set the X forms adjust forward or backward a given number of increments.

5. Press the Feed/Pause button.

The printer prints out the software configuration label using the new X forms adjust setting.

6. Verify the X forms adjust number on the software configuration label matches the number you set in Step 4.

### ***Y Forms Adjust***

Use the Y Forms Adjust feature to control the position of the image in the direction parallel to the printhead. See the Dot Increments DIP Switch Settings table on page 6-8 for information on how to move the image forward a number of dot increments. If your label is too close to one edge of the printhead, you can adjust it using this feature.

#### **To set the Y forms adjust**

1. Turn the On/Off switch to the off position.

2. Press and hold the Feed/Pause button while turning on the printer.

The printer prints out the hardware configuration label and then enters Data Line Print mode.

3. In the top bank of the Test and Service DIP switches, turn on switches 1, 2, and 3.

4. In the bottom bank of the Test and Service DIP switches, turn on or off the appropriate DIP switches. See the Dot Increments DIP Switch Settings table on page 6-8 to see how to set the X forms adjust forward or backward a given number of increments.

5. Press the Feed/Pause button. The printer prints out the software configuration label using the new Y forms adjust setting.

6. Verify the Y forms adjust number on the software configuration label matches the number you set in Step 4.

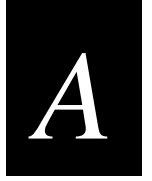

# ***Specifications***





## Printer Specifications

---

This section describes the specifications of the 3400e printer.

### **Electrical Requirements**

Input Voltage 100, 120, or 230 VAC  $\pm$  10%  
Frequency 47-63 Hz

### **Printing Method**

The 3400e printer is capable of direct thermal (DT) printing or thermal transfer (TTR) printing using thermal transfer ribbon.

### **Environment**

Operating 10°C to 40°C (50°F to 104°F)  
Humidity 10% to 90% noncondensing

### **Self-Strip (optional)**

The self-strip rewinder hub can take up the backing of an entire 15,240-centimeter (6,000-inch) roll of media.

Peel Release 10-50 grams



**Note:** Self-strip printing is an option that you order with your printer.

### **Communications**

Asynchronous RS-232C, RS-422, RS-485 interfaces  
Serial ASCII code  
Hardware (Ready/Busy) Flow Control  
XON/XOFF Protocol  
Intermec Standard Block Protocol  
Polling Mode D Protocol  
Multi-Drop Protocol  
Baud Rates: 1,200, 2,400, 4,800, 9,600, 19,200, 38,400, 57,000, 115,200

---

## **Specifications**

### **Dimensions (no options installed)**

Height 27.9 cm (11 inches)  
Width 26.7 cm (10.5 inches)  
Length 43.2 cm (17 inches)  
Weight 15.8 kg (35 pounds)

**Printhead (200 dpi)**

Printed dot size	0.127 mm (0.00492 inch square)
Width	104 mm (4.1 inches square)
Resolution	8 dots per mm (203 dots per inch)
Number of elements	832 per printhead
“X” dimensions	10 mil to 50 mil (0.25 mm to 1.27 mm); 5 mil (0.13 mm) in drag mode only (specified media only)

**Printhead (400 dpi)**

Printed dot size	0.065 mm (0.0025 inch square)
Width	112 mm (4.4 inches maximum)
Resolution	16 dots per mm (406 dots per inch)
Number of elements	1,792 per printhead
“X” dimensions	5 mil to 50 mil (0.127 mm to 1.27 mm); 2.5 mil (0.06 mm) in drag mode only (specified media only)

**Ribbon**

Roll	152 m (6,000 linear inches)
Widths	51 mm (2.0 inches) 76 mm (3.0 inches) 104 mm (4.1 inches)
Diameter	57 mm (2.25 inches maximum)

**Printing Speed**

Maximum	8 inches (152.4 mm) per second
Minimum	2 inches (50.8 mm) per second

You can change the print speed in 1 ips increments only: 2, 3, 4, 5, 6, 7, or 8.

**Fonts and Graphics**

There are 21 resident bitmap fonts (including OCR A and B) and three outline fonts available on the e series printers. You can use font ID 3 through 6 and 8 through 19 to download user-defined fonts.

Maximum UDF	102 mm square (4 inches square)
Maximum UDC	102 mm square (4 inches square)

**Character Sets**

US ASCII	Norwegian/Danish	French
UK ASCII	Swedish/Finnish	Swiss
German	Italian	Spanish



**Media**

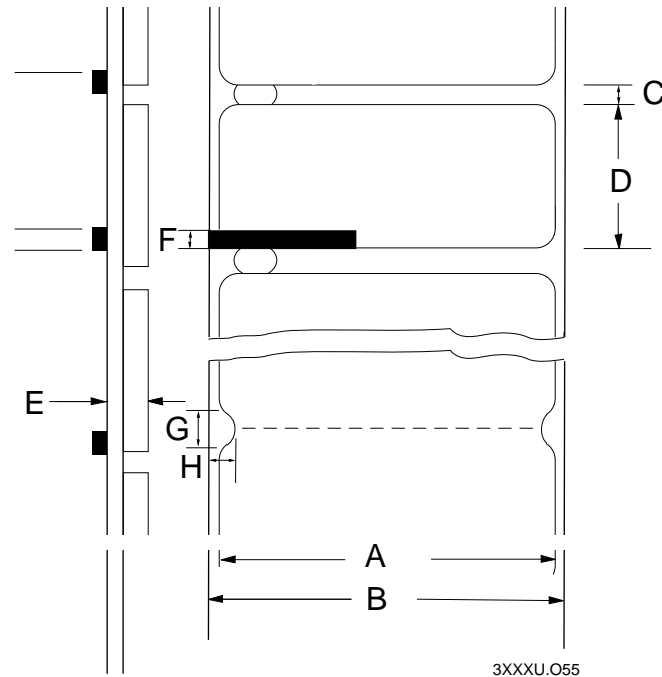

3XXXU.055

Number	Description	Minimum	Maximum
A	Label width	16.5 mm (0.65 inch)	111.8 mm (4.4 inches)
B	Backing width (or tag width)	19.1 mm (0.75 inch)	114.3 mm (4.5 inches)
C	Gap between labels	2.54 mm (0.10 inch)	25.4 mm (1.0 inch)
D	Label length - self-strip media	25.4 mm (1.0 inch)	609.6 mm (24 inch)
	Label length - butt cut media	12.7 mm (0.5 inch)	609.6 mm (24 inch)
E	Media thickness (including backing)	0.15 mm (0.0059 inch)	0.30 mm (0.012 inch)
F	Reflective sensor mark length	2.54 mm (0.10 inch)	12.7 mm (0.5 inch)
G	Notch diameter	3.18 mm (.125 inch)	N/A
H	Notch height	6.4 mm (0.25 inch)	N/A
	Roll diameter	N/A	213 mm (8.38 inches)

## **Printer Options**

---

This page contains a list of the options you can use with the printer along with a brief description. Consult your Intermec representative to order any option.

---

### **Communication Interface**

#### **EasyLAN 10i Interface**

This option lets you connect your printer to a 10bBaseT Ethernet network. Various network printing protocols are available. For more information, see your EasyLAN 10i documentation.

#### **Twinax Interface**

This option lets you connect your printer to an IBM twinaxial cable system with a twinax interface so your printer emulates an IBM 5256 Model 1 printer and can operate with an IBM System/34, System/36, System/38, or AS/400 host computer.

#### **Coax Interface**

The coax interface adapter allows the printer to emulate an IBM 3287 printer by connecting the printer to IBM 3270 Type A coaxial cable computer systems operating in the VTAM (CICS/IMS/TSO) or 8100 (DPPX) environments. With the coaxial adapter you can connect the printer to an IBM 3174/76/99 system controller/multiplexer.

---

### **Finishers**

#### **Cutter**

Use the cutter option to cut continuous media into individual labels ready for use. This 3400 option works best for individual random lengths or short batches of different label lengths.

#### **Batch Takeup**

This device automatically spools labels as they are printed. This attachment is limited to small batches with maximum outer diameter (OD) of 12.7 centimeters (5 inches).

#### **Self-Strip Printing**

Use self-strip printing in applications where you want to apply labels to a surface immediately. After printing a label, the printer prints out the label with the backing removed. This option must be ordered when you order your printer.

The following pin descriptions are for the printer's parallel interface connector:

Signal	Pin	Return	Direction	Description
DATASTB	1	19	IN	Negative pulse. Latches DB0-7 on the rising edge. Eight bits in parallel provide data input. High is logical 1 and LOW is logical 0.
DB0	2	20	IN	
DB1	3	21	IN	
DB2	4	22	IN	
DB3	5	23	IN	
DB4	6	24	IN	
DB5	7	25	IN	
DB6	8	26	IN	
DB7	9	27	IN	
ACK	10	28	OUT	Negative pulse. Data has been received.
BUSY	11	29	OUT	If HIGH, printer cannot receive data.
PE	12	30	OUT	If HIGH, out of ribbon or media.
SELECT	13	-	OUT	Pulled to +5V. Printer is on.
CHASSIS GND	17	-	-	Printer's chassis gnd isolated from logic gnd.
INIT	31	16	IN	Clears I/OINT0 latch.
FAULT	32	33	OUT	See printer display.

## **Bar Code Symbologies Supported**

---

The e series printers support these bar code symbologies:

**Codabar** Originally developed in 1972, Codabar is a numeric symbology most commonly used in libraries, blood banks, and air parcel express applications.

**Code 2 of 5** Code 2 of 5 is a straightforward numeric symbology developed in the late 1960s. It has been used for warehouse sorting systems, photofinishing envelope identification, and for tracking sequentially numbered airline tickets. All information is contained in the width of the bars; the spaces do not contain information.

**Code 11** Code 11 was developed in early 1977 to satisfy requirements for a very high density, discrete numeric bar code. The most extensive application of Code 11 has been for labeling telecommunications equipment.

**Code 39** Code 39 is the first alphanumeric symbology ever developed and is the standard non-retail bar code. It is a discrete, self-checking symbology of variable length and is used mostly by the automobile and medical industries.

**Code 93** Introduced in 1983, Code 93 was specially designed to complement Code 39. With the correct reading equipment, the two alphanumeric codes may be interchanged throughout a system without making any changes to software.

**Code 128** Code 128 was introduced in 1981 as a very high density, alphanumeric symbology. It is a variable length, continuous code that employs multiple element widths.

**EAN** The European Article Numbering system (abbreviated as EAN) is a numeric superset of UPC. EAN has both a version that uses 8 digits and a version that uses 13 digits. The version with 13 digits encodes the same number of bars as 12 digit UPC Version A, but the 13th digit is encoded into a parity pattern at the left of the center guard bar.

**Interleaved 2 of 5** Interleaved 2 of 5 is a high density, self-checking, continuous numeric symbology, which has mainly been used in the distribution industry. Interleaved 2 of 5 actually encodes two digits, one in the bars and one in the spaces.

**POSTNET** The Postal Numeric Encoding Technique (POSTNET) uses binary digits, represented as full bars and half bars, to provide a numeric bar code symbology that is easily read and decoded by optical reading systems. POSTNET provides both error detection and correction capabilities.

### **HIBC 128**

See the *IPL Programming Reference Manual* for a complete list.

**UPC** Universal Product Code (UPC) is a subset of EAN. It is a fixed length, numeric, continuous symbology employing four element widths. Two common types of UPC are Version A, which encodes 12 digits, and Version E, which encodes 6 digits. UPC has been used in the supermarket industry since 1973. UPC supplemental code is intended for only periodical issue numbers.

---

## **2D Symbologies**

2D symbologies provide a more efficient way of encoding data than standard bar code symbologies. 2D symbologies use two dimensions to hold data instead of one, allowing much more information to be stored in a smaller amount of space. Your printer provides the capability for printing both stacked and matrix 2D symbologies.

### **2D Stacked Symbologies**

2D stacked symbologies consist of short linear segments stacked on top of each other. In addition to being able to condense a large amount of information into the stacked format, PDF417 provides an extensive error detection and correction option. Up to 510 characters can be recovered if they are lost due to an error in scanning or if the label is damaged. 2D stacked symbologies can be scanned with a laser scanner or imaging device that features 2D code scanning capability.

**Code 16K** Introduced in 1988, Code 16K is an alphanumeric symbology similar to Code 49 in that it employs multiple rows (from 2 to 16). Each row is fixed length and uses a mirror image of the Code 128 coding patterns.

**Code 49** Code 49 is an alphanumeric symbology developed in 1987 as a means of labeling very small objects. A Code 49 bar code contains from two to eight adjacent rows, each separated by a one-module separator bar.

**PDF417** PDF417 is a stacked 2D symbology that provides the ability to scan across rows of code. Each row consists of start/stop characters, row identifiers, and symbol characters (called “codewords”). Each codeword consists of four bars and four spaces and contain the actual data. In addition to being able to condense a large amount of information into the stacked format, PDF417 provides an extensive error detection and correction option. Up to 510 characters can be recovered if they are lost due to an error in scanning or if the label is damaged. PDF417 codes can be scanned with a laser scanner or imaging device that features 2D code scanning capability.

### **2D Matrix Symbologies**

2D matrix symbologies, such as Maxicode, use both the horizontal and vertical axes to encode data even more efficiently than stacked symbologies. 2D matrix codes are created as a matrix of square elements, with each element being either white or black to encode data in a binary code. Extensive error detection and correction codes are appended to 2D matrix symbologies, often automatically.

2D matrix symbologies generally cannot be read with a laser scanner. Instead, they are read by a digital imager that captures the entire symbol at once instead of scanning each component individually. Since the components of 2D matrix symbologies are decoded after the image is captured, they permit very fast data collection.

**Data Matrix** Data Matrix is a 2D matrix symbology which is made up of square modules arranged within a perimeter finder pattern. The finder pattern is a perimeter to the data region and is one module wide. Two adjacent sides are solid dark lines. These lines are used to define physical size, orientation, and symbol distortion.

**Maxicode** Maxicode is a fixed-size symbology that is made up of offset rows of hexagonal elements arranged around a bullseye finder pattern. Each hexagon represents one bit of information and is either black or white depending on the state of the encoded data bit. United Parcel Service (UPS) Research and Development developed Maxicode for the specific purpose of encoding information about a parcel.

This symbology only encodes very specific data that is divided into the following fields: a 5-digit zip code, a 4-digit zip code extension, a 3-digit country code, a 3-digit class of service, and a string of uppercase letters, numbers, or limited punctuation marks.

**QR Code** QR (Quick Response) Code is a matrix 2D symbology that encodes data into patterns consisting of black and white dots or modules. A three position detection pattern enables omni-directional reading and ultra high-speed reading. QR Code can handle a wide range of data, including numerical, alphabetical, Kanji, Hiragana, Katakana, graphics, and control codes. A built-in error correction function enables the QR Code to repair errors in the code.



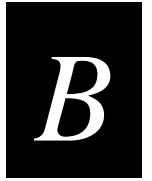

## ***Character Sets***



*This chapter contains tables for the character sets that the 3400e printer supports. To select a character set, use PrintSet, your third-party software application, or the IPL command set.*

## **International Character Sets**

The following tables show which hex codes to download for international characters not available in the U.S. character set. To use the tables, find the hex code for the U.S. character that corresponds with the character in your language.

### **Advanced Character Table**

If you are running your printer in Advanced mode (you are not using 86XX Emulation), use this table to find the right hex codes for the international character sets.

	23	24	40	5E	5C	5D	5E	60	7B	7C	7D	7E
U.S. ASCII	#	\$	@	[	\	]	^	`	{		}	~
U.K. ASCII	£	\$	@	[	\	]	^	`	{		}	—
Germany	#	\$	§	Ä	Ö	Ü	^	`	ä	ö	ü	ß
France	£	\$	à	°	ç	§	^	`	é	ù	è	¨
Norway/Denmark	#	\$	@	Æ	Ø	Å	^	`	æ	ø	å	—
Sweden/Finland	#	¤	É	Ä	Ö	Å	Ü	é	ä	ö	å	ü
Spain	£	\$	§	ı	Ñ	ı	^	`	°	ñ	ç	~
Switzerland	#	\$	à	°	ç	é	^	ù	ä	ö	ü	è
Italy	£	\$	§	°	ç	é	^	ù	à	ò	è	ì

## Emulation Mode Character Table

This table shows the hex codes for the character sets that print if your printer is running under Emulation mode.

	23	24	40	5B	5C	5D	5E	60	7B	7C	7D	7E
U.S. ASCII	#	\$	@	[	\	]	^	`	{		}	~
U.K. ASCII	£	\$	@	[	\	]	^	`	{		}	~
Germany	#	\$	§	Ä	Ö	Ü	^	`	ä	ö	ü	ß
France	£	\$	à	°	ç	§	^	`	é	ù	è	¨
Norway/Denmark	#	\$	@	Æ	Ø	Å	^	`	æ	ø	å	~
Sweden/Finland	#	¤	É	Ä	Ö	Å	Ü	é	ä	ö	å	ü
Spain	Pt	\$	@	¡	Ñ	¿	^	`	¨	ñ	ç	~
Switzerland	#	\$	à	°	ç	é	^	ù	ä	ö	ü	è
Italy	#	\$	§	°	ç	é	^	ù	à	ò	è	ì

## IBM Translation Character Table

If you are running your printer with IBM Translation enabled, use this table to find the right hex codes for the international character sets.

	21	23	24	40	5B	5C	5D	5E	60	7B	7C	7D	7E
U.S. ASCII		#	\$	@	¢	\	!	¬	`	{		}	~
U.K. ASCII		#	£	@	\$	\	!	¬	`	{		}	—
Germany	!	#	\$	§	Ä	Ö	Ü	^	`	ä	ö	ü	ß
France	!	£	\$	à	°	ç	§	^	`	é	ù	è	¨
Norway/Denmark	!	Æ	Å	Ø	#	\	¤	^	`	æ	ø	å	ü
Sweden/Finland	!	Ä	Å	Ö	§	É	¤	^	é	ä	ö	å	ü
Spain		Ñ	Pt	@	[	\	]	¬	`	{	ñ	}	¨
Switzerland	!	#	\$	à	°	ç	é	^	ù	ä	ö	ü	è
Italy	!	£	\$	§	°	ç	é	^	ù	à	ò	è	ì



## Code Page 850 Character Table

00	☺	☹	♥	♠	♣	♠	●	◻	◯	◉	♂	♀	🎵	🎶	☀	
10	▶	◀	↕	⏹	¶	▬	↕	↑	↓	→	←	↔	▲	▼		
20	!	"	#	\$	%	&	'	(	)	•	+	,	-	.	/	
30	0	1	2	3	4	5	6	7	8	9	:	;	<	=	>	?
40	@	A	B	C	D	E	F	G	H	I	J	K	L	M	N	O
50	P	Q	R	S	T	U	V	W	X	Y	Z	[	\	]	^	-
60	˘	a	b	c	d	e	f	g	h	i	j	k	l	m	n	o
70	p	q	r	s	t	u	v	w	x	y	z	{		}	~	⏏
80	Ç	ü	é	â	ä	à	â	ç	ê	ë	è			Ä	Å	
90	É	æ	Æ	ô	ö	ò	û	ù	ÿ	Ö	Ü	ø	£	Ø	X	f
A0	á	í	ó	ú	ñ	Ñ	ã	õ	¿	®	¬	½	¼	¡	«	»
B0	ı	ı	ı	ı	ı	ı	ı	ı	ı	ı	ı	ı	ı	ı	ı	ı
C0	ı	ı	ı	ı	ı	ı	ı	ı	ı	ı	ı	ı	ı	ı	ı	ı
D0	đ	Đ	Ê	Ë	È	€	Í	Î	Ï	Ĵ	Ŕ	▣	▣	ı	ı	▣
E0	Ó	ß	Ô	Ò	Õ	μ	þ	p	Ú	Û	Ü	Ý	Ý	-	'	
F0	-	±	=	¾	¶	§	÷	•	◦	••	•	1	3	2	■	■
	F1	F2	F3	F4	F5	F6	F7	F8	F9	FA	FB	FC	FD	FE	FF	

44XXU.068

## Extended Character Sets

Each internal font in the printer has a different character set associated with it as shown in the following tables. The hex codes accompany each character.

- Characters in Fonts**
- c0** 7 x 9 Standard
  - c1** 7 x 11 OCR
  - c2** 10 x 14 Standard
  - c7** 5 x 7 Standard

ML	SH	SH	EX	ET	EQ	RK	BL	BS	HT	LF	UT	FF	CR	SO	SI
00	01	02	03	04	05	06	07	08	09	0A	0B	0C	0D	0E	0F
DL	DI	DI	D3	D4	NK	SN	EB	CN	EM	SB	EC	FS	CS	RS	US
10	11	12	13	14	15	16	17	18	19	1A	1B	1C	1D	1E	1F
	!	!"	#	#\$	%	&	'	(	)	*	+	,	-	.	/
20	21	22	23	24	25	26	27	28	29	2A	2B	2C	2D	2E	2F
☐	1	2	3	4	5	6	7	8	9	:	;	<	=	>	?
30	31	32	33	34	35	36	37	38	39	3A	3B	3C	3D	3E	3F
@	A	B	C	D	E	F	G	H	I	J	K	L	M	N	O
40	41	42	43	44	45	46	47	48	49	4A	4B	4C	4D	4E	4F
P	Q	R	S	T	U	V	W	X	Y	Z	[	\	]	^	_
50	51	52	53	54	55	56	57	58	59	5A	5B	5C	5D	5E	5F
'	a	b	c	d	e	f	g	h	i	j	k	l	m	n	o
60	61	62	63	64	65	66	67	68	69	6A	6B	6C	6D	6E	6F
p	q	r	s	t	u	v	w	x	y	z	(	)	~	☐	
70	71	72	73	74	75	76	77	78	79	7A	7B	7C	7D	7E	7F
R	á	■	□	▲	△										
80	81	82	83	84	85	86	87	88	89	8A	8B	8C	8D	8E	8F
90	91	92	93	94	95	96	97	98	99	9A	9B	9C	9D	9E	9F
	i		¢	¤	¥		§	¨							
A0	A1	A2	A3	A4	A5	A6	A7	A8	A9	AA	AB	AC	AD	AE	AF
°															¿
B0	B1	B2	B3	B4	B5	B6	B7	B8	B9	BA	BB	BC	BD	BE	BF
				Æ	Œ	Æ			ƒ						
C0	C1	C2	C3	C4	C5	C6	C7	C8	C9	CA	CB	CC	CD	CE	CF
	Ž					Ö		Ø				Ü			ß
D0	D1	D2	D3	D4	D5	D6	D7	D8	D9	DA	DB	DC	DD	DE	DF
°				•	••	•••	••••	•••••	••••••		•••••••	••••••••			
E0	E1	E2	E3	E4	E5	E6	E7	E8	E9	EA	EB	EC	ED	EE	EF
	Œ	Ö				Ö		Ø	Ü			Ü			
F0	F1	F2	F3	F4	F5	F6	F7	F8	F9	FA	FB	FC	FD	FE	FF

44XXU.069



**Characters in Fonts**    *c20*                    **8 point**  
                                   *c21*                    **12 point**  
                                   *c22*                    **20 point**  
                                   *c25, c26, c28*       **outline fonts**  
                                   *c30-c41*               **monospace fonts (6 point to 36 point)**

Ø0	Ø1	Ø2	Ø3	Ø4	Ø5	Ø6	Ø7	Ø8	Ø9	ØA	ØB	ØC	ØD	ØE	ØF
10	11	12	13	14	15	16	17	18	19	1A	1B	1C	1D	1E	1F
20	!	"	#	\$	%	&	'	(	)	*	+	,	-	.	/
21	22	23	24	25	26	27	28	29	2A	2B	2C	2D	2E	2F	
30	0	1	2	3	4	5	6	7	8	9	:	;	<	=	>
31	32	33	34	35	36	37	38	39	3A	3B	3C	3D	3E	3F	
40	@	A	B	C	D	E	F	G	H	I	J	K	L	M	N
41	42	43	44	45	46	47	48	49	4A	4B	4C	4D	4E	4F	
50	P	Q	R	S	T	U	V	W	X	Y	Z	[	\	]	^
51	52	53	54	55	56	57	58	59	5A	5B	5C	5D	5E	5F	
60	`	a	b	c	d	e	f	g	h	i	j	k	l	m	n
61	62	63	64	65	66	67	68	69	6A	6B	6C	6D	6E	6F	
70	p	q	r	s	t	u	v	w	x	y	z	{		}	~
71	72	73	74	75	76	77	78	79	7A	7B	7C	7D	7E	7F	
80	€														
81	82	83	84	85	86	87	88	89	8A	8B	8C	8D	8E	8F	
90															
91															
92															
93															
94															
95															
96															
97															
98															
99															
A0		i	ç	£	¥		§	™	©	ª	«	¬	-	®	¯
A1	A2	A3	A4	A5	A6	A7	A8	A9	AA	AB	AC	AD	AE	AF	
B0	±	²	³	´	µ	¶	·	¸	¹	º	»	¼	½	¾	¿
B1	B2	B3	B4	B5	B6	B7	B8	B9	BA	BB	BC	BD	BE	BF	
C0	À	Á	Â	Ã	Ä	Å	Æ	Ç	È	É	Ê	Ë	Ì	Í	Î
C1	C2	C3	C4	C5	C6	C7	C8	C9	CA	CB	CC	CD	CE	CF	
D0	Ð	Ñ	Ò	Ó	Ô	Õ	Ö	×	Ø	Ù	Ú	Û	Ü	Ý	Þ
D1	D2	D3	D4	D5	D6	D7	D8	D9	DA	DB	DC	DD	DE	DF	
E0	à	á	â	ã	ä	å	æ	ç	è	é	ê	ë	ì	í	î
E1	E2	E3	E4	E5	E6	E7	E8	E9	EA	EB	EC	ED	EE	EF	
F0	ð	ñ	ò	ó	ô	õ	ö	÷	ø	ù	ú	û	ü	ý	þ
F1	F2	F3	F4	F5	F6	F7	F8	F9	FA	FB	FC	FD	FE	FF	

44XXU.070



**Note:** You cannot print these characters as 4 x 4 inch graphics because there is white space surrounding the characters that prevents the image from reaching the maximum graphic size.

Characters in Font c23 OCR A

00	01	02	03	04	05	06	07	08	09	0A	0B	0C	0D	0E	0F
10	11	12	13	14	15	16	17	18	19	1A	1B	1C	1D	1E	1F
	!	"	#	\$	%	&	'	(	)	*	+	,	-	.	/
20	21	22	23	24	25	26	27	28	29	2A	2B	2C	2D	2E	2F
0	1	2	3	4	5	6	7	8	9	:	;	<	=	>	?
30	31	32	33	34	35	36	37	38	39	3A	3B	3C	3D	3E	3F
Q	A	B	C	D	E	F	G	H	I	J	K	L	M	N	O
40	41	42	43	44	45	46	47	48	49	4A	4B	4C	4D	4E	4F
P	Q	R	S	T	U	V	W	X	Y	Z	[	\	]	^	_
50	51	52	53	54	55	56	57	58	59	5A	5B	5C	5D	5E	5F
h	a	b	c	d	e	f	g	h	i	j	k	l	m	n	o
60	61	62	63	64	65	66	67	68	69	6A	6B	6C	6D	6E	6F
p	q	r	s	t	u	v	w	x	y	z	{		}	~	■
70	71	72	73	74	75	76	77	78	79	7A	7B	7C	7D	7E	7F
80	81	82	83	84	85	86	87	88	89	8A	8B	8C	8D	8E	8F
90	91	92	93	94	95	96	97	98	99	9A	9B	9C	9D	9E	9F
A0	A1	A2	£	A4	¥	A6	A7	A8	A9	AA	AB	AC	AD	AE	AF
B0	B1	B2	B3	B4	B5	B6	B7	B8	B9	BA	BB	BC	BD	BE	BF
C0	C1	C2	C3	Ä	Å	Æ	C7	C8	C9	CA	CB	CC	CD	CE	CF
D0	Š	D2	D3	D4	ö	D6	ø	D8	DA	DB	Ü	DD	DE	DF	
E0	E1	E2	E3	E4	E5	E6	E7	E8	E9	EA	EB	EC	ED	EE	EF
F0	F1	F2	F3	F4	F5	F6	F7	F8	F9	FA	FB	FC	FD	FE	FF

44XXU.071





Characters in Font c24 OCR B Size 2

00	01	02	03	04	05	06	07	08	09	0A	0B	0C	0D	0E	0F
10	11	12	13	14	15	16	17	18	19	1A	1B	1C	1D	1E	1F
20	!	"	#	\$	%	&	'	(	)	*	+	,	-	.	/
30	0	1	2	3	4	5	6	7	8	9	:	;	<	=	>
40	@	A	B	C	D	E	F	G	H	I	J	K	L	M	N
50	P	Q	R	S	T	U	V	W	X	Y	Z	[	\	]	^
60	`	a	b	c	d	e	f	g	h	i	j	k	l	m	n
70	p	q	r	s	t	u	v	w	x	y	z	{		}	~
80															
90															
A0			£	¤	¥	¦	§	¨							
B0			'				'								
C0			À	Á	Æ										
D0	Ñ				Ö		Ø					Ü			ß
E0				ä	å	æ									
F0	ñ				ö		ø					ü			

44XXU.072





# ***Communications Reference***



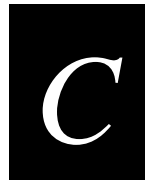

## Communication Protocols

---

Communication protocols are important because they determine the transmission standards for communication between the printer and the host. The printer and the host must use the same protocol and parameters to communicate properly. The printer supports the flow control and block transfer protocols described in the next sections. All of these protocols are point-to-point except Multi-Drop. Application programs and/or ROM BIOS determine which protocols your computer can support. For more detailed information, refer to the Intermec *Data Communications Reference Manual* (Part No. 044737).

### Intermec Standard Protocol

Intermec Standard protocol is a proprietary block transfer/status response protocol. For each block sent, the host must wait for the appropriate response before sending the next block (<DC1>). Except for single character status commands (<ENQ> and <VT>), Standard protocol transmits characters in message blocks beginning with the start of text (<STX>) character and ending with the end of text (<ETX>) character. Message blocks can be up to 255 characters, including the start of text and end of text characters. The printer auto-discriminates between Standard, Polling Mode D, and Multi-Drop protocols.

The printer returns its highest priority status when it receives a valid block (<STX> data <ETX>) or when it receives the status request command <ENQ>. When the printer receives the status dump command (<VT>), the printer returns all active status. The printer status response time ranges from 30ms to 100ms depending on the complexity of the received message block. In the case of a transmission error, the printer responds with a <NAK> and discards the entire message block.

The table below shows printer status conditions in descending order of priority, status response characters, and pin 11/20 states:

Printer Status	Character	Pin 11/20
Buffer already full	GS	Busy
Ribbon fault	US	Busy
No label stock	EM	Busy
Buffer now full	DC3	Busy
Printhead hot	SI	Busy
Offline (paused)	DC3	Busy
Label at strip pin	FS	Ready
Skipping	DC1	Ready
Printing	DC1	Ready
Ready/Online	DC1	Ready



**Note:** Do not confuse the Buffer now full <DC3> status with the XON/XOFF characters <DC1> and <DC3>.

When the printer returns Buffer Now Full (<DC3>) status, it accepts the currently received message block. At this time, the printer can accept short messages to allow parsing of immediate commands such as Reset (<DLE>) or Cancel Batch Printing (<EM>). However, if the printer responds with a <GS> to any message block, the buffer is already full and the printer discards the entire message block.

---

### **XON/XOFF Protocol (Software and Hardware Flow Control)**

The XON/XOFF protocol stops the host from sending data when the printer buffer fills up and starts the host again when the buffer empties. When you select this protocol, you concurrently enable software and hardware flow control. Software flow control uses the ASCII characters <DC1> (XON) and <DC3> (XOFF) to start and stop the flow of data from the host to the printer. Hardware flow control uses pin 11 or pin 20 (internally connected together) on the printer's serial port to indicate "Ready" or "Busy" for data flow control. As with Standard protocol, <STX> and <ETX> enclose data. Status responses conform to the table above except that <DC2> is substituted for <DC1> and <DC4> is substituted for <DC3>.

The printer does not restrict the message length for XON/XOFF protocol. That is, the printer processes information as it is being downloaded and stops when there is no more information. There is no restriction on the number of characters that can be sent down at a time. <STX> and <ETX> are optional characters.

Pin 11/20 reports "Ready" and a <DC1> (XON) is transmitted when the printer finishes reloading at power-up. Pin 11/20 reports "Busy" when the printer's input buffer fills with 768 bytes of data. If the host ignores pin 11/20 and continues to transmit data, the printer transmits a <DC3> (XOFF) after receiving 15 additional characters. The printer continues to transmit a <DC3> after every 15 characters received if the host continues to transmit data. Data integrity is not guaranteed if this happens.

Pin 11/20 becomes "Ready" when the printer has transferred all the data from the input buffer. If the printer receives a <DC3>, it transmits a <DC1> (XON) and the host may resume transmission. When you switch the printer offline, pin 11/20 becomes "Busy" and it transmits a <DC3>. When you switch the printer online (and the input buffer is empty), pin 11/20 becomes "Ready" and it transmits a DC1.

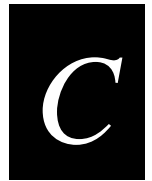

This table shows the printer XON/XOFF operation:

# of Bytes Received	Online/Offline	Pin 11/20	Transmit
Do not care	Offline	Busy	DC3
768	Online	Busy	
768 + each 15 thereafter	Online	Busy	DC3
Buffer Empty	Online	Ready	DC1 (if DC3 was sent)

---

### ***XON/XOFF, No Status Protocol***

This protocol is identical to XON/XOFF protocol except that status is not returned after each message received. However, status is still returned for the status request (<ENQ>) and the status dump (<VT>) commands.

---

### ***Polling Mode D***

Polling Mode D is a block transfer protocol that transmits data in blocks of up to 255 characters, including protocol overhead. For Polling Mode D, the host/concentrator is responsible for asking the printer for data it might have (polling) and requesting to send data to the printer (selecting). The blocks are framed with LRC characters for additional data integrity. Polling Mode D is normally used for point-to-point networks that connect the printer to an Intermec port concentrator (RS-232 or RS-422 are acceptable).

This protocol is the default setting for the printer. Return the protocol setting to Polling Mode D by setting the printer DIP switches to the factory default settings (9600, E, 7, 1).

---

### ***Multi-Drop Protocol***

Use Multi-Drop protocol to connect up to 32 devices to an Intermec controller on a four-wire RS-485 (two twisted pair). This protocol is similar to Polling Mode D except each device has a unique address (POL and SEL character). You must use an RS-485, which is automatically enabled when you enable Multi-Drop. Be sure to specify a unique address for the printer and verify that the baud rate is between 2,400 and 19,200.

---

### ***User-Defined Protocol***

The printer provides the capability to change protocol characters. However, the user may not define their own protocol. You can substitute characters you want to use as protocol characters, but the rules for the chosen protocol do not change. The printer does not use any protocol characters that you replace with the NUL character. One table of protocol characters exists. You may redefine these characters to create a table that all of the protocols can use. One possibility for the user to redefine protocol characters might be the replacement of control characters with printable characters.



**Note:** Please use caution when replacing control characters with printable characters. You cannot replace one control character with more than one printable character.

The following table lists the protocol characters that you can redefine and the protocols they affect:

Character	Protocol Affected
SELECT IN	POL MODE D, MULTI-DROP
POLL IN	POL MODE D, MULTI-DROP
RES IN	POL MODE D, MULTI-DROP
REQ IN	POL MODE D, MULTI-DROP
SOM IN	STD, POL MODE D, MULTI-DROP, XON/XOFF
EOM IN	STD, POL MODE D, MULTI-DROP, XON/XOFF
AFF IN	POL MODE D, MULTI-DROP
NEG IN	POL MODE D, MULTI-DROP
DLE IN	STD, POL MODE D, MULTI-DROP, XON/XOFF
XON IN	XON/XOFF
XOFF IN	XON/XOFF
SELECT OUT	MULTI-DROP
POLL OUT	MULTI-DROP
RES OUT	POL MODE D, MULTI-DROP
REQ OUT	POL MODE D, MULTI-DROP
SOM OUT	POL MODE D, MULTI-DROP
EOM OUT	POL MODE D, MULTI-DROP
AFF OUT	POL MODE D, MULTI-DROP
NEG OUT	STD, POL MODE D, MULTI-DROP
DLE OUT	STD, POL MODE D, MULTI-DROP
XON OUT	XON/XOFF
XOFF OUT	XON/XOFF
PROTO-CMD 1	STD, XON/XOFF
PROTO-CMD 2	STD, XON/XOFF
TIMEOUT ON EOM	POL MODE D, MULTI-DROP



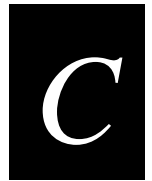

---

## **Host Requirements**

Your printer has the following hardware and software requirements:

- The host computer must use the American Standard Code for Information Exchange (ASCII) for data communications.
- A serial port must be available on the host if you are connecting directly to the printer.
- The host must support at least one of the following data communications interfaces: RS-232, RS-422, or RS-485.

For information on configuring the host computer, port concentrator, or network controller, see the reference manual for the controlling device.

---

## **Communications Boundaries**

The information below applies to all protocols that the printer supports.

<b>Parameter</b>	<b>Maximum Capacity</b>
Message delay	9999 milliseconds
Character delay	9999 milliseconds
Message block size	255 characters (including STX and ETX characters) Unlimited block size for XON/XOFF
Device address number (Multi-Drop only)	A to Z, 0 to 5

---

## **Communications Interfaces**

The printer supports serial communications with the following interfaces:

- RS-232
- RS-422
- RS-485

The following sections describe these interfaces. See the *Data Communications Reference Manual* (Part No. 044737) for more detailed information.

---

### **RS-232 Serial Interface**

Use the RS-232 serial interface in all asynchronous point-to-point full- or half-duplex direct data communications or modem control. The printer cable must have the pin assignments for an RS-232 serial interface shown in the table on the next page.

---

## **RS-422 Serial Interface**

Use the RS-422 interface in long line point-to-point direct connect installations. The printer cable must have the pin assignments for an RS-422 serial interface shown in the table on this page.

---

## **RS-485 Serial Interface**

Use the RS-485 serial interface for Multi-Drop installations only. The printer cable must have the pin assignments for an RS-485 serial interface shown in the table on this page.

Interface	Pin No.	Name	Operation
RS-232/422/485	1	Chassis Ground (GND)	Connect to pin 1, chassis ground, of connected device.
RS-232	2	Transmit Data (TD)	Output: Connect to receive data pin of connected device.
RS-232	3	Receive Data (RD)	Input: Connect to transmit data pin of connected device.
RS-232/422/485	4	Request to Send (RTS)	Output: When you use a modem, connect to modem RTS pin. The modem sets RTS to true before transmission. The printer sets RTS to false after transmission.
RS-232/422/485	5	Clear to Send (CTS)	Input: When you use a modem, connect to modem CTS pin. The modem must set CTS true before the printer transmits data. If not connected, CTS sets itself true.
RS-232/422/485	7	Signal Ground (SG)	To enable communications, connect to signal ground of connected device. Completes circuit for all RS-232 signals.
RS-232/422/485	11	Printer Status (PS)	Output: When not using software flow control (XON/XOFF), connect to input of connected device (for example, CTS). Indicates printer mechanical status and status of printer input buffer.
RS-422/485	13	Input B	Input: Serial differential data to the printer.
RS-422/485	14	Output A	Output: Serial differential data from the printer.
RS-422/485	16	Input A	Input: Serial differential data to the printer.
RS-422/485	19	Output B	Output: Serial differential data from the printer.
RS-232/422/485	20	Data Terminal Ready (DTR)	Output: When you use a modem, connect to modem DTR pin.

When using Intermec Standard Protocol, this pin indicates that the printer is switched on.

When using XON/XOFF or hardware flow control, this pin indicates the printer mechanical status and the status of the printer input buffer.

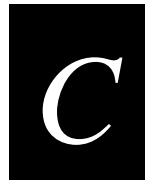

**RS-232 Null Modem Cable for PC/XT (Part Number 048668)**

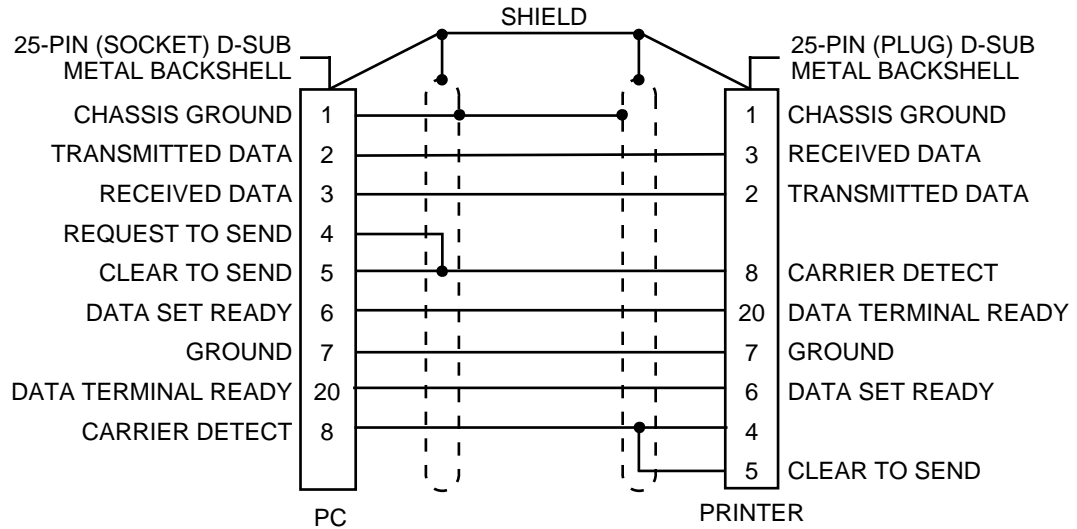

NOTE: The metal backshell is connected directly to the shield to achieve electrostatic discharge (ESD) immunity.

3XXXU.010

**RS-232 Null Modem Cable for PC/AT (Part Number 048693)**

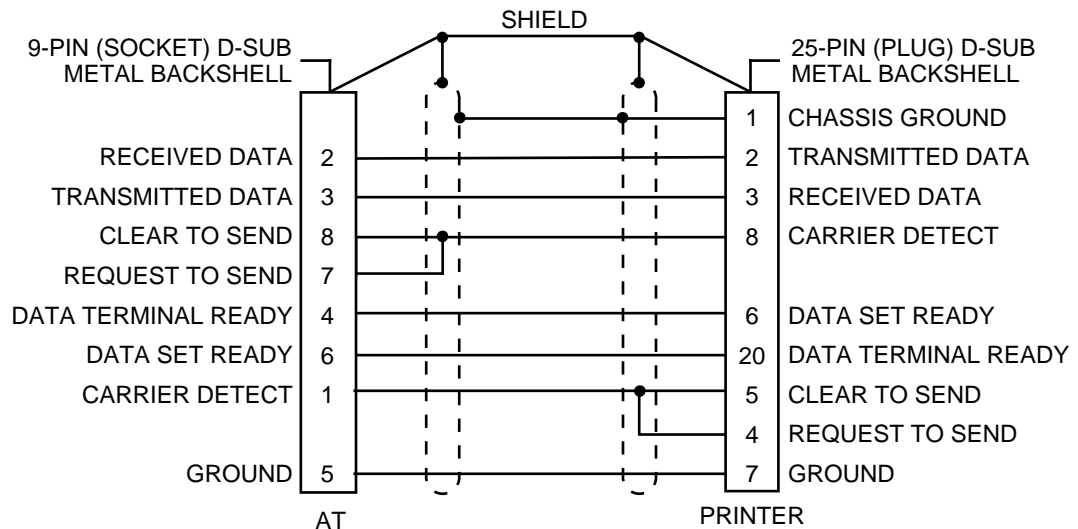

NOTE: The metal backshell is connected directly to the shield to achieve electrostatic discharge (ESD) immunity.

3XXXU.011

**Straight Through DTE to DCE Cable for Use with a Modem (Part Number 043237S)**

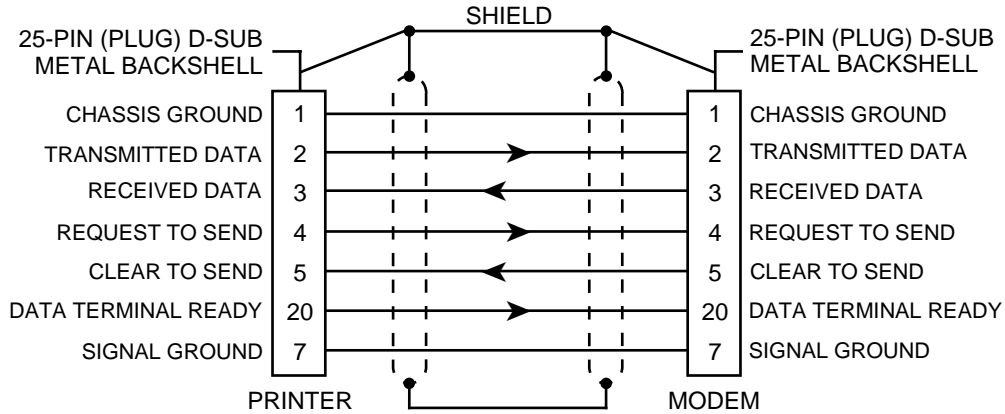

NOTE: The metal backshell is connected directly to the shield to achieve electrostatic discharge (ESD) immunity.

3XXXU.012



**Note:** If you find that you are losing data, you may need to isolate the chassis ground from one of the two devices by connecting it to the shield.

**RS-422 Intermec Pin Assignments**

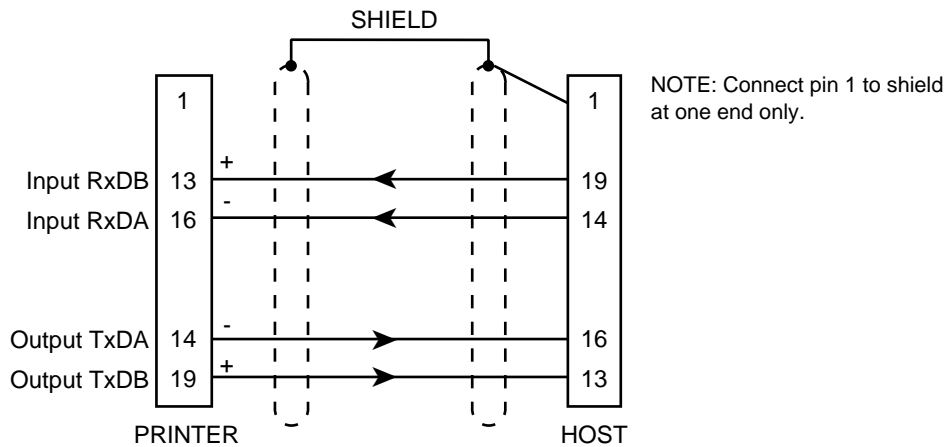

NOTE: Connect pin 1 to shield at one end only.

3XXXU.013



**Note:** The host in this case includes Intermec products that support RS-422. Non-Intermec controllers may have different pin assignments.

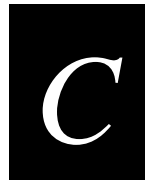

## Printer Serial Port

The rear panel of the printer contains the serial port connector. It is a 25-pin D-style subminiature receptacle. The port is wired as a data terminal equipment (DTE) device. Refer to the following figure for pin names on the serial port:

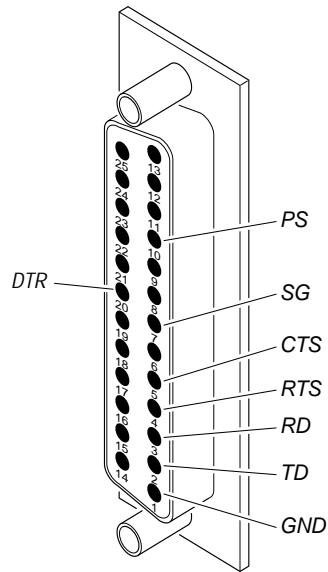

3XXXU.063





## ***Full ASCII Table***





## Full ASCII Table

Binary <sup>0</sup>	Hex <sup>1</sup>	Dec <sup>2</sup>	C39 <sup>3</sup>	Char <sup>4</sup>	Binary <sup>0</sup>	Hex <sup>1</sup>	Dec <sup>2</sup>	C39 <sup>3</sup>	Char <sup>4</sup>
00000000	00	00	%U	NUL	00100000	20	32	SP	SP <sup>5</sup>
00000001	01	01	\$A	SOH	00100001	21	33	/A	!
00000010	02	02	\$B	STX	00100010	22	34	/B	"
00000011	03	03	\$C	ETX	00100011	23	35	/C	#
00000100	04	04	\$D	EOT	00100100	24	36	/D	\$
00000101	05	05	\$E	ENQ	00100101	25	37	/E	%
00000110	06	06	\$F	ACK	00100110	26	38	/F	&
00000111	07	07	\$G	BEL	00100111	27	39	/G	'
00001000	08	08	\$H	BS	00101000	28	40	/H	(
00001001	09	09	\$I	HT	00101001	29	41	/I	)
00001010	0A	10	\$J	LF	00101010	2A	42	/J	*
00001011	0B	11	\$K	VT	00101011	2B	43	/K	+
00001100	0C	12	\$L	FF	00101100	2C	44	/L	,
00001101	0D	13	\$M	CR	00101101	2D	45	/M	-
00001110	0E	14	\$N	SO	00101110	2E	46	/N	.
00001111	0F	15	\$O	SI	00101111	2F	47	/O	/
00010000	10	16	\$P	DLE	00110000	30	48	/P <sup>6</sup>	0
00010001	11	17	\$Q	DC1	00110001	31	49	/Q	1
00010010	12	18	\$R	DC2	00110010	32	50	/R	2
00010011	13	19	\$S	DC3	00110011	33	51	/S	3
00010100	14	20	\$T	DC4	00110100	34	52	/T	4
00010101	15	21	\$U	NAK	00110101	35	53	/U	5
00010110	16	22	\$V	SYN	00110110	36	54	/V	6
00010111	17	23	\$W	ETB	00110111	37	55	/W	7
00011000	18	24	\$X	CAN	00111000	38	56	/X	8
00011001	19	25	\$Y	EM	00111001	39	57	/Y	9
00011010	1A	26	\$Z	SUB	00111010	3A	58	/Z	:
00011011	1B	27	%A	ESC	00111011	3B	59	%F	;
00011100	1C	28	%B	FS	00111100	3C	60	%G	<
00011101	1D	29	%C	GS	00111101	3D	61	%H	=
00011110	1E	30	%D	RS	00111110	3E	62	%I	>
00011111	1F	31	%E	US	00111111	3F	63	%J	?

Full ASCII Table (continued)

Binary <sup>0</sup>	Hex <sup>1</sup>	Dec <sup>2</sup>	C39 <sup>3</sup>	Char <sup>4</sup>	Binary <sup>0</sup>	Hex <sup>1</sup>	Dec <sup>2</sup>	C39 <sup>3</sup>	Char <sup>4</sup>
01000000	40	64	%V	@	01100100	64	100	+D	d
01000001	41	65	A	A	01100101	65	101	+E	e
01000010	42	66	B	B	01100110	66	102	+F	f
01000011	43	67	C	C	01100111	67	103	+G	g
01000100	44	68	D	D	01101000	68	104	+H	h
01000101	45	69	E	E	01101001	69	105	+I	i
01000110	46	70	F	F	01101010	6A	106	+J	j
01000111	47	71	G	G	01101011	6B	107	+K	k
01001000	48	72	H	H	01101100	6C	108	+L	l
01001001	49	73	I	I	01101101	6D	109	+M	m
01001010	4A	74	J	J	01101110	6E	110	+N	n
01001011	4B	75	K	K	01101111	6F	111	+O	o
01001100	4C	76	L	L	01110000	70	112	+P	p
01001101	4D	77	M	M	01110001	71	113	+Q	q
01001110	4E	78	N	N	01110010	72	114	+R	r
01001111	4F	79	O	O	01110011	73	115	+S	s
01010000	50	80	P	P	01110100	74	116	+T	t
01010001	51	81	Q	Q	01110101	75	117	+U	u
01010010	52	82	R	R	01110110	76	118	+V	v
01010011	53	83	S	S	01110111	77	119	+W	w
01010100	54	84	T	T	01111000	78	120	+X	x
01010101	55	85	U	U	01111001	79	121	+Y	y
01010110	56	86	V	V	01111010	7A	122	+Z	z
01010111	57	87	W	W	01111011	7B	123	%P	{
01011000	58	88	X	X	01111100	7C	124	%Q	
01011001	59	89	Y	Y	01111101	7D	125	%R	}
01011010	5A	90	Z	Z	01111110	7E	126	%S	~
01011011	5B	91	%K	[	01111111	7F	127	%T <sup>7</sup>	n <sup>8</sup>
01011100	5C	92	%L	\					
01011101	5D	93	%M	]					
01011110	5E	94	%N	^					
01011111	5F	95	%O	_					
01100000	60	96	%W	`					
01100001	61	97	+A	a					
01100010	62	98	+B	b					
01100011	63	99	+C	c					

Notes:

- 0 Bit positions are 76543210.
- 1 Hexadecimal value
- 2 Decimal value
- 3 Code 39 character(s)
- 4 ASCII character
- 5 SP is the SPACE character.
- 6 The Code 39 characters /P through /Y may be interchanged with the numbers 0 through 9.
- 7 May be interchanged with %X or %Y or %Z.
- 8 n is the DELETE character.

## Full ASCII Control Characters Table

---

Control Character	Definition	Control Character	Definition
ACK	Acknowledgment	FF	Form Feed
BEL	Bell	FS	File Separator
BS	Backspace	GS	Group Separator
CAN	Cancel	HT	Horizontal Tab
CR	Carriage Return	LF	Line Feed
DC1	Device Control 1 (XON)	NAK	Negative Acknowledge
DC2	Device Control 2	NUL	Null, or all zeroes
DC3	Device Control 3 (XOFF)	RS	Record Separator
DC4	Device Control	SI	Shift In
DEL	Delete	SO	Shift Out
DLE	Data Link Escape	SOH	Start of Heading
EM	End of Medium	SP	Space
ENQ	Enquiry	STX	Start of Text
EOT	End of Transmission	SUB	Substitute
ESC	Escape	SYN	Synchronous Idle
ETB	End Transmission Block	US	Unit Separator
ETX	End of Text	VT	Vertical Tab





## ***Glossary***



***ASCII***

American Standard Code for Information Interchange. A standard seven bit code almost always transmitted with a parity bit for a total of eight bits per character. ASCII was established by the American National Standards Institute to achieve compatibility between various types of data communication equipment. Equivalent to the International ISO 7-bit code.

***backing***

Silicon release liner on media to which labels are attached until ready for use.

***bar code***

A printed, machine-readable code that consists of parallel bars of varied width and spacing.

***batch takeover***

A device that rewinds media; useful for printing batches of labels.

***BEL***

A command character that instructs the printer to return an error status code.

***character set***

Refers to the letters, numerals, and symbols that support a particular language (such as French, U.S., ASCII) or automatic identification technology (such as Code 30, Codabar).

***cloning***

A procedure that copies the RAM contents (configuration, formats, fonts, pages and graphics) from the memory of one printer to the memory of another.

***configuration***

The current parameter settings that determine the operating characteristics of the printer.

***data file***

The collection of data and printer commands that, when sent to the printer, is merged with a format file to print a label.

***Data Line Print mode***

A mode of operation in which the printer prints each command (accompanied by its ASCII code) that it receives from the host.

***density***

Number of data characters that can be represented in a linear unit of measure. Often expressed in characters per inch.

***direct thermal***

A method of thermal printing in which images are printed when heat from the thermal printhead produces a black mark on the media.

***EAN***

European Article Numbering; now also called IAN (International Article Numbering). International standard bar code for retail food packages corresponding to the Universal Product Code (UPC) in the United States.

***Emulation mode***

An operating mode in which the printer has the operating characteristics of an 8636 or 8646 printer.

***Feed/Pause***

A printer control panel button that advances the media and causes the printer to pause printing.

***field***

A graphic element that is the basic unit of a format. The four basic types of fields are bar code, graphic, line, and text.

***fixed data field***

Bar code and text fields that never vary from one label to the next; the data in a fixed field is a permanent part of the format.

***fixed format***

A format in which the data never varies from one label to the next, such as a return address label. A fixed format needs no additional data to print a label.

***font***

A character set of a given type size and style. See also character set.

***font file***

See soft font.

***format file***

a collection of printer commands and data that determines the arrangement of fields on a label.



***graphic***

A bitmap picture downloaded to the printer by the host before printing.

***HIBC***

Health Industry Bar Code standard. A modified version of Code 39 that has 43 characters, utilizes the Modulus 43 check character, and reserves some character combinations for special usage.

***human-readable***

A character, number, or symbol printed in a font that can be read by a human; as opposed to bar code symbology, which can only be read by a machine. See text.

***image bands***

A portion of an image in the shape of a strip of the image. A certain number of image bands are stored in memory before printing begins. This method allows printing and imaging to take place simultaneously.

***imaging***

The process of generating a picture of the label in printer memory.

***ips***

Inches per second. A measurement of print speed that measures the number of inches of media that is printed each second.

***ISO***

International Organization for Standardization. An internationally accepted 7-bit character code. (The U.S. version is ASCII.)

***label***

The part of the media on which data is printed.

***label format***

The design of a bar code label; the arrangement of the text, lines, and bar codes on a label.

***label gap***

The space between labels on die-cut label stock.

***ladder***

A method of bar code printing in which the bars in the bar code print one at a time, in a series. The bar code appears along the length of the label.

***margin***

The distance between the edge of a label and where the printing starts on that label. *See also* top of form.

***media***

The label stock on which the printer prints labels. Media can be made of plain paper, polyester, thermally reactive paper, or other materials with adhesive backing and ribbon.

***mnemonic code***

An acronym or abbreviation for a computer instruction, routine, or format. For example, <STX> represents the start of text.

***Multi-Drop protocol***

A protocol capable of controlling communications between a single controller and multiple devices.

***OCR font***

A font that is recognized by optical character recognition.

***offline***

The state in which the printer is not able to carry out two-way communication with the host.

***online***

The state in which the printer is able to carry out two-way communication with the host.

***parallel***

A communication scheme in which the bits of a byte are transferred simultaneously over a multistrand cable.

***parameters***

The operating limits of the printer. Also, the variable information sent with a command.

***picket***

A method of bar code printing in which all the bars are printed at once, in parallel. The bar code appears across the width of the label.

***pitch***

(1) The number of characters printed in one horizontal inch determined by the increment by which the printer platen moves. (2) Rotation of a bar code symbol about an axis parallel to the direction of the bars.

***point size***

A unit of measure for font height; 72 points equals 1 inch as measured from slightly above the top of the uppercase letters to slightly below the bottom of the lowercase descenders.

***Polling Mode D protocol***

Polling Mode D is a protocol that allows devices and controllers to exchange data in an “ask and receive” format. Use Polling Mode D to connect multiple devices to a single multiport controller.

***print speed***

Measured in inches per second (ips), the rate at which media travels past the printhead.

***printhead***

The mechanism inside the printer that prints. For example, the printhead for the 3440 printer consists of 1792 thermal elements.

***printhead elements***

The parts of the printhead that print by placing a mark on the label when heated. Each element is switched on and off separately in order to react with the media or thermal transfer ribbon to create a mark on the label.

***ready***

The state in which the printer is able to print; the normal operating state of the printer.

***Ready/Busy line***

Pin 11/20 of the rear panel connector. Indicates the printer is ready or not ready.

***RS-232***

Widely recognized protocol standard for serial binary data interchange. The standard covers the physical, electrical, and functional characteristics of the interface.

***RS-422***

Standard for the voltage and impedance levels for serial data transmission on balanced lines. Similar to RS-232, but handles larger distances and faster communication.

***RS-485***

Standard for allowing multiple devices to share a common set of serial data communication lines. The signaling is very similar to RS-422. The maximum number of devices allowed is 32.

***scan***

To read a bar code with a device known as a scanner that converts optical information into electrical signals.

***selective transfer***

A procedure that copies selected formats, fonts, graphics, or pages stored in the memory of one printer to the memory of another.

***self-strip***

An internal device for the printer that presents each label after it is printed, with the backing removed so it may be applied immediately. Self-strip is a standard feature on the 3400e printer.

***sensitivity***

The responsiveness of thermal media, or of thermal transfer ribbon, to heat; it is determined by the time required for a unit measure of heat to affect the media or ribbon.

***serial***

A communication scheme in which the bits of a byte are transferred one at a time. Often serial transmission is used to link host computers to terminals and PCs to printers.

***soft font***

A file stored in the printer to provide the ability to print text using fonts that are not resident in the printer.

***Standard protocol***

A communications protocol capable of controlling communications between two devices connected by a single data communication line.

***symbology***

A scheme for encoding data as a bar code. Code 39, Interleaved 2 of 5, and Code One are examples of different symbologies.

***thermal transfer***

A method of printing by which heat from the printhead melts ink from the ribbon onto media. The ink adheres to the media as it cools.

***top of form***

The point where printing can start on a label. Separated from the edge of the label by the margin.

***UPC***

Universal Product Code. A numeric, 12-digit bar code symbology used extensively in retail, particularly the grocery industry.

***User-Defined Characters (UDC)***

See graphic.

***User-Defined Fonts (UDF)***

See soft font.

***variable data field***

Bar code and text fields that change from one label to the next.

***XON/XOFF protocol***

A protocol that stops the host from sending data when the printer buffer fills up and starts it again when the buffer empties.





***Index***





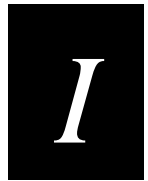

## Numbers

### 2D symbologies, A-9

- Code 16K, A-9
- Code 49, A-9
- Data Matrix, A-10
- Maxicode, A-10
- PDF417, A-9

### 86XX Emulation mode, 6-11

## A

### AC power receptacle, 1-5

#### adjustments

- bias adjust screw, 5-3
- darkness adjust control, 5-5
- label mark sensor, 5-6
- X forms adjust, 6-13
- Y forms adjust, 6-14

### Advanced mode, international character sets, B-3

### AS400, connecting to the 3400, 1-13

#### ASCII

- control characters, list of, D-5
- table, D-3

## B

### bands, image, 5-9

#### bar code symbologies

- Codabar, A-8
- Code 11, A-8
- Code 128, A-8
- Code 2 of 5, A-8
- Code 39, A-8
- Code 93, A-8
- EAN, A-8
- Interleaved 2 of 5, A-8
- list of, A-8
- POSTNET, A-8
- UPC, A-9

#### bias adjust screw

- adjusting, 5-3
- using for optimal print quality, 5-3

#### boundaries, communication, C-7

## C

#### cables

- considerations in noisy electrical environments, 1-14
- RS-232 schematics, C-9
- RS-422 schematic, C-10
- serial port, 1-11
- straight through schematics, C-10

#### changing serial port settings, 1-16

#### character sets, A-4

- Advanced mode, B-3
- Code Page 850, B-5
- Emulation mode, B-4

#### character sets (*continued*)

- extended, B-6
- IBM translation, B-4
- international, B-3

#### cleaning

- drive roller, 3-8
- label sensors, 3-10
- media guides, 3-9
- media path, 3-9
- printer covers, 3-7
- printhead, 3-6
- schedule, 3-4
- tear bar, 3-8
- tools, 3-3

#### coax interface option, A-6

#### Codabar, A-8

#### Code 11, A-8

#### Code 128, A-8

#### Code 16K, A-9

#### Code 2 of 5, A-8

#### Code 39, A-8

#### Code 49, A-9

#### Code 93, A-8

#### Code Page 850, character table, B-5

#### communicating with the printer

- using PrintSet, 2-16
- using the printer command set, 2-16
- using third-party software, 2-16

#### communications

- boundaries, C-7
- host requirements, C-7
- interfaces, C-7
- IPL commands, using, 2-16
- PrintSet, using, 2-16
- protocols, C-3
  - Multi-Drop, C-5
  - Polling Mode D, C-5
  - Standard, C-3
  - user-defined, C-5
  - XON/XOFF, C-4, C-5

#### specifications, A-3

#### testing for, 1-17, 2-17

#### third-party software, using, 2-16

#### troubleshooting, 4-7, 6-5

#### configuration

#### printing test label, 2-17, 6-5

#### test label

- hardware, 1-9
- software, 2-13

#### configuration commands

#### changing from Test and Service mode, 6-6

#### Emulation mode, 6-11

#### X forms adjust, 6-13

#### Y forms adjust, 6-14

#### DIP switch settings, 6-7

## EasyCoder 3400e Bar Code Label Printer User's Manual

configuring the serial port, 1-15

connecting

printer to a mainframe, 1-14

printer to a network, 1-12

printer to a PC

using the parallel port, 1-12

using the serial port, 1-11

printer to an AS400, 1-13

printer to system

using the parallel port, 1-10

using the serial port, 1-10

control characters, full ASCII, D-5

conventions used in manual, xii

cover

cleaning, 3-7

removing, 1-6

### D

darkness adjust control

setting, 5-5

using for optimal print quality, 5-5

Data Line Print, 6-5

entering, 6-5

using to test the operation of the printer, 6-5

using to troubleshoot printer, 6-5

data loss

checking for communication problems, 4-8

preventing, 4-7

Data Matrix, A-10

dimensions, A-3

DIP switch settings

changing, 1-15

configuration commands, 6-7

dot increments, moving, 6-8

Emulation mode, setting, 6-11

label rest point, adjusting, 6-10

table, serial port, 1-16

test and service, 6-4

dot increments, setting the number of, 6-9

downloading

definition, 2-16

drive roller, cleaning, 3-8

### E

EAN, A-8

electrical requirements, A-3

Emulation mode

international character sets, B-4

setting, 6-11

environment, specifications, A-3

extended character sets, B-6

### F

fanfold media, loading, 1-7

faults

media or system, 2-4

Feed/Pause button

functions of, 2-5

illustrated, 2-3

using, 2-5

flash SIMM, additional storage memory, 5-8

flow control, C-4

font tables, extended character sets, B-6

fonts and graphics, A-4

fonts, extended character sets, B-6

formats

positioning with DIP switches, 6-12

forms adjust

positioning the label format, 6-12

X forms, setting, 6-13

Y forms, setting, 6-14

front panel

LEDs, 2-4

understanding, 2-3

full ASCII table, D-3

### G

graphics, A-4

### H

hardware configuration test label

example, 1-9

printing, 1-9

host requirements, communications, C-7

### I

IBM translation, character table, B-4

image bands

description, 5-9

function, 5-10

optimizing with print speed, 5-10

increasing printer throughput, 5-9

inspecting the printer, 3-3

installation

network, 1-13

printer, 1-5

interfaces

communications, C-7

RS-232, C-7

RS-422, C-8

RS-485, C-8

Interleaved 2 of 5, A-8

Intermec Standard protocol, C-3

international character sets, B-3

IPL commands, using to communicate, 2-16

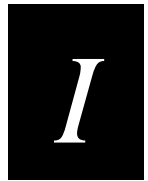

## L

- label
  - format
    - positioning along the length of label, 6-13
  - format
    - positioning parallel along width of label, 6-14
  - mark sensor, adjusting, 5-6
  - rest point
    - adjusting with DIP switches, 6-10
    - setting dot increments, 6-7
    - sensors, cleaning, 3-10
- languages, international character sets, B-3
- LED
  - front panel, 2-4
  - indicators, 2-4
  - media or system faults, 2-4
  - over-temperature condition, 2-4
  - understanding, 2-4
- loading
  - fanfold media, 1-7
  - media for straight-through printing, 2-6
  - roll media, 2-6

## M

- mainframe, connecting to the 3400, 1-14
- maintenance, schedule, 3-4
- Maxicode, A-10
- media
  - guides, cleaning, 3-9
  - loading fanfold, 1-7
  - loading in the printer, 2-6
  - path, cleaning, 3-9
- media or system faults, 2-4
- media sensitivity number
  - description of, 2-12
  - setting for Intermec media and ribbon, 2-13
  - settings table
    - direct thermal media, 2-14
- media specifications, A-5
- memory
  - additional storage, flash SIMM, 5-8
  - increasing amount available, 5-9
  - increasing amount available in printer, 6-6
  - limitations, 5-8
  - resetting, 6-6
  - returning printer to default settings, 6-6
  - usage
    - limitations, 5-8
    - problems, 5-8
    - using efficiently, 5-8
- Multi-Drop protocol, C-5

## N

- network
  - connecting to the 3400, 1-12

- network (*continued*)
  - installation, 1-13

## O

- On/Off switch, 1-5
- opening the printer, 1-6
- options
  - communication interface, A-6
  - finishers, A-6
  - printer, A-6
- over-temperature condition, 2-4

## P

- parallel interface, pin descriptions, A-7
- parallel port, using to connect the 3400 to a PC, 1-12
- PDF417, A-9
- pin descriptions, parallel interface, A-7
- pitch test label, printing, 6-5
- plugging in the printer, 1-5
- Polling Mode D protocol, C-5
- POSTNET, A-8
- print quality
  - correcting, 5-3
  - darkness adjust control, adjusting with, 5-5
  - maintaining, 5-3
  - optimizing, 5-3
  - printing test label, 6-5
  - troubleshooting, 4-5
  - understanding, 5-3
- print speed, adjusting for use with image bands, 5-10
- printer
  - cleaning, 3-3
  - communication problems, 4-7
  - communications, 2-16, A-3
  - components
    - back view, 1-4
    - front view, 1-4
  - connecting
    - AS400, 1-13
    - mainframe, 1-14
    - network, 1-12
    - PC, 1-11
  - cover
    - cleaning, 3-7
    - removing, 1-6
  - features, described, 1-3
  - inspection, 3-3
  - installation, 1-5
  - maintenance, 3-3
  - memory, using efficiently, 5-8
  - opening, 1-6
  - operation
    - testing, 6-5
    - troubleshooting, 4-3, 6-5

## EasyCoder 3400e Bar Code Label Printer User's Manual

- printer (*continued*)
  - options, A-6
    - coax interface, A-6
    - twinax interface, A-6
  - plugging in, 1-5
  - RAM
    - allocation, 5-8
    - storage limitations, 5-8
    - understanding, 5-8
  - serial port, C-11
- printhead
  - cleaning, 3-6
  - specifications, A-4
- printhead specifications, A-4
- printing
  - hardware configuration label, 1-9
  - increasing speed, 5-9
  - software configuration label, 2-13
  - speed, A-4
  - straight-through, 2-6
  - test label, 2-17
- printing speed specifications, A-4
- PrintSet, 2-16
- problems
  - communication, 4-7
  - print quality, 4-5
  - printer operation, 4-3
- protocols, C-3
  - Standard, C-3
  - user-defined, C-5
  - XON/XOFF, C-4, C-5
- Protocols
  - Multi-Drop, C-5
  - Polling Mode D, C-5

## R

- RAM, using efficiently, 5-8
- removing the printer cover, 1-6
- requirements
  - electrical, A-3
  - hardware and software, C-7
- resetting, memory, 6-6
- ribbon specifications, A-4
- RS-232 serial interface, C-7
- RS-422 serial interface, C-8
- RS-485 serial interface, C-8

## S

- safety summary, ix
- schedule of maintenance, 3-4
- self-strip printing
  - illustration of, 2-9
  - specifications, A-3
- serial port
  - cables, 1-11

- serial port (*continued*)
  - configuration, 1-15
  - description, C-11
  - settings, changing, 1-16
  - using to connect a PC to the 3400, 1-11
- setting
  - dot increments, number of, 6-9
  - Emulation mode, 6-11
  - media sensitivity number, 2-12
- software configuration label, printing, 2-13
- specifications, A-3
- speed, printing, A-4
- Standard protocol, C-3
- straight-through printing, 2-6
- sybologies
  - 2D, A-9
  - Codabar, A-8
  - Code 11, A-8
  - Code 128, A-8
  - Code 16K, A-9
  - Code 2 of 5, A-8
  - Code 39, A-8
  - Code 49, A-9
  - Code 93, A-8
  - Data Matrix, A-10
  - EAN, A-8
  - Interleaved 2 of 5, A-8
  - Maxicode, A-10
  - PDF417, A-9
  - POSTNET, A-8
  - UPC, A-9

## T

- tear bar, cleaning, 3-8
- technical support
  - contacting Intermec Technologies Corporation, ii
- terms and conventions, xii
- Test and Service mode
  - 86XX Emulation mode, 6-11
  - changing configuration commands from, 6-6
  - Data Line Print, 6-5
  - DIP switch settings, 6-4
  - entering, 6-3
  - exiting, 6-3
  - memory reset, 6-6
  - printing test labels, 6-5
  - using forms adjust, 6-12
  - X forms adjust, 6-13
  - Y forms adjust, 6-14
- test label
  - example of hardware configuration, 1-9
  - printing, 2-17, 6-5
- third-party software, 2-16
- throughput, increasing, 5-9

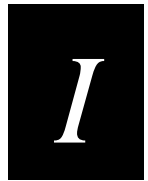

troubleshooting, 4-3  
  checklist, 4-3  
  communication problems, 4-7  
  print quality problems, 4-5  
  printer operation problems, 4-3  
twinax interface option, A-6

## ***U***

UPC, A-9  
uploading, definition, 2-16  
user-defined protocol, C-5

## ***W***

warnings and cautions, x  
warranty information, ix

## ***X***

X forms adjust  
  default origin, 6-13  
  setting dot increments, 6-7  
  setting with DIP switches, 6-13  
XON/XOFF  
  no status protocol, C-5  
  protocol, C-4

## ***Y***

Y forms adjust  
  default origin, 6-13  
  setting dot increments, 6-7  
  setting with DIP switches, 6-14



## Free Manuals Download Website

<http://myh66.com>

<http://usermanuals.us>

<http://www.somanuals.com>

<http://www.4manuals.cc>

<http://www.manual-lib.com>

<http://www.404manual.com>

<http://www.luxmanual.com>

<http://aubethermostatmanual.com>

Golf course search by state

<http://golfingnear.com>

Email search by domain

<http://emailbydomain.com>

Auto manuals search

<http://auto.somanuals.com>

TV manuals search

<http://tv.somanuals.com>