

IBM Network Color Printer:

Operator's Guide

Quick Start	
Task	Where to Look
Requesting service	page xiii
Ordering features and supplies	page 1-4
Choosing paper	page 2-2
Storing paper	page 2-5
Handling transparencies	page 2-6
Loading paper	page 3-2
Loading transparencies	page 3-9
Replacing a toner cartridge	page 5-4
Diagnosing problems	page 6-2
Clearing paper jams	page 6-3

NOTE

Before using this information and the product it supports, be sure to read the general information under "Notices" on page vii.

Second Edition (June 1996)

This edition applies to the *IBM Network Color Printer:Operator's Guide*.

This publication may contain references to, or information about, IBM products (machines or programs) or services that are not announced in your country. Such references or information must not be construed to mean that IBM intends to announce such IBM product, programming, or services in your country.

Information contained in this publication is subject to change from time to time. Changes will be reflected in future revisions.

You may send your comments by facsimile to 1-800-524-1519, by e-mail to print_pubs@vnet.ibm.com, or by mail to:

Department 582 Building 004M
IBM Printing Systems Company
Information Development
PO Box 1900
Boulder, CO, USA 80301-9817

IBM may use or distribute any of the information you supply in any way it believes suitable without incurring any obligation whatever. You may of course, continue to use the information you supply.

© Copyright International Business Machines Corporation 1996. All rights reserved.

Note to U.S. Government Users—Documentation related to restricted rights—Use, duplication, or disclosure is subject to restrictions set forth in GSA ADP Schedule Contract with IBM Corp.

Table of Contents

Table of Contents	iii
Notices	vii
Trademarks	vii
Communications Statements	viii
Preface	xi
Audience	xi
Organization and Contents of this Publication	xi
Terminology	xii
Safety Notices	xii
Safety Precautions	xii
Related Publications	xiii
Requesting Service	xiii
Chapter 1. Welcome to the IBM Network Color Printer	1-1
Introducing the Printer	1-2
General Description	1-2
Highlights	1-2
Optional Features	1-3
Ordering Supplies	1-4
Identifying Printer Parts and Controls	1-6
Front and Right Sides	1-6
Back and Left Sides	1-9
Inside the Front Door	1-10
Identifying Parts on the Density Control Panel	1-12
Turning the Printer On and Off	1-13
Turning the Printer On	1-13
Turning the Printer Off	1-13
Resetting the Printer	1-14

Chapter 2.	Choosing and Storing Paper and Transparencies	2-1
	Choosing Paper	2-2
	Paper You Should Use	2-2
	Paper You Should Not Use	2-2
	Understanding the Printable Area on a Page	2-4
	Handling and Storing Paper and Transparencies	2-5
	Handling and Storing Paper	2-5
	Handling and Storing Printouts	2-5
	Handling Transparencies	2-6
Chapter 3.	Loading Paper and Transparencies	3-1
	Loading Paper	3-2
	Loading Paper in Tray 1 and Tray 2	3-2
	Loading Paper in the Auxiliary Tray	3-6
	Choosing the Paper Output Tray	3-13
	Using the Side Output Tray	3-13
	Using the Top Output Tray	3-15
Chapter 4.	Using the Operator Panel	4-1
	Identifying Each Part of the Operator Panel	4-2
	Lights	4-2
	Online Push Button and Light	4-2
	Cancel Push Button	4-3
	Display Panel	4-3
	Control Push Buttons	4-3
	Paper Source Lights	4-4
	Canceling a Print Job	4-5
	Understanding the Menus	4-6
	Navigating the Menus	4-7
	Choosing a Menu Setting	4-7
	Using the Online Menu (Print Pages Menu)	4-8
	Printing the Help Map	4-9
	Printing a Job Log	4-9
	Printing a Configuration Page	4-9
	Printing a Test Page	4-10
	Printing the Color Pages	4-10
	Printing the Font Page	4-10
	Using the Offline Menus	4-11
	Entering a Password	4-13
	Deleting a Password	4-13
	Changing a Password	4-13
	Using the Printer Setup Menu	4-14
	Choosing the Paper Source	4-14
	Choosing the Paper Size	4-15
	Choosing the Color Mode	4-16
	Choosing to Print a Cover Page	4-16
	Choosing to Print When There Is a PostScript Error	4-17
	Choosing to Print a Start Page	4-18
	Using the System Setup Menu	4-19
	Setting the Printer Name	4-20
	Setting the Time and Date	4-20
	Changing the Password	4-21

	Setting the Power Savings Mode	4-23
	Using the Language Menu	4-24
	Changing the Language	4-24
	Language Menu Settings	4-24
Chapter 5.	Replacing Supplies	5-1
	Storing and Handling Toner Cartridges	5-2
	Ordering Supplies	5-3
	Replacing Toner Cartridges	5-4
	Removing the Old Cartridge	5-5
	Installing a New Cartridge	5-8
	Recycling the Used Toner Cartridge	5-13
	Replacing the Used Toner Bottle	5-14
	Replacing the Fuser Oil Bottle	5-16
	Removing the Old Fuser Oil Bottle	5-16
	Installing the New Fuser Oil Bottle	5-17
	Replacing the Fuser	5-19
	Preparing the Fuser and Work Area	5-19
	Unpacking the New Fuser	5-20
	Removing the Fuser Oil from the Printer	5-21
	Removing the Fuser Access Door	5-24
	Removing the Used Fuser	5-26
	Installing the New Fuser	5-27
	Replacing the Fuser Access Door	5-29
	Filling the New Fuser Unit with Fuser Oil	5-30
	Printing Test Pages	5-31
	Replacing the Photoconductor Drum Cartridge	5-33
	Locating the Orange Photoconductor Drum Shield	5-33
	Removing the Old Photoconductor Drum Cartridge	5-33
	Installing a New Photoconductor Drum Cartridge	5-35
	Recycling the Photoconductor Drum Cartridge	5-38
	Cleaning the Separation Corona Wire	5-39
Chapter 6.	Diagnosing Printer Problems	6-1
	Common Printer Problems	6-2
	Clearing Paper Jams	6-3
	Clearing a Paper Jam in Area 1 (Transfer Drum Area)	6-4
	Clearing a Paper Jam in Area 2 (Fuser Area)	6-6
	Clearing a Paper Jam in Area 3 (Paper Feeder Area)	6-9
	Clearing a Paper Jam in the Tray 2 Paper Feeder	6-12
	Correcting Print Quality Problems	6-13
	Adjusting the Side Registration on Tray 2 Printouts	6-20
	Adjusting the Color Density	6-22
	Printing Test Prints from the Density Control Panel	6-24
	Setting the Separation Corona Mode	6-26
Chapter 7.	Understanding Operator Messages	7-1
	Understanding POST Error Messages	7-2
	Function of POST Error Messages	7-2
	Table of POST Error Messages	7-2
	Understanding Operator Messages	7-5
	Understanding Warning Messages	7-5

Understanding Status Messages	7-7
Understanding Operator Error Messages.....	7-8
Chapter 8. Maintaining the Printer	8-1
Cleaning the Outside of the Printer	8-2
Cleaning the Paper Path	8-3
Cleaning the Paper Feeder Area	8-3
Cleaning the Transfer Drum	8-3
Cleaning the Separation Corona Wire	8-3
Cleaning the Window of the Density Detection Sensor	8-4
Cleaning the Fuser Rollers.....	8-5
Replacing the Air and Ozone Filters.....	8-6
Replacing the Separation Corona Unit.....	8-10
Replacing the Transfer Drum Cleaning Assembly	8-12
Appendix A. Help Map	Appendix A-1
Appendix B. Supplies Replacement Log	Appendix B-1
Appendix C. Wiring Diagrams.....	Appendix C-1
Acronyms and Abbreviations.....	X-1
Glossary	X-3
Index	X-15

Notices

References in this publication to IBM products, programs, or services do not imply that IBM intends to make these available in all countries in which IBM operates. Any reference to an IBM licensed product, program, or service is not intended to state or imply that only IBM's product, program, or service may be used. Any functionally equivalent product, program, or service that does not infringe any of IBM's intellectual property rights may be used instead of the IBM product. Evaluation and verification of operation in conjunction with other products, except those expressly designated by IBM, is the user's responsibility.

Any performance data contained in this publication was obtained in a controlled environment based on the use of specific data. The results that may be obtained in other operating environments may vary significantly. Users of this publication should verify the applicable data in their specific environment. Therefore, such data does not constitute a performance guarantee or warranty.

IBM may have patents or pending patent applications covering subject matter in this publication. The furnishing of this publication does not give you any license to these patents. You can send license inquiries, in writing, to the IBM Corporation, IBM Director of Licensing, 208 Harbor Drive, Stamford, Connecticut, United States, 06904.

Trademarks

The following terms are trademarks of the IBM Corporation in the United States or other countries or both:

AIX®
AIX/6000®
IBM®
OS/2®
Personal System/2®
PS/2®
RISC System/6000®
WIN-OS/2

The following terms are trademarks or registered trademarks of other companies:

Acrobat	Adobe Systems Inc.
Adobe	Adobe Systems Inc.
Adobe logo	Adobe Systems Inc.
Adobe Separator	Adobe Systems Inc.
Agfa®	Agfa Division, Miles Inc.

Apple®	Apple Computer Inc.
Apple logo	Apple Computer Inc.
AppleTalk®	Apple Computer Inc.
ATM (Adobe Type Manager)	Adobe Systems Inc.
AXIS®	AXIS Communication, Inc.
EPS (Encapsulated PostScript)	Altsys Corporation
Ethernet	Xerox Corporation
EtherTalk®	Aplice Computer, Inc.
Fiery	Electronics for Imaging Inc.
Fiery driven	Electronics for Imaging Inc.
Fiery XJ	Electronics for Imaging Inc.
Fiery logo	Electronics for Imaging Inc.
IPX (Internetwork Packet Exchange)	Novell Inc.
ITC Advant Garde Gothic®	International Typeface Corp.
ITC Bookman®	International Typeface Corp.
ITC Zapf Chancery®	International Typeface Corp.
ITC Zapf Dingbat®	International Typeface Corp.
Macintosh®	Apple Computer Inc.
Microsoft®	Microsoft Corp.
Mylar	E. I. du Pont de Nemours & Co., Inc.
Netware	Novell Inc.
Novell®	Novell Inc.
Pagemaker	Adobe Systems Inc.
PANTONE®	Pantone Co.
PostScript	Adobe Systems, Inc.
Quark XPress®	Quark Inc.
QuickDraw	Apple Computer Co.
TrueType	Apple Computer Co.
Univers®	Linotype AG and Subsidiaries
UNIX®	X/Open Company Limited
Windows	Microsoft Corp.

Communications Statements

Federal Communication Notices Commission (FCC) Statement

NOTE: This equipment has been tested and found to comply with the limits for a Class B digital device, pursuant to Part 15 of the FCC Rules. These limits are designed to provide reasonable protection against harmful interference in a residential installation. This equipment generates, uses, and can radiate radio frequency energy and, if not installed and used in accordance with the instructions, may cause harmful interference to radio communications. However, there is no guarantee that interference will not occur in a particular installation. If this equipment does cause harmful interference to radio or television reception, which can be determined by turning the equipment off and on, the user is encouraged to try to correct the interference by one or more of the following measures:

- Reorient or relocate the receiving antenna.

- Increase the separation between the equipment and receiver.
- Connect the equipment into an outlet on a circuit different from that to which the receiver is connected.
- Consult an IBM authorized dealer or service representative for help.

Properly shielded and grounded cables and connectors (IBM partnumber 68X3949 or its equivalent for PC parallel) must be used in order to meet FCC emission limits. Proper cables and connectors are available from IBM authorized dealers. IBM is not responsible for any radio or television interference caused by using other than recommended cables and connectors or by unauthorized changes or modifications to this equipment. Unauthorized changes or modifications could void the user's authority to operate the equipment.

This device complies with Part 15 of the FCC Rules. Operation is subject to the following two conditions: (1) this device may not cause harmful interference, and (2) this device must accept any interference received, including interference that may cause undesired operation.

European Union (EU) Electromagnetic Conformity Statement:

This product is in conformity with the protection requirements of EU Council Directive 89/336/EEC on the approximation of the laws of the Member States relating to electromagnetic compatibility. IBM cannot accept responsibility for any failure to satisfy the protection requirements resulting from a non-recommended modification of the product, including the fitting of non-IBM option cards.

EU Conformity Statement: This product has been tested and found to comply with the limits for Class B Information Technology Equipment according to CISPR 22/European standard EN 55022. The limits for Class B equipment were derived for typical environments to provide reasonable protection against interference with licensed communication devices.

German Conformity Statement: Dieses Gerät erfüllt die Bedingungen der EN 55022 Klasse B.

Industry Canada Compliance Statement: This Class B digital apparatus meets the requirements of the Canadian Interference-causing equipment regulations.

Cet appareil numérique de la classe B respecte toutes les exigences du Règlement sur le matériel brouiller du Canada.

Japanese VCCI Class 2 ITE Statement:

この装置は、第一種情報装置（商工業地域において使用されるべき情報装置）で商工業地域での電波障害防止を目的とした情報処理装置等電波障害自主規制協議会（VCCI）基準に適合しております。

従って、住宅地域またはその隣接した地域で使用すると、ラジオ、テレビジョン受信機等に受信障害を与えることがあります。

取扱説明書に従って正しい取り扱いをして下さい。

Preface

This publication tells you how to perform tasks such as loading paper, loading transparencies, removing paper jams, changing paper size, and other similar tasks.

Audience

This publication is intended for a key operator who maintains the printer and orders supplies, and for all users who replace supplies and who submit print jobs to this printer.

Organization and Contents of this Publication

This publication includes the following chapters:

- Chapter 1, “Welcome to the IBM Network Color Printer,” tells you about the printer’s features and parts. This chapter also lists supplies that you can order for the printer and tells you how to turn the printer on and off.
- Chapter 2, “Choosing and Storing Paper and Transparencies,” tells you what paper to use in the printer and how to store and handle paper and transparencies.
- Chapter 3, “Loading Paper and Transparencies,” tells you how to load paper into the printer, how to choose the tray for output, and how to know when to add paper.
- Chapter 4, “Using the Operator Panel,” tells you how the operator panel works and how to use menus on the display panel.
- Chapter 5, “Replacing Supplies,” tells you how to replace the printer’s toner cartridge, the used toner bottle, the fuser oil bottle, the fuser, and the photoconductor drum cartridge. It also tells you how to store and handle toner cartridges.
- Chapter 6, “Diagnosing Printer Problems,” helps you diagnose problems you may have when using the printer. It tells you how to clear paper jams and correct the quality of the printouts. This chapter also explains how to adjust the left margin of tray 2 and the color density of the printouts and how to set the separation corona mode.
- Chapter 7, “Understanding Operator Messages,” lists the messages that you may see on the display panel, tells you the reason for the message, and tells you what to do. Messages on the display panel tell you the printer’s status and alert you to upcoming problems. If the printer has an error during operation, you see an error message on the display panel.
- Chapter 8, “Maintaining the Printer,” tells you how to clean the printer and do routine maintenance tasks. Regular cleaning and maintenance (as needed) and careful handling of the printer keep the printer and print quality in the best condition.
- This publication includes a list of abbreviations, a glossary, and an index.

Terminology

Common Phrases

This guide refers to the IBM Network Color Printer as the printer. Additionally, the Network Print Server feature is referred to as the NPS.

Paper Input and Output Receptacles

Input receptacles are called trays, such as tray 1, tray 2, and auxiliary tray. Output receptacles are called output trays.

Safety Notices

There are 3 levels of safety notices:

- DANGER calls attention to a situation that is potentially extremely hazardous to people.
- CAUTION calls attention to a situation that is potentially hazardous to people.
- Attention calls attention to the possibility of damage to a program, device, system, or data. Attention notices are located throughout this publication, but are not listed here.
- Translations of the safety notices used in this library are found in *IBM Network Color Printer: Safety Information, G544-5352*. This publication is shipped with the printer and is provided with the maintenance documentation.

Safety Precautions

Electrical Safety

This printer is inspected and listed by recognized national testing laboratories, such as Underwriters Laboratories, Inc. (UL) in the U.S.A. and Canadian Standards Association (CSA) in Canada. Listing of a product by a national testing laboratory indicates that the product is designed and manufactured in accordance with national requirements intended to minimize safety hazards. IBM equipment meets a very high standard of safety in design and manufacture. Remember, however, that this product operates under conditions of high electrical potentials and heat generation, both of which are functionally necessary.

Because the paper and toner used in the printer can burn, you should take normal precautions to prevent fire. These precautions include common-sense measures, such as keeping potentially combustible materials (for example, curtains and chemicals) away from the printer, providing adequate ventilation and cooling, limiting unattended operation, and having trained personnel available and assigned to the printer.

Laser Safety

This printer complies with the performance standards set the by U.S. Food and Drug Administration for a Class 1 Laser Product. This means that the printer belongs to a class of laser products that does not produce hazardous laser radiation in a customer access area. This classification was accomplished by providing the necessary protective housing and scanning safeguards to ensure that laser radiation is inaccessible or within Class 1 limits.

There are various tool-operated machine covers that should be moved, removed, or replaced only by trained service personnel. There are no operator controls or adjustments associated with the laser.

No operator maintenance is required to keep the product in compliance as a Class 1 Laser Product. No adjustments that affect laser operation or power are accessible to the operator.

Note: See *IBM Network Color Printer: Safety Information* for national language translations regarding laser safety.

Disposal of Materials

This printer may contain materials, either as components or supplies, that are regulated by government agencies for disposal. Dispose of all such items in accordance with your governmental agencies regulations.

Related Publications

The following publications are included in hardcopy with this printer:

- *IBM Network Color Printer: Administrator's Guide*, S544-5364
- *IBM Network Color Printer: Operator's Guide*, S544-5361
- *IBM Network Color Printer: Quick Print Guide*, softcopy only
- *IBM Network Color Printer: Installation and Relocation Guide*, G544-5362
- *IBM Network Color Printer: Safety Information*, G544-5352
- *IBM Network Color Printer: User's Guide*, S544-5363

The above publications are also available in Adobe Acrobat Reader format on the *IBM Network Color Printer:Customer CD-ROM* shipped with this printer. You can view these publications using Adobe Acrobat Reader, which is included on the CD-ROM. The *User's Guide* contains instructions for installing Adobe Acrobat Reader and the softcopy documentation onto your system.

If you wish to purchase additional copies of the publications, please contact your IBM service representative or authorized service dealer.

Requesting Service

To request service on your IBM Network Color Printer in the U.S. or Canada, call **1-800-358-6661**. Service is available from 9 a.m. to 9 p.m. EST. To request service in other countries, call your country Call Center.

- You may call for service free of charge during the printer's warranty period.
- You can obtain service after the warranty period has expired if you sign a service contract agreement with an authorized service provider.
- You also can obtain service on a billable-per-call basis after the warranty period has expired.
- Please have your service contract information available when you call.

Chapter 1. Welcome to the IBM Network Color Printer

This chapter tells you about the printer's features and parts. This chapter also lists supplies that you can order for the printer and tells you how to turn the printer on and off.

This chapter covers the following topics:

Introducing the Printer	1-2
General Description	1-2
Highlights	1-2
Optional Features	1-3
Ordering Supplies	1-4
Identifying Printer Parts and Controls	1-6
Front and Right Sides	1-6
Back and Left Sides	1-9
Inside the Front Door	1-10
Identifying Parts on the Density Control Panel	1-12
Identifying Parts on the Density Control Panel	1-12
Turning the Printer On and Off	1-13
Turning the Printer On	1-13
Turning the Printer Off	1-13
Resetting the Printer	1-14

Introducing the Printer

This section gives you a general overview of the printer, including highlights and optional features.

General Description

The IBM Network Color Printer is a midrange workgroup printer. It can produce single-sided black and white prints at a rate of up to 12 impressions per minute (IPM) and full-color prints at a rate of up to 3 IPM. The printer has a cyan-magenta-yellow-black (CMYK), full-color laser processor that prints 16 gray levels per color. The printer prints PostScript jobs in Windows, Macintosh, and UNIX environments.

Highlights

Some of the highlights of the printer are:

- **Toner cartridges**

The printer uses 4 separate color toner cartridges (cyan, magenta, yellow, and black). When a toner cartridge is used up, you can replace it with a new one of the same color.

- **Flexible color range**

The 4 color toner cartridges offer output in full color, a single color only (monocolor), or true black (using the black toner cartridge).

- **High resolution**

The printer has a print resolution of 600 × 600 dots per inch, which results in laser-sharp output in full color.

- **High print speed**

The printer delivers up to 3 pages per minute in full color or up to 12 pages per minute in monochrome (black only).

- **Flexible paper handling**

The universal paper cassette in tray 1 accepts letter, legal, A4, and JIS B5 paper sizes. It can hold approximately 250 sheets (at 80 g/m²) of plain paper. The auxiliary tray accepts transparencies as well as plain paper. To increase the volume of paper, you can add an optional tray 2 paper feeder.

Note: This printer does only simplex (single-side) printing. Duplex printing is not available.

Optional Features

The printer has several optional features. See the following sections for more on these features. Contact your IBM marketing representative or authorized service dealer for information about the following optional features and how to order them.

Optional Tray 2 Paper Feeder (Feature Code 4501)

This feature includes a paper feeder unit, a universal paper cassette, and 2 locking pins to fasten the paper feeder unit to the printer body. The universal paper cassette accepts letter, legal, A4, and JIS B5 paper sizes. It can hold approximately 250 sheets (at 80 g/m²) of plain paper.

Universal Paper Cassette (Feature Code 4513)

You can buy an additional universal paper cassette that holds letter, legal, A4, and JIS B5 paper. You can load only plain paper from 64 to 90 g/m² into a paper cassette, and the maximum capacity is approximately 250 sheets at 80 g/m².

Printer Stand (Feature Code 3050)

The printer stand is designed to hold the weight of the printer. It has a storage area underneath for supplies, locking casters for easy movement, and leveling feet for uneven floor surfaces.

Memory Upgrades

The standard printer configuration includes 16MB of memory. Any printer can be upgraded to 32MB or 48MB (maximum).

- Feature Code 4316 consists of four 4MB SIMMs.
- Feature Code 4332 consists of four 8MB SIMMs.



For further information about installing the memory upgrades, see the *Installation and Relocation Guide*.

Ordering Supplies

This section lists the supplies you can order for the printer and gives you the telephone number you should use when ordering supplies.

To order supplies for the printer, call 1-888-IBM-PRINT in the U.S. and Canada. You may also contact your IBM marketing representative for information about how to order supplies.

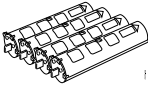
The following table lists the supplies you can order for the printer.

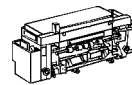
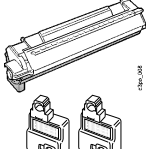
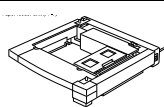
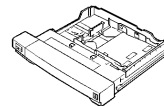
Supplies			
	Item	Part Number	Description
	Magenta Toner Cartridge	63H2041	IBM recommends that you use only IBM color toner cartridges designed for this printer. You need 4 color toner cartridges: cyan, magenta, yellow, and black. You get 1 cartridge in each box.
	Black Toner Cartridge	63H2050	
	Cyan Toner Cartridge	63H2051	Each color toner cartridge typically lasts approximately 4,000 prints of A4- or letter-size paper (when printing at 4% to 5% toner coverage). The actual cartridge life, however, depends on how much toner you use for each print. The more toner of 1 color that you use, the shorter that cartridge's life becomes. For details, see "Replacing Toner Cartridges" on page 5-4.
	Yellow Toner Cartridge	63H2052	
	Fuser Oil Bottle in Single Box	63H2043	Fuser oil is used in the fusing process. Fuser oil keeps the toner on the paper and prevents it from getting on the fuser rollers. You can order fuser oil 1 bottle at a time or in 20-bottle packages.
	20 Unit Boxed Fuser Oil Bottles	63H2044	
	Fuser—110 V	63H3776	The fuser uses pressure and heat to bond the toner to the paper.
	Fuser—220 V	63H3779	
	Photoconductor Drum Cartridge Kit	63H2042	The photoconductor drum cartridge kit contains the following items: a photoconductor drum cartridge, an orange protective shield, and 2 used toner bottles. When you replace the photoconductor drum cartridge, always replace the used toner bottle as well. This bottle collects the excess toner during printing.
	Optional Paper Feeder	63H2004	The optional paper feeder comes with a universal cassette and 2 locking pins to fasten it to the printer body.
	Universal Cassette	63H2006	The universal cassette holds letter-, legal-, A4-, and JIS B5-size paper. You can load only plain paper from 64 to 90 g/m ² into a paper cassette, and the maximum capacity is approximately 250 sheets at 80 g/m ² .

Supplies

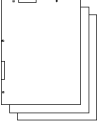
Item		Part Number	Description
	Transparencies— 50-Sheet Letter Pack	63H2046	IBM recommends that you use only IBM transparencies for the best printing results.
	Transparencies— Ten 50-Sheet Letter Packs	63H2047	
	Transparencies— 50-Sheet A4 Pack	63H2048	
	Transparencies— Ten 50-Sheet A4 Packs	63H2049	
Relocation Kit		52H0799	The relocation kit contains the packaging, boxing, and instructions that you need to safely move the printer a substantial distance.
60 000-Page Usage Kit (for low voltage 110 V)		63H1980	The 60 000-page usage kit is installed by the operator and is needed after approximately 60 000 pages have been printed. It contains the following items: air filter, ozone filter, transfer drum cleaning assembly, separation corona unit, and fuser.
60 000-Page Usage Kit (for high voltage 220 V)		63H1981	

Identifying Printer Parts and Controls

This section helps you identify each part of the printer. The illustrations that follow show the printer's parts and controls and what they are used for.

Front and Right Sides

Shown below are the parts of the printer that you access from the front and right sides.

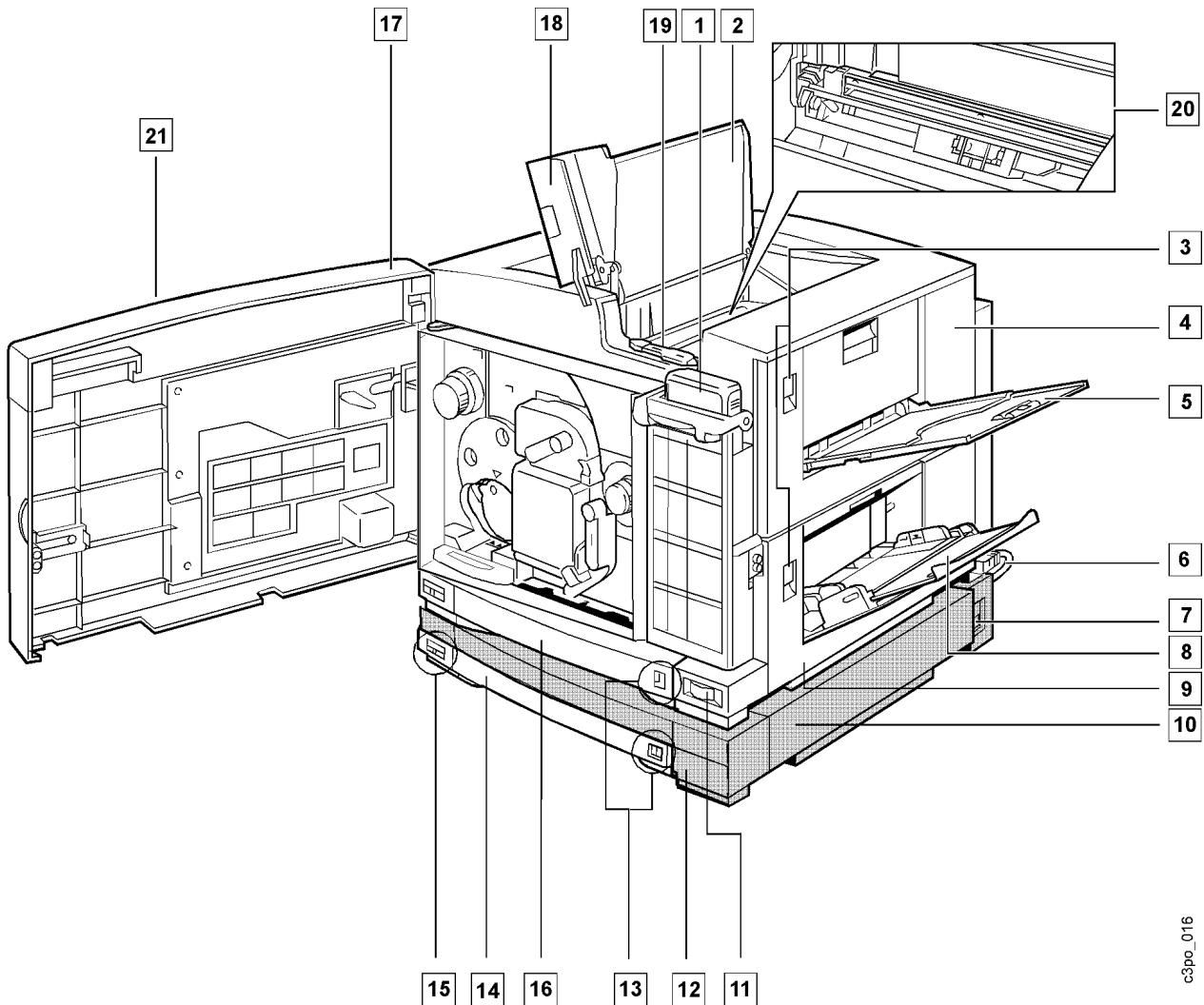

- 1 Fuser oil bottle (cover open)**
The fuser oil bottle supplies the fuser oil that is applied to the fuser rollers during the printing process.
- 2 Top cover (open)**
When opened, the top cover gives you access to the transfer drum area so that you can remove jammed paper or replace the separation corona unit.

- 3 Release latches**
The release latches release the catches on the fuser access and feeder access doors so that you can do maintenance tasks or clear paper jams.
- 4 Fuser access door (closed)**
When opened, this door gives you access to the paper output area so that you can remove jammed paper and replace the fuser.
- 5 Side output tray (faceup) (open)**
When opened, the side output tray receives printouts faceup. When the side output tray is closed, the top output tray receives printouts facedown. The side output tray holds approximately 20 sheets of plain paper at 80 g/m².
- 6 Route power cable (on optional paper feeder unit) (shown installed)**
This cable connects the power outlet on the optional paper feeder unit with the power receptacle on the printer body.
- 7 Power receptacle (on paper feeder unit)**
The printer power cord plugs in here and then connects to a power source (100–120 V ac or 220–240 V ac depending on the voltage model of the printer package).
- 8 Auxiliary tray (open)**
This tray holds approximately 100 sheets of plain paper at 80 g/m² or 20 transparencies.
- 9 Feeder access door**
Opening this door gives you access to the paper feeder area so that you can remove jammed paper, do maintenance tasks, or replace the transfer drum cleaning unit.
- 10 Feeder access door (on tray 2 paper feeder) (closed)**
Opening this door gives you access to the tray 2 paper feeder area so that you can remove jammed paper.
- 11 Power switch**
- 12 Optional tray 2 paper feeder**
This paper feeder holds a universal paper cassette.
- 13 Paper amount indicator**
This shows the paper level. When the blue bar has completely disappeared, it is time to add paper to the tray.
- 14 Tray 2 universal paper cassette (optional)**
This cassette holds approximately 250 sheets of letter-, legal-, A4-, or JIS B5-size paper at 80 g/m².
- 15 Paper size indicator**
This shows you the paper size loaded in the paper cassette.
- 16 Tray 1 universal paper cassette**
This tray holds approximately 250 sheets of letter-, legal-, A4-, or JIS B5-size paper at 80 g/m².
- 17 Front door (open)**
When opened, this door gives you access to the inside of the printer so that you can replace supplies, clear paper jams, and do maintenance tasks.

18 Top output tray (facedown) (open)

This tray holds approximately 100 sheets of plain paper at 80 g/m².

19 Wire cleaner (stored inside the printer)

The wire cleaner is used to clean the separation corona wire (inside the separation corona unit) and the window of the density detection sensor. The wire cleaner looks like this:

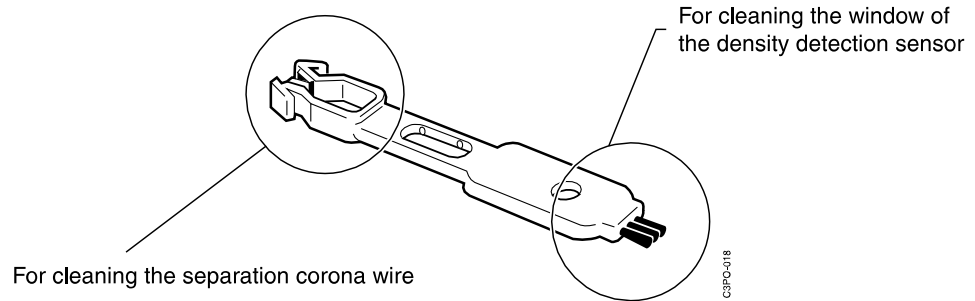

20 Separation corona unit

The separation corona unit helps separate the printout from the photoconductor drum cartridge during the printing process. The wire is cleaned with the wire cleaner that is stored inside the printer.

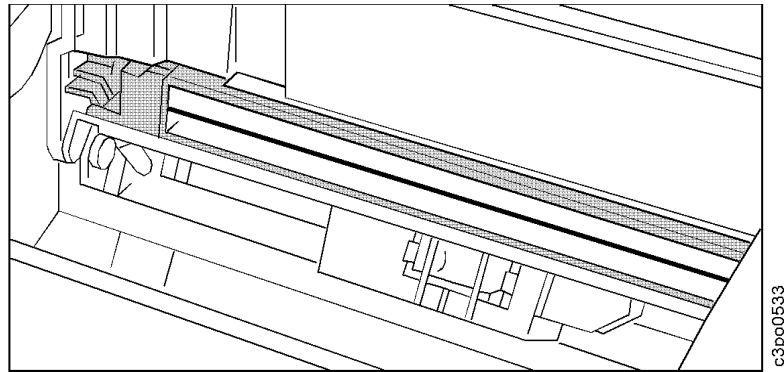

21 Operator panel

The operator panel is on the outside of the printer's front door. It has lights and push buttons that are used to control the printer and to indicate the printer's status.

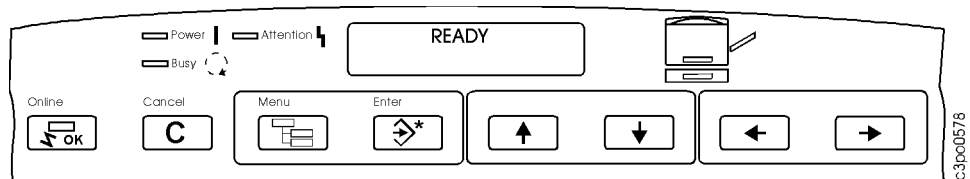

Back and Left Sides

Shown below are the parts of the printer that you access from the back and left sides of the printer.

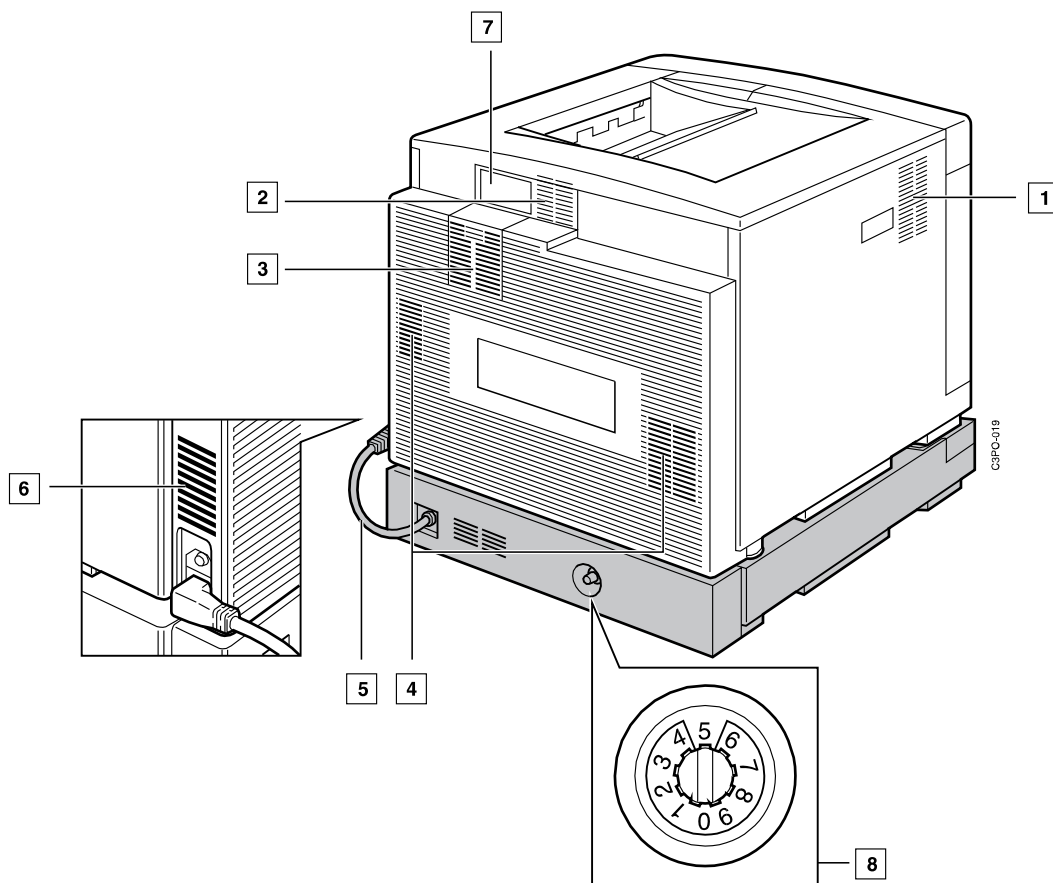

1 2 3 4 and 6 Air ventilation slots

These slots prevent overheating and ensure that the printer works reliably. Do not block these air ventilation slots.

3 Air filter holder

This holder contains the air filter and gives you access to the carbon filter.

5 Route power cable (on optional paper feeder unit)

This cable connects the power outlet on the optional paper feeder unit with the power receptacle on the printer body.

7 Density control panel

This panel adjusts the color density (see “Identifying Parts on the Density Control Panel” on page 1–12).

8 Side registration adjustment dial

This dial adjusts the left margin width of the tray 2 paper feeder.

Inside the Front Door

Shown below are the parts of the printer that are inside the front door of the printer.

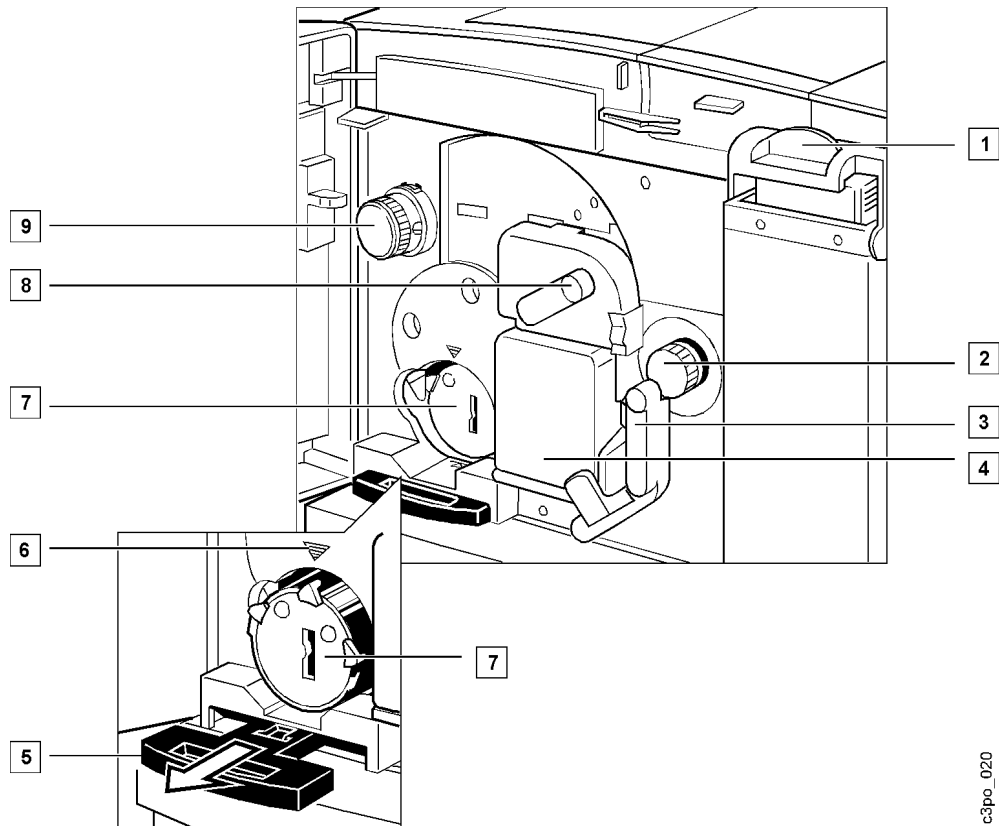

- 1 Fuser oil bottle cover (closed)**
When closed, this cover locks the fuser oil bottle securely to the printer.
- 2 Transfer drum knob**
When turned, this knob rotates the transfer drum so that you can remove jammed paper (the release handle must be down).
- 3 Release handle**
This handle unlocks the used toner bottle, the photoconductor drum cartridge, and the transfer drum so that you can clear paper jams or do maintenance tasks.
- 4 Used toner bottle**
This bottle receives excess toner not fused during the print cycle.
- 5 Eject handle**
When pulled, this handle ejects a toner cartridge so that you can replace it.
- 6 Toner cartridge position mark**
This mark helps you align a toner cartridge. When you insert a toner cartridge, you align the arrow on the toner cartridge label with the position mark.
- 7 Toner cartridges in turret**
Each toner cartridge contains a color of toner (cyan, magenta, yellow, or black) that is applied to the printout.

8 Photoconductor drum cartridge door handle

When raised, this handle opens the photoconductor drum cartridge door so that you can install or replace a photoconductor drum cartridge.

9 Turret rotation knob

When pushed and turned, this knob rotates the turret so that you can replace the toner cartridge.

10 Serial number label (see below)

The serial number label identifies the printer. You see the serial number label when you open the feeder access door. Do not remove this label.

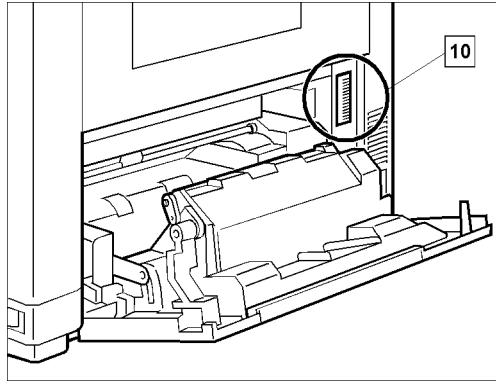

Serial Number Label

c3pc_021

Identifying Parts on the Density Control Panel

This section helps you identify each part of the density control panel.

You rarely will need to use the density control panel. See “Adjusting the Color Density” on page 6–22 for some task-specific information.

The density control panel is on the back of the printer. Shown below are the parts of the density control panel.

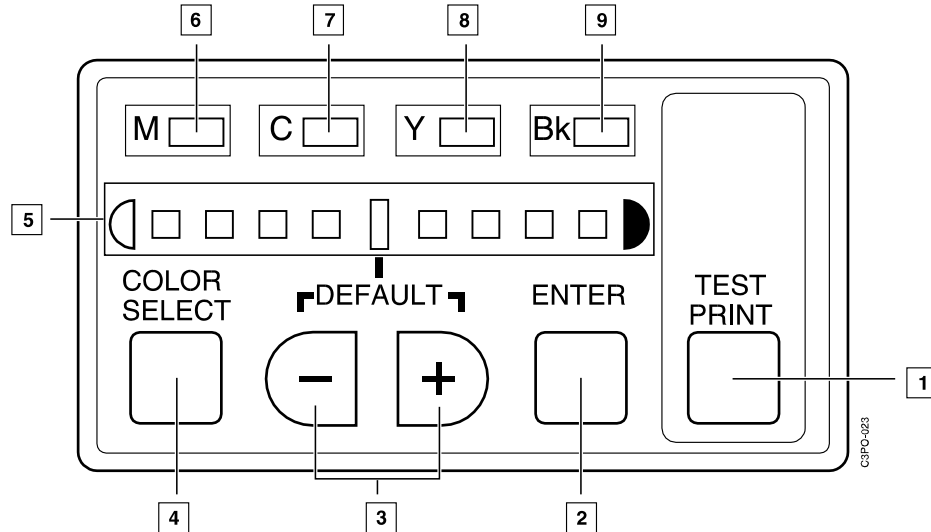

- 1 TEST PRINT push button**
Press the **TEST PRINT** push button to print a test pattern that can be used to check the result of a density change.
- 2 ENTER push button**
Press the **ENTER** push button to accept the density value that is currently defined.
- 3 +/- push buttons**
Press these push buttons to choose a density setting or a test pattern.
- 4 COLOR SELECT push button**
Press the **COLOR SELECT** push button to choose a color for density change.
- 5 Density gauge**
The density gauge shows you the density of the test pattern's color. (The light that is lit shows you the current level.) The default density is indicated on the gauge.
- 6 through 9 Color Lights (M, C, Y, Bk)**
Each light turns green when you choose the color next to it for density change.

Turning the Printer On and Off

This section tells you how to turn the printer on and off. When you turn the printer and its connected devices on or off, follow the procedure below.

Attention:

Never turn the printer on without a fuser oil bottle and a used toner bottle installed.

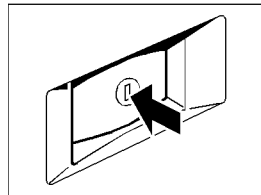

ON

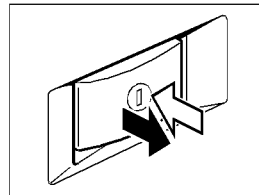

OFF

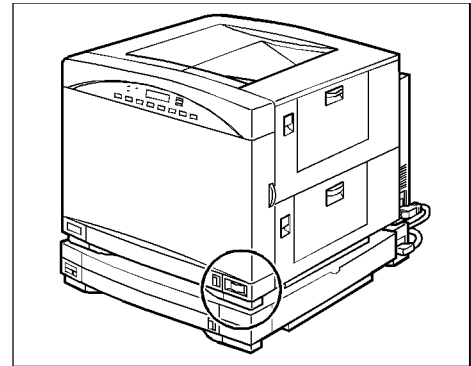

c3po0562

Turning the Printer On

Use the following procedure to turn on power to the printer.

1. Turn on any devices connected to the printer (such as a SCSI hard drive or CD ROM).
2. Press the power switch to turn on the printer (the switch remains pressed).
3. Turn on the host computer.

Note: If you see an error message after you turn on the printer, see "Understanding POST Error Messages" on page 7-2 to learn what to do.

Turning the Printer Off

Attention:

Never turn off the printer while it is printing. If power to the printer is accidentally lost, open the paper jam clearance areas (see "Clearing Paper Jams" on page 6-3) and remove any paper left inside before turning on the printer again.

Use the following procedure to turn off power to the printer.

1. Turn off the host computer.
2. Turn off any devices connected to the printer (such as a SCSI hard drive or CD ROM).
3. Press the power switch to turn off the printer (the switch is released).

Resetting the Printer

Use the following procedure to reset the printer.

1. Turn off the printer.
2. Wait 5 seconds or more before you turn the printer on again.
3. Turn on the printer.

Chapter 2. Choosing and Storing Paper and Transparencies

This chapter tells you what paper to use in the printer and how to store and handle paper and transparencies.

This chapter covers the following topics:

Choosing Paper	2-2
Paper You Should Use	2-2
Paper You Should Not Use	2-2
Understanding the Printable Area on a Page	2-4
Handling and Storing Paper and Transparencies	2-5
Handling and Storing Paper	2-5
Handling and Storing Printouts	2-5
Handling Transparencies	2-6

Choosing Paper

This section gives you the specifications for paper you *should* use and paper you *should not* use in the printer. Using a good quality of paper ensures the best print quality, prevents paper jams, and reduces the amount of maintenance needed.

Note: Not all print media can be used in this printer. Always print a few pages before you buy a large quantity of paper. IBM recommends that you use IBM paper for the best printing results. Envelopes and labels are not recommended.

Paper You Should Use

The following table gives you specifications for paper you should use in the printer.

Paper Specifications				
Source	Paper	Size	Weight	Capacity
Tray 1 or tray 2	Plain	216 × 356 mm to 184 × 267 mm Letter (8.5 × 11 inches) Legal (8.5 × 14 inches) A4 (210 × 297 mm) JIS B5 (182 × 257 mm)	60 to 90 g/m ²	Up to a 25-mm stack height (approximately 250 sheets of 80 g/m ² paper)
Auxiliary tray	Plain	216 × 356 mm to 184 × 267 mm Letter (8.5 × 11 inches) Legal (8.5 × 14 inches) A4 (210 × 297 mm) JIS B5 (182 × 257 mm)	60 to 105 g/m ²	Up to a 10-mm stack height (approximately 100 sheets of 80 g/m ² paper)
	Transparencies	Letter (8.5 × 11 inches) A4 (210 × 297 mm)		Approximately 20 sheets

Paper You Should Not Use

This section lists the kinds of paper that you should not use in the printer.

Do not use paper that easily causes paper jams. Examples are:

- Labels
- Envelopes
- Paper that is too thick or too thin
- Wet paper
- Highly textured or rough paper
- Curled, creased, or damaged paper
- Nonrectangular paper such as aerograms
- Paper with cutouts or perforations such as 3-hole-punched paper
- Paper with an irregular shape
- Paper with wrinkles or rips
- Paper with special coating

During the fusing process, paper is exposed to high temperatures. Do not use paper that is affected by high temperatures. Examples are:

- Thermal paper
- Paper whose surface cannot hold the toner at high temperature
- Preprinted paper containing ink that deteriorates at high temperatures (for example, invoices and preprinted forms)
- Adhesive paper

Attention:

Paper that changes or deteriorates at high temperatures can damage this printer. Check preprinted paper and coated paper to make sure that it meets the heat-compatibility specifications before printing on it.

Do not use paper that could damage the printer. Examples are:

- Carbon paper
- Paper with staples, ribbons, tape, or other material stuck to it
- Paper on which one side is already printed

Understanding the Printable Area on a Page

This section shows you the area of a page on which you can print.

The shaded part of the figure below shows you the printable area on a sheet of paper or transparency. The table that follows the figure gives you the measurements for the border width of different sizes of paper.

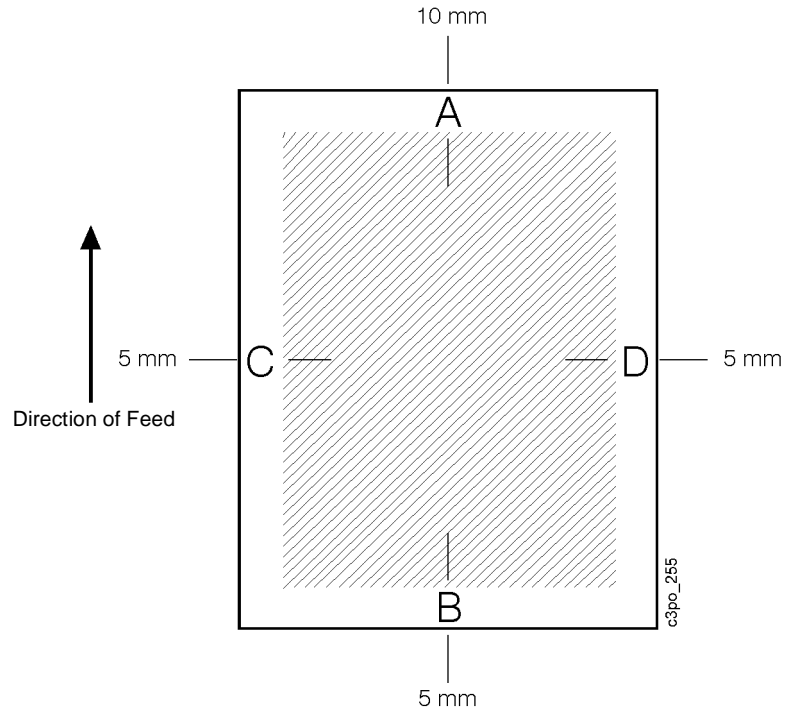

Size	Border Width			
	A	B	C	D
Letter, legal, A4, and JIS B5 (mm)	10.0	5.0	5.0	5.0
Letter, legal, A4, and JIS B5 (inches)	0.4	0.2	0.2	0.2

Handling and Storing Paper and Transparencies

This section tells you how to handle paper, store it, store printouts, and handle transparencies for the best print quality.

Handling and Storing Paper

Paper that you handle and store correctly is in the best shape for printing. Follow these guidelines for handling and storing paper.

- Store unused paper in its wrapping to protect the paper against humidity.
- Do not store the paper directly on the floor. The floor is usually humid.
- If the storage place is humid, use a specially designed storage box for the paper.
- Store paper on a flat surface to prevent it from curling.
- Do not stack the paper too high. Doing so may make it curl.
- Do not expose the paper to direct sunlight or a humid environment.
- If you move the paper to a place with a different temperature, leave the paper there for 24 hours before using it. Otherwise, the paper may curl or wrinkle.
- Make sure that the paper meets the printer's specifications (see "Choosing Paper" on page 2–2) and that it has been in the printer environment for at least 24 hours before you use it. This is especially important if you are in a climate with high humidity.

Handling and Storing Printouts

Follow these guidelines for handling and storing color printouts.

- The color on a printout hardly fades under normal room light. But if you plan to keep the color printouts for more than 2 years, put them in a binder. (Sometimes the color appears to change when, in fact, it is a color change in the paper itself.)
- Do not store color printouts together with polyvinyl chloride (PVC) materials, such as clear holders. The toner may melt, causing the paper and the PVC materials to stick together.
- Use only nonsolvent glues to glue color printouts together.
- Solvents in glue may dissolve the toner. Before using a glue, test it on unwanted printouts.
- Before inserting any color printout between printouts, make sure the pages are completely dry. If they are not dry, the ink may cause the toner to melt.
- Store color printouts flat. If they are folded or wrinkled, the toner may come off.
- Store color printouts at normal temperature. High temperature causes the toner to melt and the colors to mix.

Handling Transparencies

IBM recommends that you use IBM transparencies for the best printing quality. Follow these guidelines for handling transparencies:

- Use IBM color transparencies only with IBM color printers. These transparencies are designed exclusively for color laser printers.
- Pick up each printed transparency as soon as it comes out of the printer to prevent the next sheet from jamming.
- Make sure no fuser oil gets on a transparency. Printing on a transparency that has fuser oil on it may result in poor print quality.
- When you tap the transparencies to avoid multiple feeds, be careful not to scratch the films or leave fingerprints on the print sides. (If you look at a transparency with its white marker positioned on the upper right side, the side facing away from you is the print side.)
- This printer accepts short-edge feed (SEF) feed only.
- Avoid high temperatures and high humidity. Be sure to store any remaining transparencies in their protective bags.

Chapter 3. Loading Paper and Transparencies

This chapter tells you how to load paper into the printer, how to choose the tray for output, and how to know when to add paper.

This chapter covers the following topics:

Loading Paper	3-2
Loading Paper in Tray 1 and Tray 2.....	3-2
Loading Paper in the Auxiliary Tray	3-6
Choosing the Paper Output Tray	3-13
Using the Side Output Tray	3-13
Using the Top Output Tray	3-15

Loading Paper

This section tells you how to load paper in tray 1, tray 2, and the auxiliary tray. Follow these guidelines when you load paper:

- Make sure that the paper meets the printer's specifications (see "Choosing Paper" on page 2–2) and that it has been in the printer environment for at least 24 hours before you use it. (This is especially important if you are in a climate with high humidity.)
- Do not load transparencies in tray 1 or tray 2. Use the auxiliary tray instead.

Loading Paper in Tray 1 and Tray 2

Tray 1 and tray 2 can each hold approximately 250 sheets of plain paper (at 80 g/m²). Paper sizes you can use are letter, legal, A4, and JIS B5.

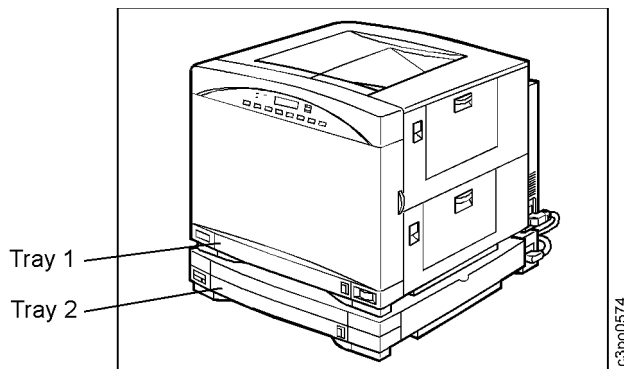

Tray 1 and tray 2 each have a paper amount indicator that shows you how much paper remains. The blue bar on the paper amount indicator gradually goes out of view as paper runs out. When the blue bar has completely disappeared, it is time to refill the tray.

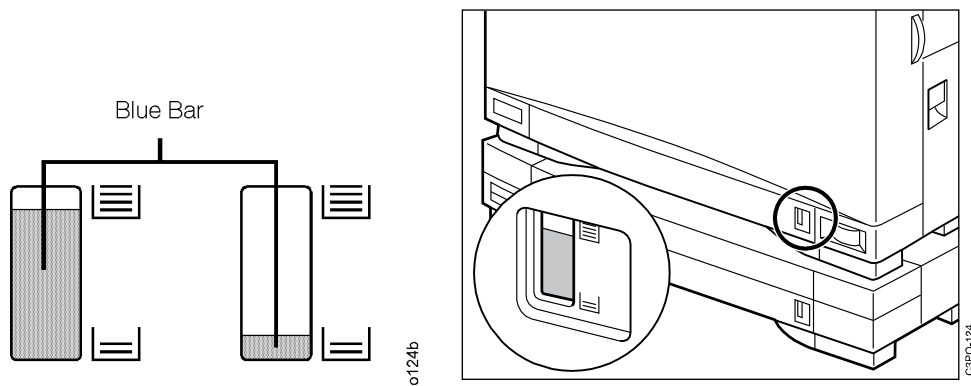

Use the following procedure to load paper into either tray 1 or tray 2.

1. Push up the handle on the underside of the tray and pull out the tray (tray 1 is shown here).

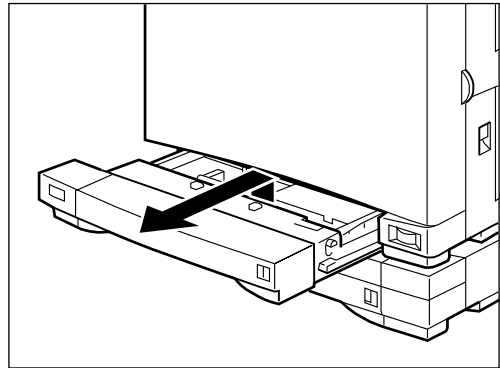

2. Press the release button and slide the paper-width guide to the size of paper to be loaded. Release the button to lock the guide in place. Where you set the paper-width guide determines how the printer knows what size of paper is in the tray. Make sure that the paper-width-guide setting matches the size of paper to be loaded.

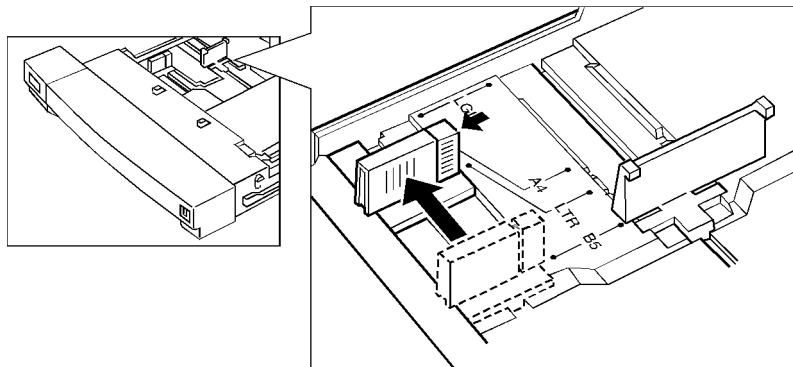

Note: If there is paper in the tray already, you must remove it before adjusting the paper-width guide.

3. Lift the paper-length guide slightly and slide it to select the paper length that you want. Release the guide to lock it in place.

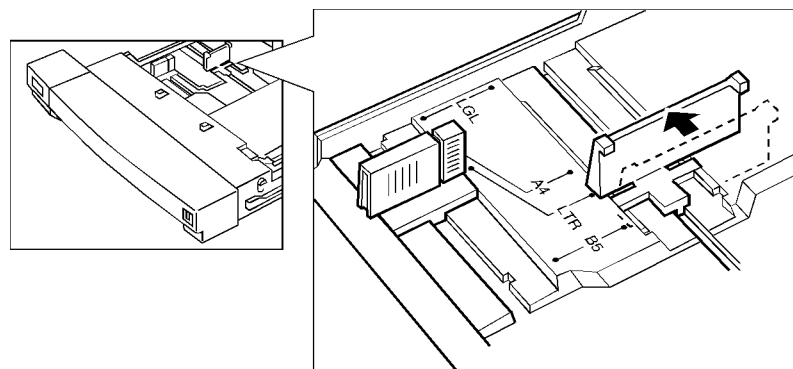

4. Set the paper-size indicator on the front of the tray to match the paper size you loaded (for example, LTR for letter-size paper). This helps you and others identify the size of paper in the tray.

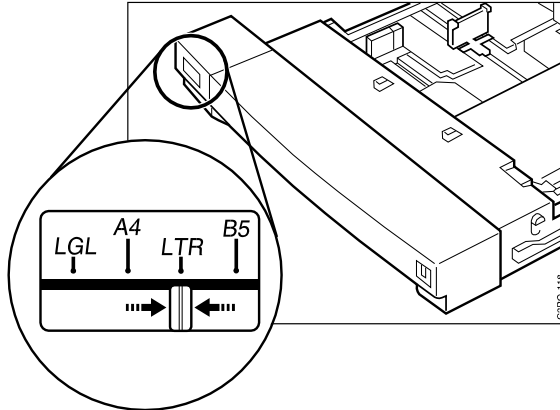

5. Load the paper.
 - a. Fan out small stacks of paper to lessen the chance of feeding problems.

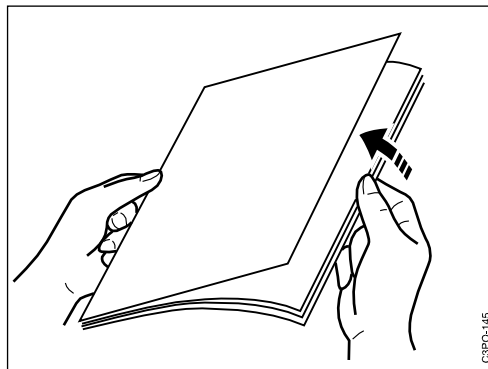

- b. Put the tray on a flat surface. Then load a stack of paper into the tray with the print side facing up and the bottom edge going first into the tray.

Note: For the best print quality, put the print side (as marked on the paper wrapper) face up.

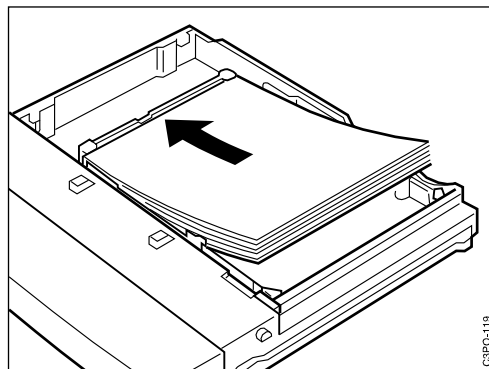

c. Make sure the paper stack does not go above the paper-limit mark.

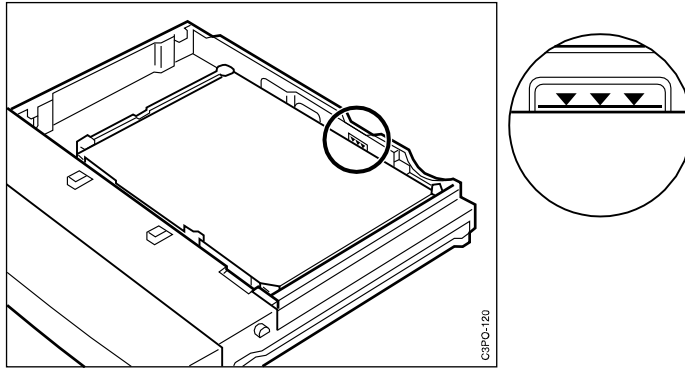

6. Press down on the paper so that it is anchored under the 2 retaining clips.

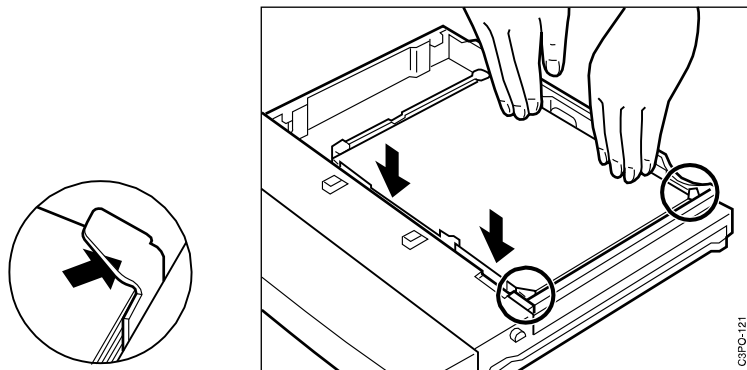

7. Align the tray so that it lines up with the rails inside the paper feeder.

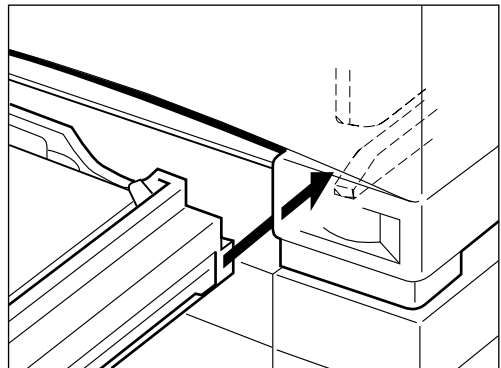

8. Press the handle on the underside of the tray upward and slide the tray all the way into the paper feeder until the tray snaps into place.

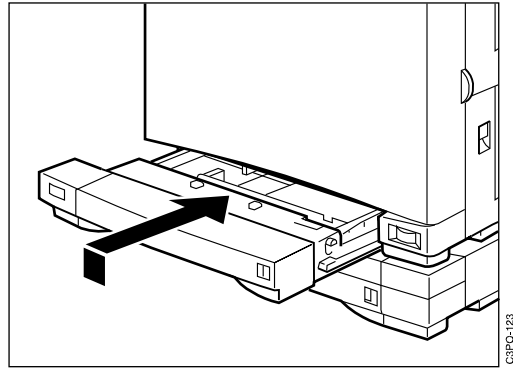

The tray is now ready to supply paper.

Loading Paper in the Auxiliary Tray

The auxiliary tray holds approximately 100 sheets of paper at 80 g/m². You can use letter, legal, A4, or JIS B5-size paper and letter- and A4-size transparencies. You can close the tray when it is not in use, making the printer very compact.

Opening the Auxiliary Tray

Use the following procedure to open the auxiliary tray.

1. Pull on the latch to open the auxiliary tray.

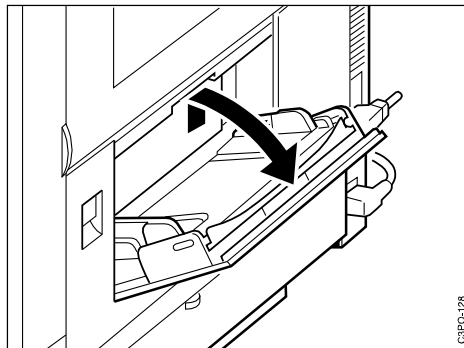

2. Pull out the extension tray and then gently press down to lock it.

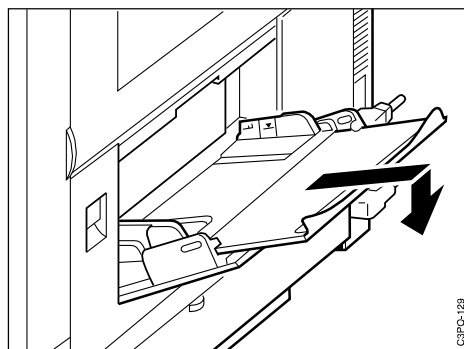

Loading Paper in the Auxiliary Tray

Note: Make sure that the paper meets the printer's specifications (see "Choosing Paper" on page 2-2) and that it has been in the printer environment for at least 24 hours before you use it. (This is especially important if you are in a climate with high humidity.)

Use the following procedure to load paper in the auxiliary tray.

1. Adjust the paper guides to the paper size you want.

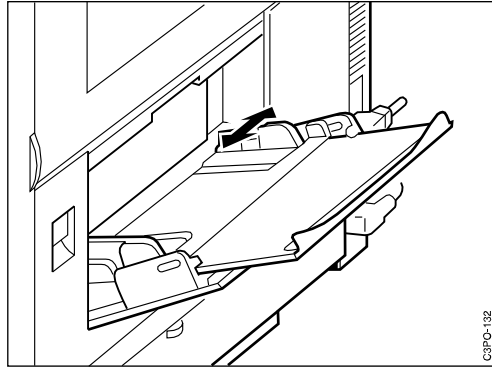

2. Tap a stack of paper on a flat surface to align its edges.

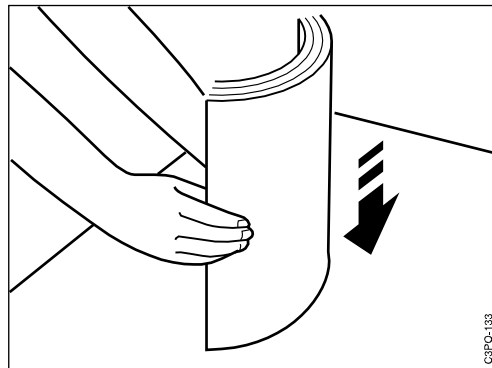

3. Insert the paper stack as far as it can go into the printer. Make sure that the print side faces down and the top of the page goes into the printer first.

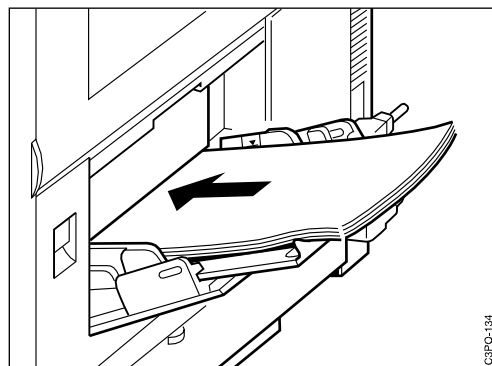

4. Check that the paper stack does not go above the paper-limit mark.

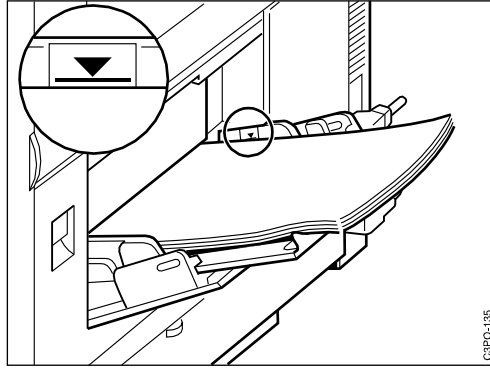

Avoid pressing or applying excessive force to the auxiliary tray.

The auxiliary tray is now ready to supply paper.

Follow these guidelines for loading paper.

1. Load the auxiliary tray with only one size of paper at a time.
2. Add paper to the auxiliary tray only when it is completely empty. Otherwise, you may cause the paper to feed incorrectly or to jam.
3. If printouts come out of the printer curled, you may be able to correct the problem by reversing the paper stack in the auxiliary tray so that the bottom of the stack faces up.
4. Avoid setting the paper guides so tightly that the paper stack bends.

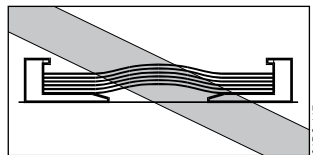

5. Avoid setting the paper guides so loosely that the paper stack is not evenly aligned.

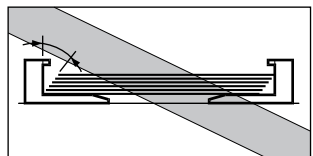

- Avoid setting the paper guides so loosely that there is space between the guides and the paper.

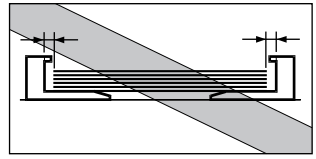

- Align the paper in the tray so that it is straight.

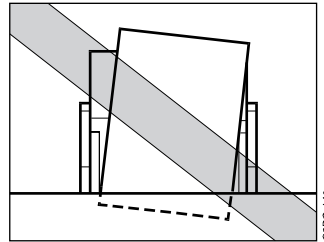

Loading Transparencies in the Auxiliary Tray

Load transparencies only in the auxiliary tray. You can load approximately 20 sheets at a time.

IBM recommends that you use only IBM transparencies for the best print quality. For ordering details, see “Ordering Supplies” on page 1–4, or contact your IBM service representative or authorized service dealer.

Remember that you can use only letter- or A4-size transparencies in this printer.

Transparencies have the following positioning markers to help you insert them correctly.

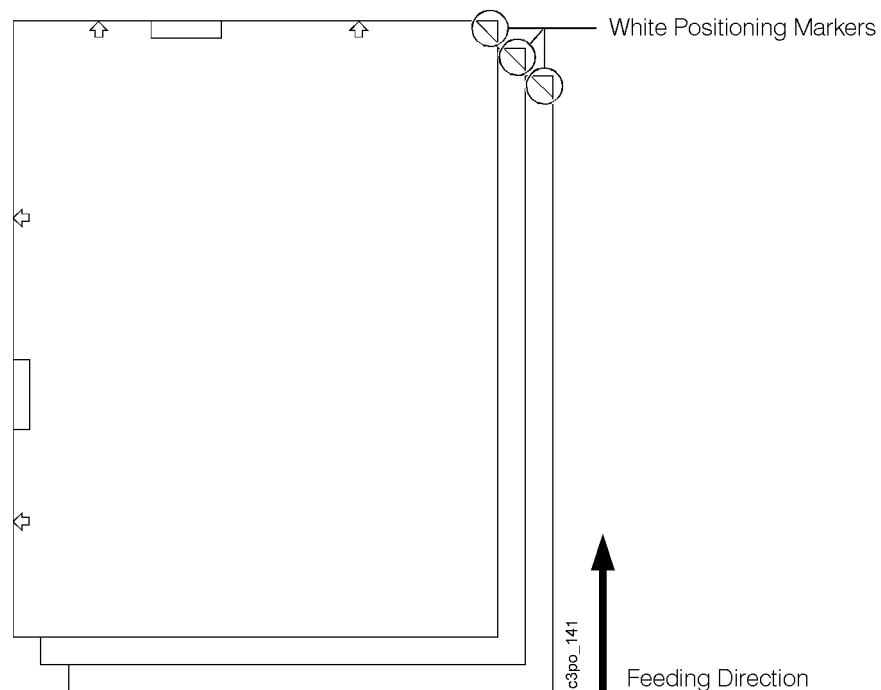

When you load transparencies, position each sheet so that the white positioning marker (triangle) is on the upper right side. In this position, the print side is the back side.

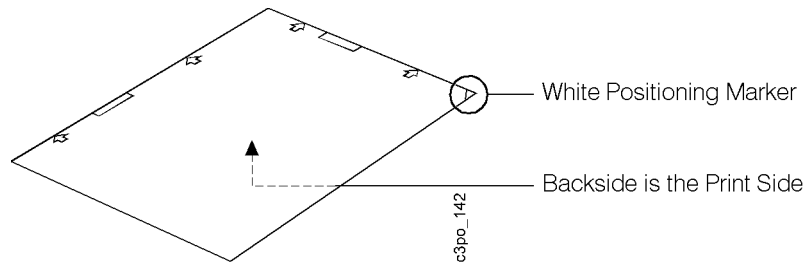

Use the following procedure to load transparencies.

1. Adjust the paper guides to accept transparencies (letter or A4 size).

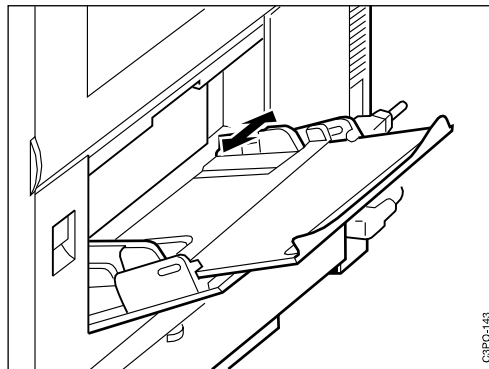

2. With the white positioning marker on the upper right side, tap a stack of transparencies on a flat surface to align its edges. When you tap, try to hold the edges of the transparencies and do not touch the print sides.

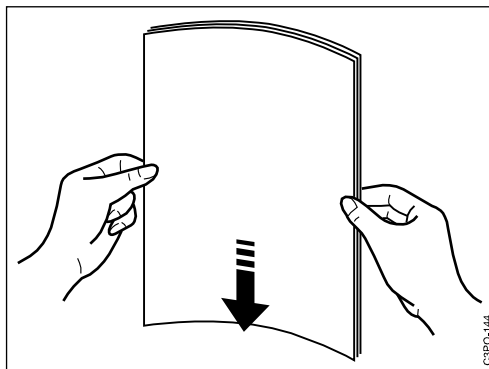

3. Before you load the transparencies, fan out small stacks of them to lessen the chance of feeding problems. Be careful not to scratch the transparency or leave fingerprints on the print sides.

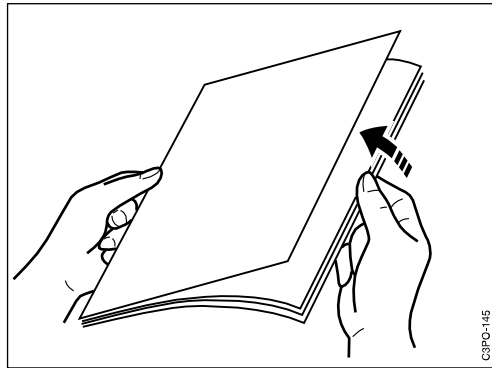

4. Position each sheet so that the white positioning marker is on the upper right side and push it as far as it can go into the printer.

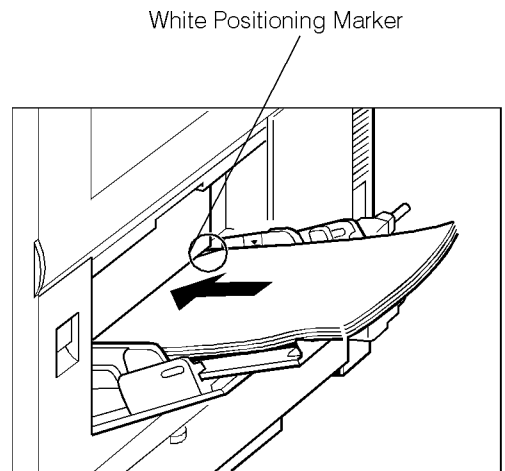

5. Check that you have not gone above the paper limit mark.

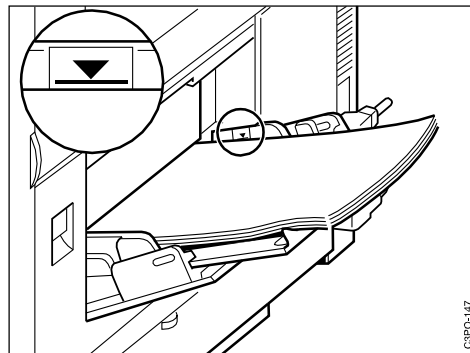

The auxiliary tray is now ready to supply transparencies.

Closing the Auxiliary Tray

Use the following procedure to close the auxiliary tray.

1. Lift the end of the extension tray slightly and push it into the auxiliary tray.

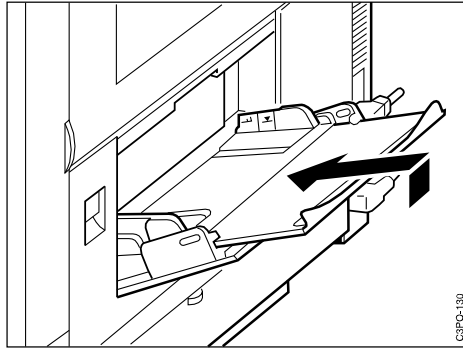

2. Close the auxiliary tray.

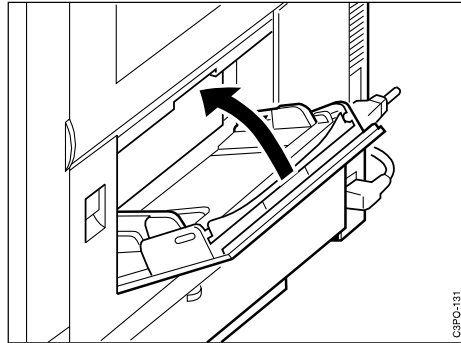

Choosing the Paper Output Tray

The printer has two methods of delivering paper. Which one you use depends on the paper type, the size of the document, or if you want your document collated. This section tells you how to use the side output tray and the top output tray.

Using the Side Output Tray

If the side output tray is open, printouts are delivered faceup into the tray. Use this delivery method for normal printing and when you print on heavy-weight paper. In contrast, if the side output tray is closed, printouts are delivered facedown into the top output tray (see “Using the Top Output Tray” on page 3–15).

The side output tray can hold 20 sheets of paper.

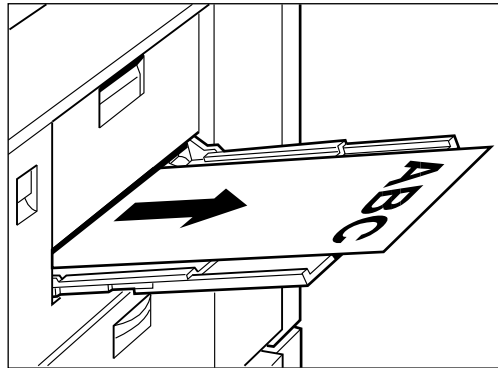

Note: When you print transparencies into the side output tray, be sure to remove each sheet as it is delivered into the tray. This lessens the chance of curling and jams.

Opening the Side Output Tray

Use the following procedure to open the side output tray.

1. Lift the latch to open the side output tray and pull the tray down.

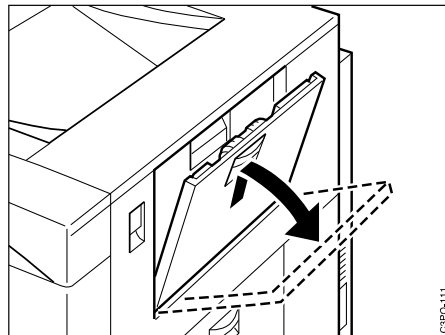

2. Pull on the extension tray grip to pull out the tray.

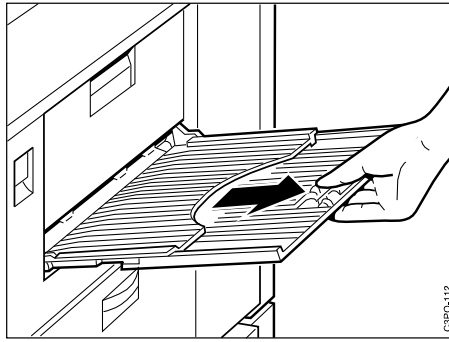

Closing the Side Output Tray

Use the following procedure to close the side output tray.

1. Push in the extension tray.

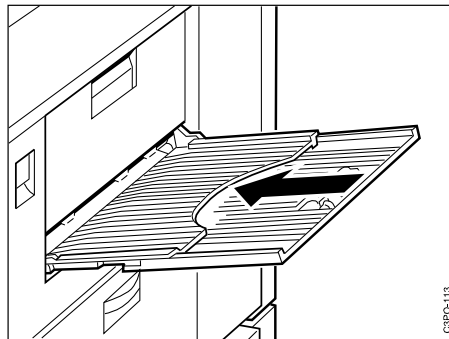

2. Close the side output tray until it snaps into place.

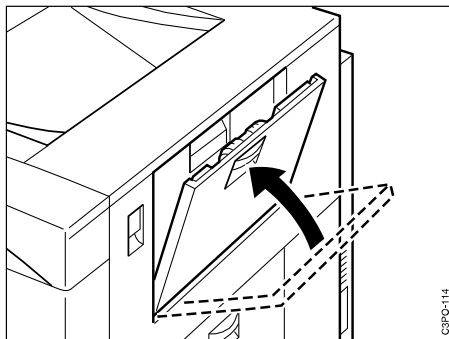

Using the Top Output Tray

If you want to direct printouts into the top output tray, close the side output tray. Printouts then come into the top output tray facedown and stacked in order. This is handy when you want to collate your documents. Also, if you print large jobs, use the top output tray because it holds up to 100 sheets of paper at 80 g/m².

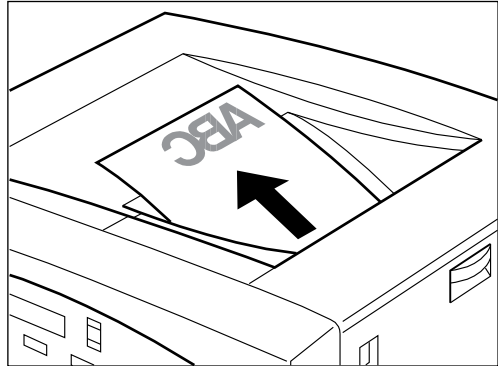

Chapter 4. Using the Operator Panel

This chapter tells you how the operator panel works and how to use menus on the display panel.

This chapter covers the following topics:

Identifying Each Part of the Operator Panel	4-2
Lights	4-2
Online Push Button and Light	4-2
Cancel Push Button	4-3
Display Panel	4-3
Control Push Buttons	4-3
Paper Source Lights	4-4
Canceling a Print Job	4-5
Understanding the Menus	4-6
Navigating the Menus	4-7
Choosing a Menu Setting	4-7
Using the Online Menu (Print Pages Menu)	4-8
Printing the Help Map	4-9
Printing a Job Log	4-9
Printing a Configuration Page	4-9
Printing a Test Page	4-10
Printing the Color Pages	4-10
Printing the Font Page	4-10
Using the Offline Menus	4-11
Entering a Password	4-13
Using the Printer Setup Menu	4-14
Choosing the Paper Source	4-14
Choosing the Paper Size	4-15
Choosing the Color Mode	4-16
Choosing to Print a Cover Page	4-16
Choosing to Print When There Is a PostScript Error	4-17
Choosing to Print a Start Page	4-18
Using the System Setup Menu	4-19
Setting the Printer Name	4-20
Setting the Time and Date	4-20
Changing the Password	4-21
Setting the Power Savings Mode	4-23
Using the Language Menu	4-24
Changing the Language	4-24
Language Menu Settings	4-24

Identifying Each Part of the Operator Panel

This section identifies the parts of the operator panel. Use the lights and push buttons on the operator panel to control the printer and to learn its status.

Following is an illustration of the operator panel and a description of each of its parts.

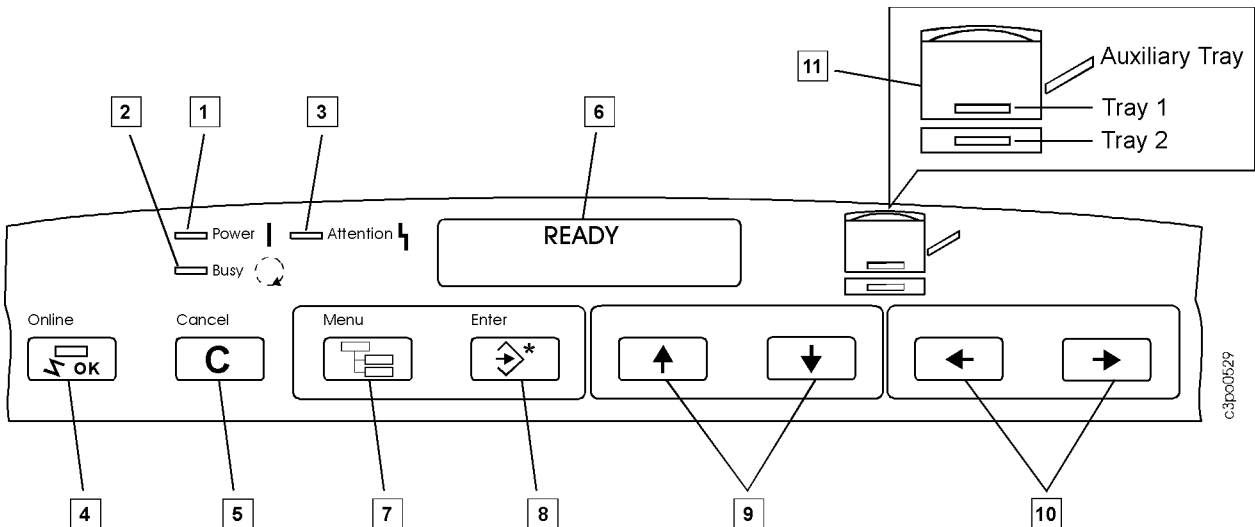

1 through 3 Lights

- 1 **Power**
The **Power** light is green. When it is lit, the printer is on.
- 2 **Busy**
The **Busy** light is green. When it is lit, the printer is processing or printing a job.
- 3 **Attention**
The **Attention** light is yellow. It flashes to alert you to an error or warning condition.

4 Online Push Button and Light

Press the **Online** push button to take the printer online or offline. Online means that the printer is communicating with the network. Offline means that the printer is not communicating with the network.

When you take the printer offline,

- A job that is printing finishes printing before the printer goes offline.
- A job that is spooling to a queue finishes spooling before the printer goes offline.
- The printer does not accept jobs to be spooled or printed.

Press the **Online** push button to take the printer online again.

The **Online** light shows the status of the printer. This table tells you what each kind of **Online** light means.

Light	What it means
Solid green	The printer is processing or printing a job or communicating with a remote computer (for example, through the printer Spooler utility).
Flashing green	The printer is preparing to go offline.
Off	The printer is offline or is starting up.

5 Cancel Push Button

Press the **Cancel** push button to stop printing the current job. If no job is printing, pressing the **Cancel** push button deletes the oldest job from the printer's queue.

6 Display Panel

The display panel tells you about the status of the printer, shows menu information, and enables you to view and edit information to configure the printer.

You can see three types of messages on the display panel: error messages, status messages, and warning messages. See Chapter 7, "Understanding Operator Messages," for a description of each of these message types.

7 through 10 Control Push Buttons

7 Menu

Press the **Menu** push button to see menus on the display panel.

This table shows you the relationship between the online/offline status and the function of the **Menu** push button.

When you are...	Press the Menu push button to...
Online	Access the Print Pages menu
Offline and not in any menu	Enter the Setup menu
Offline at the top level of a menu	Exit the Setup menu
Inside a menu, displaying an item	Go up 1 level in the menu structure

8 Enter

Use the **Enter** push button as shown in the following table.

When you...	Press the Enter push button to...
See the Attention light flash but there is no error message on the display panel	See 1 or more warning messages
See warning messages on the display panel	See the current status message
See a Setup menu	Choose the menu on line 2 of the display panel and access the next level of menus
See a menu setting	Make that setting the current one. The current setting has an asterisk (*) in column 1 of the display. When you exit the Setup menu, answer YES to the SAVE CHANGES message to save that setting.

9 Menu Scrolling

These arrows are called the **Menu Scrolling** push buttons in this publication. Use the **Menu Scrolling** push buttons to scroll through a menu and the settings in a menu. The up push button (↑) shows the previous menu or setting; the down push button (↓) shows the next menu or setting.

If you see a warning message with a (+) in the rightmost column of the display, you also can use these push buttons to display additional warning messages.

10 Cursor Position

These arrows are called the **Cursor Position** push buttons in this publication. Use the **Cursor Position** push buttons to enter text and numbers for some menu settings (such as a password or a numeric setting). The right push button (→) moves the cursor one position to the right. The left push button (←) moves the cursor one position to the left.

11 Paper Source Lights

The paper source lights show whether the paper is coming from tray 1, tray 2, or the auxiliary tray.

Canceling a Print Job

This section tells you how to cancel a print job.

Press the **Cancel** push button to cancel the job that is currently printing. If no job is printing, **Cancel** removes the job being processed (the oldest job). You must be online for **Cancel** to work.

Understanding the Menus

This section tells you how to navigate and choose from the menus you see on the display panel. The menu groups, menus, and items in a menu are shown in the table below.

Menu Group	Menu	Item
ONLINE	PRINT PAGES	HELP MAP JOB LOG CONFIGURATION TEST PAGE COLOR PAGES ERROR LOG FUSER TEST PAGE FONT PAGE
OFFLINE	LANGUAGE	ENGLISH (default) FRANÇAIS DEUTSCH ITALIANO ESPAÑOL PORTUGUES NEDERLANDS NORSK SVENSKA DANSK SUOMI
	RUN SETUP	PRINTER SETUP QUEUE SETUP CLEAR LOG/QUEUES SYSTEM SETUP NETWORK SETUP
	PRINTER SETUP	PAPER SOURCE PAPER SIZE COLOR MODE PRINT COVER PAGE PRINT TO PSERROR PRINT START PAGE
	QUEUE SETUP	This menu is used by the system administrator. See the <i>Administrator's Guide</i> .
	CLEAR LOG/QUEUES	This menu is used by the system administrator. See the <i>Administrator's Guide</i> .
	SYSTEM SETUP	PRINTER NAME DATE SYSTEM TIME CHANGE PASSWORD POWER SVNGS
	NETWORK SETUP	This menu is used by the system administrator. See the <i>Administrator's Guide</i> .

Navigating the Menus

Use the following procedure to navigate the menus.

1. Choose the online or offline menu group by toggling the **Online** push button between online and offline. Use the table below to find the menu you want.

Menu Group	Menu	Where to Find an Explanation
ONLINE	PRINT PAGES	See "Using the Online Menu (Print Pages Menu)" on page 4–8.
OFFLINE	RUN SETUP	See "Using the Offline Menus" on page 4–11.
	LANGUAGE	See "Using the Language Menu" on page 4–24.

2. Press the **Menu** push button.
3. Press the **Menu Scrolling** push buttons (↑↓) to scroll through the items. If you continue to hold down a **Menu Scrolling** push button, the scrolling speeds up.
4. When you see the item you want, press the **Enter** push button to go to the next menu level.
5. Choose a menu setting (see "Choosing a Menu Setting" on page 4–7) and press the **Enter** push button. You see the next item, if any.

Choosing a Menu Setting

To choose a menu setting, do one of the following:

1. Choose from the settings you see on the display panel. An example is when you use the **Menu Scrolling** push buttons (↑↓) to show you YES or NO and then you press the **Enter** push button to choose the setting that you see on the display panel.
2. Enter a setting 1 character at a time (such as a password or printer name).
 - a. Use the **Menu Scrolling** push buttons (↑↓) to choose the first alphanumeric character you want on the second line of the display panel. You can use capital letters, small letters, and numerals.
 - b. Use the right **Cursor Position** push button (→) to advance the cursor to the next character position.

If you need to correct a character in a previous character position, use the left **Cursor Position** push button (←) to move the cursor to the position you want to correct.
 - c. Repeat step a and step b for each character you want.
 - d. When you finish, press the **Enter** push button.

Using the Online Menu (Print Pages Menu)

The online menu consists of the Print Pages menu. The Print Pages menu allows you to print information stored in the printer to help solve problems and to see the printer's configuration.

The Help Map and the configuration page give you valuable information about using the printer. Print these pages and keep them near the printer.

If you need to call for service, make sure that you have a configuration page available to help you tell the service representative about the printer.

Accessing the Print Pages Menu

Use the following procedure to access the Print Pages menu.

1. Check that the printer is online (the **Online** light is on). If the printer is not online, press the **Online** push button.
2. Check that the **Attention** light is not on. If it is, see Chapter 7, "Understanding Operator Messages," and take appropriate action.
3. Press the **Menu** push button. You see PRINT PAGES on the first line of the display panel.

Print Pages Menu

This table shows you the items in the Print Pages menu and tells you where to find an explanation of each item.

Print Pages Menu	
Item	Where to Find an Explanation
HELP MAP	Prints a Help Map. See "Printing the Help Map" on page 4–9.
JOB LOG	Prints a Job Log. See "Printing a Job Log" on page 4–9.
CONFIGURATION	Prints a configuration page. See "Printing a Configuration Page" on page 4–9.
TEST PAGE	Prints a test page. See "Printing a Test Page" on page 4–10.
COLOR PAGES	Prints the color pages. See "Printing the Color Pages" on page 4–10.
FONT PAGE	Prints a font page. See "Printing the Font Page" on page 4–10.
ERROR LOG	These are diagnostic printouts that service personnel may ask you to print.
FUSER TEST PAGE	

Printing the Help Map

Use the following procedure to print the Help Map. This map tells you about the operator panel, push buttons, and panel lights and lists all the menus.

1. Go to the Print Pages menu (see “Accessing the Print Pages Menu” on page 4–8).
2. When you choose the Print Pages menu, you see HELP MAP on the second line of the display panel.
3. Press the **Enter** push button. Several messages appear on the display panel that tell you what the printer is doing until the Help Map is printed.
4. You see READY when the print job is finished.

Printing a Job Log

Use the following procedure to print a job log of the last 40 jobs. The log includes information such as user name, document name, time and date printed, and number of pages printed for each job.

1. Go to the Print Pages menu (see “Accessing the Print Pages Menu” on page 4–8).
2. Use the **Menu Scrolling** push buttons (↑↓) to scroll through the Print Pages menu until you see JOB LOG on the second line of the display panel.
3. Press the **Enter** push button. Several messages appear on the display panel that tell you what the printer is doing until the Job Log is printed.
4. You see READY when the print job is finished.

Printing a Configuration Page

Use the following procedure to print a configuration page listing the current server and printer configuration. This page shows you the settings for the Printer, Queue, Job Log, and Network Setup menus (see “Offline Menus” on page 4–11) and shows you the total print count.

1. Go to the Print Pages menu (see “Accessing the Print Pages Menu” on page 4–8).
2. Use the **Menu Scrolling** push buttons (↑↓) to scroll through the Print Pages menu until you see CONFIGURATION on the second line of the display panel.
3. Press the **Enter** push button. Several messages appear on the display panel that tell you what the printer is doing until the configuration page is printed.
4. You see READY when the print job is finished.

Printing a Test Page

Use the following procedure to print a test page. This page shows you samples of color and grayscale that you can use to determine whether or not you are printing correctly from an application. The test page also shows you the printer name, printer model, color mode, print count, calibration, memory multiplier setting, color-rendering dictionary, and date and time printed.

1. Go to the Print Pages menu (see “Accessing the Print Pages Menu” on page 4–8).
2. Use the **Menu Scrolling** push buttons (↑↓) to scroll through the Print Pages menu until you see TEST PAGE on the second line of the display panel.
3. Press the **Enter** push button. Several messages appear on the display panel that tell you what the printer is doing until the test page is printed.
4. You see READY when the print job is finished.

Printing the Color Pages

Use the following procedure to print the color pages. These pages display the RGB, CMYK, and Pantone colors available from the printer. Use these pages to help you choose colors when working with illustration and desktop publishing software applications.

1. Go to the Print Pages menu (see “Accessing the Print Pages Menu” on page 4–8).
2. Use the **Menu Scrolling** push buttons (↑↓) to scroll through the Print Pages menu until you see COLOR PAGES on the second line of the display panel.
3. Press the **Enter** push button. Several messages appear on the display panel that tell you what the printer is doing until the color pages are printed.
4. You see READY when the print job is finished.

Printing the Font Page

Use the following procedure to print the font page. This page shows the PostScript fonts that are resident in the printer.

1. Go to the Print Pages menu (see “Accessing the Print Pages Menu” on page 4–8).
2. Use the **Menu Scrolling** push buttons (↑↓) to scroll through the Print Pages menu until you see FONT PAGE on the second line of the display panel.
3. Press the **Enter** push button. Several messages appear on the display panel that tell you what the printer is doing until the font page is printed.
4. You see READY when the print job is finished.

Using the Offline Menus

Use the offline menu group to define the printer's default settings. From the offline menu group, choose the Run Setup or Language menu. From these menus, access menus such as Printer Setup or System Setup. (See the table in "Understanding the Menus" on page 4–6.)

Because some of the offline menus are for your system administrator to use, they are covered in the *Administrator's Guide*.

Note: If your system administrator has assigned a password for the Run Setup menus, you need that password to use the menus.

Offline Menus

This table shows you the menus you can access from the offline menu group and explains how to use them.

Offline Menus		
Menu	Item	Function
RUN SETUP	PRINTER SETUP	Use to specify the way print jobs are managed on the printer, such as setting the paper size or printing a start page. See "Using the Printer Setup Menu" on page 4–14.
	QUEUE SETUP	Use to enable or disable print queues and to specify how or if print jobs are queued. See the <i>Administrator's Guide</i> for more information.
	JOB LOG SETUP	Use to specify whether or not the Job Log should print automatically and be cleared automatically. See the <i>Administrator's Guide</i> for more information.
	CLEAR LOG/QUEUES	Use to erase the Job Log and any jobs stored in the printer queues. See the <i>Administrator's Guide</i> for more information.
	SYSTEM SETUP	Use to specify the printer system settings, such as time, date, and printer name. See "Using the System Setup Menu" on page 4–19.
	NETWORK SETUP	Use to activate and configure network systems that transfer jobs to the printer. See the <i>Administrator's Guide</i> for more information.
	EXIT SETUP	Use to exit the setup menus and save any changes that you made.
LANGUAGE	<i>Choice of languages</i>	Use to choose the language of the text on the display panel. See "Changing the Language" on page 4–24.

Accessing the Offline Menu

Use the following procedure to access the offline menu.

1. Check that the printer is offline (the **Online** light is *not* on). If the printer is not offline, press the **Online** push button.

Note: If the printer is communicating with a utility when you take it offline, the printer remains in an “offline pending” state until the utility is disengaged.

2. Press the **Menu** push button. You see SELECT FUNCTION on the first line of the display panel.
3. Use the **Menu Scrolling** push buttons (↑↓) to scroll through the items until you see the one you want. Press the **Enter** push button to select the item that you want.

For more information on the menus, see the table under “Understanding the Menus” on page 4–6.

Entering a Password

If your system administrator has assigned a password for the Run Setup menu, use the following procedure to enter that password.

1. When a password is required, you see ENTER PASSWORD on the display panel. Use the **Menu Scrolling** push buttons (↑↓) to set the first alphanumeric character of the password on the second line of the display panel.
2. Use the right **Cursor Position** push button (→) to advance the cursor to the next character position.
3. Repeat step 1 and step 2 for each character in the password.
4. When you finish entering the password, press the **Enter** push button.
 - a. If you entered the right password, you see PRINTER SETUP on the second line of the display panel.
 - b. If you entered a wrong password, you see PASSWORD INCORRECT on the display panel. Press the **Enter** push button. You see TRY AGAIN on line 1. Press the **Enter** push button and repeat step 1 through step 4.

Deleting a Password

If you forget the password or no longer want to use one, use the following procedure to delete the password.

1. Turn off the printer.
2. Turn on the printer.
3. Watch closely to see the message PRESS MENU FOR SETUP on the display panel. When you see the message, press the up and down **Menu Scrolling** push buttons (↑↓) *at the same time*.
4. You see on the display panel DELETING SETTINGS... and PLEASE WAIT, STARTING UP. When the printer completes its startup procedure, you may access the offline menus to set a new password (see “Changing the Password” on page 4–21) or return to a READY state.

Changing a Password

See “Changing the Password” on page 4–21 for information about how to change a password.

Using the Printer Setup Menu

Use this menu to set commonly used printer specifications such as paper size and paper source.

Accessing the Printer Setup Menu

Use the following procedure to access the Printer Setup menu.

1. Check that the printer is offline (the **Online** light is *not* on). If the printer is not offline, press the **Online** push button.
2. Press the **Menu** push button. You see SELECT FUNCTION on the first line of the display panel and RUN SETUP on the second line.
3. Press the **Enter** push button. If your system administrator has set a password for the Run Setup menu, you must enter that password now. See “Entering a Password” on page 4–13 to learn how to do this.
4. You see SETUP MENU on the first line of the display panel and PRINTER SETUP on the second line.
5. Press the **Enter** push button. PRINTER SETUP moves to the first line of the display panel, and you see PAPER SOURCE on the second line.

Printer Setup Menu

This table shows you the items on the Printer Setup menu and tells you where to find an explanation of each item.

Printer Setup Menu Items	
Item	Where to Find an Explanation
PAPER SOURCE	See “Choosing the Paper Source” on page 4–14.
PAPER SIZE	See “Choosing the Paper Size” on page 4–15.
COLOR MODE	See “Choosing the Color Mode” on page 4–16.
PRINT COVER PAGE	See “Choosing to Print a Cover Page” on page 4–16.
PRINT TO PSERROR	See “Choosing to Print When There Is a PostScript Error” on page 4–17.
PRINT START PAGE	See “Choosing to Print a Start Page” on page 4–18.

Choosing the Paper Source

Note: The setting you choose here is used only for jobs that do not specify a paper source.

Use the following procedure to choose the paper source that feeds the printer.

1. Go to the Printer Setup menu (see “Accessing the Printer Setup Menu” on page 4–14).
2. When you choose the Printer Setup menu, you see PAPER SOURCE on the second line of the display panel.
3. Press the **Enter** push button. PAPER SOURCE moves up to the first line of the display panel and you see TRAY 1 on the second line of the display panel.

4. Use the **Menu Scrolling** push buttons (↑↓) to scroll through the available settings, TRAY 1, TRAY 2, AUXILIARY TRAY, or AUTO SELECT. If you choose AUTO SELECT and if tray 1 or tray 2 runs out of paper, the printer feeds paper from the other tray (tray 1 or tray 2) that matches the paper size in the tray that ran out. TRAY 1 is the default.
5. When you see the setting you want, press the **Enter** push button.
6. Press the **Menu** push button 3 times. You see EXIT SETUP on the first line of the display panel and the default setting, NO, on the second line.
7. Press the down **Menu Scrolling** push button (↓) to see YES on the second line.
8. Press the **Enter** push button. You see SAVE CHANGES on the first line of the display panel and the default setting, YES, on the second line. Press the **Enter** push button to save the changes.

Choosing the Paper Size

Note: The setting you choose here is used only for jobs that do not specify a paper size.

Use the following procedure to choose the size of paper to print on.

1. Go to the Printer Setup menu (see “Accessing the Printer Setup Menu” on page 4–14).
2. Use the **Menu Scrolling** push buttons (↑↓) to scroll through the items until you see PAPER SIZE on the second line of the display panel.
3. Press the **Enter** push button. PAPER SIZE moves up to the first line of the display panel and you see LETTER on the second line of the display panel.
4. Use the **Menu Scrolling** push buttons (↑↓) to scroll through the available settings. You can choose to print on the following paper sizes:
 - English paper sizes (LETTER [8.5 x 11 inch] or LEGAL [8.5 x 14 inch])
 - metric (ISO) paper sizes (A4 [210 x 297 mm] or JIS B5 [182 x 277 mm]).The default paper size is LETTER. For transparencies, you can choose only LETTER or A4.
5. When you see the setting you want, press the **Enter** push button.
6. Press the **Menu** push button 3 times. You see EXIT SETUP on the first line of the display panel and the default setting, NO, on the second line.
7. Press the down **Menu Scrolling** push button (↓) to see YES on the second line.
8. Press the **Enter** push button. You see SAVE CHANGES on the first line of the display panel and the default setting, YES, on the second line. Press the **Enter** push button to save the changes.

Choosing the Color Mode

Note: The setting you choose here is used only for jobs that do not specify a color mode.

Use the following procedure to choose whether to print color or grayscale images.

1. Go to the Printer Setup menu (see “Accessing the Printer Setup Menu” on page 4–14).
2. Use the **Menu Scrolling** push buttons (↑↓) to scroll through the items until you see COLOR MODE on the second line of the display panel.
3. Press the **Enter** push button. COLOR MODE moves up to the first line of the display panel and you see CMYK on the second line of the display panel.
4. Use the **Menu Scrolling** push buttons (↑↓) to scroll through the available settings, CMYK or GRAYSCALE. CMYK is the default.
5. When you see the setting you want, press the **Enter** push button.
6. Press the **Menu** push button 3 times. You see EXIT SETUP on the first line of the display panel and the default setting, NO, on the second line.
7. Press the down **Menu Scrolling** push button (↓) to see YES on the second line.
8. Press the **Enter** push button. You see SAVE CHANGES on the first line of the display panel and the default setting, YES, on the second line. Press the **Enter** push button to save the changes.

Choosing to Print a Cover Page

Use the following procedure to choose whether or not the printer prints a cover page. If you choose to print a cover page, each print job is preceded by a job summary page that shows the name of the user who sent the job, the document name, the printer name, the time the job was printed, the number of pages printed, and the status of the job.

1. Go to the Printer Setup menu (see “Accessing the Printer Setup Menu” on page 4–14).
2. Use the **Menu Scrolling** push buttons (↑↓) to scroll through the items until you see PRINT COVER PAGE on the second line of the display panel.
3. Press the **Enter** push button. PRINT COVER PAGE moves up to the first line of the display panel and you see NO on the second line of the display panel.
4. Use the **Menu Scrolling** push buttons (↑↓) to scroll through the available settings, YES and NO. NO is the default to save printing time and paper.

Note: If you set this and the PRINT TO PSERROR setting to YES, when there is a PostScript error, the error message is printed on the cover page.

5. When you see the setting you want, press the **Enter** push button.

6. Press the **Menu** push button 3 times. You see EXIT SETUP on the first line of the display panel and the default setting, NO, on the second line.
7. Press the down **Menu Scrolling** push button (↓) to see YES on the second line.
8. Press the **Enter** push button. You see SAVE CHANGES on the first line of the display panel and the default setting, YES, on the second line. Press the **Enter** push button to save the changes.

Choosing to Print When There Is a PostScript Error

Use the following procedure to choose whether or not the printer prints the available portion of a print job when there is a PostScript error.

1. Go to the Printer Setup menu (see “Accessing the Printer Setup Menu” on page 4–14).
2. Use the **Menu Scrolling** push buttons (↑↓) to scroll through the items until you see PRINT TO PSERROR on the second line of the display panel.
3. Press the **Enter** push button. PRINT TO PSERROR moves up to the first line of the display panel and you see NO on the second line of the display panel.
4. Use the Menu Scrolling push buttons (↑↓) to scroll through the available settings, YES and NO. Choose YES to print the portion of the job processed before the error. Choose NO to cancel printing when there is a PostScript error. NO is the default.

Notes:

1. If you have trouble printing a PostScript job, consider setting PRINT TO PSERROR to YES. This allows you to see where the job stopped and the PostScript error near the last page printed.
2. If you print large PostScript jobs, consider setting PRINT TO PSERROR to NO. A large PostScript job might stop after 2/3 of the job is finished and tie up the printer.
3. If you set both the PRINT TO PSERROR and the PRINT COVER PAGE settings to YES, the PostScript error message is printed on the cover page as the job status.
5. When you see the setting you want, press the **Enter** push button.
6. Press the **Menu** push button 3 times. You see EXIT SETUP on the first line of the display panel and the default setting, NO, on the second line.
7. Press the down **Menu Scrolling** push button (↓) to see YES on the second line.
8. Press the **Enter** push button. You see SAVE CHANGES on the first line of the display panel and the default setting, YES, on the second line. Press the **Enter** push button to save the changes.

Choosing to Print a Start Page

Use the following procedure to choose whether or not the printer prints a start page when you turn the power on. The start page shows the current date, last calibration date, color mode and printer mode, amount of memory installed in the printer, network protocols enabled, and connections enabled.

1. Go to the Printer Setup menu (see “Accessing the Printer Setup Menu” on page 4–14).
2. Use the **Menu Scrolling** push buttons (↑↓) to scroll through the items until you see PRINT START PAGE on the second line of the display panel.
3. Press the **Enter** push button. PRINT START PAGE moves up to the first line of the display panel and you see YES on the second line of the display panel.
4. Use the **Menu Scrolling** push buttons (↑↓) to scroll through the available settings, YES and NO. YES is the default.
5. When you see the setting you want, press the **Enter** push button.
6. Press the **Menu** push button 3 times. You see EXIT SETUP on the first line of the display panel and the default setting, NO, on the second line.
7. Press the down **Menu Scrolling** push button (↓) to see YES on the second line.
8. Press the **Enter** push button. You see SAVE CHANGES on the first line of the display panel and the default setting, YES, on the second line. Press the **Enter** push button to save the changes.

Using the System Setup Menu

Use the System Setup menu to change the printer name, date, and system time and to set or change the password and the Power Savings mode. The following sections tell you how to use the System Setup menu.

Accessing the System Setup Menu

Use the following procedure to access the System Setup menu.

1. Check that the printer is offline (the **Online** light is *not* on). If the printer is not offline, press the **Online** push button.
2. Press the **Menu** push button. You see SELECT FUNCTION on the first line of the display panel and RUN SETUP on the second line.
3. Press the **Enter** push button. If your system administrator has assigned a password for the Run Setup menu, enter that password now. See “Entering a Password” on page 4–13.
4. Press the **Enter** push button. You see SETUP MENU on the first line of the display panel and PRINTER SETUP on the second line.
5. Use the **Menu Scrolling** push buttons (↑↓) to scroll through the menus until you see SYSTEM SETUP.
6. Press the **Enter** push button. SYSTEM SETUP moves to the first line of the display panel, and you see PRINTER NAME on the second line.

You are now in the System Setup menu. Read the following sections to learn how to use this menu.

System Setup Menu

This table shows you the items on the System Setup menu and tells you where to find an explanation of each item.

System Setup Menu Items	
Item	Where to Find an Explanation
PRINTER NAME	Change the printer name. See “Setting the Printer Name” on page 4–20.
DATE (format)	Change the current date. See “Setting the Time and Date” on page 4–20.
SYSTEM TIME	Change the current time. See “Setting the Time and Date” on page 4–20.
CHANGE PASSWORD	Set or change the password for the printer. See “Changing the Password” on page 4–21.
POWER SVNGS	Set or change the amount of time that the printer remains idle before changing to a low power consumption mode (Energy Star). See “Setting the Power Savings Mode” on page 4–23.

Setting the Printer Name

Use the following procedure to change the name by which the printer is identified on the network. Choose a name that clearly identifies the printer to users, such as IBM 4303 Color. The default name is IBMnetcolor.

1. Access the System Setup menu (see “Accessing the System Setup Menu” on page 4–19). You see PRINTER NAME on the second line of the display panel.
2. Press the **Enter** push button. PRINTER NAME moves up to the first line of the display panel and you see the current printer name on the second line. Enter the new printer name as follows:
 - a. Use the **Menu Scrolling** push buttons (↑↓) to change the first alphanumeric character of the printer name on the second line of the display panel.
 - b. Use the right **Cursor Position** push button (→) to advance the cursor to the next character position.
 - c. Repeat step 1 and step 2 for each character in the printer name.
 - d. When you finish entering the printer name, press the **Enter** push button.
3. Press the **Menu** push button 3 times. You see EXIT SETUP on the first line of the display panel and the default setting, NO, on the second line.
4. Press the down **Menu Scrolling** push button (↓) to see YES on the second line.
5. Press the **Enter** push button. You see SAVE CHANGES on the first line of the display panel and the default setting, YES, on the second line. Press the **Enter** push button to save the changes.

Setting the Time and Date

Use the following procedure to change the current time and date.

1. Access the System Setup menu (see “Accessing the System Setup Menu” on page 4–19).
2. Use the **Menu Scrolling** push buttons (↑↓) to scroll through the items until you see DATE on the second line of the display panel.
3. Press the **Enter** push button. DATE moves up to the first line of the display panel and you see the date that is stored in the printer’s clock on the second line. Enter the new date, using the MM/DD/YY (month/day/year) format (or the format that applies in your language), as follows:
 - a. Use the **Menu Scrolling** push buttons (↑↓) to change the first number of the date on the second line of the display panel.
 - b. Use the right **Cursor Position** push button (→) to advance the cursor to the next number position.
 - c. Repeat step 1 and step 2 for each number in the date.
4. Press the **Enter** push button. You see the next menu, SYSTEM TIME, on the second line of the display panel.

5. Press the **Enter** push button. SYSTEM TIME moves up to the first line of the display panel and you see the system time that is stored on the printer's clock on the second line. Enter the new time, based on the 24-hour clock, in the form HH:MM (hours:minutes) as follows:
 - a. Use the **Menu Scrolling** push buttons ($\uparrow\downarrow$) to change the first number of the time on the second line of the display panel.
 - b. Use the right **Cursor Position** push button (\rightarrow) to advance the cursor to the next number position.
 - c. Repeat step 1 and step 2 for each number in the time.
6. Press the **Menu** push button 3 times. You see EXIT SETUP on the first line of the display panel and the default setting, NO, on the second line.
7. Press the down **Menu Scrolling** push button (\downarrow) to see YES on the second line.
8. Press the **Enter** push button. You see SAVE CHANGES on the first line of the display panel and the default setting, YES, on the second line. Press the **Enter** push button to save the changes.

Changing the Password

The Change Password menu item enables you to set or change the password for the printer. When a password is required, only someone who knows the password can use the Run Setup function to change the printer settings. In most cases, only the key operator knows the password.

When the printer is first set up, no password exists. If you want a password to be used, you must define it using this menu. If you did not create a password, no one is required to enter a password to use the Run Setup menu.

Use the Change Password function based on who should have access to the Setup menu. Access to the Setup menu enables you to choose commonly used printer settings such as paper type.

Remember that if you use the Change Password function to assign a password, *users who do not know the password cannot use the Setup menu.*

Use the following procedure to set or change a password.

1. Access the System Setup menu (see "Accessing the System Setup Menu" on page 4–19).
2. Use the **Menu Scrolling** push buttons ($\uparrow\downarrow$) to scroll through the items until you see CHANGE PASSWORD on the second line of the display panel.
3. Press the **Enter** push button. CHANGE PASSWORD moves up to the first line of the display panel and you see NO on the second line. NO is the default.
4. Press the down **Menu Scrolling** push button (\downarrow) to display YES on the second line of the display panel. Press the **Enter** push button.

5. You see NEW PASSWORD on the first line of the display panel. Enter the new password as follows. The password can be any combination of letters and numbers up to 20 characters.
 - a. Use the **Menu Scrolling** push buttons (↑↓) to change the first alphanumeric character of the password on the second line of the display panel.
 - b. Use the right **Cursor Position** push button (→) to advance the cursor to the next character position.
 - c. Repeat step 1 and step 2 for each character in the password.
 - d. When you finish entering the password, press the **Enter** push button.
6. You see VERIFY PASSWORD on the first line of the display panel. Repeat step 5.
7. If the password you entered in step 6 matches the one you entered in step 5, you see PASSWORD CHANGED on the display panel. If not, proceed to step 8.
 - a. Press the **Menu** push button 3 times. You see EXIT SETUP on the first line of the display panel and the default setting, NO, on the second line.
 - b. Press the down **Menu Scrolling** push button (↓) to see YES on the second line.
 - c. Press the **Enter** push button. You see SAVE CHANGES on the first line of the display panel and the default setting, YES, on the second line. Press the **Enter** push button to save the changes.
8. If the password you entered in step 6 does not match the one you entered in step 5, you see PASSWORD INCORRECT on the display panel. Press the **Enter** push button. You see TRY AGAIN on the first line of the display panel. Press the **Enter** push button and repeat step 6.

The new password is effective until you change it again.

Setting the Power Savings Mode

Use the following procedure to set or change the Power Savings mode. The Power Savings mode allows you to set the amount of time that the printer remains idle before it changes to a low power consumption mode (Energy Star). You can set a time from 15–120 minutes in increments of 15 minutes.

1. Access the System Setup menu (see “Accessing the System Setup Menu” on page 4–19).
2. Use the **Menu Scrolling** push buttons (↑↓) to scroll through the items until you see POWER SVNGS (M) on the second line of the display panel.
3. Press the **Enter** push button. POWER SVNGS moves up to the first line of the display panel and you see the current setting on the second line.
4. Use the **Menu Scrolling** push buttons (↑↓) to scroll through the available settings until you see the one that you want. 120 is the default. Press the **Enter** push button.
5. Press the **Menu** push button 3 times. You see EXIT SETUP on the first line of the display panel and the default setting, NO, on the second line.
6. Press the down **Menu Scrolling** push button (↓) to see YES on the second line.
7. Press the **Enter** push button. You see SAVE CHANGES on the first line of the display panel and the default setting, YES, on the second line. Press the **Enter** push button to save the changes.

Using the Language Menu

Use the Language menu to change the language that you see on the display panel.

Changing the Language

Use the following procedure to change the language.

1. Check that the printer is offline (the **Online** light is *not* on). If the printer is not offline, press the **Online** push button.
2. Press the **Menu** push button. You see SELECT FUNCTION on the first line of the display panel and RUN SETUP on the second line.
3. Press the down **Menu Scrolling** push button (↓). You see LANGUAGE on the second line of the display panel.
4. Press the **Enter** push button. LANGUAGE moves up to the first line of the display panel and you see the language setting ENGLISH on the second line. ENGLISH is the default setting.
5. Use the **Menu Scrolling** push buttons (↑↓) to scroll through the list of languages until you find the one you want.
6. Press the **Enter** push button to choose the language. See the Language Menu Settings table below for a list of the available settings.
7. Press the **Menu** push button to exit Run Setup.

Language Menu Settings

This table lists the languages that you can choose from the Language menu.

Language Menu Settings
ENGLISH (default)
FRANÇAIS
DEUTSCH
ITALIANO
ESPAÑOL
PORTUGUES
NEDERLANDS
NORSK
SVENSKA
DANSK
SUOMI

Chapter 5. Replacing Supplies

This chapter tells you how to replace the printer's toner cartridge, the used toner bottle, the fuser oil bottle, the fuser, and the photoconductor drum cartridge. It also tells you how to store and handle toner cartridges.

This chapter covers the following topics:

Storing and Handling Toner Cartridges	5-2
Replacing Toner Cartridges	5-4
Removing the Old Cartridge	5-5
Installing a New Cartridge	5-8
Recycling the Used Toner Cartridge	5-13
Replacing the Used Toner Bottle	5-14
Replacing the Fuser Oil Bottle	5-16
Removing the Old Fuser Oil Bottle	5-16
Installing the New Fuser Oil Bottle	5-17
Replacing the Fuser	5-19
Preparing the Fuser and Work Area	5-19
Unpacking the New Fuser	5-20
Removing the Fuser Oil from the Printer	5-21
Removing the Fuser Access Door	5-24
Removing the Used Fuser	5-26
Installing the New Fuser	5-27
Replacing the Fuser Access Door	5-29
Filling the New Fuser Unit with Fuser Oil	5-30
Printing Test Pages	5-31
Replacing the Photoconductor Drum Cartridge	5-33
Locating the Orange Photoconductor Drum Shield	5-33
Removing the Old Photoconductor Drum Cartridge	5-33
Installing a New Photoconductor Drum Cartridge	5-35
Recycling the Photoconductor Drum Cartridge	5-38
Cleaning the Separation Corona Wire	5-39

Storing and Handling Toner Cartridges

This section tells you how to store and handle toner cartridges. Follow these instructions:

- To avoid temporary problems caused by moisture, allow enough time for toner cartridges to stabilize in the printer's environment.
- Do not unseal or remove a toner cartridge from its protective package until it has reached room temperature (1–2 hours).
- Do not store the cartridges where they are exposed to direct sunlight.
- Do not store the cartridges at high temperature or high humidity, or where the temperature or humidity can change abruptly.
- Store the toner cartridges horizontally in a cool, dry place away from sunlight. The maximum storage temperature is 30°C (86°F). The maximum storage humidity is 80% without condensation.
- Do not store the cartridges in salty air or where there are corrosive gases such as aerosol spray.
- Remove the cartridges from the printer when you move the printer. Put the cartridges in their original protective bags to avoid exposure to light.
- Do not try to disassemble the cartridges.
- IBM recommends that you use only genuine IBM toner cartridges designed for this printer.
- The printer uses the rectangular, transparent windows at the top and bottom of a toner cartridge to detect the toner level. When you handle a toner cartridge, do not touch or scratch the windows. If you do, the toner-level detection mechanism may not work correctly.
- Be sure to replace a used toner cartridge with a cartridge of the same color. Never insert a toner cartridge if its color does not match the color markers on the turret. If you do, you may have problems printing.



<2-13> CAUTION:

Do not dispose of toner or toner containers in fire. Dispose of these in accordance with local regulations.



<2-9> CAUTION:

This printer may contain materials, either components or consumable supplies, that are regulated for disposal. Dispose of all items in accordance with local regulations.

Ordering Supplies

To order supplies for the printer, call **1-888-IBM-PRINT** in the U.S. and Canada. You may also contact your IBM marketing representative for information about how to order supplies.

Replacing Toner Cartridges

This section guides you through the following procedures:

- Removing an old toner cartridge from the printer
- Installing a new one
- Recycling the used one

Follow these instructions when you replace a toner cartridge:

- When you load a toner cartridge, make sure its color matches the color markers on the printer. The printer uses 4 color toner cartridges: cyan, magenta, yellow, and black. Each color cartridge has its own holder in the printer's turret.

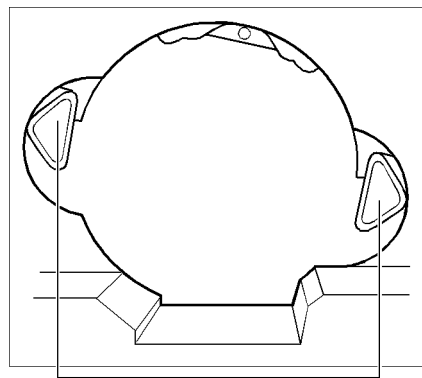

Color Markers on the Printer

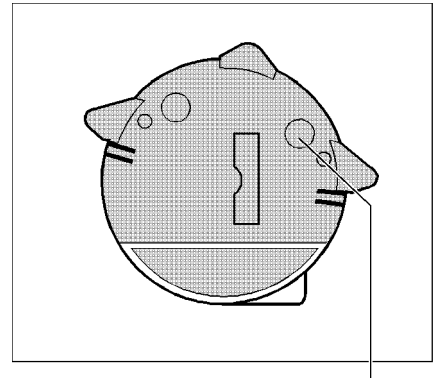

Color Marker on the Toner Cartridge

- Be sure to insert the cartridges correctly or you may damage the printer. Pull the eject handle only when the color markers are fully visible. Otherwise, the toner cartridge cannot pop out and this may damage the handle.
- Do not touch the sensing windows on the top and bottom of the cartridge.

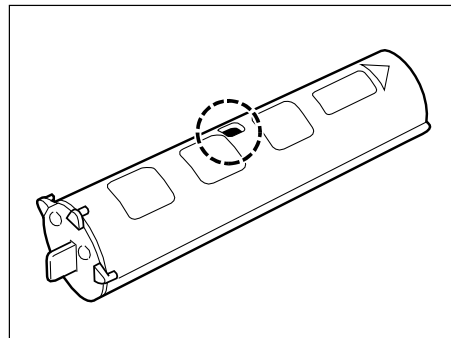

<2-13> CAUTION:

Do not dispose of toner or toner containers in fire. Dispose of these in accordance with local regulations.

Removing the Old Cartridge

Use the following procedure to remove the old toner cartridge from the printer.

Attention:

Be careful when you handle toner cartridges. The used toner cartridges have no seal so some toner may spill.

1. Open the front door.

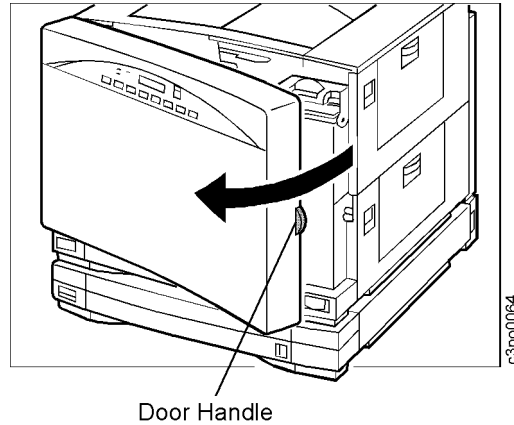

2. Find the turret rotation knob.

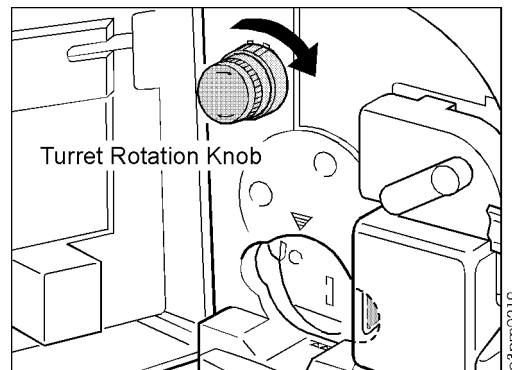

3. Use the turret rotation knob as follows:
 - a. Push the knob in [1] and turn it clockwise about the distance between arrow [1] and arrow [2].
 - b. Release the knob [2].
 - c. Turn the knob clockwise [3].
 - d. When the turret is positioned to release a cartridge, the knob moves outward [4] and locks.

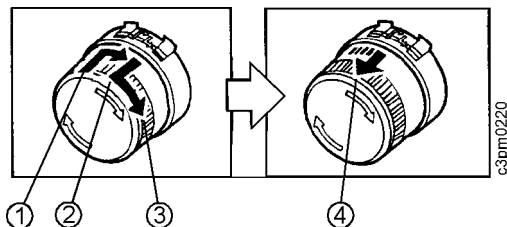

- e. When the color markers on the toner cartridge match the color markers on the turret, the toner cartridge is positioned for removal.

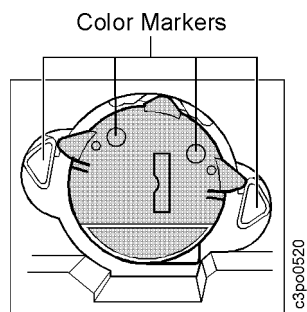

4. Make sure that the turret rotation knob is locked and that the color markers are fully visible. Pull the eject handle to release the toner cartridge.

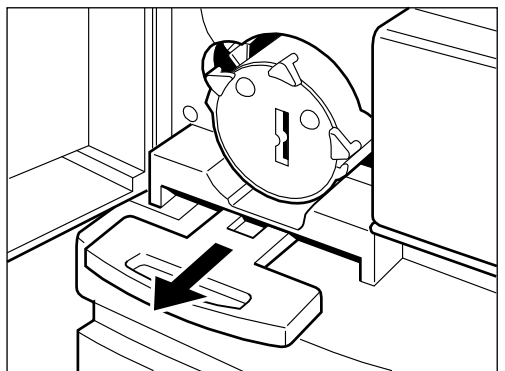

5. Slide the cartridge out.

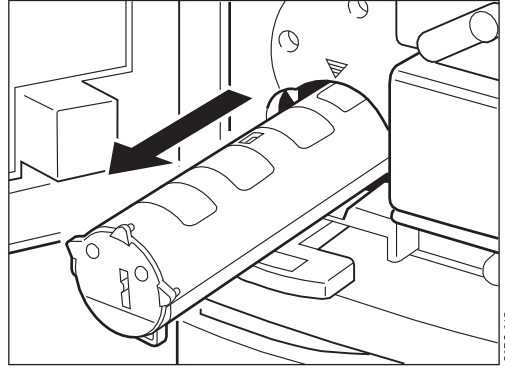

6. Hold the cartridge by the end with the opening seal to avoid getting your hands dirty and insert the cartridge into the protective bag that came with the new cartridge.

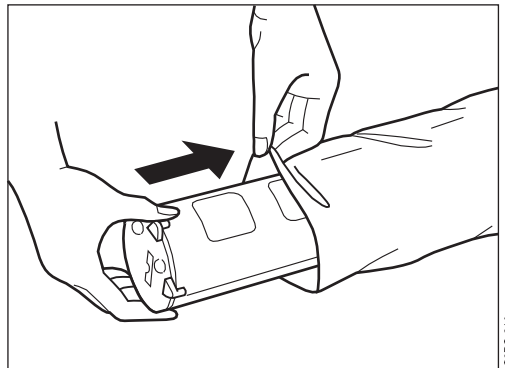

7. Dispose of the toner cartridge according to local regulations (see “Recycling the Used Toner Cartridge” on page 5–13). Do not shake the used cartridge. The toner might leak.

Installing a New Cartridge

Use the following procedure to install a new toner cartridge in the printer.

1. Find the turret rotation knob and the turret color markers in the illustration below.

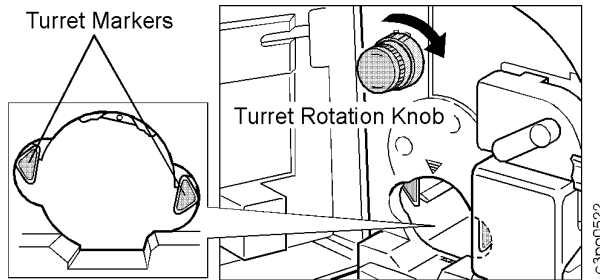

Because the printing process requires that the colors be applied in a specific order, the placement of each color toner cartridge in the turret is important. If you operate the printer with a toner cartridge inserted in the wrong order, you will damage the printer. The figure below shows the arrangement of the 4 color toner cartridges relative to each other in the turret.

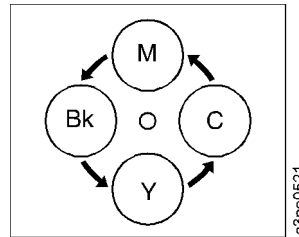

2. The figure below shows the correct alignment of a toner cartridge in the turret. When you insert a toner cartridge, make sure that the 2 color markers on the toner cartridge line up with the 2 markers on the turret.

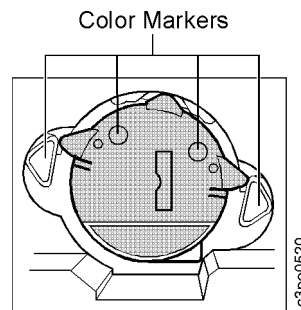

3. The turret rotation knob turns the turret so that you can insert the correct color toner cartridge. Before you insert a toner cartridge, turn the knob and notice the opening in the turret. Use the turret rotation knob as follows:
 - a. Push the knob in [1] and turn it clockwise about the distance between arrow [1] and arrow [2].
 - b. Release the knob [2].
 - c. Turn the knob clockwise [3]. Notice the rotation of the color markers in the turret opening.
 - d. When the turret is positioned to accept a cartridge, the knob moves outward [4] and locks. The color markers on the turret are fully visible.

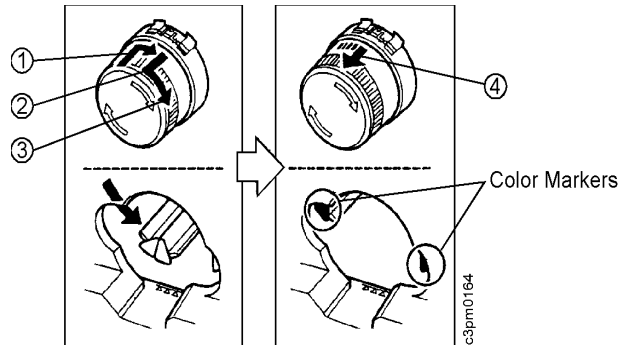

Attention:

When you handle a toner cartridge, do not touch the sensing window on the top and the bottom of the cartridge.

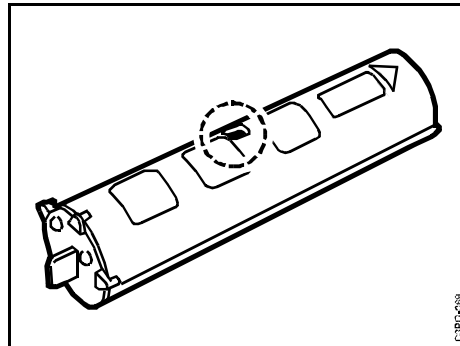

4. Remove a new toner cartridge from its protective bag.

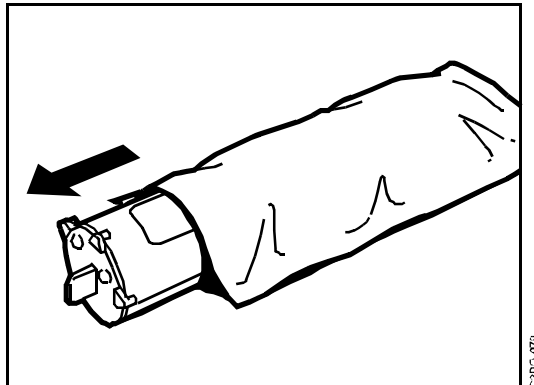

5. Hold the cartridge as shown below. Do not hold the cartridge so tightly that the tabs on the end of the cartridge contact your hand. Pressing the tabs can partially open the cover of the developing cylinder and damage the printer. Slowly move each end up and down five or six times to distribute the toner. (Do not do this with a used or an unsealed toner cartridge.)

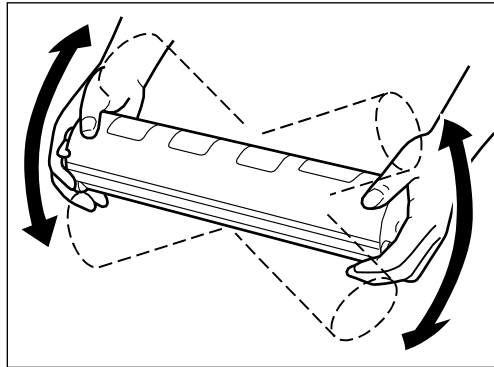

6. Remove the 2 protective tapes from the toner cartridge.

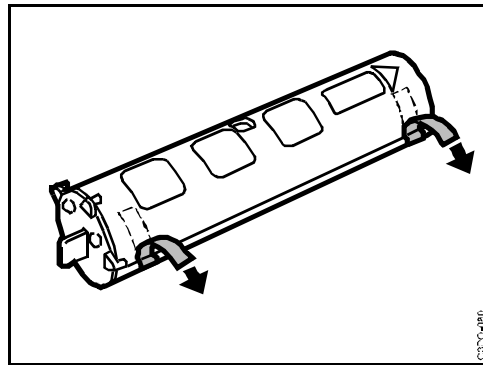

7. To remove the sealing tape, put the toner cartridge on a level surface. Hold the cartridge with one hand and slowly pull the orange tab out with the other hand. Pull the orange tab straight out to avoid breaking the tape.

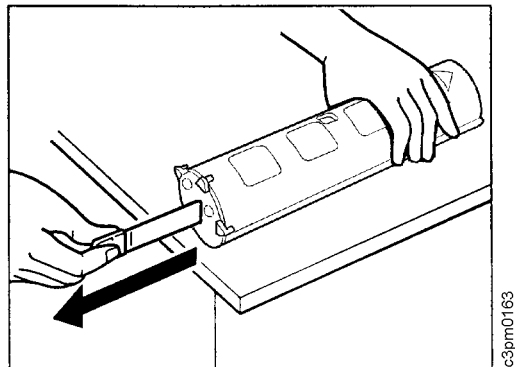

Attention:

Do not install a toner cartridge into the printer unless its developing cylinder cover is latched closed.

8. On the other end of the cartridge there is a small tab and an arrow [1]. Make sure that the tab [3] is fully seated in the notch [4]. Do one of the following:
 - If the tab is fully seated, go to step 9.
 - If the tab is not fully seated, hold the cartridge and use a pulling motion with your other hand to rotate the developing cover in the direction of the arrow [2]. The tab [3] must be fully seated in the notch [4] before you install the toner cartridge.

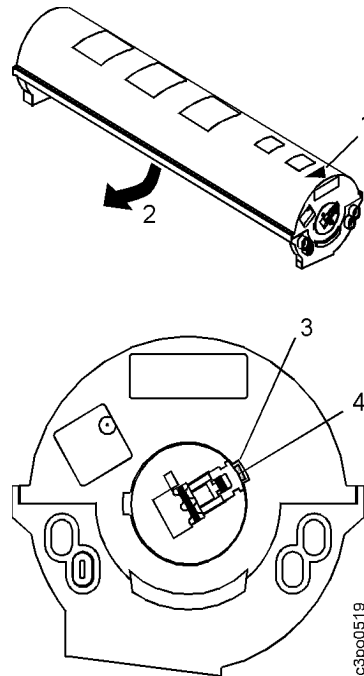

Attention:

Make sure that you insert the toner cartridge that matches the color markers in the turret opening.

9. Hold the toner cartridge with the arrow [2] up and pointing toward the printer. Using the arrow [1] on the printer's frame as a guide, slide the toner cartridge into the printer until it locks in place. You may have to push firmly on the cartridge to lock it into place.

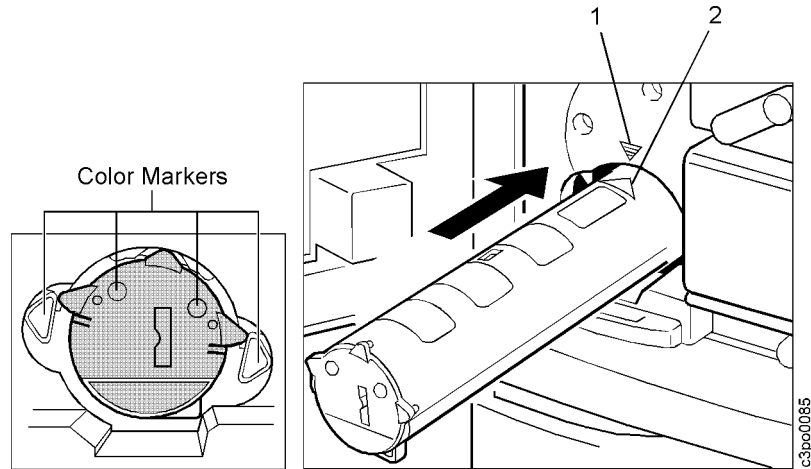

10. When the toner cartridge is locked in place, the surfaces [1] and [2] are even.

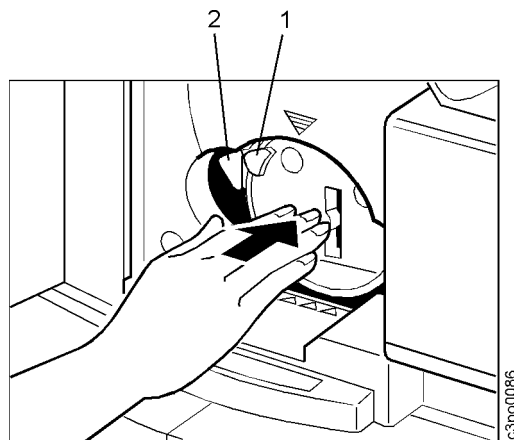

11. After you install the cartridge, turn the turret rotation knob to the next cartridge to make sure that the cartridge you just installed is correctly seated.
12. Close the front door.
13. Print a configuration page (see "Printing a Configuration Page" on page 4–9) and note the print count that it reports. Record this information on your Supplies Replacement Log, shown in Appendix B.

Recycling the Used Toner Cartridge

Use the following procedure to recycle the used toner cartridge.

1. Find the box that the new toner cartridge came in and the Clean Earth Campaign instruction sheet and shipping label provided inside the box.
2. Put the used toner cartridge in the foil bag that the new cartridge came in.
3. Put the used toner cartridge in the box that the new cartridge came in.
4. Seal the box.
5. Stick the pre-addressed shipping label on the box and ship the box according to the Clean Earth Campaign instruction sheet.

Replacing the Used Toner Bottle

This section tells you how to replace the used toner bottle. When you see the REPLACE USED TONER BOTTLE message on the display panel, use the following procedure to replace the used toner bottle.

1. Open the front door.

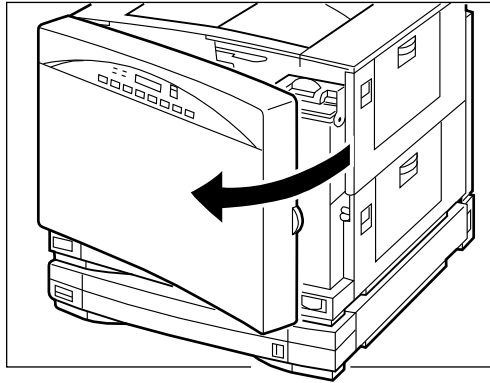

c39p0233

2. Push down on the release handle.

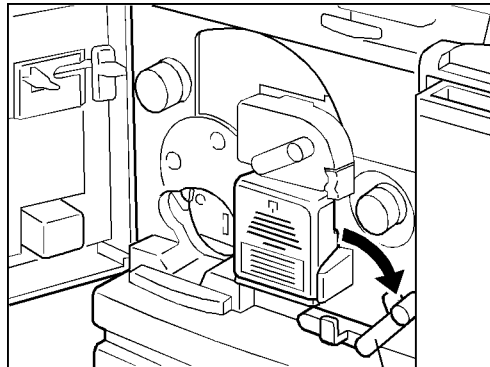

c39m0195

Release Handle

3. Open the photoconductor drum cover.

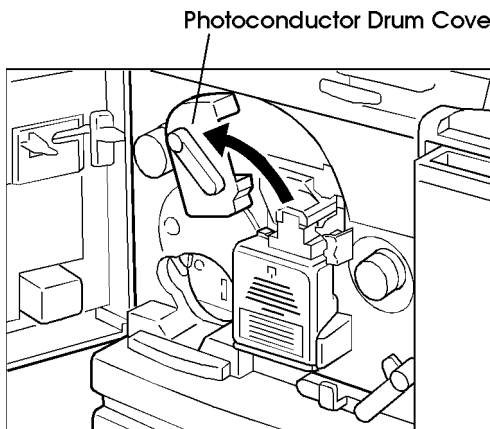

Photoconductor Drum Cover

c39m0196

4. Remove the used toner bottle.

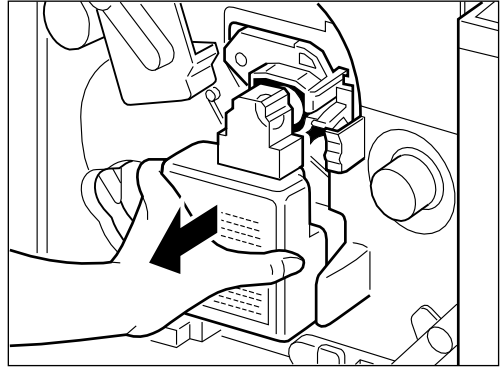

5. Seal the used toner bottle.

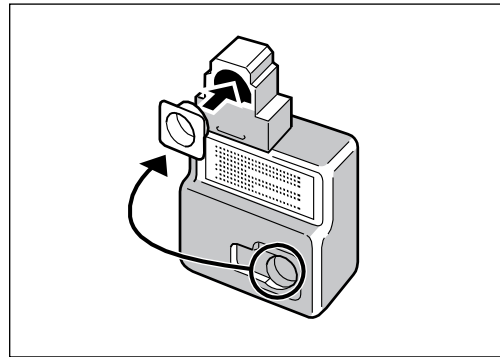

6. With the opening in the bottle facing the printer, attach the new used toner bottle [1] to the photoconductor drum cartridge.
7. Lower the photoconductor drum cover [2] to the closed position.
8. Raise the release handle [3] to the operating position.

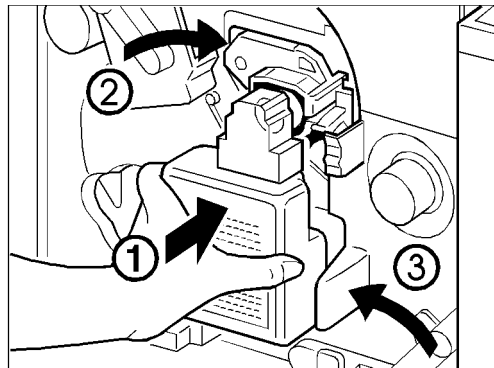

9. Close the front door.



<2-13> CAUTION:

Do not dispose of toner or toner containers in fire. Dispose of these in accordance with local regulations.

Replacing the Fuser Oil Bottle

This section tells you how to replace the fuser oil bottle. Fuser oil is used in the final stage of the printing process. When the oil level is low or when you see the FUSER OIL LOW message on the display panel, replace the fuser oil bottle with a new one using the instructions that follow.



<2-4> CAUTION:

If spilled, fuser oil causes hazardous surfaces; prevent anyone from entering the area until the surface is clean.

Attention:

Do not use the printer without a fuser oil bottle installed. If you do, you may damage the printer.

Removing the Old Fuser Oil Bottle

Use the following procedure to remove the old fuser oil bottle.

1. Open the front door.

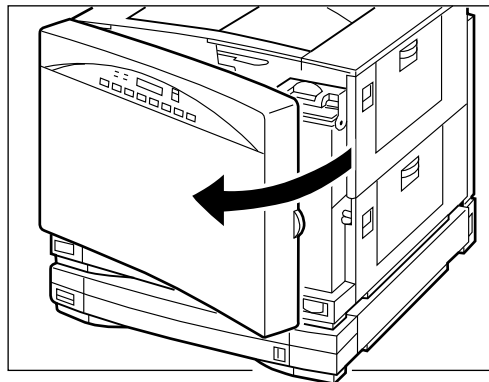

C31P0-226

2. Lower the fuser oil bottle cover [1]. Lift the oil bottle [2] from the oil bottle holder and put a towel under the bottle to prevent drops of oil from spilling on the floor.

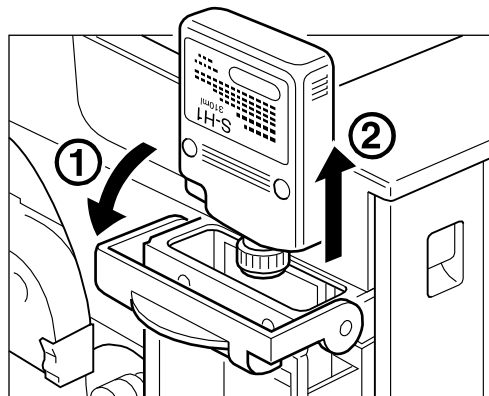

C31P0-227

Installing the New Fuser Oil Bottle

Use the following procedure to install the new fuser oil bottle.

Attention:

Do not shake the fuser oil bottle. Oil can spill out.

1. Peel off the seal from the new fuser oil bottle.

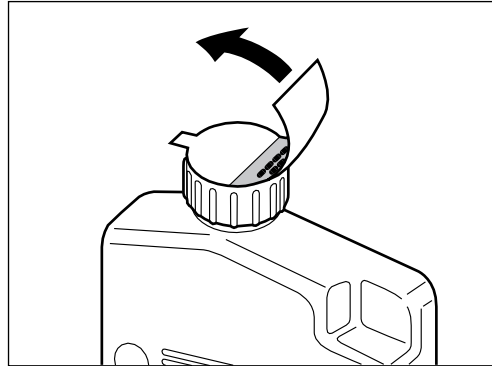

2. Turn the oil bottle upside down. Hold the oil bottle with its label facing out and put the bottle in the oil bottle holder.

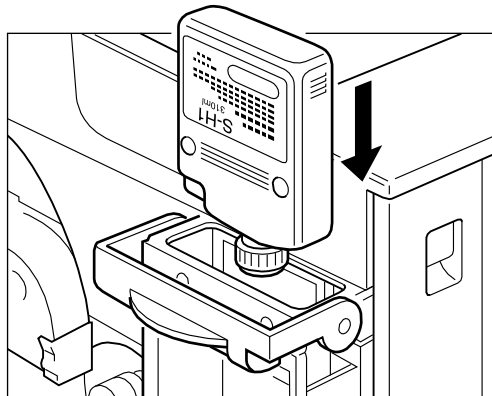

3. Align the bottle with the bottle holder. Firmly push down [1] on the bottle until it locks into place.
4. Raise the fuser oil bottle cover [2].

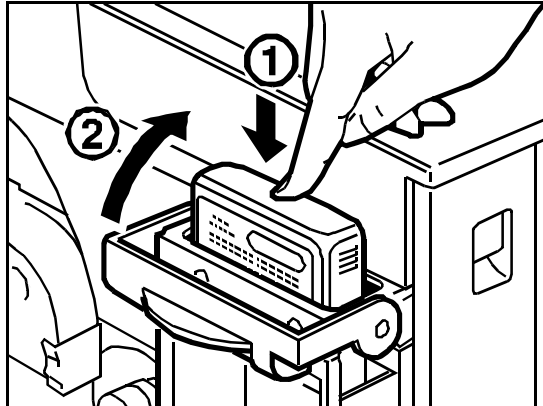

5. Close the front door.
6. Print a configuration page (see “Printing a Configuration Page” on page 4–9) and note the print count that it reports. Record this information on your Supplies Replacement Log, shown in Appendix B.

Replacing the Fuser

This section shows you how to

- Prepare the fuser and work area before beginning
- Remove the unused oil from the printer oil bottle holder (fuser oil-supply)
- Remove the used fuser
- Install a new fuser
- Return the unused oil and add a new bottle of oil to the printer

You do not replace the fuser often. It is designed to fuse approximately 60 000 prints, depending on your application. You can print a configuration page (see “Printing a Configuration Page” on page 4–9) to see the print count.



<2-9> CAUTION:

This printer may contain materials, either components or consumable supplies, that are regulated for disposal. Dispose of all items in accordance with local regulations.

Preparing the Fuser and Work Area

Use the following procedure to prepare the fuser and the work area before starting to replace the fuser.

1. Turn off the printer. This allows the printer to cool down.

OFF

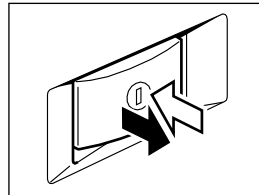

2. Check that you have the following items before you replace the fuser:
 - Oil removal tool (shipped with the printer)
 - Oil recycle bottle (shipped with the printer)
 - Flat-blade screwdriver
 - Absorbent towels

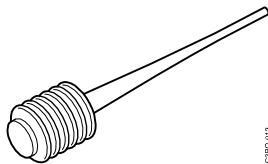

c3po012

Oil Removal Tool

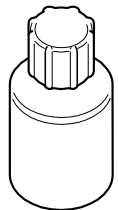

c3po013

Oil Recycle Bottle

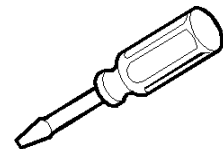

c3po0500

Screwdriver

3. Choose a level work area on which to put the used fuser, the new fuser, and the fuser oil. Put absorbent towels under the front of the printer and on the work area in case a few drops of fuser oil spill. Keep towels available in case you need to clean your tools.
4. Make sure that the printer is stable. If the printer is on the printer stand, make sure that the casters underneath the stand are locked.

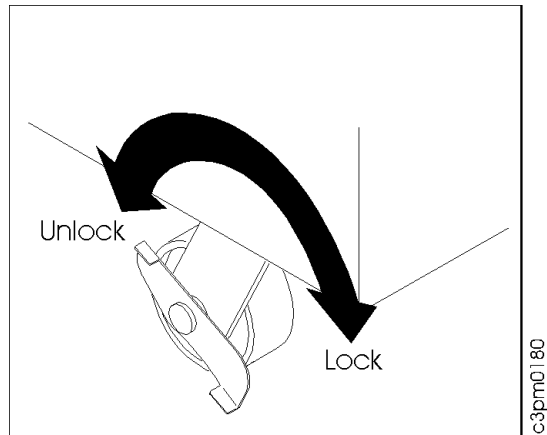

Unpacking the New Fuser

Use the following procedure to unpack the new fuser from the shipping box.

1. Open the top of the box.
2. Remove the 2 top foam shipping blocks.
3. Use the green hand holds to remove the fuser from the box. Put the fuser on the absorbent towels in the work area.
4. Save the box so that it can be used for disposal of the old fuser.

Removing the Fuser Oil from the Printer

Use the following procedure to remove the fuser oil from the printer.



<2-6> CAUTION:

High temperature; Switch off printer power and allow at least 15 minutes for parts in this area to cool before handling.

1. Open the fuser access door on the upper right side of the printer.

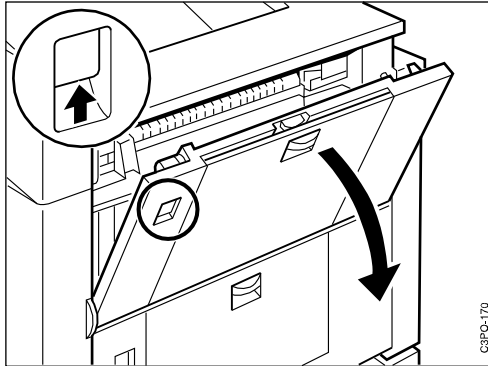

<2-4> CAUTION:

If spilled, fuser oil causes hazardous surfaces. Prevent anyone from entering the area until the surface is clean.

2. Lower the fuser oil bottle cover [1]. Lift the oil bottle [2] from the oil bottle holder and put a towel under the bottle to prevent drops of oil from spilling on the floor.

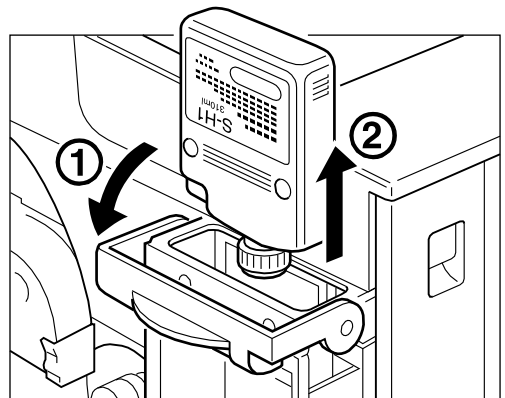

Attention:

Do not put the fuser oil bottle or the oil recycle bottle on top of the printer while recycling oil.

3. Wipe off any excess oil on the bottle and put the bottle upright in a safe place in the work area.

4. Open the oil recycle bottle and remove the inner seal.

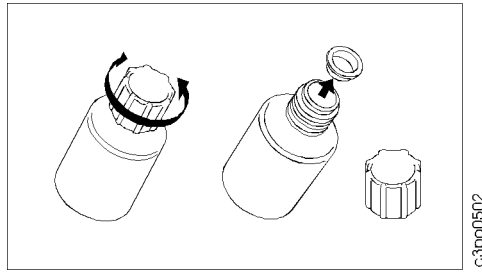

5. Put the oil recycle bottle on a towel on a level surface near the printer.
6. Use the oil removal tool to remove the fuser oil from the oil bottle holder as follows:
 - a. Push the top of the oil removal tool all the way down. Insert the pointed end of the oil removal tool into the oil supply in the oil bottle holder. Release the pressure on the oil removal tool and allow the oil to flow into it.

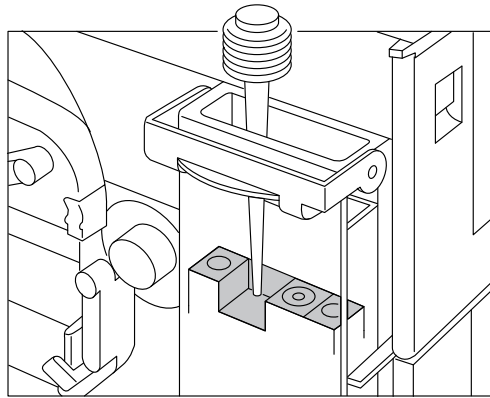

- b. Be careful not to spill any oil. Take the oil removal tool out of the oil bottle holder and insert the pointed end of the tool into the oil recycle bottle. Push the top of the tool down and force the oil into the recycle bottle.

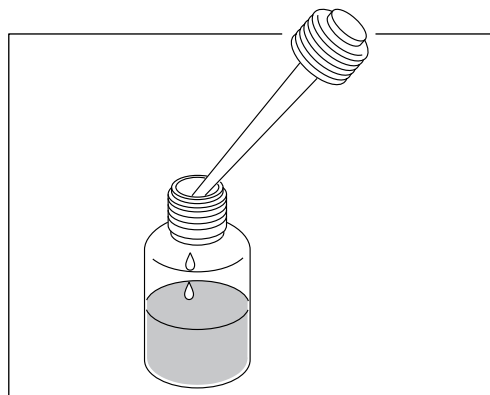

- c. Repeat step a and step b until you have removed most of the oil from the oil bottle holder.

7. Use the fuser jam-release lever to pump the remaining oil from the fuser into the oil bottle holder. You will need to pump the lever approximately 50 times.

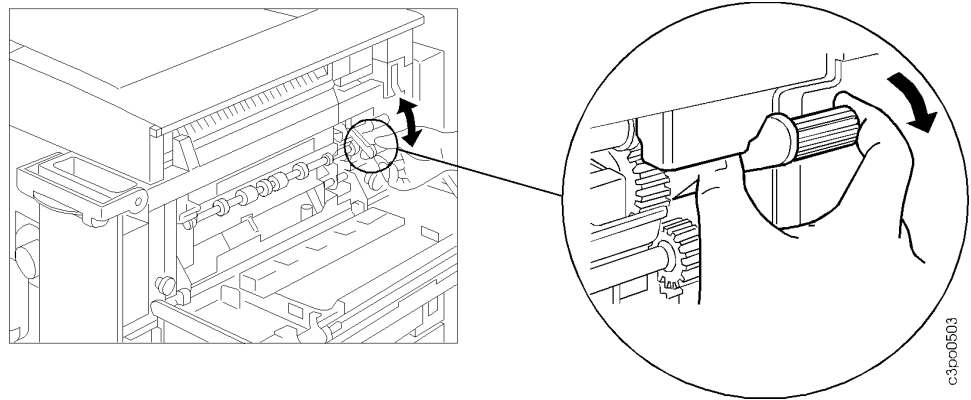

8. Repeat step 6 and step 7 three or four times until you have removed most of the oil from the fuser.

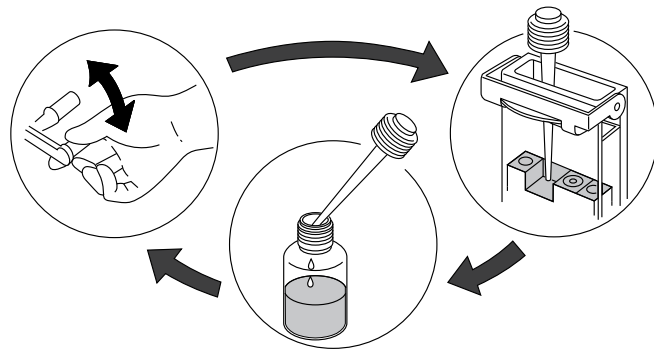

9. Replace the inner seal (see page 5–22) on the oil recycle bottle and cap the bottle.
10. Clean the oil removal tool with a towel and store it in the box in which it was shipped.

Removing the Fuser Access Door

Use the following procedure to remove the fuser access door from the printer.

Attention:

When you release the fuser access door strap, the door is free to swing down and may fall to the floor. Hold the door when you release the door strap.

1. Open the feeder access door on the lower right side of the printer.

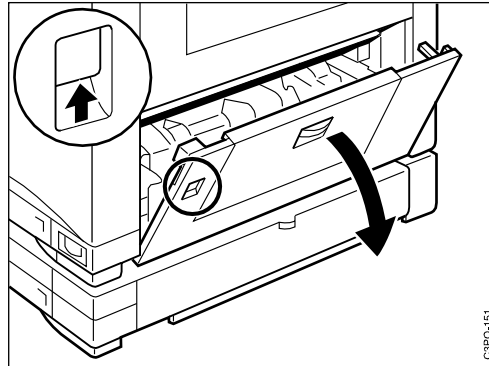

2. The strap of the fuser access door is attached to the upper locking tab on the printer frame. Release the strap this way:
 - a. Push the upper locking tab down [1].
 - b. Pull the tab out of the printer frame [2].
 - c. Lift the tab up and out of the printer frame [3].

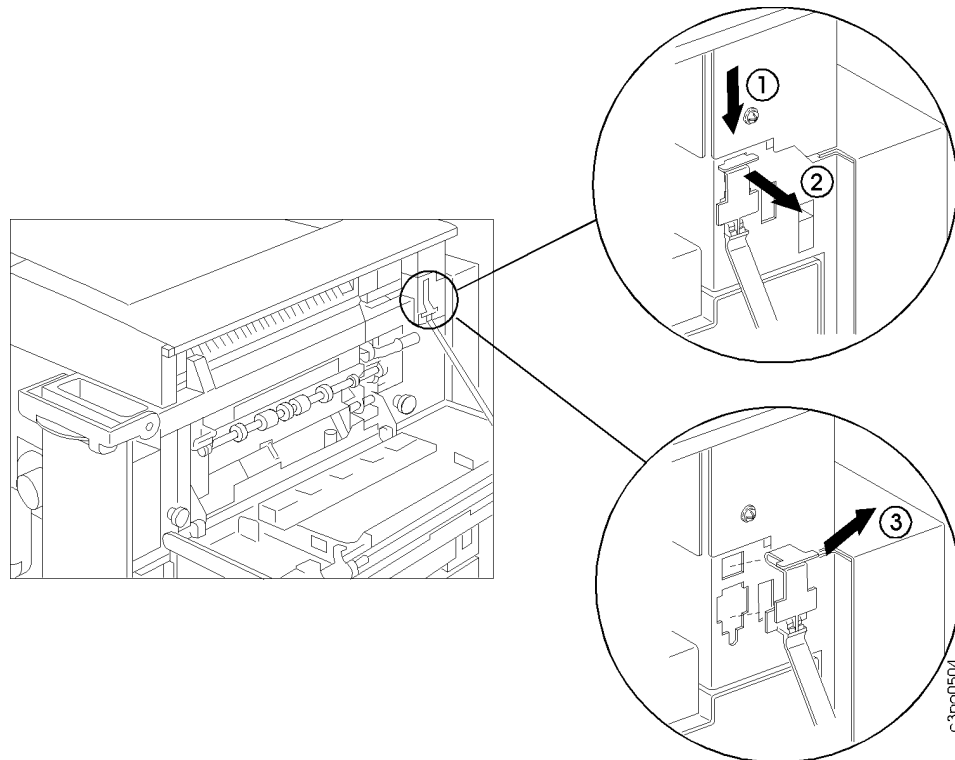

3. Slide the fuser access door to the left and rotate it down until the tab on the right pivot aligns with the cutout in the right bracket [1]. Slide the door to the left again and out of the brackets.

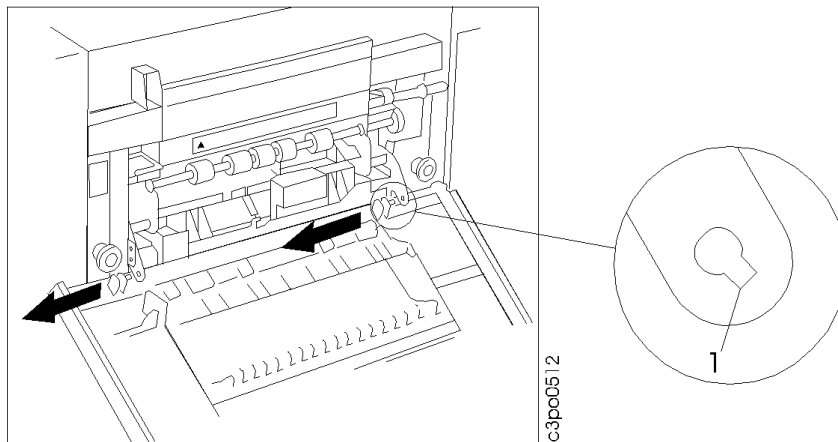

Removing the Used Fuser

Use the following procedure to remove the used fuser from the printer.

1. Loosen the 2 fuser screws that hold the fuser to the printer frame. These screws do not come out of the fuser. The fuser is not yet free. It is held by the fuser slide plate.

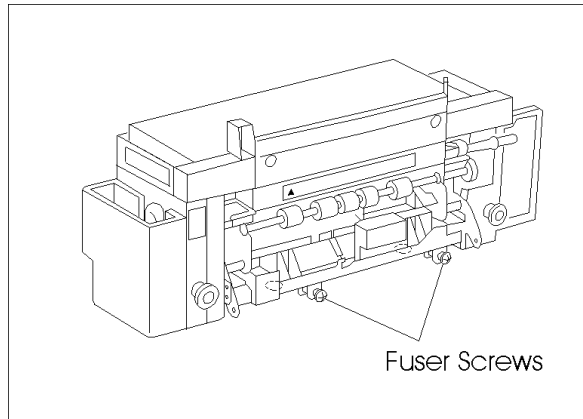

2. Use the 2 black pull knobs on the fuser to carefully pull the fuser and the fuser slide plate out approximately 25 cm (10 inches) until the fuser slide plate stops moving. The fuser slide plate continues to support the fuser.

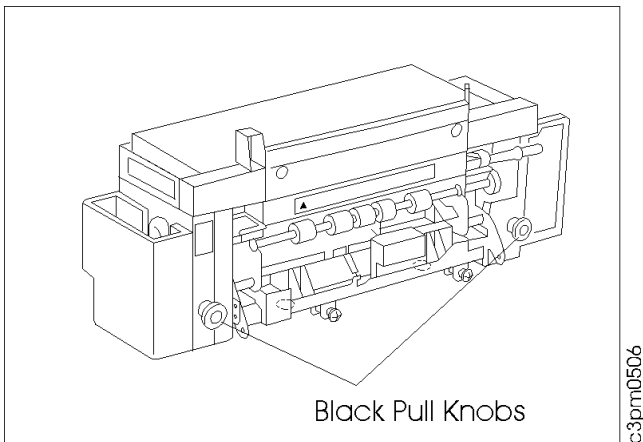

3. Use the green fuser handholds to remove the fuser from the printer and put it on the absorbent towels in the work area.

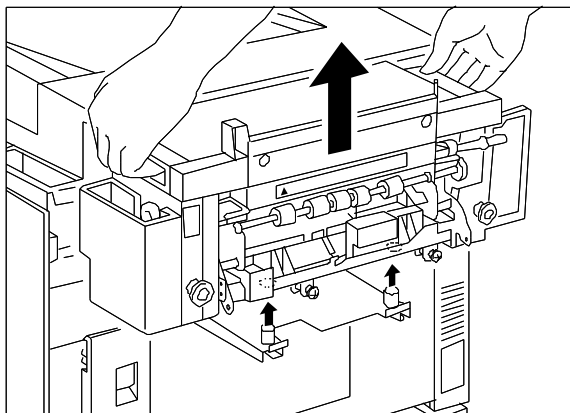

Installing the New Fuser

Use the following procedure to install the new fuser in the printer.

1. Use the green fuser handholds to put the new fuser on the sliding plate with the oil bottle holder positioned to the front of the printer. Position the 2 blue locating guides on the plate in the locating holes in the bottom of the fuser.

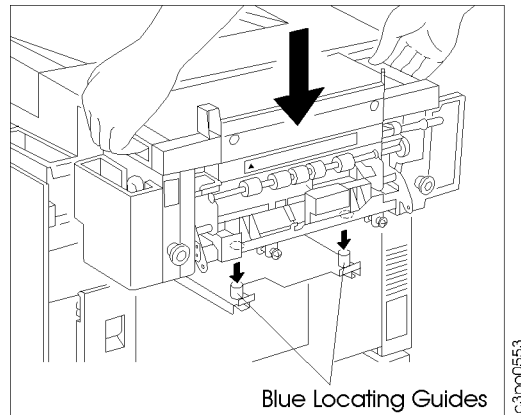

2. Use even pressure on the 2 black pull knobs (see step 2 on page 5–26) to slide the fuser firmly into place. Both slides on the fuser slide plate are positioned slightly inside of the printer frame when the fuser is pushed in against the stops.
3. Alternately tighten the 2 fuser screws, approximately 2 turns each, until they are tight.

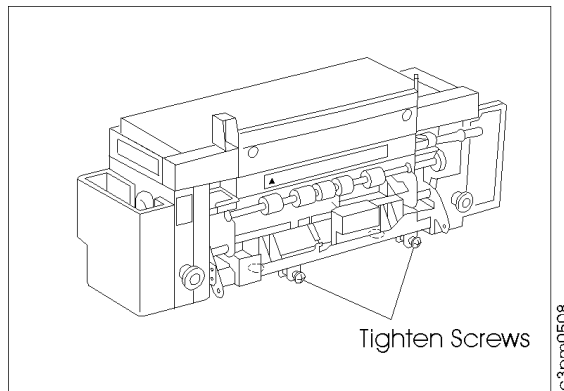

4. Pivot the orange shipping spacers up and pull them straight out of the fuser. Discard the shipping spacers.

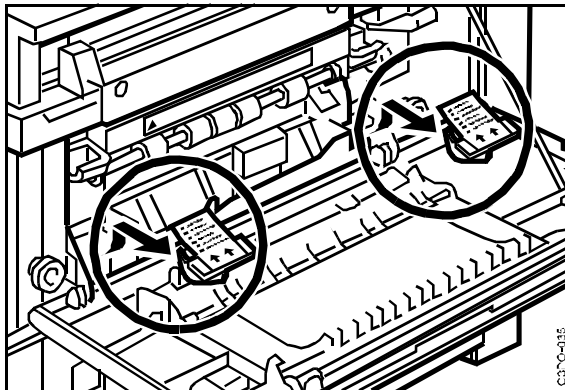

Replacing the Fuser Access Door

Use the following procedure to replace the fuser access door on the printer.

1. Make sure that the feeder access door is open.
2. Hold the fuser access door with the top edge pointing down and align the 2 pivots on the door with the 2 brackets on the frame (the door pivot on the right has a tab that aligns with the cutout [1] in the right bracket). Slide the door to the right and rotate it up.

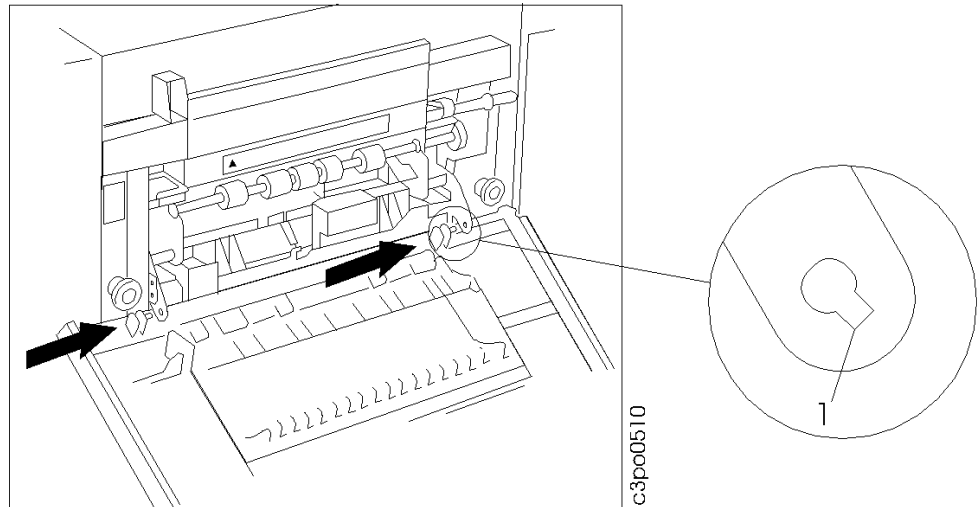

3. Grasp the tab at the top of the strap on the fuser access door [1]. Insert the tab into the cutout in the printer frame [2] and slide the tab down until the top of the tab [3] aligns with the hole in the frame [4]. Push the tab into the hole in the frame and lock it in place.

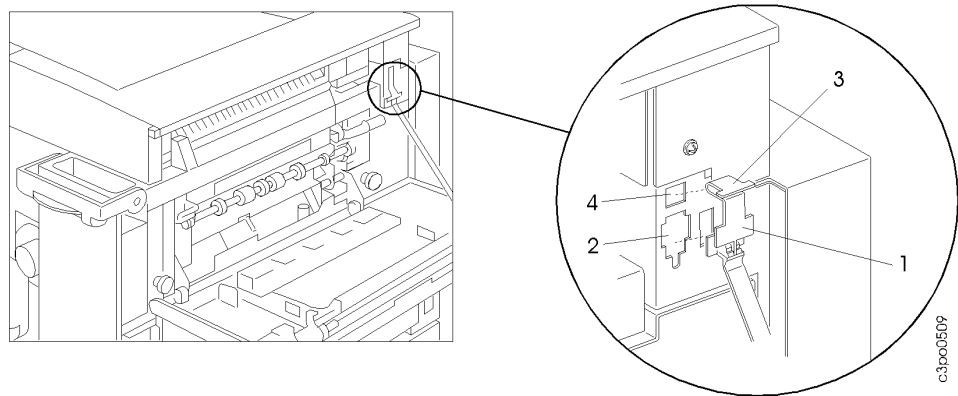

Filling the New Fuser Unit with Fuser Oil

Use the following procedure to fill the new fuser unit with fuser oil.



<2-4> CAUTION:

If spilled, fuser oil causes hazardous surfaces. Prevent anyone from entering the area until the surface is clean.

1. Open the oil recycle bottle and slowly pour the oil saved from the used fuser unit into the oil bottle holder of the new fuser unit.

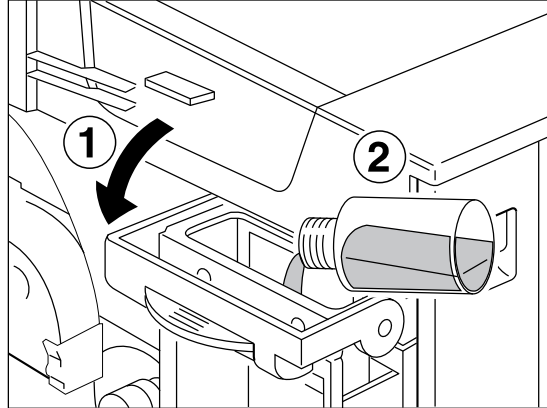

2. Replace the inner seal (see step 4 on page 5–22) and close the oil recycle bottle. Clean the bottle with a towel and store it in the box in which it was shipped.

Attention:

Do not shake the fuser oil bottle. Oil can spill out.

3. Lower the fuser oil bottle cover [1].
4. Hold a towel on the top of the oil bottle and turn the bottle upside down. Hold the oil bottle with its label [2] facing out and put the bottle in the oil bottle holder.

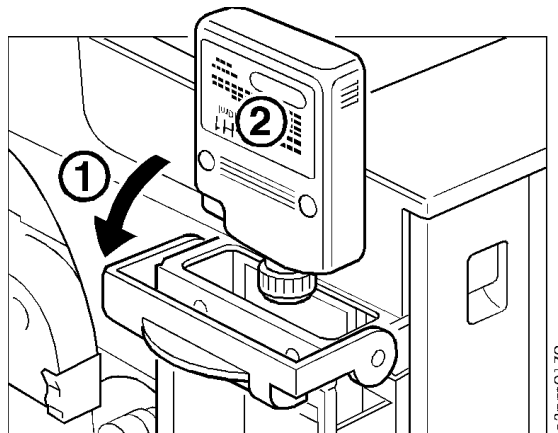

5. Align the bottle with the bottle holder. Firmly push down [1] on the bottle until it locks into place.

6. Raise the fuser oil bottle cover [2].

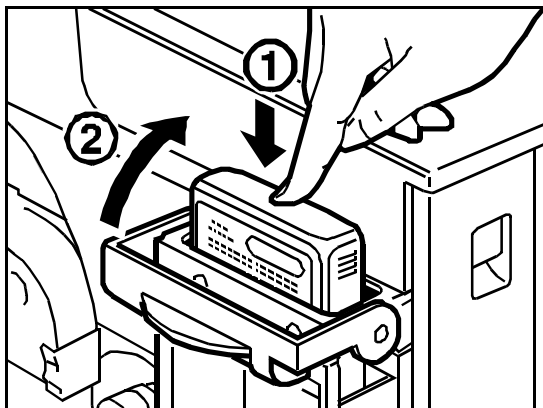

7. Close the fuser access door and the feeder access door.
8. Close the front door.

Printing Test Pages

Use the following procedure to print test pages to determine if you have correctly installed the new fuser.

1. Turn on the printer.

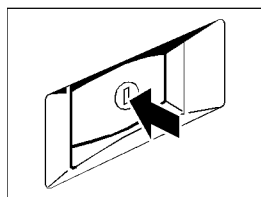

ON

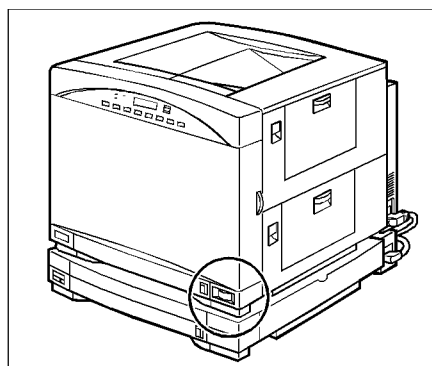

c3po0559

The printer fuser takes approximately 5 minutes to warm up if it is cold when you turn the printer on. While the printer is warming up, it runs a power-on self-test (POST). The POST checks to see if the printer is working correctly.

As the POST runs, you see status messages on the display panel. You do not have to read these messages unless the POST stops before the test is finished. Normally, the POST finishes without problems and you see the READY message on the display panel.

If the POST does stop before it is finished, the **Attention** light on the display panel flashes. Check the display panel for a message, an error code, or a blank display. See “Understanding POST Error Messages” on page 7–2 to find out what to do next.

2. Print several test pages as described in “Printing a Test Page” on page 4–10.
3. Check that the toner is completely fused onto the paper by gently rubbing the printout. If the toner smears or comes off, see “Correcting Print Quality Problems” on page 6–13.
4. Print a configuration page (see “Printing a Configuration Page” on page 4–9) and note the print count that it reports. Record this information on your Supplies Replacement Log, shown in Appendix B.

Replacing the Photoconductor Drum Cartridge

This section tells you how to replace the photoconductor drum cartridge and clean the separation corona wire. If you see black vertical streaks or toner spots on printouts, it is time to replace the photoconductor drum cartridge. If you see the REPLACE DRUM TO ENSURE QUALITY message on the display panel, replace the cartridge immediately, using the procedure below.

Note: When you replace the photoconductor drum cartridge, replace it with a *new* cartridge. The printer may not work correctly with a used photoconductor drum cartridge.

Locating the Orange Photoconductor Drum Shield

Before you begin this procedure, locate the orange photoconductor drum shield that protected the cartridge before the cartridge was installed in the printer. It is bright orange in color and shaped like a trough. You will need this photoconductor drum shield when you remove the drum cartridge.

Removing the Old Photoconductor Drum Cartridge

Use the following procedure to remove the old photoconductor drum cartridge from the printer.

1. Make sure the power switch is turned off. Open the front door.

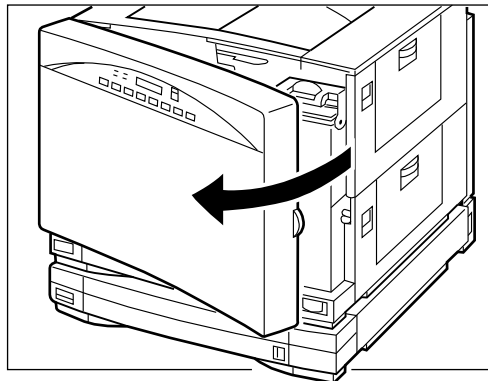

2. Push down on the release handle.

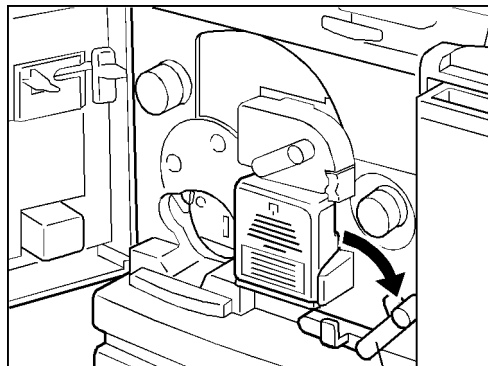

Release Handle

3. Open the photoconductor drum cover.

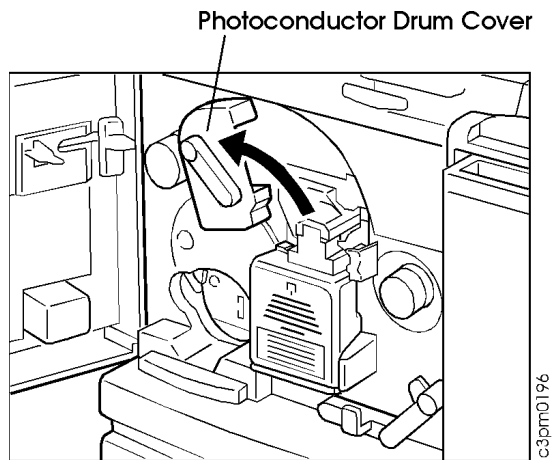

4. Remove the used toner bottle.

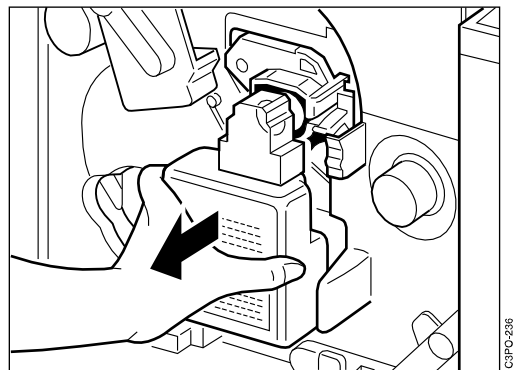

Attention:

Do not remove the used toner from the toner bottle or reuse it.

5. Seal the used toner bottle and put it aside.

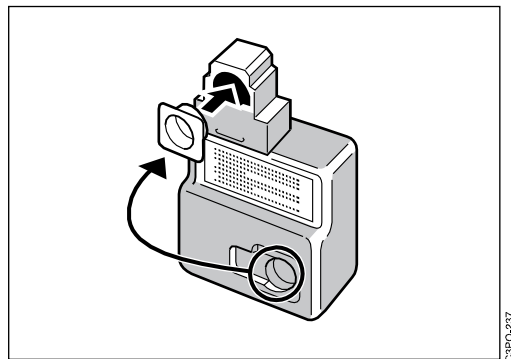

6. Put the V-shaped end of the orange photoconductor drum shield in the V-shaped support.

7. Press the green tab [1] on the right side of the photoconductor drum cartridge and pull the drum cartridge out [2] of the printer onto the shield.

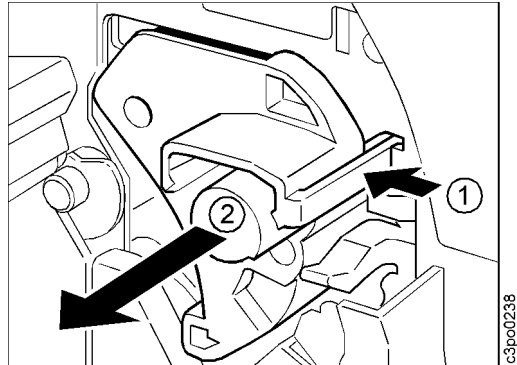

Installing a New Photoconductor Drum Cartridge

Use the following procedure to install a new photoconductor drum cartridge in the printer.

1. Get a new photoconductor drum cartridge and remove it from the protective bag.

Notes:

- 1) Do not open the protective bag or the photoconductor drum cartridge cover until you are ready to install the cartridge in the printer.
- 2) Do not expose the photoconductor drum cartridge to or store it in direct sunlight.
- 3) Do not remove the orange protective shield from the cartridge until you are instructed to do so.

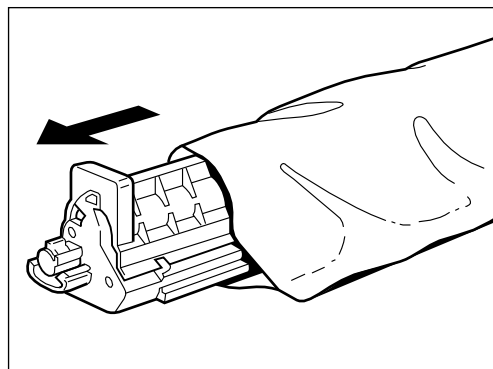

2. Use the arrow on the cartridge as a guide to align the photoconductor drum cartridge with the arrow on the printer. The orange photoconductor drum shield rests on a V-shaped cutout on the printer.

Do not use excessive force on the shield when you handle the photoconductor drum cartridge. If you do, you may scratch the

photoconductor drum.

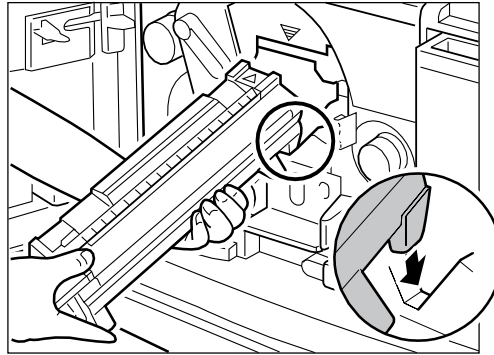

3. Hold the orange shield with one hand. Slowly slide the cartridge from the orange shield and into the printer with the other hand until the tab on the cartridge locks in place. Keep the orange shield for use later when you remove the photoconductor drum cartridge.

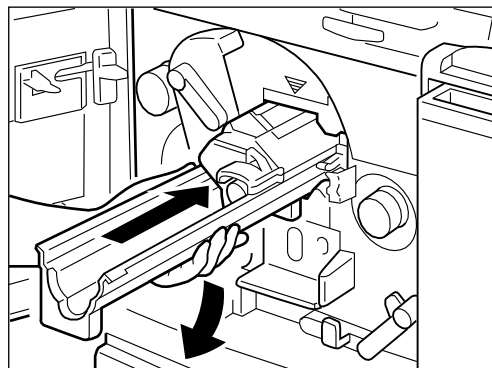
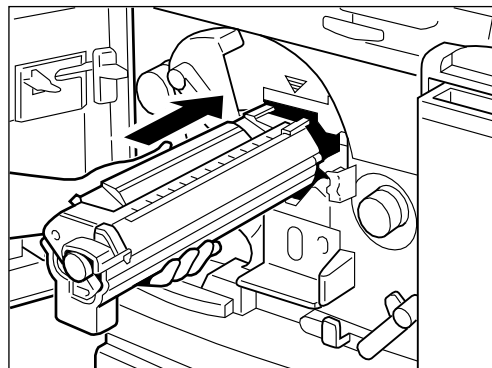
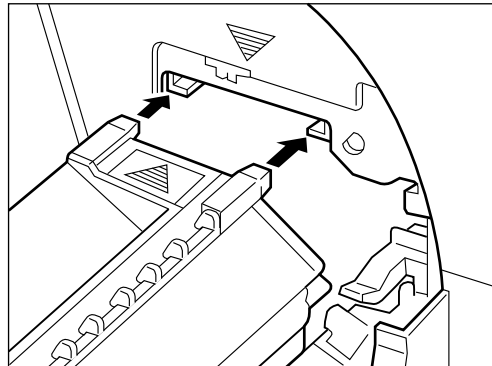

4. Push the cartridge all the way in until the green tab on the end is locked.

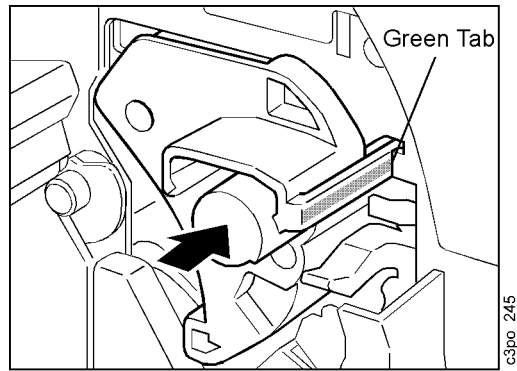

5. With the opening in the bottle facing the printer, attach the new used toner bottle to the photoconductor drum cartridge.

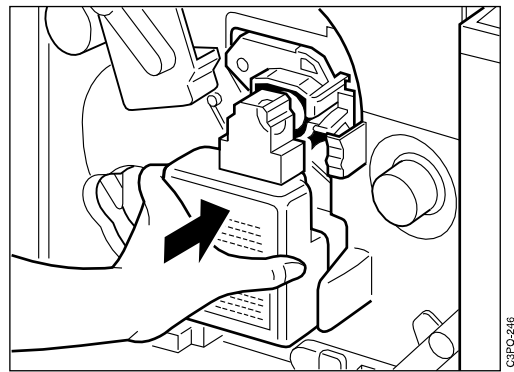

6. Lower the photoconductor drum cover to the closed position.

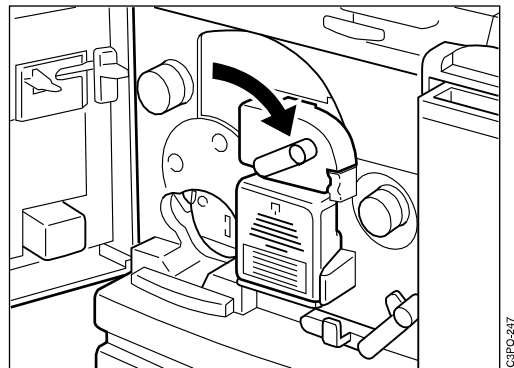

Attention:

If you cannot push up the release handle completely, do not force it up or you may damage the printer. Instead, remove the cartridge and reinstall it. Make sure that the cartridge is completely inside the printer.

7. Raise the release handle to the operating position.

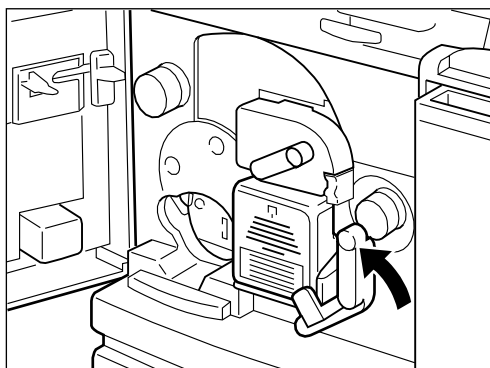

Recycling the Photoconductor Drum Cartridge

Use the following procedure to recycle the used photoconductor drum cartridge.

1. Find the box that the new photoconductor drum cartridge came in and the Clean Earth Campaign instruction sheet and shipping label that were inside the box.
2. Put the used photoconductor drum cartridge in the foil bag that the new cartridge came in.
3. Put the used photoconductor drum cartridge in the box that the new cartridge came in.
4. Seal the box.
5. Stick the pre-addressed shipping label on the box and ship the box according to the Clean Earth Campaign instruction sheet.

Cleaning the Separation Corona Wire

When you replace a photoconductor drum cartridge, you should also clean the separation corona wire. Use the following procedure to clean the separation corona wire.

1. Open the top cover to see the separation corona unit and the wire cleaner.

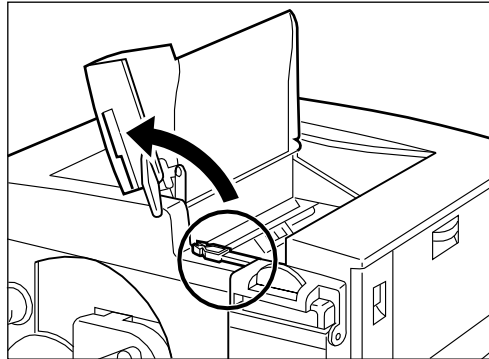

2. Remove the wire cleaner from inside the printer. The separation corona wire is very thin and delicate, so be careful not to break it.

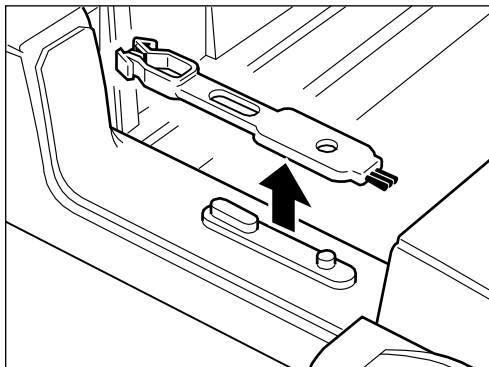

3. Put the padded end of the wire cleaner on the separation corona unit.

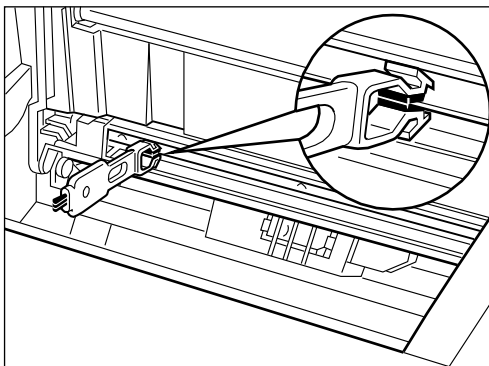

4. Clean the separation corona wire by moving the wire cleaner from side to side several times.

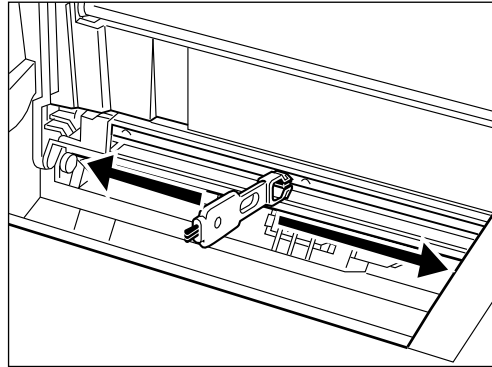

5. After you clean the wire, put the wire cleaner back in its storage place and close the top cover.

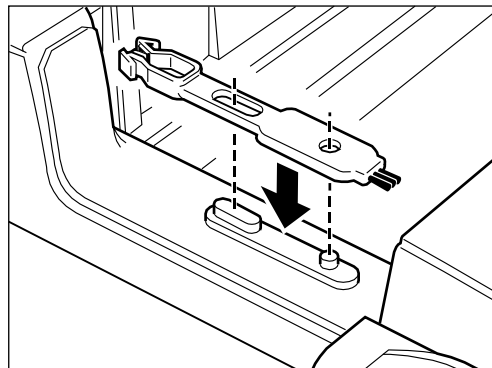

6. Close the front door.
7. Print a configuration page (see "Printing a Configuration Page" on page 4–9) and note the print count that it reports. Record this information on your Supplies Replacement Log, shown in Appendix B.

You have finished replacing the photoconductor drum cartridge and the used toner bottle and cleaning the separation corona wire. Turn on the printer again.

Chapter 6. Diagnosing Printer Problems

This chapter helps you diagnose problems you may have when using the printer. It tells you how to clear paper jams and correct the quality of the printouts. This chapter also explains how to adjust the left margin of tray 2 and the color density of the printouts and how to set the separation corona mode.

This chapter covers the following topics:

Common Printer Problems	6-2
Clearing Paper Jams	6-3
Clearing a Paper Jam in Area 1 (Transfer Drum Area)	6-4
Clearing a Paper Jam in Area 2 (Fuser Area)	6-6
Clearing a Paper Jam in Area 3 (Paper Feeder Area)	6-9
Clearing a Paper Jam in the Tray 2 Paper Feeder	6-12
Correcting Print Quality Problems	6-13
Adjusting the Side Registration on Tray 2 Printouts	6-20
Adjusting the Color Density	6-22
Printing Test Prints from the Density Control Panel	6-24
Setting the Separation Corona Mode	6-26

Common Printer Problems

This section lists common problems you may have with the printer and suggests ways to correct each problem. If the problem persists, contact your authorized service dealer or IBM service representative.

This table lists some common printer problems, the possible cause of each problem, and a recommended action to fix each problem.

Common Printer Problems		
Problem	Possible Cause	Action
The printer does not turn on.	Is the power cord securely plugged into the AC outlet?	Check the power cord connection.
	Is the printer turned on?	Make sure the power switch is turned on.
The print quality is poor.	Are you using the correct paper?	Check the paper (see "Choosing Paper" on page 2-2).
	Is the printer periodically cleaned?	Clean the printer (see "Cleaning the Outside of the Printer" on page 8-2).
The front door does not close.	Are the following set to their operating positions? <ul style="list-style-type: none"> • top cover • fuser oil bottle cover • photoconductor drum cover • transfer drum release handle 	See the following to determine what might be preventing the door from closing: <ul style="list-style-type: none"> • "Replacing the Fuser Oil Bottle" on page 5-16 • "Replacing the Photoconductor Drum Cartridge" on page 5-33 • "Replacing Toner Cartridges" on page 5-4
Paper jams occur frequently.	Does the paper that is loaded go above the paper limit mark?	Make sure that each stack of paper does not go above the paper limit mark.
	Is the paper stack correctly aligned?	Make sure the paper stack is correctly aligned in tray 1, tray 2, and the auxiliary tray.
	Are you using the correct paper?	Check the paper (see "Choosing Paper" on page 2-2).
	Is there any jammed paper inside the printer?	Make sure no paper remains inside the printer after a paper jam (see "Clearing Paper Jams" on page 6-3).
Printouts do not go into the top output tray.	Is the side output tray closed?	Close the side output tray (see "Using the Side Output Tray" on page 3-13 and "Using the Top Output Tray" on page 3-15).

Clearing Paper Jams

This section tells you how to clear paper jams from the printer. What you see below is a copy of the label on the fuser oil bottle inside of the printer. The label shows the three possible places in the printer for paper jams: the transfer drum area, the fuser area, and the paper feeder area.

Area 1: Transfer Drum

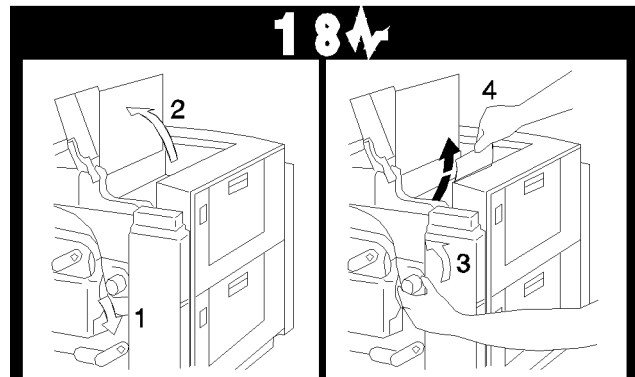

Area 2: Fuser

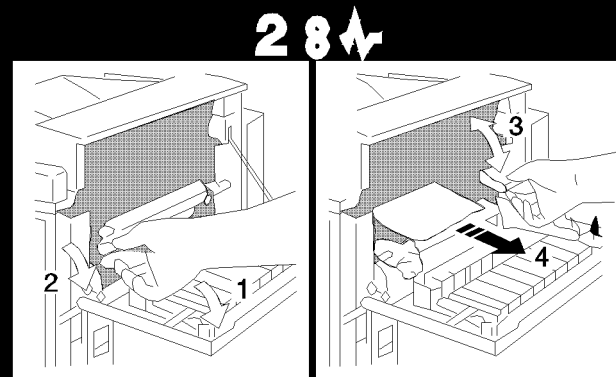

Area 3: Paper Feeder

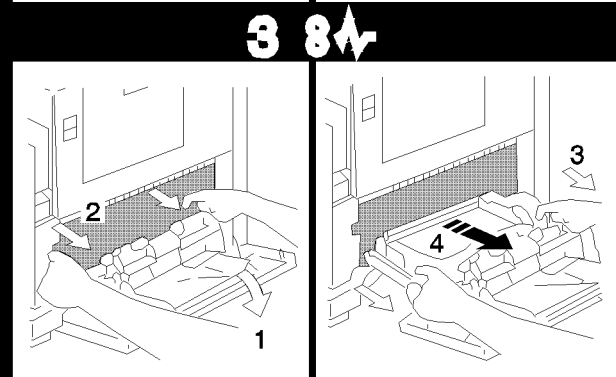

c3po0535

To clear a paper jam, use the procedures that follow. If you do not use the procedures, you may damage the printer.

Clearing a Paper Jam in Area 1 (Transfer Drum Area)

Use the following procedure to clear paper jammed in the transfer drum area of the printer.

1. Open the front door.

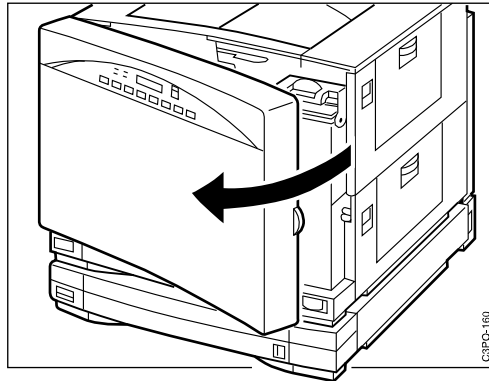

2. Open the top cover to see the transfer drum. Avoid touching the window of the density detection sensor.

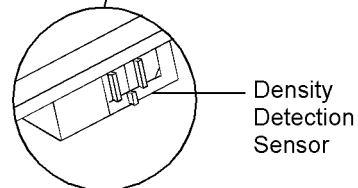
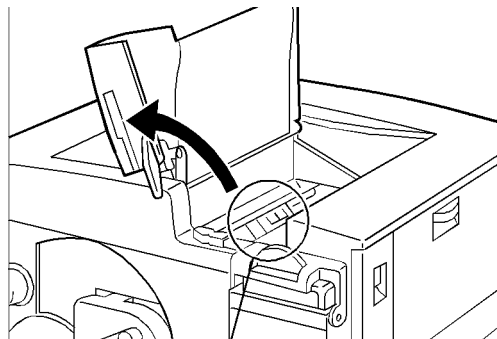

3. Push the release handle down to unlock the transfer drum.

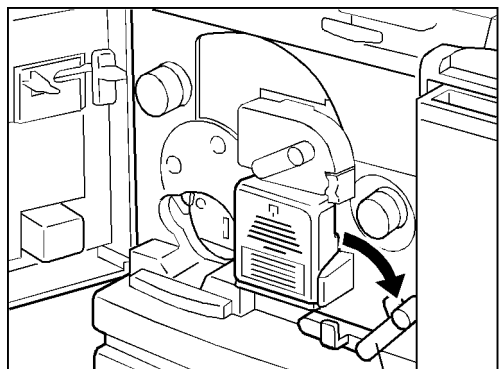

Release Handle

4. Turn the transfer drum knob counterclockwise [1] and gently pull out the jammed paper [2] at a slight angle [3]. Pulling at an angle will prevent your knocking any unused toner onto the density detection sensor.

Be careful not to touch the transfer drum when removing the jammed paper.

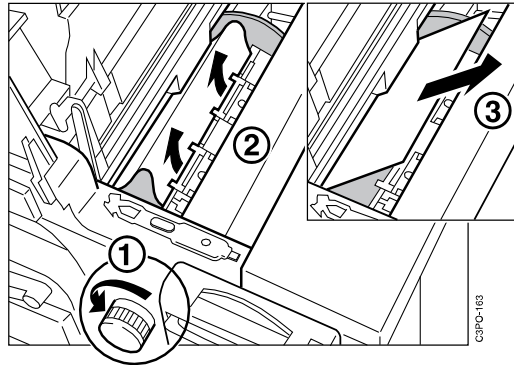

5. Close the top cover.
6. Push the release handle up to the operating position.

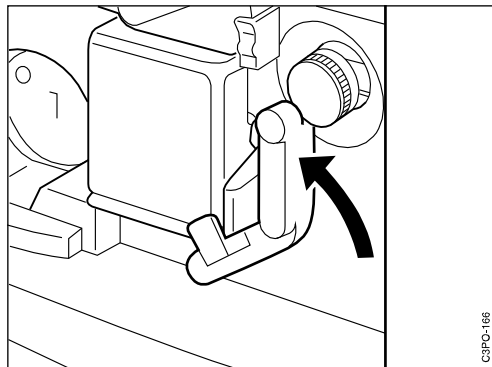

7. Close the front door.

Clearing a Paper Jam in Area 2 (Fuser Area)

Use the following procedure to remove jammed paper from the fuser area of the printer. The fuser area is on the right side of the printer behind the side output tray.

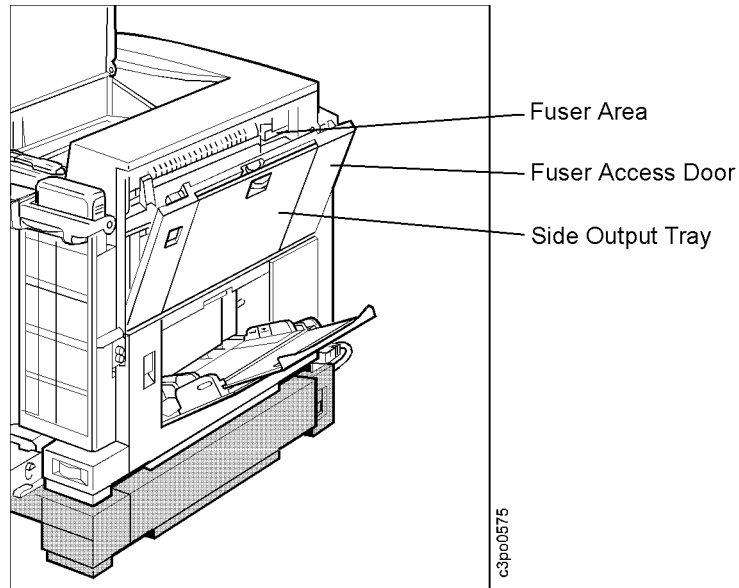

1. Close the side output tray if it is open.

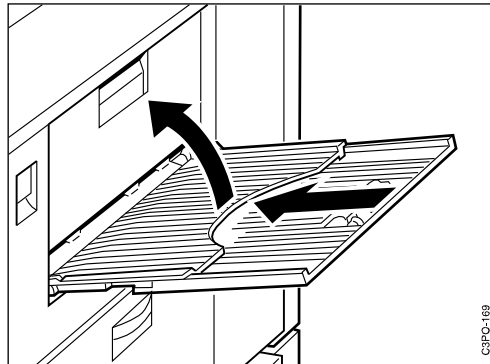

2. Push up the release latch to open the fuser access door.

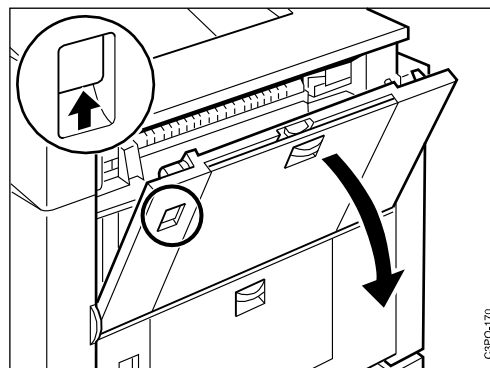

3. If the leading edge of the paper is visible, remove the jammed paper this way.



<2-11> CAUTION:

High temperature. Allow parts in this area to cool for about 2 minutes before you handle them.

- a. Pull the release knobs at both ends of the paper guide and open the paper guide cover.

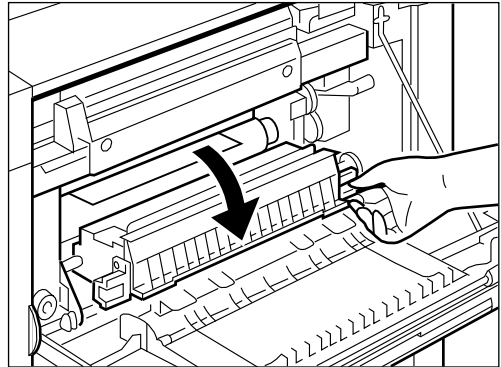

- b. Move the fuser jam-release lever up and down several times to eject the jammed paper. Do not simply pull the jammed paper out because it may tear and leave pieces of paper in the printer.

Note: Be sure to open the paper guide cover before you use the fuser jam-release lever.

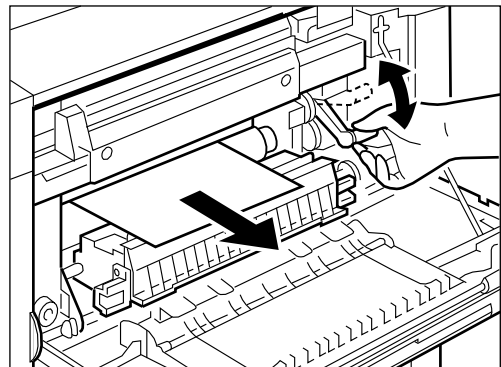

4. If the jammed paper is wound around the upper or lower fuser roller, remove the paper this way.
 - a. Open the paper guide cover [1] and move the fuser jam-release lever up and down [2] until the edge of the jammed paper is visible.

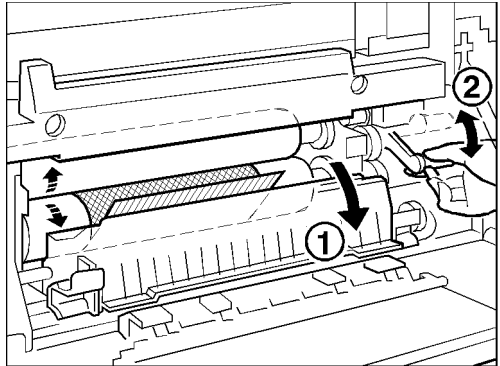

Paper Wound up on the Lower Roller

- b. Unlock the fuser rollers by moving the release lever toward the back of the printer and seating it in the slit on the metal plate.

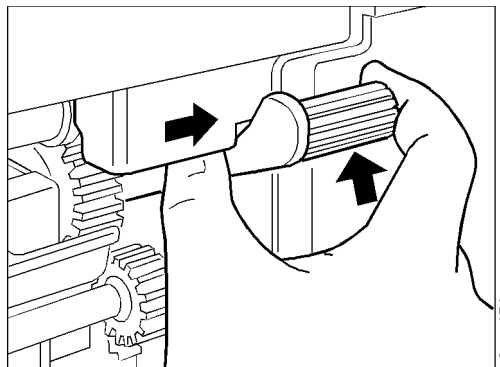

- c. Slowly pull the jammed paper out of the printer.

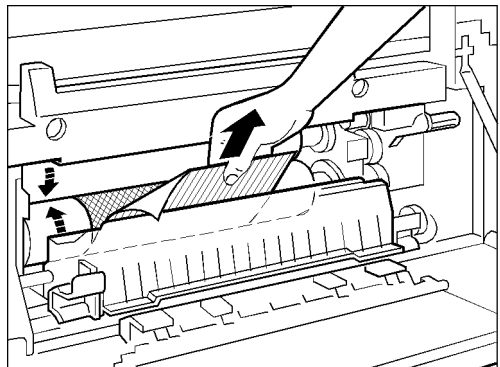

- d. Put the lever back to its original position and close the paper guide cover.

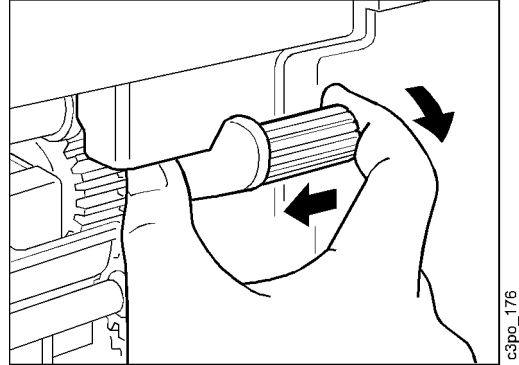

5. Close the fuser door.

Clearing a Paper Jam in Area 3 (Paper Feeder Area)

Use the following procedure to clear jammed paper from the paper feeder area of the printer. The paper feeder area is behind the feeder access door.

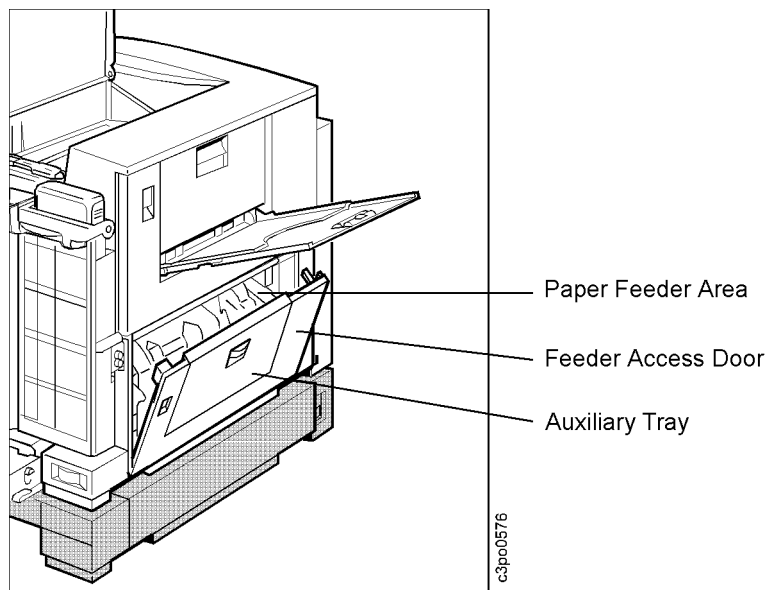

1. Make sure the auxiliary tray is closed.

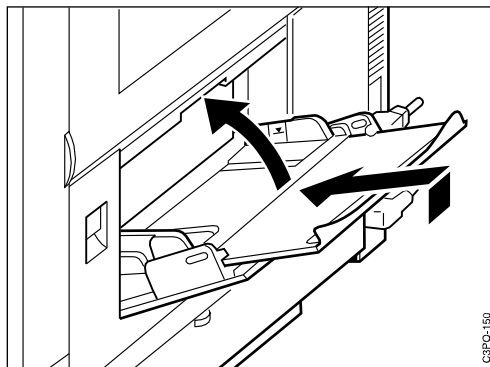

2. Push up the release latch to open the feeder access door.

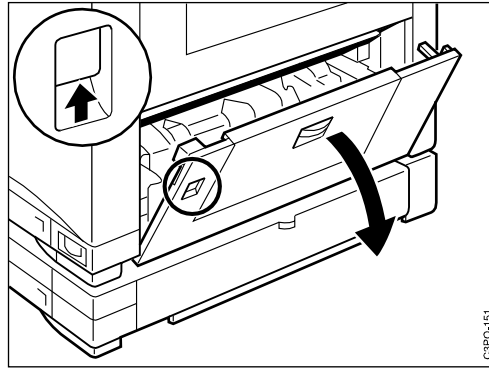

3. Remove any jammed paper.

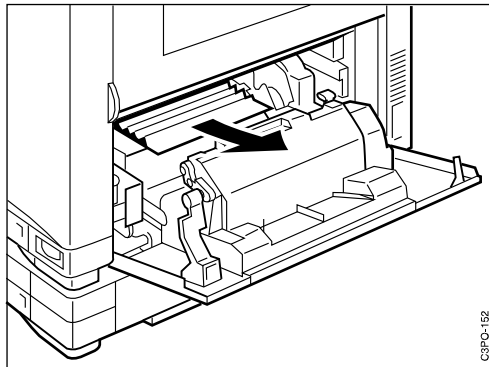

4. If the jammed paper is not visible or if it is hard to remove, pull on the 2 green levers to slide out the paper feeder.

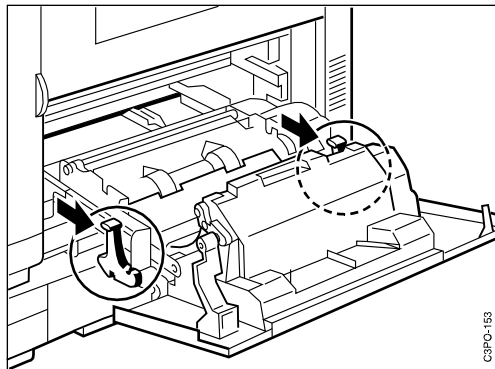

5. Carefully remove the jammed paper from the likely spots as indicated.

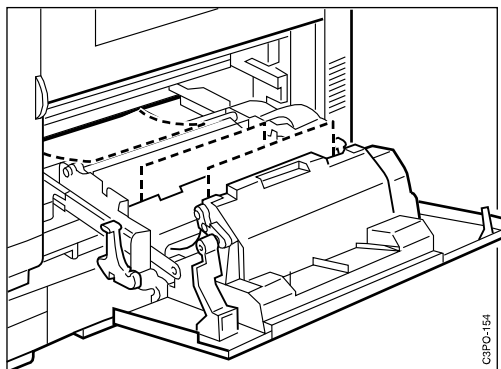

6. Slide the paper feeder back into the printer.

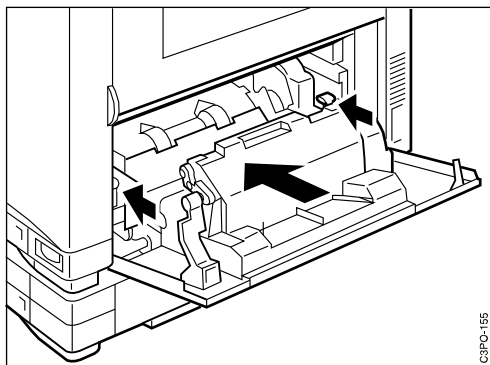

7. Close the feeder access door.

Clearing a Paper Jam in the Tray 2 Paper Feeder

If the printer has a tray 2 paper feeder, use the following procedure to clear jammed paper.

1. Pull on the tab to open the tray 2 paper feeder door.

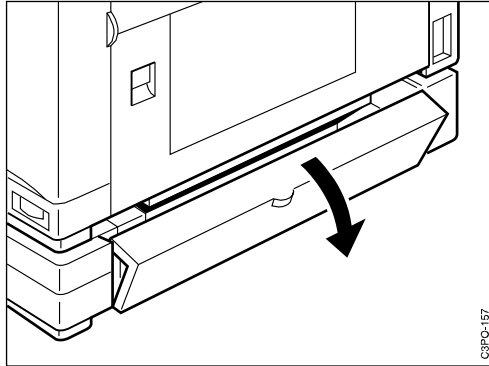

2. Carefully remove the jammed paper.

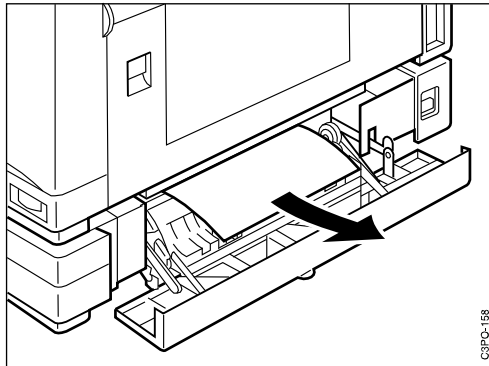

3. Close the tray 2 paper feeder door.

Correcting Print Quality Problems

This section tells you about problems you may have with the print quality of your printouts. Use the table below to find the information you need to correct these problems.

Problem	Table to use
Light prints	Table 1, "Light Image," on page 6-14
Dark prints	Table 2, "Dark image," on page 6-14
Completely blank prints	Table 3, "Blank Prints," on page 6-14
All-black prints (any color)	Table 4, "All Black (Any Color) Prints," on page 6-15
Back of paper dirty	Table 5, "Dirt on Back of Paper," on page 6-15
Dirty prints or background	Table 6, "Dirty Prints or Background," on page 6-16
Vertical lines of toner on print	Table 7, "Vertical Lines on Print," on page 6-16
White vertical lines on print	Table 8, "White Vertical Lines on Print," on page 6-17
White horizontal lines on print	Table 9, "White Horizontal Lines on Print," on page 6-17
Black spots on print	Table 10, "Black Spots," on page 6-18
Toner rubbing off prints	Table 11, "Poor Fusing," on page 6-18
Distorted image	Table 12, "Distortion," on page 6-18
Color distortion	Table 13, "Color Distortion," on page 6-19
Toner in streaks or scatter	Table 14, "Toner Streaking or Scatter," on page 6-19
Color missing or faded	Table 15, "Color Fading or Missing," on page 6-19

Use the following procedure when reading the tables in this section to diagnose and solve your print quality problem.

1. Locate step 1 in the table.
2. Perform the contents of the column entitled **Action**.
3. Print a test page to determine if the problem is solved.
4. Repeat this process until one of the following events occurs:
 - a. You solve the print quality problem.
 - b. You run out of steps to consult. In this event, call your authorized IBM service representative and report the problem.

Table 1: Light Image

Step	Action
1.	Clean the separation corona wire and the window of the density detection sensor (see "Cleaning the Separation Corona Wire" on page 8-3 and "Cleaning the Window of the Density Detection Sensor" on page 8-4).
2.	Clean the transfer drum (see "Cleaning the Transfer Drum" on page 8-3).
3.	Make sure that the paper loaded in the printer meets the specifications listed in "Choosing Paper" on page 2-2.
4.	Run several full-color gradient test prints from the density control panel (see "Printing Test Prints from the Density Control Panel" on page 6-24). <ul style="list-style-type: none"> • If all the colors are light on the test prints, replace the photoconductor drum cartridge (see "Replacing the Photoconductor Drum Cartridge" on page 5-33). • If only some of the colors are light, replace the toner cartridge for each color that is light (see "Replacing Toner Cartridges" on page 5-4).
5.	Adjust the color density (see "Adjusting the Color Density" on page 6-22).

Table 2: Dark image

Step	Action
1.	Clean the window of the density detection sensor (see "Cleaning the Window of the Density Detection Sensor" on page 8-4).
2.	Make sure that the paper loaded in the printer meets the specifications listed in "Choosing Paper" on page 2-2.
3.	Replace the photoconductor drum cartridge (see "Replacing the Photoconductor Drum Cartridge" on page 5-33).
4.	Adjust the color density (see "Adjusting the Color Density" on page 6-22).

Table 3: Blank Prints

Step	Action
1.	Use the illustration below to identify the front door laser interlock. If the laser interlock is damaged, call for service to repair or replace the front door. <div data-bbox="703 1430 1239 1749" data-label="Image"> </div>
2.	Replace the photoconductor drum cartridge (see "Replacing the Photoconductor Drum Cartridge" on page 5-33).
3.	Replace the toner cartridges (see "Replacing Toner Cartridges" on page 5-4).

Table 4: All Black (Any Color) Prints

Step	Action
1.	Run several full-color gradient test prints from the density control panel (see "Printing Test Prints from the Density Control Panel" on page 6–24). If the problem goes away, call for service to replace the control unit.
2.	Replace the photoconductor drum cartridge (see "Replacing the Photoconductor Drum Cartridge" on page 5–33).

Table 5: Dirt on Back of Paper

Step	Action
1.	Power on the printer to initiate a warmup cycle.
2.	Inspect the transfer drum after the warmup cycle is finished. <ul style="list-style-type: none"> • If the transfer drum surface is clean, go to step 4 • If the transfer drum surface is dirty, go to step 3
3.	Make sure that the transfer drum cleaning assembly is fully seated and locked in place (see "Replacing the Transfer Drum Cleaning Assembly" on page 8–12).
 <2-6> CAUTION: High temperature. Switch off printer power and allow at least 15 minutes for parts in this area to cool before handling.	
4.	Check the fuser rollers for flaws or dirt buildup. <ul style="list-style-type: none"> • If you see flaws on the fuser rollers, replace the fuser unit (see "Replacing the Fuser" on page 5–19). • If you see dirt on the fuser rollers, try to remove it using the procedure described in "Cleaning the Fuser Rollers" on page 8–5. • If you cannot remove all of the dirt, replace the fuser unit.
5.	Make sure you are not using predrilled paper, which may damage the printer. See "Choosing Paper" on page 2–2.
6.	Inspect the entire paper path for dirt and toner. Clean the paper path as required (see "Cleaning the Paper Path" on page 8–3).

Table 6: Dirty Prints or Background

Step	Action
1.	Make sure that the paper loaded in the printer meets the specifications listed in "Choosing Paper" on page 2-2.
2.	Inspect the entire paper path for dirt and toner. Clean the paper path as required (see "Cleaning the Paper Path" on page 8-3).
3.	Replace the photoconductor drum cartridge (see "Replacing the Photoconductor Drum Cartridge" on page 5-33).

Table 7: Vertical Lines on Print

Step	Action
1.	Run several full-color gradient test prints from the density control panel (see "Printing Test Prints from the Density Control Panel" on page 6-24). <ul style="list-style-type: none"> • If the vertical line appears on 1 color only, replace the toner cartridge for that color (see "Replacing Toner Cartridges" on page 5-4). • Otherwise, go to step 2.
2.	Replace the photoconductor drum cartridge (see "Replacing the Photoconductor Drum Cartridge" on page 5-33).
 <2-6> CAUTION: High temperature. Switch off printer power and allow at least 15 minutes for parts in this area to cool before handling.	
3.	Check the fuser rollers for flaws or dirt buildup. <ul style="list-style-type: none"> • If you see flaws on the fuser rollers, replace the fuser unit (see "Replacing the Fuser" on page 5-19). • If you see dirt on the fuser rollers, try to remove it using the procedure described in "Cleaning the Fuser Rollers" on page 8-5. • If you cannot remove all of the dirt, replace the fuser unit.
4.	Inspect the entire paper path for dirt and toner. Clean the paper path as required (see "Cleaning the Paper Path" on page 8-3).
5.	Clean the separation corona wire (see "Cleaning the Separation Corona Wire" on page 8-3).
6.	Replace the separation corona unit (see "Replacing the Separation Corona Unit" on page 8-10).

Table 8: White Vertical Lines on Print

Step	Action
1.	Run several full-color gradient test prints from the density control panel (see "Printing Test Prints from the Density Control Panel" on page 6–24). <ul style="list-style-type: none"> • If the vertical line appears on 1 color only, replace the toner cartridge for that color (see "Replacing Toner Cartridges" on page 5–4). • Otherwise, go to step 2.
2.	Replace the photoconductor drum cartridge (see "Replacing the Photoconductor Drum Cartridge" on page 5–33).
 <2-6> CAUTION: High temperature. Switch off printer power and allow at least 15 minutes for parts in this area to cool before handling.	
3.	Check the fuser rollers for flaws or dirt buildup. <ul style="list-style-type: none"> • If you see flaws on the fuser rollers, replace the fuser unit (see "Replacing the Fuser" on page 5–19). • If you see dirt on the fuser rollers, try to remove it using the procedure described in "Cleaning the Fuser Rollers" on page 8–5. • If you cannot remove all of the dirt, replace the fuser unit.
4.	Inspect the entire paper path for dirt and toner. Clean the paper path as required (see "Cleaning the Paper Path" on page 8–3).
5.	Clean the separation corona wire (see "Cleaning the Separation Corona Wire" on page 8–3).
6.	Replace the separation corona unit (see "Replacing the Separation Corona Unit" on page 8–10).

Table 9: White Horizontal Lines on Print

Step	Action
1.	Run several full-color gradient test prints from the density control panel (see "Printing Test Prints from the Density Control Panel" on page 6–24). <ul style="list-style-type: none"> • If the horizontal line appears on 1 color only, replace the toner cartridge for that color (see "Replacing Toner Cartridges" on page 5–4). • Otherwise, go to step 2.
2.	Replace the photoconductor drum cartridge (see "Replacing the Photoconductor Drum Cartridge" on page 5–33).
 <2-6> CAUTION: High temperature. Switch off printer power and allow at least 15 minutes for parts in this area to cool before handling.	
3.	Check the fuser rollers for flaws or dirt buildup. <ul style="list-style-type: none"> • If you see flaws on the fuser rollers, replace the fuser unit (see "Replacing the Fuser" on page 5–19). • If you see dirt on the fuser rollers, try to remove it using the procedure described in "Cleaning the Fuser Rollers" on page 8–5. • If you cannot remove all of the dirt, replace the fuser unit.

Table 10: Black Spots

Step	Action
1.	Run several full-color gradient test prints from the density control panel (see "Printing Test Prints from the Density Control Panel" on page 6–24). <ul style="list-style-type: none"> • If the spots appear on 1 color only, replace the toner cartridge for that color (see "Replacing Toner Cartridges" on page 5–4). • Otherwise, go to step 2.
2.	Replace the photoconductor drum cartridge (see "Replacing the Photoconductor Drum Cartridge" on page 5–33).
3.	Make sure that the paper loaded in the printer is free of excess moisture and meets the specifications listed in "Choosing Paper" on page 2–2.
4.	Clean the transfer drum (see "Cleaning the Transfer Drum" on page 8–3).

Table 11: Poor Fusing

Step	Action
1.	Make sure that the paper loaded in the printer is free of defects and meets the specifications listed in "Choosing Paper" on page 2–2.
	 <2-6> CAUTION: High temperature. Switch off printer power and allow at least 15 minutes for parts in this area to cool before handling.
2.	Check the fuser rollers for flaws or dirt buildup. <ul style="list-style-type: none"> • If you see flaws on the fuser rollers, replace the fuser unit (see "Replacing the Fuser" on page 5–19). • If you see dirt on the fuser rollers, try to remove it using the procedure described in "Cleaning the Fuser Rollers" on page 8–5. • If you cannot remove all of the dirt, replace the fuser unit.

Table 12: Distortion

Step	Action
1.	Make sure that the temperature and humidity of the room in which the printer is located are within the specifications described in the <i>Installation and Relocation Guide</i> . See the <i>Installation and Relocation Guide</i> for correct environmental values.
2.	Make sure that the printer is not subjected to vibration.

Table 13: Color Distortion

Step	Action
1.	Make sure that the paper in the printer is free of defects and meets the specifications listed in "Choosing Paper" on page 2-2.
2.	Replace the photoconductor drum cartridge (see "Replacing the Photoconductor Drum Cartridge" on page 5-33).
3.	Clean the transfer drum (see "Cleaning the Transfer Drum" on page 8-3).

Table 14: Toner Streaking or Scatter

Step	Action
1.	Make sure that the paper loaded in the printer is free of excess moisture and meets the specifications listed in "Choosing Paper" on page 2-2.
2.	Set the separation corona mode to so that the forcible control is OFF (see "Setting the Separation Corona Mode" on page 6-26). If this improves the print quality, set the separation corona mode on or off as needed to compensate for the environment.
 <2-6> CAUTION: High temperature. Switch off printer power and allow at least 15 minutes for parts in this area to cool before handling.	
3.	<p>Check the fuser rollers for flaws or dirt buildup.</p> <ul style="list-style-type: none"> • If you see flaws on the fuser rollers, replace the fuser unit (see "Replacing the Fuser" on page 5-19). • If you see dirt on the fuser rollers, try to remove it using the procedure described in "Cleaning the Fuser Rollers" on page 8-5. • If you cannot remove all of the dirt, replace the fuser unit.

Table 15: Color Fading or Missing

Step	Action
1.	<p>Run several full-color gradient test prints from the density control panel (see "Printing Test Prints from the Density Control Panel" on page 6-24).</p> <ul style="list-style-type: none"> • If the color is missing or fading on 1 color only, replace the toner cartridge for that color (see "Replacing Toner Cartridges" on page 5-4). • Otherwise, go to step 2.
2.	Make sure that the paper loaded in the printer is free of excess moisture and meets the specifications listed in "Choosing Paper" on page 2-2.

Adjusting the Side Registration on Tray 2 Printouts

This section tells you how to adjust the side registration on tray 2 printouts.

If you are using the optional tray 2 paper feeder and you notice that the margins on your printouts are not the same as when you use the tray 1 paper feeder, you may need to adjust the tray 2 side registration to match that of tray 1 (approximately 2 mm or 0.08 inches).

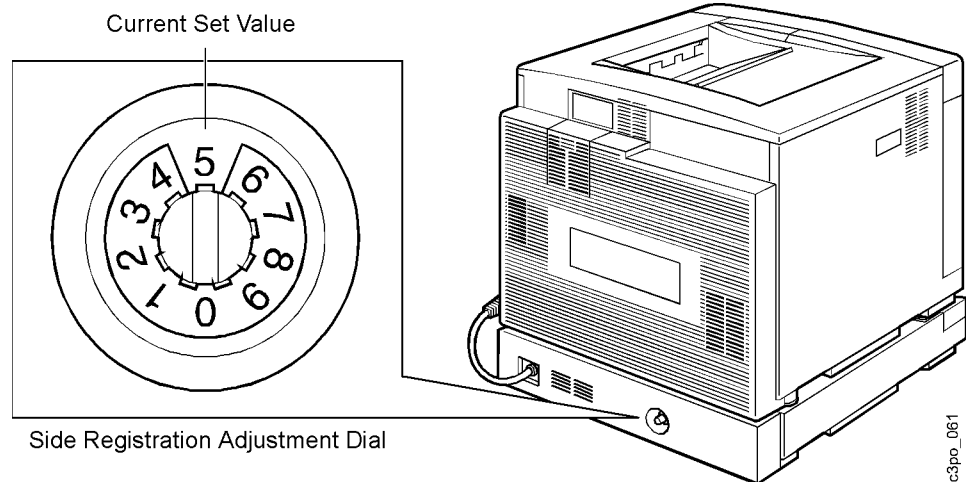

You can set the side registration adjustment dial from 0 to 9. The value on the top part of the dial is the current value. The dial is set to 5 at the factory. When you increase the dial value by 1, the left-side registration increases by approximately 0.4 mm (0.16 inches). When you decrease the dial value by 1, the left-side registration decreases by approximately 0.4 mm (0.16 inches).

Use the following procedure to adjust the left-side registration.

1. Load tray 2 with the same size of paper that is in tray 1 (see “Loading Paper” on page 3–2).
2. Turn on the printer and wait until it is ready to print.
3. Change the paper source to tray 2 (see “Choosing the Paper Source” on page 4–14).
4. Locate the density control panel on the back of the printer.
5. Print a test print (see “Printing Test Prints from the Density Control Panel” on page 6–24). Choose the Solid Colors test print pattern.

6. Measure the left margin of the test print.

If the left margin is 2 mm (0.08 inches), you do not have to adjust the registration. If the left margin is wider or narrower than 2 mm (0.08 inches), calculate the difference. Use this measurement to adjust the registration with the side registration adjustment dial.

Example

When the left margin is 2.8 mm

$$2.8 \text{ mm} - 2.0 \text{ mm} = 0.8 \text{ mm (Decrease the margin by 0.8 mm.)}$$

$$0.8 \text{ mm} \div 0.4 \text{ mm} = 2 \text{ (Decrease the dial value by 2.)}$$

7. For the example above, turn the dial from 5 to 3. Use a screwdriver or your hand to turn the dial.
8. Print another test print and check if the left margin is 2 mm (0.08 inches). If the margin is still not 2 mm (0.08 inches), repeat step 6 through step 8.

Adjusting the Color Density

This section tells you how to make minor adjustments to the color density from the density control panel.

Note: If you use a Macintosh and have a color calibration hardware device (such as a Status T or XRite densitometer; see the *User's Guide* for specifications), then you can use the Calibrator utility supplied on the utility diskette that came with this printer to test the accuracy of the color density. (See the *User's Guide* for information regarding this program.)

Generally, you do not need to make any adjustments to the color density. The printer conducts an automatic density adjustment when you turn it on and after printing a prescribed number of pages. If the color density does not match your configured selections, print a test page (see "Printing a Test Page" on page 4–10) and compare it to the test page that you printed when you installed the printer.

Note: If you change the color density using the instructions that follow, the printed color may not match the color specified by print jobs.

Use the following procedure to adjust the color density.

1. Find the density control panel on the back of the printer.
2. Press the **COLOR SELECT** push button to choose the color you want. The color density light for the color you selected goes on.

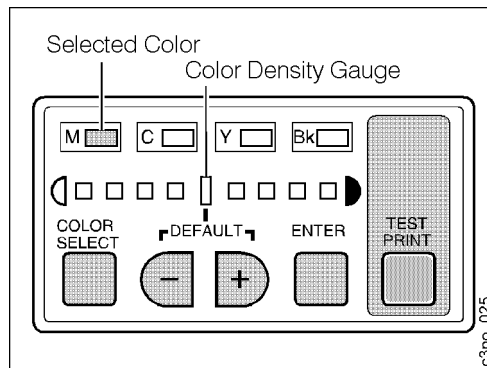

3. Use the (–) or (+) push button to adjust the density of the color you selected. The light for the density you selected flashes if the setting is different from the factory default.

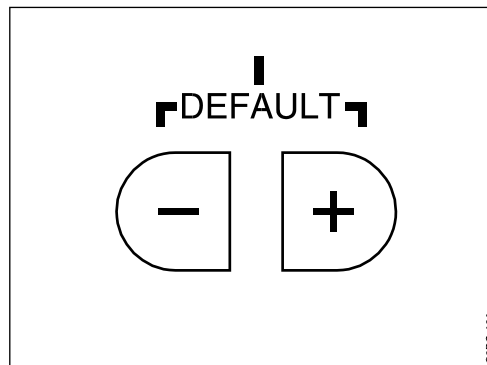

4. Press the **ENTER** push button to confirm the density change of the color you selected. The light for the density you selected stops flashing and remains on.

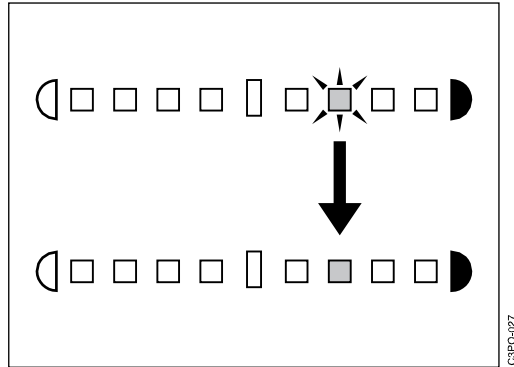

5. To adjust the other colors, repeat the steps above.
6. Print a test page (see “Printing a Test Page” on page 4–10) and compare it to the test page that you printed when you installed the printer.

Notes:

1. The new color density remains in effect after you turn off the printer.
2. The density control panel returns to an idle state if no activity is detected within 20 seconds. In this state, the **COLOR SELECT** display goes off, and only the **DEFAULT** light on the density gauge lights up if all color settings are the same as the factory default settings; otherwise they will all go off. **If you press the (-) and (+) push buttons for more than 5 seconds, all the color density values are restored to the factory default settings.**

Printing Test Prints from the Density Control Panel

This section tells you how to print a test print using the density control panel.

You can print test prints in various grid and line patterns to use during diagnostic procedures. Use the following procedure to print a test print from the density control panel.

1. While you hold down the **COLOR SELECT** push button, press the **ENTER** push button 8 times. All the color lights flash and the printer enters the test pattern selection mode.

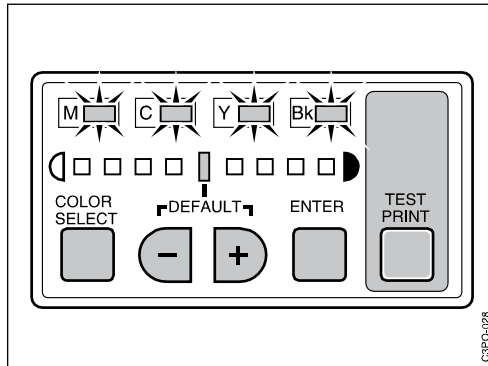

2. Use the (-) or (+) push button to choose a test pattern. The light for the test pattern you selected flashes if the setting is different from the factory default.

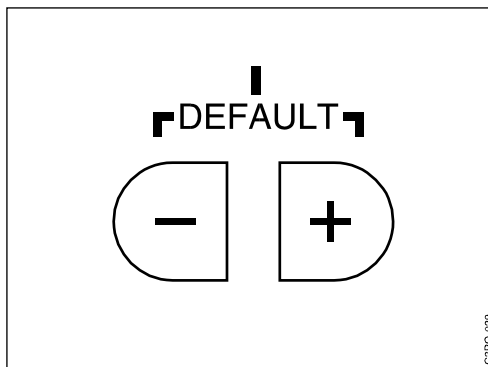

3. Press the **ENTER** push button to confirm the test pattern you selected. The light for the test pattern you selected goes on.

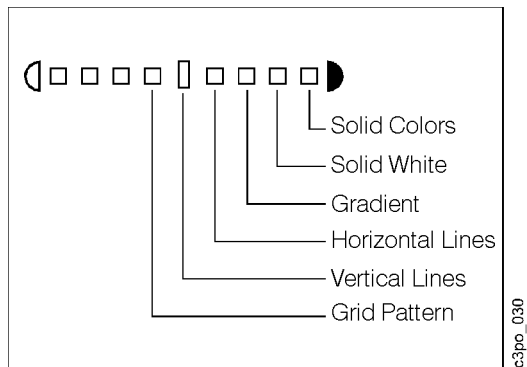

4. Press the **TEST PRINT** push button to print the test pattern.

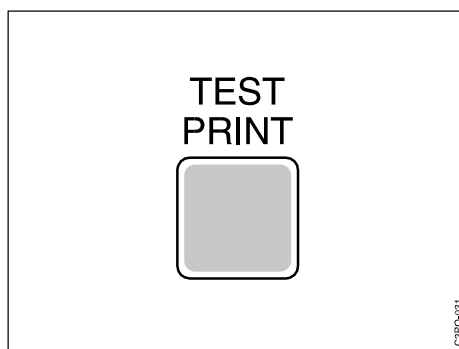

Setting the Separation Corona Mode

This section tells you how to set the separation corona mode using the density control panel.

You may need to set the operational mode of the separation corona to resolve a particular print quality problem. The separation corona can be on or off or set to function automatically (sensitive to temperature and humidity).

Use the following procedure to set the separation corona mode.

1. While holding down the **COLOR SELECT** push button, press the **ENTER** push button 3 times. The **Y** and **Bk** color select lights flash to indicate that you can set the mode of the separation corona.

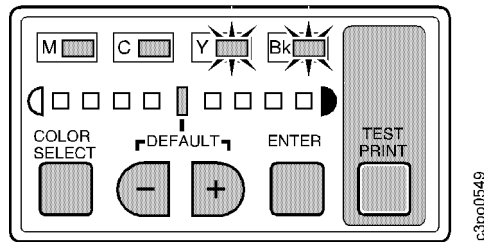

2. Use the (-) or (+) push button to select the separation corona mode. If the chosen mode differs from that currently selected in the printer, the density gauge light flashes.

The correspondence between the density gauge lights and each separation corona mode is as follows:

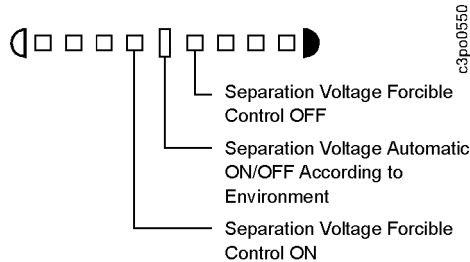

3. Press the **ENTER** push button to confirm the separation corona mode. The density gauge light comes on and the printer changes the separation corona mode.

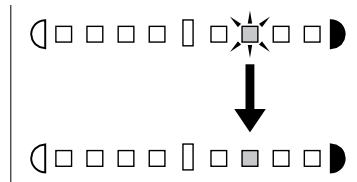

Chapter 7. Understanding Operator Messages

This chapter lists the messages that you may see on the display panel, tells you the reason for the message, and tells you what to do. Messages on the display panel tell you the printer's status and alert you to upcoming problems. If the printer has an error during operation, you see an error message on the display panel.

This chapter covers the following topics:

Understanding POST Error Messages	7-2
Function of POST Error Messages	7-2
Table of POST Error Messages	7-2
Understanding Operator Messages	7-5
Understanding Warning Messages	7-5
Understanding Status Messages	7-7
Understanding Operator Error Messages	7-8

Understanding POST Error Messages

This section tells you how to understand and respond to the power-on self-test (POST) error messages.

Function of POST Error Messages

The printer fuser takes approximately 5 minutes to warm up if it is cold when you turn the printer on. While the printer is warming up, it runs a power-on self-test (POST). The POST checks to see if the printer is working correctly.

As the POST runs, you see status messages on the display panel. You do not have to read these messages unless the POST stops before the test is finished. Normally, the POST finishes without problems and you see the READY message on the display panel.

If the POST does stop before it is finished, the **Attention** light on the display panel flashes. Check the display panel for a message, an error code, or a blank display. See the following table to find out what to do.

Table of POST Error Messages

This table lists the error messages that can occur when a POST fails and what you should do for each message. When you are instructed to call for service, call **1-800-358-6661**. See "Requesting Service" on page xiii for further information.

POST Error Messages	
Message	Suggested Action
EPROM 100	<ol style="list-style-type: none">1. Turn the printer off. Wait for 90 seconds.2. Turn the printer on. If the message recurs, call for service and report an EPROM 100 error.
EEPROM 200	<ol style="list-style-type: none">1. Turn the printer off. Wait for 90 seconds.2. Turn the printer on. If the message recurs, call for service and report an EEPROM 200 error.
MIPS FPU 900	<ol style="list-style-type: none">1. Turn the printer off. Wait for 90 seconds.2. Turn the printer on. If the message recurs, call for service and report a MIPS FPU 900 error.
RTC SELF 700	<ol style="list-style-type: none">1. Turn the printer off. Wait for 90 seconds.2. Turn the printer on. If the message recurs, call for service and report an RTC SELF 700 error.
RTC R/W REG 710	<ol style="list-style-type: none">1. Turn the printer off. Wait for 90 seconds.2. Turn the printer on. If the message recurs, call for service and report an RTC R/W REG 710 error.
RTC START 730	<ol style="list-style-type: none">1. Turn the printer off. Wait for 90 seconds.2. Turn the printer on. If the message recurs, call for service and report an RTC START 730 error.
RTC SET 740	<ol style="list-style-type: none">1. Turn the printer off. Wait for 90 seconds.2. Turn the printer on. If the message recurs, call for service and report an RTC SET 740 error.

POST Error Messages	
Message	Suggested Action
DRAM SIMM 310	<ol style="list-style-type: none"> 1. Turn the printer off. Wait for 90 seconds. 2. If this is the second time for this error, turn the printer off and disconnect it from the wall outlet. Remove the controller and reseat all memory SIMMs. (See the <i>Quick Setup Guide</i> for details.) 3. Turn the printer on. If the message recurs, call for service and report error DRAM SIMM 310.
DRAM SLOT 320	<ol style="list-style-type: none"> 1. Turn the printer off. Wait for 90 seconds. 2. Turn the printer on. If the message recurs, call for service and report a DRAM SLOT 320 error.
DRAM CONFIG 330 or 350	<ol style="list-style-type: none"> 1. Turn the printer off. Wait for 90 seconds. 2. Turn the printer on. If the message recurs, call for service and report a DRAM CONFIG 330 or 350 error.
DRAM CONFIG D00	<ol style="list-style-type: none"> 1. Turn the printer off. Wait for 90 seconds. 2. Turn the printer on. If the message recurs, call for service and report a DRAM CONFIG D00 error.
DRAM 340	<ol style="list-style-type: none"> 1. Turn the printer off. Wait for 90 seconds. 2. Turn the printer on. If the message recurs, call for service and report a DRAM 340 error.
ACA DMA CNFG B00	<ol style="list-style-type: none"> 1. Turn the printer off. Wait for 90 seconds. 2. Turn the printer on. If the message recurs, call for service and report an ACA DMA CNFG B00 error.
ACA DMA ADR B10	<ol style="list-style-type: none"> 1. Turn the printer off. Wait for 90 seconds. 2. Turn the printer on. If the message recurs, call for service and report an ACA DMA ADR B10 error.
ACA CNTL REG A00	<ol style="list-style-type: none"> 1. Turn the printer off. Wait for 90 seconds. 2. Turn the printer on. If the message recurs, call for service and report an ACA CNTL REG A00 error.
ACA VADR REG 5A0	<ol style="list-style-type: none"> 1. Turn the printer off. Wait for 90 seconds. 2. Turn the printer on. If the message recurs, call for service and report an ACA VADR REG 5A0 error.
ACA VCNT REG B50	<ol style="list-style-type: none"> 1. Turn the printer off. Wait for 90 seconds. 2. Turn the printer on. If the message recurs, call for service and report an ACA VCNT REG B50 error.
ETH FUSE 400	<ol style="list-style-type: none"> 1. Turn the printer off. Wait for 90 seconds. 2. Turn the printer on. If the message recurs, call for service and report an ETH FUSE 400 error.
ETH QUIET 410	<ol style="list-style-type: none"> 1. Turn the printer off. Wait for 90 seconds. 2. Turn the printer on. If the message recurs, call for service and report an ETH QUIET 410 error.
ETH IDLE 420	<ol style="list-style-type: none"> 1. Turn the printer off. Wait for 90 seconds. 2. Turn the printer on. If the message recurs, call for service and report an ETH IDLE 420 error.
ETH SELF 450	<ol style="list-style-type: none"> 1. Turn the printer off. Wait for 90 seconds. 2. Turn the printer on. If the message recurs, call for service and report an ETH SELF 450 error.

POST Error Messages	
Message	Suggested Action
ETH INTLPBK 440-442 460-462 470-472 490 4A0-4A2 4B0-4B3 4D0 4E0 4F0	<ol style="list-style-type: none"> 1. Turn the printer off. Wait for 90 seconds. 2. Turn the printer on. If the message recurs, call for service and report the error displayed.
SCSI FUSE 600	<ol style="list-style-type: none"> 1. Turn the printer off. Wait for 90 seconds. 2. Turn the printer on. If the message recurs, call for service and report a SCSI FUSE 600 error.
SCSI QUIET 650	<ol style="list-style-type: none"> 1. Turn the printer off. Wait for 90 seconds. 2. Turn the printer on. If the message recurs, call for service and report a SCSI QUIET 650 error.
SCSI CMD REG 640	<ol style="list-style-type: none"> 1. Turn the printer off. Wait for 90 seconds. 2. Turn the printer on. If the message recurs, call for service and report a SCSI CMD REG 640 error.
SCSI R/W REG 630	<ol style="list-style-type: none"> 1. Turn the printer off. Wait for 90 seconds. 2. Turn the printer on. If the message recurs, call for service and report a SCSI R/W REG 630 error.
SCSI RUPT RST 610	<ol style="list-style-type: none"> 1. Turn the printer off. Wait for 90 seconds. 2. Turn the printer on. If the message recurs, call for service and report a SCSI RUPT RST 610 error.
SCSI RUPT II 611	<ol style="list-style-type: none"> 1. Turn the printer off. Wait for 90 seconds. 2. Turn the printer on. If the message recurs, call for service and report a SCSI RUPT II 611 error.
SCSI FIFO 621	<ol style="list-style-type: none"> 1. Turn the printer off. Wait for 90 seconds. 2. Turn the printer on. If the message recurs, call for service and report a SCSI FIFO 621 error.
SCSI DEVICE 660	<ol style="list-style-type: none"> 1. Turn the printer off. Wait for 90 seconds. 2. Turn the printer on. If the message recurs, call for service and report a SCSI DEVICE 660 error.

Understanding Operator Messages

This section explains the 3 classes of operator messages and lists the messages that you are likely to see in each class.

There are 3 classes of operator messages:

- Warning messages
- Status messages
- Error messages

If the printer needs to display a message from more than one class, it uses the following display priority:

Priority	Message
Highest	Error
Medium	Status
Lowest	Warning

For example, if the printer sends an error message while a status message is displayed, the error message replaces the status message on the display panel.

Understanding Warning Messages

A warning message alerts you to an upcoming problem. When an operator warning occurs, printing continues and the **Attention** light flashes. Press **Enter** to see the message on the display panel.

If more than one warning message is pending at one time, you see the first warning message with a (+) character to the right of the message. You can use the **Menu Scrolling** push buttons to scroll up and down the list of messages.

List of Warning Messages

The table on page 7–6 lists warning messages that you may see, gives a brief description of the problem, and tells you what to do to fix it. When you are instructed to call for service, call **1-800-358-6661**. See “Requesting Service” on page xiii for further information.

Note: The operator action most likely to solve the problem is listed first.

Operator Warning Messages

Message	Problem	Action
BLACK TONER LOW	The black toner cartridge is almost empty.	<ol style="list-style-type: none"> 1. When the print quality begins to degrade, replace the black toner cartridge. See "Replacing Toner Cartridges" on page 5-4. 2. If the problem continues after you install a new cartridge, call for service.
CLEAN SENSOR & TRANSFER DRUM	There is a density sensor error or the sensor is dirty.	<ol style="list-style-type: none"> 1. Clean the density detection sensor. See "Cleaning the Window of the Density Detection Sensor" on page 8-4. 2. If the problem continues, call for service.
CLEANER BELT LOW GET PRINT COUNT	The fuser cleaning belt is nearly worn out.	<ol style="list-style-type: none"> 1. Print a configuration page. See "Printing a Configuration Page" on page 4-9. 2. Record the print count number for later reference. 3. Replace the fuser. See "Replacing the Fuser" on page 5-19. 4. If the problem continues after you replace the fuser, call for service. <p>Note: A fuser can print approximately 60 000 pages under normal operating conditions. If you print on transparencies, this number becomes smaller.</p>
CYAN TONER LOW	The cyan toner cartridge is almost empty.	<ol style="list-style-type: none"> 1. When the print quality begins to degrade, replace the cyan toner cartridge. See "Replacing Toner Cartridges" on page 5-4. 2. If the problem continues after you install a new cartridge, call for service.
FUSER OIL LOW	The fuser oil supply is low.	<ol style="list-style-type: none"> 1. Replace the fuser oil bottle within the next 50 prints. See "Replacing the Fuser Oil Bottle" on page 5-16. 2. If the problem continues after you replace the fuser oil bottle, call for service.
MAGENTA TONER LOW	The magenta toner cartridge is almost empty.	<ol style="list-style-type: none"> 1. When the print quality begins to degrade, replace the magenta toner cartridge. See "Replacing Toner Cartridges" on page 5-4. 2. If the problem continues after you install a new cartridge, call for service.
REPLACE DRUM TO ENSURE QUALITY	The photoconductor drum's sensitivity is low; the drum should be replaced.	<ol style="list-style-type: none"> 1. For the best print quality, replace the photoconductor drum cartridge. See "Replacing the Photoconductor Drum Cartridge" on page 5-33. 2. If the message continues after you replace the drum, call for service.
YELLOW TONER LOW	The yellow toner cartridge is almost empty.	<ol style="list-style-type: none"> 1. When the print quality begins to degrade, replace the yellow toner cartridge. See "Replacing Toner Cartridges" on page 5-4. 2. If the problem continues after you install a new cartridge, call for service.

Understanding Status Messages

A status message reports the current printer state. Printing is not affected. These messages are informational; you do not have to take any action.

These are the status messages that you will most likely see.

- READY
- PROCESSING
- PRINTING
- OFFLINE
- POWER SAVER MODE
- WARMING UP

Understanding Operator Error Messages

When you see an error message on the display panel, printing stops and the **Attention** light flashes. You see the error message until the error is resolved or until another error is encountered.

Table of Operator Error Messages

This table lists the error messages that you may see, gives a brief description of the problem, and tells you what to do. When you are instructed to call for service, call **1-800-358-6661**. See “Requesting Service” on page xiii for further information.

Note: The operator action most likely to solve the problem is listed first.

Operator Error Messages		
Message	Problem	Operator Action
A1 FUSER ERROR SEE OP. GUIDE	The fuser is below operating temperature.	<ol style="list-style-type: none"> 1. Make sure that the fuser is installed completely. See “Replacing the Fuser” on page 5–19. 2. Turn the printer off for 1 minute and then turn it back on. If the problem continues, go to step 3. 3. Replace the fuser. See “Replacing the Fuser” on page 5–19. If the problem continues after you replace the fuser, call for service and report error code A1. 4. Print a configuration page (see “Printing a Configuration Page” on page 4–9) and note the print count that it reports. Record this information on your Supplies Replacement Log, shown in Appendix B. <p>Note: A fuser can print approximately 60 000 pages under normal operating conditions. If you print on transparencies, this number becomes smaller.</p>
A2 FUSER ERROR SEE OP. GUIDE	The fuser did not warm-up correctly.	<ol style="list-style-type: none"> 1. Make sure that the fuser is installed completely. See “Replacing the Fuser” on page 5–19. 2. Turn the printer off for 1 minute and then turn it back on. If the problem continues, go to step 3. 3. Replace the fuser. See “Replacing the Fuser” on page 5–19. If the problem continues after you replace the fuser, call for service and report error code A2. 4. Print a configuration page (see “Printing a Configuration Page” on page 4–9) and note the print count that it reports. Record this information on your Supplies Replacement Log, shown in Appendix B. <p>Note: A fuser can print approximately 60 000 pages under normal operating conditions. If you print on transparencies, this number becomes smaller.</p>

Operator Error Messages

Message	Problem	Operator Action
A3 FUSER ERROR SEE OP. GUIDE	The fuser went above the normal operating temperature.	<ol style="list-style-type: none"> 1. Make sure that the fuser is installed completely. See "Replacing the Fuser" on page 5–19. 2. Turn the printer off for 1 minute and then turn it back on. If the problem continues, go to step 3. 3. Replace the fuser. See "Replacing the Fuser" on page 5–19. If the problem continues after you replace the fuser, call for service and report error code A3. 4. Print a configuration page (see "Printing a Configuration Page" on page 4–9) and note the print count that it reports. Record this information on your Supplies Replacement Log, shown in Appendix B. <p>Note: A fuser can print approximately 60 000 pages under normal operating conditions. If you print on transparencies, this number becomes smaller.</p>
A4 FUSER ERROR SEE OP. GUIDE	You tried to turn the printer on after a fuser failure and before the fuser had enough time to cool.	<ol style="list-style-type: none"> 1. Turn off the printer and allow the fuser to cool for a minimum of 30 minutes. 2. Turn the printer on. If the problem continues, go to step 3. 3. Replace the fuser. See "Replacing the Fuser" on page 5–19. If the problem continues after you replace the fuser, call for service and report error code A4. 4. Print a configuration page (see "Printing a Configuration Page" on page 4–9) and note the print count that it reports. Record this information on your Supplies Replacement Log, shown in Appendix B. <p>Note: A fuser can print approximately 60 000 pages under normal operating conditions. If you print on transparencies, this number becomes smaller.</p>
A5 FUSER ERROR SEE OP. GUIDE	The fuser failed.	<ol style="list-style-type: none"> 1. Make sure that the fuser is installed completely. See "Replacing the Fuser" on page 5–19. 2. Turn the printer off for 1 minute and then turn it back on. If the problem continues, go to step 3. 3. Replace the fuser. See "Replacing the Fuser" on page 5–19. If the problem continues after you replace the fuser, call for service and report error code A5. 4. Print a configuration page (see "Printing a Configuration Page" on page 4–9) and note the print count that it reports. Record this information on your Supplies Replacement Log, shown in Appendix B. <p>Note: A fuser can print approximately 60 000 pages under normal operating conditions. If you print on transparencies, this number becomes smaller.</p>

Operator Error Messages

Message	Problem	Operator Action
A6 FUSER ERROR SEE OP. GUIDE	One or both of the fuser heater elements may have failed.	<ol style="list-style-type: none"> 1. Make sure that the fuser is installed completely. See "Replacing the Fuser" on page 5–19. 2. Turn the printer off for 1 minute and then turn it back on. If the problem continues, go to step 3. 3. Replace the fuser. See "Replacing the Fuser" on page 5–19. If the problem continues after you replace the fuser, call for service and report error code A6. 4. Print a configuration page (see "Printing a Configuration Page" on page 4–9) and note the print count that it reports. Record this information on your Supplies Replacement Log, shown in Appendix B. <p>Note: A fuser can print approximately 60 000 pages under normal operating conditions. If you print on transparencies, this number becomes smaller.</p>
ADD FUSER OIL	The fuser oil supply is empty.	<ol style="list-style-type: none"> 1. Install a new bottle of fuser oil. See "Replacing the Fuser Oil Bottle" on page 5–16. 2. Print a configuration page (see "Printing a Configuration Page" on page 4–9) and note the print count that it reports. Record this information on your Supplies Replacement Log, shown in Appendix B. 3. If the problem continues, call for service.
B1 LASER ERROR SEE OP. GUIDE	The laser beam was not detected after the laser was activated.	<ol style="list-style-type: none"> 1. Turn off the printer to clear the error and then turn on the printer. 2. If the problem continues, call for service and report error code B1.
B2 LASER ERROR SEE OP. GUIDE	The laser failed to turn on.	<ol style="list-style-type: none"> 1. Turn off the printer to clear the error and then turn on the printer. 2. If the problem continues, call for service and report error code B2.
C5 LASER ERROR SEE OP. GUIDE	The laser mirror motor failed to start.	<ol style="list-style-type: none"> 1. Turn off the printer to clear the error and then turn on the printer. 2. If the problem continues, call for service and report error code C5.
C6 LASER ERROR SEE OP. GUIDE	The laser mirror motor speed is not correct.	<ol style="list-style-type: none"> 1. Turn off the printer to clear the error and then turn on the printer. 2. If the problem continues, call for service and report error code C6.
CLOSE DOOR	The front door, feeder access door, or fuser access door is open.	<ol style="list-style-type: none"> 1. Check that the front door, the feeder access door, and the fuser access door are closed and latched. 2. If any door does not close, check for obstructions. 3. If the problem continues, call for service.
D0 MOTOR ERROR SEE OP. GUIDE	The developer motor is not working correctly.	<ol style="list-style-type: none"> 1. Make sure that all toner cartridges are seated correctly. 2. Turn off the printer to clear the error and then turn on the printer. 3. If the problem continues, call for service and report error code D0.

Operator Error Messages		
Message	Problem	Operator Action
D2 MOTOR ERROR SEE OP. GUIDE	The drum motor is not working correctly.	<ol style="list-style-type: none"> 1. Open the front door and top cover. Lower the release handle and turn the transfer drum knob while you watch the transfer drum rotate. 2. If the drum does not rotate smoothly, install a new photoconductor drum cartridge (see "Replacing the Photoconductor Drum Cartridge" on page 5–33). 3. Print a configuration page (see "Printing a Configuration Page" on page 4–9) and note the print count that it reports. Record this information on your Supplies Replacement Log, shown in Appendix B. 4. Turn off the printer to clear the error and then turn on the printer. 5. If the problem continues after you install a different drum, reinstall the original drum, call for service, and report error code D2.
D3 MOTOR ERROR SEE OP. GUIDE	The main motor is not working correctly.	<ol style="list-style-type: none"> 1. Do the following to check for binds and clear the error: <ol style="list-style-type: none"> a. Open the fuser access door and check that the fuser is installed completely. b. Move the fuser jam-release lever up and down several times and check that the fuser rollers are not binding. If the rollers are binding, replace the fuser. See "Replacing the Fuser" on page 5–19. 2. Turn off the printer to clear the error and then turn on the printer. 3. Install a different photoconductor drum cartridge. See "Replacing the Photoconductor Drum Cartridge" on page 5–33. 4. Print a configuration page (see "Printing a Configuration Page" on page 4–9) and note the print count that it reports. Record this information on your Supplies Replacement Log, shown in Appendix B. 5. If the problem continues after you install a new drum, reinstall the original drum, call for service, and report error code D3.
D4 FAN ERROR SEE OP. GUIDE	The controller fan is not working correctly.	<ol style="list-style-type: none"> 1. Turn off the printer to clear the error and then turn on the printer. 2. If the problem continues, call for service and report error code D4.
D5 FAN ERROR SEE OP. GUIDE	The fuser fan is not working correctly.	<ol style="list-style-type: none"> 1. Make sure that the fan opening is not blocked. 2. Remove the filter holder. Clean or replace the air filter and the ozone filter, if needed. See "Replacing the Air and Ozone Filters" on page 8–6. 3. Turn off the printer to clear the error and then turn on the printer. 4. If the problem continues, call for service and report error code D5.

Operator Error Messages

Message	Problem	Operator Action
D6 FAN ERROR SEE OP. GUIDE	The electronics fan is blocked or failing.	<ol style="list-style-type: none"> 1. Turn off the printer to clear the error and then turn on the printer. 2. If the problem continues, call for service and report error code D6.
E5 ROTARY ERROR SEE OP. GUIDE	The cartridge rotary unit is not rotating correctly.	<ol style="list-style-type: none"> 1. Make sure that each toner cartridge is fully seated. 2. Turn off the printer to clear the error and then turn on the printer. 3. If the problem continues, call for service and report error code E5.
E6 CART. ERROR SEE OP. GUIDE	A toner cartridge is failing to move into or out of print position.	<ol style="list-style-type: none"> 1. Make sure that all cartridges are installed completely. 2. Turn off the printer to clear the error and then turn on the printer. 3. If the problem continues after you perform the above steps, identify which cartridge is failing to move, if possible. Replace that cartridge. See "Replacing Toner Cartridges" on page 5–4. If you cannot identify the cartridge, call for service and report error code E6. 4. Print a configuration page (see "Printing a Configuration Page" on page 4–9) and note the print count that it reports. Record this information on your Supplies Replacement Log, shown in Appendix B.
F1 CONTROL ERROR SEE OP. GUIDE	The DC controller detected an internal memory error.	<ol style="list-style-type: none"> 1. Turn off the printer to clear the error and then turn on the printer. 2. If the problem continues, call for service and report error code F1.
F2 CONTROL ERROR SEE OP. GUIDE	The DC controller detected an internal voltage error.	<ol style="list-style-type: none"> 1. Check that the printer power cord is securely plugged into an approved outlet. 2. Turn off the printer to clear the error and then turn on the printer. 3. If the problem continues, call for service and report error code F2.
F3 CONTROL ERROR SEE OP. GUIDE	The DC controller detected a thermal/humidity unit error.	<ol style="list-style-type: none"> 1. Turn off the printer to clear the error and then turn on the printer. 2. If the problem continues, call for service and report error code F3.
F4 SENSOR ERROR SEE OP. GUIDE	The density detection sensor is not working correctly.	<ol style="list-style-type: none"> 1. Clean the density detection sensor. See "Cleaning the Window of the Density Detection Sensor" on page 8–4. 2. Turn off the printer to clear the error and then turn on the printer. 3. If the problem continues, call for service and report error code F4.
F5 CONTROL ERROR SEE OP. GUIDE	There is an internal communications printer error.	<ol style="list-style-type: none"> 1. Turn off the printer to clear the error and then turn on the printer. 2. If the problem continues, call for service and report error code F5.

Operator Error Messages		
Message	Problem	Operator Action
F6 CONTROL ERROR SEE OP. GUIDE	The DC controller is not working correctly.	<ol style="list-style-type: none"> 1. Turn off the printer to clear the error and then turn on the printer. 2. If the problem continues, call for service and report error code F6.
FUSER CLEANER BELT FAILURE	The fuser cleaning belt or the belt sensor has failed.	<ol style="list-style-type: none"> 1. Replace the fuser. See “Replacing the Fuser” on page 5–19. If the problem continues after you replace the fuser, call for service. 2. Print a configuration page (see “Printing a Configuration Page” on page 4–9) and note the print count that it reports. Record this information on your Supplies Replacement Log, shown in Appendix B. <p>Note: A fuser can print approximately 60 000 pages under normal operating conditions. If you print on transparencies, this number becomes smaller.</p>
FUSER PUMP ERROR SEE OP. GUIDE	The fuser oil pump or the oil overflow sensor has failed.	<ol style="list-style-type: none"> 1. Make sure that the fuser is installed completely. See “Replacing the Fuser” on page 5–19. 2. Turn the printer off for 1 minute and then turn it back on. If the problem continues, go to step 3. 3. Replace the fuser. See “Replacing the Fuser” on page 5–19. If the problem continues after you replace the fuser, call for service. 4. Print a configuration page (see “Printing a Configuration Page” on page 4–9) and note the print count that it reports. Record this information on your Supplies Replacement Log, shown in Appendix B. <p>Note: A fuser can print approximately 60 000 pages under normal operating conditions. If you print on transparencies, this number becomes smaller.</p>
INSTALL BLACK TONER CARTRIDGE	The black toner cartridge is not installed.	<ol style="list-style-type: none"> 1. Install a black toner cartridge. See “Replacing Toner Cartridges” on page 5–4. 2. Print a configuration page (see “Printing a Configuration Page” on page 4–9) and note the print count that it reports. Record this information on your Supplies Replacement Log, shown in Appendix B. 3. If the problem continues, call for service.
INSTALL CYAN TONER CARTRIDGE	The cyan toner cartridge is not installed.	<ol style="list-style-type: none"> 1. Install a cyan toner cartridge. See “Replacing Toner Cartridges” on page 5–4. 2. Print a configuration page (see “Printing a Configuration Page” on page 4–9) and note the print count that it reports. Record this information on your Supplies Replacement Log, shown in Appendix B. 3. If the problem continues, call for service.

Operator Error Messages

Message	Problem	Operator Action
INSTALL FUSER UNIT	The fuser is not installed or is not installed correctly.	<ol style="list-style-type: none"> 1. Install a new fuser. See “Replacing the Fuser” on page 5–19. 2. Make sure that the fuser is secured by tightening the 2 mounting screws. 3. Print a configuration page (see “Printing a Configuration Page” on page 4–9) and note the print count that it reports. Record this information on your Supplies Replacement Log, shown in Appendix B. 4. If the problem continues, install another fuser. 5. If the problem continues after you install another fuser, call for service.
INSTALL MAGENTA TONER CARTRIDGE	The magenta toner cartridge is not installed.	<ol style="list-style-type: none"> 1. Install a magenta toner cartridge. See “Replacing Toner Cartridges” on page 5–4. 2. Print a configuration page (see “Printing a Configuration Page” on page 4–9) and note the print count that it reports. Record this information on your Supplies Replacement Log, shown in Appendix B. 3. If the problem continues, call for service.
INSTALL PHOTO DRUM	The photoconductor drum cartridge is not installed.	<ol style="list-style-type: none"> 1. Install the photoconductor drum cartridge. See “Replacing the Photoconductor Drum Cartridge” on page 5–33. If the drum is installed, make sure that it is installed completely and is latched. 2. Print a configuration page (see “Printing a Configuration Page” on page 4–9) and note the print count that it reports. Record this information on your Supplies Replacement Log, shown in Appendix B. 3. If the problem continues, install another photoconductor drum cartridge. 4. If the problem continues, call for service.
INSTALL YELLOW TONER CARTRIDGE	The yellow toner cartridge is not installed.	<ol style="list-style-type: none"> 1. Install a yellow toner cartridge. See “Replacing Toner Cartridges” on page 5–4. 2. Print a configuration page (see “Printing a Configuration Page” on page 4–9) and note the print count that it reports. Record this information on your Supplies Replacement Log, shown in Appendix B. 3. If the problem continues, call for service.
LOAD LTR PAPER	Load letter-size paper in tray 1 or tray 2.	<ol style="list-style-type: none"> 1. Load letter-size paper in tray 1 or tray 2. See “Loading Paper” on page 3–2. 2. If the problem continues after you load paper, call for service.
LOAD LGL PAPER	Load legal-size paper in tray 1 or tray 2.	<ol style="list-style-type: none"> 1. Load legal-size paper in tray 1 or tray 2. See “Loading Paper” on page 3–2. 2. If the problem continues after you load paper, call for service.
LOAD A4 PAPER	Load A4-size paper in tray 1 or tray 2.	<ol style="list-style-type: none"> 1. Load A4-size paper in tray 1 or tray 2. See “Loading Paper” on page 3–2. 2. If the problem continues after you load paper, call for service.

Operator Error Messages

Message	Problem	Operator Action
LOAD B5 PAPER	Load JIS B5-size paper in tray 1 or tray 2.	<ol style="list-style-type: none"> 1. Load JIS B5-size paper in tray 1 or tray 2. See "Loading Paper" on page 3–2. 2. If the problem continues after you load paper, call for service.
LOAD LTR PAPER AUXILIARY TRAY	The auxiliary tray is out of paper.	<ol style="list-style-type: none"> 1. Load letter-size paper in the auxiliary tray. See "Loading Paper in the Auxiliary Tray" on page 3–6. 2. If the problem continues after you load paper, call for service.
LOAD LGL PAPER AUXILIARY TRAY	The auxiliary tray is out of paper.	<ol style="list-style-type: none"> 1. Load legal-size paper in the auxiliary tray. See "Loading Paper in the Auxiliary Tray" on page 3–6. 2. If the problem continues after you load paper, call for service.
LOAD A4 PAPER AUXILIARY TRAY	The auxiliary tray is out of paper.	<ol style="list-style-type: none"> 1. Load A4-size paper in the auxiliary tray. See "Loading Paper in the Auxiliary Tray" on page 3–6. 2. If the problem continues after you load paper, call for service.
LOAD B5 PAPER AUXILIARY TRAY	The auxiliary tray is out of paper.	<ol style="list-style-type: none"> 1. Load JIS B5-size paper in the auxiliary tray. See "Loading Paper in the Auxiliary Tray" on page 3–6. 2. If the problem continues after you load paper, call for service.
LOAD LTR PAPER IN TRAY 1	Tray 1 is out of paper.	<ol style="list-style-type: none"> 1. Load letter-size paper in tray 1. See "Loading Paper" on page 3–2. 2. If the problem continues after you load paper, call for service.
LOAD LGL PAPER IN TRAY 1	Tray 1 is out of paper.	<ol style="list-style-type: none"> 1. Load legal-size paper in tray 1. See "Loading Paper" on page 3–2. 2. If the problem continues after you load paper, call for service.
LOAD A4 PAPER IN TRAY 1	Tray 1 is out of paper.	<ol style="list-style-type: none"> 1. Load A4-size paper in tray 1. See "Loading Paper" on page 3–2. 2. If the problem continues after you load paper, call for service.
LOAD B5 PAPER IN TRAY 1	Tray 1 is out of paper.	<ol style="list-style-type: none"> 1. Load JIS B5-size paper in tray 1. See "Loading Paper" on page 3–2. 2. If the problem continues after you load paper, call for service.
LOAD LTR PAPER IN TRAY 2	Tray 2 is out of paper.	<ol style="list-style-type: none"> 1. Load letter-size paper in tray 2. See "Loading Paper" on page 3–2. 2. If the problem continues after loading paper, call for service.
LOAD LGL PAPER IN TRAY 2	Tray 2 is out of paper.	<ol style="list-style-type: none"> 1. Load legal-size paper in tray 2. See "Loading Paper" on page 3–2. 2. If the problem continues after you load paper, call for service.
LOAD A4 PAPER IN TRAY 2	Tray 2 is out of paper.	<ol style="list-style-type: none"> 1. Load A4-size paper in tray 2. See "Loading Paper" on page 3–2. 2. If the problem continues after you load paper, call for service.

Operator Error Messages

Message	Problem	Operator Action
LOAD B5 PAPER IN TRAY 2	Tray 2 is out of paper.	<ol style="list-style-type: none"> 1. Load JIS B5-size paper in tray 2. See "Loading Paper" on page 3-2. 2. If the problem continues after you load paper, call for service.
LOAD LETTER TRANSP. AUXILIARY TRAY	The auxiliary tray is out of transparencies.	<ol style="list-style-type: none"> 1. Load letter-size transparencies in the auxiliary tray. See "Loading Paper in the Auxiliary Tray" on page 3-6. 2. If the problem continues after you load transparencies, call for service.
LOAD A4 TRANSP. AUXILIARY TRAY	The auxiliary tray is out of transparencies.	<ol style="list-style-type: none"> 1. Load A4-size transparencies in the auxiliary tray. See "Loading Paper in the Auxiliary Tray" on page 3-6. 2. If the problem continues after you load transparencies, call for service.
OFFLINE	This is an informational message, unless the message does not change.	<ol style="list-style-type: none"> 1. If the message does not clear, turn the printer off and on. 2. If the problem continues, call for service.
PAPER JAM PAPER TOO LONG	Paper length goes above the maximum of 14 inches.	<ol style="list-style-type: none"> 1. Clear the jam and reset the printer (see "Clearing Paper Jams" on page 6-3). 2. If the problem continues after clearing the paper jam, call for service.
PAPER JAM AREA 3 OPEN FRONT DOOR	Paper is jammed in the feeder access area. The paper did not reach the preregistration sensor or the leading edge sensor in time.	<ol style="list-style-type: none"> 1. Clear the jam and reset the printer (see "Clearing Paper Jams" on page 6-3). 2. If the problem continues after clearing the paper jam, call for service.
PAPER JAM AREA 2 OPEN FRONT DOOR	Paper has jammed in the fuser area. Paper did not reach the delivery sensor in time.	<ol style="list-style-type: none"> 1. Clear the jam and reset the printer (see "Clearing Paper Jams" on page 6-3). 2. If the problem continues after clearing the paper jam, call for service.
PAPER JAM AREA 1 OPEN FRONT DOOR	Paper was not detected on the transfer drum or did not separate from the transfer drum correctly. The paper was not detected by the separation sensor.	<ol style="list-style-type: none"> 1. Clear the jam and reset the printer (see "Clearing Paper Jams" on page 6-3). 2. If the problem continues after removing the paper jam, call for service.
POWER SAVER MODE	This is an informational message, unless the message does not change.	<ol style="list-style-type: none"> 1. If the message does not clear, turn the printer off and on. 2. If the problem continues, call for service.
PRINTING	This is an informational message, unless the message does not change.	<ol style="list-style-type: none"> 1. If the message does not clear, turn the printer off and on. 2. If the problem continues, call for service.

Operator Error Messages

Message	Problem	Operator Action
PROCESSING	This is an informational message, unless the message does not change.	<ol style="list-style-type: none">1. If the message does not clear, turn the printer off and on.2. If the problem continues, call for service.
REPLACE USED TONER BOTTLE	The used toner bottle is full.	<ol style="list-style-type: none">1. Replace the used toner bottle. See "Replacing the Used Toner Bottle" on page 5–14.2. If the problem continues, call for service.
WARMING UP	This is an informational message, unless the message does not change.	<ol style="list-style-type: none">1. If the message does not clear, turn the printer off and on.2. If the problem continues, call for service.

Chapter 8. Maintaining the Printer

This chapter tells you how to clean the printer and do routine maintenance tasks. Regular cleaning and maintenance (as needed) and careful handling of the printer keep the printer and print quality in the best condition.

This chapter covers the following topics:

Cleaning the Outside of the Printer	8-2
Cleaning the Paper Path	8-3
Cleaning the Paper Feeder Area	8-3
Cleaning the Transfer Drum	8-3
Cleaning the Separation Corona Wire	8-3
Cleaning the Window of the Density Detection Sensor	8-4
Cleaning the Fuser Rollers	8-5
Replacing the Air and Ozone Filters	8-6
Replacing the Separation Corona Unit	8-10
Replacing the Transfer Drum Cleaning Assembly	8-12

Cleaning the Outside of the Printer

This section tells you how to clean the outside of the printer.



<2-1> CAUTION:

Switch off printer power and unplug the power cord from the power receptacle.

Use a soft cloth slightly moistened with water or a mild detergent solution to clean the outside of the printer. Do not use any other type of solvents, such as alcohol, benzine, or any spray that might damage the finish. When you finish cleaning, wipe the cabinet with a dry cloth.

During the cleaning process, some toner may float in the air inside the printer. For a more thorough cleaning, wait a few minutes to let the toner settle and then clean again.

Cleaning the Paper Path

This section tells you how to clean the paper path areas in the printer.



<2-1> CAUTION:

Switch off printer power and unplug the power cord from the power receptacle.

Cleaning the Paper Feeder Area

Paper dust may collect inside the paper feeder area and affect print quality. Periodically wipe off the paper feeder area with a soft, clean cloth moistened with water. After that, wipe any water residue off with a soft, clean, dry cloth. It might help to use a small vacuum cleaner to do this. To open the paper feeder, see “Clearing a Paper Jam in Area 3 (Paper Feeder Area)” on page 6–9.

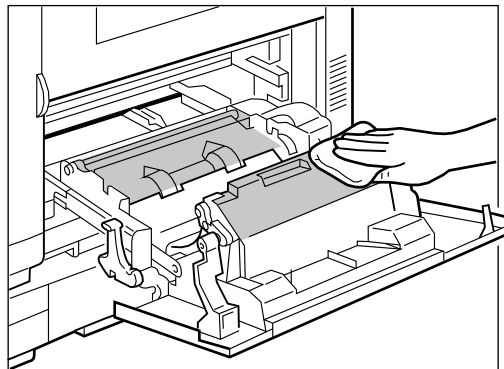

Cleaning the Transfer Drum

Clean the surface of the transfer drum only when it is very dirty. Wipe the surface gently with a lint-free cloth. Do not use water or solvents. Do not touch the surface with your hand. Be careful not to spill solvents or oil on the surface.

To access the transfer drum, see “Clearing a Paper Jam in Area 1 (Transfer Drum Area)” on page 6–4.

Cleaning the Separation Corona Wire

When you replace the photoconductor drum cartridge or if you see toner spots on your printouts, clean the separation corona wire using the procedure under “Cleaning the Separation Corona Wire” on page 5–39.

Cleaning the Window of the Density Detection Sensor

When there is a density detection error, or if the window of the density detection sensor is soiled with toner residue or dust, use the following procedure to clean the window.

1. Turn off the printer. Open the front door and top cover to see the window of the density detection sensor.

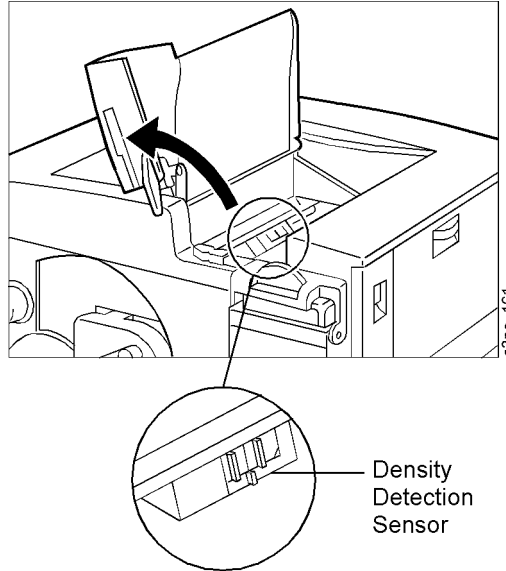

2. Remove the wire cleaner from inside the printer.

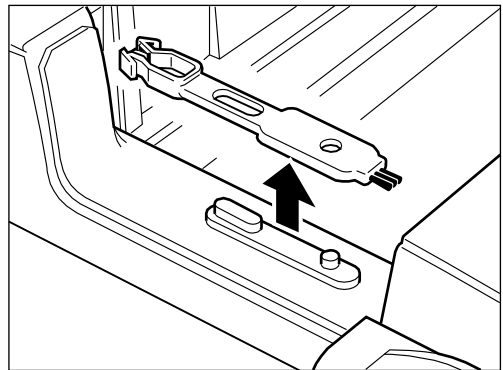

3. Put the brush end of the wire cleaner on the window surface as shown.

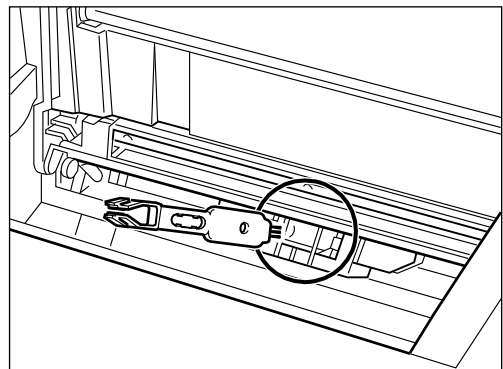

4. Clean the surface with the brush and remove any dirt.

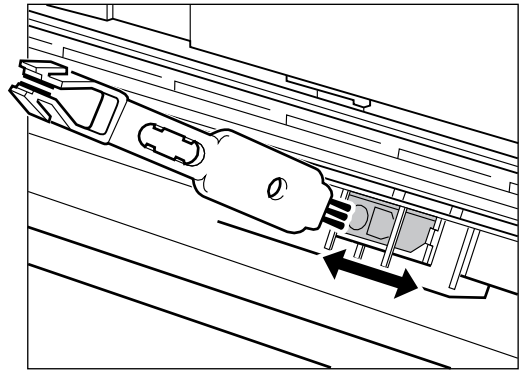

5. After you clean the window, replace the wire cleaner in its storage place and close the top cover and the front door. Turn on the printer to resume printing.

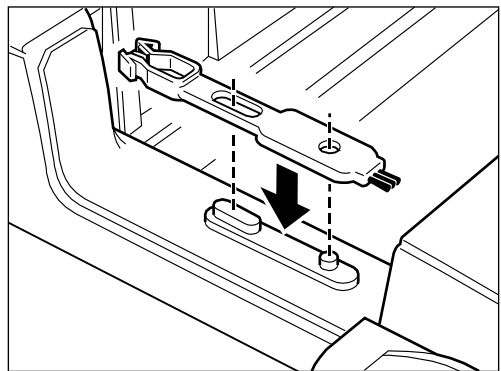

Cleaning the Fuser Rollers



<2-6> CAUTION:

High temperature. Switch off printer power and allow at least 15 minutes for parts in this area to cool before handling.

Use a lint-free cloth to gently wipe the fuser rollers. This removes any toner residue, dust, or lint.

Replacing the Air and Ozone Filters

This section guides you through the following procedures:

- Replacing the air filter
- Replacing the ozone filter

You should replace the air and ozone filters every 60 000 prints. Replacement filters are part of the 60 000-page usage kit.

Use the following procedure to replace the air and ozone filters.

1. Remove the used air filter.
 - a. Using the ridged grip on the top of the air filter holder [1], pull the holder out as shown.

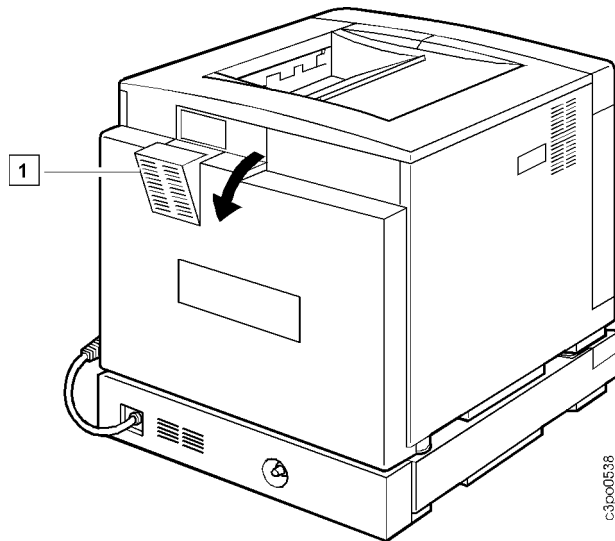

- b. Position the inside of the holder so that it is facing you.
- c. Push up on the filter as illustrated to pop the filter [2] out of the holder [1].

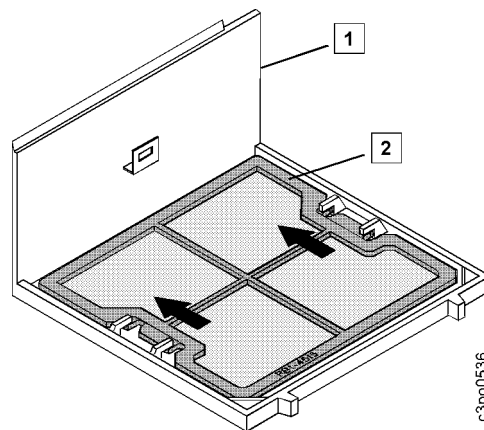

2. Install the new air filter.
 - a. Position the new filter with the embossed side (the side with the serial number) facing you.
 - b. Push down on the filter [2] as illustrated to slide it under the retaining clips on the holder [1].

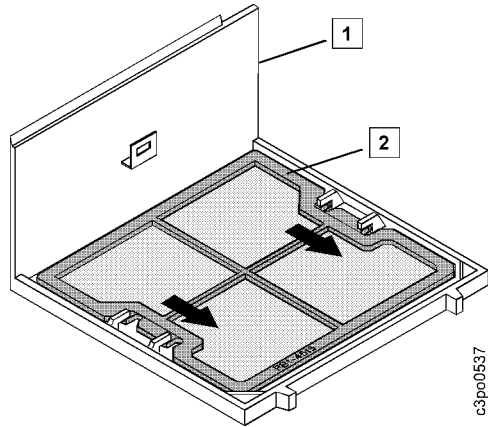

3. Replace the ozone filter.

- a. Grasp the tab [1] on the ozone filter [2], and pull the used filter up and out of the holder [3].

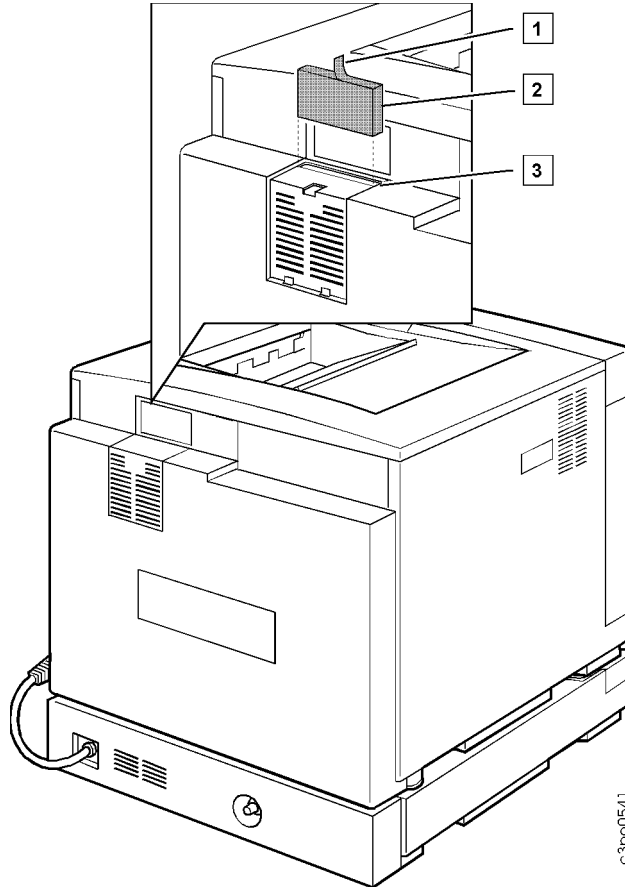

- b. Hold the tab [1] on the new ozone filter [2] and lower the filter into the holder [3] as shown in the illustration above.

4. Reposition the filter holder.
 - a. Align the holder [1] so that the pegs on the bottom of it fit in the holes on the back of the printer.
 - b. Push the holder [1] in until it snaps into place.

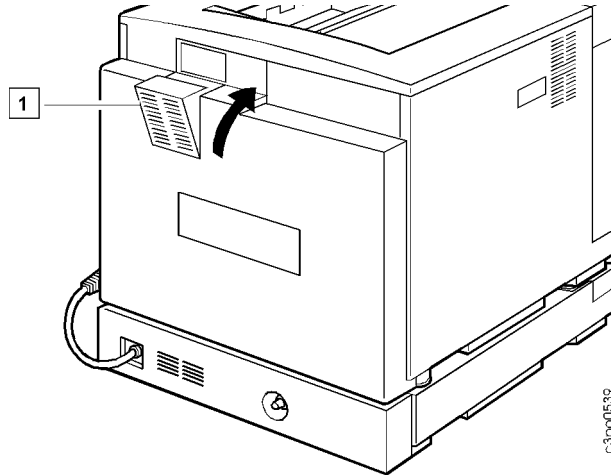

Replacing the Separation Corona Unit

This section tells you how to replace the separation corona unit. You should replace the separation corona unit every 60 000 prints. A replacement unit is part of the 60 000-page usage kit.

Use the following procedure to replace the separation corona unit.

1. Remove the old separation corona unit.
 - a. Turn off the printer, and open the front door and top cover to see the separation corona unit [1].
 - b. Use one hand to hold the top cover down slightly for better access to the separation corona unit.
 - c. Squeeze together the 2 green tabs on the handle of the unit [2]. Slide the unit to the back of the printer, as indicated by the arrow on the separation corona unit.

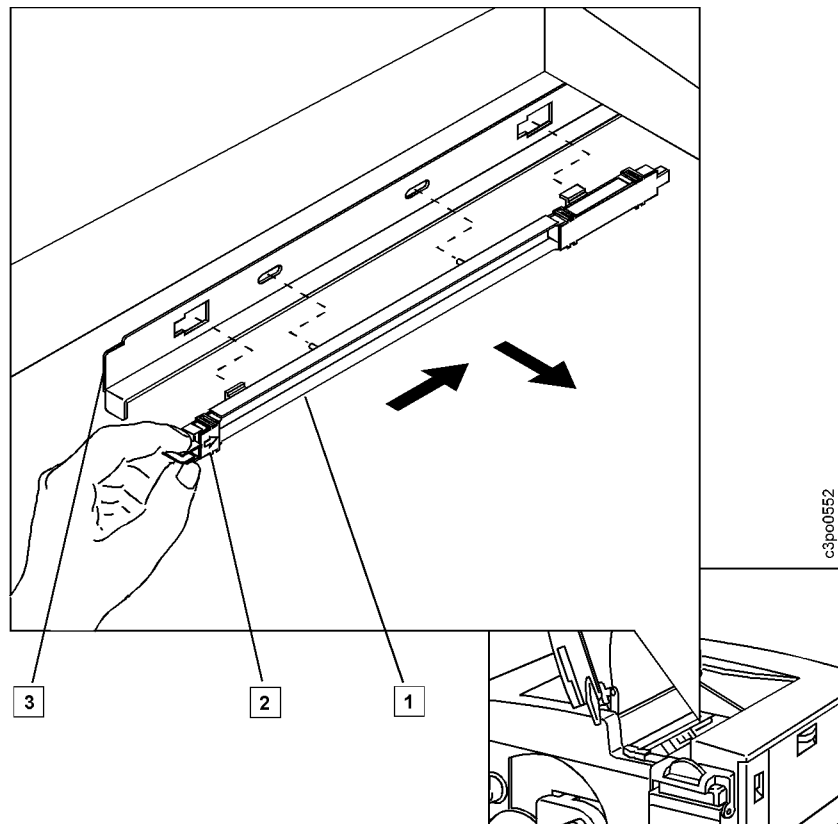

- d. Pull the unit away from the plate [3].

2. Install the new separation corona unit.

- a. Align the 2 locking tabs on the separation corona unit [1] with the keyholes cut out of the plate [3]. (It helps to hold the top cover down slightly for better access to the separation corona unit.)

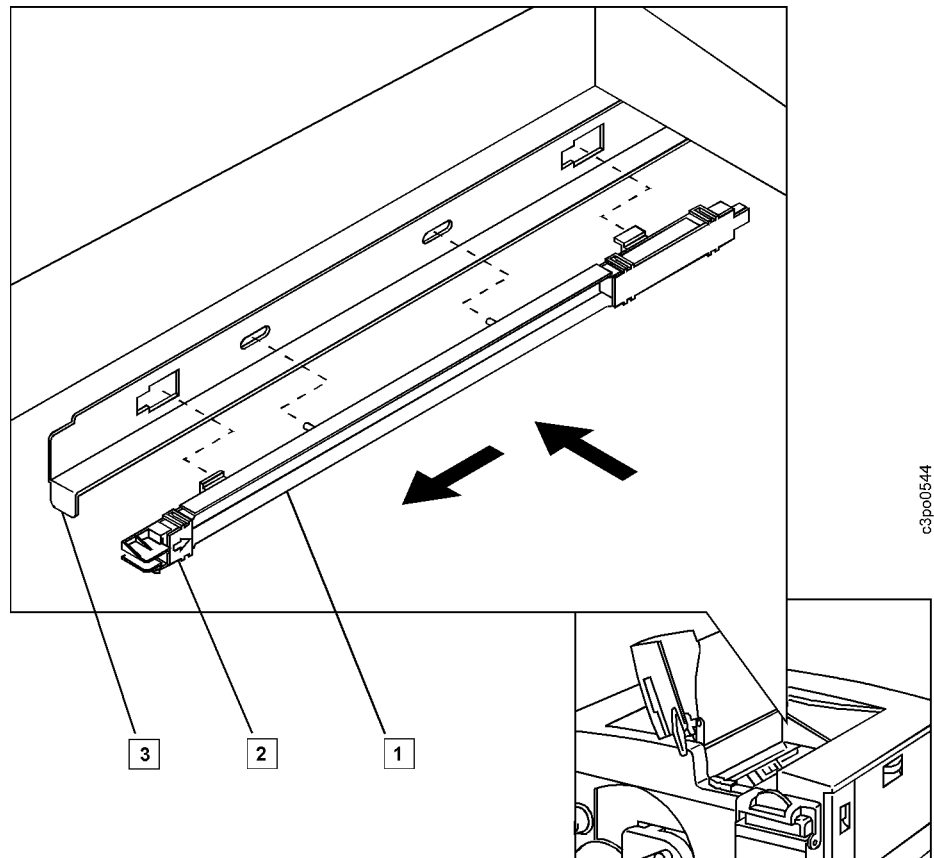

- b. Push the separation corona unit against the plate so that the tabs are inserted into the keyholes, as illustrated above.
- c. Being careful not to touch the separation corona wire, use the handle [2] to slide the separation corona unit to the front of the printer. Each tab locks into the narrow end of its keyhole.
- d. Make sure that the separation corona unit is firmly attached to the plate. If it is not, repeat step 2a through step 2c.
- e. Close the top cover and front door.

Replacing the Transfer Drum Cleaning Assembly

This section tells you how to replace the transfer drum cleaning assembly. You should replace the transfer drum cleaning assembly every 60 000 prints. A replacement assembly is part of the 60 000-page usage kit.

Use the following procedure to replace the transfer drum cleaning assembly.

1. Pull the paper feeder out.
 - a. Turn off the printer and unplug the power cord from the wall receptacle.
 - b. Make sure the auxiliary tray is closed. It must be closed to open the feeder access door.

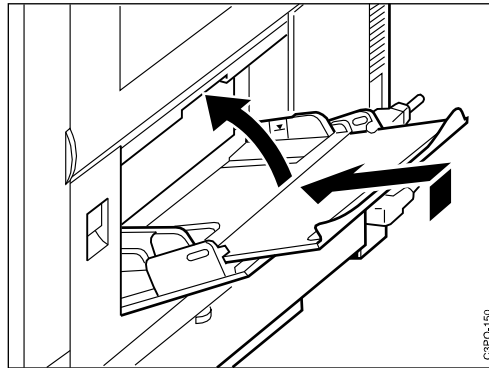

- c. Push up the release latch to open the feeder access door completely.

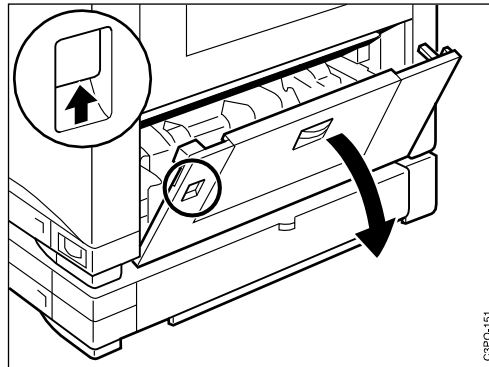

- d. Pull on the 2 green levers to slide out the paper feeder.

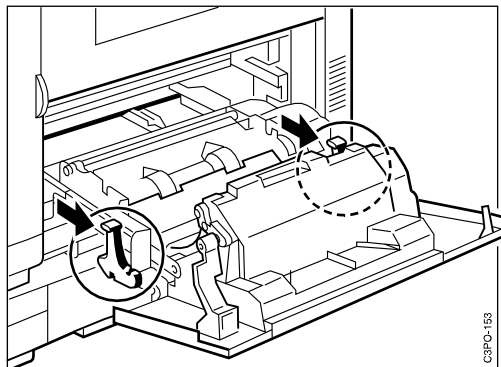

2. Remove the cleaning connector cover.
 - a. Push in the tab [2] on the front of the connector cover [3] to disengage it from its slot [1].
 - b. Pivot the cover to the front of the printer and disengage the rear clip [4] from its slot [5]. You may have to move the cover from side to side several times to disengage the clip. Be careful not to break the clip.
 - c. Unplug the connector [6] by pulling on the wires (not by pulling on the white connector).

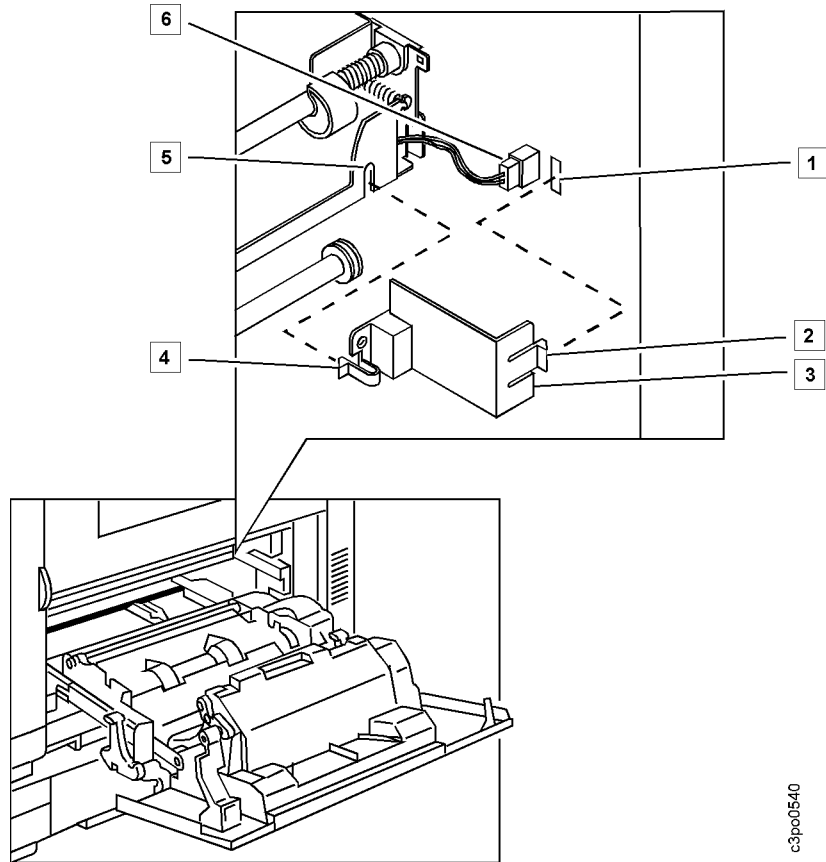

c3po0540

3. Remove the used transfer drum cleaning assembly.

Attention:

When you remove or install the transfer drum cleaning assembly, do not damage the Mylar strip on the top left of the assembly.

- a. Pull the lever on the cleaning assembly [1] slightly toward you and up.
- b. Pivot the transfer drum cleaning assembly toward you, using the aligning shaft [2] to guide the cleaning assembly along the slot [3]. Hold the cleaning assembly firmly and lift it toward you and out of the printer.

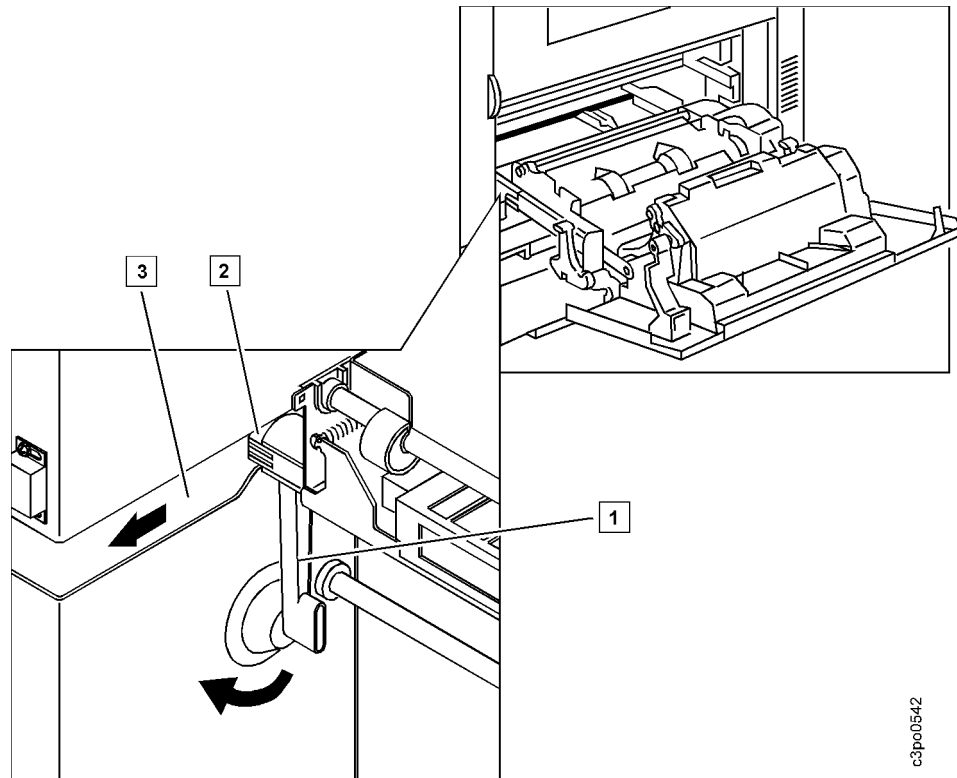

c3po0542

4. Install the new transfer drum cleaning assembly.
 - a. Position the cleaning assembly lever so that it is pointing straight toward you.
 - b. Find the 2 tapered guide pins [1] on the transfer drum cleaning assembly [3]. Align and insert the guide pins in the 2 holes [2].

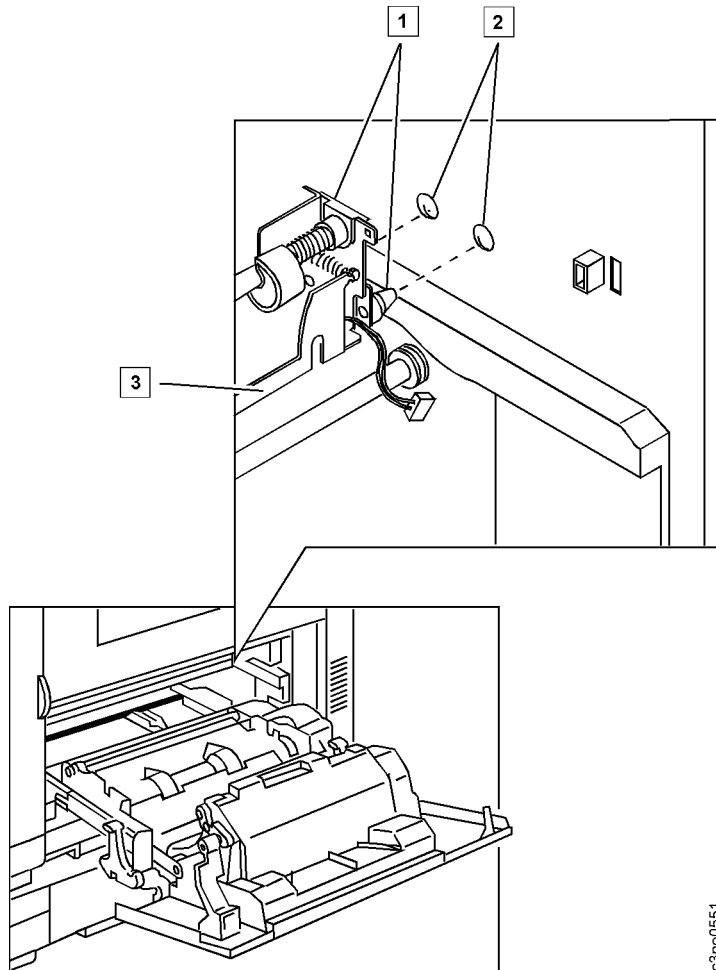

- c. Put the aligning shaft [3] in the slot [1]. Pivot the transfer drum cleaning assembly away from you along the slot.

e3pc0551

d. Push the cleaning assembly lever [2] down until it locks into place.

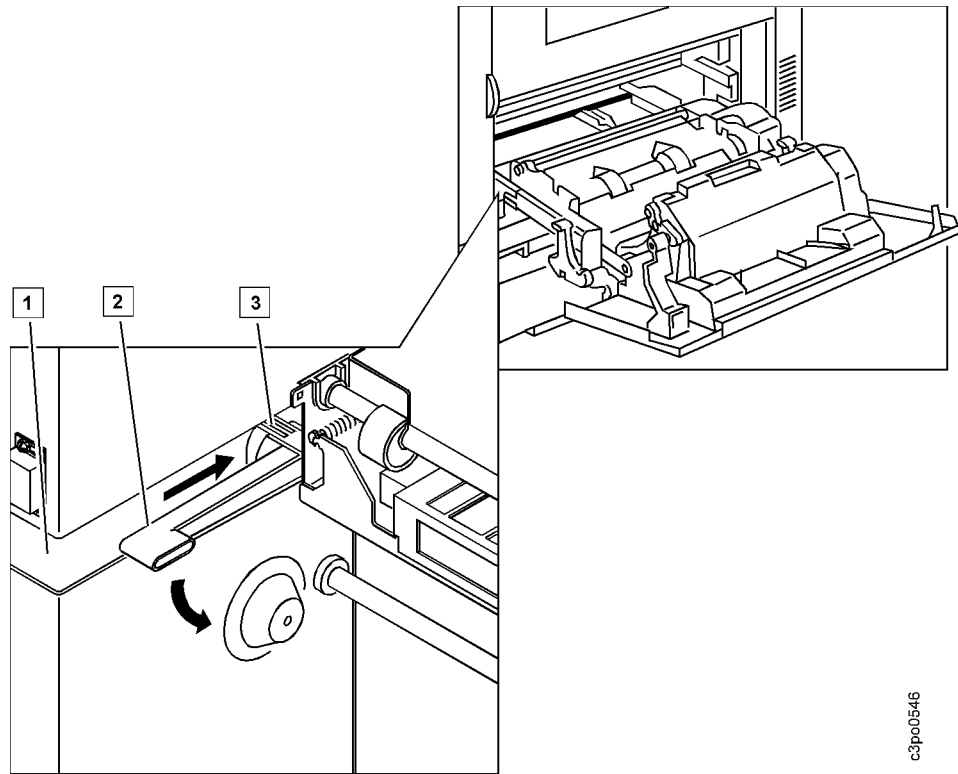

c3pc0546

5. Replace the cleaning connector cover.
 - a. Plug the cleaning connector [5] into the socket [6].
 - b. Insert the clip [3] into the slot [4].
 - c. Pivot the cover toward the back of the printer.
 - d. Align the tab [2] with the slot [1] and push it in until it locks.

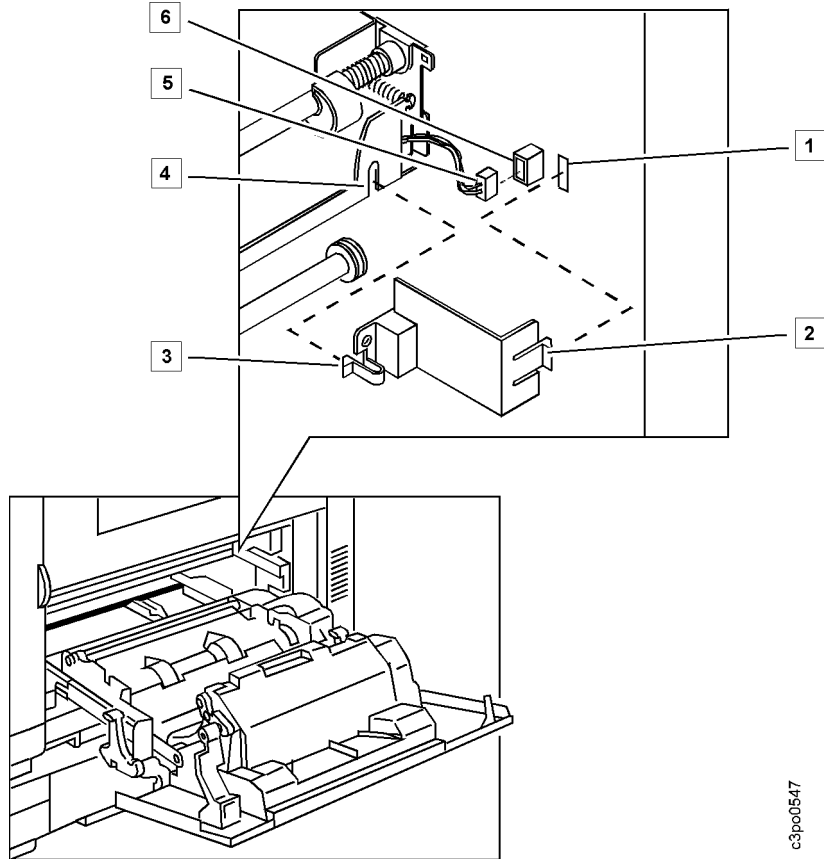

c3po0547

6. Slide the paper feeder back into the printer.

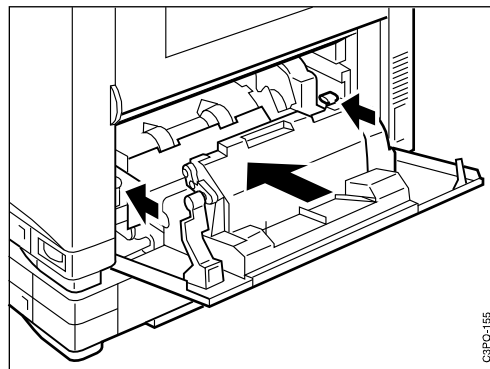

C3PO-155

7. Close the feeder access door.

Appendix A. Help Map

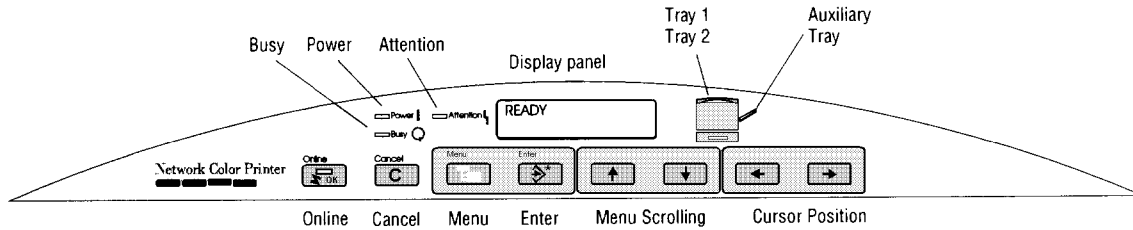

Button functions

		When printer is online	During Setup
Online		Toggles to take printer on and off the network	None
Cancel		Stops printing the current job, if any	None
Menu and Enter		Menu displays the Print Pages menu. When offline or during powerup, starts Setup In Print Pages menu, Enter selects current choice and proceeds. When Attention light is flashing, displays any warning message. Then toggles between status and warning message.	Menu displays previous level in menu. At top level, prompts to exit Setup Enter selects menu or accepts menu item or setting and proceeds to next item
Menu Scrolling		In Print Pages menu, Menu scrolling keys display other pages. If Attention is flashing, and + appears at right of display panel, they display additional warning message(s).	Scroll to display menu items or settings.
Cursor Position		None	Backspace or advance cursor for text entry

Tray 1
Tray 2
Auxiliary Tray



Power light indicates that printer is getting power



Attention light alerts you to check the display panel for error or warning message. Pressing Enter displays warning message.



Busy light indicates that printer is processing or printing a job



Online light is lit when printer is online to the network, flashing when offline is pending, and off when printer is offline

Offline menus—Language and Setup menus

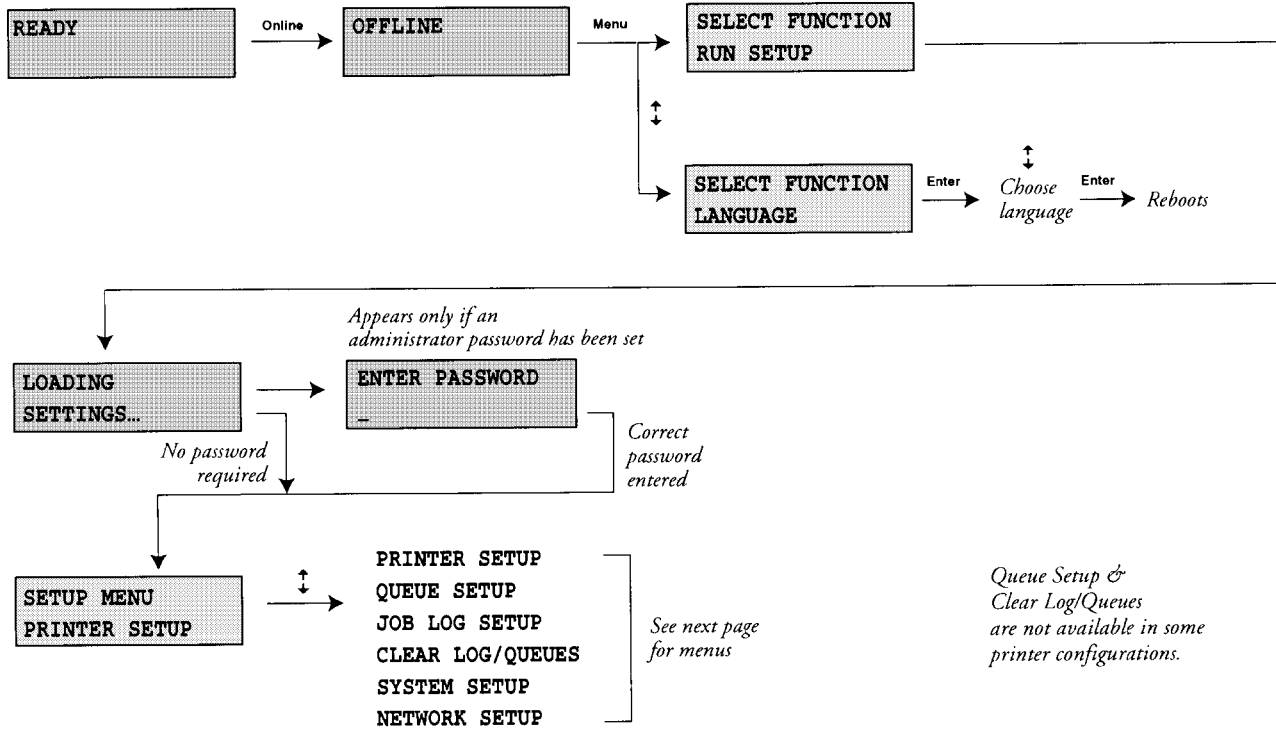

Online menu—Print Pages

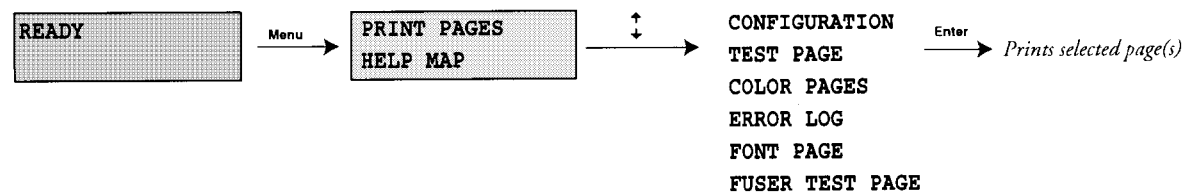

Booting up

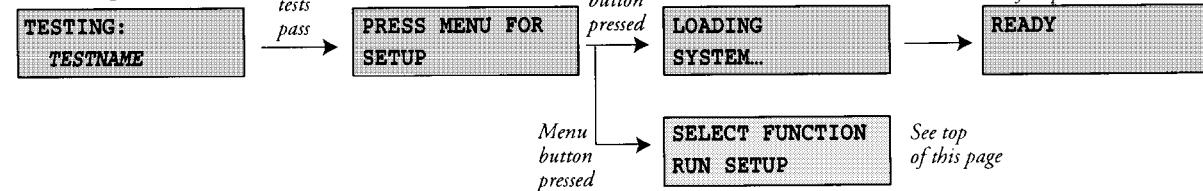

c3pm0302

Setup menus

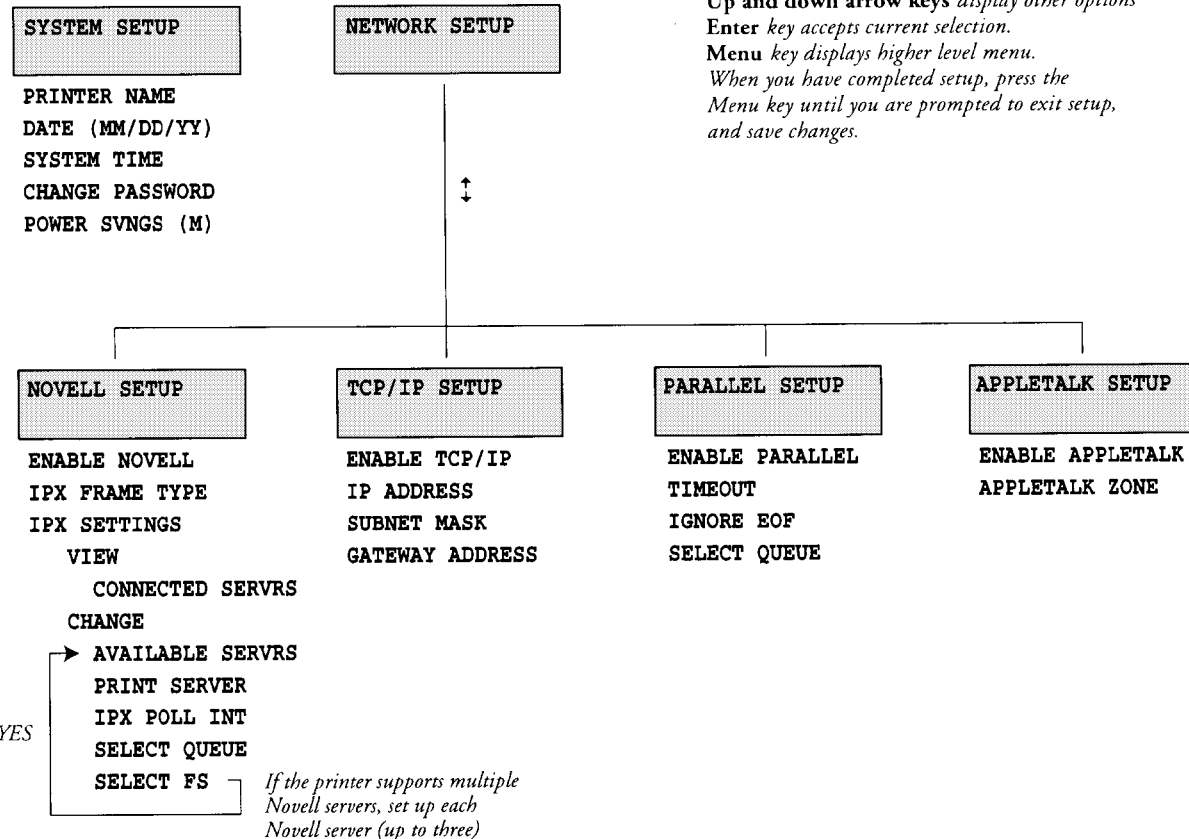
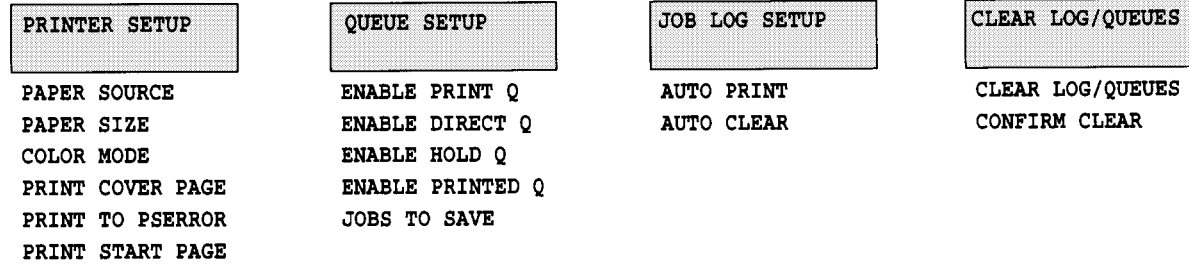

c3pm0303



Appendix B. Supplies Replacement Log

We recommend that you make a photocopy of the log on the next page. When you replace one of the listed supplies, use the photocopy to record the date and print count. Print a Configuration page to get the print count (see "Printing a Configuration Page" on page 4–9).

Supplies Replacement Log

Toner—Cyan

Print Count						
Date						
Print Count						
Date						

Toner—Magenta

Print Count						
Date						
Print Count						
Date						

Toner—Yellow

Print Count						
Date						
Print Count						
Date						

Toner—Black

Print Count						
Date						
Print Count						
Date						

Photoconductor Drum Cartridge

Print Count						
Date						
Print Count						
Date						

Fuser Oil Bottle

Print Count						
Date						
Print Count						
Date						

Fuser

Print Count						
Date						

Appendix C. Wiring Diagrams

These wiring diagrams are for service use only.

General Circuit Diagram (2 of 2)

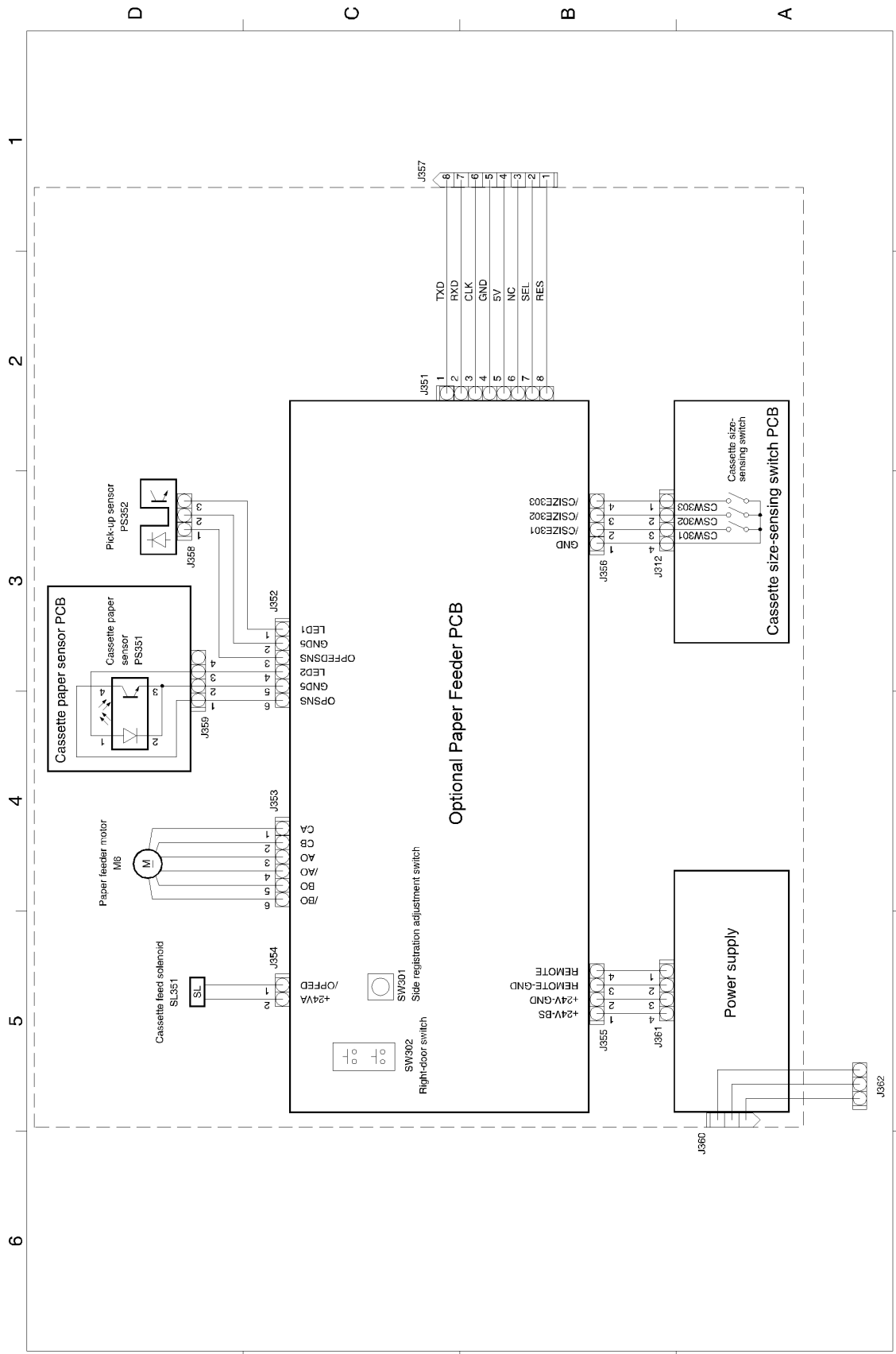

C3PM0123

Acronyms and Abbreviations

ac	alternating current	HVT	high-voltage transformer
ADB	Apple Desktop Bus	Hz	herz
AIX	Advanced Interactive Executive	IC	integrated circuit
ANSI	American National Standards Institute	I/O	input/output
APC	automatic photoemission control	ipm	impressions per minute
C	centigrade	IPX	Internet package exchange
CCITT	Comité Consultatif International Télégraphique et Téléphonique	IPX/SPX	Internet packet exchange/sequenced packet exchange
CCW	channel command word	ISO	International Organization for Standardization
CD-ROM	compact disk read-only memory	JIS	Japanese Industry Standard
CE	customer engineer	K	kilo
CPU	central processing unit	KB	kilobyte
CRC	cyclical redundancy check	kg	kilogram
CRD	color-rendering dictionary	laser	light amplification by stimulated emission of radiation
CRT	cathode-ray tube	LED	light-emitting diode
CRU	customer replaceable unit	LGL	legal
dB	decibel	lpi	lines per inch
dc	direct current	LPR	local printer
DEV	developer	LPT	local port
dpi	dots per inch	MB	megabyte
DRAM	dynamic random access memory	mm	millimeter
DTP	desktop publishing	OHP	overhead projection
EBCDIC	extended binary-coded decimal interchange code	OPC	organic photoconductor
EC	engineering change	PC	personal computer, photoconductor
EEPROM	electronically erasable programmable read-only memory	PCB	printed circuit board
EPROM	erasable programmable read-only memory	PDF	printer description file
ERP	error recovery procedure	PEL	pixel
F	Fahrenheit	pixel	picture element
FIFO	first in first out	POST	power-on self-test
FM	fan	ppi	pixels per inch
FRU	field-replaceable unit	ppm	pages per minute
GDI	graphics device interface	RAM	random access memory
GND	ground	RH	relative humidity
GUI	graphical user interface	RIP	raster-image processor
H	fuser heater	RISC	reduced instruction set computer
		ROM	read-only memory

SCSI	small computer system interface
SEF	short edge feed
SIMM	single inline memory module
spool	simultaneous peripheral operations online
TCP/IP	transmission control protocol/Internet protocol
TIFF	tagged image file format
TP	test point
V ac	volts alternating current
V dc	volts direct current

Glossary

The following terms are defined as they are used in this publication. If you do not find the term you need, see the *IBM Dictionary of Computing*, New York, McGraw-Hill, 1994, and the *IBM Dictionary of Printing*, G544-3973.

The following cross-references are used in this glossary:

- *Deprecated term for* refers to a term that should not be used and lists the preferred term.
- *Contrast with* refers to a term that has an opposite meaning.
- *See* refers to a preferred term with the same meaning.
- *See also* refers to related terms.

Numerics

60,000-Page Usage Kit. An air filter, ozone filter, transfer drum cleaning assembly, separation corona unit, and fuser to be installed in the printer by the operator after 60,000 prints. The 60,000-page Usage Kit is available for the low-voltage (110 V) and high-voltage (220 V) models.

A

actuator. A device that initiates mechanical motion.

administrator. See *network administrator*.

Adobe Acrobat Reader. A program used to view the online documentation supplied with the printer.

Adobe Illustrator. A professional illustration program for Macintosh computers and PCs that produces object-oriented images and prints them on PostScript laser printers.

air filter holder. The area on the back of the printer that holds the printer's air filter and gives you access to the printer's ozone filter.

air ventilation system. Horizontal slots on the back and left sides of the printer that prevent

overheating and ensure that the printer works reliably.

AIX operating system. IBM's version of the UNIX operating system.

aliasing. Unwanted effects such as Moiré patterns in an image. These patterns, called artifacts, look like two sets of parallel lines or two halftone screens superimposed.

anti-aliasing. The rendering of hard-edged objects so that they blend smoothly into the background.

Apple Desktop Bus (ADB). An interface standard for connecting a keyboard, mouse, trackball, or other input devices to an Apple Computer Macintosh SE, Macintosh II, or Macintosh IIGS computer.

AppleShare. A network operating system developed by Apple Computer, Inc., that transforms a Macintosh computer into a file server for an AppleTalk network. See also *AppleTalk*.

AppleTalk. A local area network (LAN) standard developed by Apple Computer, Inc. AppleTalk can link as many as 32 Macintosh computers, PCs, and peripherals such as laser printers.

auxiliary tray. A paper feeder tray that holds either 100 sheets of plain paper (at 80 g/m²) or 20 transparencies.

B

banding. Visible steps between shades in a gradient. See also *gradient*.

batch printing. The queuing of one or more documents to print in a separate job as a background process.

bias. An electrical charge applied to a component of the printer such as the toner cartridge, transfer drum, discharge roller, attraction roller, or separation

corona unit. The bias can be ac or dc or a combination of both.

bindery context. An option that allows you to use the printer with Novell NetWare release 4.x. Bindery context is explained in the Novell NetWare documentation.

bindery emulation mode. See *bindery context*.

bitmap. An image formed by a rectangular grid of pixels. Each pixel in the grid is assigned a value to denote its color. 1-bit images are black and white only, 8-bit images are 256 colors or grays, and 24-bit images are full color. CMYK images are 32-bit per pixel to encode 256 levels in each of 4 channels. Also called *raster image*. See also *pixel*, *raster*, *raster image*.

bond. A paper formulated with at least 80% wood pulp. Bond is the best paper to use in the printer.

burr. A thin ridge or area of roughness produced in cutting or shaping metal.

C

calibration. The process of ensuring that a device works consistently according to a set of specifications.

Calibrator utility. See *IBM Color Calibrator*.

cam. A rotating or sliding piece in a mechanical linkage used especially in transforming rotary motion to linear motion and vice versa.

cassette. A deprecated term for tray 1 or tray 2 on the printer. See *universal cassette*.

caution notice. A notice that calls attention to a condition that is potentially dangerous to people.

Chooser. A Macintosh desktop accessory that governs the selection of printer drivers.

cleaning connector cover. The electrical connector cover for the transfer drum cleaning brush.

client. In a local area network (LAN), a workstation with processing capabilities such as a PC that can request information or applications from the network's file server.

CMYK. Cyan, magenta, yellow, and black, the four basic colors used in offset printing, as opposed to red, green, and blue (RGB), the three basic colors of light.

CMYK_REF.PS file. A file consisting of PostScript color pages that enable you to specify percentages of cyan, magenta, yellow, and black and get an exact rendering of those percentages in your document.

coated paper. Paper with a surface coating applied to produce smoothness.

color lights. The lights on the printer's density control panel that turn green when you choose the color next to each light to change the density of that color.

color pages. Pages you can print to see the red, green, and blue (RGB); cyan, magenta, yellow, and black (CMYK); and PANTONE colors available on the printer.

color reference pages. See *color pages*.

color-rendering dictionary (CRD). A feature on PostScript level-2 color printers that gives improved matching between the monitor and printed output. Color-rendering dictionaries are used by the printer's PostScript interpreter when converting RGB data sent to the printer to CMYK data used by the print processor. See also *rendering style*.

color-rendering style. See *rendering style*.

COLOR SELECT push button. A button on the printer's density control panel that you press to choose a color whose density you want to change.

configuration page. A page you can print to see the printer's current server and device configuration.

connector. A means of establishing electrical flow.

consumable supplies. A deprecated term for *supplies*. See *supplies*.

container. An entity in a computer such as a storage area that holds other entities such as files or programs.

control unit. The printed circuit board (PCB) that supplies the printer's connection path to the customer's network. The control unit also gives commands to the print engine dc controller PCB to manipulate the motors, solenoids, and actuators during a print cycle. See also *actuator, solenoid*.

controller. See *control unit*.

corona. See *separation corona*.

cursor-position push buttons. The left and right arrow buttons that you press to enter text and numbers for some menu settings (such as a password or a numeric setting).

customer CD-ROM. A CD-ROM holding the user software for the printer, including the IBM Color Calibrator, Downloader, and Spooler utilities and the PostScript color pages.

customer engineer (CE). An IBM representative who services IBM products at the customer's site.

cutout. An area of the printer that is shaped ("cut out") to hold a connecting mechanism such as a tab on another part of the printer.

D

daemon. A software program that runs unattended.

danger notice. A notice used to call attention to a condition that is potentially deadly or extremely dangerous to people.

dedicated file server. In a local area network (LAN), a file server whose function is to provide services to the users of the network and to run the network operating system.

densitometer. An instrument that measures density according to a specified standard. Status T and XRite densitometers are two such color calibration devices.

density. A precise measurement of the light energy transmitted or reflected by a surface in the presence of a standard light source.

density control panel. The set of controls on the back of the printer that enable you to adjust the

density of any of the four colors: magenta, cyan, yellow, or black.

density detection sensor. A device on the printer containing a light source and a sensor. The density detection sensor measures the specific density of toner applied to known surface to regulate the quantity of toner applied during the print process. The reflectance of light on toner varies with the density and color of that toner. Thus the density detection sensor emits a specific amount of light on a toner patch and estimates the density of the toner patch by the amount of light reflected from the toner patch.

density gauge. A row of indicators on the printer's density control panel. When you make a test print, the indicator on the gauge goes on to confirm the test pattern you chose for the test print: solid colors, solid white, gradient, horizontal lines, vertical lines, or grid pattern. See also *gradient*.

dequeue. To remove items from a queue. Contrast with *queue*.

desktop. In a graphical user interface (GUI), a computer representation of day-to-day work; for example, a desktop with open file folders.

desktop publishing (DTP). The use of a PC or other platform as an inexpensive production system for generating typeset-quality text and graphics.

dialog box. In a graphical user interface (GUI), an on-screen message box that interacts with the user to convey or request information. See also *graphical user interface (GUI)*.

diagnostic mode. A mode of operation in which the printer can check itself in case of a problem.

Direct queue. A storage area for the printer that supplies a direct connection to the printer. When you submit a job to the Direct queue, the printer accepts the job when it is ready to print the job. Jobs in the Direct queue are not stored on the printer's hard disk and are not spooled. See also *Hold queue, Print Queue, Printed queue, spooling*.

discharging. The application of ac bias by the printer's discharge roller to remove any charges remaining on the transfer drum surface after separation of the paper.

diskette. A thin, flexible, magnetic disk enclosed in a protective jacket.

display panel. The area on the printer where information such as error messages is displayed.

dots per inch (dpi). The number of dots that can be printed per inch by a laser printer. Each dot is either on or off, printed or not printed. See also *pixels per inch (ppi)*.

Downloader utility. See *IBM Color Downloader*.

driver. A disk file that holds information needed to operate a peripheral such as a computer monitor or printer.

duplex printing. Printing or reproducing a document on both sides of the page so that the verso (left) and recto (right) pages face each other after the document is bound.

E

electrostatic latent image. The image formed on the photoconductor drum surface by a negative charge where the laser beam has not irradiated.

encapsulated PostScript. Any file containing the PostScript page-description language that conforms to Adobe 2.0 document-structuring conventions and the Adobe conventions that allow the file to be included by other applications.

end user. A person, device, program, or computer system that uses a computer network for data processing and information exchange.

enqueue. To put items in a queue. Contrast with *dequeue*.

error log. A file in the printer that stores error messages for later access.

error message. An operator message that you see on the display panel and that causes the **Attention** light to flash. Error messages are listed in the *Operator's Guide*.

NETCHOSTS file. A file that allows you correlate TCP/IP addresses with the names of the devices (such as printers, workstations, and PCs) those addresses represent. See also *TCP/IP*.

Ethernet. A 10-megabit, baseband local area network (LAN) that allows multiple stations to access the transmission medium at will without previous coordination, avoids contention by using carrier sense and deference, and resolves contention by using collision detection and transmission.

F

feeder. See *paper feeder*.

feeder access door. A door on the upper right side of the printer that gives you access to the paper feeder area to remove jammed paper, do maintenance tasks, or replace the transfer drum cleaning unit.

feeder access door on tray 2 paper feeder. A door on the optional tray 2 paper feeder that gives you access to the tray 2 paper feeder area to remove jammed paper.

file server. In a local area network, a PC that provides access to files for all the workstations in the network.

folder. A file used to store documents electronically.

font. A family of characters of a given size and style.

format. The size, style, kind of page, margins, printing needs, and other aspects of a printed page.

frame. The bits in a packet that are assigned to control and synchronize data transfer over a network. See also *packet*.

fuser. The part of the printer that uses heat and pressure to embed toner into the fibers of paper and make a permanent bond.

fuser access door. A door on the upper right side of the printer that gives you access to the paper output area to remove jammed paper and replace the fuser.

fuser access strap. A strap on the fuser access door that is attached to the upper locking tab on the printer's frame to keep the door from dropping down when you open it.

fuser cleaning belt. Part of the mechanism on the fuser cleaning unit that cleans the fuser upper roller.

fuser jam-release lever. A lever to the right of the paper guide inside the printer that is used to pump fuser oil from the oil bottle and to free jammed paper in the fuser area.

fuser nip width check. A procedure done by the customer engineer (CE) to get a specific measurement that shows if the right fuser roller pressure is supplied during the fusing process.

fuser oil. Oil that helps the release of paper from fuser rollers.

fuser oil bottle. A bottle inside the front door of the printer that holds the fuser oil. See also *fuser oil*.

fuser rollers. The hardware devices used to transfer the heat and pressure needed for the toned image on the paper during the fusing process.

fuser slide plate. A metal plate in the printer onto which you slide a fuser when installing it in the printer.

G

gateway address. The computer location of a device that connects two dissimilar local area networks (LANs) or that connects a LAN to a wide area network (WAN), minicomputer, or mainframe.

gradient. A test print that shows an image with multiple stripes that begin in full color on one end and gradually reduce the color content to nearly zero so that only the white paper is visible on the other end.

graphical user interface (GUI). A design for the part of a software program that interacts with the user and takes advantage of the bitmapped graphics displays of PCs. A GUI uses pull-down menus, dialog boxes, icons, and a variety of visually attractive on-screen typefaces. See also *icon*.

graphics device interface (GDI). The graphics and display technology used on computers running the Windows operating system. GDI is the equivalent of the PostScript language that sends words and pictures to the printer.

grayscale. A series of shades from white to black.

H

halftone. A printing method that simulates continuous-tone shading using dots of varying sizes laid out on a regular grid. Larger dots simulate darker tones and vice versa.

help map. A document you can print to guide you to the printer's operator panel, push buttons, and panel lights. The help map lists the menus and tells you how to access each menu.

Hold queue. A job storage area for the printer. When you submit a job to the Hold queue, the printer gets the job immediately and stores it on the hard disk. Jobs in the Hold queue do not print or clear from the printer until someone uses the IBM Color Spooler to move them to the Print queue or to discard them from the printer's hard disk. See also *Direct queue*, *Print queue*, *Printed queue*, *spooling*.

I

IBM Color Calibrator. A software utility program that enables you to keep the printer's colors at a consistent performance level across time.

IBM Color Downloader. A software utility program that enables you to print PostScript and encapsulated PostScript files directly to the printer without using the application in which the files were created. Printing with the Downloader is faster than printing from applications and also enables you to manage the printer fonts installed on the printer.

IBM Color Spooler. A software utility program that enables you to view the order and priority of print jobs, customize printer settings for jobs, delete jobs, and move jobs between queues. You can also use the Calibrator to see a list of the jobs the printer has finished.

icon. In a graphical user interface (GUI), an on-screen symbol that represents a function or resource of the software program or computer hardware. See also *graphical user interface (GUI)*.

ISO sizes. A set of paper sizes used in data processing and chosen from paper sizes that are standardized by the International Organization for Standardization (ISO).

Internet. A wide area network (WAN) connecting thousands of disparate networks in business, technology, education, government, entertainment, and research. The Internet uses the TCP/IP as the standard for transmitting information. See also *TCP/IP*.

Internet address. The numbering system used in TCP/IP internetwork communications to specify a network or host computer on a network. See also *TCP/IP*.

J

jam. See *paper jam*.

job. The result of a command to desktop publishing software to print a document. The PostScript language allows for single PostScript files holding multiple jobs and single jobs spread over multiple files.

job log. A list of the printer's last 40 jobs. The job log includes information such as user name, document name, time and date printed, and number of pages printed for each job.

jumper. A short wire used to close a break or cut out part of a circuit.

K

kilobyte (KB). 1024 bytes.

L

landscape orientation. Text and images that are printed parallel to the longer side of the paper. Contrast with *portrait orientation*.

laser (light amplification by stimulated emission of radiation). A device that emits a beam of coherent light.

laser diode. A laser that uses a forward-biased semiconductor junction as the active medium.

laser interlock. The mechanical blockage of the laser beam when the printer's front door is open. The front door panel has a plastic protrusion that fits into an opening in the printer and mechanically forces the interlock open.

latent toned image. See *electrostatic latent image*.

lens. A piece of transparent material such as glass that has two opposite regular surfaces, either both curved or one curved and the other flat. A lens is used either singly or combined in an optical instrument for forming an image by focusing rays of light.

local area network (LAN). A network of workstations within a limited area connected by high-performance cables so that users can exchange information, share peripherals such as printers, and have access to the resources of a secondary storage unit called a *file server*. See also *file server*.

M

megabyte (MB). 1,024,000 bytes.

menu-scrolling push buttons. The up and arrow buttons that you press to scroll through the menus on the printer's display panel.

microcode. The microprogramming stored on a microcode diskette. Microcode is used by the controller to manage the printer and its functions.

Microsoft Excel A graphics-oriented spreadsheet program developed by Microsoft Corporation for IBM PC-compatible computers and Macintosh computers.

monitor style. A rendering style that produces color similar to the color on a computer monitor. See also *photographic style*, *presentation style*, and *solid-color style*.

multifeed. A condition in which more than one sheet of paper at a time is inserted into the printer's feed roller. A multifeed prevention mechanism on the printer separates the extra sheets to correct the condition.

N

named color. A color that is defined according to a custom color system. For example, PANTONE 107C is a named color.

native file format. The default file format an application uses to store data on disk.

NET_WSCK.INI file. A file used by the utilities running over the TCP/IP and IPX/SPX protocols to find printers on the network.

network administrator. In a local area network (LAN), the person responsible for maintaining the network and helping its users.

Novell NetWare. A network operating system for 80286- and 80386-based DOS computers.

NuBus. Apple Computer's hardware standard for expansion cards.

O

offset. An unintentional transfer of ink such as from a freshly printed page.

operating environment. The physical environment of the printer; for example, temperature, humidity, layout, and power source.

operator panel. The area on the front of the printer with lights, push buttons, and a display panel that help you use the printer.

optical character recognition (OCR). The conversion of scanned text to editable ASCII characters using optical recognition software.

optional tray 2 paper feeder. A tray for feeding paper to the printer that comes with a universal cassette and two locking pins to fasten it to the printer. See also *universal cassette*.

P

packet. A block of data bytes that contains a header, data, and a trailer. The format of a packet depends on the network protocol used to transfer the data. See also *frame*.

PageMaker. A popular page layout program for Windows and Macintosh computers typically used for generating documents such as newsletters, brochures, reports, and books.

paper-amount indicator. A blue bar on the front of the printer below the front door. When the blue

bar has completely disappeared, it is time to add paper to the tray.

paper feeder. The mechanism that inserts paper into the printer.

paper guides. Guides on the auxiliary tray that adjust the width of the tray to fit the paper, and guides on the paper feeder trays that adjust both the width and the length of the tray to fit the paper.

paper jam. A condition in which paper wedged into the paper path prevents the printer from working.

paper path. The entire route that paper travels through the printer during processing.

paper-size indicator. A bar on the front of the printer that tells you the size of the paper in the printer.

PANTONE Matching System. A standard color-selection system for professional color printing that works with high-end illustration programs like Adobe Illustrator and PageMaker 4.0.

PANTONEC.PS. A PANTONE coded file that allows you to choose a named PANTONE color for a document rather than CMYK percentages. See also *CMYK_REF.PS file, named color, PANTONE Matching System*.

PANTONEU.PS. A PANTONE uncoded file that allows you to choose a named PANTONE color for a document rather than CMYK percentages. See also *CMYK_REF.PS file, named color, PANTONE Matching System*.

parallel-attached. See *parallel printer*.

parallel port. A port that supplies the synchronous, high-speed flow of data along parallel lines to peripheral devices, especially parallel printers. See also *parallel printer*.

parallel printer. A printer designed to be connected to a computer's parallel port. See also *parallel port*.

pel. See *pixel*.

photoconductor drum. A light-sensitive surface that when electrically charged can be discharged by the laser light beam. The remaining charged area

attracts applied toner particles from the toner cartridge and transfers the particles to the paper to produce a latent toned image. See also *electrostatic latent image*.

photoconductor drum cartridge. A customer-replaceable unit (CRU) that holds the photoconductor. See also *photoconductor drum*.

photoconductor drum cover. A cover that holds the used toner bottle in place on the photoconductor drum cartridge.

photoconductor drum shield. The orange cover installed on the photoconductor drum cartridge that protects the photoconductive surface from light when the cartridge is not installed in the printer. See also *photoconductor drum cartridge*.

photodiode. A photoelectric semiconductor device for detecting and measuring radiant energy such as light.

photographic style. A rendering style that preserves tonal relationships in images. Unprintable colors are mapped to printable colors in a way that keeps differences in lightness and slightly sacrifices color accuracy as necessary.

photosensitive drum. A deprecated term for *photoconductor drum*. See *photoconductor drum*.

PICT. A Macintosh graphics file format developed by Apple Computer. PICT files consist of separate graphics objects like lines, arcs, ovals, or rectangles that you can independently edit, size, move, or color.

pixel (pel). (1) The smallest distinct element of a raster image or an image displayed on a monitor. (2) The elementary graphical cell that constitutes an image. (3) An element of a raster pattern or a point where a toned area on a photoconductor can appear.

pixels per inch (ppi). The number of pixels per linear inch. Unlike dots, which are bilevel entities, pixels can hold multiple levels of information. See also *dots per inch*, *pixel*.

point. A unit of about 1/72 of an inch that is used to measure typefaces.

point size. See *point*.

port. An entry or exit boundary mechanism that controls and synchronizes the flow of data into and out of a processor from and to external devices such as printers and modems.

portrait orientation. Text and images that are printed parallel to the wider side of the paper. Contrast with *landscape orientation*.

PostScript. The page-description language developed by Adobe Systems that has become a standard for graphic design and layout software. PostScript files can hold both vector and raster data, and fonts are defined with PostScript coding. Many desktop publishing systems output PostScript data that is interpreted by a laser printer.

PostScript level 2. The current version of PostScript language that is used to print and display pictures and text. PostScript level 2 includes many enhancements to older versions of PostScript, including improved color matching and the ability to control printer-specific features from applications.

Power Saver. A mechanism on the printer that sets the amount of time the printer stays idle before changing to a lower power-consumption mode.

power-on self-test (POST). A series of electrical and mechanical tests made by the printer. If the tests reveal an electrical or mechanical problem, you see an error message on the display panel.

presentation style. A rendering style that does not match printed colors to displayed colors precisely. Presentation rendering is used for bright saturated colors in illustrations and graphs.

print job. See *job*.

print mode. The working mode in which the printer gets information from the controlling computer system and produces printouts. Contrast with *diagnostic mode* and *test mode*.

print quality. The quality of printouts in relation to existing standards and to printouts from earlier jobs.

Print queue. A storage area for the printer that supplies a job storage, queueing, and spooling. When you submit a job to the Print queue, the printer gets the job immediately and stores it on the printer's hard disk. Jobs in the Print queue print in the order the printer receives them. You can use the IBM Color Spooler to move jobs from the Print

queue to the Hold queue or to discard them. Finished jobs in the Print queue are automatically moved to the Printed queue if it is enabled. See also *IBM Color Spooler*.

Printed queue. A storage area for the printer that moves a finished job from the Print queue to the Printed queue for temporary storage. You can then use the IBM Color Spooler to move the job into the Print queue or the Hold queue, or to discard it from the printer's hard disk. See also *IBM Color Spooler*.

primary charging. The uniform charging of the photoconductor drum cartridge with negative potential.

process color. A mixture of CMYK inks that simulates a specified color. Process color is the traditional method for reproducing continuous-tone color images. See also *spot color*.

protocol adapter. A device for attaching a printer to a token-ring network through a parallel port. The AXIS Protocol Adapter: Token Ring, available from retail suppliers, is the recommended device. See also *token-ring network*.

Q

QuarkXPress. A page layout program developed by Quark, Inc., for Macintosh computers and PCs that accepts documents of unlimited length and includes many word processing functions.

Quickdraw. The graphics and display technology built into Macintosh computers. Quickdraw is the equivalent of the PostScript language to send words and pictures to printers.

R

raster. (1) On a computer monitor or television screen, the horizontal pattern of lines that forms the image. (2) A pattern of dots that consist of different data depths. For example, images with only black-and-white values are 1-bit (on or off), grayscale images are 8-bit (256 levels), RGB images are 24-bit (3 channels of 8 bits each), and CMYK images are 32-bit (4 channels.) Also called a *bitmap*.

raster image. A series of pixels arranged in scan lines to form an image.

raster image processor (RIP). A computer processor that renders PostScript instructions into dot patterns that are transferred to the final print medium. Most RIPs use reduced instruction set computer (RISC) processors to achieve extremely high throughput. A RIP typically includes a substantial amount of RAM to store the image as it is formed and a hard disk to buffer multiple pages. See also "*ripping*."

red, green, blue (RGB). The colors of computer monitor phosphors. RGB images are for monitor display only and are converted to CMYK images before printing.

registration. In printing, the relative print positions of images that are printed at different times. For example, when you print on preprinted forms, the registration is good if the new image is aligned correctly with the preprinted image. Print that extends beyond box edges and text that overlaps other text are examples of poor registration.

rendering style. A feature of the printer's color management software that enables the best possible translation of color from one color device to another. The color-rendering styles that you can choose using their respective color-rendering dictionary (CRD) name are monitor, photographic, presentation, and solid color. See also *rendering style, monitor style, photographic style, presentation style, solid-color style*.

relocation kit. The packaging and instructions you need to safely move the printer a substantial distance.

rendering. See *color-rendering style, photographic rendering*.

"ripping." Raster-image processing. See also *raster-image processor*.

route power cable. A cable that connects the power outlet on the optional tray 2 paper feeder with the power receptacle on the body of the printer.

S

scanner. A device that examines OCR, MICR, or bar code patterns, generates electrical signals corresponding to the patterns, and sends the signals to a computer for processing.

scatter. To cause a beam of radiation to diffuse or disperse.

security paper. Specially formulated paper used for negotiable documents like checks to prevent fraud.

separation. The process of separating a color image into cyan, magenta, yellow, and black, the primary color components for printing.

separation corona. The unit in the printer that electrically charges paper to attract photoconductor toner onto the paper. The separation corona has a thin, electrically charged wire inside a metal tube with a narrow opening.

separation corona mode. The voltage control mode for the separation corona. You can adjust the mode on the printer's density gauge to resolve print quality problems by choosing voltage control on, off, or on or off in response to the environment. See also *density control panel*, *density gauge*, *separation voltage*.

separation voltage. The ac corona charges applied in the separation charging unit to prevent image distortion in low-temperature, low-humidity environments. See also *separation corona*, *separation corona mode*.

server. See *file server*.

SETUP.EXE file. The file used to run a utility such as the IBM Color Downloader.

side-registration adjustment dial. A dial at the back of the printer that adjusts the side registration of the tray 2 paper feeder.

single inline memory module (SIMM). A plug-in memory module holding all the chips needed to add 256K or 1M of random access memory (RAM) to a computer.

shipping spacers. Any of several kinds of materials used to secure parts of the printer during shipping.

side output tray. When open, a tray that receives printouts faceup. The side output tray holds approximately 20 sheets of plain paper at 80 g/m².

simplex printing. Printing or reproducing in which only one side of the page is printed or reproduced.

small computer system interface (SCSI). A standard for attaching peripheral hardware to computers.

soft font. A printer font that must be transferred from a computer's or printer's hard disk to the printer's random access memory (RAM) before the printer can use the font. Also called *downloadable font*.

solenoid. An electrical conductor wound as a helix with a small pitch or as two or more coaxial helices.

solid-color style. A rendering style that maps unprintable colors to the closest printable colors when color accuracy is crucial. See also *color-rendering style*, *photographic rendering*, and *presentation rendering*.

Spooler utility. See *IBM Color Spooler*.

spooling. The use of auxiliary storage as buffer storage to reduce processing delays when transferring data between peripheral equipment and the processors of a computer.

spot color. Individual colored inks formulated to match a specified color exactly. See also *process color*.

star network. A local area network (LAN) with a centralized topology and the physical layout of a star. See also *Ethernet*, *token-ring network*.

status message. An operator message that you see on the display panel reporting on the current state of the printer.

subnet mask. A filter for Internet protocol (IP) addresses that allows those addresses local to the network to be visible to the printer.

supplies replacement log. A form provided in the *Operator's Guide* on which you note printer supplies you replace and the date and print count at the time you replace them.

SyQuest. A hard disk with removable media that is useful for the rapid transfer of large files between systems.

T

tagged image file format (TIFF). A bitmapped graphics format for scanned images of up to 300 dpi.

TCP/IP transmission control protocol/Internet protocol. The standard used by the Internet for transmitting information.

telnet. In TCP/IP, an application protocol that allows a user at one site to access a remote system as if the user's computer were locally attached. Telnet uses TCP as the underlying protocol. See also *TCP/IP*.

test mode. The operational mode in which the printer can produce print samples, accept configuration changes, and control traces.

test page. A page you can print to see samples of color and grayscale on the printer.

text orientation. The position of text as a combination of print direction and baseline direction. See also *orientation*.

thermistor. A semiconductor device whose electric resistance is dependent on temperature.

token. In a local area network (LAN), a message or bit pattern that signifies permission to transmit. The token is passed successively from one workstation to another to indicate the workstation temporarily in control of the transmission medium. See also *token-ring network*.

token-ring network. A local area network (LAN) with an architecture that combines token-passing with a hybrid star-and-ring topology. See also *Ethernet*, *star network*, *token*.

toner. In color printing, the material that forms an image on paper. Toner adheres to the exposed areas on the photoconductor drum during the developing process and is then transferred to the paper to form the developed image on the paper.

toner cartridge. A cylindrical unit that supplies the toner for one of the four colors (cyan, magenta, yellow, and black) used for color printing. Four toner cartridges fit in the printer's turret. See also *turret*.

toner cartridge position mark. A mark on the printer's turret that you use to align with the arrow on a toner cartridge.

toner projection development. The process in which, when the area on the printer's photoconductor drum cartridge that is irradiated by the laser beam comes close to the negatively charged toner on the cylinder, the difference in potential causes the toner to jump across and adhere to the drum surface.

topology. The geometric arrangement of nodes and cable links in a local area network (LAN).

top output tray. When the side output tray is closed, a tray that receives printouts facedown. The top output tray holds approximately 20 sheets of plain paper at 80 g/m².

torque. A force that produces rotation or torsion.

trailing edge. The edge of the paper that goes into the printer last as it is inserted by the paper feeder.

transceiver chip. Semiconductor material used for transmitting and receiving signals.

transfer drum. The part of the printer where a toned image on the photoconductor drum is transferred to the paper.

transfer sheet. A special plastic-like material that surrounds the transfer drum and can maintain an electrical charge for paper attraction and image transfer. See also *transfer drum*.

transmission control protocol/Internet protocol (TCP/IP). The standard used by the Internet for transmitting information.

transparency. An acetate sheet that holds information to be shown by an overhead projector.

transparency film. See *transparency*.

tray. A receptacle to store paper or transparencies for printing. The printer has three trays: tray 1 used for paper, tray 2 used for paper, and an auxiliary tray used for paper and transparencies.

TrueType. A font technology that offers scalable fonts to Macintosh and Windows systems for display on monitors and for use on printers.

turret. A rotating device in the printer that positions a selected toner cartridge for transferring toner to the photoconductor drum.

turret rotation knob. The knob on the printer's turret that you push and turn to replace a toner cartridge.

U

universal paper cassette. A receptacle that fits into the printer's tray 1 paper feeder or optional tray 2 paper feeder. The universal paper cassette accepts Letter, Legal, A4, and JIS B5 paper sizes, and holds about 250 sheets (at 80 g/m²) of plain paper.

used-toner bottle. A bottle on the inside of the printer's front door that receives excess toner not fused during the print cycle.

V

vector. Absolute coordinate points and lines in space. PostScript files can hold vector graphics (also called *object-oriented artwork*). Vector files are converted to rasters in a raster image processor (RIP) during printing, giving the vector graphics device independence.

vector image. Graphics created on computers in which the pixels are defined mathematically as lines or curves between points. Graphics created in illustration and page layout applications are also vector images.

W

warning message. An operator message that causes the **Attention** light to flash to alert you to an upcoming problem. You press ENTER to see the message on the display panel. See also *error message*, *status message*.

wire cleaner. A small metal tool stored inside the printer and used to clean the separation corona wire and the window of the density detection sensor.

workstation. In a local area network (LAN), a desktop computer that runs application programs

and serves as an access point to shared network resources.

Z

zone. In a local area network (LAN), a subgroup of networked workstations set aside and named by the network administrator to be treated as a group.

Index

Symbols

- + symbol on display panel 4-4
- /+ push button 1-12, 6-22, 6-26
- ←→ push buttons 4-4
- ↑↓ push buttons 4-4

Numerics

- 60 000 usage kit
 - installing
 - air filter 8-6
 - fuser 5-19
 - ozone filter 8-6
 - separation corona unit 8-10
 - transfer drum cleaning assembly 8-12
 - ordering 1-5

A

- A4-size paper
 - border width 2-4
 - choosing from the Printer Setup menu 4-15
 - error message 7-14, 7-15
 - loading
 - auxiliary tray 3-6
 - tray 1 or tray 2 3-2
- A4-size transparencies
 - border width 2-4
 - error message 7-16
 - loading in auxiliary tray 3-6
- abbreviations X-1
- ACA POST error messages 7-3
- acceptable paper 2-2
- access door
 - feeder (tray 1) 1-7
 - feeder (tray 2) 1-7
 - fuser 1-7
- acronyms X-1
- adding paper. *See* loading paper
- adhesive paper 2-3
- adjustment dial, left-side registration 1-9
- aerosol spray, effects on toner cartridges 5-2
- air filter

- holder 1-9, 8-6
 - replacing 8-6 to 8-7
- air ventilation slots 1-9
- arrow push buttons 4-4
- Attention light
 - flashing 7-5, 7-8
 - location 4-2
- attention safety notice xii
- audience of manual xi
- Auto Select, selecting from Printer Setup menu 4-15
- auxiliary tray
 - capacity
 - paper 3-6
 - transparencies 3-9
 - closing 3-12
 - loading
 - paper 3-6 to 3-8
 - transparencies 3-9
 - location 1-7
 - opening 3-6
 - paper guides 3-7, 3-8
 - paper-limit mark 3-8
 - selecting from Printer Setup menu 4-15

B

- B5-size paper
 - border width 2-4
 - choosing from the Printer Setup menu 4-15
 - error message 7-15, 7-16
 - loading
 - auxiliary tray 3-6
 - tray 1 or tray 2 3-2
- bag, toner cartridge 5-7, 5-9
- belt, cleaning 7-6, 7-13
- black lines on printout 6-16
- black printout problem 6-15
- black spots on printout 6-18
- black toner cartridge
 - error message 7-6, 7-13
 - ordering 1-4
 - See also* toner cartridge
- blank printout problem 6-14
- blue bar on the paper amount indicator 3-2
- borders, width measurements 2-4

- bottle
 - cover, fuser oil 1–10
 - fuser oil 1–6
 - oil recycle 5–19
 - used toner 1–10
- brush, density detection sensor cleaning 8–4
- Busy light 4–2
- button, release 3–3
 - See also* push button

C

- cable, route power
 - tray 1 1–7
 - tray 2 1–9
- Cancel push button 4–3
- cancelling a print job 4–5
- capacity
 - auxiliary tray
 - paper 3–6
 - transparencies 3–9
 - side output tray 3–13
 - top output tray 3–15
 - tray 1 or tray 2 3–2
- carbon paper 2–3
- cartridge, toner. *See* toner cartridge
- cassette, paper
 - feature 1–3
 - tray 1 1–7
 - tray 2 1–7
 - See also* tray 1, tray 2
- casters, printer stand 5–20
- caution safety notice xii
- changing a password 4–21
- choosing
 - output delivery 3–13 to 3–15
 - paper 2–2 to 2–3
- Clean Earth Campaign 5–13, 5–38
- cleaning
 - density detection sensor window 8–4 to 8–5
 - fusing rollers 8–5
 - paper feeder area 8–3
 - separation corona wire 5–39 to 5–40
 - transfer drum 8–3
- cleaning belt, error message 7–6, 7–13
- cleaning connector cover
 - removing 8–13
 - replacing 8–17
- Clear Log/Queues Setup menu 4–11
- CMYK, color lights 1–12
- coated paper 2–2
- collated documents 3–15
- color density, adjusting 6–22 to 6–23
- color distortion on printout 6–19
- color light on the density control panel 1–12
- color markers, toner cartridge 5–6, 5–8

- color mode, setting from Printer Setup menu 4–16
- color pages, printing 4–10
- color problem on printout 6–19
- COLOR SELECT push button 1–12
- configuration page, printing 4–9
- consumables. *See* supplies
- control panel
 - density. *See* density control panel
 - operator. *See* operator panel
- control push button
 - Cursor Position 4–4
 - Enter 4–4
 - Menu 4–3
 - Menu Scrolling 4–4
- corona. *See* separation corona unit
- corrosive gases, effects on toner cartridges 5–2
- cover
 - cleaning connector 8–13
 - developing cylinder 5–10
 - fuser oil bottle 1–10
 - paper guide 6–7, 6–8
 - photoconductor drum 5–14
 - top 1–6
- cover page, setting from Printer Setup menu 4–16
- curling
 - paper 2–5, 3–8
 - transparencies 3–13
- Cursor Position push buttons 4–4
- cyan toner cartridge
 - error message 7–6, 7–13
 - ordering 1–4
 - See also* toner cartridge

D

- danger safety notice xii
- dark image on printout 6–14
- date, changing in System Setup menu 4–20
- DC controller error message 7–12 to 7–13
- default settings, defining for the printer 4–11
- deleting a password 4–13
- density control panel
 - adjusting color density 6–22
 - location 1–9
 - parts 1–12
 - printing a test print 6–24 to 6–25
- density detection
 - error 7–6, 8–4
 - sensor
 - cleaning 8–4 to 8–5
 - error message 7–6, 7–12
 - location 6–4, 8–4
- density gauge 1–12, 6–26
- description of printer 1–2
- developing cylinder cover 5–10
- diagram, wiring Appendix C–1

- dial, left-side registration adjustment 1–9
- dirty printout 6–15, 6–16
- display panel
 - choosing a menu setting 4–7
 - location 4–3
 - navigating the menus 4–7
- disposal of materials xiii
 - See also* recycling
- distorted image on printout 6–18
- door
 - close door error message 7–10
 - closing problem 6–2
 - feeder access (tray 1) 1–7
 - feeder access (tray 2) 1–7
 - front 1–7
 - fuser access 1–7
 - handle, photoconductor drum cartridge 1–11
- DRAM POST error messages 7–3
- drum knob, transfer 1–10
- drying printouts 2–5

E

- effective printing area 2–4
- eject handle
 - location 1–10
 - using during toner cartridge replacement 5–4
- electrical safety xii
- Energy Star low power consumption 4–23
- English paper sizes 4–15
- ENTER push button (density control panel) 1–12
- Enter push button (operator panel) 4–4
- envelopes, printing 2–2
- EPROM POST error messages 7–2
- Error Log, printing 4–8
- error messages
 - operator error 7–8 to 7–17
 - power-on self-test (POST) 7–2 to 7–4
 - See also* messages
- ETH POST error messages 7–3
- Exit Setup menu 4–11
- extension tray 3–6

F

- facedown
 - delivery, selecting 3–15
 - output tray. *See* top output tray
- faceup
 - delivery, selecting 3–13
 - output tray. *See* side output tray 1–7
- fading printouts 2–5
- fan error messages 7–11 to 7–12
- fanning paper 3–4
- features of printer 1–3

- feeder access door
 - opening 5–24
 - tray 1 1–7, 6–9
 - tray 2 1–7
- feeder, paper. *See* paper feeder
- film. *See* transparencies
- filter
 - air, replacing 8–6 to 8–7
 - holder, air 1–9
 - ozone, replacing 8–6 to 8–9
- fingerprints on transparencies 2–6
- fixer. *See* fuser
- font page, printing 4–8, 4–10
- front door
 - laser interlock 6–14
 - location 1–7
- fuser
 - cleaning belt 7–6, 7–13
 - error messages 7–8 to 7–10, 7–14
 - failure 7–9
 - handholds 5–26
 - jam release lever 5–23
 - paper jam error message 7–16
 - pump, error message 7–13
 - replacing 5–19 to 5–32
 - filling the new fuser unit with fuser oil 5–30
 - installing the new fuser 5–27
 - locating tools 5–19
 - preparing the work area 5–20
 - removing the fuser access door 5–24
 - removing the fuser oil from the printer 5–21
 - removing the used fuser 5–26
 - replacing the fuser access door 5–29
 - unpacking the new fuser 5–20
 - screws 5–26, 5–27
 - shipping spacers 5–28
- fuser access door
 - location 1–7
 - opening 5–21
 - removing 5–24
 - replacing 5–29
 - strap, releasing 5–24
- fuser oil
 - add fuser oil error message 7–10
 - adding 5–16 to 5–18
 - low fuser oil error message 7–6
 - on a transparency 2–6
 - ordering 1–4
 - pump, error message 7–13
 - removing from printer 5–21 to 5–23
- fuser oil bottle
 - cover 1–10
 - location 1–6
 - replacing 5–16 to 5–18
 - installing a new fuser oil bottle 5–17
 - removing the old fuser oil bottle 5–16
- fuser rollers

- binding 7–11
- cleaning 8–5
- paper jam 6–8
- print quality problems 6–15 to ??
- unlocking 6–8
- fuser test page, printing 4–8
- fusing problems on printout 6–18

G

- gauge, density 1–12
- glossary X–3
- gluing printouts together 2–5
- guide
 - in auxiliary tray 3–7, 3–8
 - paper length 3–3
 - paper width 3–3
- guide pins, on transfer drum cleaning assembly 8–15

H

- handhold, fuser 5–26
- handle
 - eject 1–10
 - photoconductor drum cartridge door 1–11
 - release 1–10
- handling
 - paper 2–5
 - printouts 2–5
 - transparencies 2–6
- heavy-weight paper
 - delivering to side output tray 3–13
- Help Map
 - printing 4–9
 - sample Appendix A–6
- highlights of printer 1–2
- holder, air filter 1–9, 8–6
- humidity effects
 - paper 2–5
 - toner cartridges 5–2
 - transparencies 2–6

I

- image quality. *See* print quality problem
- inappropriate paper
 - paper that could damage the printer 2–3
 - paper that easily causes paper jams 2–2
 - paper that is affected by high temperature 2–3
- indicator
 - paper amount 1–7
 - paper size 1–7, 3–4
- ink. *See* toner
- introduction 1–2

J

- jam, paper
 - fuser area 6–6
 - locations 6–3
 - paper feeder area (tray 1) 6–9
 - paper feeder area (tray 2) 6–12
 - recurring 6–2
 - transfer drum area 6–4
- JIS B5-size paper. *See* B5-size paper
- Job Log Setup menu 4–11
- Job Log, printing 4–9

K

- knob
 - fuser pull 5–26, 5–27
 - transfer drum 1–10
 - turret rotation 1–11, 5–5, 5–8, 5–9

L

- label, serial number 1–11
- labels, printing 2–2
- Language menu 4–24
- large print jobs
 - handling 3–15
 - setting Print to PS Error 4–17
- laser error messages 7–10
- laser interlock, front door 6–14
- laser safety xiii
- latch, release 1–7
- left-side registration
 - adjusting 6–20 to 6–21
 - adjustment dial 1–9
- legal-size paper
 - border width 2–4
 - choosing from the Printer Setup menu 4–15
 - error message 7–14, 7–15
 - loading
 - auxiliary tray 3–6
 - tray 1 or tray 2 3–2
- letter-size paper
 - border width 2–4
 - choosing from the Printer Setup menu 4–15
 - error message 7–14, 7–15
 - loading
 - auxiliary tray 3–6
 - tray 1 or tray 2 3–2
- letter-size transparencies
 - border width 2–4
 - error message 7–16
 - loading in auxiliary tray 3–6
- lever, fuser jam-release 5–23
- light

- Attention 4–2
- Busy 4–2
- color 1–12
- Online 4–3
- operator panel 4–2
- Power 4–2
- light image on printout 6–14
- lines on printout 6–16, 6–17
- load paper error messages 7–14 to 7–16
- loading
 - paper
 - auxiliary tray 3–6 to 3–8
 - tray 1 or tray 2 3–2 to 3–6
 - transparencies 3–9 to 3–11
- log, supplies replacement Appendix B–1
- low fuser oil error message 7–6
- low toner error message 7–6

M

- magenta toner cartridge
 - error message 7–6, 7–14
 - ordering 1–4
 - See also* toner cartridge
- maintenance
 - cleaning the paper path 8–3 to 8–5
 - replacing the air and ozone filters 8–6 to 8–9
 - replacing the separation corona unit
 - 8–10 to 8–11
 - replacing the transfer drum cleaning assembly
 - 8–12 to 8–17
- manual
 - intended audience xi
 - organization xi
 - related publications xiii
 - terminology in xii
- manual paper feed. *See* auxiliary tray
- mark
 - paper limit
 - auxiliary tray 3–8
 - tray 1 and tray 2 3–5
 - position for toner cartridge 1–10
- marks on paper. *See* print quality problem
- material disposal xiii
 - See also* recycling
- measurement, border width 2–4
- memory upgrades 1–3
- Menu push button 4–3
- Menu Scrolling push buttons 4–4
- menus
 - choosing a setting 4–7
 - display panel 4–6
 - Language 4–24
 - navigating 4–7
 - operator panel 4–6
 - Print Pages

- color pages 4–10
- configuration page 4–9
- font page 4–10
- Help Map 4–9
- job log 4–9
- test page 4–10
- Printer Setup
 - Color Mode 4–16
 - Paper Size 4–15
 - Paper Source 4–14
 - Print Cover Page 4–16
 - Print Start Page 4–18
 - Print to PS Error 4–17
- System Setup
 - Change Password 4–21
 - Power Svngs 4–23
 - Printer Name 4–20
 - System Date 4–20
 - System Time 4–20

- messages
 - display priority 7–5
 - error 7–8 to 7–17
 - power-on self-test (POST) 7–2 to 7–4
 - status 7–7
 - warning 7–5 to 7–6
- metric paper sizes 4–15
- MIPS POST error messages 7–2
- moisture, effects on toner cartridges 5–2
- motor error messages 7–10 to 7–11
- multipurpose tray. *See* auxiliary tray

N

- name of printer, changing 4–20
- navigating display panel menus 4–7
- Network Setup menu 4–11
- notices
 - safety xii
 - trademark vii

O

- offline menus
 - accessing 4–12
 - available menus 4–11
 - Language 4–24
 - Printer Setup
 - Color Mode 4–16
 - Paper Size 4–15
 - Paper Source 4–14
 - Print Cover Page 4–16
 - Print Start Page 4–18
 - Print to PS Error 4–17
 - System Setup
 - Change Password 4–21

- Power Svngs 4–23
- Printer Name 4–20
- System Date 4–20
- System Time 4–20
- offline status 4–2
- OFFLINE status message 7–7
- oil bottle
 - cover 1–10, 5–30
 - fuser 1–6
 - holder 5–17, 5–30
- oil recycle bottle
 - locating 5–19
 - opening 5–22
- oil removal tool 5–19
- Online light 4–3
- online menus
 - accessing 4–8
 - printing a configuration page 4–9
 - printing a job log 4–9
 - printing a test page 4–10
 - printing the color pages 4–10
 - printing the Help Map 4–9
- Online push button 4–2
- online status 4–2
- operator message
 - display priority 7–5
 - error 7–8 to 7–17
 - status 7–7
 - warning 7–5 to 7–6
- operator panel
 - Cancel push button 4–3
 - canceling a print job 4–5
 - control push buttons 4–3
 - display panel 4–3
 - display panel menus 4–6 to 4–7
 - entering a password 4–13
 - identifying the parts 4–2 to 4–4
 - Language menu 4–24
 - lights 4–2
 - offline menus 4–11 to 4–12
 - Online light/push button 4–2
 - online menus 4–8 to 4–10
 - Print Pages menu 4–8 to 4–10
 - Printer Setup menu 4–14 to 4–18
 - System Setup menu 4–19 to 4–23
- optional features of printer 1–3
- optional paper feeder. *See* paper feeder
- orange photoconductor drum shield 5–34, 5–35, 5–36
- ordering supplies, phone number 1–4, 5–3
- organization of manual xi
- output tray
 - choosing 3–13 to 3–15
 - for collated documents 3–15
 - for heavy-weight paper 3–13
 - for large print jobs 3–15
 - problem choosing 6–2
 - side output

- capacity 3–13
- choosing 3–13
- closing 3–14
- location 1–7
- opening 3–13 to 3–14
- top output
 - capacity 3–15
 - choosing 3–15
 - large print jobs 3–15
 - location 1–8
- ozone filter, replacing 8–6 to 8–9

P

- panel
 - density control. *See* density control panel
 - display 4–3
 - operator. *See* operator panel
- paper
 - acceptable 2–2
 - adding. *See* paper, loading
 - adhesive 2–3
 - amount indicator 1–7
 - carbon 2–3
 - choosing 2–2 to 2–3
 - coated 2–2
 - curling 2–5, 3–8
 - effects of humidity 2–5
 - effects of sunlight 2–5
 - fanning 3–4
 - handling and storing 2–5 to 2–6
 - heavy-weight paper 3–13
 - inappropriate 2–2
 - jams 6–3 to 6–12
 - loading
 - auxiliary tray 3–6 to 3–8
 - tray 1 or tray 2 3–2 to 3–6
 - moving to a new location 2–5
 - predrilled, problems with 2–2, 6–15
 - preprinted 2–3
 - printing area on a page 2–4
 - sizes
 - auxiliary tray 3–6
 - tray 1 or tray 2 3–2
 - specifications 2–2
 - storing 2–5
 - textured 2–2
 - thermal 2–3
 - width of borders 2–4
- paper amount indicator 3–2
- paper cassette, universal
 - features 1–3
 - location as tray 1 1–7
 - location as tray 2 1–7
 - See also* tray 1, tray 2
- paper delivery

- print quality problem
 - all black (any color) prints 6–15
 - black spots 6–18
 - blank prints 6–14
 - color distortion 6–19
 - color fading or missing 6–19
 - dark image 6–14
 - dirt on back of paper 6–15
 - dirty prints or background 6–16
 - distortion 6–18
 - light image 6–14
 - poor print quality 6–2
 - toner rubs off 6–18
 - toner streaking or scatter 6–19
 - vertical lines on print 6–16
 - white horizontal lines on print 6–17
 - white vertical lines on print 6–17
 - Print Start Page, setting from Printer Setup menu 4–18
 - Print to PS Error, setting from Printer Setup menu 4–17
 - printable area 2–4
 - printer
 - canceling a job 4–3, 4–5
 - default settings 4–11
 - general description 1–2
 - highlights 1–2
 - maintenance. *See* maintenance
 - name, changing from System Setup menu 4–20
 - offline 4–2
 - online 4–2
 - optional features 1–3
 - parts and controls
 - back side 1–9
 - density control panel parts 1–12
 - front side 1–6
 - inside front door 1–10
 - left side 1–9
 - operator panel 4–2 to 4–4
 - right side 1–6
 - problems. *See* problems
 - resetting 1–14
 - resolution 1–2
 - speed 1–2
 - spooling 4–2
 - stand
 - casters 5–20
 - location 1–3
 - status 7–7
 - turning on and off 1–13 to 1–14
 - Printer Setup menu
 - accessing 4–14
 - available options 4–14
 - choosing the color mode 4–16
 - choosing the paper size 4–15
 - choosing the paper source 4–14
 - choosing to print a cover page 4–16
 - choosing to print a start page 4–18
 - choosing to print when there is a PS error 4–17
 - function 4–11
 - printing
 - area on a page 2–4
 - envelopes 2–2
 - labels 2–2
 - status 7–7
 - PRINTING status message 7–7
 - printouts
 - delivery problem 6–2
 - drying 2–5
 - effects of temperature 2–5
 - fading 2–5
 - gluing together 2–5
 - handling 2–5
 - storing 2–5
 - storing with polyvinyl chloride (PVC) 2–5
 - problems
 - adjusting the left-side registration on tray 2 printouts 6–20 to 6–21
 - color density 6–22 to 6–25
 - common problems 6–2
 - paper jams 6–3 to 6–12
 - print quality problems 6–13 to 6–19
 - printout delivery 6–2
 - setting the separation corona mode 6–26
 - PROCESSING status message 7–7
 - publications, related xiii
 - pull knobs, fuser 5–26, 5–27
 - pump, fuser 7–13
 - push button
 - /+ 1–12, 6–22, 6–26
 - Cancel 4–3
 - COLOR SELECT 1–12
 - Cursor Position 4–4
 - Enter 4–4
 - ENTER (density control panel) 1–12
 - Menu 4–3
 - Menu Scrolling 4–4
 - Online 4–2
 - TEST PRINT 1–12
- ## Q
- quality problem. *See* print quality problem
 - Queue Setup menu 4–11
- ## R
- READY status message 7–7
 - receptacle, power 1–7
 - recycling
 - photoconductor drum cartridge 5–38
 - toner cartridge 5–13

- registration adjustment dial 1–9
 - registration, setting width 6–20 to 6–21
 - related publications xiii
 - release
 - button, paper-width guide 3–3
 - handle 1–10
 - latches 1–7
 - lever, fuser jam 5–23
 - replacing
 - air filter 8–6 to 8–7
 - fuser 5–19 to 5–32
 - fuser oil bottle 5–16 to 5–18
 - ozone filter 8–6 to 8–9
 - photoconductor drum cartridge 5–33 to 5–40
 - separation corona unit 8–10 to 8–11
 - toner cartridges 5–4 to 5–13
 - transfer drum cleaning assembly 8–12 to 8–17
 - used toner bottle 5–14 to 5–15
 - requesting service xiii
 - resetting the printer 1–14
 - resolution of printer 1–2
 - rollers, fuser 6–8, 6–15 to ??, 8–5
 - rotation knob, turret 1–11
 - route power cable
 - tray 1 1–7
 - tray 2 1–9
 - RTC POST error messages 7–2
 - Run Setup menu
 - Clear Log/Queues Setup 4–11
 - entering a password 4–13
 - Exit Setup 4–11
 - Job Log Setup 4–11
 - Network Setup 4–11
 - Printer Setup 4–11
 - Queue Setup 4–11
 - System Setup 4–11
- ## S
- safety
 - disposal of materials xiii
 - electrical xii
 - laser xiii
 - notices xii
 - precautions xii
 - screw, fuser 5–26, 5–27
 - screwdriver 5–19
 - SCSI POST error messages 7–4
 - sealing tape, toner cartridge 5–10
 - separation corona unit
 - cleaning the wire 5–39 to 5–40
 - installing a new one 8–11
 - location 1–8
 - removing the old one 8–10
 - replacing 8–10 to 8–11
 - setting the mode 6–26
 - wire cleaner 1–8
 - separation voltage control designation mode 6–26
 - serial number label 1–11
 - service, requesting xiii
 - setting a password 4–21
 - Setup menu
 - Clear Log/Queues Setup 4–11
 - Exit Setup 4–11
 - Job Log Setup 4–11
 - Network Setup 4–11
 - Printer Setup 4–11
 - Queue Setup 4–11
 - System Setup 4–11
 - shield, photoconductor drum cartridge 5–36
 - side output tray
 - capacity 3–13
 - choosing 3–13
 - closing 3–14
 - location 1–7
 - opening 3–13 to 3–14
 - silicone oil. *See* fuser oil
 - size, paper. *See* paper size
 - solvents affecting toner 2–5
 - spacers, fuser shipping 5–28
 - specifications, paper 2–2
 - speed of printer 1–2
 - spooling 4–2
 - spots on printout 6–18
 - stand, printer 1–3
 - start page, setting from Printer Setup menu 4–18
 - status messages 7–7
 - storing
 - paper 2–5
 - printouts 2–5
 - strap, fuser access door 5–24
 - sunlight effects
 - paper 2–5
 - photoconductor drum cartridge 5–35
 - toner cartridges 5–2
 - supplies
 - list 1–4 to 1–5
 - phone number for ordering 1–4, 5–3
 - replacement log Appendix B–1
 - replacing
 - air and ozone filters 8–6 to 8–9
 - fuser 5–19 to 5–32
 - fuser oil bottle 5–16 to 5–18
 - photoconductor drum cartridge 5–33 to 5–40
 - separation corona unit 8–10 to 8–11
 - toner cartridges 5–4 to 5–13
 - transfer drum cleaning assembly 8–12 to 8–17
 - used toner bottle 5–14 to 5–15
 - storing and handling toner cartridges 5–2
 - support, requesting xiii
 - switch, power 1–7, 1–13
 - System Setup menu

- accessing 4–19
- available options 4–19
- changing the date 4–20
- changing the printer name 4–20
- changing the time 4–20
- function 4–11
- setting or changing a password 4–21
- setting or changing the Power Savings mode 4–23
- system time and date, changing 4–20

T

- telephone number
 - for obtaining IBM service xiii
 - for ordering supplies 1–4, 5–3
- temperature effects
 - printouts 2–5
 - toner cartridges 5–2
 - transparencies 2–6
- terminology used in manual xii
- test page, printing 4–10
- TEST PRINT push button 1–12
- test print, printing from density control panel 6–24 to 6–25
- textured paper 2–2
- thermal paper 2–3
- time, changing in System Setup menu 4–20
- toner
 - adding 5–4 to 5–13
 - dissolved by solvents 2–5
 - floating in air 8–2
 - low toner error message 7–6
 - rubbing off 6–18
 - streaking on printout 6–19
 - See also* toner cartridge
- toner bottle
 - error message 7–17
 - location 1–10
 - replacing 5–14 to 5–15
- toner cartridge
 - alignment in turret 5–8
 - arrangement of cartridges in turret 5–8
 - color markers 5–4, 5–8
 - disposal 5–2
 - error message 7–12, 7–13 to 7–14
 - location 1–10
 - ordering 1–4
 - position mark 1–10
 - protective bag 5–7, 5–9
 - recycling 5–13
 - replacing 5–4 to 5–13
 - installing a new cartridge 5–8
 - loading order 5–8
 - recycling the used toner cartridge 5–13
 - removing the old cartridge 5–5

- rotary error message 7–12
- sealing tape 5–10
- sensing windows 5–4, 5–9
- storing and handling 5–2
- tools, for replacing fuser 5–19
- top cover 1–6
- top output tray
 - capacity 3–15
 - choosing 3–15
 - collated documents 3–15
 - large print jobs 3–15
 - location 1–8
 - problem choosing 6–2
- towels 5–19
- trademarks vii
- transfer drum
 - cleaning 8–3
 - knob 1–10
 - paper jam error message 7–16
 - release handle 1–10
- transfer drum cleaning assembly
 - guide pins 8–15
 - replacing 8–12 to 8–17
 - installing new assembly 8–15
 - pulling out paper feeder 8–12
 - pushing in paper feeder 8–17
 - removing cleaning connector cover 8–13
 - removing used assembly 8–14
 - replacing cleaning connector cover 8–17
- transparencies
 - handling 2–6
 - loading 3–9 to 3–11
 - ordering 1–5
 - positioning markers 3–9
 - using only with IBM printers 2–6
- tray
 - auxiliary 1–7
 - capacity 3–2
 - choosing for input 4–14
 - choosing for output delivery 3–13 to 3–15
 - loading paper 3–2 to 3–6
 - side output
 - choosing 3–13
 - closing 3–14
 - location 1–7
 - opening 3–13 to 3–14
 - top output
 - capacity 3–15
 - choosing 3–15
 - for collated documents 3–15
 - for large print jobs 3–15
 - location 1–8
- tray 1
 - paper jam in 6–9
 - selecting from Printer Setup menu 4–15
 - universal paper cassette 1–7
- tray 2

- feeder access door 1–7
- left-side registration adjustment 6–20 to 6–21
- paper feeder 1–3, 1–7
- paper jam in 6–12
- selecting from Printer Setup menu 4–15
- universal paper cassette 1–7
- troubleshooting. *See* problems
- turning the printer on and off 1–13 to 1–14
- turret
 - rotation knob 1–11, 5–5, 5–8, 5–9
 - toner cartridges in 1–10

U

- universal paper cassette 1–3
- upgrades, memory 1–3
- usage kit
 - installing
 - air filter 8–6
 - fuser 5–19
 - ozone filter 8–6
 - separation corona unit 8–10
 - transfer drum cleaning assembly 8–12
 - ordering 1–5
- used toner bottle
 - attaching a new bottle 5–37
 - error message 7–17
 - installing 5–15
 - location 1–10
 - removing 5–15
 - sealing 5–15, 5–34
- user support, requesting xiii

V

- vacuum cleaner, using to clean paper feeder 8–3
- ventilation slots, air 1–9
- vertical lines on printout
 - black 6–16
 - white 6–17

W

- WARMING UP status message 7–7
- warning messages 7–5 to 7–6
- waste toner bottle. *See* used toner bottle
- white lines on printout
 - horizontal 6–17
 - vertical 6–17
- wire, separation corona 1–8, 5–39
- wiring diagram Appendix C–1

Y

- yellow toner cartridge
 - error message 7–6, 7–14
 - ordering 1–4
 - See also* toner cartridge

Free Manuals Download Website

<http://myh66.com>

<http://usermanuals.us>

<http://www.somanuals.com>

<http://www.4manuals.cc>

<http://www.manual-lib.com>

<http://www.404manual.com>

<http://www.luxmanual.com>

<http://aubethermostatmanual.com>

Golf course search by state

<http://golfingnear.com>

Email search by domain

<http://emailbydomain.com>

Auto manuals search

<http://auto.somanuals.com>

TV manuals search

<http://tv.somanuals.com>