

# **HERO**

*Industries*

## **INDUSTRIAL SERIES**

### **HRO-ST3131**

# **OWNERS MANUAL**

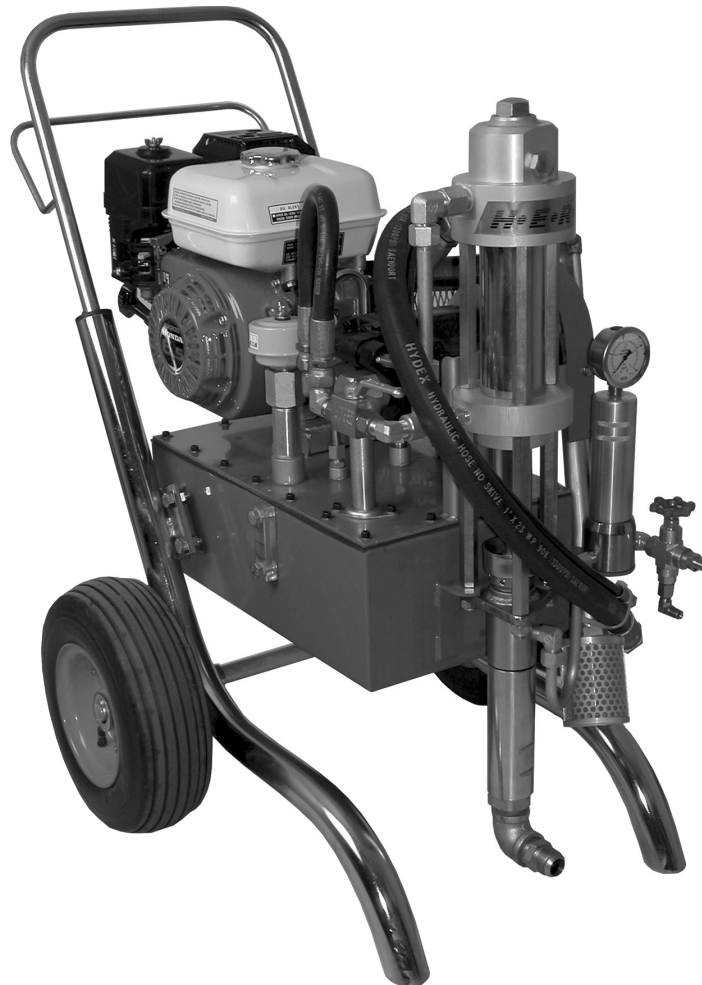

#### **WARNING**

**DO NOT ATTEMPT TO OPERATE THIS MACHINE UNTIL YOU HAVE READ AND UNDERSTOOD ALL SAFETY PRECAUTIONS AND OPERATING INSTRUCTIONS. EQUIPMENT AND CHEMICALS WHEN USED IMPROPERLY CAN BE DANGEROUS.**

## ***H.E.R.O. WARRANTY***

H.E.R.O. INDUSTRIES , guarantees this airless pump to be free of defects in materials and workmanship to the original owner, for a period of one full year from the date of purchase.

The warranty entitles the owner to parts replacement at no charge. The parts replacement warranty is valid for any necessary replacement, whither caused by material or workmanship defect or simple wear. H.E.R.O. Industries offers no warranty on the intake ball, outgo ball, drive belt, hoses, gun or accessories, plastic, rubber, other soft goods or motor used in or supplied with the H.E.R.O. sprayer.

Motor, accessories, etc., which are supplied by other manufacturers and are attached to or supplied with the H.E.R.O. airless pump, are warranted only to the extent that these parts are warranted by their respective manufacturers. Warranty claims must be made directly to such manufacturers or their local authorized service depots.

The warranty is only applicable to the original purchaser and the equipment has been properly used, operated and maintained in accordance with all instructions, precautions and warnings contained in this manual. For the purpose of this warranty, damage resulting from accident, abuse, improper cleaning or operation, fire, flood, or Act of God, is not covered.

H.E.R.O.'s liability is limited to replacing parts found to be defective or worn and does not include; transportation costs, damage or other expenses of any kind incurred in connection with the purchase and use of this sprayer.

Repairs claimed under warranty must be performed at an authorized H. E.R.O. Service Center, using only genuine H.E.R.O. parts. Parts necessary under warranty claim will be supplied by your local H.E.R.O. Service Center.

**DO NOT** return worn parts to factory without authorization.

To qualify for the warranty, the warranty card (attached to this page) supplied with this H.E.R.O. airless pump, must be completed with equipment serial number and signed by the purchaser, and postmarked within ten (10) days of purchase.

# UNIT LAYOUT

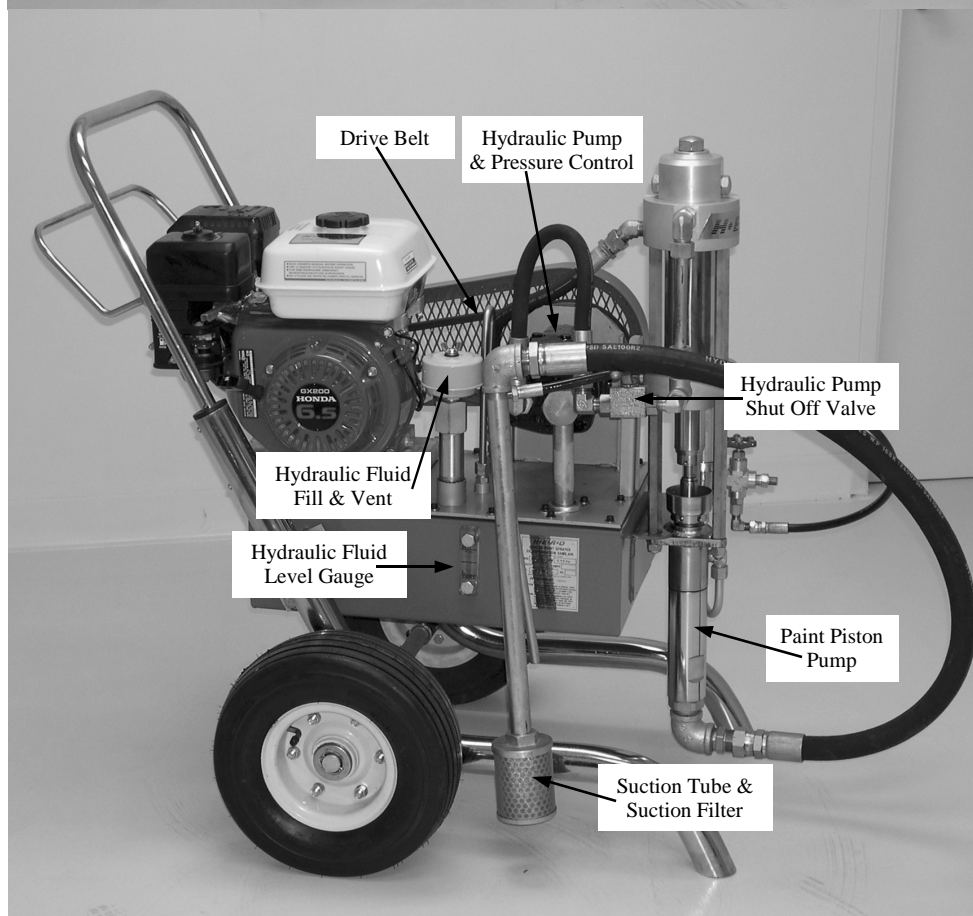
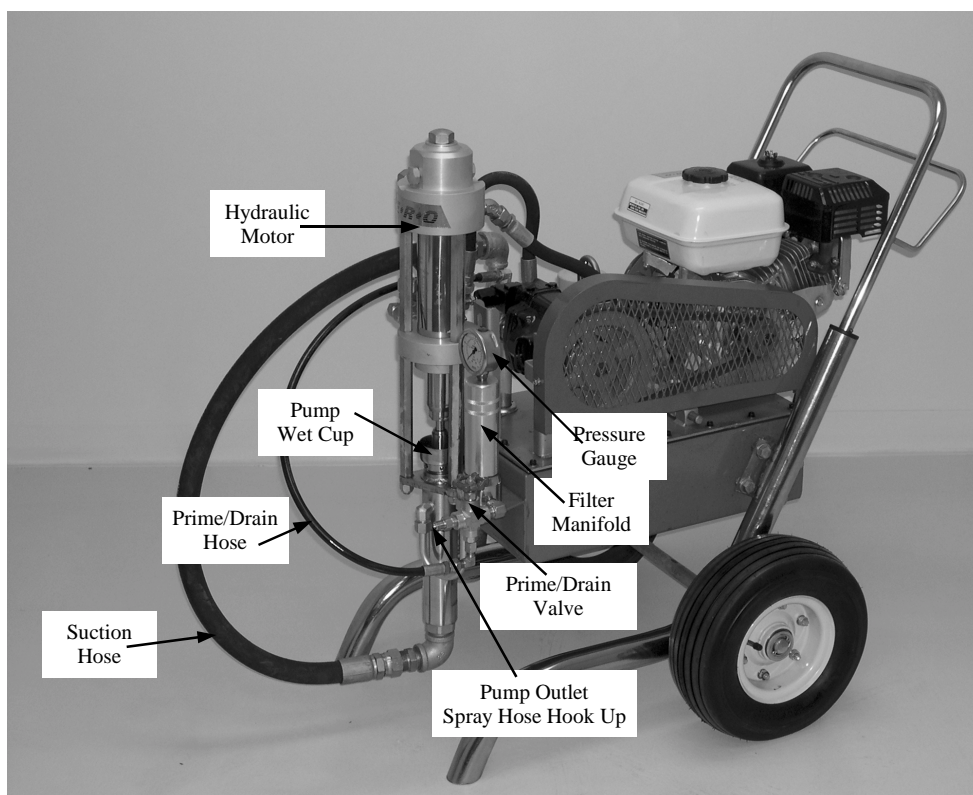

# SAFETY WARNING!

- Use of this high-pressure equipment could result in serious injury and is for professional use only!
- You must operate this equipment only after the instruction manual is clearly understood.
  - Workman and assistant must always wear protective eyewear, gloves, clothing, and respirators as recommended by the material manufacturer.

## GAS / HYDRAULIC POWERED AIRLESS SPRAY PUMPS.

Gas / Hydraulic powered airless spray equipment is an industrial paint sprayer which uses a gas engine to drive a hydraulic pump which in turns produces hydraulic pressure. This pump delivers pressure fluid to a hydraulic motor which drives a high pressure airless piston pump. All of these components make this unit a heavy duty portable airless sprayer which is capable of high volume and high production able to pump and spray light to very high viscous materials. Airless spray is fast, economical and needs no atomizing air.

Airless spray systems use a high pressure pump to supply fluid to the spray tip, where it is atomized by the pressure and sprayed onto a desired surface.

Control of the atomizing pressure is done by regulating the hydraulic fluid pressure in the hydraulic pump. The spray is controlled by triggering a hand gun, or activating the controls of an automated system.

The spray pattern and flow rate is controlled by choosing the spray tip best suited to your needs.

## GENERAL SAFETY WARNING

- High pressure spray can cause serious injury.
- Because of the high pressure and velocity of the fluid being atomized, paint, solvent or other fluids could penetrate through your skin, into your body or eyes.
- Never point the spray gun at yourself or anyone else.
- Never put your hands, fingers or any part of the body over the spray tip/nozzle.
- Even after you shut off the pump, there is still high pressure in the system, You must always follow the “**PRESSURE RELIEF PROCEDURE**” before servicing, or removal of the spray tip/nozzle.

## SPRAY GUN SAFETY WARNING

- **Never** point the gun at yourself or anyone else: This can result in serious injury.
- **Safety latch:** Engage trigger safety latch in the closed or “**LOCK**” Position see FIG 1, whenever you stop spraying, even for a moment. Failure to engage trigger safety latch can result in serious injury.
- **Trigger safety guard:** This prevents the gun from triggering accidentally when it is dropped or bumped. You must not operate without the trigger safety guard.
- **When** cleaning or changing the tips use extreme caution and follow the “**PRESSURE RELIEF PROCEDURE**” then remove the spray tip.
- **Aim** the spray gun into a grounded metal pail using the lowest pressure possible, then trigger the spray gun.
- **If** the fluid sprayed is not diffused into a irregular stream, replace the diffuser at once.
- **If** the spray tip clogs while spraying, engage trigger safety latch in “**SAFE**” position immediately.
- **Never** wipe off around the spray tip until pressure is fully relieved and the trigger safety latch in “**SAFE**” position.

Fig 1

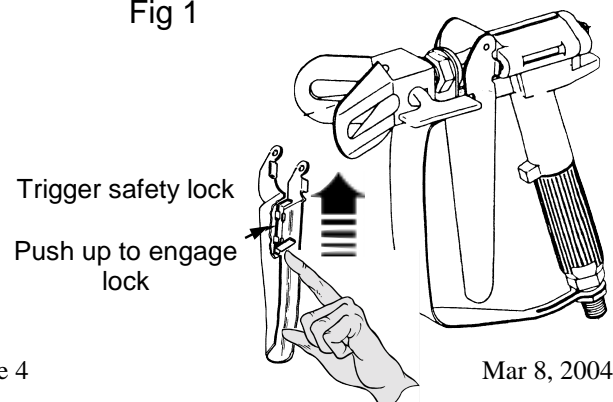

## EQUIPMENT PRESSURE

The HRO ST-3131 pump can develop 3500 P.S.I. (225 Bar) maximum working pressure at Never exceed this maximum pressure to the pump. Exceeding the maximum working pressure can result in serious equipment damage or rupture.

## FIRE OR EXPLOSION WARNING

The flow of fluid through the inside of pump and hose can give occasion to static electricity by the high velocity, so be sure to ground every part of the spray equipment properly. Sparking can ignite fumes from solvents and fluid being sprayed, dust particles and other flammable substances, whether you are spraying indoors or outdoors, It can result in serious bodily injury or property damage. Never plug in or unplug any power supply cords in the spray area where there is any chance of igniting fumes still in the air. If you experience any static sparking or even a slight shock while using this equipment, stop spraying immediately and check the entire system for the grounding situation. Do not use again until the problems have been identified and corrected.

## EQUIPMENT ALTERATION WARNING

Never alter any part of spray equipment or other accessories. Altered or modified. such as over-pressurizing, modifying parts, using incompatible chemicals and fluids including worn or damaged parts can result in malfunction causing serious bodily injury, fire, explosion or property damage. Always check all spray equipment regularly and repair or replace worn or damaged parts without delay. Workman and assistant must always wear protective eyewear, gloves, clothing, and respirator as recommended by the material manufacturer.

## PRESSURE RELIEF PROCEDURE

Always follow "PRESSURE RELIEF PROCEDURE" before servicing, cleaning or removal of the spray tip to prevent serious bodily injury, fluid injection, or splashing in the eyes.

- 1 Engage the spray guns safety latch in "LOCK" position
- 2 Shut off the power to the gas engine.
- 3 Disengage the spray gun safety latch and aim the spray gun into the side of grounded metal pail, and trigger the gun to relieve pressure.
- 1 Re engage the spray gun safety latch in "LOCK" position.
- 2 Open the drain valve to release pressure. Leave drain valve in open position during all service operations.
- 3 Leave drain valve open until you are ready to spray again.

If you feel that the spray tip or hose is completely clogged or pressure has not been fully relieved after following the steps above, remove the tip retaining nut and release pressure gradually.

## HOSE SAFETY

Because of the high pressure in the hoses, if the hose develops a leak, rupture, or other damage, High pressure fluid could penetrate the skin, causing serious bodily injury.

- **Never use damaged hoses.** Before using check the entire hose for cuts, leaks, abrasion, or a bulging cover. If any type of damage is noticed, replace the hose immediately.
- **Spring guard :** Hoses must have spring guard on both ends where easy to damage or wear than other parts.
- **Tighten all fluid connections** securely before use. High pressure fluid can dislodge a loose coupling.
- **Do not pull on hoses to move,** only lift the hoses up to move them.
- **Do not exceed the hoses to temperatures** above 180 degrees F. (82 degrees C.) or below -40 degrees F. (-40 degrees C.)
- **Before using be sure to check a tag on it** which specifies the maximum electrical resistance and do not exceed the recommended limits.
- **Ungrounded or poorly grounded hose** can give way to serious system hazards or fire/explosion hazard.



## GROUNDING SAFETY

Check your local electrical code for detailed grounding instructions for your area and type of equipment and be sure to ground all of this spray equipment as the following.

- 1 Pump : Use a ground wire and ground to a good source such as the building ground source, or drive a steel spike into the ground and attach the ground wire to it.
- 2 Fluid hoses : Use only grounded hoses to a maximum of 500 FT (150M)
- 3 Spray Gun : Connect to a properly grounded fluid hose and pump.
- 5 Object being sprayed & Fluid supply tank : All sources should be grounded.
- 6 Solvent pail : Use only metal pails not plastic or use the pail on a non conductive surface, such as card board or plastic sheeting .

- Filter manifold - Removes and filters out the impurities from the paint before reaching the spray tip.
- Prime valve - Releases fluid pressure from the pump, hoses and guns. Turn counter clockwise to open and clockwise to close.
- Spray Gun Make sure that gun is in good operating condition.

### AIRLESS – SPRAY TECHNIQUE

Good airless-spray technique is much like conventional air spray, except that you hold the gun further from work surface, you get more coating thickness, which results in less pattern overlapping, and you use more positive action when triggering gun.

Hold the gun 10-12 in from the work, the distance varies with the covering ability of the paint, type of surface to be sprayed, and the spray pattern.

## MOVING PARTS SAFETY WARNING

- Moving parts can cause to pinch or seriously injure your fingers or other body parts.
- Keep clear of moving parts when starting or operating the pump and be sure to follow the “Pressure Relief Procedure” to prevent the pump starting accidentally.

## INSTALLATION

*If you have any trouble installing, contact Hero technical service for support or assistance.  
1-800-494-4376*

- Install the correct spray hose and spray tips to suit the type of application.
- All fluid hoses must be properly sized and pressure rated for this equipment.
- Use only grounded fluid hoses.
- Pressure regulator - This controls pump pressure and outlet pressure by adjusting the adjustment knob to the pump.
- Hydraulic shut off valve - This lever type valve shuts off fluid pressure from hydraulic pump.
- Suction tube filter - Removes harmful and coarse materials from entering pump.

## PREPARING PAINT FOR USE.

These are probably the most important steps toward trouble-free spray painting.

- Prepare the paint or other coatings according to the manufacturer’s instructions.
- If the paint has been opened before, the product should be checked to make certain that it has not skinned over .
- Stir paint thoroughly to dissolve hard pigments.
- Strain the paint through a fine nylon mesh bag (available at most paint dealers) to remove particles that may clog filters, or spray tip.
- Follow the paint manufacturer’s recommendation on thinning the material to be sprayed.
- Be careful not to add too much solvent, over thinning paint makes the coating hard to control and reduces its coverage .

## WARNING

**If there are leaks, shut off the pump immediately and release system pressure. Follow the “Pressure Relief Procedure” then tighten connections, start the pump again and check to be sure leaking has stopped.**

**Always use the lowest pressure necessary to get the desired results, Higher pressures waste fluid and cause premature wear of the pump packings and spray tips.**

**Never allow the pump to run dry of the fluid being pumped, because a dry pump will quickly accelerate to a high speed, possibly damage itself. If the pump accelerates quickly or is running too fast, shut off pump immediately and check the fluid supply.**

## KEY POINTS BEFORE STARTING TO SPRAY

- 1 Check the hydraulic fluid level in the tank
- 2 Check the engine oil level.
- 3 Check the grounding of the system to prevent static sparking.
- 4 Flush the system and test for leaks.
- 5 Lubricate the pump with Hero piston lubricant part # 4-02-40-3PL1 in the wet cup.
- 6 Remove and check gun filter, if used, to see that it is clean.
- 7 Closed the prime / drain valve.
- 8 Check the level of paint in the supply container and see that the paint has been thoroughly mixed, and if necessary, thinned.
- 9 Keep the pump, hose and gun clean inside and outside.

## OPERATION

Follow the “**Pressure Relief Procedure**” before operating.

### FLUSHING TO CLEAN SYSTEM

Flush the pump, hose and gun with the solvent as Recommended by your material supplier.

### FLUSH THE PUMP BEFORE STARTING

- 1 Make sure that engine is shut off.  
**WARNING : DO NOT INSTALL THE SPRAY TIP .**
- 2 Connect a suction hose to the pump’s fluid inlet or put in a metal pail containing a gallon of compatible solvents.
- 3 Close the drain valve.
- 4 Hold a metal part of the spray gun firmly against the side of a grounded metal pail and hold the trigger open.
- 5 Turn the switch to the on position and start.
- 6 Very slowly turn the pressure regulator clockwise until the pump starts about 100 P.S.I.
- 7 Cycle the pump slowly until all air is pushed out, and fluid is flowing in a steady stream.
- 8 Release the spray gun trigger and engage the safety latch in the “Lock” position and carefully check all connections in the system for leaks.
- 9 Follow the “Pressure Relief Procedure” and then install the spray tip in the gun.

## WARNING

If there are leaks, shut off the pump immediately and release system pressure follow the “Pressure Relief Procedure” then tighten connections, start the pump again and check to be sure leaking has stopped. Always use the lowest air pressure necessary to get the desired results, Higher pressures waste fluid and cause premature wear of the pump packings and spray tips. Never allow the pump to run dry of the fluid being pumped because a dry pump will quickly accelerate to a high speed, possibly damage itself. If the pump accelerates quickly or is running too fast, shut off pump immediately and check the fluid supply.

## NOTE:

**The pump will stall out (stop) against the pressure without any damage to the pump.**

## SETTING UP TO SPRAY

Always follow the “Pressure Relief Procedure” before cleaning, or removing the equipment or servicing any part of system equipment.

- Immerse the pump intake or suction tube in paint. Make sure drain valve is open.
- Start the engine.
- Open the hydraulic ball valve to allow hydraulic fluid to flow to hydraulic motor.
- Paint pump should start to pump material and you should notice material flowing out to prime valve.
- Let the pump run until the material is flowing evenly out of prime valve.
- Close the prime valve and unit should now build up with pressure.
- Run the pump until paint flows smoothly from the gun, without spitting, release the trigger.
- Adjust the pump to the minimum pressure required to obtain the desired spray pattern of paint. If atomization is not possible on thick paints, thin with the compatible solvent.

- Use the lowest pressure setting possible.
- If the pump accelerates quickly or is running too fast, stop the pump immediately and check the material supply.
- Don't leave a pump shut off for a long period of time, if the material supply has been exhausted and air has been pumped into the lines. This can cause the material possibly to dry in the lines.
- Prime the pump and lines with material or flush and leave filled with solvent, with the pressure relieved.

## MAINTENANCE

### DAILY SHUTDOWN PROCEDURE”

- Close the on-off air valve to the pump.
- Always be sure to stop the pump at the bottom of the stroke to prevent paint from drying on the displacement rod and damaging the throat packings.
- Always bleed off the paint pressure in the system by triggering the gun and opening the drain valve, making sure to have a container ready to catch the paint draining from the drain valve.
- Remove the tip from the gun and clean and leave it in solvent until ready to use again.
- Do not disconnect the gun or hoses, keep the unit filled with solvent to reduce the need for flushing.

## NOTE:

**–When using fast drying paints, immerse the suction tube in a container of solvent during shutdown.  
–Clean the pump's intake screen.**

## SHUTDOWN FOR STORAGE

Always follow the “Pressure Clearance Procedure” and when storing the unit proceed as follows:

- Flush the unit clean, as instructed . It may take repeated flushing with solvent or water, to clean the system thoroughly.
- Fill the pump, hoses, and gun full of solvent. If the flushing solvent used as water or a keytone type solvent, fill the system with mineral spirits or light oil for storage over a long period. Wipe all external wetted parts of the pump with oil. Make sure that water or keytone solvent is removed from the wet cup/ packing nut.



# TROUBLE SHOOTING

TROUBLE	POSSIBLE CAUSE	REMEDY
Pump will not stroke.	<ol style="list-style-type: none"> <li>1. Ball valve on the hydraulic shut off valve not opened to the on position.</li> <li>2. Low or no hydraulic fluid</li> <li>3. Pressure regulator not turned up to high enough pressure.</li> <li>4. Poor or damaged hydraulic pump</li> <li>5. Damaged hydraulic motor</li> <li>6. Paint pump at full pressure.</li> <li>7. Paint pump seized.</li> </ol>	<ol style="list-style-type: none"> <li>1. Turn ball valve to the on position.</li> <li>2. Fill with correct fluid.</li> <li>3. Slowly increase the pressure by turning the regulator knob clockwise.</li> <li>4. Call technical service department.</li> <li>5. Call technical service department.</li> <li>6. Follow "pressure relief instructions"</li> <li>7. Follow pressure relief procedures and check the following; hardened paint in pump.</li> </ol>
Pump stokes, but poor performance.	<ol style="list-style-type: none"> <li>1. Fault in pump section.</li> <li>2. Worn spray tip.</li> <li>3. Improper tip size.</li> <li>4. Material too viscous ( thick ).</li> <li>5. Gun filter and / or pump filter plugged.</li> <li>6. Engine may not be running correctly.</li> <li>7. Fluid section seized by dry paint.</li> </ol>	<ol style="list-style-type: none"> <li>1. Pump may need repair.</li> <li>2. Replace tip.</li> <li>3. Replace tip.</li> <li>4. Thin material with appropriate thinners, per product manufacturer's instructions.</li> <li>5. Clean or replace filter(s).</li> <li>6. Check and choke and throttle positions.</li> <li>7. Clean &amp; rebuild fluid section. See 15-17</li> </ol>
Low or Erratic Output / Pressure	<ol style="list-style-type: none"> <li>1. Air leaks or blockages.</li> <li>2. Worn Upper Packings, Intake or Outgo balls and / or seats.</li> <li>3. Cylinder sleeve leakage.</li> <li>4. Worn spray tip.</li> </ol>	<ol style="list-style-type: none"> <li>1. Check the following;               <ul style="list-style-type: none"> <li>⇒ Intake tube fitting.</li> <li>⇒ Plugged intake screen.</li> <li>⇒ Intake Teflon O-ring.</li> </ul> </li> <li>2. Re-pack pump.</li> <li>3. Replace cylinder sleeve seal ( ref# 15).</li> <li>4. Change tip.</li> </ol>

## WARNING

If there are leaks, shut off the pump immediately and release system pressure follow the “Pressure Clearance Procedure” then tighten connections, start the pump again and check to be sure leaking has stopped.

Always use the lowest air pressure necessary to get the desired results, higher pressure waste fluid and cause premature wear of the pump packing and spray tip.

Never operate the pump to run dry of the fluid being pumped because a dry pump will quickly accelerate to a high speed, possibly damage itself.

If the pump accelerates quickly or running too fast, shut off immediately and check the fluid supply.

## NOTE:

The pump will stall out (stop) against pressure without damage to the pump.

## SPRAY STARTING AND ADJUSTING

Always follow the “Pressure Relief Procedure” before cleaning, , or, removing the equipment or servicing any part of system equipment.

- Immerse the pump intake or suction tube in paint.
- Make sure drain valve is open.
- Let the pump run until it is primed and run until paint flows smoothly out of prime / drain valve.
- Close the prime
- Squeeze the gun trigger and open the on-off air valve gradually at first to from the gun, without spitting, release the trigger and open the pump runaway valve fully.
- Tighten the tip retainer nut with moderate tension only.
- If pattern is not fully atomized, gradually increase the pressure with the pump adjusting nut.
- Adjust the pump to the minimum pressure required to obtain the desired spray pattern of paint. If atomization is not possible on thick paints, thin with the compatible solvent.

- Use the lowest pressure setting possible.
- If the pump accelerates quickly or is running too fast, stop the pump immediately and check the material supply tank.
- Don’t leave a pump shut off if the material supply has been exhausted and air has been pumped into the lines.
- Prime the pump and lines with material or flush and leave filled with solvent, with pressure relieved.

## MAINTENANCE

### DAILY SHUTDOWN PROCEDURE

- Shut off power to engine.
- Close hydraulic ball valve.
- Always bleed off paint pressure in the system by triggering the gun open and opening the drain valve and have a container ready to catch the paint draining from the drain valve.
- Remove the tip from the gun and clean and leave it in solvent until ready to use again.
- Do not disconnect the gun or hoses and keep the unit filled with coating to reduce the need for flushing.

## NOTE:

–When using fast drying paints, immerse the suction tube in a container of solvent during shutdown periods.

–Clean the pump’s intake screen.

## SHUTDOWN FOR STORAGE

Always follow the “Pressure Clearance Procedure” and when storing the unit : proceed as follows.

- Flush the unit clean, as instructed above. Sometimes it takes several flushings, each with solvent, to clean thoroughly.

Flush the pump, hoses, and gun with full of solvent unless the flushing solvent is water or ketone solvent, to remove water or ketone solvent, fill the system with mineral spirits solvent or light oil for long storage periods, and wipe all external wetted parts with oil. Also remove water or ketone solvent used, from exposed part of pump displacement rod.

## FLUSHING PROCEDURE

Follow the pressures relief procedure on page 3.

1. Remove and clean gun filter.
2. Unscrew filter housing retainer (ref# 1) (should be hand tight) and remove and clean filter (ref# 5) thoroughly.
3. Re-install the filter housing and retainer. Flush sprayer without filter screen installed.
4. Close prime valve.
5. Pour a gallon of the correct thinner into a clean 5 gallon pail.
6. Insert the intake tube into the pail.
7. Turn regulator control knob all the way counter-clockwise.
8. Point prime valve bleed tube into 5 gallon pail. Turn the pump ball valve on and slowly increase the pressure until sprayer starts. Open prime valve. Allow thinner to circulate back into the pail for a short period to flush the prime valve.
9. Close the prime valve.
10. While firmly holding a metal part of the gun against a metal waste container, trigger the gun into a separate waste container. Keep the gun triggered until clean solvent is sprayed from the gun. Release the trigger and engage the safety lock.
11. Remove the intake tube from the pail. Trigger the gun once again to discharge thinner from the hose. Do not let the pump run dry for more than a couple of minutes or damage to the pump packing could result.
12. Unscrew filter housing retainer and re-install the filter screen.
13. Repeat steps 3-9 with clean solvent.
14. Turn the ball valve off, and open the prime valve.

**NOTE:** Filter housing retainer (ref# 1) only has to be hand tight.

**NOTE: NEVER LEAVE THE UNIT UNDER PRESSURE WHEN NOT SPRAYING ( MOTOR TURNED OFF ). RELIEVE PRESSURE BY TRIGGERING GUN.**

**NOTE: TO PREVENT CORROSION AND TO REDUCE THE RISK OF FLUID FREEZING IN THE PUMP.**

***NEVER STORE THE UNIT WITH PAINT OR WATER IN THE PUMP SYSTEM, EVEN OVERNIGHT!***

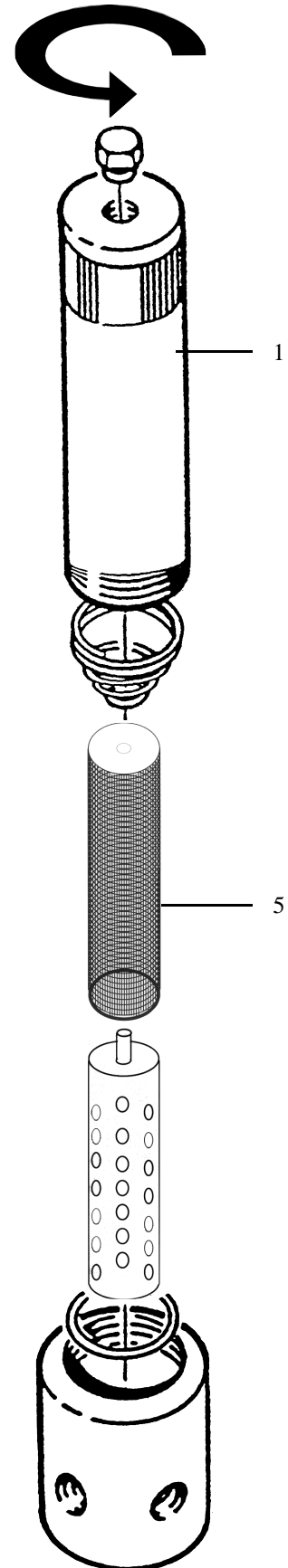

*Manufactured by:*  
**H.E.R.O. INDUSTRIES**  
**2719 LAKE CITY WAY**  
**BURNABY, B.C.**  
**CANADA**

**Phone:**                   604-420-6543  
                                  800-494-4376  
**Fax:**                     604-420-8725

*Purchased From*

---

---

---

---

**Model:** \_\_\_\_\_

**Serial #:** \_\_\_\_\_

**Date of Purchase:**

---

## Free Manuals Download Website

<http://myh66.com>

<http://usermanuals.us>

<http://www.somanuals.com>

<http://www.4manuals.cc>

<http://www.manual-lib.com>

<http://www.404manual.com>

<http://www.luxmanual.com>

<http://aubethermostatmanual.com>

Golf course search by state

<http://golfingnear.com>

Email search by domain

<http://emailbydomain.com>

Auto manuals search

<http://auto.somanuals.com>

TV manuals search

<http://tv.somanuals.com>