

**PARTS & SERVICE  
MANUAL**

**FLAKER DISPENSER  
FD 550A, FD 550W**



*Icemakers & Dispensers*

**MILE HIGH EQUIPMENT CO.**

**11100 E. 45TH AVE.  
DENVER, COLORADO 80239  
(303) 371-3737**

JULY 1983

P/N 9081041-01

**MILE HIGH EQUIPMENT COMPANY  
ICE MACHINE TWO-YEAR PARTS WARRANTY  
To the original owner of an ICE-O-MATIC MACHINE.**

We warranty every Ice-O-Matic Ice Machine to be free from defects in material and factory workmanship if properly installed, cared for and operated under normal conditions with competent supervision. **WITHIN TWO YEARS FROM DATE OF ORIGINAL INSTALLATION WHEN REPORTED ON A WARRANTY CARD RETURNED TO THE FACTORY** we will replace, F.O.B. our plant, Denver, CO, or F.O.B. authorized Mile High Equipment Co. Parts Depots, without cost to the customer, that part of any such machine that becomes defective, BUT no part or assembly which has been subject to any alteration or misuse, accident, or is from a machine on which the serial number has been altered or removed. We will also honor warranty for **27 MONTHS (THIS TWO YEAR WARRANTY SHALL APPLY TO MACHINES SHIPPED ON OR AFTER JANUARY 1, 1978)** from date of shipment whichever period is last to expire, provided in either such case installation of the equipment is reported on warranty card and returned to the factory at the time of installation. After thorough examination, the decision of our Service Department shall be final. Any defective parts to be repaired or replaced must be returned to us, transportation charges prepaid, and they must be properly sealed and tagged. The serial and model number of the machine, and the date of original installation of such machine must be given. We will not, however, assume any responsibility for any expenses (including labor) incurred in the field incidental to the repair or replacement of equipment covered by this warranty. Our obligation hereunder to repair or replace a defective part is the exclusive remedy for breach of this warranty; and we will not be liable for any other damages or claims, including consequential damages.

No representative, dealer, distributor or any other person is authorized or permitted to make any other warranty or obligate MILE HIGH EQUIPMENT COMPANY, to any liability not strictly in accordance with this policy. **THIS WARRANTY IS IN LIEU OF ALL OTHER WARRANTIES EXPRESSED OR IMPLIED, INCLUDING ANY WARRANTY OF MERCHANTABILITY, AND OF ALL OTHER OBLIGATIONS OR LIABILITIES ON OUR PART.**



*Icemakers & Dispensers*

A SUBSIDIARY OF WELMOORE INDUSTRIES, INC.

**MILE HIGH EQUIPMENT COMPANY  
LIMITED ICE MACHINE FIVE-YEAR WARRANTY  
For Motor Compressor**

On the said ICE-O-MATIC Ice Machine, we warrant to the original purchaser for a period of five years following the date of installation, the repair or replacement of the motor compressor only if it is shown to our satisfaction that the motor-compressor is not operative due to defects in factory workmanship or material as originally supplied and that normal use and reasonable care have been exercised. We will not, however, assume any responsibility for any expenses "including labor" incurred in the field incidental to the repair or replacement of compressor covered by this warranty. Our obligation hereunder to repair or replace the motor compressor is the exclusive remedy for breach of this warranty; and we will not be liable for any other damages or claims, including consequential damages.

This warranty does not apply to destruction or damage caused by alterations by unauthorized service, using other than identical replacements, risks of transportation, accidents, misuse, abuse, damage by fire, flood or acts of God. After thorough examination, the decision of our Service Department shall be final.

No representative, dealer, distributor or any other person is authorized or permitted to make any other warranty or obligate MILE HIGH EQUIPMENT CO., to any liability not strictly in accordance with this policy. **THIS WARRANTY IS IN LIEU OF ALL OTHER WARRANTIES EXPRESSED OR IMPLIED, INCLUDING ANY WARRANTY OF MERCHANTABILITY, AND OF ALL OTHER OBLIGATIONS OR LIABILITIES ON OUR PART.**



*Icemakers & Dispensers*

A SUBSIDIARY OF WELMOORE INDUSTRIES, INC.

## TABLE OF CONTENTS

	Page
FOREWORD.....	1
GENERAL DESCRIPTION FLAKED ICE MACHINE .....	2
SERVICE AND MAINTENANCE RECORD.....	3
GENERAL INSTALLATION INSTRUCTIONS .....	4
SPECIFIC INSTALLATION INSTRUCTIONS .....	6
Dimension and Connection Diagram .....	7
GENERAL MAINTENANCE INSTRUCTIONS .....	8
Auger Cleaning Procedure — air and water .....	9
Bin Cleaning Procedure .....	10
GENERAL SERVICE INFORMATION .....	11
Water System Description .....	11
Refrigeration System Description .....	12
Automatic Expansion Valve.....	13
Wiring Diagram .....	14
To Replace Evaporator .....	15
To Replace Seal, Run a Leak Check .....	16
Bin Control Adjustment .....	17
Timer Adjustment .....	18
Service Diagnosis .....	19
PARTS SECTION .....	22

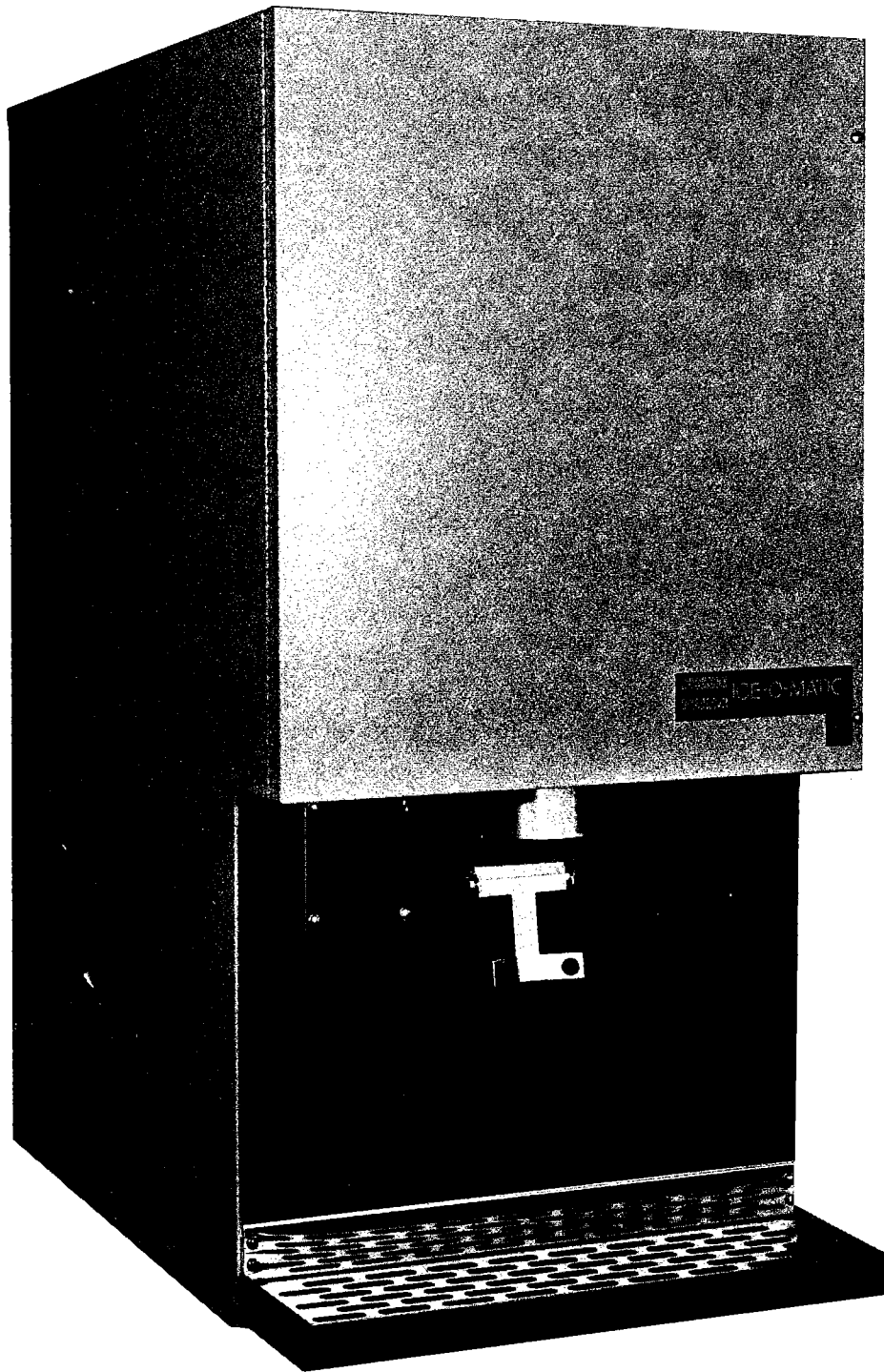

## FOREWARD

We, MILE HIGH EQUIPMENT CO. present this service manual to aid the service men and users in the operation, maintenance, and installation of your equipment.

If, at any time, you encounter conditions that are not answered in this manual, write to the service department of MILE HIGH EQUIPMENT CO. explaining the conditions in detail, giving THE MODEL NUMBER AND SERIAL NUMBER of the unit, and we will give your questions our immediate attention and reply.

MILE HIGH EQUIPMENT CO.  
11100 E. 45th Avenue  
Denver, Colorado 80239  
(303) 371-3737

# GENERAL DESCRIPTION

The Ice-O-Matic Flaked Ice Machine consists of a hermetically sealed refrigeration system for freezing ice in a cylinder. Water is fed into the cylinder where it freezes against the wall and is then chipped off the wall by an auger. This machine is equipped with a thermostatic device that automatically shuts the refrigeration off when the bin is full of ice.

All components are made readily accessible by removing the front, side and back panels. The entire machine was designed for greatest convenience to the operator as well as the service man. The unit requires an absolute minimum of floor or counter space. The water inlet and outlet, incorporating standard pipe fittings, are conveniently located at the back of the cabinet.

The machine is completely wired for connection to a single phase A.C. electrical supply. Use recommended size fuse protection on an individual circuit to this machine. All connections should be made in accordance with local existing electrical codes.

The storage bin is type 304 stainless steel. All outside metal is made of a specially treated steel for a long lasting paint finish, or 300 series stainless steel.

The Ice-O-Matic Dispenser is designed to provide a varying amount of ice. Selection of the amount of desired ice can be accomplished by placing the portion toggle switch in 2 oz., 4 oz., or continuous position.

Having selected the amount of ice desired, ice can now be automatically dispensed without further adjustment of any other control simply by pushing in on the dispenser level.

**NOTE: When filling a glass or pitcher, do not place the container directly under the ice chute or front panel. The lip of the container should never be less than 1 inch below the front panel while ice is being dispensed. This is of utmost importance to insure that proper dispensing of ice is obtained.**

When the portion control selector switch is set at the 2 oz. serving, the dispense auger motor will run for approximately 1 second when the dispense switch is activated.

When the portion control selector switch is set at the 4 oz. serving, the dispense auger motor will run for approximately 2 seconds when the dispense switch is activated.

**NOTE: The volume of ice dispensed can be increased or decreased by adjustment of the timer located inside the control box.**

When the portion control selector switch is set at the continuous position, ice will continue to dispense until the dispense switch is released.

**NOTE: The dispenser is equipped with a safety interlock switch to prevent the operation of the dispense system when the front hinged panel is open.**

# SERVICE AND MAINTENANCE RECORD

Date Purchased \_\_\_\_\_

Date Installed \_\_\_\_\_

Model Number \_\_\_\_\_

Serial Number \_\_\_\_\_

Service Policy Number \_\_\_\_\_

Have you filled out and mailed in the warranty card?

## Service and Cleaning Record

Date	Maintenance Performed	By Whom

# GENERAL INSTALLATION INSTRUCTIONS

## I. UNCRATING:

- A. Check crate carefully for any signs of shipping damage.
- B. Remove crate:
  - 1. Cut banding from around crate.
  - 2. Carefully remove staples from bottom of crate.
  - 3. Lift crate straight up, off entire unit.
  - 4. Check cabinet for signs of shipping damage.
- C. Remove skid from bottom of unit.
  - 1. Remove skid bolts (3/4" wrench), being careful **NOT** to tip unit toward rear and damage bin drain. The removal is best accomplished by raising the unit straight up, removing bolts, and then lifting the unit off the skid.
- D. Install legs. The machine should be raised off the floor 8" to permit bolting on the legs, or tip the cabinet to the **front** onto a pad. Be sure legs are secured tight to cabinet.
- D. Remove panels and perform the following:
  - 1. Check for broken or damaged refrigeration lines.
  - 2. Remove tape and packing from float.
  - 3. Remove shipping brace from rear of chassis.

## II. INSTALLING (All installation should conform with local codes):

- A. Connect the water inlet fitting to a fresh, cool water supply (20 to 60 p.s.i. pressure). Hold the pipe fitting with a small pipe wrench so that the tube inside will not be twisted. Install a shut off valve in an accessible place between the machine and the water supply. In some locations, due to poor water conditions, a strainer should be installed in the water inlet line. If water pressure exceeds 60 p.s.i., a water pressure regulator should be installed in the water inlet line.
- B. Connect the bin drain, evaporator drain, and condenser drain (water cooled units only), to well pitched drain lines. Run all lines separately to an open or trapped drain.
- C. Electrical Instructions (all wiring must conform with existing electrical codes).

This ice machine is completely wired to the junction box on the back of the cabinet for connection to a standard electrical circuit (as indicated on the serial plate and the tag on the junction box) and it is recommended that a separate electrical circuit be provided for the ice machine.

This is of the utmost importance. Long lines with other appliances or loads often result in trouble due to low line voltage. Be sure that electrical power supply is within 10% of required voltage as greater variation will cause motor trouble.
- D. Machine should not be installed in area where ambient temperatures get below 50° F or above 100° F.



# GENERAL INSTALLATION INSTRUCTIONS CONTINUED

- E. Place machine in permanent location maintaining a minimum of 4" from wall to back of ice machine, and with no obstructions to prevent proper ventilation on any side.
- F. Level ice machine by adjusting the leveling screws on the legs.
- G. Check to see that the condenser fan blade turns freely.
- H. Turn "on/off" switch located on electrical control box to the "on" position for thirty seconds to check auger motor. If machine does not operate, check electrical connections. Check bin control. If fan runs and compressor and auger motor does not, check safety control.
- I. Turn water supply on. Check water flow to the evaporator through clear plastic tubing. Check operation of float valve.
- J. Turn "on/off" switch to "on" and wait approximately five (5) minutes for ice to start dropping into ice bin.
- K. Check for water leaks and excessive machine noise before replacing front panel.
- L. Instruct people who will be using the machine how to operate it and how to clean the condenser fins.
- M. **FILL OUT INSTALLATION AND WARRANTY CARDS.**

SERIAL NUMBER	MODEL NUMBER	COMPRESSOR SERIAL NO.	CUSTOMER NUMBER	INVOICE NO.
---------------	--------------	-----------------------	-----------------	-------------



## WARRANTY REGISTRATION CARD

MILE HIGH EQUIPMENT COMPANY  
11100 E. 45th Ave., Denver, CO 80239  
Phone: (303) 371-3737

**DATE INSTALLED** — Month \_\_\_\_\_ Day \_\_\_\_\_ Year \_\_\_\_\_

To establish warranty benefits, this registration card must be filled out and returned to our factory within (10) days after installation. Complete warranty benefits and requirements are so specified in the service and replacement parts manuals. Warranty covers the replacement of defective parts furnished by our factory — but does not include labor or transportation charges that might be involved.

**AGENT**

NAME \_\_\_\_\_  
ADDRESS \_\_\_\_\_  
CITY \_\_\_\_\_  
STATE \_\_\_\_\_ ZIP \_\_\_\_\_

**END-USER**

NAME \_\_\_\_\_  
ADDRESS \_\_\_\_\_  
CITY \_\_\_\_\_  
STATE \_\_\_\_\_ ZIP \_\_\_\_\_

New Installation

FACTORY-WHITE,

Replacement Sale

AGENT, FACTORY - YELLOW

Lease Sale

FILE-PINK

# SPECIFIC INSTALLATION INSTRUCTIONS

Follow General Installation Instructions, then proceed with the following:

Allow machine to run for one (1) hour.

Check dispense system:

- a. Operate the machine on all three portion settings. (If portions are not correct, see Page 18).
- b. Check the dispense chain for tightness.
- c. Check for excessive noise during dispense cycle.

# SPECIFIC INSTALLATION INSTRUCTIONS

## DIMENSION AND CONNECTION DIAGRAM

**AIR  
COOLED  
Pounds  
per  
24 Hours**

**CHASSIS**

**WATER  
COOLED  
Pounds  
per  
24 Hours**

### INCOMING WATER TEMPERATURE

	80	70	60	50
70	511	527	547	550
80	480	501	520	538
90	450	471	493	511

AMBIENT AIR TEMPERATURE

**550**

	80	70	60	50
70	567	595	629	643
80	528	561	592	618
90	490	522	552	577

Refrigerant Charge  
FD550-Air Cooled 20 oz.  
FD550-Water Cooled 22 oz.

### DIMENSIONS (Inches) & PLUMBING/ELECTRICAL CONNECTIONS DIAGRAM:

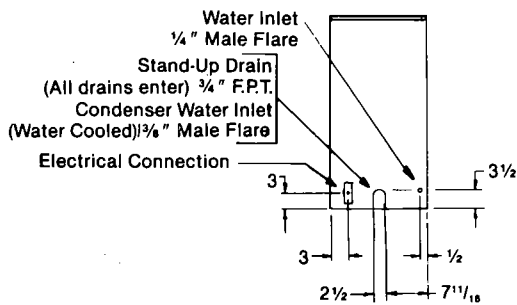
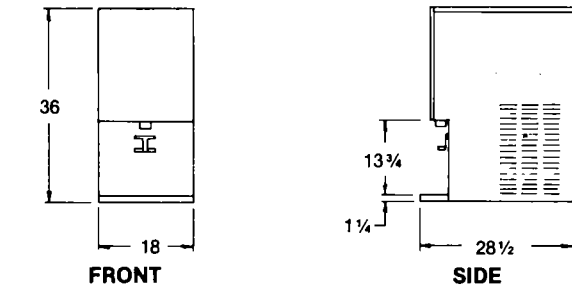

REAR

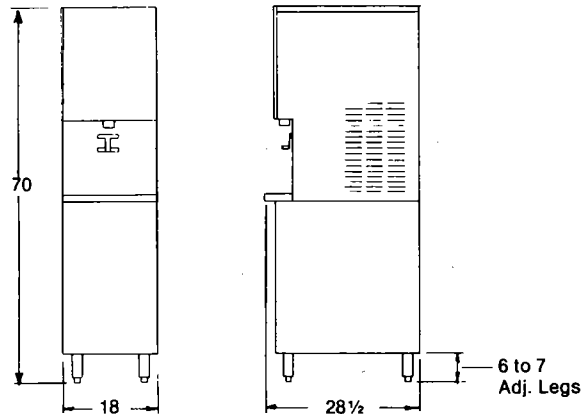

FRONT

SIDE

Floor Model

### SPECIFICATIONS:

Model Number	Lbs. Ice 70° Air 50° Water	Bin Storage Lbs.	Dis- pensing Rate	Electricals 60 Hz., Single Phase			Refrigerant		
				Comp. HP	Volts	Total Amps*	Fuse Sizing	Type	Control
FD-550-A	550	30	2 oz., 4 oz., or	1/2	115	16.1	20	R-12	Auto- matic Expan- sion Valve
FD-550-W	643	30	Continuous Flow	1/2	115	15.0	20	R-12	

Refer to  
Ice-O-Matic  
Machine Stand  
Spec Sheet for  
Floor Model  
Configuration

Select Machine  
Stand  
Model MS-FD

\*Total nameplate rated amperage at voltage specified

# GENERAL MAINTENANCE INSTRUCTIONS

To insure economical, trouble free operation of your ice machine, it is recommended that the following instructions be followed every three months:

## DISCONNECT ALL POWER BEFORE PROCEEDING

1. Remove all panels.
2. Depress float in water reservoir to check adequate flow of water to reservoir.
3. Clean condenser to insure air passage across the condenser fins.
4. Check for leaks of any kind; water, refrigerant, oil, etc.
5. Check all electrical connections.
6. Clean ice maker as per evaporator auger cleaning instructions.
7. Clean out and sanitize bin.
8. Activate dispense mechanism on all settings checking the accuracy of the ice portions. Check the dispense water pressure and clean the water strainer (located before the water regulator).
9. Check and adjust chain tension. Chain should be fairly tight. The adjustment is made by loosening the four (4) gear motor bolts and moving the motor.
10. Check that all sprockets are in alignment.
11. Check for excessive noise during dispense cycle.
12. Replace all panels.
13. Check bin control by placing ice on the bin rod in the bin. It should shut off compressor, fan and auger motor.

## WATER TREATMENT

Water quality varies from location to location, from season to season and from day to day. Most city water being supplied contains solids and chemicals that tend to decrease the performance and life expectancy of the ice machine.

The end product can only be as good as the raw materials, therefore, it is recommended that a local water treatment company be contacted for filtering recommendations at your location. Some of the most common conditions and causes are:

### CONDITION

Water has a metallic taste.  
Water has scent of rotten eggs.  
Soft ice.  
Stainless steel bin liner appears rusty or stained.

### PROBABLE CAUSE

High iron or acid content.  
High sulphur content.  
High solid mineral content.  
High chlorine content.

# GENERAL MAINTENANCE INSTRUCTIONS

## CONTINUED

### EVAPORATOR

#### AUGER CLEANING PROCEDURE

**NOTE:** The importance of cleaning the auger regularly cannot be over-emphasized. An auger that has deposits on it can put excessive pressure on the auger assembly as well as reduce the ice production capacity. The auger should be cleaned at least every 3 months and more often in areas that have severe water conditions. It may be necessary to observe the auger during the first few months of operation to determine the required frequency of cleaning. The auger should be free of any discoloration. Noise coming from the auger is an indication that it needs cleaning. The clear plastic float chamber also indicates the condition of the auger.

Prior to any cleaning —

1. Remove all ice from the storage bin to prevent contamination or,
2. Provide a sanitary container to catch all ice produced during the cleaning and for 30 minutes afterward.

Ice produced during and immediately after cleaning will have an acid taste and **must be disposed of**.  
THE FOLLOWING STEPS SHOULD BE TAKEN IN AUGER CLEANING PROCEDURE

#### AIR COOLED

1. Turn external electrical power supply to ice maker off.
2. Remove side panels.
3. Turn off external water supply to ice maker.
4. Drain evaporator and float reservoir by removing water feed line from float and draining into a container.
5. Replace water feed line to float reservoir.
6. Mix ice machine cleaning solution (one gallon of water to 2 oz. of ice machine cleaner). **Do not use a solution stronger than recommended.**
7. Fill float reservoir with solution.
8. Replace panels.
9. Turn on external electrical power supply.
10. Allow machine to run five (5) minutes before adding additional cleaning solution.
11. Repeat steps 1, 2, 7, 8 and 9 until the one gallon of solution has been used.
12. Turn external electrical power supply to ice maker off and repeat steps 2, 4 and 5.
13. Replace panels.
14. Turn external electrical power on.
15. Turn external water supply to ice maker on.
16. Allow machine to continue running and dispose of all ice made in the first 30 minutes of operation.

#### AUGER CLEANING PROCEDURE

#### WATER COOLED

Use the same procedure as Air Cooled models except:

Do not turn external water supply off. Instead use a piece of wire holding the float ball in the water reservoir up preventing any water from entering the reservoir during cleaning operation.

# GENERAL MAINTENANCE INSTRUCTIONS

## CONTINUED

### TO REMOVE DISPENSE AUGER AND AGITATOR FOR BIN CLEANING

**WARNING:**

**NEVER OPERATE YOUR DISPENSER WITH THE BIN DOOR REMOVED.**

1. Dispense all ice from the storage bin.

**DISCONNECT ALL POWER BEFORE PROCEEDING**

2. Turn on-off switch to "OFF" position.
3. Open front hinged panel.
4. Remove bin door by removing two (2) thumb screws holding the bin door in place.
5. Remove agitator.
6. Slide auger forward into dispense tunnel until the hub of the auger is free from the drive shaft and lift the rear of the auger upward.

This gives complete access to the bin interior for cleaning as well as the parts which you removed.

For reassembly, reverse the procedure.

### PREPARING MACHINE FOR PERIOD OF INOPERATION OR STORAGE

**DISCONNECT ALL POWER BEFORE PROCEEDING**

Shut water off to the machine. Turn toggle switch to "OFF" position.

Let machine stand for 1/2 hour to let ice melt in auger assembly.

Disconnect water feed line from float assembly.

Drain complete system and do not replace the tube. Wipe out storage bin.

# GENERAL FLAKER SERVICE INFORMATION

## WATER SYSTEM DESCRIPTION

The water system on the flakers consists of a float operated valve that maintains the water level in the evaporator just below the ice discharge opening and above the top of the freezing chamber. Water cooled units have a regulating valve, to meter the water to the water cooled condenser to maintain a predetermined head pressure on the high side of the refrigeration system. To adjust the float water level, loosen the two (2) screws on the adjustable float tank bracket and move up or down accordingly.

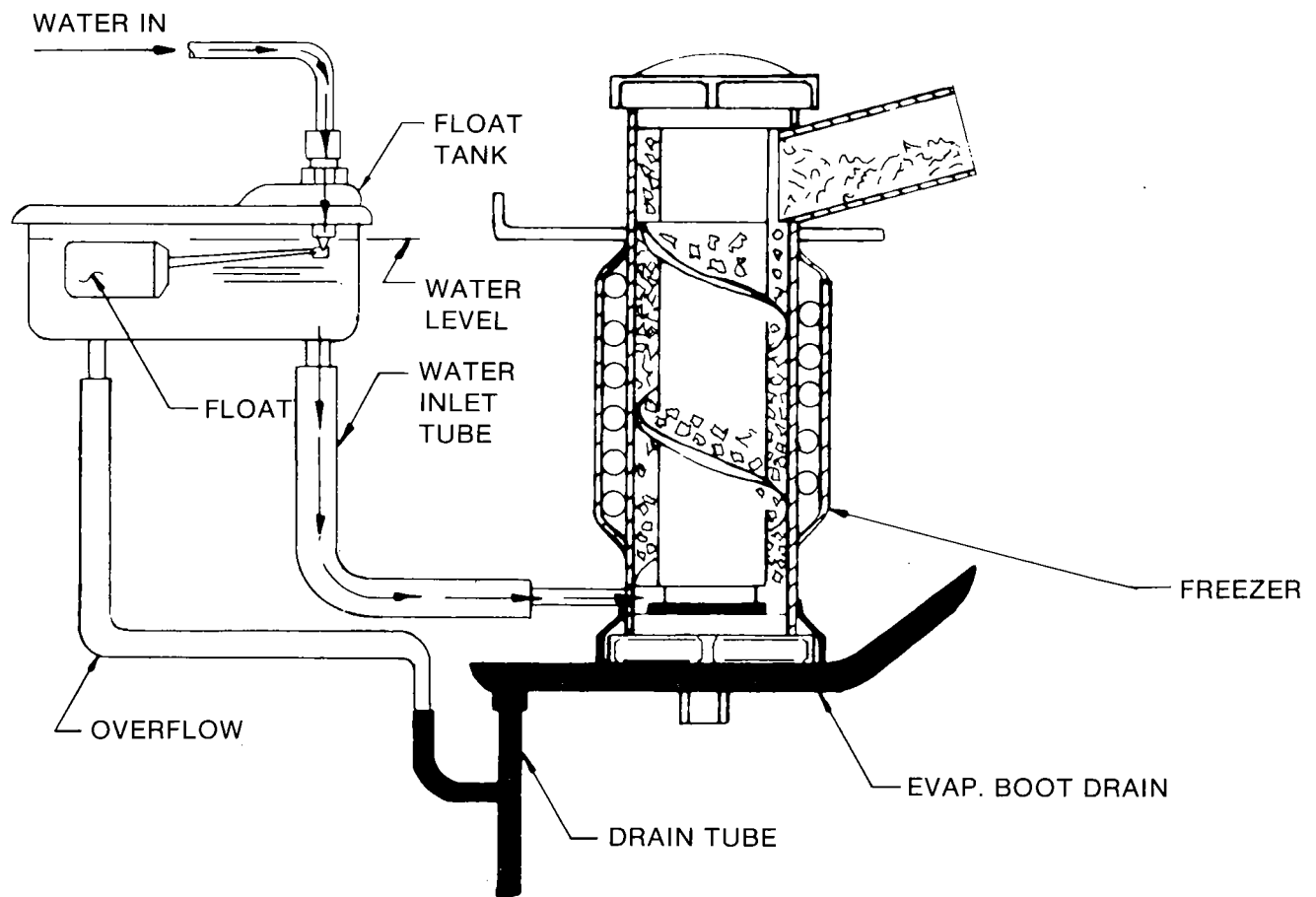

# GENERAL FLAKER SERVICE INFORMATION

## CONTINUED

### REFRIGERATION SYSTEM DESCRIPTION

The refrigeration system consists of the motor compressor, the condenser, which can be either air or water cooled; the refrigerant, the heat exchanger, the refrigerant drier, the automatic expansion valve, which meters the refrigerant to the evaporator maintaining a constant pressure and temperature in the freezing chamber; and the freezing chamber.

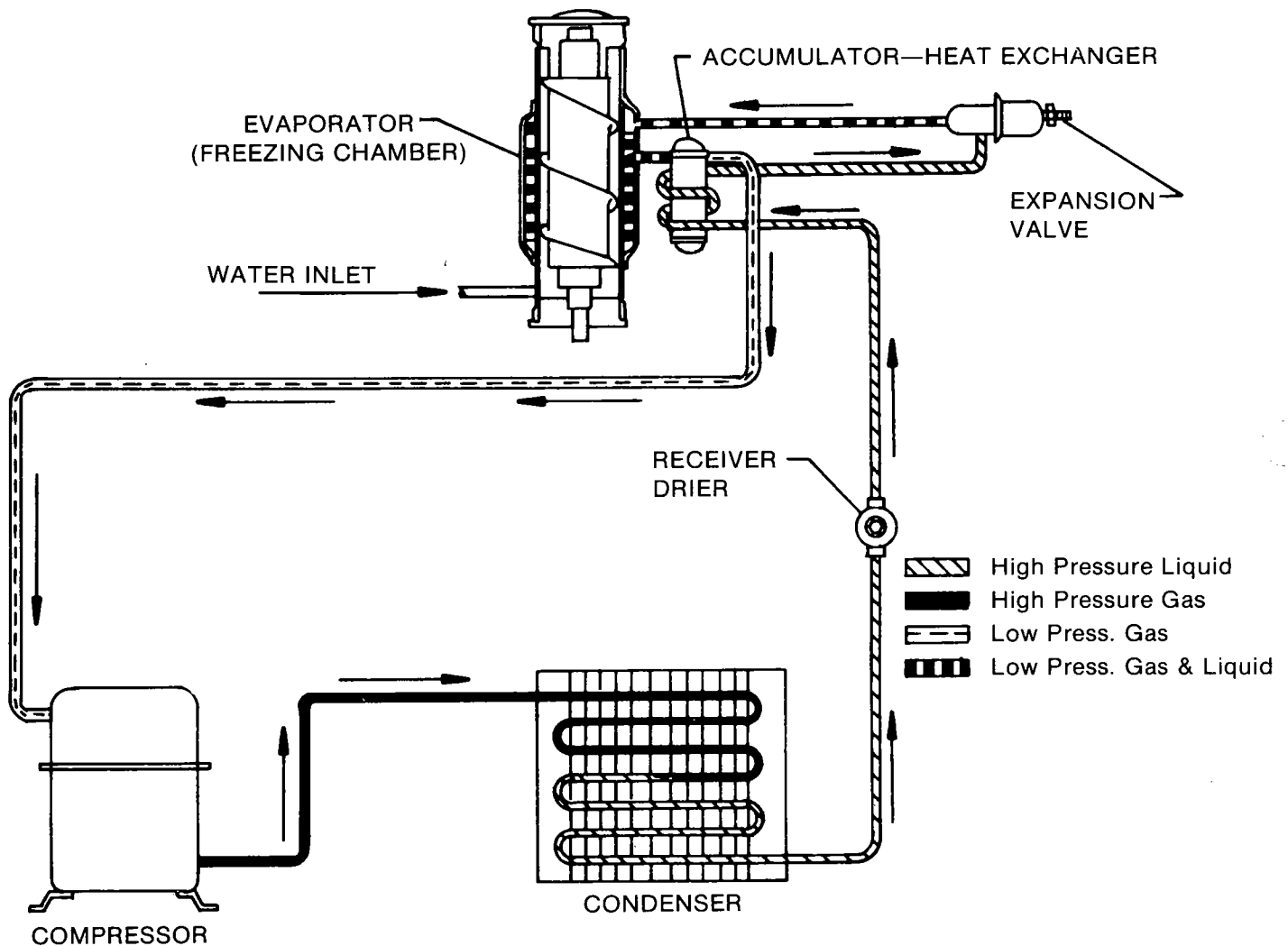

### REFRIGERATION CYCLE



# GENERAL FLAKER SERVICE INFORMATION

## CONTINUED

### AUTOMATIC EXPANSION VALVE

The automatic expansion valve is designed to meter refrigerant to the evaporator by maintaining a constant pressure.

The diaphragm has pressure exerted on the top side by the diaphragm spring and by the atmospheric pressure. This is opposed by the valve needle spring and evaporator pressure. The stainless steel push rod transfers the movements of the diaphragm to the valve needle.

The valve needle is a stainless steel ball that eliminates sticking and insures smooth action. Because the diaphragm employs atmospheric pressure, additional adjustment may be necessary at location by means of the adjusting screw.

The back pressure setting is shown on chart below. This pressure should give no live frost on the suction line on the compressor.

#### **EXPANSION VALVE SETTING. 11 - 12 p.s.i.g.**

Adjustment of back pressure is essential in order to obtain a good "dry" dispensing ice. Wet ice can cause undue abuse to the dispensing mechanism and unnecessary jam ups.

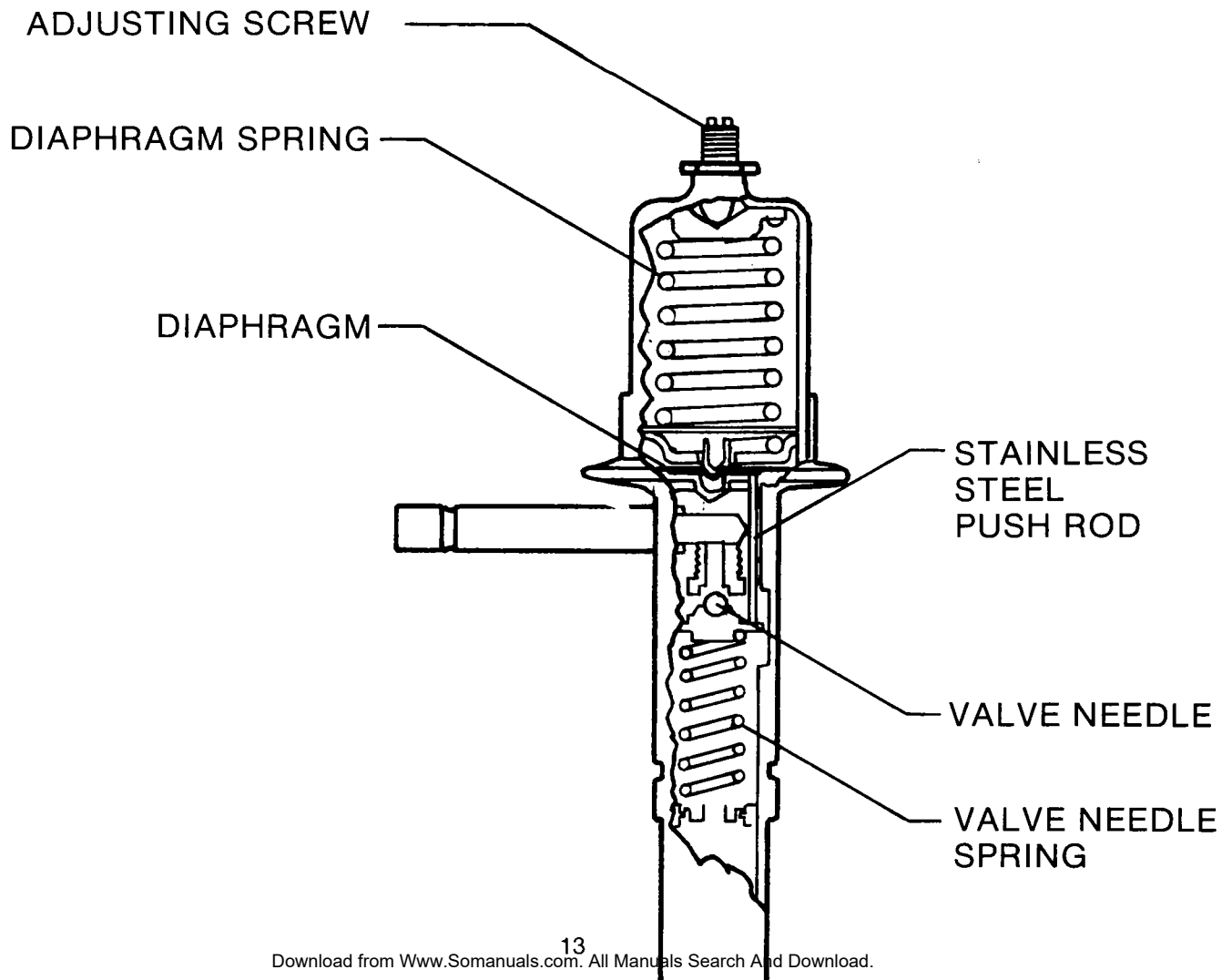

# GENERAL FLAKER SERVICE INFORMATION

## CONTINUED

### WIRING DIAGRAM 115 VOLT

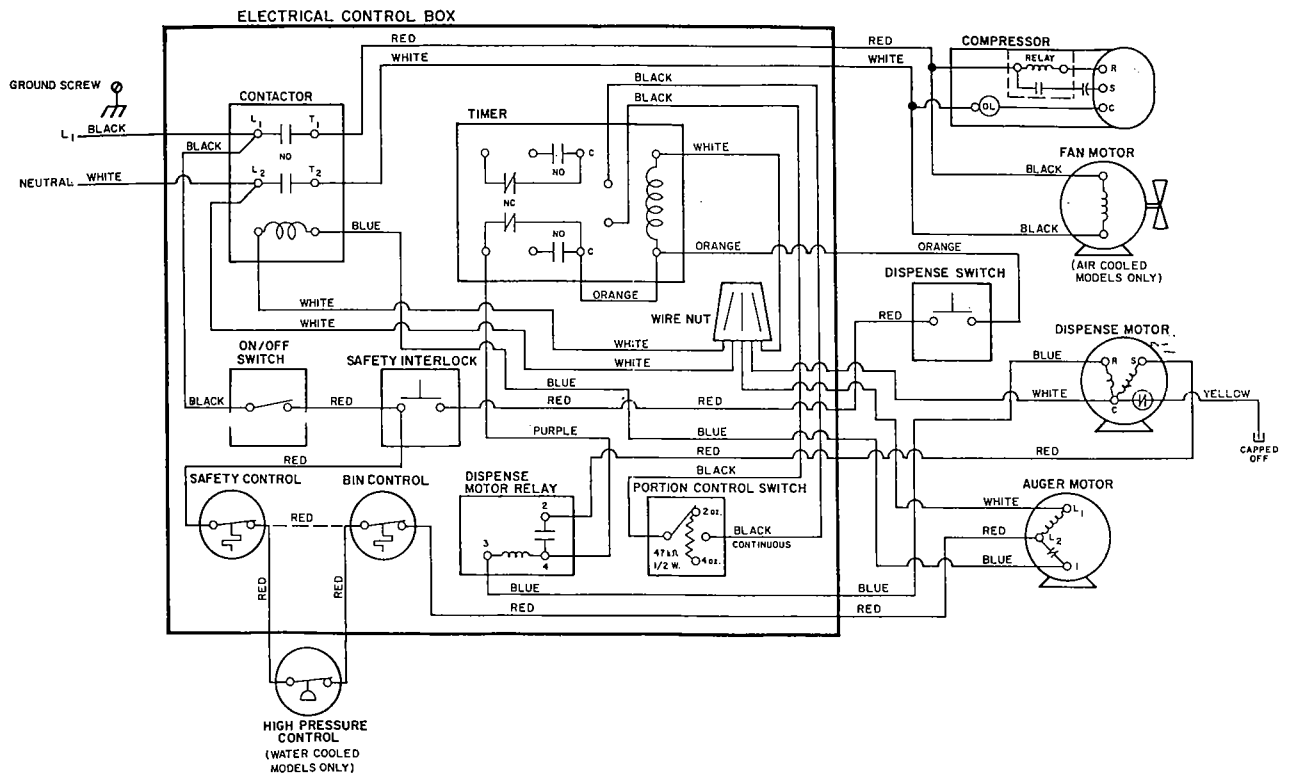

# GENERAL FLAKER SERVICE INFORMATION

## CONTINUED

### TO REPLACE EVAPORATOR

1. Remove panels.
2. Disconnect water inlet tube from evaporator.
3. Disconnect drain tube from evaporator.
4. Remove safety control cap tube from well on lower section of evaporator.
5. Remove upper auger nut.
6. Loosen set screw in the upper part of drive coupling at bottom of auger. Insert screwdriver in coupling under fiber spider and pry up until auger can be lifted from the top of the evaporator assembly.
7. Purge refrigerant from system and disconnect suction line and liquid line.
8. Remove two bolts holding evaporator to frame and lift out evaporator shell assembly.
9. Remove drain boot by pressing down on one side.
10. Remove lower nut from evaporator shell assembly.
11. Remove lower bearing housing assembly by driving lightly against the bearing (NOT THE SEAL). Use 1-1/8" by 12" wooden driving rod for best results.
12. Reassemble by reversing procedure outlined here, and charge with proper charge as indicated on name plate, after completely evacuating system.

# GENERAL FLAKER SERVICE INFORMATION

## CONTINUED

### TO REPLACE SEAL

1. Remove panels.
2. Remove water line to evaporator.
3. Unscrew upper evaporator nut.
4. Loosen set screw in top half of drive coupling. Pry auger up with screwdriver under spider in coupling until auger can be removed from top of evaporator.
5. Remove gear reducer.
6. Remove drain boot.
7. Unscrew bottom bearing assembly.
8. Remove bottom bearing assembly.
9. Remove the rubber part of the seal by hand pressure. Use a screwdriver to pry out the metal seal retainer ring (it is pressed in at the factory). Clean the housing in preparation for installation of new seal.
10. Care should be taken when installing the new retainer ring to see that it goes into bearing housing straight. Do not try to tap it in with a hammer. The steady pressure of a vise is desirable. Lubricate freely with standard cup grease for better installation results.
11. Part of the seal (a bronze and hard rubber assembly) is assembled to the auger itself. This should be replaced by using hand pressure.
12. For reassembly, reverse the procedure.

### **RUN A LEAK TEST. CAUTION.**

The insulation as used on the evaporator of the dispenser carries a freon expanding agent. Caution must be exercised with any leak detector, as breaking the surface of bubble of the insulation will produce a simulated leak. Consequently, when it has been determined that a refrigerant leak exists on the system and that it is not located on any portion of the *exposed tubing*, it will be necessary to proceed slowly in removing the insulation allowing enough time for the vapor to dissipate before leak testing. In some instances, it may even be necessary to expose the entire tubing and freezing cylinder and use a soap bubble solution to make a satisfactory test.

# GENERAL FLAKER SERVICE INFORMATION

## CONTINUED

### ADJUSTMENTS BIN & SAFETY CONTROL

When a unit is installed it is sometimes necessary to make internal adjustments of the range screw. In most cases, however, the **external adjustment** will be adequate and **NO INTERNAL ADJUSTMENT MUST BE MADE. \*\*BEFORE ANY INTERNAL ADJUSTMENTS ARE MADE — ADJUST CONTROL EXTERNALLY.** If conditions require, proceed with the following settings for internal adjustment of range screw.

SETTINGS				SETTINGS			
BIN CONTROL—9041004-01				SAFETY CONTROL — 9041002-02			
COLD OUT	NORM OUT	NORM IN	WARM IN	COLD OUT	NORM OUT	NORM IN	WARM IN
13° ±2	36° ±1	42° ±1	47° ±2	25° ±2	30° ±1	38.5° ±1	43.5° ±2
ALTITUDE CORRECTION				ALTITUDE CORRECTION			
CW TURNS OF RANGE SCREW				CW TURNS OF RANGE SCREW			
Feet	Turns	Feet	Turns	Feet	Turns	Feet	Turns
2000	5/32	8000	27/32	2000	3/16	8000	1-1/16
4000	13/32	9000	31/32	4000	1/2	9000	13/16
6000	58	10000	1-1/16	6000	25/32	10000	1-5/16

After altitude correction has been completed, fine adjustment of the control can be accomplished by turning the screw driver slotted shaft (external).

To set the safety control the water supply to the float is stopped and the machine is allowed to run. When the water in the float and evaporator line has depleted the control should activate and the machine should stop. The water supply should then be turned on. After a period of ten minutes, the safety control will activate allowing the machine to run.

Bin control adjustment should be made to allow adequate bin fill without bin overflow or evaporator obstruction by packing ice.

**CAUTION:** Safety control setting must allow continuous water flow to evaporator.

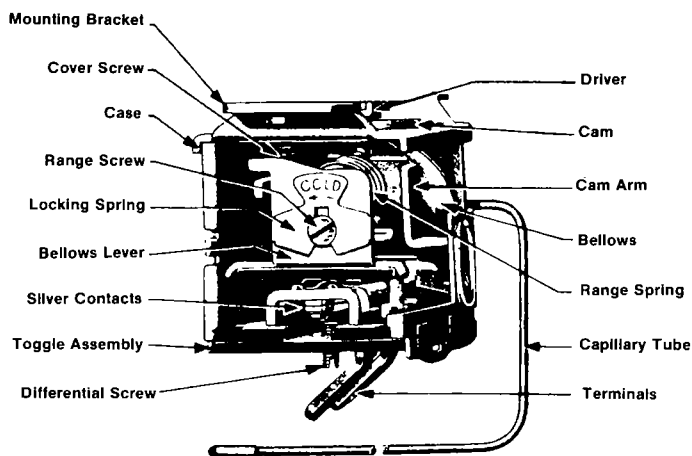

SECTION VIEW

Bin Control  
Part Number 9041004-01

Safety Control  
Part Number 9041002-02

Screw driver SLOTTED  
shaft for turning the  
cam



# GENERAL FLAKER SERVICE INFORMATION

## CONTINUED

### DISPENSE TIMER ADJUSTMENT

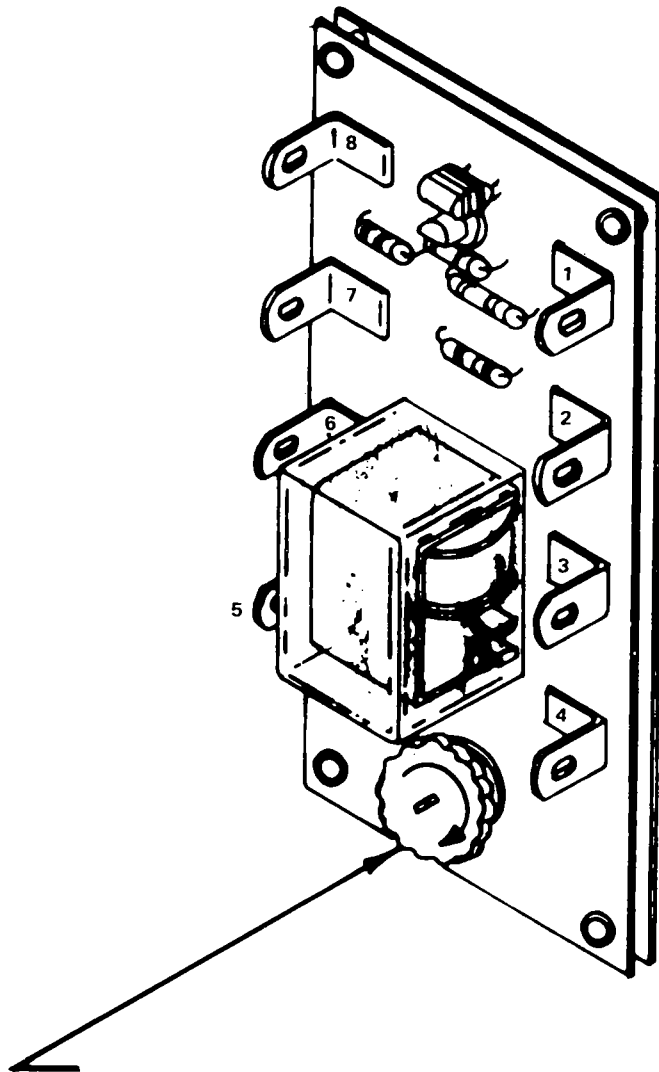

NOTE:

ADJUST CLOCKWISE TO INCREASE PORTION  
TIMER LOCATED INSIDE ELECTRICAL CONTROL BOX.

# GENERAL FLAKER SERVICE INFORMATION

## CONTINUED SERVICE DIAGNOSIS

CONDITION	POSSIBLE CAUSE
1) Motor compressor and auger motor won't run.	1) a. Check supply voltage. b. Check on-off switch. c. Check safety switch. d. Check for loose connections. e. Defective auger motor. f. Defective wiring harness.
2) Low ice production.	2) a. Check for obstructions in the flow of water to the evaporator; check float adjustment. b. Restricted filter-drier. c. Dirty condenser. d. Low line voltage. e. Condenser fan not working. f. Valves in compressor not functioning properly. g. System is under or over charged. h. Dirty auger. Clean per instructions. i. Water float valve plugged.
3) Unit runs but no ice production.	3) a. Water shut off. b. Water float valve plugged. c. Inlet water tube frozen at evaporator due to safety control being set too cold. d. Unit out of gas. e. Motor compressor not pumping.
4) Motor compressor and auger motor run but no ice production.	4) a. Filter-drier plugged. b. Inefficient compressor. c. Combination of no water to evaporator and a defective safety control. d. Refrigerant loss.
5) Auger motor runs but motor compressor doesn't.	5) a. Loose connection at compressor terminal block. b. Defective wiring harness. c. Defective overload-relay-starting capacitor or motor compressor. d. Low voltage — causing motor compressor to short cycle on overload e. Burned out motor compressor.

# GENERAL FLAKER SERVICE INFORMATION

## CONTINUED SERVICE DIAGNOSIS

CONDITION	POSSIBLE CAUSE
6) Vibration in water reservoir assembly.	6) a. Too high water pressure or defective water pressure regulator. b. Partially stopped up float valve.
7) Machine fails to shut off when bin is full.	7) a. Bin control switch defective or out of adjustment.
8) Machine is noisy.	8) a. Auger needs cleaning. b. Chain is slipping. c. Defective compressor. d. Loose components. e. Fan hitting shroud or condensor.
9) Compressor cuts out on overload.	9) a. Low line voltage. It should be within + 10%. b. High head pressure. c. Defective compressor unit, starting capacity relay or overload device. d. Loose electrical connection probably in compressor junction box.
10) Motor compressor runs but condensor does not.	10) a. Loose electrical connections. b. Fan blade cannot turn due to obstruction. c. Motor burned out.
11) Noisy motor compressor.	11) a. Defective compressor unit. b. High head pressure.
12) High head pressure.	12) a. Dirty condenser. b. System is overcharged. c. Air in refrigeration system. d. Defective fan motor.
13) Low suction pressure.	13) a. Restricted liquid flow through filter-drier. b. System is low on refrigerant. c. Moisture in refrigeration system. d. Water restriction to evaporator.
14) No voltage to auger motor or compressor junction box.	14) a. Check for voltage at on-off switch. b. An "open" in the bin control or the safety switch.
15) Condenser fan motor doesn't run.	15) a. Fan blade obstructed. b. Low voltage. c. Check for loose connections. d. Defective fan motor. e. Unit off on bin control.



# GENERAL FLAKER SERVICE INFORMATION

## CONTINUED

### SERVICE DIAGNOSIS

#### CONDITION

#### POSSIBLE CAUSE

- |                               |                                                                                                                                                                                                                      |
|-------------------------------|----------------------------------------------------------------------------------------------------------------------------------------------------------------------------------------------------------------------|
| 16) Auger motor doesn't work. | 16) a. Motor is out on overload.<br>b. Defective motor or gear box.<br>c. Low line voltage.                                                                                                                          |
| 17) Ice will not dispense.    | 17) a. Lid not on bin to actuate safety interlock.<br>b. Low line voltage.<br>c. Defective starting relay.<br>d. Defective motor.<br>e. Bin empty.<br>f. Defective dispense switch.<br>g. Auger not locked on drive. |

# PARTS SECTION

**When Ordering Parts  
 Please Specify  
 Model and Serial Number**

MILE HIGH EQUIPMENT COMPANY DENVER, COLORADO 80239 U.S.A.

MODEL \_\_\_\_\_ SERIAL NUMBER \_\_\_\_\_

VOLTS \_\_\_\_\_ Hz. \_\_\_\_\_ Ph. \_\_\_\_\_ WIRE \_\_\_\_\_

COMPRESSOR..... F.L.A. \_\_\_\_\_ L.R.A. \_\_\_\_\_

AUGER DRIVE MOTOR ..... Amps

BIN DISPENSE MOTOR ..... Amps

HARVEST MOTOR(S) EA. ( ) ..... Amps

FAN MOTOR(S) EA. ( ) ..... Amps

PUMP MOTOR(S) EA. ( ) ..... Amps

MINIMUM CIRCUIT AMPACITY ..... Amps

MAX. BRANCH CIRCUIT FUSE SIZE ..... Amps

REFRIGERANT TYPE \_\_\_\_\_

TOTAL SYSTEM REFRIGERANT CHARGE ..... Oz. \_\_\_\_\_ Grams

TEST PRESSURES			
R-12		R-502	
P.S.I.	BARS	P.S.I.	BARS
HI 245	HI 16.2	HI 325	HI 22.4
LO 145	LO 10.0	LO 175	LO 12.1



# PARTS SECTION

## COMPRESSOR COMPONENTS

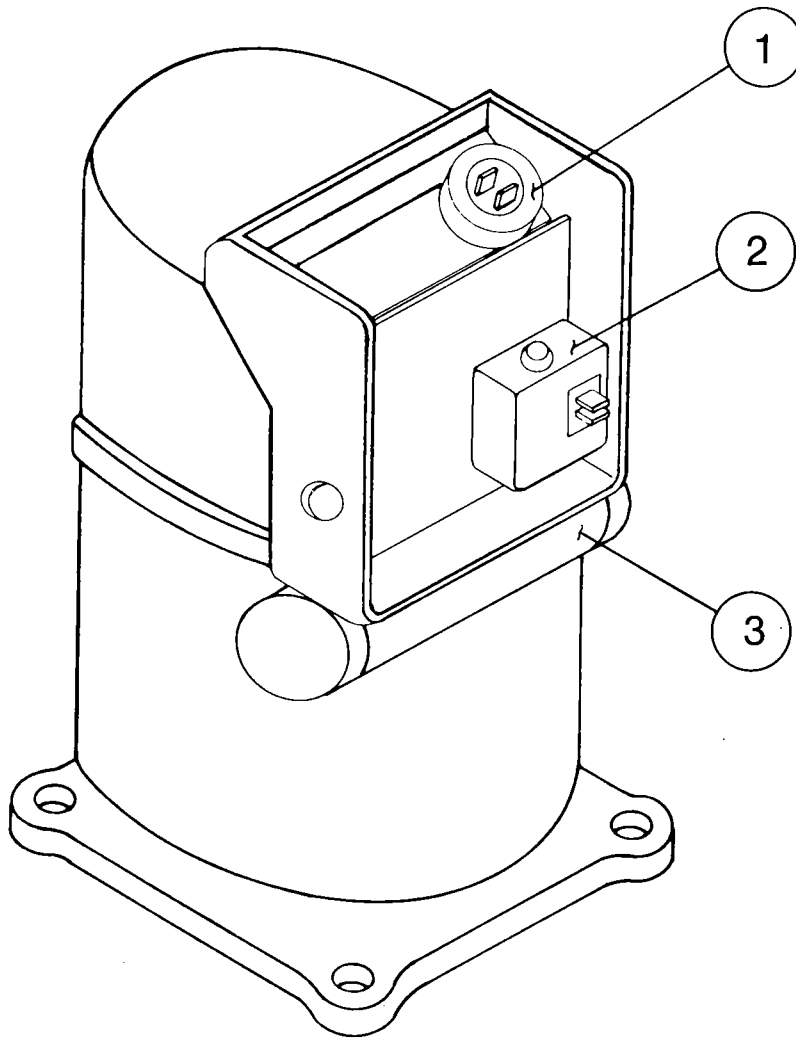

1. OVERLOAD
2. START RELAY
3. START CAPACITOR

Index Number	Description	No. Reqd.	Part Number
1	Overload Protector	1	9181005-01
2	Start Relay	1	9181004-01
3	Start Capacitor	1	9181003-01

# PARTS SECTION

## CABINET PARTS

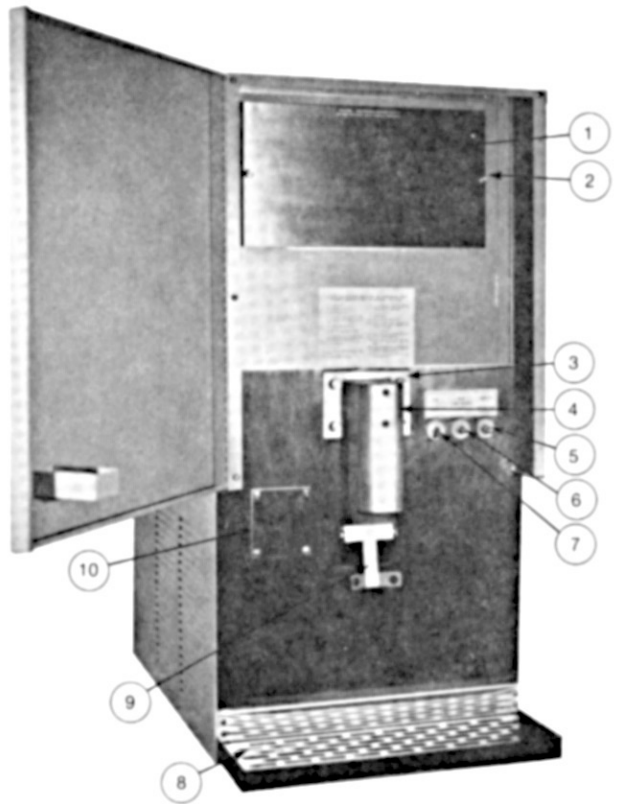
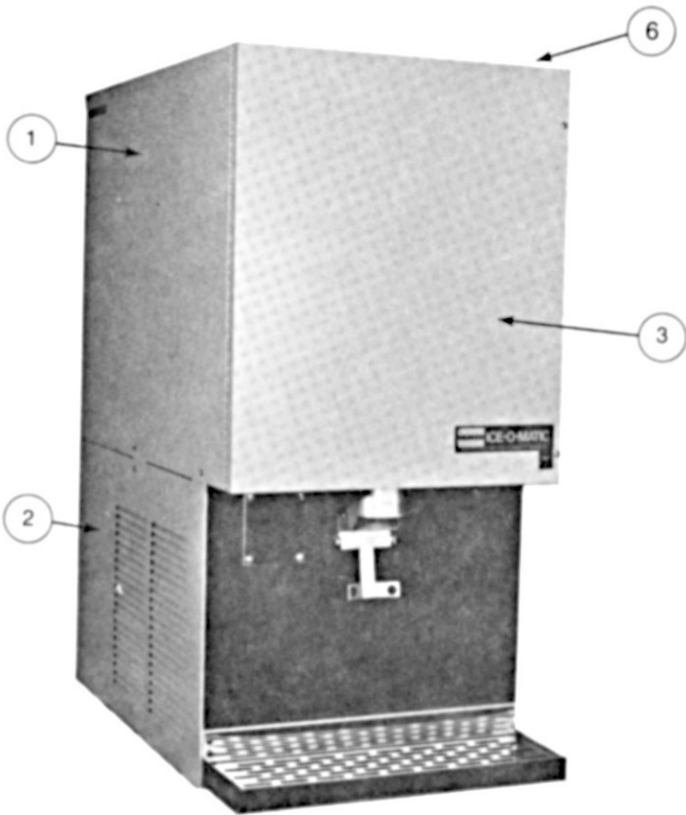

# PARTS SECTION

## CABINET PARTS

### TOP PICTURE

<b>Index Number</b>	<b>Description</b>	<b>No. Reqd.</b>	<b>Part Number</b>	<b>Remarks</b>
1	Top Left Hand Panel	1	2031274-01	
2	Bottom Left Hand Panel	1	3021328-01	
3	Front Hinged Panel	1	2031112-02	
4	Bottom Right Hand Panel	1	3021327-01	Not Shown
5	Top Right Hand Panel	1	3021329-01	Not Shown
6	Top Panel	1	3021196-01	
7	Top Back Panel	1	3021195-01	Not Shown
8	Bottom Back Panel	1	3021197-01	Not Shown

### BOTTOM PICTURE

1	Bin Door	1	2031113-01	
2	Thumb Screws	2	9031051-01	
3	Thumb Screw	4	9031051-02	
4	Dispense Chute	1	2031119-01	
5	Safety Interlock Switch	1	9101056-02	
6	Portion Control Switch	1	9101035-01	
7	On/Off Switch	1	9101021-01	
8	Grate	1	2031114-01	
9	Dispense Lever	1	2021126-01	
10	Cover Plate	1	3011282-01	

# PARTS SECTION

## DISPENSE SYSTEM

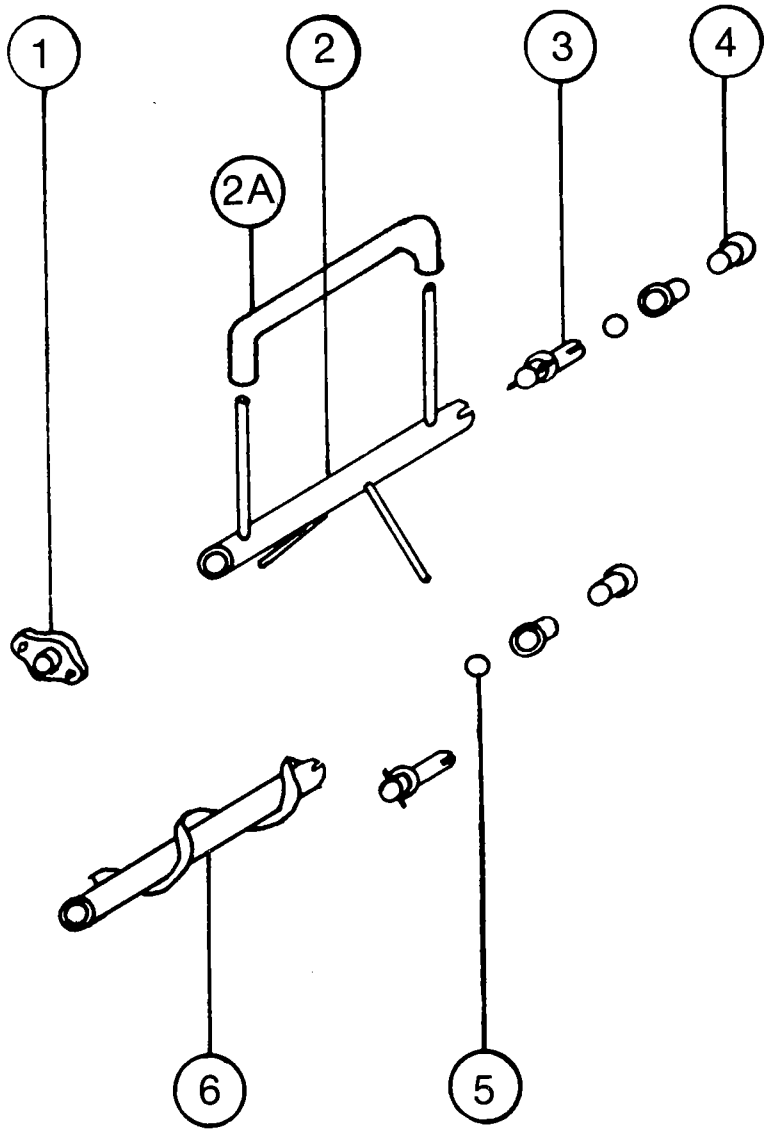

# PARTS SECTION

## DISPENSE SYSTEM

Index Number	Description	No. Reqd.	Part Number	Remarks
1	Bearing	1	9121028-01	
2	Agitator	1	2071003-01	
2A	Wiper Blade	1	No Part Number	3/8 thin wall tubing 22" long
3	Drive Shaft	1	2051019-01	
4	Nylotron Bushing	2	9121019-01	
5	0" Ring	2	9131009-09	
6	Dispense Auger	1	2071004-01	

# PARTS SECTION

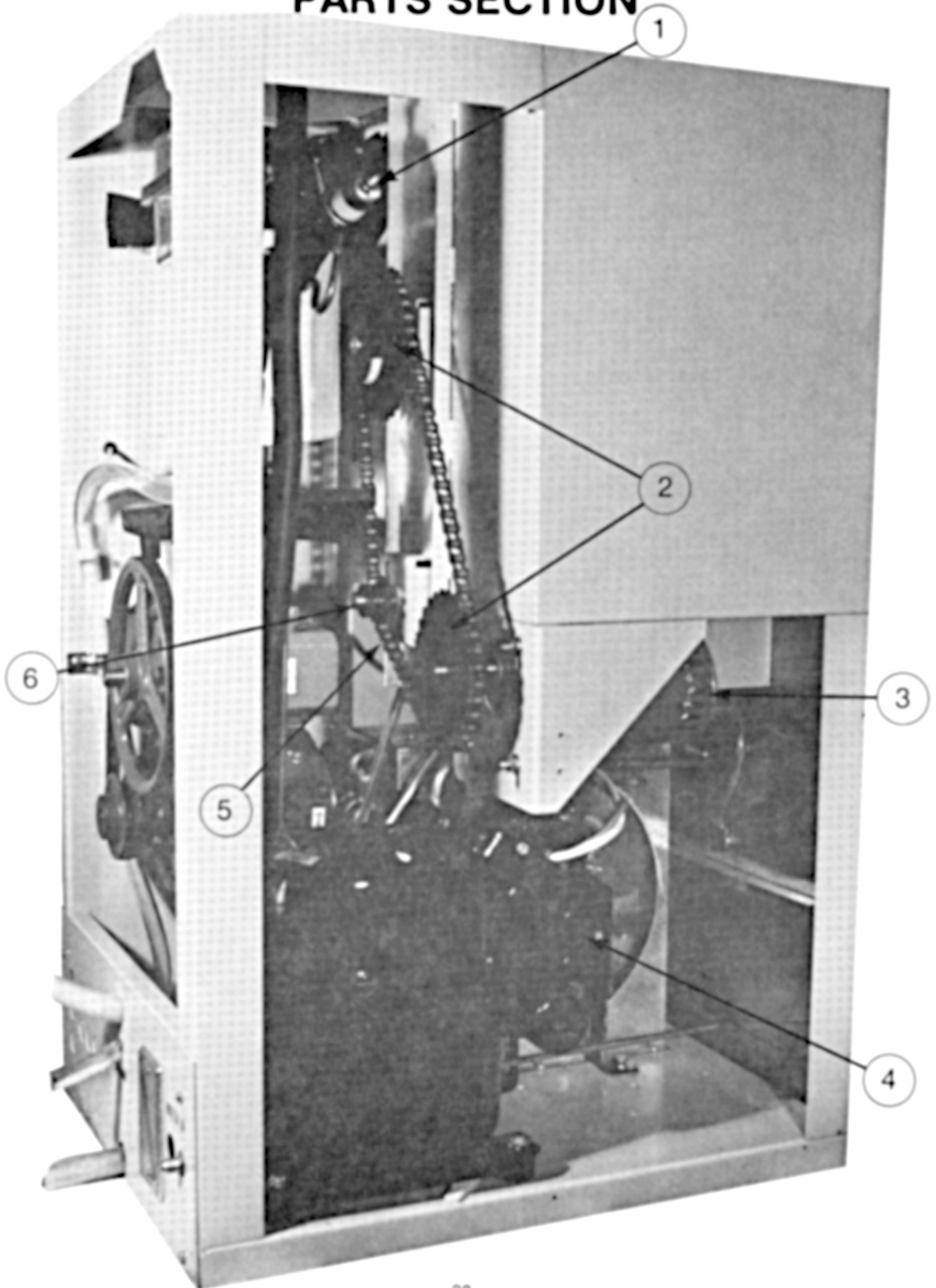



# PARTS SECTION

Index Number	Description	No. Reqd.	Part Number	Remarks
1	Expansion Valve	1	9151005-01	
2	Sprocket	2	9111007-04	
3	Dispense Motor	1	9161072-01	Franklin
3A	Dispense Motor	1	9161049-01	GE/Amtech
4	Air Condenser	1	9141002-02	
4A	Fan Motor	1	9161004-01	Not Shown
4B	Fan Blade	1	9131017-01	Not Shown
4C	Cond. Shroud			Not Shown
5	Chain	1	6101001-01	
6	Idler Sprocket	1	9111007-02	

# PARTS SECTION

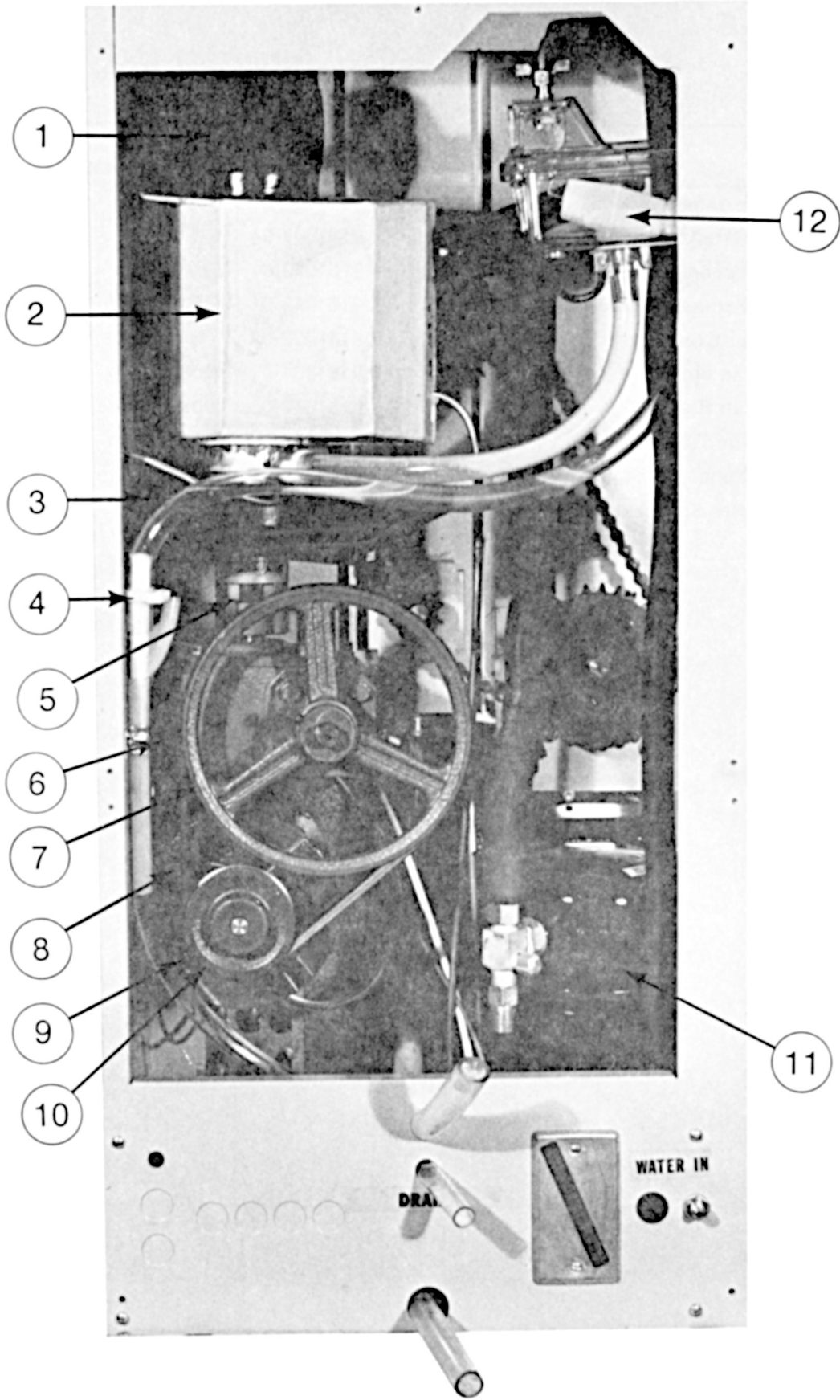

# PARTS SECTION

## CHASSIS ASSEMBLY

Index Number	Description	No. Reqd.	Part Number	Remarks
1	Legioneer Cap	1	2101004-01	Not Shown
2	Evaporator Assy.	1	2051042-01	See page 36 & 37
3	Drip Boot	1	9051007-01	
4	Y-Drain	1	9051009-01	
5	Coupler	1	9111016-01	
6	Gear Box	1	9171002-01	
7	Gear Box Puley	1	9111002-08	
8	V Belt	1	9111001-01	
9	Auger Motor	1	9161008-01	
10	Drive Pulley	1	9111002-03	
11	Compressor	1	9181001-91	
12	Float Assy. Complete	1	9131032-01	
	Float Ball & Stem Only	1	9131032-92	Not Shown
	Ice Chute	1	2021111-01	Not Shown
	Evaporator Gasket (White)	1	9051011-01	Not Shown
	Bin Gasket (Black)	1	9051004-01	Not Shown
	Receiver Drier	1	9151033-01	Not Shown

# PARTS SECTION

## ELECTRICAL SYSTEM

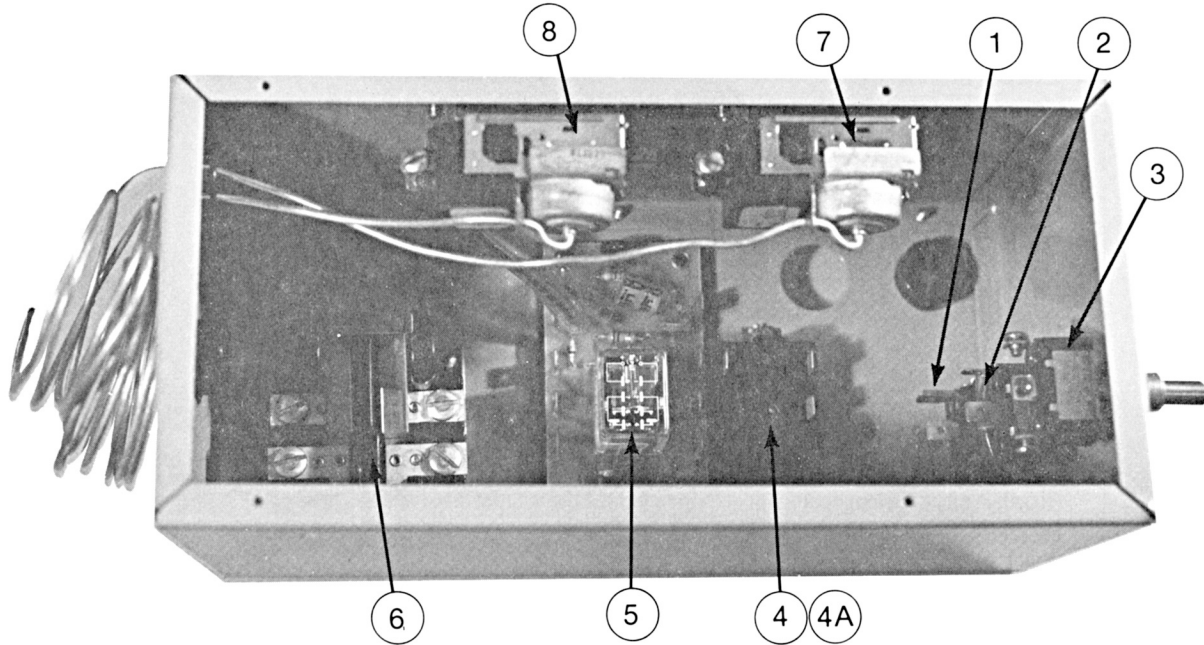

Index Number	Description	No. Reqd.	Part Number	Remarks
1	On/Off Switch	1	9101021-01	
2	Portion Control Switch	1	9101035-01	
3	Safety Interlock Switch	1	9101056-02	
4	Relay	1	9101104-01	Franklin Gear Motor Only
4A	Relay	1	9101049-01	GE/Amtech Gear Motor Only
5	Timer	1	9101052-01	
6	Contactor	1	9101018-01	
7	Safety Control	1	9041002-02	
8	Bin Control	1	9041004-01	

# PARTS SECTION

## WATER COOLED CONDENSING UNIT COMPONENTS

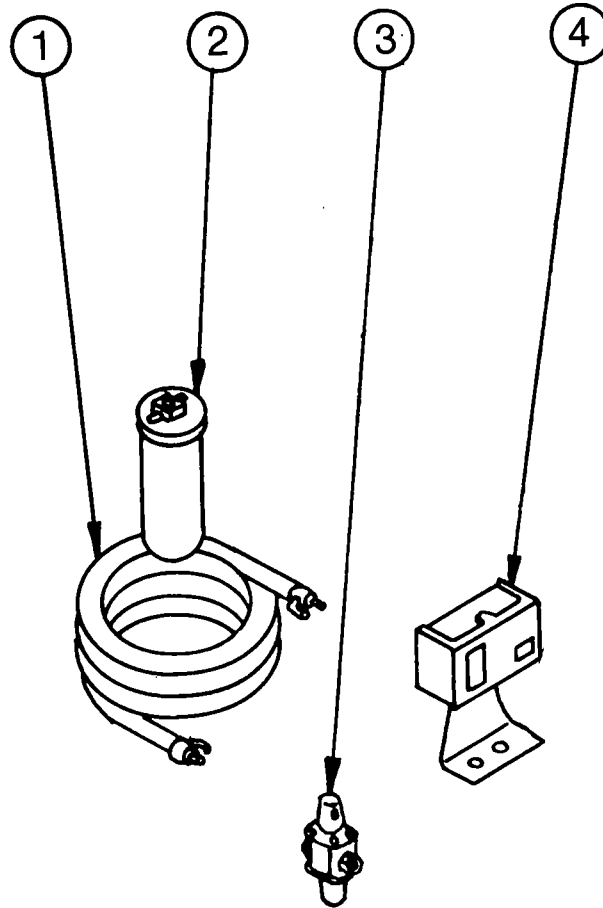

Index Number	Description	No. Reqd.	Part Number	Remarks
1	Water Cooled Condenser	1	9141002-01	
2	Receiver/Drier	1	9151033-01	
3	Water Valve	1	9041010-01	
4	High Pressure Safety Control	1	9041006-01	
SALT WATER UNITS (ONLY)				
1	Salt Water Condenser	1	9141022-01	
3	Salt Water Valve	1	9041010-02	

# PARTS SECTION

## EVAPORATOR ASSEMBLY

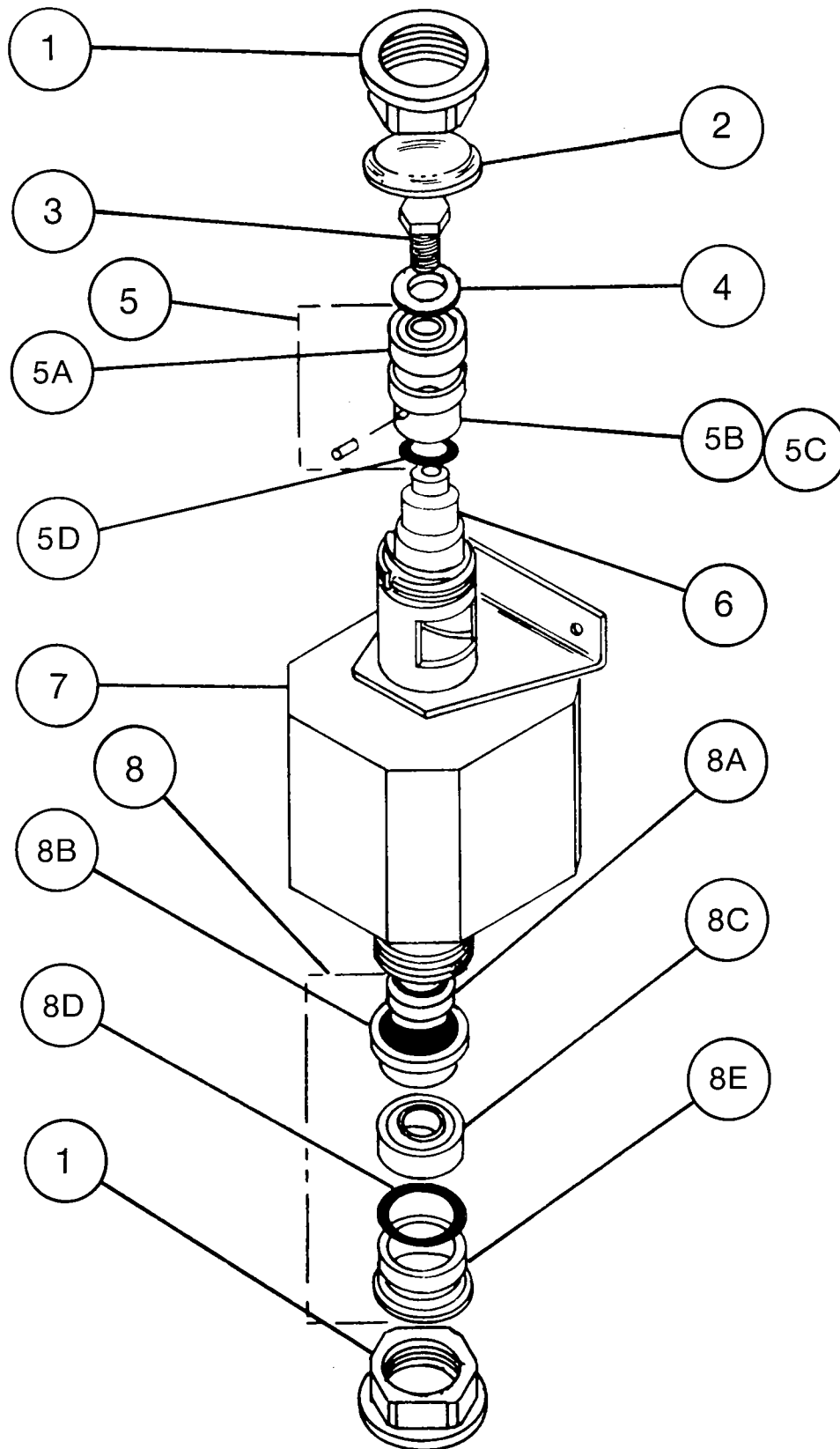

# PARTS SECTION

## EVAPORATOR ASSEMBLY

Index Number	Description	No. Reqd.	Part Number	Remarks
1	Evaporator Nut	2	3041006-01	Upper & Lower
2	Evaporator Cap	1	3011011-01	
3	Bolt	1	9031001-01	
4	Washer	1	9031004-09	
5	Upper Housing Assy.	1	2051030-01	Includes 5A-D
5A	Upper Bearing	1	9121001-02	
5B	Upper Bearing Housing	1	3041018-01	
5C	Locating Pin	1	9131010-01	
5D	"O" Ring - Upper	1	9131009-03	
6	Auger	1	9131012-01	
7	Evaporator Barrel	1	2051025-01	
8	Lower Housing Assy.	1	2051008-01	Includes 8A-E
8A	Seal Face	1	9121026-01	8A & 8B sold in
8B	Seal Bellows	1	(Set)	matched set only.
8C	Lower Bearing	1	9121001-03	
8D	"O" Ring - Lower	1	9131009-08	
8E	Lower Bearing Housing	1	3041007-01	
	Evaporator Assy.	1	2051042-01	Includes all of the above.

## Free Manuals Download Website

<http://myh66.com>

<http://usermanuals.us>

<http://www.somanuals.com>

<http://www.4manuals.cc>

<http://www.manual-lib.com>

<http://www.404manual.com>

<http://www.luxmanual.com>

<http://aubethermostatmanual.com>

Golf course search by state

<http://golfingnear.com>

Email search by domain

<http://emailbydomain.com>

Auto manuals search

<http://auto.somanuals.com>

TV manuals search

<http://tv.somanuals.com>