

**NOTE:**  
Please read all  
instructions carefully  
before using this product

Table of Contents

Safety Notice

Hardware Pack

Assembly Instruction

Exploded Diagram

Parts List

Warranty

Ordering Parts

Model  
IGS 8858

Retain This  
Manual for  
Reference

07/25/06

**OWNER'S  
MANUAL**

# IMPEX

## IRON GRIP STRENGTH WEIGHT BENCH IGS-8858

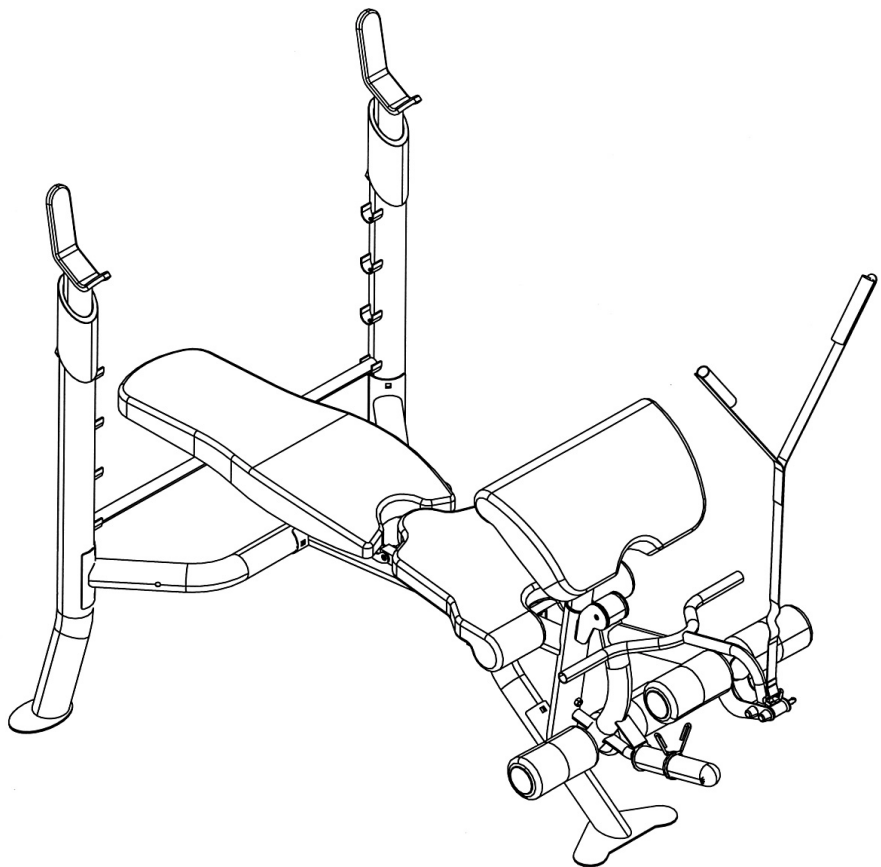

**IMPEX® INC.**

14777 Don Julian Rd., City of Industry, CA 91746

Tel: (800) 999-8899 Fax (626) 961-9966

[www.impex-fitness.com](http://www.impex-fitness.com)

[info@impex-fitness.com](mailto:info@impex-fitness.com)

---

## TABLE OF CONTENTS

BEFORE YOU BEGIN.....	1
IMPORTANT SAFETY NOTICE.....	2
HARDWARE PACK.....	4
ASSEMBLY INSTRUCTIONS.....	6
EXPLODED DIAGRAM.....	11
PARTS LIST.....	12
WARRANTY.....	13
ORDERING PARTS.....	13

---

## BEFORE YOU BEGIN

Thank you for selecting the **IRON GRIP STRENGTH IGS-8858 BENCH** by **IMPEX® INC.** For your safety and benefit, read this manual carefully before using the machine. As a manufacturer, we are committed to provide you complete customer satisfaction. If you have any questions, or find there are missing or damaged parts, we guarantee you complete satisfaction through direct assistance from our factory. To avoid unnecessary delays, *please call our TOLL-FREE customer service number.* Our Customer Service Agents will provide immediate assistance to you.

Toll-Free Customer Service Number

1-800-999-8899

Mon. - Fri. 9 a.m. - 5 p.m. PST

[www.impex-fitness.com](http://www.impex-fitness.com)

[info@impex-fitness.com](mailto:info@impex-fitness.com)

## IMPORTANT SAFETY NOTICE

### PRECAUTIONS

**This exercise machine is built for optimum safety. However, certain precautions apply whenever you operate a piece of exercise equipment. Be sure to read the entire manual before you assemble or operate your machine. In particular, note the following safety precautions:**

1. Keep children and pets away from the machine at all times. DO NOT leave children unattended in the same room with the machine.
2. Only one person at a time should use the machine.
3. If the user experiences dizziness, nausea, chest pain, or any other abnormal symptoms, STOP the workout at once. CONSULT A PHYSICIAN IMMEDIATELY.
4. Position the machine on a clear, leveled surface. DO NOT use the machine near water or outdoors.
5. Keep hands away from all moving parts.
6. Always wear appropriate workout clothing when exercising. DO NOT wear robes or other clothing that could become caught in the machine. Running or aerobic shoes are also required when using the machine.
7. Use the machine only for its intended use as described in this manual. DO NOT use attachments not recommended by the manufacturer.
8. Do not place any sharp object around the machine.
9. Disabled person should not use the machine without a qualified person or physician in attendance.
10. Before using the machine to exercise, always do stretching exercises to properly warm up.
11. Never operate the machine if the machine is not functioning properly.
12. A spotter is recommended during exercise.
13. Maximum user's weight: 300 lbs.
14. Maximum weight on uprights: 600 lbs.
15. Maximum weight on leg developer: 100 lbs.

### CARE AND MAINTENANCE

1. Inspect and tighten all parts before using the machine.
2. The machine can be cleaned using a damp cloth and mild non-abrasive detergent. DO NOT use solvents.

**WARNING: BEFORE BEGINNING ANY EXERCISE PROGRAM, CONSULT YOUR PHYSICIAN. THIS IS ESPECIALLY IMPORTANT FOR INDIVIDUALS OVER THE AGE OF 35 OR PERSONS WITH PRE-EXISTING HEALTH PROBLEMS. READ ALL INSTRUCTIONS BEFORE USING ANY FITNESS EQUIPMENT. IMPEX INC. ASSUMES NO RESPONSIBILITY FOR PERSONAL INJURY OR PROPERTY DAMAGE SUSTAINED BY OR THROUGH THE USE OF THIS PRODUCT.**

**SAVE THESE INSTRUCTIONS.**

# WARNING LABEL REPLACEMENT

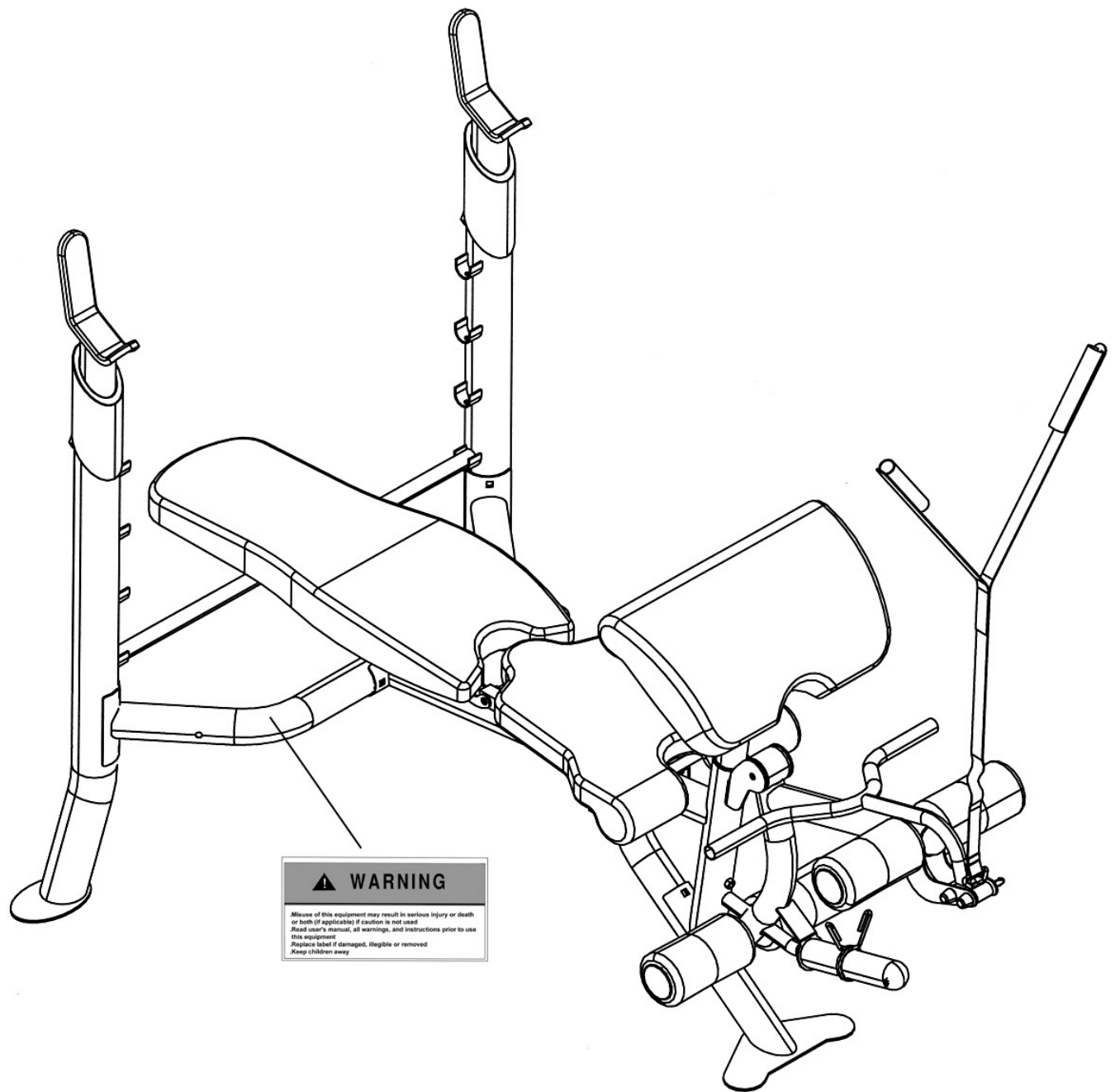

**The Warning Label shown here has been placed on the Cross Brace. If the label is missing or illegible, please call customer service at 1-800-999-8899 for replacement. Apply the label in location shown**

# HARDWARE PACK

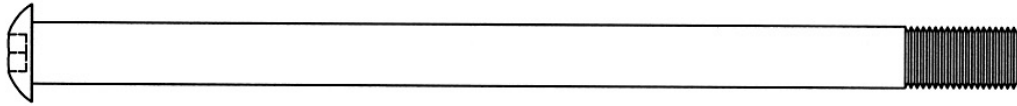

#42 M12 x 7 5/8" Allen Bolt (Qty 1)

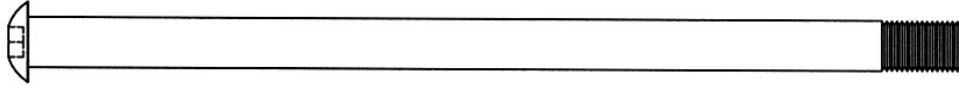

#43 M12 x 7 1/4" Allen Bolt (Qty 1)

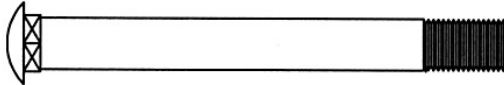

#40 M10 x 3 3/4" Carriage Bolt (Qty 4)

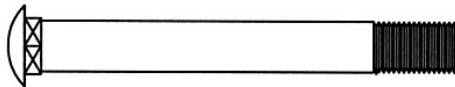

#58 M10 x 3 3/8" Carriage Bolt (Qty 2)

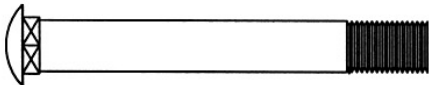

#41 M10 x 3 1/8" Carriage Bolt (Qty 6)

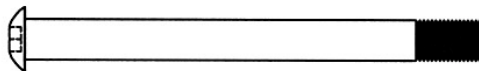

#56 M8 x 3 1/2" Allen Bolt (Qty 1)

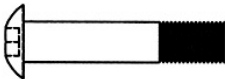

#45 M8 x 1 5/8" Allen Bolt (Qty 8)

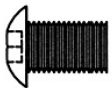

#44 M10 x 5/8" Allen Bolt (Qty 2)



#46 M8 x 5/8" Allen Bolt (Qty 2)

mm

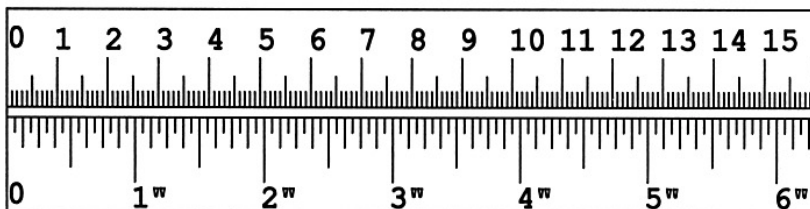

# HARDWARE PACK

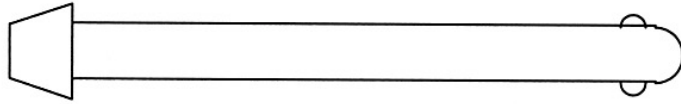

#54 4" Lock Pin (Qty 1)

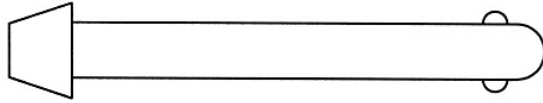

#28 3" Lock Pin (Qty 2)



#26 Axle (Qty 1)

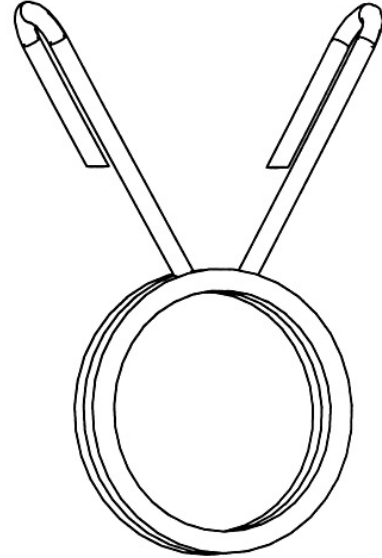

#25 Spring Clip (Qty 1)

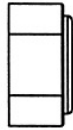

#51 M12 Aircraft Nut (Qty 1)



#52 M10 Aircraft Nut (Qty 13)



#57 M8 Aircraft Nut (Qty 1)



#50 Ø 5/8" Washer (Qty 12)

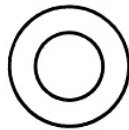

#48 Ø 1" Washer (Qty 2)

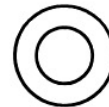

#49 Ø 3/4" Washer (Qty 16)

mm

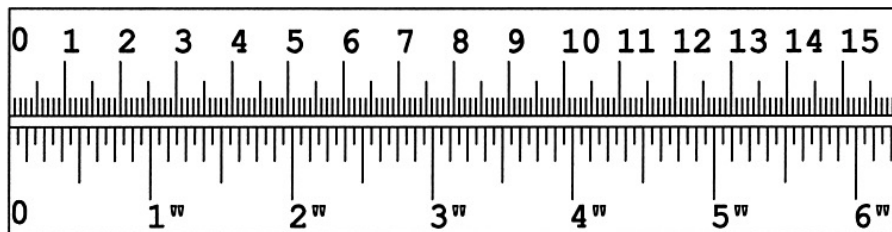

# ASSEMBLY INSTRUCTION

**Tools Required Assembling the Machine: Two Adjustable Wrenches and Allen Wrenches. NOTE: It is strongly recommended two or more people assembling this machine to avoid possible injury.**

## STEP 1 (See Diagram 1)

- A.) Connect the Left & Right Upright Beam (# 1 & #2) by a Cross Brace (#4) in the mid span. Secure them with M10 x 3 3/4" Carriage Bolts (#40), one 5 1/2" Bent Bracket (#16), two Ø 3/4" Washers (#49), and two M10 Aircraft Nuts (#52) on each side.
- B.) Insert two Crutches (#6) into the top openings on the top of Left & Right Upright Beams. Insert two M18 Lock Knobs (#31) through selected holes to obtain desired height.
- C.) Place the Backrest Adjustment Bar (#5) on the selected slot on the Upright Beams to obtain the desired backrest incline.

**DIAGRAM 1**

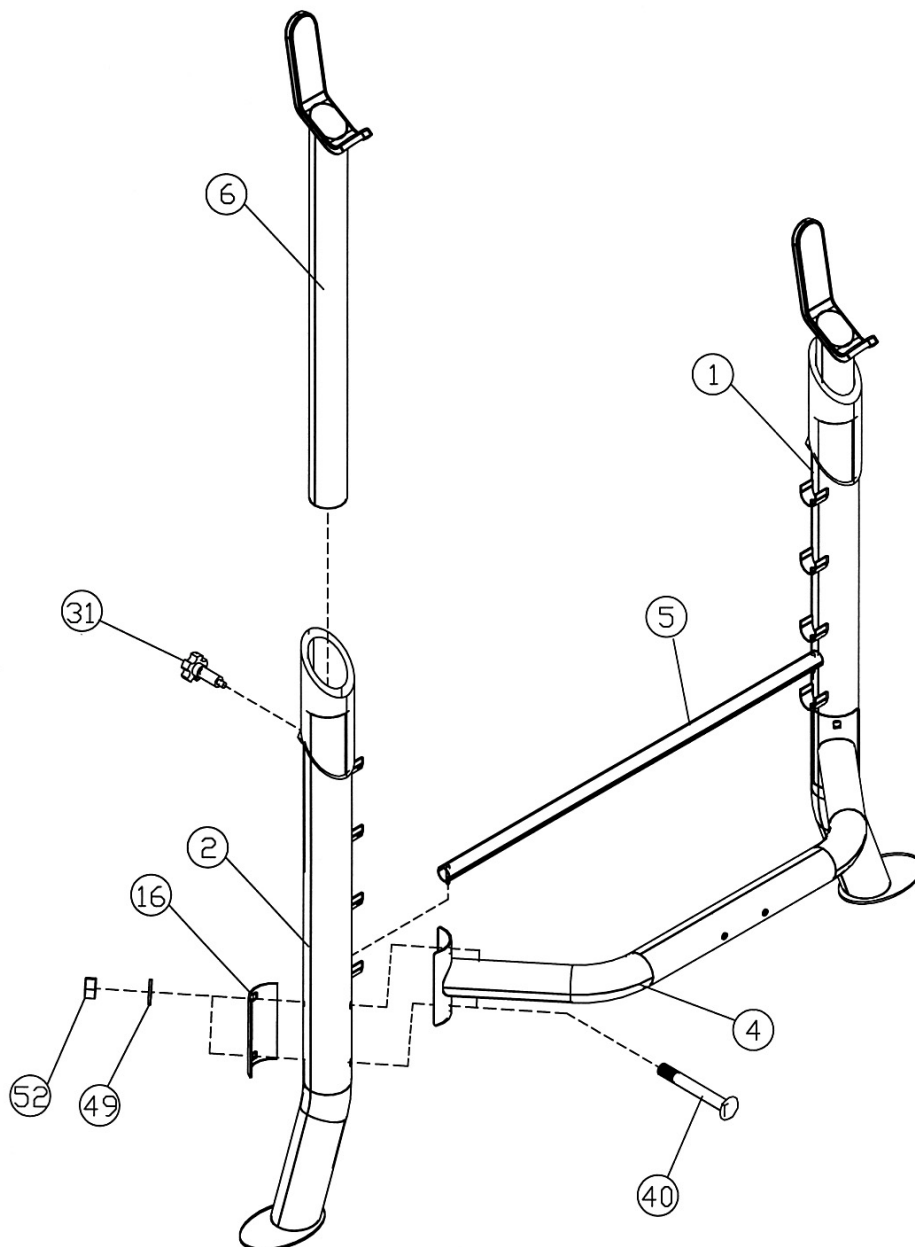

## STEP 2 (See Diagram 2)

- A.) Attach the front of Main Seat Support (#3) to the Front Post (#9). Secure it with two M10 x 3 1/8" Carriage Bolts (#41), one 6 1/4" Bent Bracket (#18), two Ø 3/4" Washers (#49), and two M10 Aircraft Nuts (#52).
- B.) Attach the Main Seat Support to the top of Front Post. Secure it with two M10 x 3 1/8" Carriage Bolts (#41), one 4 3/4" Bent Bracket (#17), two Ø 3/4" Washers (#49), and two M10 Aircraft Nuts (#52).
- C.) Attach the Main Seat Support to the Cross Brace (#4). Secure it with two M10 x 3 1/8" Carriage Bolts (#41), two Ø 3/4" Washers (#49), and two M10 Aircraft Nuts (#52) from top. Secure it with two M10 x 3 3/8" Carriage Bolts (#58), one 4 3/4" Bent Bracket (#17), two Ø 3/4" Washers (#49), and two M10 Aircraft Nuts (#52) from the side.

### DIAGRAM 2

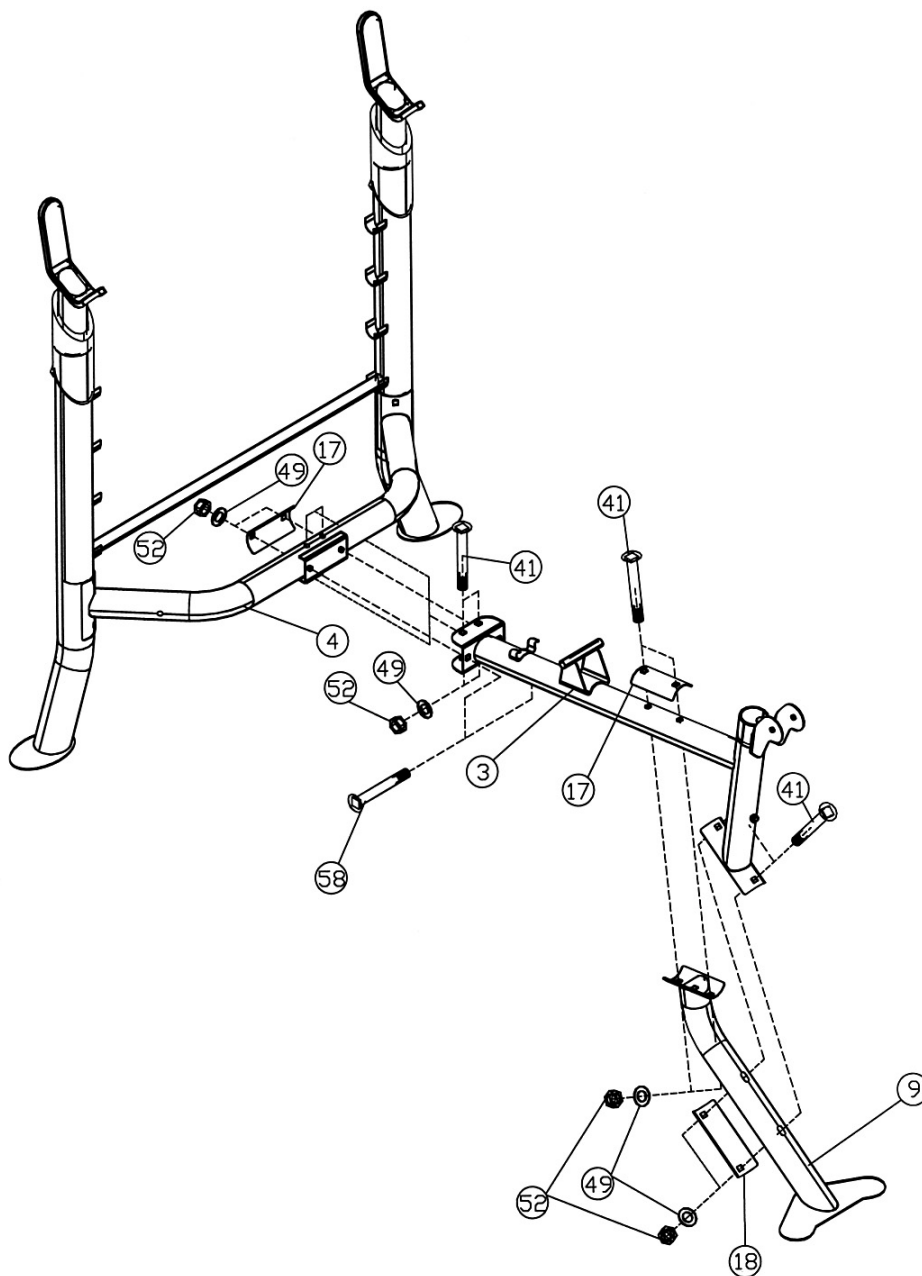



### STEP 3 (See Diagram 3)

- A.) Attach the Backrest Incline Support (#13) to the side-holes on the two Backrest Supports (#12). Align the holes. Secure it with one M12 x 7 1/4" Allen Bolt (#43), two Ø 3/4" Washers (#49), and one M12 Aircraft Nut (#52).
- B.) Attach the holes on the end of the Backrest Supports (#12) to the pivot on the Main Seat Support (#3). Attach the two ends of the Seat Support (#11) to the two holes on end of Backrest Supports. Align the holes. Secure them together with one M12 x 7 5/8" Allen Bolt (#42), two Ø 1" Washers (#48), and one M12 Aircraft Nut (#51).
- C.) Do not over tighten the Nuts and Bolts. Make sure the Backrest Supports and Backrest Incline are able to swivel.
- D.) Place the other ends of Seat Support onto the Main Seat Support. Use a 4" Lock Pin (#54) through the hole on Seat Support under the Main Seat Support to secure the incline of the Seat.
- E.) Insert the Arm Curl Stand (#7) into the opening on Main Seat Support. Use a M10 Lock Knob (#32) to lock the Stand at desired height.

**DIAGRAM 3**

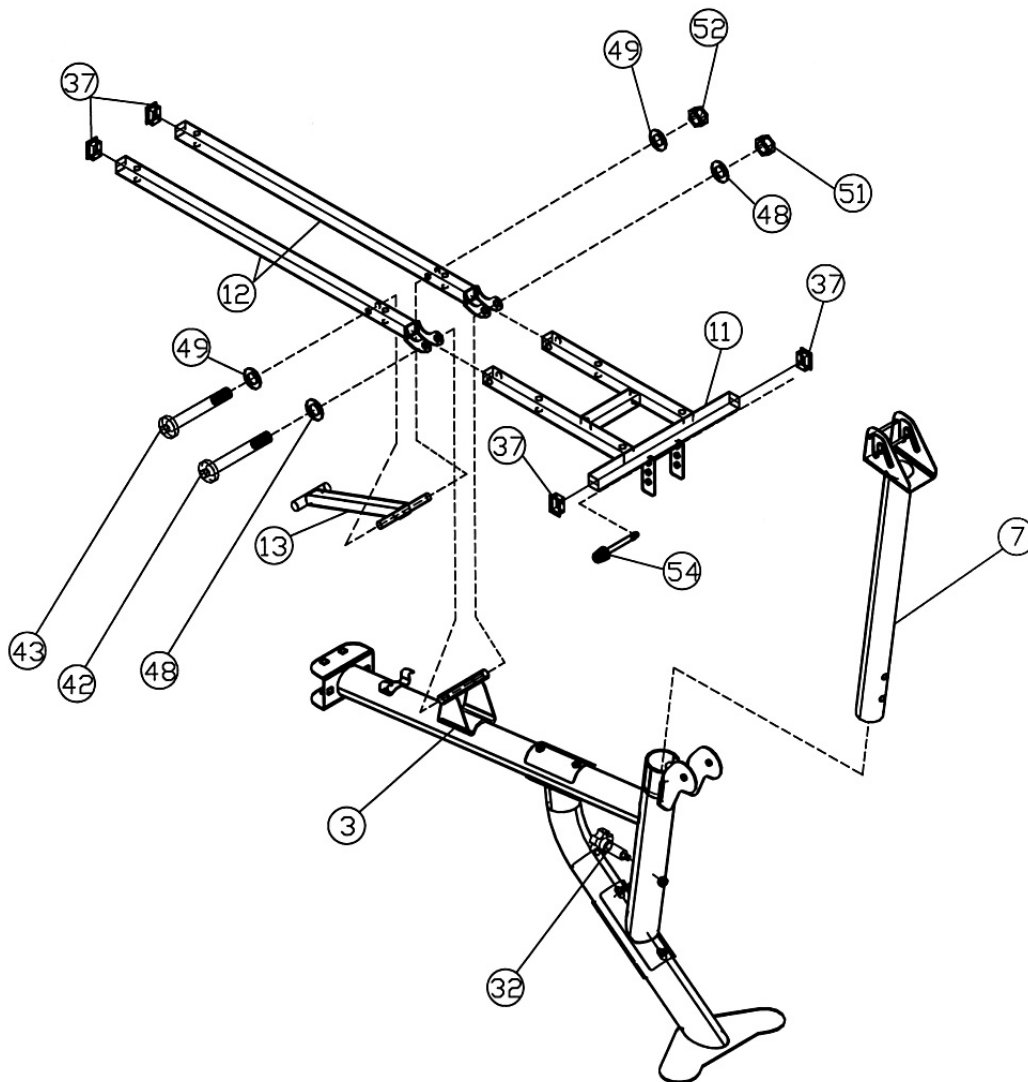

## STEP 4 (See Diagram 4)

- A.) Attach the Backrest Board (#20) to the Backrest Supports (#12). Secure it with four M8 x 1 5/8" Allen Bolts (#45) and four Ø 5/8" Washers (#50).
- B.) Place the Seat (#21) onto the Seat Support (#11). Secure it with four M8 x 1 5/8" Allen Bolts (#45) and four Ø 5/8" Washers (#50).
- C.) Attach the Arm Curl Pad (#22) to the Arm Curl Bracket (#55). Secure it with two M8 x 5/8" Allen Bolts (#46) and two Ø 5/8" Washers (#50).
- D.) Attach the Arm Curl Bracket to the bracket on the Arm Curl Stand (#7). Insert the M8 x 3 1/2" Allen Bolt (#56) through the open track on the Arm Curl Stand and the holes on the Arm Curl Bracket. Secure the Bolt with two Ø 5/8" Washers (#50) and one M8 Aircraft Nut (#57). Do not over tighten the Nut and Bolt. The Bolt needs to be able to slide on the track freely.

**DIAGRAM 4**

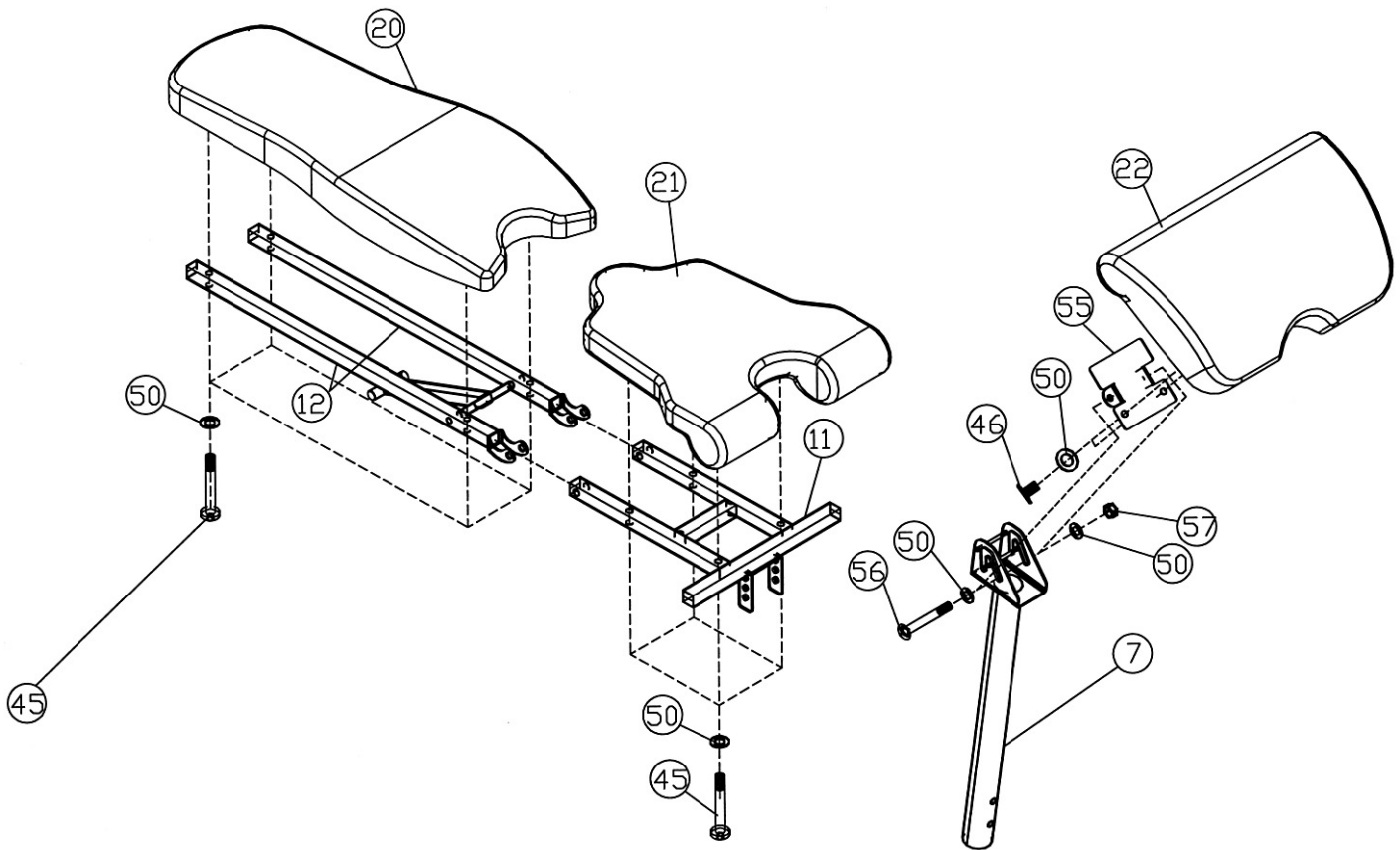

## STEP 5 (See Diagram 5)

- A.) Attach the Leg Developer (#8) to the Main Seat Support. Secure it with an Axle (#26), two M10 x 5/8" Allen Bolts (#44), and two Ø 3/4" Washers (#49).
- B.) Insert two Foam Tubes (#19) halfway through the holes on the Leg Developer. Push four Foam Rolls (#29) onto the Tubes from both ends. Plug four Foam Roll End Caps (#33) into the ends.
- C.) Slide an Olympic Sleeve (#30) onto the weight post on Leg Developer. Attach a Spring Clip (#25) onto the Sleeve.
- D.) Attach the Arm Curl Handle to the back hole on the Leg Developer. Secure it with one 3" Lock Pin (#28). Attach the Abdominal Strap (#53) to the front hole on Leg Developer. Secure it with one 3" Lock Pin (#28).
- E.) Pull up and flip the Arm Curl Pad along the track to face the back when doing Abdominal exercises using the Abdominal Strap.
- F.) Remove the Arm Curl Stand, Arm Curl Hand, and Abdominal Strap when doing Leg Developer exercises.

**DIAGRAM 5**

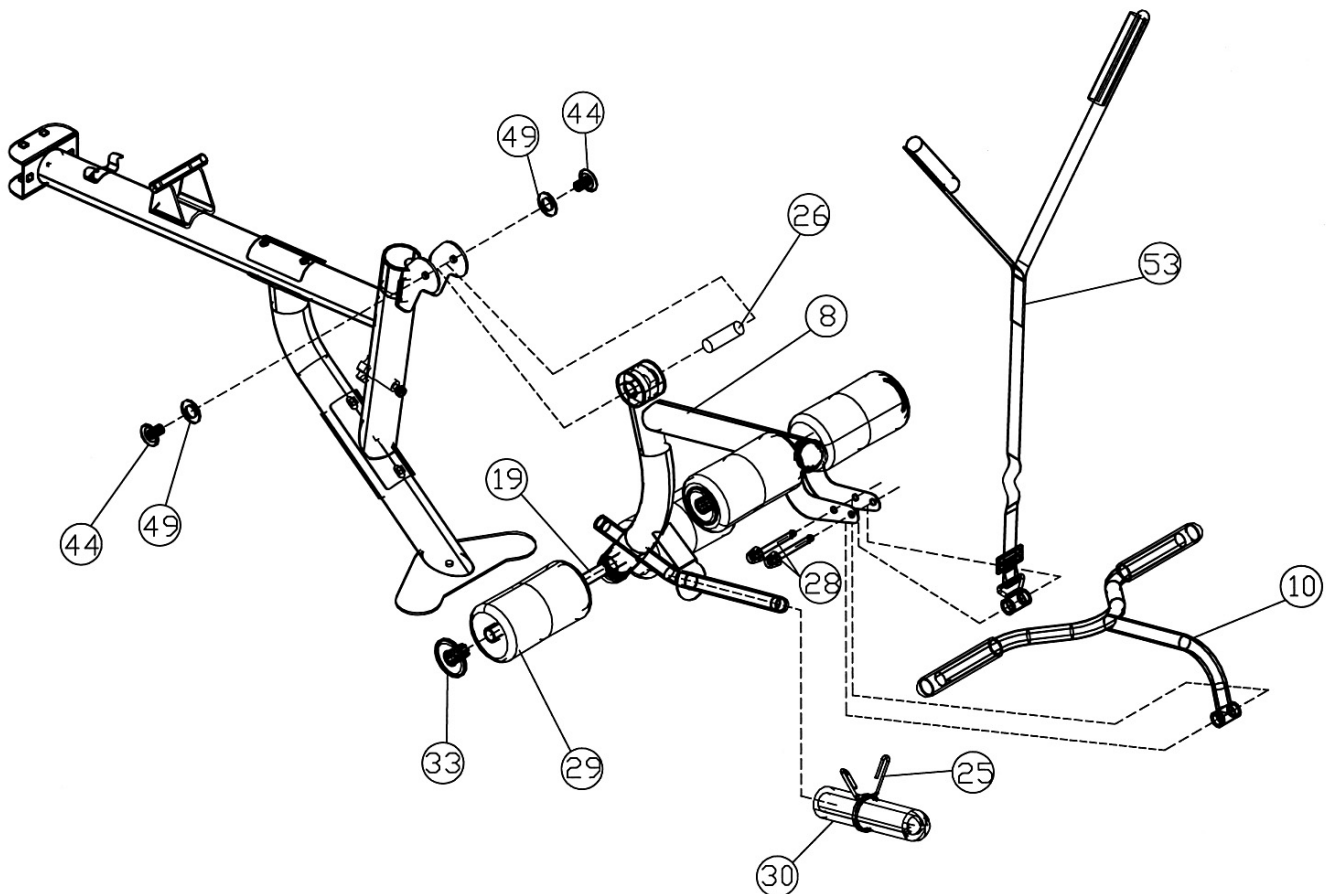

# EXPLODED DIAGRAM

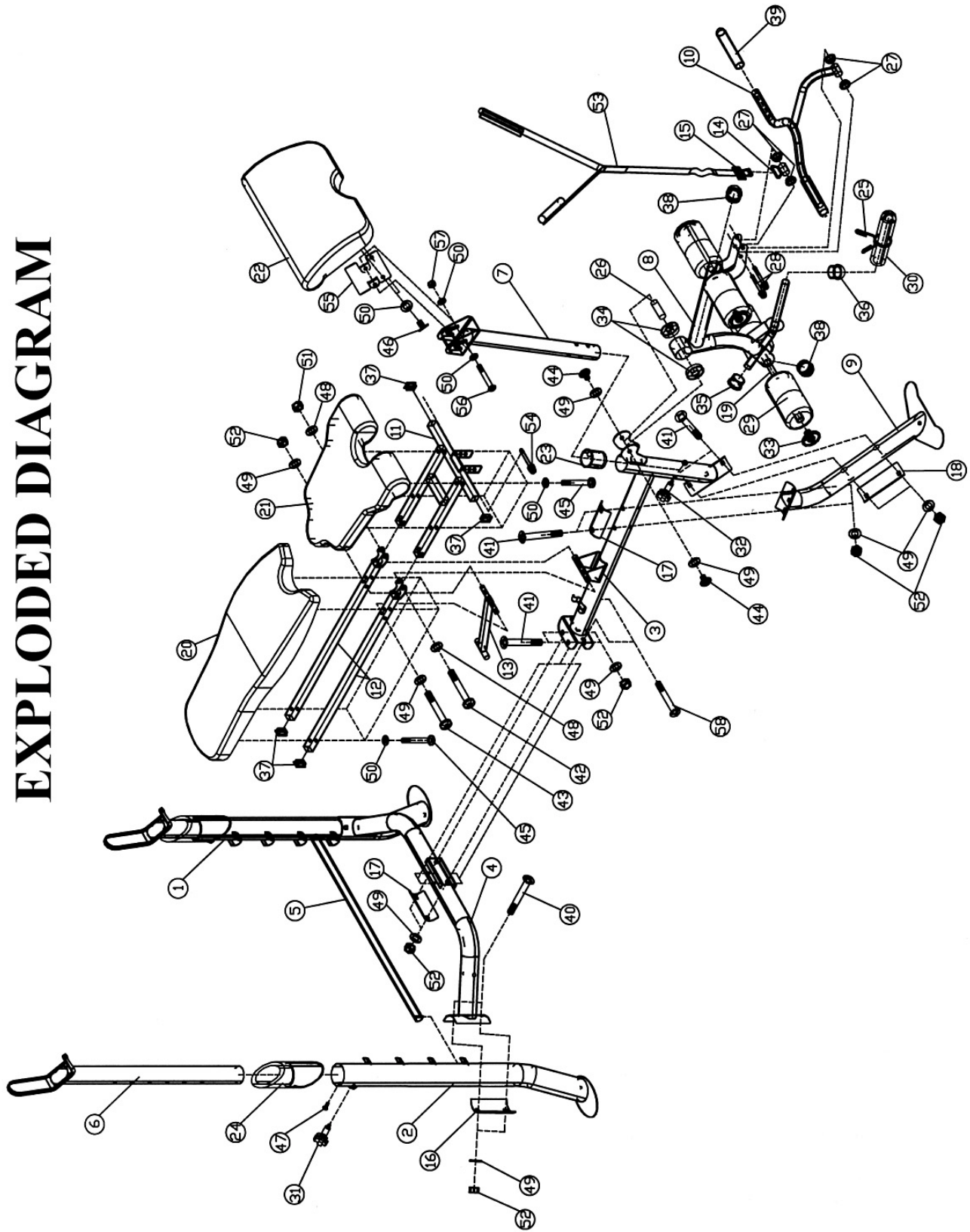

**PARTS LIST**

<b>KEY NO.</b>	<b>DESCRIPTION</b>	<b>QUANTITY</b>
1	Left Upright Beam	1
2	Right Upright Beam	1
3	Main Seat Support	1
4	Cross Brace	1
5	Backrest Adjustment Bar	1
6	Crutch	2
7	Arm Curl Stand	1
8	Leg Developer	1
9	Front Post	1
10	Arm Curl Handle	1
11	Seat Support	1
12	Backrest Support	2
13	Backrest Incline Support	1
14	Abdominal Strap Connector	1
15	Strap Buckle	1
16	5 1/2" Bent Bracket	2
17	4 3/4" Bent Bracket	2
18	6 1/4" Bent Bracket	1
19	Foam Tube	2
20	Backrest Board	1
21	Seat	1
22	Arm Curl Pad	1
23	2 3/8" x 2" Sleeve	1
24	9 1/2" x Ø 3" Crutch Sleeve	2
25	Spring Clip	1
26	Axle	1
27	Ø 1" Bushing	4
28	3" Lock Pin	2
29	Foam Roll	4
30	Olympic Sleeve	1
31	M18 Lock Knob	2
32	M10 Lock Knob	1
33	Foam Roll End Cap	4
34	Ø 2 3/8" Leg Developer Bushing	2
35	Ø 1" End Cap	1
36	Ø 1" Cone-shaped End Cap	1
37	1" Square End Cap	4
38	Ø 2" End Cap	2
39	6" Arm Curl Handle Grip	2
40	M10 x 3 3/4" Carriage Bolt	4
41	M10 x 3 1/8" Carriage Bolt	6
42	M12 x 7 5/8" Allen Bolt	1
43	M10 x 7 1/4" Allen Bolt	1
44	M10 x 5/8" Allen Bolt	2
45	M8 x 1 5/8" Allen Bolt	8
46	M8 x 5/8" Allen Bolt	2
47	ST4 Philips Screw	2
48	Ø 1" Washer	2
49	Ø 3/4" Washer	16
50	Ø 5/8" Washer	12
51	M12 Aircraft Nut	1
52	M10 Aircraft Nut	13
53	Abdominal Strap	1
54	4" Lock Pin	1
55	Arm Curl Bracket	1
56	M8 x 3 1/2" Allen Bolt	1
57	M8 Aircraft Nut	1
58	M10 x 3 3/8" Carriage Bolt	2

# **IMPEX INC.**

## **LIMITED WARRANTY**

IMPEX Inc. ("IMPEX<sup>®</sup>") warrants this product to be free from defects in workmanship and material, under normal use and service conditions, for a period of two years on the Frame from the date of purchase. This warranty extends only to the original purchaser. IMPEX's obligation under this Warranty is limited to replacing or repairing, at IMPEX's option.

All returns must be pre-authorized by IMPEX. Pre-authorization may be obtained by calling IMPEX Customer Service Department at 1-800-999-8899. All freights on products returned to IMPEX must be prepaid by the customer. This warranty does not extend to any product or damage to a product caused by or attributable to freight damage, abuse, misuse, improper or abnormal usage or repairs not provided by a IMPEX authorized service center or for products used for commercial or rental purposes. No other warranty beyond that specifically set forth above is authorized by IMPEX.

IMPEX is not responsible or liable for indirect, special or consequential damages arising out of or in connection with the use or performance of the product or other damages with respect to any economic loss, loss of property, loss of revenues or profits, loss of enjoyments or use, costs of removal, installation or other consequential damages or whatsoever natures. Some states do not allow the exclusion or limitation of incidental or consequential damages. Accordingly, the above limitation may not apply to you.

The warranty extended hereunder is in lieu of any and all other warranties and any implied warranties of merchantability or fitness for a particular purpose is limited in its scope and duration to the terms set forth herein. Some states do not allow limitations on how long an implied warranty lasts. Accordingly, the above limitation may not apply to you.

This warranty gives you specific legal right. You may also have other rights which vary from state to state.

**Register on-line [www.impex-fitness.com](http://www.impex-fitness.com)**

**IMPEX<sup>®</sup> INC.  
14777 Don Julian  
City of Industry, CA 91746**

### **ORDERING REPLACEMENT PARTS**

Replacement parts can be ordered by calling our Customer Service Department toll-free at 1-800-999-8899 during our regular business hours: Monday through Friday, 9 am until 5 pm Pacific standard time.

**[info@impex-fitness.com](mailto:info@impex-fitness.com)**

When ordering replacement parts, always give the following information.

1. Model
2. Description of Parts
3. Part Number
4. Date of Purchase

## Free Manuals Download Website

<http://myh66.com>

<http://usermanuals.us>

<http://www.somanuals.com>

<http://www.4manuals.cc>

<http://www.manual-lib.com>

<http://www.404manual.com>

<http://www.luxmanual.com>

<http://aubethermostatmanual.com>

Golf course search by state

<http://golfingnear.com>

Email search by domain

<http://emailbydomain.com>

Auto manuals search

<http://auto.somanuals.com>

TV manuals search

<http://tv.somanuals.com>