

NOTE:  
Please read all instructions  
carefully before using this  
product

Table of Contents

Safety Notice

Hardware Identifier

Assembly Instruction

Parts List

Warranty

Ordering Parts

Model  
TC-6000

Retain This  
Manual for  
Reference

100614

OWNER'S  
MANUAL

# IMPEX

## MARCY® POWER STATION TC-6000

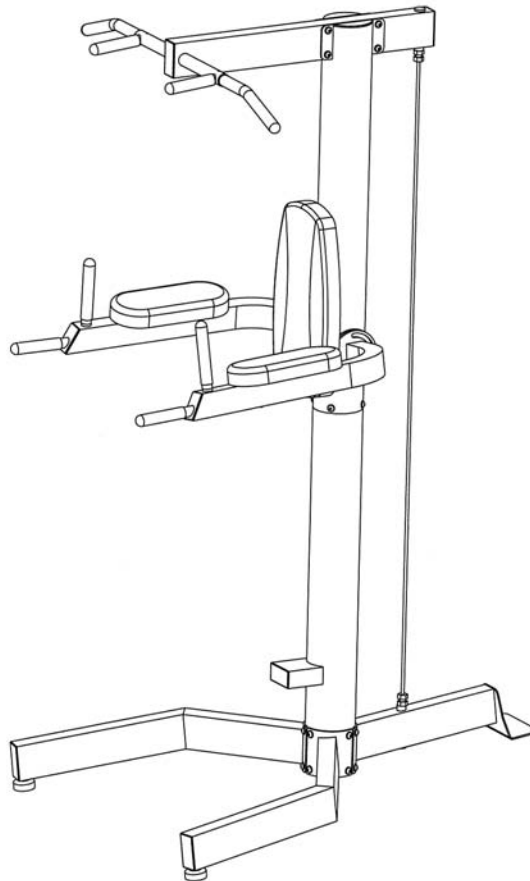

**IMPEX® INC.**

14777 DON JULIAN RD., CITY OF INDUSTRY, CA 91746

Tel: (800) 999-8899 Fax: (626) 961-9966

[www.impex-fitness.com](http://www.impex-fitness.com)

[info@impex-fitness.com](mailto:info@impex-fitness.com)

## TABLE OF CONTENTS

BEFORE YOU BEGIN.....	1
IMPORTANT SAFETY NOTICES.....	2
HARDWARE IDENTIFIER.....	4
ASSEMBLY INSTRUCTIONS.....	5
EXPLODED DIAGRAM.....	9
PARTS LIST.....	10
WARRANTY.....	11
ORDERING PARTS.....	11

---

## BEFORE YOU BEGIN

Thank you for selecting the MARCY TC-6000 by IMPEX<sup>®</sup> INC. For your safety and benefit, read this manual carefully before using the machine. As a manufacturer, we are committed to provide you complete customer satisfaction. If you have any questions, or find there are missing or damaged parts, we guarantee you complete satisfaction through direct assistance from our factory. To avoid unnecessary delays, *please call our TOLL-FREE customer service number*. Our Customer Service Agents will provide immediate assistance to you.

**Toll-Free Customer Service Number**

**1-800-999-8899**

**Mon. - Fri. 9 a.m. - 5 p.m. PST**

**[www.impex-fitness.com](http://www.impex-fitness.com)**

**[info@impex-fitness.com](mailto:info@impex-fitness.com)**

# **IMPORTANT SAFETY NOTICE**

## **PRECAUTIONS**

This exercise machine is built for optimum safety. However, certain precautions apply whenever you operate a piece of exercise equipment. Be sure to read the entire manual before you assemble or operate your machine. In particular, note the following safety precautions:

1. **Keep children and pets away from the machine at all times. DO NOT leave children unattended in the same room with the machine.**
2. Only one person at a time should use the machine.
3. If the user experiences dizziness, nausea, chest pain, or any other abnormal symptoms, STOP the workout at once. CONSULT A PHYSICIAN IMMEDIATELY.
4. Position the machine on a clear, leveled surface. DO NOT use the machine near water or outdoors.
5. Keep hands away from all moving parts.
6. Always wear appropriate workout clothing when exercising. DO NOT wear robes or other clothing that could become caught in the machine. Running or aerobic shoes are also required when using the machine.
7. Use the machine only for its intended use as described in this manual. DO NOT use attachments not recommended by the manufacturer.
8. Do not place any sharp object around the machine.
9. Disabled person should not use the machine without a qualified person or physician in attendance.
10. Before using the machine to exercise, always do stretching exercises to properly warm up.
11. Never operate the machine if the machine is not functioning properly.

## **CARE AND MAINTENANCE**

1. Inspect and tighten all parts before using the machine.
2. The machine can be cleaned using a damp cloth and mild non-abrasive detergent. DO NOT use solvents.
3. Maximum user's weight: 300 lbs.

**WARNING: BEFORE BEGINNING ANY EXERCISE PROGRAM, CONSULT YOUR PHYSICIAN. THIS IS ESPECIALLY IMPORTANT FOR INDIVIDUALS OVER THE AGE OF 35 OR PERSONS WITH PRE-EXISTING HEALTH PROBLEMS. READ ALL INSTRUCTIONS BEFORE USING ANY FITNESS EQUIPMENT. IMPEX INC. ASSUMES NO RESPONSIBILITY FOR PERSONAL INJURY OR PROPERTY DAMAGE SUSTAINED BY OR THROUGH THE USE OF THIS PRODUCT.**

**SAVE THESE INSTRUCTIONS.**

# WARNING LABEL PLACEMENT

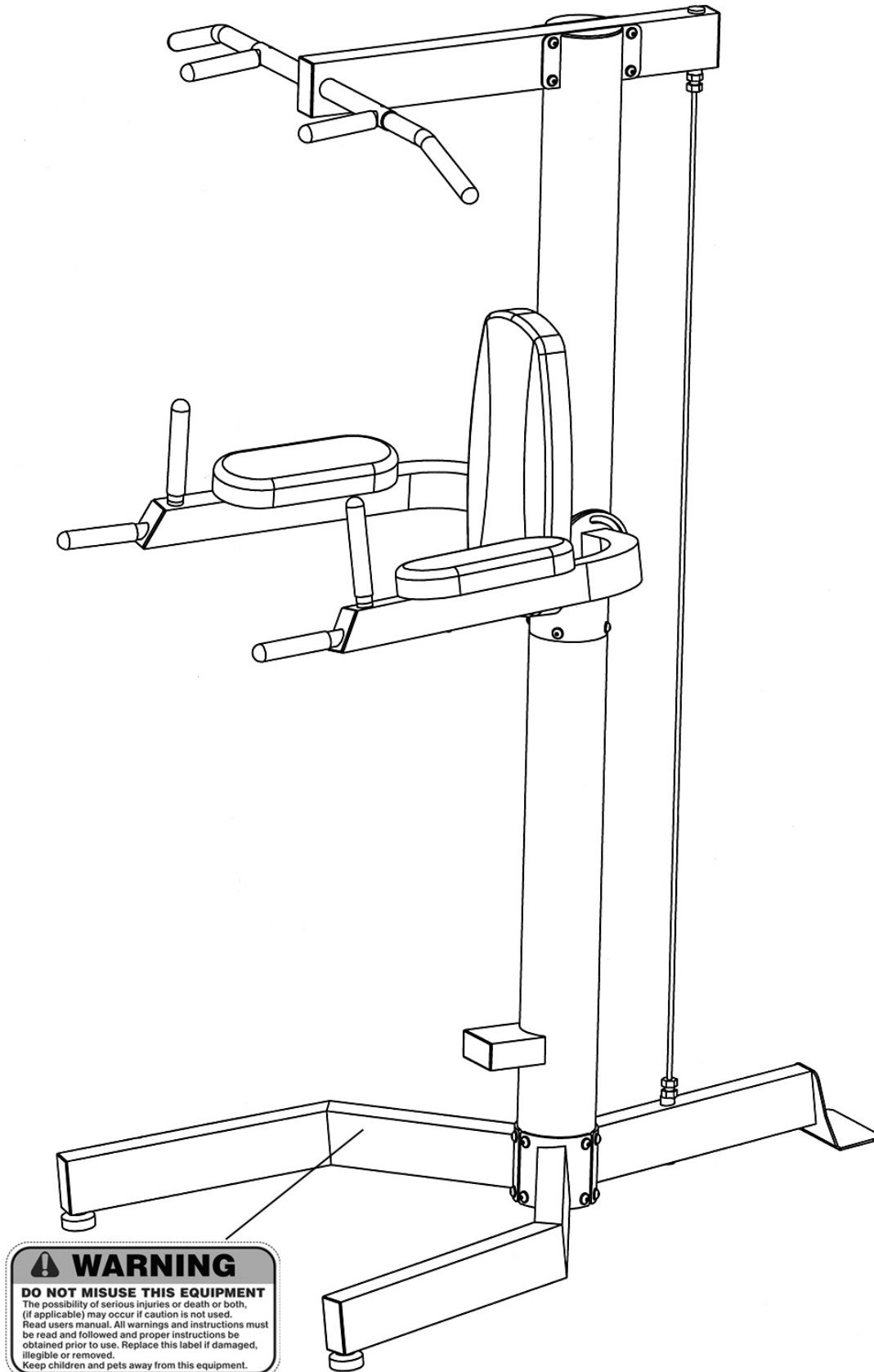

The warning label shown here has been placed on the Stabilizer. If the labels are missing or illegible, please call customer service at 1-800-888-8899 for replacements. Apply the labels in the location shown.

# HARDWARE PACK

NOTE: The following parts are not drawn to scale. Please use your own ruler or scale to measure the size.

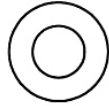

#24  $\varnothing \frac{3}{4}$ " Washer  
(Qty 28)



#25  $\varnothing \frac{5}{8}$ " Washer  
(Qty 4)



#26 M10 Aircraft Nut  
(Qty 4)



#27 M5 x  $\frac{1}{2}$ " Allen Screw  
(Qty 2)

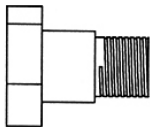

#19 M10 x  $\frac{1}{2}$ " Hex Bolt  
(Qty 4)



#28  $\varnothing \frac{3}{4}$ " Lock Washer  
(Qty 12)

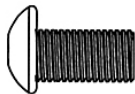

#20 M10 x  $\frac{3}{4}$ " Allen Bolt (Qty 18)

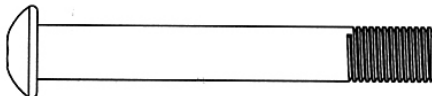

#21 M10 x 2  $\frac{7}{8}$ " Allen Bolt (Qty 4)

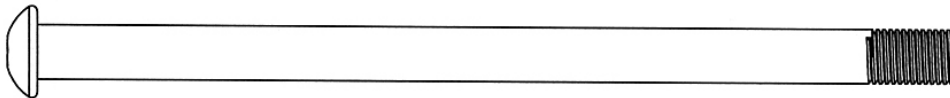

#22 M10 x 6  $\frac{3}{4}$ " Allen Bolt (Qty 2)

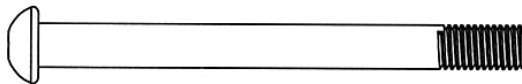

#23 M8 x 3  $\frac{1}{2}$ " Allen Bolt (Qty 4)

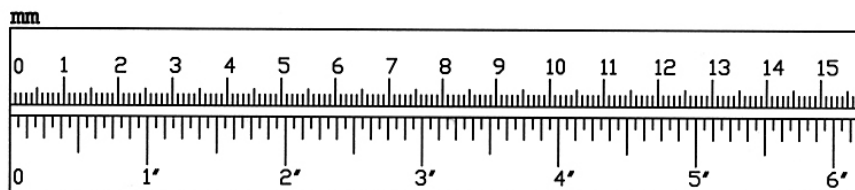

# ASSEMBLY INSTRUCTION

Tools Required for Assembling the Machine: Two Adjustable Wrenches and Allen Wrenches

**NOTE:** It is strongly recommended that two or more people assemble this machine to avoid possible injury.

## STEP 1 (See Diagram 1)

- A.) **Do not tighten all Bolts until instructed to do so.**
- B.) Attach the Lower Vertical Frame (#2) to the Rear Stabilizer (#8). Secure it with four M10 x  $\frac{3}{4}$ " Allen Bolts (#20), four  $\text{\O} \frac{3}{4}$ " Lock Washers (#28), and four  $\text{\O} \frac{3}{4}$ " Washers (#24).
- C.) Attach the Left Stabilizer (#4) to the Lower Vertical Frame. Secure it with four M10 x  $\frac{3}{4}$ " Allen Bolts (#20), four  $\text{\O} \frac{3}{4}$ " Lock Washers (#28), and four  $\text{\O} \frac{3}{4}$ " Washers (#24). Repeat the same procedure to install the Right Stabilizer (#5) to the Lower Vertical Frame.
- D.) **Securely tighten all Bolts.**
- E.) Use the Level Knob (#17) under the Left and Right Stabilizer to stabilize the equipment.

**DIAGRAM 1**

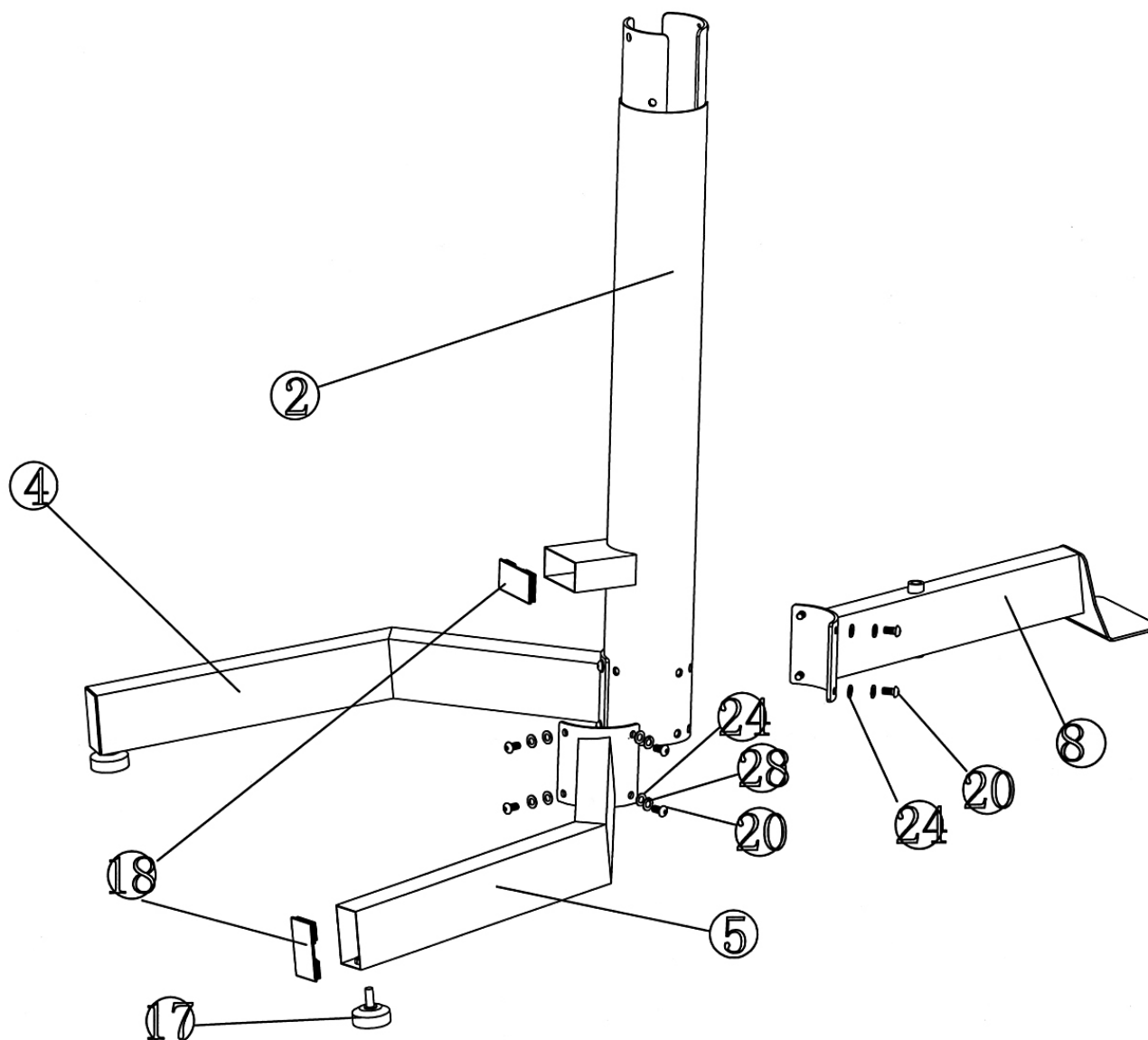

## STEP-2 (See Diagram 2)

- A.) Attach the Upper Vertical Frame (#1) onto the Lower Vertical Frame (#2). Secure it with six M10 x  $\frac{3}{4}$ " Allen Bolts (#20) and six  $\varnothing \frac{3}{4}$ " Washers (#24).
- B.) Attach the Right Dip Support (#6) to the Upper Vertical Frame. Secure it with two M10 x  $\frac{1}{2}$ " Allen Bolts (#19). **Do not over tighten the Bolt. Make sure the Dip Support is able to fold up.**
- C.) Thread the Vertical Support (#10) onto the Right Dip Support.
- D.) Repeat B & C to install the Left Dip Support (#7).
- E.) Attach the Upper Frame (#3) onto the Upper Vertical Frame. Secure it with four M10 x 2  $\frac{7}{8}$ " Allen Bolts (#21), eight  $\varnothing \frac{3}{4}$ " Washers (#24), and four M10 Aircraft Nuts (#26).
- F.) Insert the Chin-up Bar (#9) to Upper Frame from both ends. Secure each Chin-up Bar with one M5 x  $\frac{1}{4}$ " Allen Bolt (#27).
- G.) Fold up the Left & Right Dip-Support when doing Chin-up exercises.

DIAGRAM 2

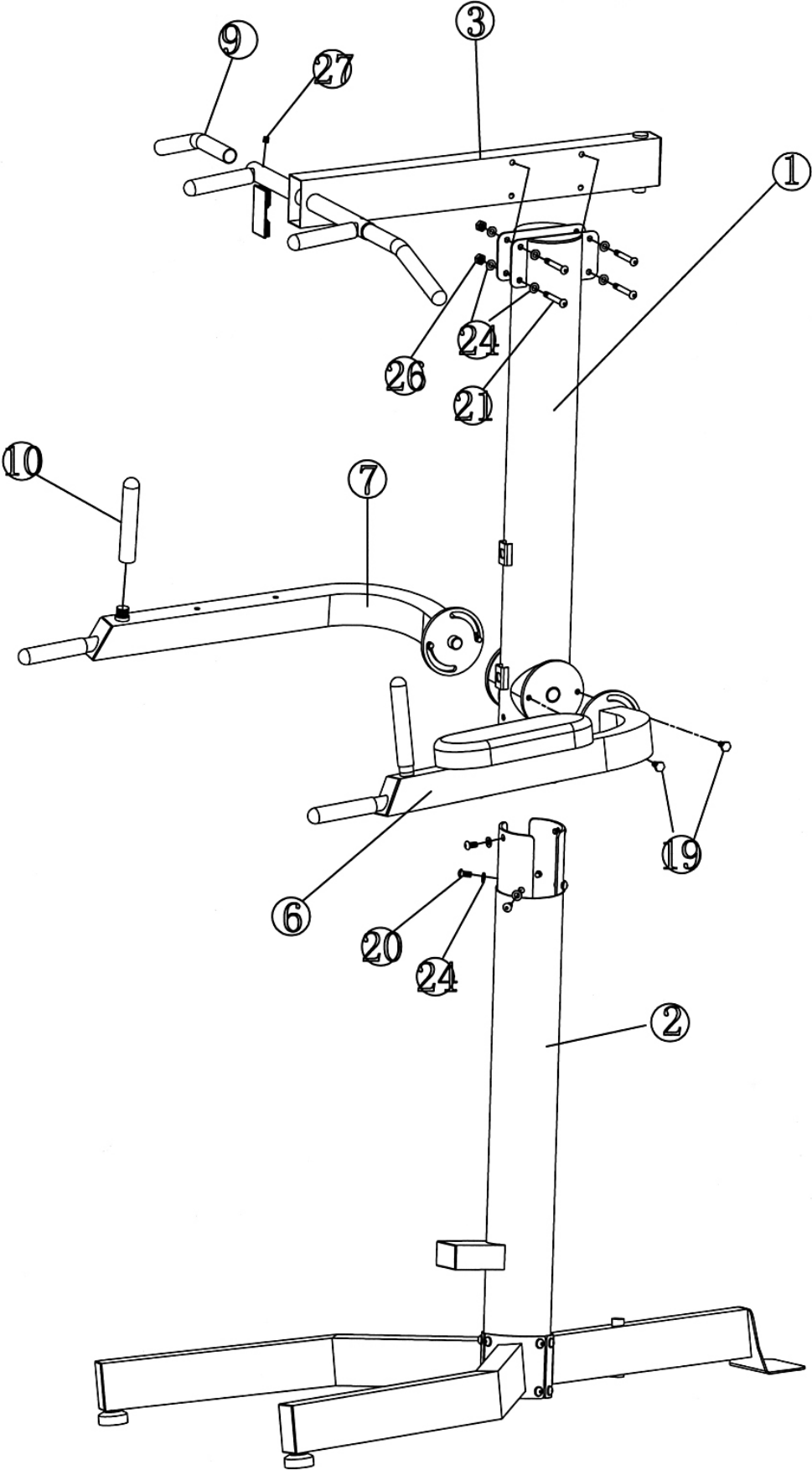



### STEP 3 (See Diagram 3)

- A.) Attach the Backrest Pad (#11) to Upper Vertical Frame (#1). Secure it with two M10 x 6  $\frac{3}{4}$ " Allen Bolts (#22) and two  $\text{\O} \frac{3}{4}$ " Washers (#24).
- B.) Attach the Arm Pad to Left and Right Dip Support (#6 & #7). Secure each Arm Pad with two M8 x 3  $\frac{1}{2}$ " Allen Bolts (#23) and two  $\text{\O} \frac{5}{8}$ " Washers (#25).
- C.) Thread the Cable (#13) into Upper Frame (#3) and Rear Stabilizer (#8) to stabilize the equipment.

### DIAGRAM 3

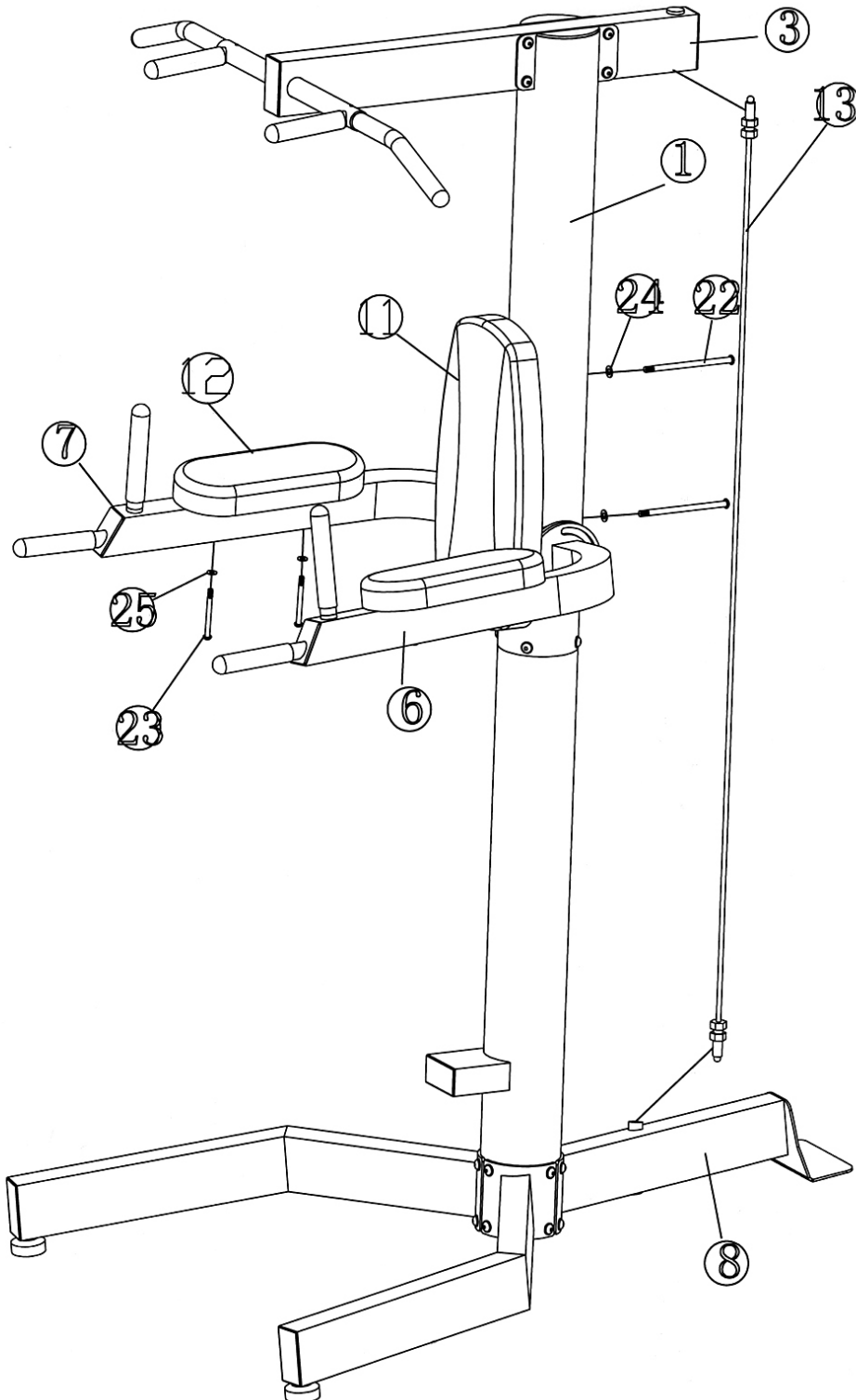

# EXPLODED DIAGRAM

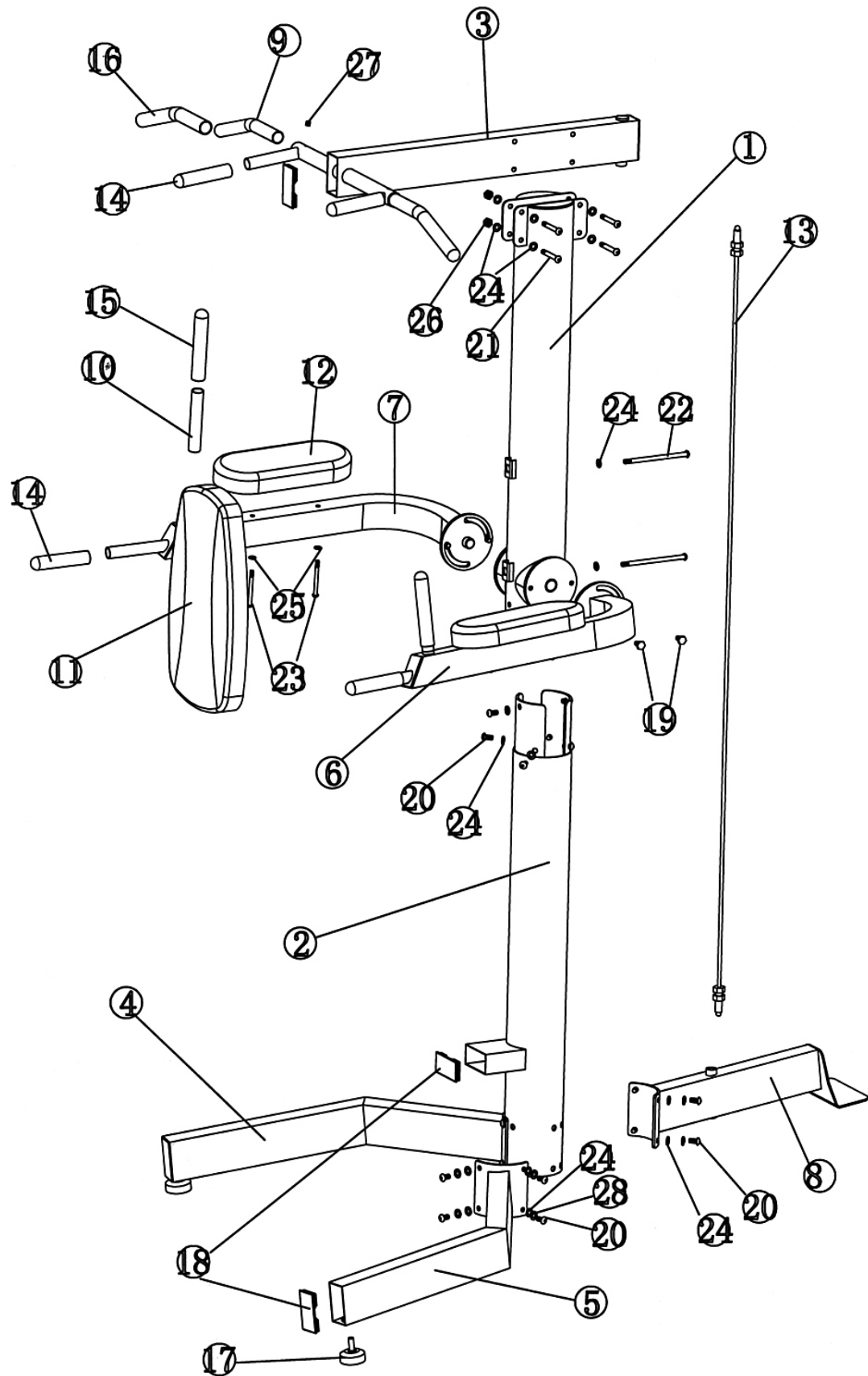

## Parts list

KEY NO.	DESCRIPTION	Q'ty
1	Upper Vertical Frame	1
2	Lower Vertical Frame	1
3	Upper Frame	1
4	Left Stabilizer	1
5	Right Stabilizer	1
6	Right Dip Support	1
7	Left Dip Support	1
8	Rear Stabilizer	1
9	Chin-up Bar	2
10	Vertical Handle	2
11	Backrest Pad	1
12	Arm Pad	2
13	Cable	1
14	5 3/8" Grip	4
15	7" Grip	2
16	12" Grip	2
17	Level Knob	2
18	2" x 4" End Cap	5
19	M10 x 1/2" Hex Bolt	4
20	M10 x 3/4" Allen Bolt	18
21	M10 x 2 7/8" Allen Bolt	4
22	M10 x 6 3/4" Allen Bolt	2
23	M8 x 3 1/2" Allen Bolt	4
24	Ø 3/4" Washer	28
25	Ø 5/8" Washer	4
26	M10 Aircraft Nut	4
27	M5 x 1/4" Allen Screw	2
28	Ø 3/4" Lock Washer	12

# IMPEX<sup>®</sup> INC.

## LIMITED WARRANTY

IMPEX Inc. ("IMPEX<sup>®</sup>") warrants this product to be free from defects in workmanship and material, under normal use and service conditions, for a period of two years on the Frame from the date of purchase. This warranty extends only to the original purchaser. IMPEX's obligation under this Warranty is limited to replacing or repairing, at IMPEX's option.

All returns must be pre-authorized by IMPEX. Pre-authorization may be obtained by calling IMPEX Customer Service Department at 1-800-999-8899. All freights on products returned to IMPEX must be prepaid by the customer. This warranty does not extend to any product or damage to a product caused by or attributable to freight damage, abuse, misuse, improper or abnormal usage or repairs not provided by an IMPEX authorized service center or for products used for commercial or rental purposes. No other warranty beyond that specifically set forth above is authorized by IMPEX.

IMPEX is not responsible or liable for indirect, special or consequential damages arising out of or in connection with the use or performance of the product or other damages with respect to any economic loss, loss of property, loss of revenues or profits, loss of enjoyments or use, costs of removal, installation or other consequential damages or whatsoever natures. Some states do not allow the exclusion or limitation of incidental or consequential damages. Accordingly, the above limitation may not apply to you.

The warranty extended hereunder is in lieu of any and all other warranties and any implied warranties of merchantability or fitness for a particular purpose is limited in its scope and duration to the terms set forth herein. Some states do not allow limitations on how long an implied warranty lasts. Accordingly, the above limitation may not apply to you.

This warranty gives you specific legal right. You may also have other rights which vary from state to state. Register on-line [www.impex-fitness.com](http://www.impex-fitness.com)

**IMPEX<sup>®</sup> INC.**  
**14777 Don Julian**  
**City of Industry, CA 91746**

### **ORDERING REPLACEMENT PARTS**

Replacement parts can be ordered by calling our Customer Service Department toll-free at **1-800-999-8899** during our regular business hours: Monday through Friday, 9 am until 5 pm Pacific standard time.

**info@impex-fitness.com**

When ordering replacement parts, always give the following information.

1. Model
2. Description of Parts
3. Part Number
4. Date of Purchase

## Free Manuals Download Website

<http://myh66.com>

<http://usermanuals.us>

<http://www.somanuals.com>

<http://www.4manuals.cc>

<http://www.manual-lib.com>

<http://www.404manual.com>

<http://www.luxmanual.com>

<http://aubethermostatmanual.com>

Golf course search by state

<http://golfingnear.com>

Email search by domain

<http://emailbydomain.com>

Auto manuals search

<http://auto.somanuals.com>

TV manuals search

<http://tv.somanuals.com>