

# *Grizzly* *Industrial, Inc.*®

## MODEL H8067 FLAT IRON STYLE MANDOLIN KIT OWNER'S MANUAL



COPYRIGHT © NOVEMBER, 2006 BY GRIZZLY INDUSTRIAL, INC.  
**WARNING: NO PORTION OF THIS MANUAL MAY BE REPRODUCED IN ANY SHAPE  
OR FORM WITHOUT THE WRITTEN APPROVAL OF GRIZZLY INDUSTRIAL, INC.**  
#BL8554 PRINTED IN JAPAN



# **WARNING!**

**Some dust created by power sanding, sawing, grinding, drilling, and other construction activities contains chemicals known to the State of California to cause cancer, birth defects or other reproductive harm. Some examples of these chemicals are:**

- **Lead from lead-based paints.**
- **Crystalline silica from bricks, cement and other masonry products.**
- **Arsenic and chromium from chemically-treated lumber.**

**Your risk from these exposures varies, depending on how often you do this type of work. To reduce your exposure to these chemicals: Work in a well ventilated area, and work with approved safety equipment, such as those dust masks that are specially designed to filter out microscopic particles.**

# Table of Contents

|   |           |
|---|-----------|
| <b>SECTION 1: SAFETY</b> .....          | <b>2</b>  |
| <b>SECTION 2: INTRODUCTION</b> .....    | <b>3</b>  |
| Foreword .....                          | 3         |
| Contact Info .....                      | 3         |
| <b>SECTION 3: PARTS INVENTORY</b> ..... | <b>4</b>  |
| Inventory .....                         | 4         |
| Supplies/Tools .....                    | 4         |
| Identification .....                    | 5         |
| <b>SECTION 4: SANDING</b> .....         | <b>6</b>  |
| Body .....                              | 6         |
| Neck .....                              | 6         |
| Fretboard .....                         | 6         |
| <b>SECTION 5: ASSEMBLY</b> .....        | <b>7</b>  |
| Neck to the Body .....                  | 7         |
| Fretboard .....                         | 10        |
| Shaping Neck .....                      | 11        |
| Shaping Fretboard .....                 | 11        |
| Final Sanding .....                     | 12        |
| Finishing .....                         | 13        |
| Nut .....                               | 14        |
| Tailpiece .....                         | 14        |
| Tuning Machines .....                   | 15        |
| Fitting Bridge .....                    | 15        |
| Placing Bridge .....                    | 16        |
| Winding Strings .....                   | 17        |
| String Height .....                     | 17        |
| Tuning .....                            | 18        |
| <b>SECTION 6: REFERENCE INFO</b> .....  | <b>19</b> |
| Accessories .....                       | 19        |
| <b>WARRANTY AND RETURNS</b> .....       | <b>21</b> |

# SECTION 1: SAFETY

---

---

## WARNING

Always wear safety glasses or goggles when operating equipment. Everyday glasses or reading glasses are not safety glasses. Be certain the safety glasses you wear meet the appropriate standards of the American National Standards Institute (ANSI).

Because there are various ways to cut and join wood, you can make substitutions for the methods stated in this plan. We try to suggest the easiest methods possible. However, only you know your skills with each piece of machinery. Never compromise your safety by using a cutting method with which you are not comfortable. Instead, find an alternative approach that will yield the same result.

## WARNING

These instructions assume that you are intimately familiar with the safe operation and use of wood-working machinery and woodworking tools, and understand the techniques used to reproduce this project. If you do not qualify for both of these criteria, **STOP building this project for your own safety**. Read and understand the owners manual for the machinery you intend to use, take a wood-working class or visit your local library for more information. Woodworking machinery and tools are inherently dangerous because they use sharp edges that can and will cause serious personal injury including amputation and death. Do not underestimate the ability of these tools and machinery to cause injury. Never operate any tool without all guards in place and always wear approved safety glasses. For your own safety, please heed this warning.



# SECTION 2: INTRODUCTION

---

---

## Foreword

---

---

We are proud to offer the Model H8067 Flat Iron Style Mandolin Kit. This kit is a part of a growing Grizzly family of fine woodworking projects. When assembled according to the guidelines set forth in this manual, you can expect years of enjoyment from your mandolin.

We are pleased to provide this manual for the Model H8067 Flat Iron Style Mandolin Kit. It was written to guide you through assembly, review safety considerations, and cover general information. It represents our effort to produce the best documentation possible.

## Contact Info

---

---

If you have any comments regarding this manual, please write to us at the address below:

Grizzly Industrial, Inc.  
c/o Technical Documentation Manager  
P.O. Box 2069  
Bellingham, WA 98227-2069  
Email: manuals@grizzly.com

We stand behind our products. If you have any service questions or parts requests, please call or write us at the location listed below.

Grizzly Industrial, Inc.  
1203 Lycoming Mall Circle  
Muncy, PA 17756  
Phone: (570) 546-9663  
Fax: (800) 438-5901  
E-Mail: techsupport@grizzly.com  
Web Site: <http://www.grizzly.com>



# SECTION 3: PARTS INVENTORY

## Inventory

| REF | PART #    | DESCRIPTION         | QTY |
|-----|-----------|---------------------|-----|
| 1   | PH8067001 | Mandolin Body       | 1   |
| 2   | PH8067002 | Neck                | 1   |
| 3   | PH8067003 | Fretboard           | 1   |
| 4   | PH8067004 | Bridge              | 1   |
| 5   | PH8067005 | Tuning Machines     | 2   |
| 6   | PH8067006 | Tailpiece           | 1   |
| 7   | PH8067007 | Nut                 | 1   |
| 8   | PH8067008 | Endpin              | 1   |
| 9   | PH8067009 | Dowels              | 2   |
| 10  | PH8067010 | Strings             | 8   |
| 11  | PH8067011 | Bushings            | 8   |
| 12  | PH8067012 | #3 x 3/4" SS Screw  | 1   |
| 13  | PH8067013 | #1 x 3/8" SS Screws | 14  |

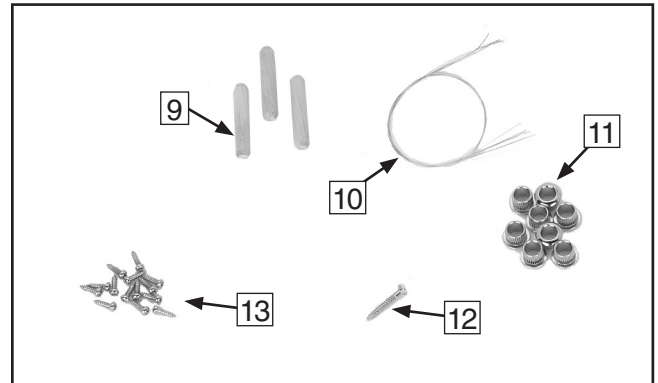

Figure 2. Additional components.

## Supplies/Tools

The majority of the wood components in this kit come fully machined and ready for assembly. A small amount of sanding and finish work is needed to complete the mandolin.

### Recommended Tools & Supplies:

- Wood Glue—Titebond Original Wood Glue
- #80 to #320 Sanding Paper
- Flexible Sanding Block
- “000” Grade Steel Wool
- Clamps or Rubber Strips (made from cut up inner tubes)
- Electric/Cordless Drill
- Drill Bit (1/16")
- Small Brad Nails
- Wire Cutters
- Razor Blades
- Chisel
- Phillips Screwdriver
- Masking Tape
- Lightweight Hammer
- Rubber Dead Blow Hammer
- Steel Straight Edge
- Sharp Pencil
- File Assortment
- Finishing Materials
- Electronic Tuner
- Coat Hanger
- NIOSH Approved Respirator
- ANSI-Approved Safety Glasses

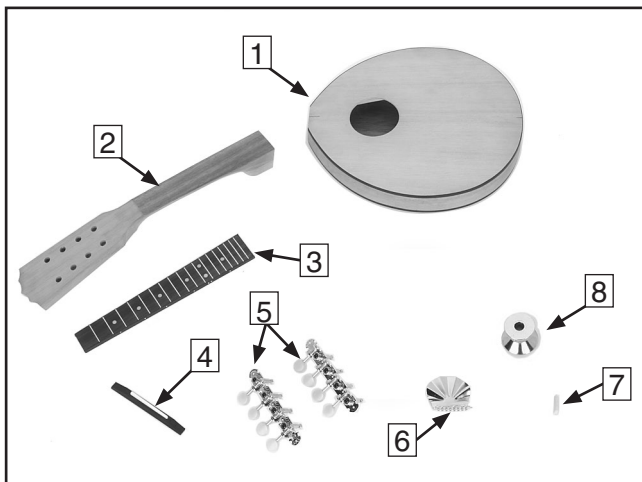

Figure 1. Boxed components.



# Identification

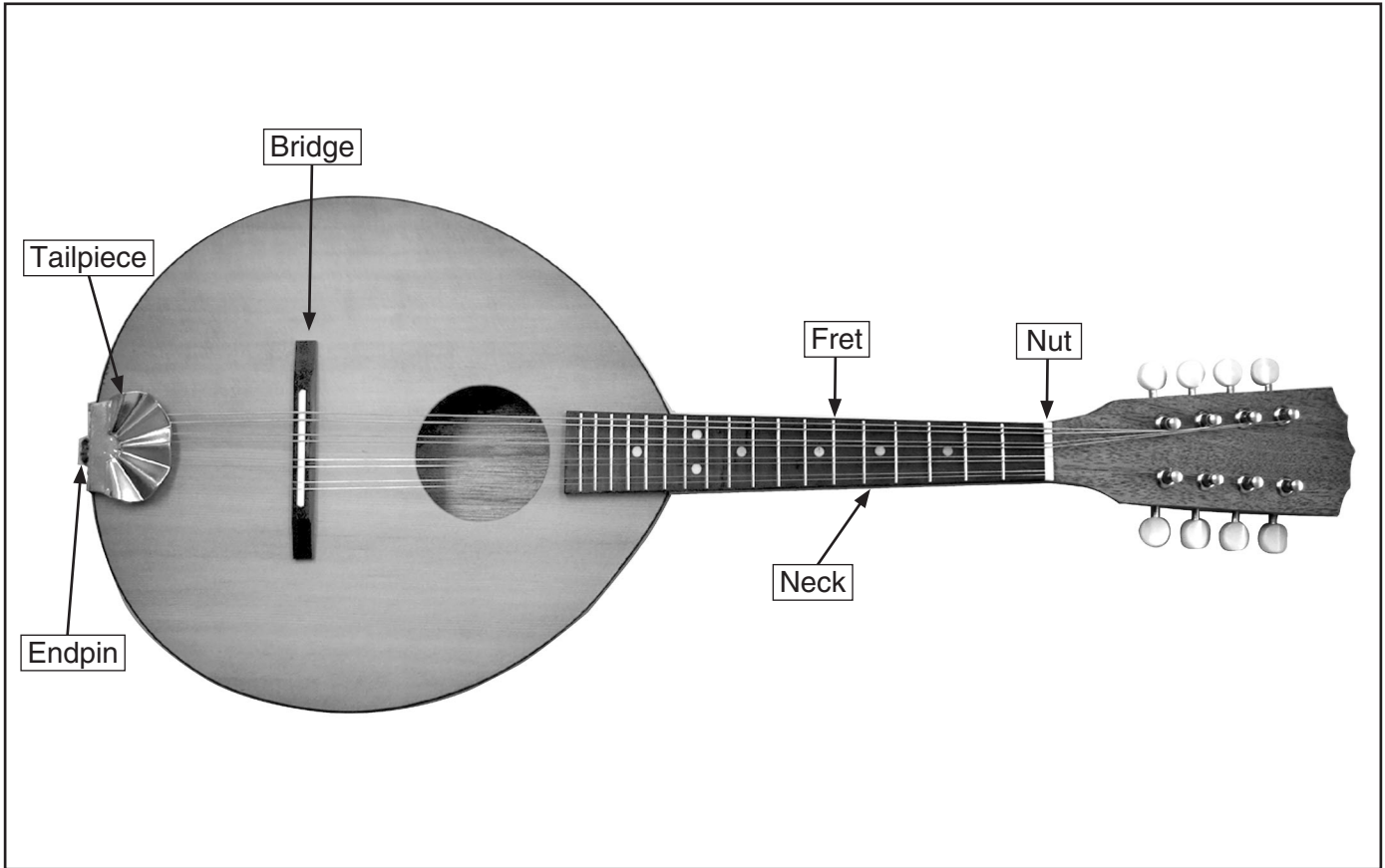

Figure 3. Model H8067 main features.

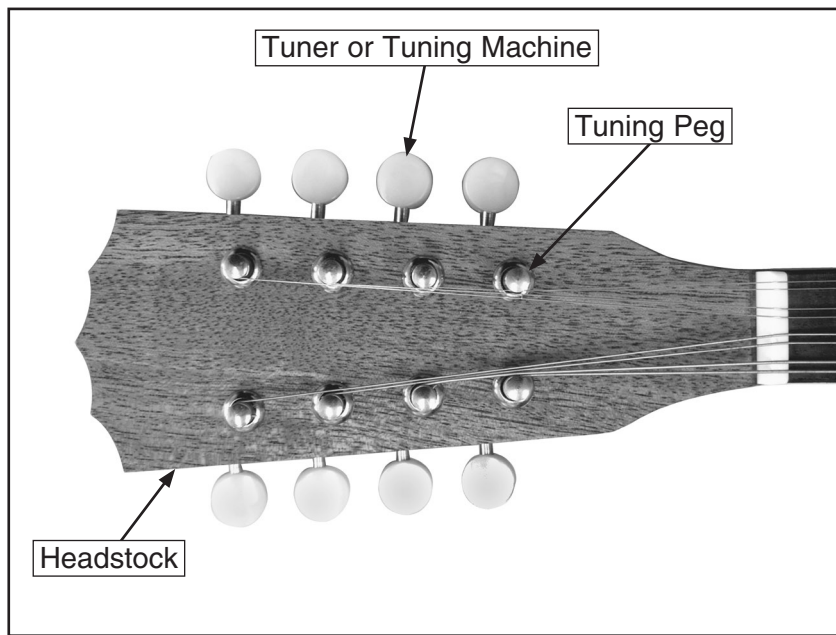

Figure 4. Model H8067 headstock features.

# SECTION 4: SANDING

---

---

## Body

---

---

The mandolin body was rough sanded at the factory. To get a good finish the body must be sanded further with a series of sandpaper grits.

**To sand the mandolin body:**

- 1. Wear a NIOSH-approved respirator and a ANSI-approved safety glasses when sanding wood!**
2. Use a sanding block with #150 grit aluminum-oxide sanding paper to sand the mandolin body until there is a consistent scratch pattern on the entire surface. Sand as little as possible in the neck area at this time  
  
*Note: When hand sanding, always sand in the same direction as the wood grain.*
3. Resand the entire mandolin body with #220 grit sanding paper and lightly round over the sound hole and edges of the body.
4. Wipe the mandolin body with a damp cloth to “raise” the wood grain.
5. Wait until the wood is dry and resand the entire body with #220 grit sandpaper.
6. Repeat **Steps 4-5**.
7. Fill the wood pores in the back of the rim with a paste filler according to the manufacturer's instructions. DO NOT fill the grain in the mandolin top (soundboard).
8. When the paste filler is dry, use “000” grade steel wool to remove the residue and polish the wood surface.

## Neck

---

---

The mandolin neck has been rough sanded at the factory. Personalize the fretboard and neck headstock with additional cutting, inlay, or design work before final sanding.

**Note:** *Take your time and consider testing your designs in scrap wood before performing the work on the actual fretboard and headstock.*

**Wait until the fretboard is installed before sanding the neck.**

## Fretboard

---

---

The fretboard requires no sanding.

**Note:** *Sanding the fretboard will affect the playability of the mandolin and could lead to permanent damage.*





# SECTION 5: ASSEMBLY

## Neck to the Body

A precise fit is important for the neck-to-body joint. This joint affects the placement of the strings and bridge, and these determine the sound quality of the mandolin. Dry fit and check all the parts before gluing.

| Components and Hardware Needed: | Qty |
|---------------------------------|-----|
| Neck .....                      | 1   |
| Body .....                      | 1   |
| Dowels.....                     | 2   |
| Tailpiece .....                 | 1   |
| Nut .....                       | 1   |

### To install the neck:

1. Test fit the neck by pushing the dowels into the body of the mandolin and sliding the neck onto the dowels as shown in **Figure 5**. DO NOT glue the joint at this time.

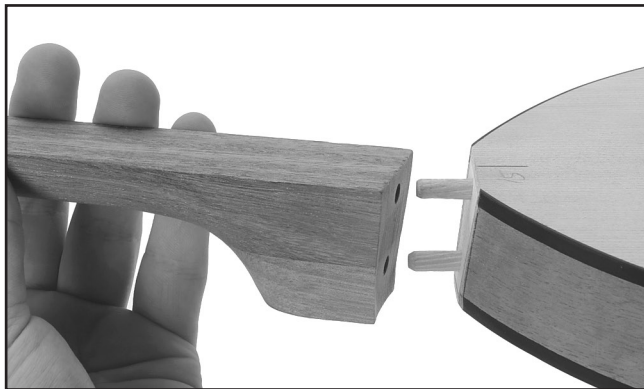

**Figure 5.** Test fitting the neck.

2. Check for gaps between the body and the neck.

—If the neck fits tightly, go on to **Step 3**.

—If there are gaps, remove the neck and dowels, and hold sandpaper on the surface of the mandolin body with the grit facing out (See **Figure 6**). Rub the neck up and down on the sandpaper until the neck conforms to the body shape.



**Figure 6.** Adjusting the fit of the neck.

3. Dry fit the neck and mark the center of both ends of the body, and the neck.
4. Place a straightedge across your center marks as shown in **Figure 7**.

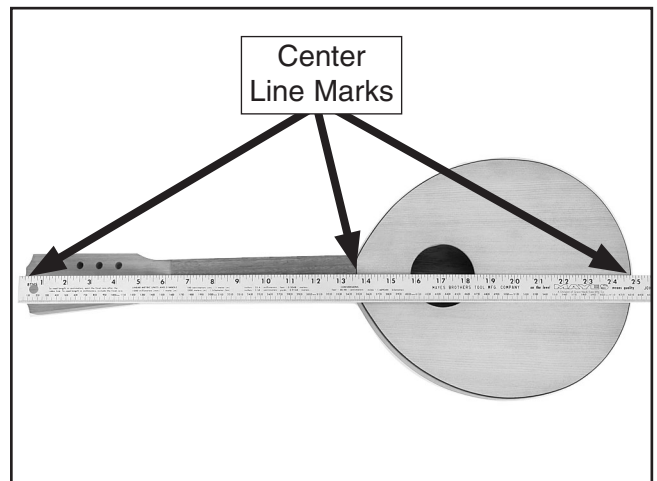

**Figure 7.** Checking neck and body alignment along center line.

—If center marks are aligned, move to **Step 6**.

—If the center marks are not aligned, move to **Step 5**.



5. Align the neck by using the sanding technique described in **Step 2**. Apply extra pressure toward the part of the neck that needs to be shifted.

**Note:** Check alignment frequently. A little bit of sanding can cause large adjustments.

6. Place the tailpiece on the edge of the soundboard and align it to the center mark.
7. Use a screw or drill a hole with a  $\frac{1}{16}$ " bit to mark the centers of the screw holes (**Figure 8**) and then set the tailpiece to the side.

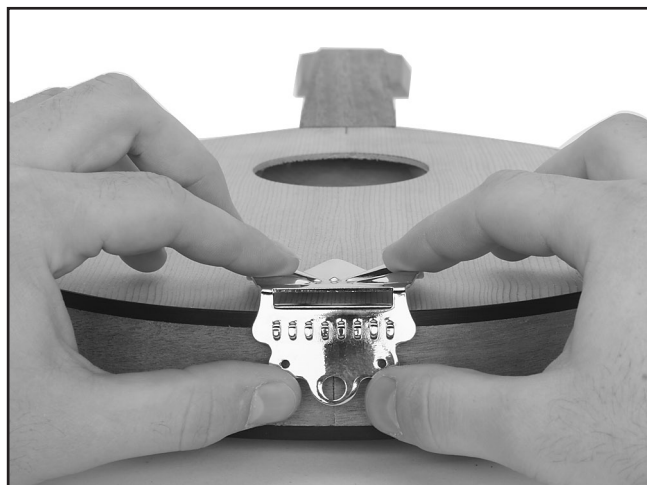

**Figure 8.** Marking tailpiece mounting holes.

**Note:** The tailpiece will not be installed until after the finish is applied to the mandolin (see **Page 14**), but the alignment of the tailpiece is easier before final sanding.

8. Place the nut at the end of the neck so it is straight across as shown in **Figure 9**, and draw a line along the bottom edge of the nut. Do not place the nut on the pegboard, the piece that slopes downward from the neck.

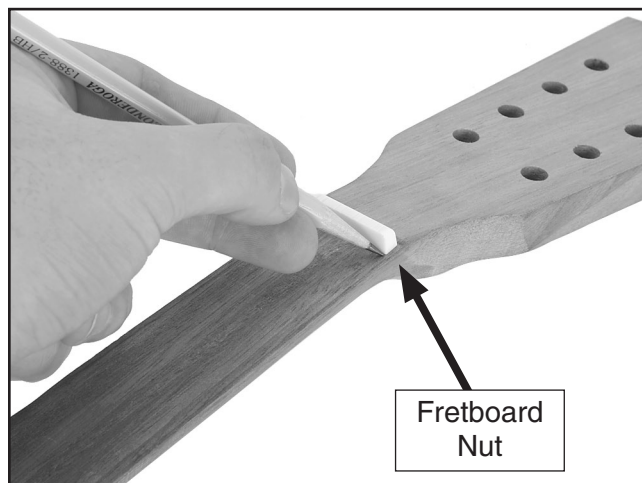

**Figure 9.** Marking the nut position.

9. Remove the nut and place the fretboard on the neck, aligning it with the top of the line drawn in **Step 8**.
10. Mark the edge of the fretboard binding onto both sides of the neck, drawing a line  $1\frac{1}{2}$ " from the body toward the headstock as shown in **Figure 10**.



**Figure 10.** Marking fretboard binding edges onto neck.

11. Remove the fretboard, turn the mandolin over, and draw a line on the end of the neck where the body intersects it as shown in **Figure 11**. Extend this line around the neck using a straightedge.

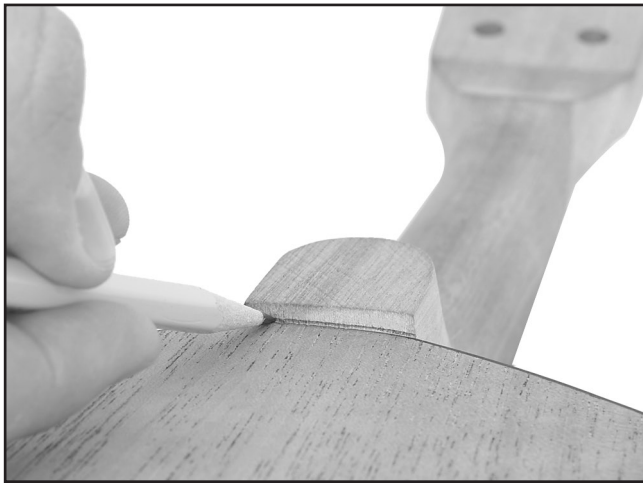

**Figure 11.** Marking bottom of neck.

12. Remove the neck from the body.
13. Use a 4-in-1 shoe rasp to file the end of the neck down to the line you drew in **Step 10** as shown in **Figure 12**. Shape both sides of the neck, then sand smooth with #220 grit sandpaper.

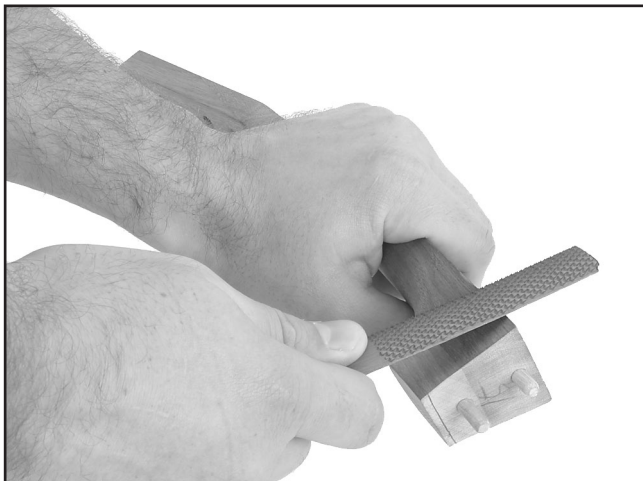

**Figure 12.** Shaping end of neck.

14. File the end of the neck down to the line you marked in **Step 11**. This will make the bottom of the neck even with the mandolin body.

15. Apply a thin coat of wood glue into the dowel holes in the mandolin body, insert the dowels and wipe away excess glue.
16. Spread a thin layer of wood glue on the heel of the neck, the dowels, and the body where it will connect to the neck.
17. Press the neck firmly onto the dowels.
18. Use rubber strips or clamps to hold the neck in place until the glue dries (**Figure 13**).

**Note:** *If using clamps, use wooden blocks and pads to protect the instrument.*



**Figure 13.** Example of gluing the neck.

19. Scrape away excess glue with a sharp knife when it sets, then allow the glue to dry for 24 hours before the next step.

# Fretboard

| Components and Hardware Needed: | Qty |
|---------------------------------|-----|
| Mandolin Body.....              | 1   |
| Fretboard .....                 | 1   |

## To attach the fretboard to the neck:

1. Check to see if the neck is flat by laying it down on an even surface.

—If neck is flat, move on to **Step 2**.

—If there are gaps between the surface and the neck, place sandpaper, grit side up, on the flat surface and rub the neck on the sandpaper (as shown in **Figure 14**) until the neck is flat.



**Figure 14.** Flattening the neck.

2. Drill positioning holes near the ends of the surface of the neck using a drill bit that is slightly smaller than the brad nails used for positioning.
3. Nail the brads into the positioning holes and use wire cutters to cut the heads off no more than an  $\frac{1}{8}$ " above the surface of the neck as shown in **Figure 15**.

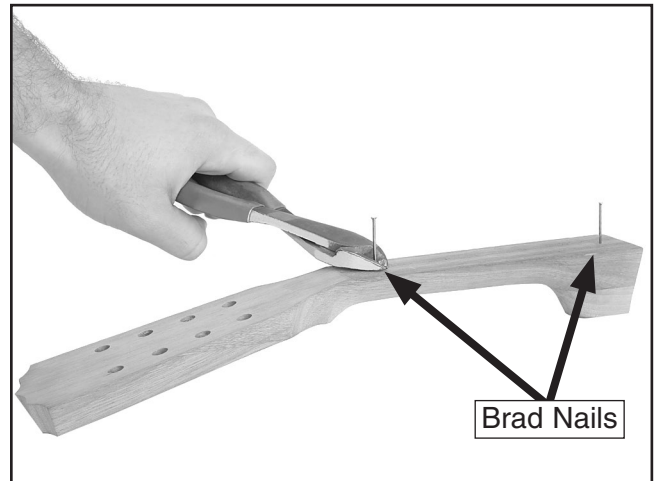

**Figure 15.** Trimming brad nails.

4. Center the fretboard on the neck, aligning the top with the line drawn in **Step 2**.

**Note:** *The neck is wider than the fretboard and will be shaped to match later.*

5. Place a wooden block on the fretboard and tap the block lightly with a hammer to leave marks in the back of the fretboard.

6. Drill  $\frac{1}{8}$ " deep holes in the marks made in **Step 5**.

**Note:** *To ensure that you do not drill through the fretboard, use a depth stop or wrap tape around the bit  $\frac{1}{8}$ " from the tip.*

7. Spread a light layer of glue on the flat surface of the neck and the back of the fretboard, then position the fretboard on the neck using the brad nails as guides.

8. Use rubber strips or clamps to hold the fretboard in place until the glue dries.

**Note:** *Use wooden blocks and pads between the clamps and the neck to protect the instrument.*

9. Scrape away the excess glue when it sets, then allow the glue to dry for 24 hours.



# Shaping Neck

The rest of the neck must be shaped to match the width of the fretboard and then sanded smooth.

**Components and Hardware Needed:** Qty  
Mandolin Body..... 1

**To shape and sand the neck:**

1. **Wear a NIOSH-approved respirator and ANSI-approved safety glasses during the next step to protect against dust!**
2. Use a 4-in-1 shoe rasp to shape the neck until it matches the width of the fretboard (**Figure 16**).

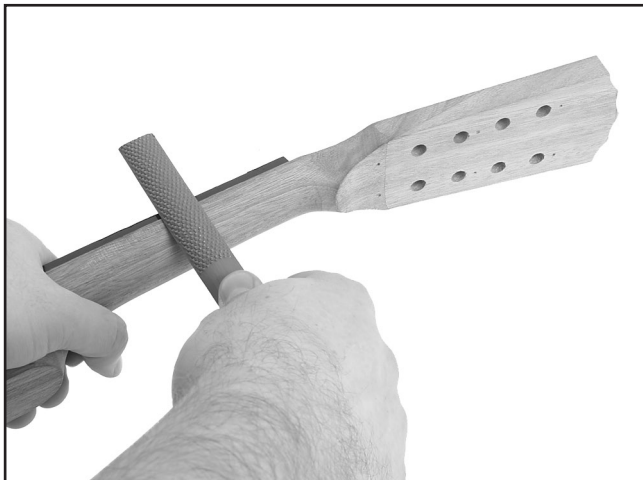

**Figure 16.** Shaping the neck.

3. Use a flexible sanding block with #150 grit aluminum-oxide sanding paper to sand the neck until there is a consistent scratch pattern on the entire surface.

**Note:** When hand sanding, always sand in the same direction as the wood grain.

4. Resand the neck with #220 grit sanding paper.
5. Wipe the neck with a damp cloth to raise the wood grain.
6. Wait until the wood is dry and resand the neck with #220 grit sandpaper. Dampen again and resand.

7. Fill the wood pores in the neck with a paste filler according to the manufacturer's instructions.
8. When the paste filler is dry, use "000" grade steel wool to remove the residue and polish the wood surface.

# Shaping Fretboard

The binding and fret ends must be filed down.

**Components and Hardware Needed:** Qty  
Mandolin Body..... 1

**To clean up the binding and fret ends:**

1. Use a fine machinist's file to make the binding even with the fretboard surface as shown in **Figure 17**. File up to the edge of the frets.

**Note:** File the binding at an angle so you do not damage the fretboard surface.

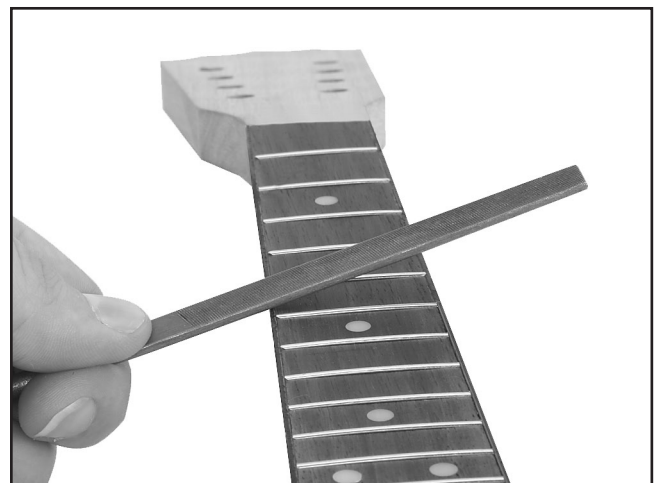

**Figure 17.** Filing fretboard binding.

2. Use a fine flat file to angle the metal fret ends, as shown in **Figure 18**.

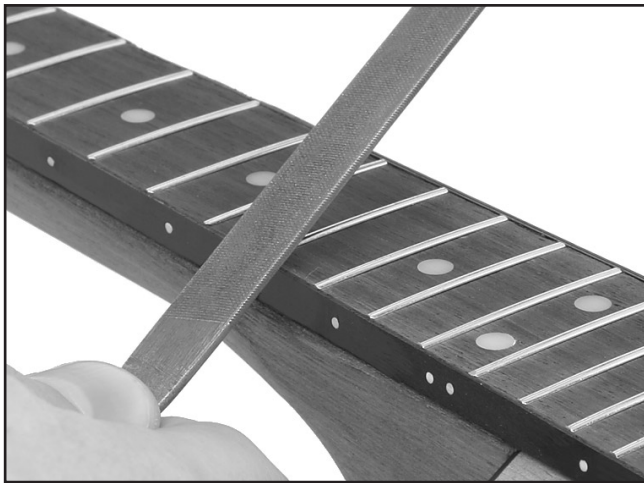

**Figure 18.** Filing fret ends.

**Note:** File enough of the fret ends so they are not sharp, as shown in **Figure 19**.



**Figure 19.** Example of correctly angled fret ends.

## Final Sanding

| Components and Hardware Needed: | Qty |
|---------------------------------|-----|
| Mandolin Body.....              | 1   |

### To prepare the mandolin for finishing:

1. Inspect the entire mandolin under bright lights and take note of any glue residue, dents, scratches, and areas needing further sanding.
2. Carefully scrape away any glue residue with a sharp chisel held perpendicular to the surface as shown in **Figure 20**.

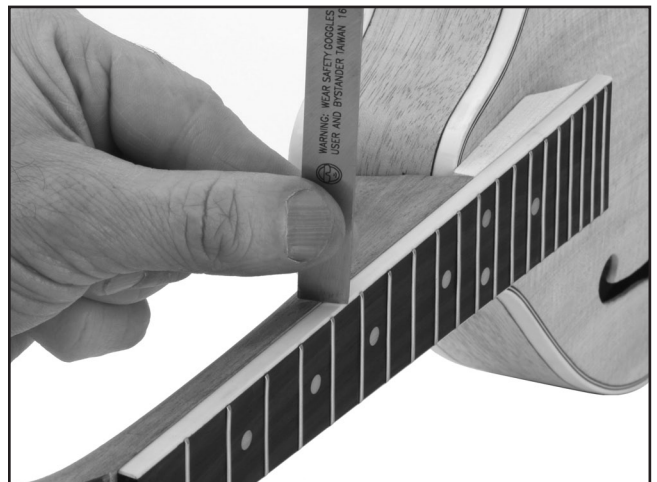

**Figure 20.** Example of removing glue residue.

3. **Wear a NIOSH-approved respirator and ANSI-approved safety glasses during the next step to protect against dust!**
4. Use #220 grit sandpaper to smooth any flaws found when inspecting the mandolin.
5. Final sand the entire mandolin, except the fretboard, with #320 grit sandpaper.



# Finishing

Finishing supplies are not included with this mandolin kit. Finishing options include stains, lacquers, varnishes and oil finishes. All can be applied by spray or brush. Finish materials and books on finishing instruments can be ordered through Grizzly Industrial or numerous luthier supply catalogs.

| Components and Hardware Needed: | Qty |
|---------------------------------|-----|
| Mandolin Body.....              | 1   |

## To finish the mandolin:

1. Mask off the surface of the fretboard. Carefully press all the masking tape edges securely to the fretboard. The finish coat should not be allowed to seep under edges, or flood-corners, and places where the frets meet the fingerboard.
2. Form a piece of wire into a U shaped hanger with hooks on both ends.
3. Thread the hooks through the upper pegholes and hang the instrument in the finish room.

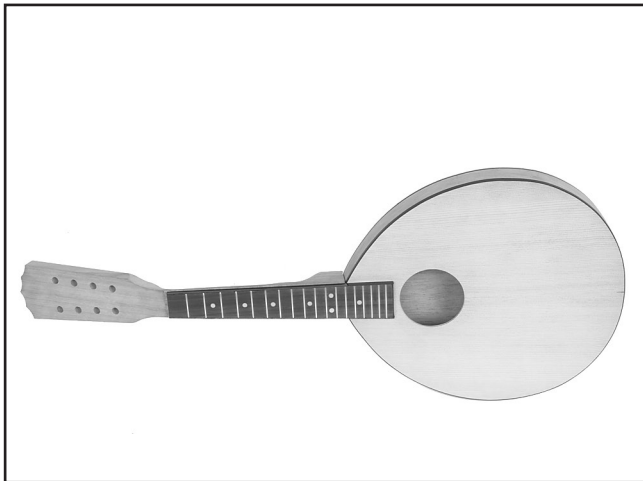

Figure 21. Instrument ready to be finished.

|  |  |
|--|--|
|  | <b>!WARNING</b><br>Most finishes are hazardous to your health. Wear a NIOSH/OSHA approved respirator with particulate and gas/vapor filters, safety glasses, rubber gloves, and work in a well ventilated area when finishing. |
|--|--|

4. Apply several thin coats of the finish (following the manufacturer's instructions). Multiple thin coats usually produce a better quality finish than one heavy coat.
5. Hang the instrument in a dust free area to dry.
6. When finishing is complete, remove the masking tape from the fretboard.
7. Carefully scrape any excess finish off the fretboard with a razor blade.

## Painting/Finishing Tips

Dust particles suspended in the air will settle on wet finishes, causing less than satisfactory results. To avoid this problem:

- Leave the finishing room undisturbed for 24 hours prior to applying the finish.
- Avoid making unnecessary movements upon entering the finish room.
- Apply the finish to the desired mandolin parts and immediately leave the finish room.
- DO NOT return to the room until the specified drying time has elapsed.



# Nut

The nut holds the peghead end of the strings the correct distance above the frets. It is not necessary to cut the string notches in the nut.

| Components and Hardware Needed: | Qty |
|---------------------------------|-----|
| Mandolin Body.....              | 1   |
| Nut .....                       | 1   |

## To install the nut:

1. Use a chisel to carefully scrape all of the finish out of the nut slot (**Figure 22**). DO NOT remove any wood from the nut slot.

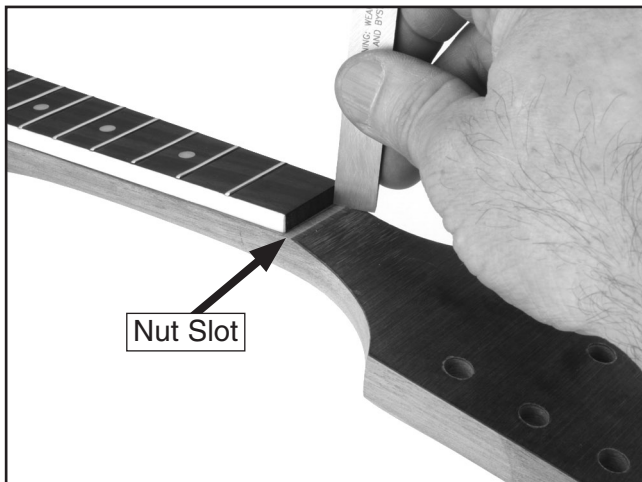

**Figure 22.** Example of cleaning out the nut slot.

2. Spread a thin layer of glue in the nut slot and on the end of the fretboard.
3. Place the nut in the nut slot and hold it in place with rubber strips or clamps until the glue dries.

**Note:** Use wood blocks and pads between the clamps and the neck to protect the instrument.

4. Wipe away excess glue before it sets, then allow the glue to dry for 24 hours.

# Tailpiece

The tailpiece holds and separates the ends of the strings.

| Components and Hardware Needed:       | Qty |
|---------------------------------------|-----|
| Mandolin Body.....                    | 1   |
| Tailpiece .....                       | 1   |
| #1 x 3/8" Stainless Steel Screws..... | 2   |
| #3 x 3/4" Stainless Steel Screw.....  | 1   |
| Endpin .....                          | 1   |

## To install the tailpiece:

1. Place the tailpiece on the edge of the soundboard and align the screw holes with the marks made earlier.
2. Secure the tailpiece to the mandolin with two #1 x 3/8" screws as shown in **Figure 23**.

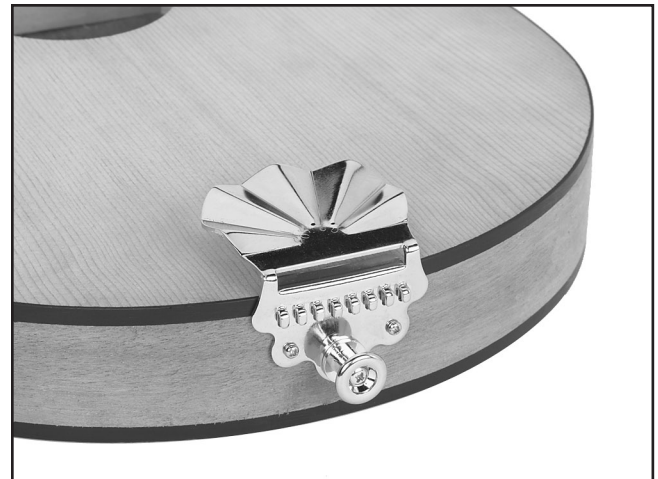

**Figure 23.** Tailpiece components.

3. Insert a #3 x 3/4" screw through the endpin (strap button).
4. Screw the endpin into the center hole of the tailpiece.





# Tuning Machines

| Components and Hardware Needed:       | Qty |
|---------------------------------------|-----|
| Mandolin Body.....                    | 1   |
| Tuning Machines .....                 | 2   |
| Bushings.....                         | 8   |
| #1 x 3/8" Stainless Steel Screws..... | 10  |

## To install the tuning machines:

1. Place the eight bushings in the pegholes as shown in **Figure 24**.

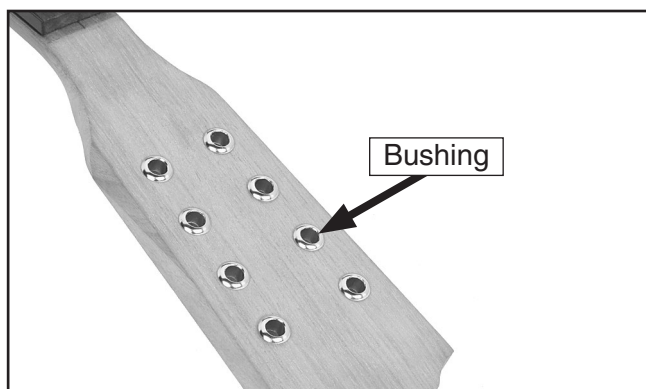

**Figure 24.** Peghead bushings.

2. Use a rubber dead blow hammer or a wood block to seat the bushings so the bushing flanges are flush with the peghead surface.
3. Turn the mandolin over and insert the tuning machines into the back of the pegholes.
4. Attach both tuning machines to the peghead with the #1 x 3/8" screws (**Figure 25**).

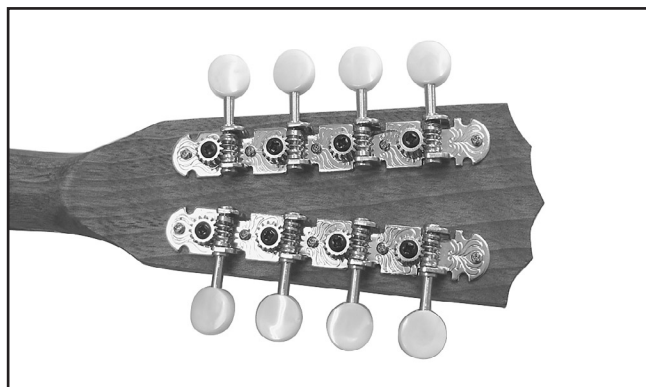

**Figure 25.** Tuning machines installed in the peghead.

# Fitting Bridge

| Components and Hardware Needed: | Qty |
|---------------------------------|-----|
| Mandolin Body.....              | 1   |
| Bridge .....                    | 1   |

This mandolin has a scale of 350mm, which means that the bridge will be placed 350mm (13.8") from the nut. Mandolin bridges are not glued into place, but are held in place with the string pressure, so final placement of the bridge occurs when the strings are tuned.

## To fit the bridge to the soundboard:

1. Place the bridge on a piece of sandpaper, grit side up, 350mm from the nut as shown in **Figure 26**.

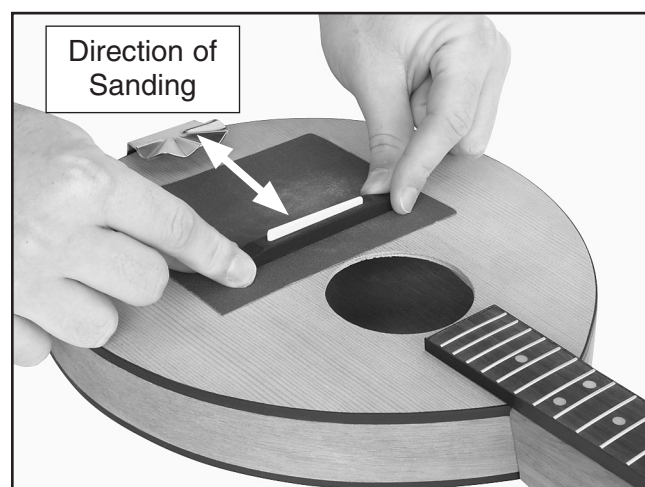

**Figure 26.** Fitting the bridge to the soundboard.

2. Hold the sandpaper firmly (to avoid marring the finish), and move the bridge back and forth between the sound hole and the tail-piece.
3. Remove the sandpaper and place the bridge on the soundboard. Look for gaps between the bridge and the soundboard. Repeat **Step 2** until there are no gaps.

# Placing Bridge

| Components and Hardware Needed: | Qty |
|---------------------------------|-----|
| Mandolin Body.....              | 1   |
| Bridge .....                    | 1   |

## To place the bridge:

1. Use a narrow file to make slots in the bridge. Angle the slots toward the tailpiece. See **Figure 27** for an example of string spacing on the bridge.

**Note:** Make the bridge slots the same depth as the nut slots. If you make the slots too deep, it will be harder to make adjustments.

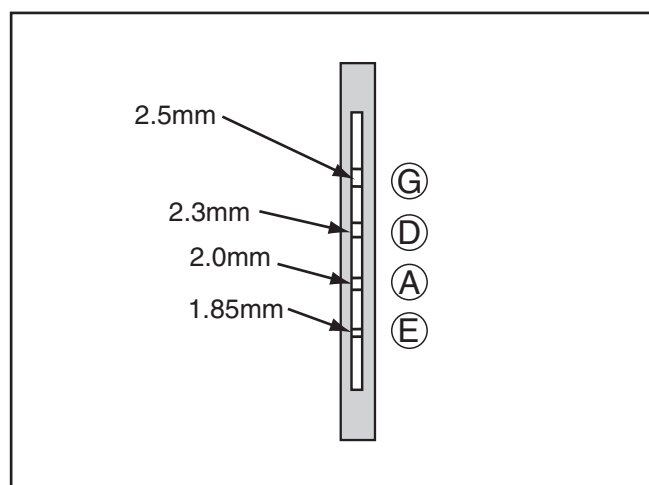

**Figure 27.** String slot example.

2. Lay the bridge flat on the mandolin so the taller side points toward the top of the body.
3. Follow the **Winding Strings** instructions on **Page 17**.
4. Slide the strings into their slots and tune.

5. Make sure that the bridge is located 350mm (13.8") from the nut and 175mm (6.89") from the 12th fret. (See **Figure 28**).



**Figure 28.** Bridge placement.

6. Set the position of the bridge by lightly touching the 1st string directly above the twelfth fret and pluck the string to play a harmonic note.
7. Now pluck the string while holding it against the twelfth fret. If this note is sharper than the note played in **Step 6**, move the bridge toward the tailpiece. If this note is flat in comparison, move the bridge toward the neck.

**Note:** This can also be done with an electronic tuner by tuning the harmonic note to be exactly in tune and then adjusting the bridge until the note played in **Step 7** is also in tune.



# Winding Strings

| Components and Hardware Needed: | Qty |
|---------------------------------|-----|
| Mandolin Body.....              | 1   |
| Strings .....                   | 8   |
| Bridge .....                    | 1   |

## To install the mandolin strings:

1. Bend the looped end of the strings and place them over the hooks on the tailpiece as shown in **Figure 29**. Work from the thinnest string (E string-treble) to the thickest (G string-bass).

**Tip:** Try bending the loops over the end of a sharpened pencil. You will have more control than with your fingers.

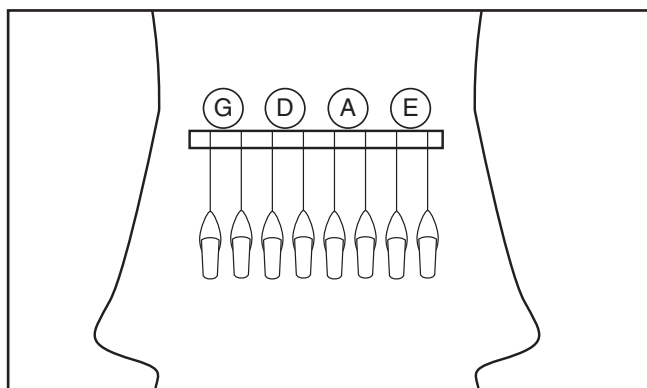

**Figure 29.** String placement.

2. Route the strings through the tailpiece, over the bridge, and into the inside of the tuning posts.

**Note:** Allow enough string slack for 2-3 complete winds around the tuning peg.

3. Turn the knobs to tighten the strings.

# String Height

Correct string height is crucial to prevent fret buzz and maximize playability. The string height is measured from the top face of the fret to the bottom of the string (**Figure 30**).

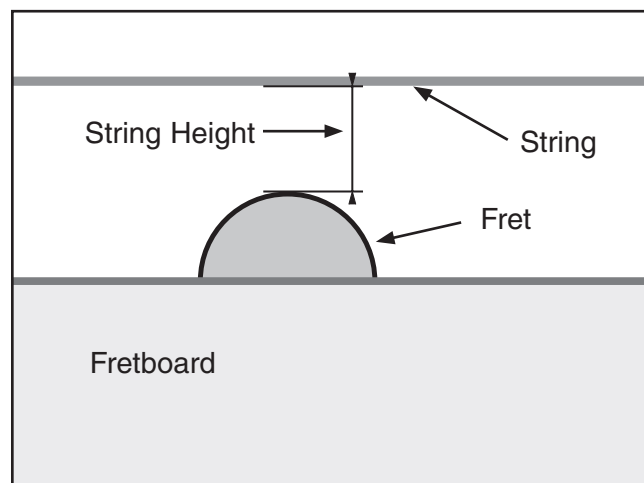

**Figure 30.** String height measurement.

Measurements are taken at the following locations along the first and eight strings.

- 1st fret
- 12th fret

## To check the string height at the first fret:

1. Measure the string height at the first fret. The first string measurement should be  $\frac{1}{64}$ " , the 8th string should be  $\frac{1}{64}$ "- $\frac{1}{32}$ ".

—If the string heights are correct (**Figure 31**), measure the string heights at the 12th fret.

—If the string heights are incorrect at the 1st fret, this is an indication that the string nut grooves must either be deeper or shallower.



# Tuning

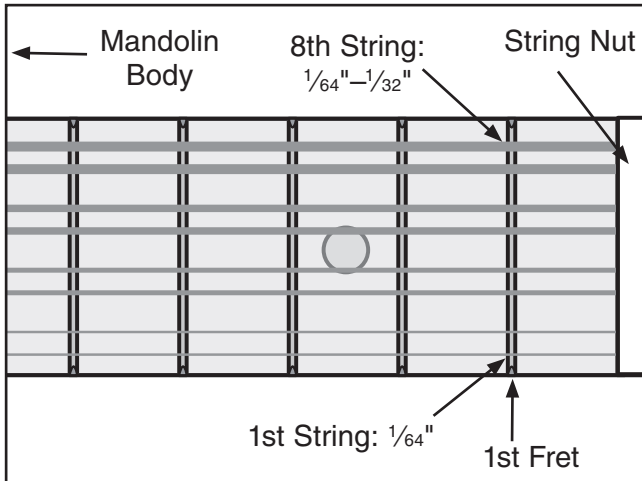

**Figure 31.** Correct 1st fret string heights.

## To check the string height at the 12th fret:

1. Measure the string height at the 12th fret (**Figure 32**). The first string measurement should be  $\frac{3}{32} - \frac{7}{64}$ "; the 8th string should be  $\frac{7}{64} - \frac{9}{64}$ ".

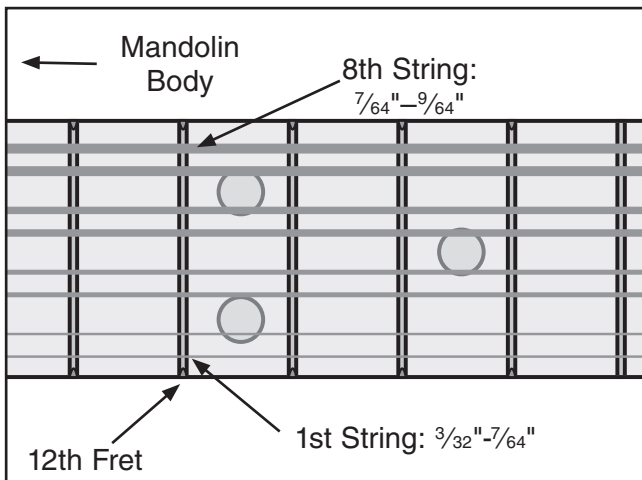
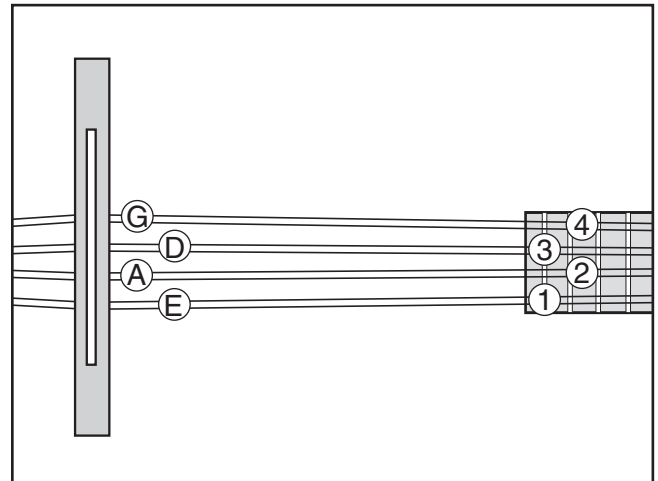

**Figure 32.** Correct 12th fret string heights.

—If the string height is correct, then continue to the next sub-section.

—If the string height is incorrect at the 12th fret, the bridge slots must be deeper or shallower.

Correct tuning is the most important aspect of performance for a mandolin. If the mandolin is not in tune with itself, or with other instruments in an ensemble, the resulting music will not please the ear. The standard mandolin tuning notes are shown in **Figure 33**.



**Figure 33.** Standard tuning notes.

## Important issues to consider when tuning a mandolin:

- Get into the habit of tuning the mandolin every time you play it.
- Always tune the strings “up.” The final tuned tension of each string should be reached by tightening the string, not by loosening it. If the string is tensioned too far, release the tension and tune “up” again.
- The easiest way to tune a mandolin is using an electronic tuner such as the Grizzly H3097 Chromatic Tuner shown on **Page 19**.



# SECTION 6: REFERENCE INFO

## Accessories

**G7984—Face Shield**

**H1298—Dust Sealed Safety Glasses**

**H1300—UV Blocking, Clear Safety Glasses**

**H2347—Uvex® Spitfire Safety Glasses**

**H0736—Shop Fox® Safety Glasses**

Safety Glasses are essential to every shop. If you already have a pair, buy extras for visitors or employees. You can't be too careful when it comes to shop safety!



**Figure 34.** Our most popular safety glasses.

**H3097—Chromatic Tuner**

An absolute must for any guitar player, this tuner allows you to tune your acoustic or electric guitar dead on. Includes 9V battery.



**Figure 35.** Model H3097 Chromatic Tuner.

**H1302—Standard Earmuffs**

**H4979—Deluxe Twin Cup Hearing Protector**

**H4977—Work-Tunes Radio Headset Earmuffs**

Protect yourself comfortably with a pair of cushioned earmuffs. Especially important if you or employees operate for hours at a time.



**Figure 36.** Our most popular earmuffs.

**H5097—Constructing a Bluegrass Mandolin**

This beautifully detailed manual gives clear, step by step directions from raw materials to a magnificently finished mandolin through the use of simply stated texts, photos and templates. Spiral bound and includes 19 full-sized blueprints covering each phase of construction. 56 pages.

**H5332—Titebond Original Wood Glue, 16 Oz.**

The industry standard for luthiers.

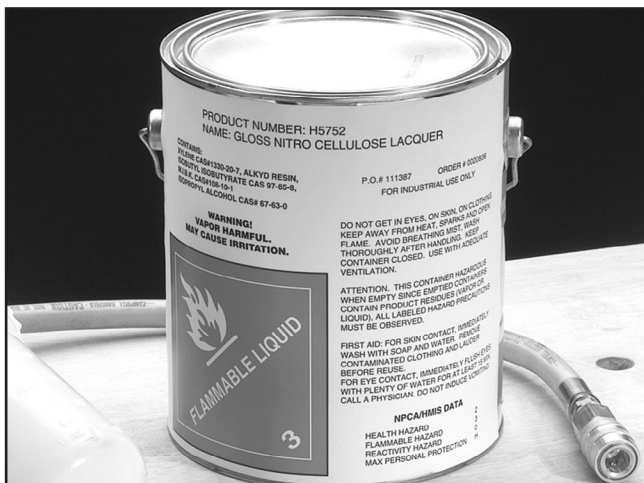

**Figure 37.** Model H5332 Titebond Wood Glue.

**Call 1-800-523-4777 To Order**

- H5750—Vinyl Washcoat/Sealer, 1Qt
- H5751—Nitrocellulose Lacquer, Gloss, 1 Qt
- H5752—Nitrocellulose Lacquer, Gloss, 1 Gal
- H5753—Nitrocellulose Lacquer, Satin, 1 Qt
- H5754—Nitrocellulose Lacquer, Satin, 1 Gal
- H5755—Retarder for Lacquer, 1 Qt
- H5756—Natural Filler, 1 Pint
- H5757—Mahogany Filler, 1 Pint
- H5759—Filler Reducer, 1Qt

McFadden's nitrocellulose lacquer is the leading lacquer used by custom guitar builders. It sprays and buffs really well and is capable of giving you a finish that looks "wet."



**Figure 38.** Model H5750-59 McFadden's Lacquers and Fillers.

**G8979—6 Pc. Mini File Set**

For delicate work, this mini file set includes an assortment of oval, flat, half round, round, triangular and square files with comfortable handles.



**Figure 39.** Model G8979 mini file set.

- H2499—Small Half-Mask Respirator
- H3631—Medium Half-Mask Respirator
- H3632—Large Half-Mask Respirator
- H3633—Disposable Cartridge Filter Pair
- H3635—Disposable Cartridge Filter Pair

This lightweight elastomeric facepiece has cradle suspension, easy adjust headstraps and low profile for greater field of vision and compatibility with normal use of glasses or goggles. Purchase cartridges separately depending upon intended application.

Model H3633 protects against organic vapor, sulfur dioxide, hydrogen chloride and chlorine. Model H3635 protects against all particulate aerosols.



**Figure 40.** Half-mask respirator and disposable cartridge filters.

**Call 1-800-523-4777 To Order**



# WARRANTY AND RETURNS

---

Grizzly Industrial, Inc. warrants every product it sells for a period of **1 year** to the original purchaser from the date of purchase. This warranty does not apply to defects due directly or indirectly to misuse, abuse, negligence, accidents, repairs or alterations or lack of maintenance. This is Grizzly's sole written warranty and any and all warranties that may be implied by law, including any merchantability or fitness, for any particular purpose, are hereby limited to the duration of this written warranty. We do not warrant or represent that the merchandise complies with the provisions of any law or acts unless the manufacturer so warrants. In no event shall Grizzly's liability under this warranty exceed the purchase price paid for the product and any legal actions brought against Grizzly shall be tried in the State of Washington, County of Whatcom.

We shall in no event be liable for death, injuries to persons or property or for incidental, contingent, special, or consequential damages arising from the use of our products.

To take advantage of this warranty, contact us by mail or phone and give us all the details. We will then issue you a "Return Number," which must be clearly posted on the outside as well as the inside of the carton. We will not accept any item back without this number. Proof of purchase must accompany the merchandise.

The manufacturers reserve the right to change specifications at any time because they constantly strive to achieve better quality equipment. We make every effort to ensure that our products meet high quality and durability standards and we hope you never need to use this warranty.

Please feel free to write or call us if you have any questions about the machine or the manual.

Thank you again for your business and continued support. We hope to serve you again soon.









# WARRANTY CARD

Name \_\_\_\_\_  
 Street \_\_\_\_\_  
 City \_\_\_\_\_ State \_\_\_\_\_ Zip \_\_\_\_\_  
 Phone # \_\_\_\_\_ Email \_\_\_\_\_ Invoice # \_\_\_\_\_  
 Model # \_\_\_\_\_ Order # \_\_\_\_\_ Serial # \_\_\_\_\_

The following information is given on a voluntary basis. It will be used for marketing purposes to help us develop better products and services. **Of course, all information is strictly confidential.**

1. How did you learn about us?

Advertisement                       Friend                       Catalog  
 Card Deck                               Website                       Other:

2. Which of the following magazines do you subscribe to?

|   |  |   |
|---|--|---|
| <input type="checkbox"/> Cabinet Maker          | <input type="checkbox"/> Popular Mechanics   | <input type="checkbox"/> Today's Homeowner    |
| <input type="checkbox"/> Family Handyman        | <input type="checkbox"/> Popular Science     | <input type="checkbox"/> Wood                 |
| <input type="checkbox"/> Hand Loader            | <input type="checkbox"/> Popular Woodworking | <input type="checkbox"/> Wooden Boat          |
| <input type="checkbox"/> Handy                  | <input type="checkbox"/> Practical Homeowner | <input type="checkbox"/> Woodshop News        |
| <input type="checkbox"/> Home Shop Machinist    | <input type="checkbox"/> Precision Shooter   | <input type="checkbox"/> Woodsmith            |
| <input type="checkbox"/> Journal of Light Cont. | <input type="checkbox"/> Projects in Metal   | <input type="checkbox"/> Woodwork             |
| <input type="checkbox"/> Live Steam             | <input type="checkbox"/> RC Modeler          | <input type="checkbox"/> Woodworker West      |
| <input type="checkbox"/> Model Airplane News    | <input type="checkbox"/> Rifle               | <input type="checkbox"/> Woodworker's Journal |
| <input type="checkbox"/> Modeltec               | <input type="checkbox"/> Shop Notes          | <input type="checkbox"/> Other:               |
| <input type="checkbox"/> Old House Journal      | <input type="checkbox"/> Shotgun News        |   |

3. What is your annual household income?

\$20,000-\$29,000                       \$30,000-\$39,000                       \$40,000-\$49,000  
 \$50,000-\$59,000                       \$60,000-\$69,000                       \$70,000+

4. What is your age group?

20-29                                       30-39                                       40-49  
 50-59                                       60-69                                       70+

5. How long have you been a woodworker/metalworker?

0-2 Years                       2-8 Years                       8-20 Years                       20+ Years

6. How many of your machines or tools are Grizzly?

0-2                       3-5                       6-9                       10+

7. Do you think your machine represents a good value?     Yes                       No

8. Would you recommend Grizzly Industrial to a friend?     Yes                       No

9. Would you allow us to use your name as a reference for Grizzly customers in your area?  
**Note: We never use names more than 3 times.**                       Yes                       No

10. Comments: \_\_\_\_\_  
 \_\_\_\_\_  
 \_\_\_\_\_

CUT ALONG DOTTED LINE

FOLD ALONG DOTTED LINE

\_\_\_\_\_

\_\_\_\_\_

\_\_\_\_\_



Place  
Stamp  
Here



GRIZZLY INDUSTRIAL, INC.  
P.O. BOX 2069  
BELLINGHAM, WA 98227-2069



FOLD ALONG DOTTED LINE

Send a Grizzly Catalog to a friend:

|                                  |
|----------------------------------|
| Name _____                       |
| Street _____                     |
| City _____ State _____ Zip _____ |

TAPE ALONG EDGES--PLEASE DO NOT STAPLE



# *grizzly.com*

**TOOL WEBSITE**

Buy Direct and Save with Grizzly® – Trusted, Proven and a Great Value!

*Visit Our Website Today And Discover  
Why Grizzly® Is The Industry Leader!*

- SECURE ORDERING
- ORDERS SHIPPED WITHIN 24 HOURS
- E-MAIL RESPONSE WITHIN ONE HOUR

-OR-

Call Today For A **FREE**  
Full Color Catalog

**1-800-523-4777**



## Free Manuals Download Website

<http://myh66.com>

<http://usermanuals.us>

<http://www.somanuals.com>

<http://www.4manuals.cc>

<http://www.manual-lib.com>

<http://www.404manual.com>

<http://www.luxmanual.com>

<http://aubethermostatmanual.com>

Golf course search by state

<http://golfingnear.com>

Email search by domain

<http://emailbydomain.com>

Auto manuals search

<http://auto.somanuals.com>

TV manuals search

<http://tv.somanuals.com>