

Grizzly *Industrial, Inc.*®

MODEL H8217

3/8" REVERSIBLE ANGLE DRILL

0-1500 RPM

INSTRUCTION MANUAL



COPYRIGHT © AUGUST, 2007 BY GRIZZLY INDUSTRIAL, INC.
**WARNING: NO PORTION OF THIS MANUAL MAY BE REPRODUCED IN ANY SHAPE
OR FORM WITHOUT THE WRITTEN APPROVAL OF GRIZZLY INDUSTRIAL, INC.**
#JM9331 PRINTED IN CHINA



WARNING!

This manual provides critical safety instructions on the proper setup, operation, maintenance and service of this machine/equipment.

Failure to read, understand and follow the instructions given in this manual may result in serious personal injury, including amputation, electrocution or death.

The owner of this machine/equipment is solely responsible for its safe use. This responsibility includes but is not limited to proper installation in a safe environment, personnel training and usage authorization, proper inspection and maintenance, manual availability and comprehension, application of safety devices, blade/cutter integrity, and the usage of personal protective equipment.

The manufacturer will not be held liable for injury or property damage from negligence, improper training, machine modifications or misuse.



WARNING!

Some dust created by power sanding, sawing, grinding, drilling, and other construction activities contains chemicals known to the State of California to cause cancer, birth defects or other reproductive harm. Some examples of these chemicals are:

- **Lead from lead-based paints.**
- **Crystalline silica from bricks, cement and other masonry products.**
- **Arsenic and chromium from chemically-treated lumber.**

Your risk from these exposures varies, depending on how often you do this type of work. To reduce your exposure to these chemicals: Work in a well ventilated area, and work with approved safety equipment, such as those dust masks that are specially designed to filter out microscopic particles.

SAFETY

WARNING

For Your Own Safety Read Instruction Manual Before Operating This Equipment

The purpose of safety symbols is to attract your attention to possible hazardous conditions. This manual uses a series of symbols and signal words which are intended to convey the level of importance of the safety messages. The progression of symbols is described below. Remember that safety messages by themselves do not eliminate danger and are not a substitute for proper accident prevention measures.



Indicates an imminently hazardous situation which, if not avoided, **WILL** result in death or serious injury.



Indicates a potentially hazardous situation which, if not avoided, **COULD** result in death or serious injury.



Indicates a potentially hazardous situation which, if not avoided, **MAY** result in minor or moderate injury. It may also be used to alert against unsafe practices.

NOTICE

This symbol is used to alert the user to useful information about proper operation of the equipment.

WARNING

Safety Instructions for Pneumatic Tools

- 1. READ THIS MANUAL.** This tool may cause personal injury if used incorrectly. This manual contains proper safety and operating instructions that must be followed to reduce this risk.
- 2. WEAR EYE PROTECTION.** This tool may throw small fragments during operation, which may cause serious eye injury. Always wear ANSI approved safety glasses or face shield to reduce your risk from this hazard.
- 3. WEAR A RESPIRATOR.** This tool may produce fine dust during operation, which can cause respiratory injury if inhaled. Always wear a respirator NIOSH approved for the type of material being processed.
- 4. WEAR HEARING PROTECTION.** Operating this tool for prolonged time periods may damage your hearing. Your risk depends on length and frequency of use. To reduce your risk of this hazard, wear hearing protection.
- 5. MAINTAIN SAFETY GUARDS.** Your tool may be equipped with safety guards or other structural components designed to reduce the risk of injury during operation. Never modify or operate this tool with any guards or components removed or damaged.
- 6. KEEP CHILDREN AWAY.** Prevent children from injury by keeping them away from this tool. Disconnect and lock the tool away when not in use.

7. **AVOID ENTANGLEMENTS.** Do not wear loose clothing, gloves, neckties, rings, bracelets, or other jewelry, which may get caught in moving parts, when operating this tool. Wear a protective hair covering to contain long hair.
8. **USE CORRECT AIR PRESSURE.** Exceeding the maximum PSI rating of this tool may cause unpredictable operation or bursting.
9. **DISCONNECT AIR PRESSURE** before servicing, changing accessories, or moving to another location. Never leave this tool unattended when connected to air.
10. **SECURE TOOLING.** Always verify tooling is secure before operation.
11. **SHARP SURFACES.** DO NOT place hands near the tooling surfaces when in operation.
12. **REMOVE ADJUSTING KEYS AND WRENCHES AFTER USE.** These tools become dangerous projectiles if left on the tool when it is started.
13. **AVOID FLAMMABLES.** Do not use this tool around any flammables that may be ignited by sparks.
14. **SECURE WORK.** Use clamps or a vise to hold work when practical. It is safer than using your hand and frees both hands to operate tool.
15. **MAINTAIN TOOLS WITH CARE.** Keep tools lubricated and clean for best and safest performance. Follow instructions for lubricating and changing accessories.
16. **DO NOT FORCE TOOL.** It will do the job better and safer at the rate for which it was designed.
17. **CHECK FOR DAMAGED PARTS BEFORE USING.** Check for binding and alignment of parts, broken parts, part mounting, loose bolts, and any other conditions that may affect operation. Repair or replace damaged parts before operating.
18. **USE GOOD LIGHTING.** Keep work area well lighted. Dark work areas increase risk of accidental injury.
19. **AVOID UNINTENTIONAL OPERATION.** Always disconnect air when not in use, and do not carry tool with hand on trigger.
20. **USE THE RECOMMENDED ACCESSORIES.** Consult owner's manual for recommended accessories. Using improper accessories may increase the risk of injury.
21. **NEVER ALLOW UNTRAINED USERS TO USE THIS TOOL WHILE UNSUPERVISED.**
22. **IF YOU ARE UNSURE OF THE INTENDED OPERATION, STOP USING TOOL.** Seek formal training or research books or magazines that specialize in pneumatic tools.
23. **BE AWARE OF HOSE LOCATION.** Hoses can easily become a tripping hazard when laid across the floor in a disorganized fashion.
24. **DO NOT USE UNDER THE INFLUENCE OF DRUGS OR ALCOHOL, OR WHEN TIRED.**

CAUTION

No list of safety guidelines is complete, because every work environment is different. Always consider safety first and use common sense. Failure to use this tool with caution and respect could result in serious personal injury.

INTRODUCTION

Foreword

The specifications, details, and photographs in this manual represent the Model H8217 as supplied when the manual was prepared. However, owing to Grizzly's policy of continuous improvement, changes may be made at any time with no obligation on the part of Grizzly.

If you have any comments regarding this manual, please write to us at the following address:

Grizzly Industrial, Inc.
C/O Technical Documentation
P.O. Box 2069
Bellingham, WA 98227-2069
E-Mail: manuals@grizzly.com

Most importantly, we stand behind our tools. If you have any service questions or parts requests, please call or write us at the location listed below.

Grizzly Industrial, Inc.
1203 Lycoming Mall Circle
Muncy, PA 17756
Phone: (570) 546-9663
Fax: (800) 438-5901
E-Mail: techsupport@grizzly.com
Web Site: <http://www.grizzly.com>

Specifications

Collet Size..... $\frac{3}{8}$ "
No Load Speed.....0-1,500 RPM
Air Consumption.....6 CFM
Air Inlet..... $\frac{1}{4}$ "
Required PSI.....90 PSI
Maximum Sound Level.....102 dB

Inventory

H8217 Inventory	Qty
A. Bottle of Light Oil	1
B. Air Drill	1
C. $\frac{1}{4}$ " NPT Quick Connect Fitting (male) 1	
D. Chuck Key.....	1

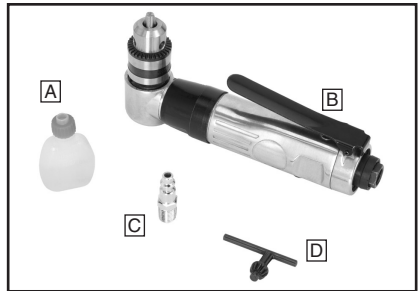
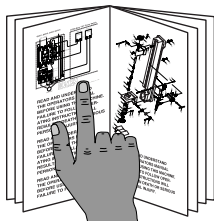

Figure 1. Model H8217 Inventory.

OPERATIONS

!WARNING



Read the manual before operation. Become familiar with this tool, its safety instructions, and its operation before beginning any work. Serious personal injury may result if safety or operational information is not understood or followed.

!WARNING

Like all tools there is potential danger when operating this tool. Accidents are frequently caused by lack of familiarity or failure to pay attention. If normal safety precautions are overlooked or ignored, serious personal injury may occur.

Installing Bits

The Model H8217 uses drill bits with a 0 to $\frac{3}{8}$ " diameter shaft. See the Grizzly catalog or www.grizzly.com for a complete listing of available bits and accessories.

To install a bit:

1. DISCONNECT THE DRILL FROM THE AIR SUPPLY!
2. Insert the chuck key into to chuck, as shown in **Figure 2**. Turn the key to loosen the jaws enough to allow the bit shaft to fit inside the chuck.

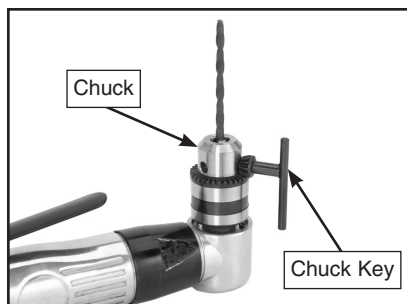

Figure 2. Installing a bit.

3. Insert the drill bit at least $\frac{3}{8}$ " straight into the chuck.
4. Tighten the chuck with the chuck key by turning it clockwise. Verify that the tooling bit is secure and will not pull out.

Note: All three jaws inside the chuck must grip the bit shaft evenly or the bit may come loose when the drill is turned on.

Using the Angle Drill

1. Attach the $\frac{1}{4}$ " NPT male quick connect fitting to the air inlet plug.
2. Attach the drill to an air supply set at 90 PSI.
3. Hold the drill securely.

- Using the trigger to control RPM, ease the working end of the bit against the workpiece with a light, but steady, pressure.
- Reverse the drill direction by pushing the reverse valve into the body, then rotate to lock into position (**Figure 3**).

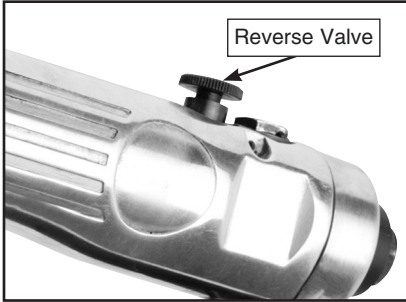

Figure 3. Location of reverse valve.

⚠ CAUTION
 To avoid accidental starting, disconnect the drill from the air supply when it is not in use.

Daily Maintenance

Drop 2-6 drops of air tool oil directly into the air fitting before using the drill. In addition, drip 2-6 drops of oil directly into the ball oiler by depressing the oil ball located in the angle housing, shown in **Figure 4**.



Figure 4. Ball oiler location.

⚠ WARNING	
	LUNG/EAR INJURY HAZARD! Wear protective equipment when using this tool.
	ACCIDENTAL START HAZARD! Disconnect before service or tool changes.
	AIR PRESSURE HAZARD! Never exceed 120 PSI.
	EYE INJURY HAZARD! Wear protective equipment when using this tool.

For improved lubrication to extend the life span of your drill, we recommend using an in-line filter, lubricator, and regulator, as shown in **Figure 5**.

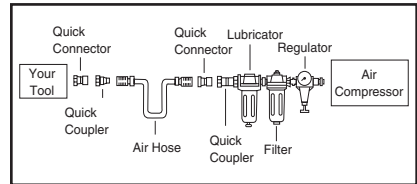
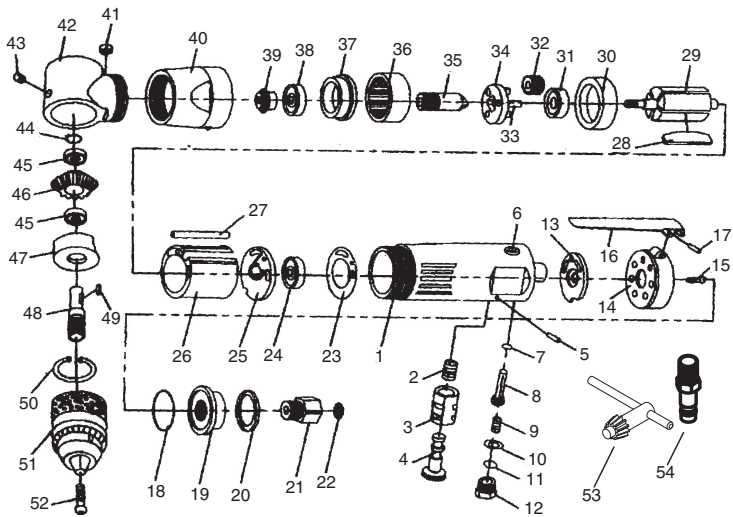

Figure 5. Installed filter lubricator regulator.

These procedures should be done after each use:

- Wipe the motor housing and tool bits with a dry cloth, or blow off the dust and debris with compressed air.
- Check for damage to tooling, hoses, housing or other accessories.
- Relubricate with 2-6 drops of oil into the air inlet fitting before storage.

H8217 PARTS LIST



REF PART #	DESCRIPTION
1	PH8217001 HOUSING
2	PH8217002 COMPRESSION SPRING
3	PH8217003 REVERSE VALVE HOUSING
4	PH8217004 REVERSE VALVE
5	PH8217005 ROLL PIN 2.5 X 20
6	PH8217006 VALVE HOUSING
7	POR004 O-RING 4 X 2
8	PH8217008 VALVE PIN
9	PH8217009 COMPRESSION SPRING
10	PH8217010 SPECIAL WASHER
11	PORP008 O-RING 7.8 X 1.9 P8
12	PH8217012 PLUG
13	PH8217013 SEAL WASHER
14	PH8217014 END PLATE
15	PS50M PHLP HD SCR M3-.5 X 12
16	PH8217016 TRIGGER
17	PRP43M ROLL PIN 3 X 22
18	PORS030 O-RING 29.5 X 2.0 S30
19	PH8217019 EXHAUST CAP
20	PH8217020 CLIP RING
21	PH8217021 AIR INLET PLUG
22	PH8217022 AIR FILTER
23	PH8217023 SEAL WASHER
24	P626 BALL BEARING 626ZZ
25	PH8217025 CYLINDER CAP
26	PH8217026 CYLINDER
27	PH8217027 CYLINDER PIN

REF PART #	DESCRIPTION
28	PH8217028 ROTOR BLADE
29	PH8217029 ROTOR
30	PH8217030 COVER BOARD
31	P608 BALL BEARING 608ZZ
32	PH8217032 GEAR WHEEL
33	PH8217033 WHEEL PIN
34	PH8217034 WHEEL SEAT
35	PH8217035 WHEEL SHAFT
36	PH8217036 GEAR WHEEL
37	PH8217037 SHOULDER WASHER
38	P6001 BALL BEARING 6001ZZ
39	PH8217039 ARC GEAR WHEEL
40	PH8217040 LOCK RING
41	PH8217041 BALL OILER
42	PH8217042 ANGLE HOUSING
43	PSS79M SET SCREW M4-.7 X 6
44	PR04M EXT RETAINING RING 6MM
45	P626 BALL BEARING 626ZZ
46	PH8217046 ARC GEAR WHEEL
47	PH8217047 BEARING SEAT
48	PH8217048 BEARING SHAFT
49	PH8217049 SEMICIRCULAR KEY
50	PR29M INT RETAINING RING 32MM
51	PH8217051 CHUCK
52	PS40 PHLP HD SCR 10-32 X 3/4
53	PH8217053 CHUCK KEY
54	PH8217054 1/4" NPT MALE AIR FITTING

Free Manuals Download Website

<http://myh66.com>

<http://usermanuals.us>

<http://www.somanuals.com>

<http://www.4manuals.cc>

<http://www.manual-lib.com>

<http://www.404manual.com>

<http://www.luxmanual.com>

<http://aubethermostatmanual.com>

Golf course search by state

<http://golfingnear.com>

Email search by domain

<http://emailbydomain.com>

Auto manuals search

<http://auto.somanuals.com>

TV manuals search

<http://tv.somanuals.com>