

# *Grizzly* **Industrial, Inc.**®

## **MODEL G0694 20" X 43" HEAVY-DUTY VARIABLE SPEED WOOD LATHE OWNER'S MANUAL**



COPYRIGHT © JULY, 2009 BY GRIZZLY INDUSTRIAL, INC.  
**WARNING: NO PORTION OF THIS MANUAL MAY BE REPRODUCED IN ANY SHAPE  
OR FORM WITHOUT THE WRITTEN APPROVAL OF GRIZZLY INDUSTRIAL, INC.**  
(FOR MODELS MANUFACTURED SINCE 1/09) #TRCRBLTSJB11817 PRINTED IN TAIWAN

 **WARNING!**

**This manual provides critical safety instructions on the proper setup, operation, maintenance and service of this machine/equipment.**

**Failure to read, understand and follow the instructions given in this manual may result in serious personal injury, including amputation, electrocution or death.**

**The owner of this machine/equipment is solely responsible for its safe use. This responsibility includes but is not limited to proper installation in a safe environment, personnel training and usage authorization, proper inspection and maintenance, manual availability and comprehension, application of safety devices, blade/cutter integrity, and the usage of personal protective equipment.**

**The manufacturer will not be held liable for injury or property damage from negligence, improper training, machine modifications or misuse.**

 **WARNING!**

**Some dust created by power sanding, sawing, grinding, drilling, and other construction activities contains chemicals known to the State of California to cause cancer, birth defects or other reproductive harm. Some examples of these chemicals are:**

- **Lead from lead-based paints.**
- **Crystalline silica from bricks, cement and other masonry products.**
- **Arsenic and chromium from chemically-treated lumber.**

**Your risk from these exposures varies, depending on how often you do this type of work. To reduce your exposure to these chemicals: Work in a well ventilated area, and work with approved safety equipment, such as those dust masks that are specially designed to filter out microscopic particles.**

# Table of Contents

<b>INTRODUCTION .....</b>	<b>2</b>	<b>SECTION 5: ACCESSORIES .....</b>	<b>33</b>
Manual Accuracy .....	2	<b>SECTION 6: MAINTENANCE.....</b>	<b>35</b>
Contact Info.....	2	Schedule .....	35
Machine Description .....	2	Cleaning.....	35
Identification.....	3	Lathe Bed.....	35
Machine Data Sheet .....	4	Spindle Bearing Lubrication.....	35
<b>SECTION 1: SAFETY .....</b>	<b>6</b>	General Lubrication.....	37
Safety Instructions for Machinery .....	6	<b>SECTION 7: SERVICE .....</b>	<b>39</b>
Additional Safety for Wood Lathes .....	8	Troubleshooting .....	39
<b>SECTION 2: CIRCUIT REQUIREMENTS .....</b>	<b>9</b>	Belt Adjustment.....	41
220V Single-Phase Operation .....	9	Changing Belt/Bearing Service.....	42
<b>SECTION 3: SETUP .....</b>	<b>10</b>	<b>SECTION 8: WIRING.....</b>	<b>47</b>
Needed for Setup.....	10	Wiring Safety Instructions .....	47
Unpacking .....	10	Wiring Diagram .....	48
Inventory .....	11	Electrical Components.....	49
Cleanup.....	12	<b>SECTION 9: PARTS .....</b>	<b>50</b>
Site Considerations.....	13	Lathe .....	50
Moving & Placing Lathe .....	14	Stand.....	52
Mounting to Shop Floor .....	15	Stand Parts List .....	53
Test Run .....	16	Labels & Cosmetics .....	54
<b>SECTION 4: OPERATIONS .....</b>	<b>18</b>	<b>WARRANTY AND RETURNS .....</b>	<b>57</b>
Basic Controls.....	18		
Operation Overview .....	19		
Stock Inspection & Requirements.....	19		
Tailstock.....	20		
Inboard Tool Rest .....	20		
Outboard Tool Rest .....	21		
Installing/Removing Headstock Center.....	22		
Installing/Removing Tailstock Center .....	23		
Installing Faceplate/Handwheel .....	24		
Adjusting Spindle Speeds.....	25		
Indexing .....	26		
Selecting Turning Tools .....	27		
Spindle Turning.....	28		
Faceplate Turning.....	30		
Outboard Turning.....	31		
Sanding/Finishing .....	32		


# INTRODUCTION

## Manual Accuracy

We are proud to offer this manual with your new machine! We've made every effort to be exact with the instructions, specifications, drawings, and photographs of the machine we used when writing this manual. However, sometimes errors do happen and we apologize for them.

Also, owing to our policy of continuous improvement, **your machine may not exactly match the manual**. If you find this to be the case, and the difference between the manual and machine leaves you in doubt, check our website for the latest manual update or call technical support for help.

Before calling, find the manufacture date of your machine by looking at the date stamped into the machine ID label (see below). This will help us determine if the manual version you received matches the manufacture date of your machine.

		MODEL GXXXX MACHINE NAME	
SPECIFICATIONS		▲ WARNING!	
Motor:		<b>Manufacture Date of Your Machine</b> ing this machine: operation. s and respirator. sted/setup and suit before starting.	
Specification:			
Specification:			
Specification:			
Weight:			
	Date	4. make sure the motor has stopped and disconnect power before adjustments, maintenance, or service.	
	Serial Number	5. DO NOT expose to rain or dampness.	
Manufactured for Grizzly in Taiwan		6. DO NOT modify this machine in any way.	
		7. DO NOT remove safety guards.	
		8. Never leave machine running unattended.	
		9. DO NOT operate under the influence of drugs or alcohol.	
		10. Maintain machine carefully to prevent accidents.	

For your convenience, we post all available manuals and manual updates for free on our website at [www.grizzly.com](http://www.grizzly.com). Any updates to your model of machine will be reflected in these documents as soon as they are complete.

## Contact Info

We stand behind our machines. If you have any service questions, parts requests or general questions about the machine, please call or write us at the location listed below.

Grizzly Industrial, Inc.  
1203 Lycoming Mall Circle  
Muncy, PA 17756  
Phone: (570) 546-9663  
Fax: (800) 438-5901  
E-Mail: [techsupport@grizzly.com](mailto:techsupport@grizzly.com)

If you have any comments regarding this manual, please write to us at the address below:

Grizzly Industrial, Inc.  
c/o Technical Documentation Manager  
P.O. Box 2069  
Bellingham, WA 98227-2069  
Email: [manuals@grizzly.com](mailto:manuals@grizzly.com)

## Machine Description

The G0694 20" x 43" Heavy-Duty Variable Speed Wood Lathe is designed to turn wood stock so the operator can remove material with a hand held cutting tool called a chisel.

The variable speed control allows for infinite spindle speed adjustment from 50–3,000 RPM and the digital readout provides a precise reading of the current spindle speed.

The outboard tool rest and double-sided spindle allows for the turning of workpieces with diameters larger than 20" on the outboard side of the lathe.



# Identification

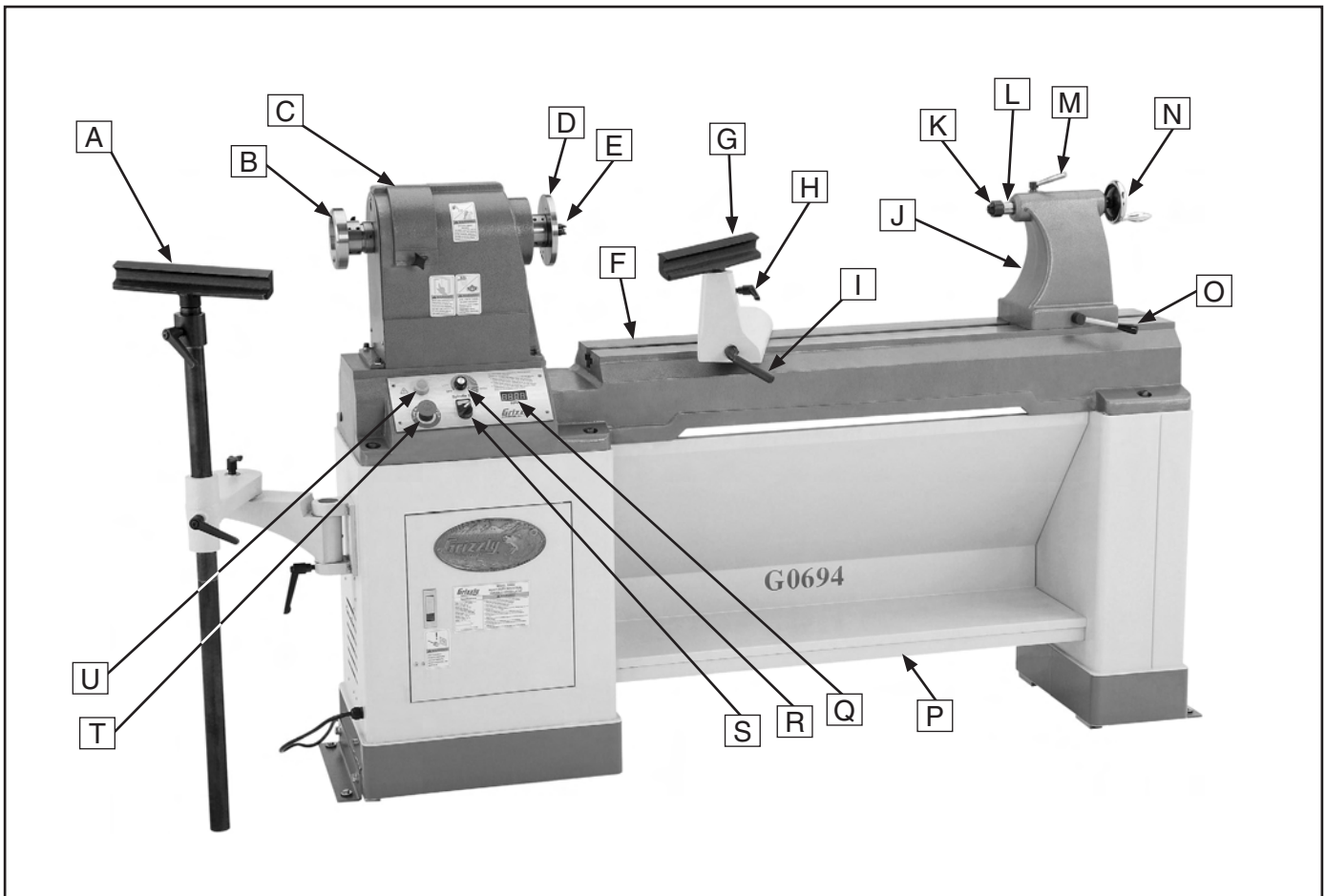
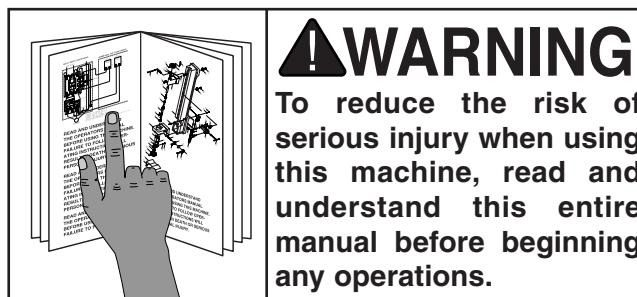


Figure 1. Identification.

- |                                     |                               |
|-------------------------------------|-------------------------------|
| A. Outboard Tool Rest               | L. Quill                      |
| B. Outboard Handwheel               | M. Quill Lock                 |
| C. Headstock                        | N. Quill Adjustment Handwheel |
| D. Faceplate                        | O. Tailstock Base Lock        |
| E. Spur Center                      | P. Stand                      |
| F. Bed                              | Q. RPM Digital Readout        |
| G. Tool Rest                        | R. Speed Dial                 |
| H. Tool Rest Height Adjustment Lock | S. FWD/REV Switch             |
| I. Tool Rest Holder Lock            | T. Emergency STOP Button      |
| J. Tailstock                        | U. ON Button                  |
| K. Live Center                      |                               |





# MACHINE DATA SHEET

Customer Service #: (570) 546-9663 · To Order Call: (800) 523-4777 · Fax #: (800) 438-5901

## MODEL G0694 20" X 43" HEAVY-DUTY VARIABLE SPEED WOOD LATHE

### Product Dimensions:

Weight..... 578 lbs.  
 Length/Width/Height..... 103 x 25 x 49-1/2 in.  
 Foot Print (Length/Width)..... 77 x 16-1/2 in.

### Shipping Dimensions:

Type..... Wood Crate  
 Content..... Machine  
 Weight..... 710 lbs.  
 Length/Width/Height..... 85 x 26 x 58 in.

### Electrical:

Power Requirement..... 220V, Single-Phase  
 Inverter Type..... Delta VFD-E  
 Inverter Size..... 3 HP  
 Switch..... Push Button ON/OFF  
 Switch Voltage..... 220V  
 Cord Length..... 6 ft.  
 Cord Gauge..... 14 gauge  
 Minimum Circuit Size..... 15A  
 Plug Included..... No  
 Recommended Plug/Outlet Type..... NEMA 6-15

### Motors:

#### Main

Type..... TEFC Induction  
 Horsepower..... 3 HP  
 Voltage..... 220V  
 Phase..... Three  
 Amps..... 9A  
 Speed..... 50-1725 RPM  
 Cycle..... 60 Hz  
 Number Of Speeds..... Variable

### Main Specifications:

#### Operation Information

Swing Over Bed..... 20 in.  
 Dist Between Centers..... 43 in.  
 Swing Over Gap..... 24-7/8 in.  
 Swing Over Tool Rest..... 16 in.  
 Range Of Spindle Speeds..... Variable, 50-3000 RPM  
 Floor To Center Height..... 45 in.

#### Spindle Information

Spindle Taper..... MT#2  
 Spindle Size..... 1-1/4 in. x 8 TPI RH



**Tailstock Information**

Tailstock Taper..... MT#2

**Construction**

Bed Construction..... Precision Ground Cast Iron  
Stand Construction..... Pre-Formed Sheet Metal Cabinet  
Headstock Construction..... Cast Iron  
Tailstock Construction..... Cast Iron

**Features:**

- Single-Phase Inverter for 3-Phase Variable Speed Motor
- Included Spur & Live Centers
- 13-3/4 in. Wide Outboard Tool Rest
- Indexed Spindle Every 15 Degrees
- 3-Step Pulley System
- Reversible Variable Speed Motor Control
- Quick Release Belt Tension Lever for Quick Speed Range Changes



# SECTION 1: SAFETY

## WARNING

### For Your Own Safety, Read Instruction Manual Before Operating this Machine

The purpose of safety symbols is to attract your attention to possible hazardous conditions. This manual uses a series of symbols and signal words intended to convey the level of importance of the safety messages. The progression of symbols is described below. Remember that safety messages by themselves do not eliminate danger and are not a substitute for proper accident prevention measures.



Indicates an imminently hazardous situation which, if not avoided, **WILL** result in death or serious injury.



Indicates a potentially hazardous situation which, if not avoided, **COULD** result in death or serious injury.



Indicates a potentially hazardous situation which, if not avoided, **MAY** result in minor or moderate injury. It may also be used to alert against unsafe practices.

### **NOTICE**

This symbol is used to alert the user to useful information about proper operation of the machine.

## WARNING

### Safety Instructions for Machinery

- 1. READ ENTIRE MANUAL BEFORE STARTING.** Operating machine before reading the manual greatly increases the risk of injury.
- 2. ALWAYS USE ANSI APPROVED SAFETY GLASSES WHEN OPERATING MACHINERY.** Everyday eyeglasses only have impact resistant lenses—they are NOT safety glasses.
- 3. ALWAYS WEAR A NIOSH APPROVED RESPIRATOR WHEN OPERATING MACHINERY THAT PRODUCES DUST.** Most types of dust (wood, metal, etc.) can cause severe respiratory illnesses.
- 4. ALWAYS USE HEARING PROTECTION WHEN OPERATING MACHINERY.** Machinery noise can cause permanent hearing loss.
- 5. WEAR PROPER APPAREL. DO NOT** wear loose clothing, gloves, neckties, rings, or jewelry that can catch in moving parts. Wear protective hair covering to contain long hair and wear non-slip footwear.
- 6. NEVER OPERATE MACHINERY WHEN TIRED OR UNDER THE INFLUENCE OF DRUGS OR ALCOHOL.** Be mentally alert at all times when running machinery.





# WARNING

## Safety Instructions for Machinery

7. **ONLY ALLOW TRAINED AND PROPERLY SUPERVISED PERSONNEL TO OPERATE MACHINERY.** Make sure operation instructions are safe and clearly understood.
8. **KEEP CHILDREN/VISITORS AWAY.** Keep all children and visitors away from machinery. When machine is not in use, disconnect it from power, lock it out, or disable the switch to make it difficult for unauthorized people to start the machine.
9. **UNATTENDED OPERATION.** Leaving machine unattended while its running greatly increases the risk of an accident or property damage. Turn machine **OFF** and allow all moving parts to come to a complete stop before walking away.
10. **DO NOT USE IN DANGEROUS ENVIRONMENTS.** DO NOT use machinery in damp, wet locations, or where any flammable or noxious fumes may exist.
11. **KEEP WORK AREA CLEAN AND WELL LIGHTED.** Clutter and dark shadows may cause accidents.
12. **USE A GROUNDED POWER SUPPLY RATED FOR THE MACHINE AMPERAGE.** Grounded cords minimize shock hazards. Operating machine on an incorrect size of circuit increases risk of fire.
13. **ALWAYS DISCONNECT FROM POWER SOURCE BEFORE SERVICING MACHINERY.** Make sure switch is in OFF position before reconnecting.
14. **MAINTAIN MACHINERY WITH CARE.** Keep blades sharp and clean for best and safest performance. Follow instructions for lubricating and changing accessories.
15. **MAKE SURE GUARDS ARE IN PLACE AND WORK CORRECTLY BEFORE USING MACHINERY.**
16. **REMOVE CHUCK KEYS OR ADJUSTING TOOLS.** Make a habit of never leaving chuck keys or other adjustment tools in/on the machine—especially near spindles!
17. **DAMAGED MACHINERY.** Check for binding or misaligned parts, broken parts, loose bolts, other conditions that may impair machine operation. Always repair or replace damaged parts before operation.
18. **DO NOT FORCE MACHINERY.** Work at the speed for which the machine or accessory was designed.
19. **SECURE WORKPIECE.** Use clamps or a vise to hold the workpiece when practical. A secured workpiece protects your hands and frees both hands to operate the machine.
20. **DO NOT OVERREACH.** Maintain stability and balance at all times when operating machine.
21. **MANY MACHINES CAN EJECT WORKPIECES TOWARD OPERATOR.** Know and avoid conditions that cause the workpiece to "kickback."
22. **STABLE MACHINE.** Machines that move during operations greatly increase the risk of injury and loss of control. Verify machines are stable/secure and mobile bases (if used) are locked before starting.
23. **CERTAIN DUST MAY BE HAZARDOUS** to the respiratory systems of people and animals, especially fine dust. Be aware of the type of dust you are exposed to and always wear a respirator designed to filter that type of dust.
24. **EXPERIENCING DIFFICULTIES.** If at any time you are experiencing difficulties performing the intended operation, stop using the machine! Contact our Technical Support Department at (570) 546-9663.



## **WARNING**

# Additional Safety for Wood Lathes

- 1. KEEPING GUARDS IN PLACE.** Make sure all doors and guards are secured in place and that the lathe sits on a flat, stable surface.
- 2. EYE/FACE PROTECTION.** Always wear eye protection or a face shield when operating the lathe.
- 3. RESPIRATORY PROTECTION.** Always wear a respirator when using this machine. Wood dust may cause allergies or long-term respiratory health problems.
- 4. MOUNTING WORKPIECE.** Before starting, be certain the workpiece has been properly embedded on the spindle and tailstock centers and that there is adequate clearance for the full rotation.
- 5. ADJUSTING TOOL REST.** Adjust tool rest to provide proper support for the turning tool you will be using. Test tool rest clearance by rotating workpiece by hand before connecting the lathe to power.
- 6. TURNING SPEED.** Select the correct turning speed for your work, and allow the lathe to gain full speed before using.
- 7. USING SHARP CHISELS.** Keep lathe chisels properly sharpened and held firmly in position when turning.
- 8. OPERATING DAMAGED LATHE.** Never operate the lathe with damaged or worn parts.
- 9. FACEPLATE TURNING.** When faceplate turning, use lathe chisels on the downward spinning side of the workpiece only.
- 10. WORKPIECE CONDITION.** Always inspect the condition of your workpiece. **DO NOT** turn pieces with knots, splits, and other potentially dangerous conditions. Make sure joints of glued-up pieces have high quality bonds and will not fly apart during operation.
- 11. ADJUSTMENTS/MAINTENANCE.** Make sure your wood lathe is turned **OFF**, disconnected from its power source, and all moving parts have come to a complete stop before starting any inspection, adjustment, or maintenance procedure.
- 12. STOPPING LATHE.** **DO NOT** stop the lathe by using your hand against the workpiece. Allow the lathe to stop on its own.
- 13. AVOIDING ENTANGLEMENT.** Keep long hair and loose clothing articles such as sleeves, belts, and jewelry items away from the lathe spindle.
- 14. SANDING/POLISHING.** Remove the tool rest when performing sanding or polishing operations on the rotating workpiece.
- 15. MATERIAL REMOVAL RATE.** Attempting to remove too much material at once may cause the workpiece to fly out of the lathe.
- 16. SUPPORT ROD.** Hold the outboard tool rest support rod when making adjustments to avoid serious personal injury.
- 17. PREVENTING THROWN WORKPIECE.** Make sure that lathe is in its lowest speed when starting up. An out-of-balance workpiece or high RPM start can eject the workpiece.

## **WARNING**

Like all machinery there is potential danger when operating this lathe. Accidents are frequently caused by lack of familiarity or failure to pay attention. Use this lathe with respect and caution to reduce the risk of operator injury. If normal safety precautions are overlooked or ignored, serious personal injury may occur.



# SECTION 2: CIRCUIT REQUIREMENTS

## 220V Single-Phase Operation

### **!WARNING**

Serious personal injury could occur if you connect the machine to power before completing the setup process. **DO NOT** connect the machine to the power until instructed later in this manual.



### **!WARNING**

Electrocution or fire could result if machine is not grounded and installed in compliance with electrical codes. Compliance **MUST** be verified by a qualified electrician!

### Full Load Amperage Draw

This machine draws the following amps under maximum load:

Amp Draw.....9 Amps

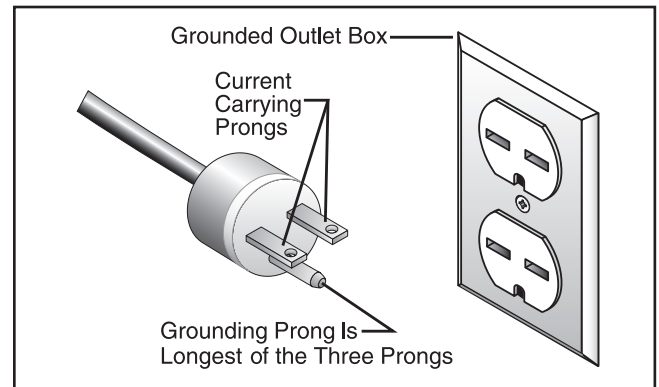
### Power Supply Circuit Requirements

The power supply circuit for your machine **MUST** be grounded and rated for the amperage given below. Never replace a circuit breaker on an existing circuit with one of higher amperage without consulting a qualified electrician to ensure compliance with wiring codes. **If you are unsure about the wiring codes in your area or you plan to connect your machine to a shared circuit, consult a qualified electrician.**

Minimum Circuit Size..... 15 Amps

### Power Connection Device

The type of plug required to connect your machine to power depends on the type of service you currently have or plan to install. We recommend using the plug shown in **Figure 2**.



**Figure 2.** NEMA 6-15 plug and receptacle.

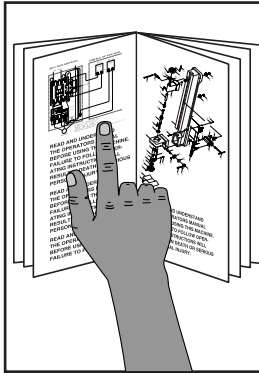
### Extension Cords

Using extension cords may reduce the life of the motor. Instead, place the machine near a power source. If you must use an extension cord:

- Use at least a 14 gauge cord that does not exceed 50 feet in length!
- The extension cord must also have a ground wire and plug pin.
- A qualified electrician **MUST** size cords over 50 feet long to prevent motor damage.

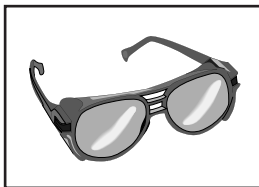


# SECTION 3: SETUP



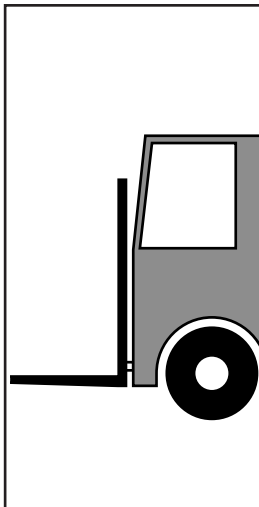
## **!WARNING**

This machine presents serious injury hazards to untrained users. Read through this entire manual to become familiar with the controls and operations before starting the machine!



## **!WARNING**

Wear safety glasses during the entire setup process!



## **!WARNING**

The Model G0694 is a heavy machine (approx. 580 lbs.) Serious personal injury may occur if safe moving methods are not used. To be safe, get assistance and use power lifting equipment rated for at least 750 lbs. to move the shipping crate and remove the machine from the crate.

## Needed for Setup

The following are needed to complete the setup process, but are not included with your machine.

Description	Qty
• Additional People .....	At Least 1
• Safety Glasses .....	1 For Each Person
• Cleaner/Degreaser ( <b>Page 12</b> ) ....	As Needed
• Disposable Shop Rags.....	As Needed
• Lifting Equipment (At Least 750 lb. Rating):	
—Forklift or Hoist .....	1
—Lifting Straps.....	2
• Mounting Hardware ( <b>Page 15</b> ) ...	As Needed
• Precision Level .....	1

## Unpacking

Your machine was carefully packaged for safe transportation. Remove the packaging materials from around your machine and inspect it. If you discover the machine is damaged, *please immediately call Customer Service at (570) 546-9663 for advice.*

Save the containers and all packing materials for possible inspection by the carrier or its agent. *Otherwise, filing a freight claim can be difficult.*

When you are completely satisfied with the condition of your shipment, inventory the contents.



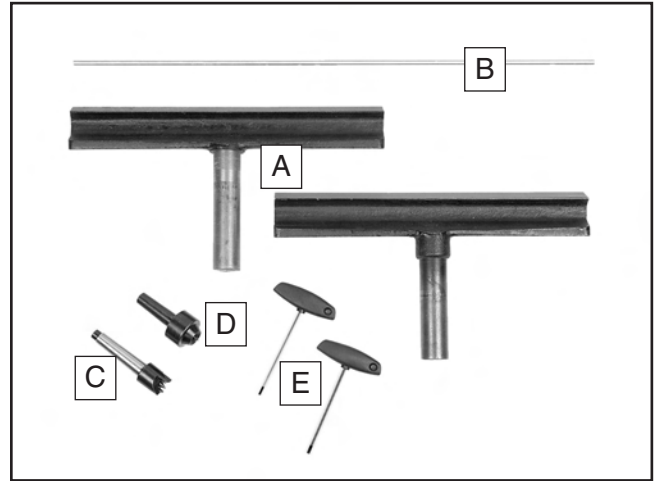
# Inventory

The following is a description of the small components shipped with your machine. Lay the components out to inventory them.


**Note:** *If you can't find an item on this list, check the mounting location on the machine or examine the packaging materials carefully. Occasionally we pre-install certain components for shipping purposes.*

Inventory: (Figure 3)	Qty
A. Tool Rests .....	2
B. Knockout Rod.....	1
C. Spur Center MT#2.....	1
D. Live Center MT#2.....	1
E. T-Handle Hex Wrenches 3, 4mm .....	1 Each

If any nonproprietary parts are missing (e.g. a nut or a washer), we will gladly replace them; or for the sake of expediency, replacements can be obtained at your local hardware store.



**Figure 3.** Model G0694 small component inventory.

	<p><b>⚠ WARNING</b>  <b>SUFFOCATION HAZARD!</b>  <b>Immediately discard all plastic bags and packing materials to eliminate choking/suffocation hazards for children and animals.</b></p>
---	---



# Cleanup

The unpainted surfaces of your machine are coated with a heavy-duty rust preventative that prevents corrosion during shipment and storage.

This rust preventative has been your machine's close ally and guardian since it left the factory. If your machine arrived to you free of rust, then be thankful that the rust preventative protected it during its journey...and try to stay thankful as you clean it off, because it can be challenging to remove if you are unprepared and impatient.

Plan on spending some time cleaning your machine. The time you spend doing this will reward you with smooth sliding parts and a better appreciation for the proper care of your machine's unpainted surfaces.

Although there are many ways to successfully remove the rust preventative, these instructions walk you through what works well for us.

## Before cleaning, gather the following:

- Disposable Rags
- Cleaner/degreaser (see below)
- Safety glasses & disposable gloves

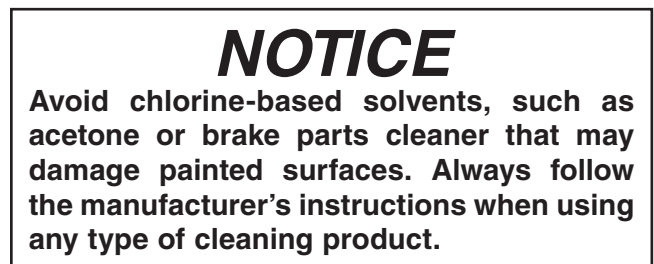
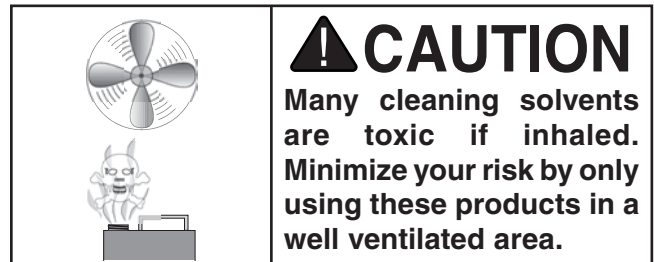
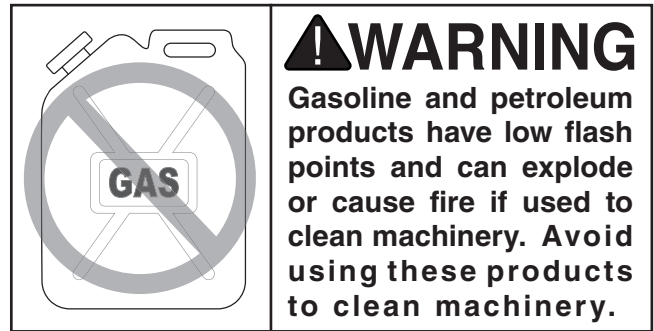
## H9692—Orange Power Cleaner & Degreaser

One of the best cleaners we've found for quickly and easily removing rust preventative.



**Figure 4.** Model H9692 Industrial Orange Power Cleaner/Degreaser (99.9% biodegradable).

**Note:** In a pinch, automotive degreasers, mineral spirits or WD•40 can be used to remove rust preventative. Before using these products, though, test them on an unnoticeable area of your paint to make sure they will not damage it.



## Basic steps for removing rust preventative:

1. Put on safety glasses and disposable gloves.
2. Coat all surfaces that have rust preventative with a liberal amount of your cleaner/degreaser and let them soak for few minutes.
3. Wipe off the surfaces. If your cleaner/degreaser is effective, the rust preventative will wipe off easily.

**Note:** To clean off thick coats of rust preventative on flat surfaces, such as tables, use a PLASTIC paint scraper to scrape off the majority of the coating before wiping it off with your rag. (Do not use a metal scraper or you may scratch your machine.)

4. Repeat **Steps 2–3** as necessary until clean, then coat all unpainted surfaces with a quality metal protectant to prevent rust.



# Site Considerations

## Weight Load

Refer to the **Machine Data Sheet** for the weight of your machine. Make sure that the surface upon which the machine is placed will bear the weight of the machine, additional equipment that may be installed on the machine, and the heaviest workpiece that will be used. Additionally, consider the weight of the operator and any dynamic loading that may occur when operating the machine.

## Space Allocation

Consider the largest size of workpiece that will be processed through this machine and provide enough space around the machine for adequate operator material handling or the installation of auxiliary equipment. With permanent installations, leave enough space around the machine to open or remove doors/covers as required by the maintenance and service described in this manual. **See below for working clearances.**

## Physical Environment

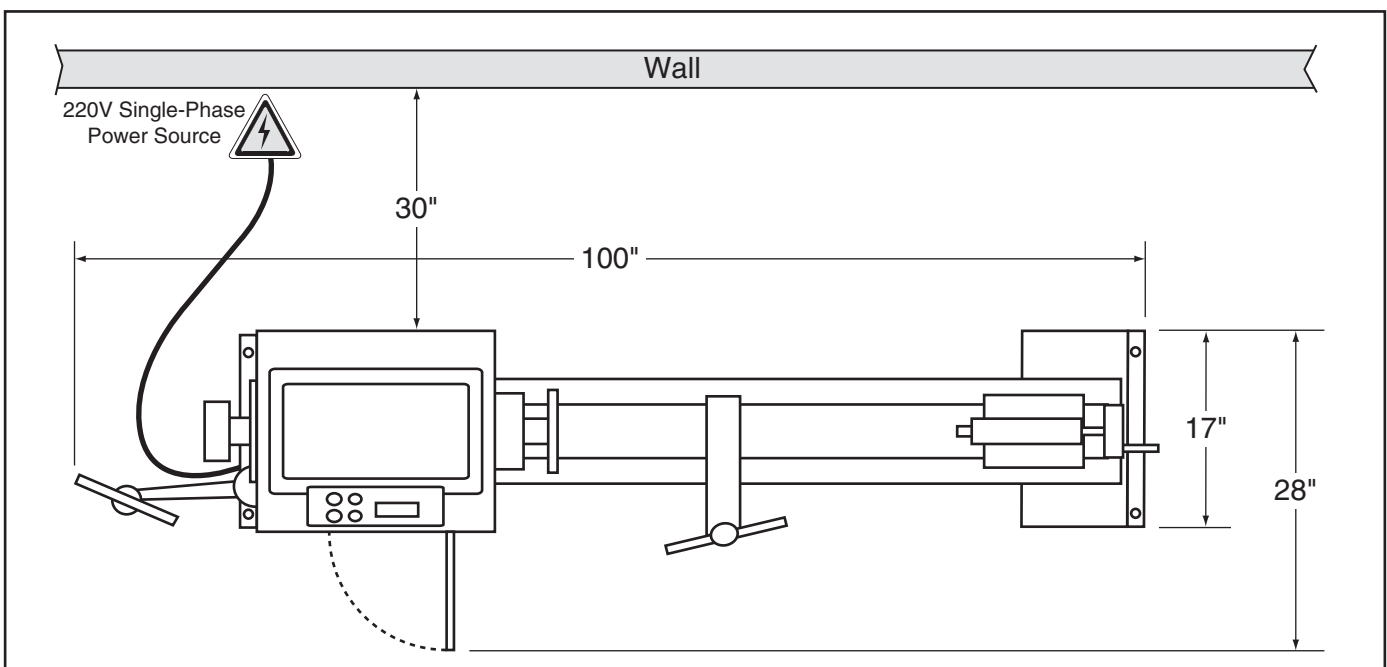
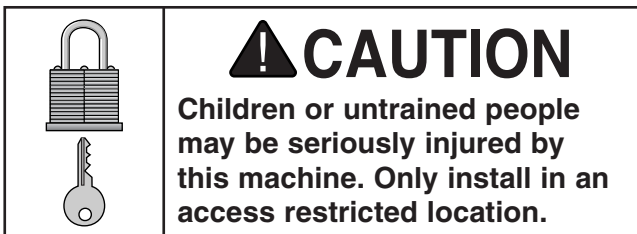
The physical environment where your machine is operated is important for safe operation and the longevity of its components. For best results, operate this machine in a dry environment that is free from excessive moisture, hazardous chemicals, airborne abrasives, or extreme conditions. Extreme conditions for this type of machinery are generally those where the ambient temperature range exceeds 41°–104°F; the relative humidity range exceeds 20–95% (non-condensing); or the environment is subject to vibration, shocks, or bumps.

## Electrical Installation

Place this machine near an existing power source. Make sure all power cords are protected from traffic, material handling, moisture, chemicals, or other hazards. Make sure to leave access to a means of disconnecting the power source or engaging a lockout/tagout device.

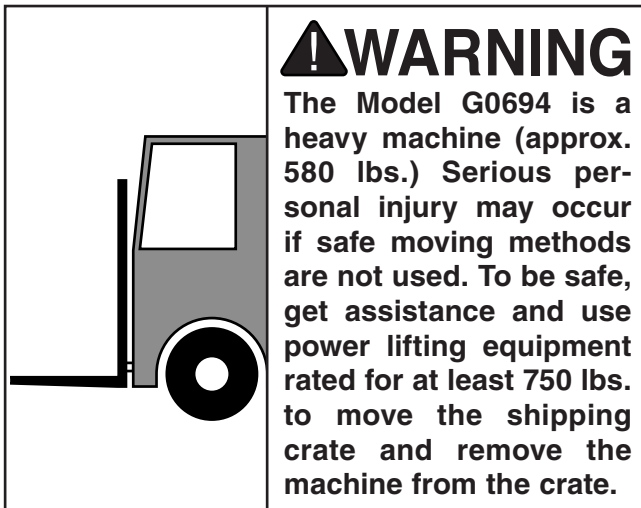
## Lighting

Lighting around the machine must be adequate enough that operations can be performed safely. Shadows, glare, or strobe effects that may distract or impede the operator must be eliminated.



**Figure 5.** Minimum working clearances.

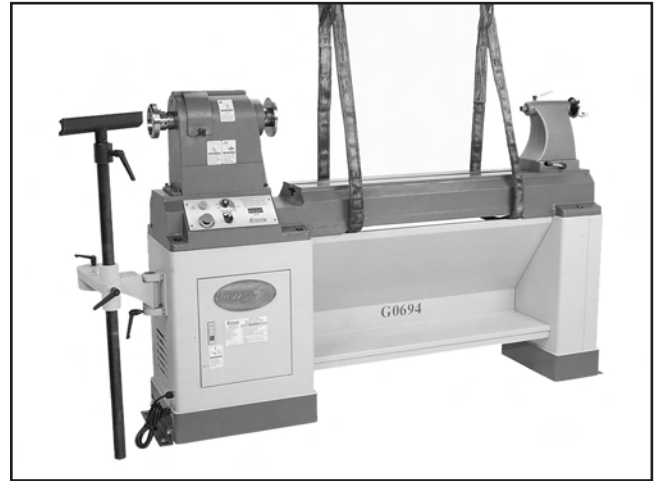
# Moving & Placing Lathe



## To move and place your lathe:

1. Remove the top crate from the shipping pallet.
2. To help balance the load, lock the outboard tool rest assembly as close as possible to the lathe body, then move the tailstock and center tool rest assembly to the extreme right of the bedway.
3. Remove the small items from the shipping pallet, then remove the lag bolts securing the lathe to the pallet.

4. Feed the lifting straps under the bedway, as shown in **Figure 6**, making sure they spread as wide as possible.



**Figure 6.** Lifting straps positioned to lift the lathe.

5. With assistance, steady the load and lift the lathe from the shipping pallet.  
—If the load is unbalanced, immediately lower the lathe and reposition the lifting straps as necessary. Repeat this step until you are satisfied that the load is safely balanced.
6. Have an assistant steady the load to keep it from swaying as you lift the lathe only enough to clear the shipping pallet and any floor obstacles, then move it to its working location.





# Mounting to Shop Floor

Although not required, we recommend that you mount your new machine to the floor. Because this is an optional step and floor materials may vary, floor mounting hardware is not included.

Use a precision level to make sure the bedways are level side-to-side and front-to-back. If necessary, place metal shims under the cabinets and mounting flanges.

The mounting flanges on either side of the lathe will accept  $\frac{3}{8}$ " mounting hardware (see Figure 7).

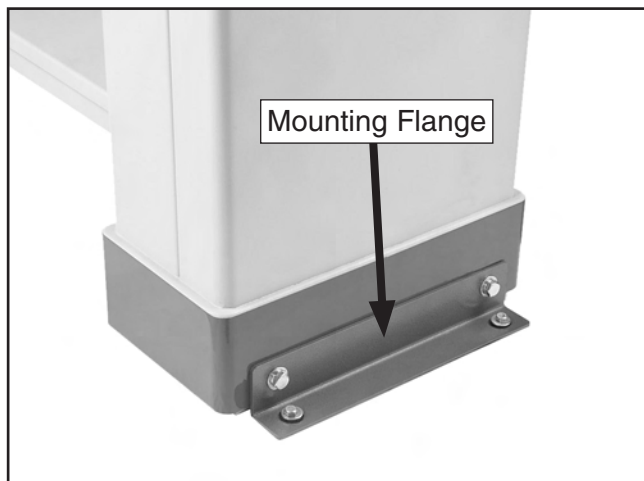


Figure 7. Right side mounting flange.

## **NOTICE**

To ensure long life from you lathe and good turning results, make sure the bedways are level side-to-side and front-to-back. Re-check the bedways two weeks after the initial placement of the machine, then annually thereafter.

## Bolting to Concrete Floors

Anchor studs and lag shield anchors with lag bolts (Figure 8) are two popular methods for anchoring an object to a concrete floor. We suggest you research the many options and methods for mounting your machine and choose the best that fits your specific application.

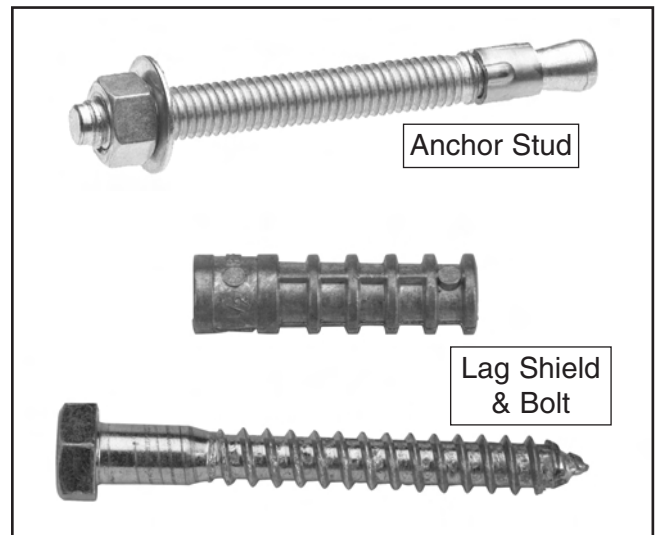


Figure 8. Typical fasteners for mounting to concrete floors.

## **NOTICE**

We strongly recommend securing your machine to the floor if it is hardwired to the power source. Consult with your electrician to ensure compliance with local codes.

# Test Run

Once the assembly is complete, test run your machine to make sure it runs properly and is ready for regular operation.

The test run consists of verifying the following: 1) The motor powers up and runs correctly, 2) the stop button safety feature works correctly, and 3) the motor turns the correct direction (machine is not wired out of phase).

If, during the test run, you cannot easily locate the source of an unusual noise or vibration, stop using the machine immediately, then review **Troubleshooting on Page 39**.

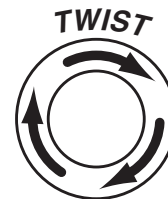
If you still cannot remedy a problem, contact our Tech Support at (570) 546-9663 for assistance.

## **! WARNING**

**Before starting the lathe, you must read through the rest of the manual and be familiar with the various functions and safety features on this machine. Failure to follow this warning could result in serious personal injury or even death!**

### To test run the machine:

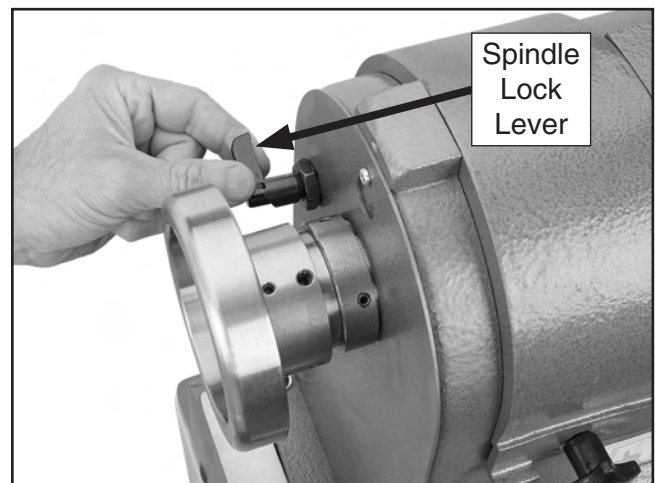
1. Make sure you understand the safety instructions at the beginning of the manual and that the machine is set up properly.
2. Make sure all tools and objects used during setup are cleared away from the machine.
3. Push the STOP button in, then twist it clockwise so it pops out. When the STOP button pops out, the switch is reset and ready for operation (see **Figure 9**).



## **STOP Button**

**Figure 9.** Resetting the switch.

4. To unlock the spindle so that it can freely rotate in the next steps, pull the spindle lock lever out and rotate it so that it is in the twelve o'clock position, as shown in **Figure 10**.



**Figure 10.** Unlocking the spindle.

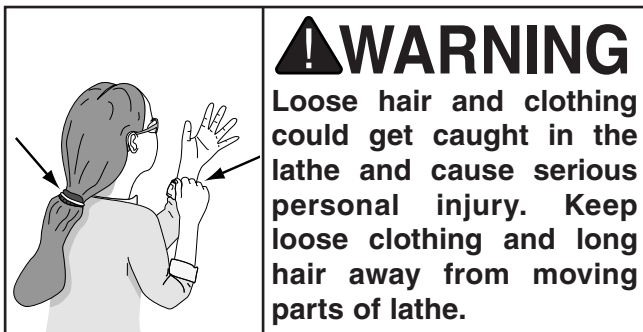
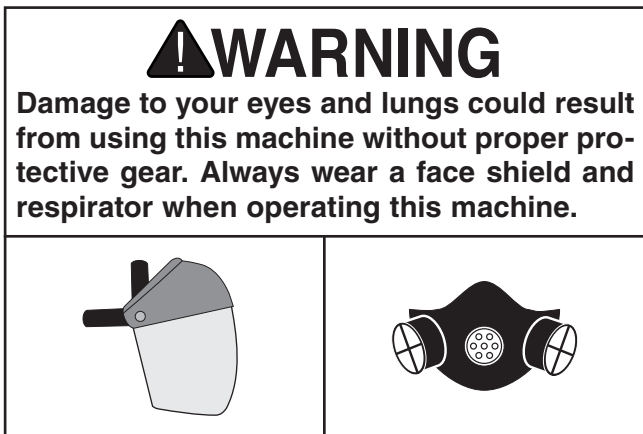
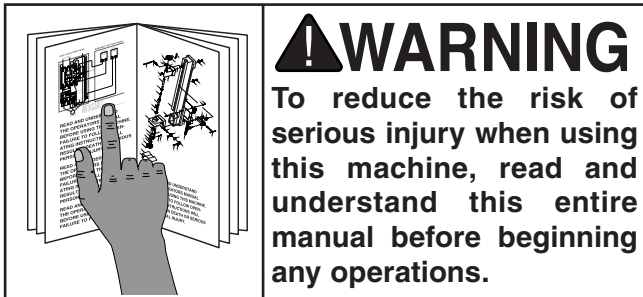
## **! CAUTION**

**Always disconnect the lathe from power before using the spindle lock feature. Never resume turning operations without making sure that the spindle lock is disengaged and the spindle turns freely by hand. Otherwise personal injury or property damage could result.**

5. Turn the speed dial counterclockwise to set the spindle speed at zero.
6. Connect the lathe to power.
7. Verify that the machine is operating correctly by pushing the ON button, then use the speed dial to increase the spindle speed.
  - When operating correctly, the machine runs smoothly with little or no vibration or rubbing noises.
  - Investigate and correct strange or unusual noises or vibrations before operating the machine further. Always stop the machine and disconnect it from power before investigating or correcting potential problems.
8. Press the STOP button to stop the machine.
9. WITHOUT resetting the switch, press the ON button. The machine should not start.
  - If the machine does not start, the STOP button safety feature is working correctly.
  - If the machine does start (with the STOP button pushed in), immediately disconnect power to the machine. The STOP button safety feature is not working correctly. This safety feature must work properly before proceeding with regular operations. Call Tech Support for help.
10. Verify that the power is not connected out of phase by starting/stopping the machine in the *FWD* direction and determining if the spindle turns in the *counterclockwise* direction (looking at the spindle from the tailstock side of the lathe).
  - If the spindle does NOT turn counterclockwise, it is turning in the wrong direction. Stop the machine, disconnect it from power, then swap any two of the three power wires inside the motor wiring junction box (refer to the **Wiring Diagram** on **Page 48** for specific information).



# SECTION 4: OPERATIONS

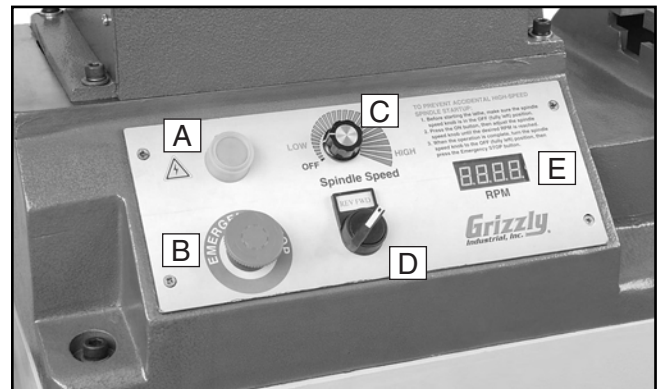


**NOTICE**

If you have never used this type of machine or equipment before, WE STRONGLY RECOMMEND that you read books, review industry trade magazines, or get formal training before beginning any projects. Regardless of the content in this section, Grizzly Industrial will not be held liable for accidents caused by lack of training.

## Basic Controls

See **Figure 11** and refer to the list of controls below to familiarize yourself with the lathe controls. You will find that understanding the names and descriptions of the controls is useful when reading this operations section.



**Figure 11.** Control panel.

- A. ON Button:** Starts the spindle rotation.
- B. Emergency STOP Button:** Turns the spindle rotation **OFF**.
- C. Speed Dial:** Adjusts the spindle speed from low to high within the range governed by the pulley belt position.
- D. FWD/REV Switch:** Toggles the spindle direction between clockwise or counterclockwise.
- E. RPM Digital Readout:** Indicates the spindle speed in RPM (rotations per minute).



# Operation Overview

---

This overview gives you the basic process that happens during an operation with this machine. Familiarize yourself with this process to better understand the remaining parts of the **Operation** section.

**To complete a typical operation, the operator does the following:**

1. Examines the workpiece to make sure it is suitable for turning. No extreme bows, knots, or cracks should exist.
2. Prepares and trims up the workpiece in a jointer or table saw to make it roughly concentric.
3. Installs the workpiece between centers.
4. Adjusts the tool rest to within  $\frac{1}{8}$ " of the workpiece centerline, and sets the minimum clearance between the workpiece and the lip of the tool rest to  $\frac{1}{4}$ " gap.
5. Positions and locks any dust collection hoods near the workpiece to collect wood chips, and secures in place.
6. Verifies the pulley ratio is set for the type of wood and size of workpiece installed.
7. Verifies the spindle speed dial is turned all the way counterclockwise so the spindle does not start in high speed.
8. Verifies the spindle direction switch is selecting the correct direction.
9. Verifies the spindle lock is disengaged, and the spindle and workpiece rotate freely throughout the full range of motion.
10. Ties back loose hair and clothing and puts on face shield and respirator. Takes all other required safety precautions.
11. Starts the lathe and dust collector, adjusts the lathe speed, and carefully begins the turning operation, keeping the chisel against the tool rest the entire time it is cutting.

# Stock Inspection & Requirements

---

Some workpieces are not safe to turn or may require modification before they are safe to turn. **Before turning a workpiece, inspect all workpieces for the following:**

- **Workpiece Type:**  
This machine is intended for cutting natural and man-made wood products, and some plastics. Never attempt to cut any metal, stone, or rubber workpiece; cutting these materials can lead to machine damage or severe injury.
- **Foreign Objects:**  
Nails, staples, dirt, rocks and other foreign objects are often embedded in wood. While cutting, these objects can become dislodged and hit the operator, cause tool grab, or break the turning tool, which might then fly apart. Always visually inspect your workpiece for these items. If they can't be removed, **DO NOT** turn the workpiece.
- **Large/Loose Knots:**  
Loose knots can become dislodged during the turning operation. Large knots can cause a workpiece to completely break in half during turning and cause machine damage and injury. Choose workpieces that do not have large/loose knots.
- **Wet or "Green" Stock:**  
Cutting wood with a moisture content over 20% causes unnecessary wear on tooling blades, increases the risk of tool grab, and yields poor results.
- **Excessive Warping:**  
Workpieces with excessive bowing or twisting are unstable and unbalanced. Never turn these workpieces at high speed, or instability will be magnified and the workpiece can be ejected from the lathe causing injury. Only turn concentric workpieces!

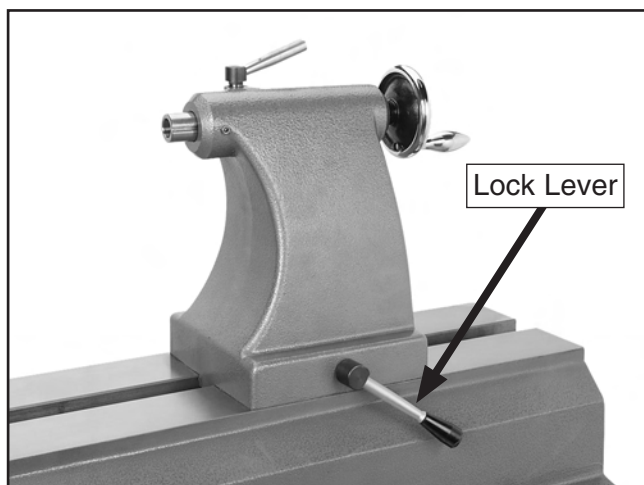


# Tailstock

The tailstock is equipped with a cam-action clamping system to secure it to the lathe bed. When the lever is tightened, a locking plate lifts up underneath the bed and clamps the tailstock in place.

## To position and lock the tailstock in position:

1. Loosen the lock lever and move the tailstock to the desired position along the bed (**Figure 12**).



**Figure 12.** Tailstock lock lever.

2. Re-engage the lock lever to secure the tailstock to the bed.

**Note:** The hex nut underneath the tailstock may require occasional tightening to restore proper clamping pressure and lever position. When adjusted properly, the lever should be at the horizontal position when the tailstock is fully clamped to the bed.

## **⚠️WARNING**

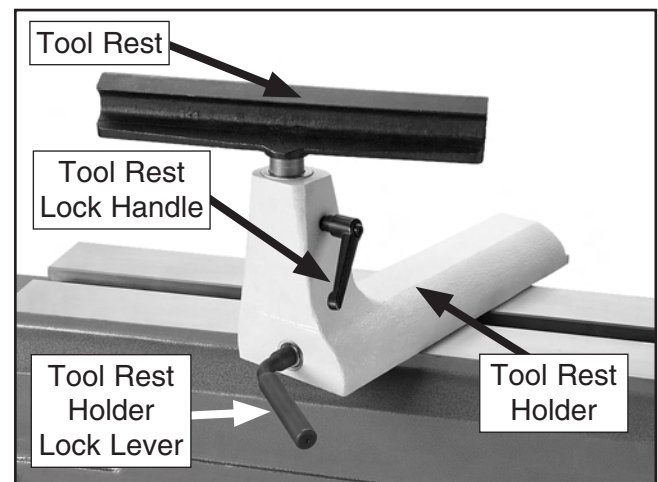
Always operate the lathe with the tailstock firmly locked to the bed. Otherwise, the workpiece can be ejected causing serious personal injury.

# Inboard Tool Rest

The tool rest holder is equipped with a cam-action clamping system to secure it to the lathe bed. When the tool rest holder lock lever is tightened, a locking plate lifts up and secures the tool rest assembly to the bed. The tool rest can also be positioned and locked at a specific angle or height.

## Positioning Inboard Tool Rest on Bedway

1. Loosen the tool rest holder lock lever and move the tool rest assembly to the desired position on the lathe bed (**Figure 13**).



**Figure 13.** Tool rest controls.

2. Re-engage the tool rest holder lock lever to secure the tool rest assembly in position.

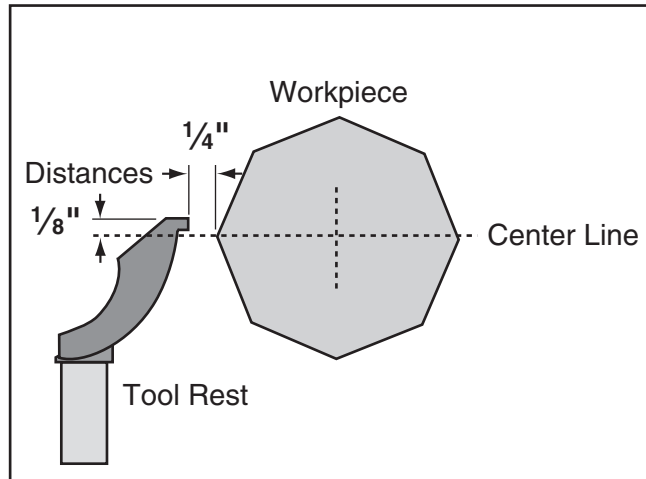
**Note:** The hex nut underneath the tool rest holder (**Figure 13**) may require occasional tightening to restore proper clamping pressure and lever position. When adjusted properly, the lever should be at the horizontal position when the tailstock is fully clamped to the bed.

## **⚠️WARNING**

Always operate the lathe with the tool rest holder firmly locked to the bed. Otherwise, the workpiece can be ejected causing serious personal injury.

## Adjusting Tool Rest Height

1. Loosen the tool rest lock handle and adjust the angle or height of the tool rest.
2. Position the tool rest approximately  $\frac{1}{4}$ " away from the workpiece and approximately  $\frac{1}{8}$ " above the workpiece center line (**Figure 14**).



**Figure 14.** Tool rest position relative to workpiece.

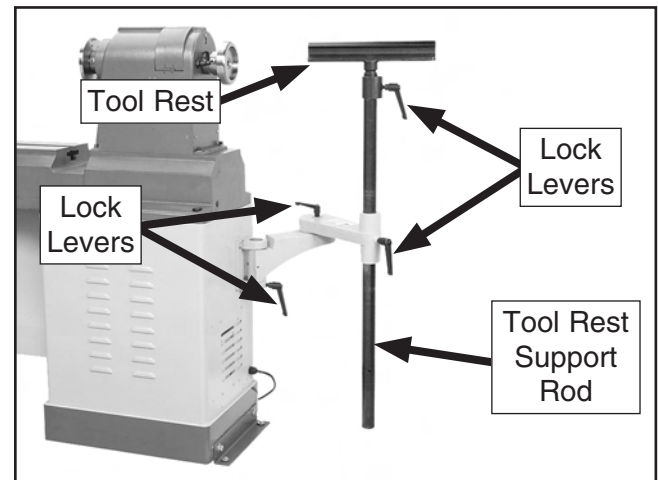
3. Re-tighten the tool rest lock handle to secure the tool rest in position.

## Outboard Tool Rest

When the workpiece is larger than 20" in diameter, mount the workpiece on the outboard side of the lathe and use the outboard tool rest.

### To use the outboard tool rest:

1. While firmly holding the tool rest support rod, loosen the lock levers shown in **Figure 15**.



**Figure 15.** Outboard tool rest assembly.

2. Adjust the tool rest support rod so that it rests firmly on the floor.
3. Adjust the position and height of the tool rest for your operation.

**Note:** As with the inboard tool rest, make sure the outboard tool rest is approximately  $\frac{1}{4}$ " away from the workpiece and approximately  $\frac{1}{8}$ " above the workpiece center line.

4. Firmly re-tighten all lock levers before starting the operation.

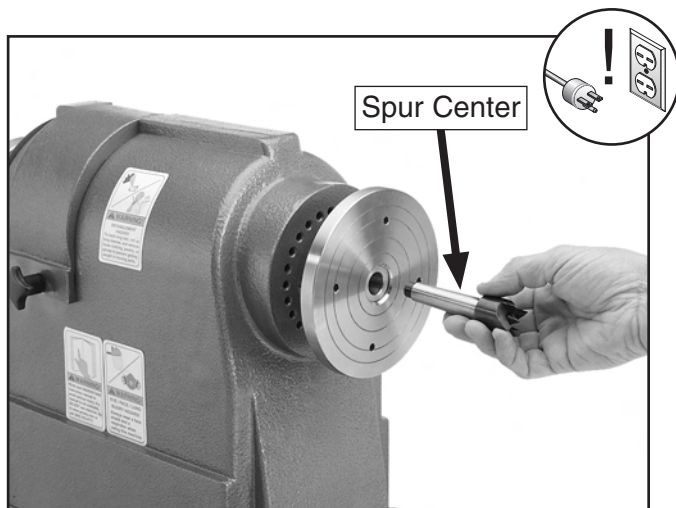


# Installing/Removing Headstock Center

The included spur center installs into the headstock spindle with an MT#2 tapered fit.

## Installing Headstock Center

1. DISCONNECT LATHE FROM POWER!
2. Make sure the mating surfaces of the center and spindle are free of debris and oily substances before inserting the center.
3. Insert the tapered end of the center into the spindle, and push it in with a quick, firm motion (**Figure 16**).



**Figure 16.** Installing center into the headstock spindle.

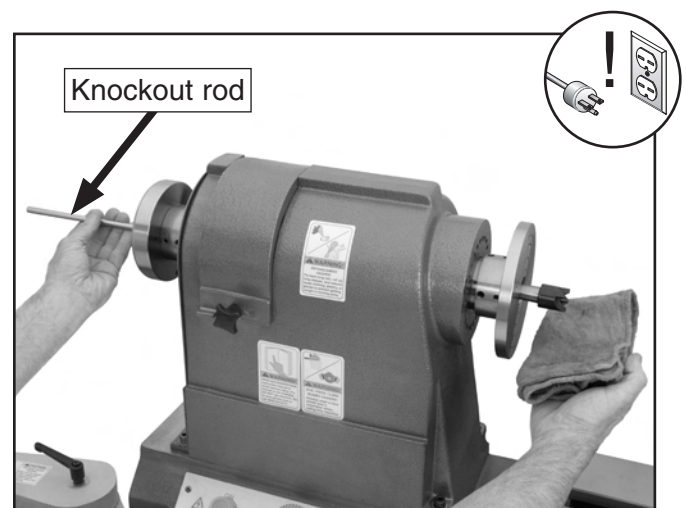
4. Make sure the center is securely installed by attempting to pull it out by hand—a properly installed center will not pull out easily.

## Removing Headstock Center

Tools Needed	Qty
Knockout Rod.....	1

### To remove the headstock center:

1. DISCONNECT LATHE FROM POWER!
2. Hold the center with a rag or a glove so the center does not fall to the floor when it pops free of the spindle.
3. Insert the knockout rod through the outbound end of the spindle and firmly tap the center to remove it, as shown in **Figure 17**.



**Figure 17.** Removing the headstock center.

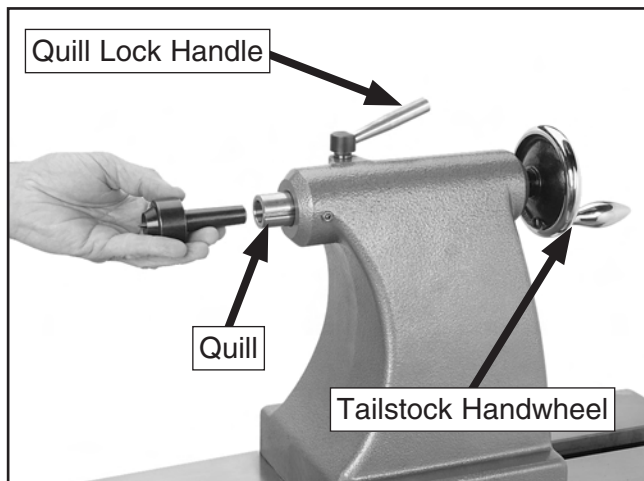


# Installing/Removing Tailstock Center

The included live center installs into the tailstock quill with an MT#2 tapered fit.

## To install the center into the tailstock quill:

1. Loosen the quill lock handle and rotate the tailstock handwheel until the quill extends about 1" (see **Figure 18**).



**Figure 18.** Installing center into tailstock quill.

2. Make sure the mating surfaces of the center and quill are free of debris and oily substances before inserting the center.
3. Insert the tapered end of the center into the tailstock quill, as shown in **Figure 18**.
4. Make sure the center is securely installed by attempting to pull it out by hand—a properly installed center will not easily pull out by hand.
5. Secure the quill in place by re-tightening the quill lock handle.

## To remove the center from the tailstock quill:

1. Loosen the quill lock handle.
2. Hold the center with a rag or a glove so the center does not fall to the floor when it is pushed free of the tailstock.
3. Rotate the tailstock handwheel counterclockwise—the tailstock quill will retract back into the quill, causing the center to be released from the quill.

# Installing Faceplate/ Handwheel

## ⚠ CAUTION

Always disconnect the lathe from power before using the spindle lock feature. Never resume turning operations without making sure that the spindle lock is disengaged and the spindle turns freely by hand. Otherwise personal injury or property damage could result.

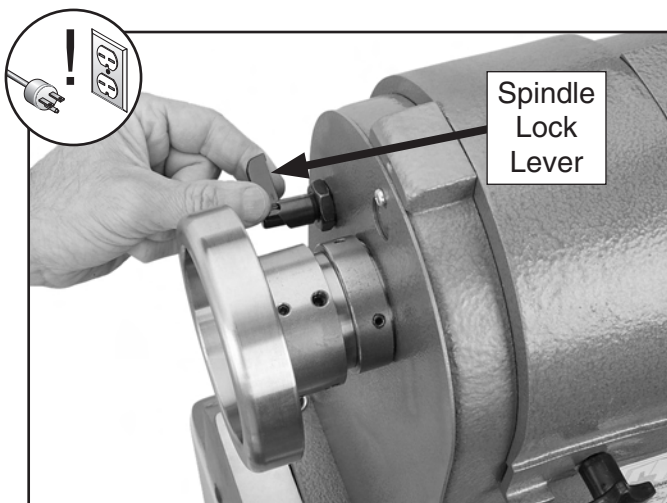
The faceplate can be mounted on the outboard side of the lathe for turning workpieces larger than 20" in diameter. In this case, the handwheel is mounted on the inboard side.

To mount a workpiece to the faceplate, refer to **Faceplate Turning** on **Page 30**.

Tools Needed	Qty
T-Handle Hex Wrench 3mm.....	1

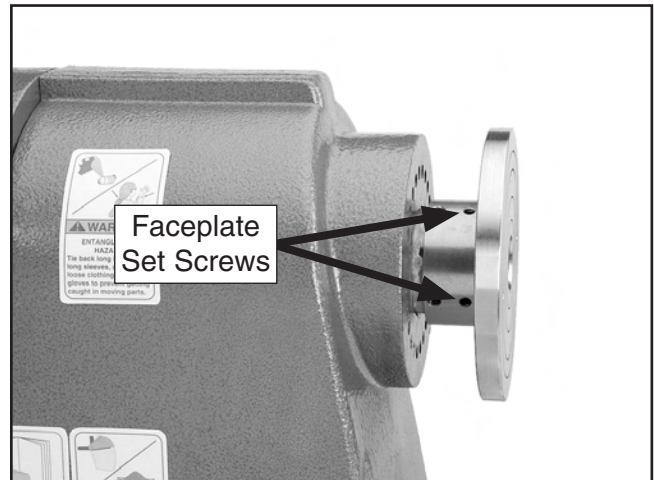
## Installing Faceplate or Handwheel

1. DISCONNECT LATHE FROM POWER!
2. Pull the spindle lock lever out, then rotate it from the twelve o'clock unlocked position to the six o'clock locked position (see **Figure 19**).



**Figure 19.** Using the spindle lock lever.

3. Rotate the spindle by hand until the lock pin engages and keeps the spindle from rotating.
4. Apply a thin coat of light machine oil on the spindle threads, then thread the faceplate or handwheel onto the spindle until it is snug.
5. Tighten the four faceplate or handwheel set screws just behind the faceplate to secure it to the spindle (see **Figure 20**).



**Figure 20.** Headstock faceplate set screw.

## ⚠ WARNING

To prevent the workpiece from flying off during operation, the faceplate **MUST** be firmly threaded onto the spindle and secured in place by fully tightening the four faceplate set screws. If these instructions are not properly performed, serious personal injury could occur.

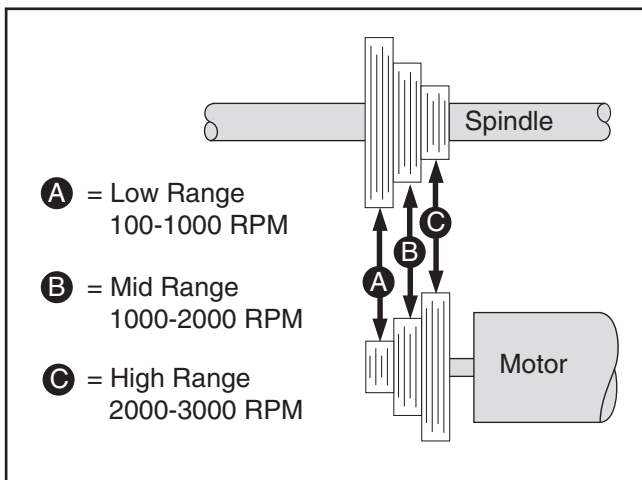
6. Move the spindle lock lever from the six o'clock locked position to the twelve o'clock unlocked position.

## Removing Faceplate or Handwheel

Apply the spindle lock, loosen the four set screws, and unthread the faceplate or handwheel.

# Adjusting Spindle Speeds

The Model G0694 has three speed ranges for maximum turning options. These ranges are selected by changing belt positions on the motor and spindle pulleys (**Figure 21**).



**Figure 21.** Speed ranges for each belt position.

When turning a workpiece where a lot of material must be removed and a rough finish does not matter, low range, which has more torque, is best. When turning a workpiece where a clean finish is required, and only light cuts are made, high range is best. Mid range is a compromise between the two ranges. Use the speed dial to adjust the spindle speed within each range.

## ⚠️ WARNING

Always choose the correct spindle speed for your operation. Using the wrong speed may lead to the workpiece breaking loose or being thrown from the lathe at a high rate of speed, causing fatal or severe impact injuries.

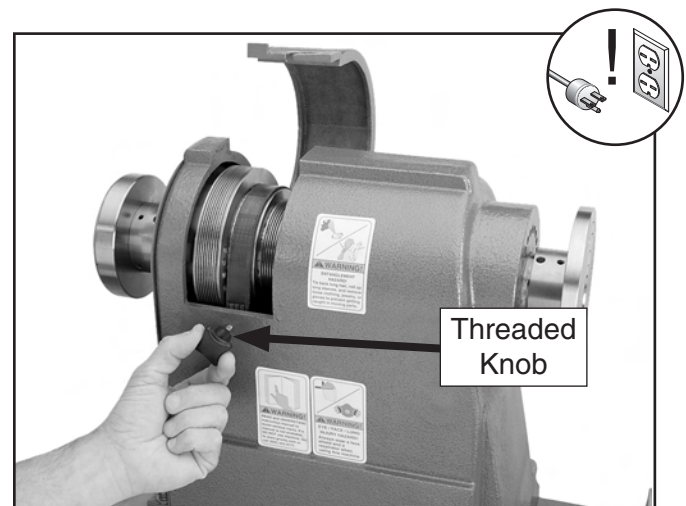
Refer to the chart in **Figure 22** help choosing the correct spindle speed. Note that both the diameter of the workpiece and the type of cutting determines the spindle speed.

Diameter of Work-piece	Roughing RPM	General Cutting RPM	Finishing RPM
Under 2"	1520	3000	3000
2-4"	760	1600	2480
4-6"	510	1080	1650
6-8"	380	810	1240
8-10"	300	650	1000
10-12"	255	540	830
12-14"	220	460	710
14-16"	190	400	620

**Figure 22.** Model G0694 typical spindle speed recommendations.

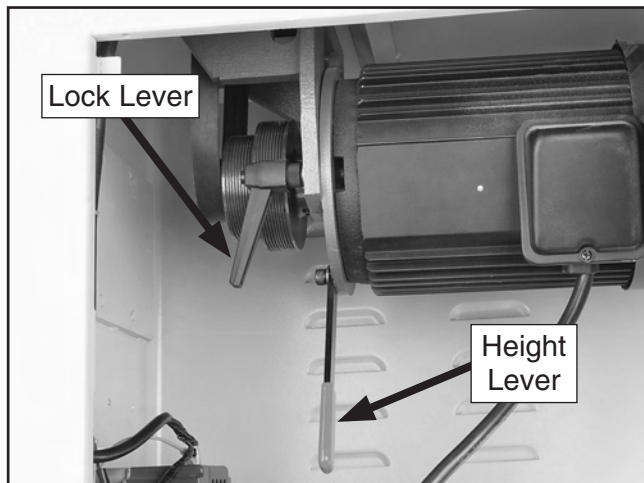
### To change speed ranges:

1. DISCONNECT LATHE FROM POWER!
2. Remove the threaded knob and open the upper belt access panel, as shown in **Figure 23**.



**Figure 23.** Belt access panel removed.

3. Open the cabinet door, loosen the lock lever, pull up on the height lever to raise the motor to the highest position, then re-tighten the lock lever to secure the motor in place (**Figure 24**).



**Figure 24.** Motor lock and height levers.

4. Position the belt on the motor and spindle pulleys for the correct speed range.
5. Loosen the lock lever and allow the motor weight to tension the belt. There should be almost no belt looseness or belt deflection.

**Note:** *If the motor does not hang freely against the belt, you may have to manually push the height lever to tension the belt.*

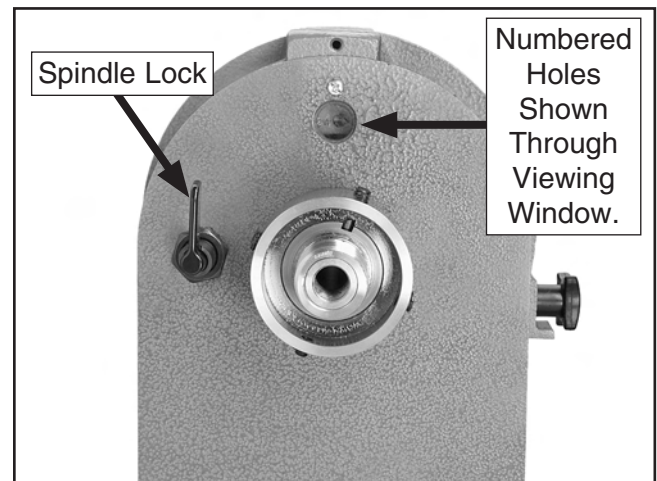
6. Tighten the lock lever.
7. Close the belt access panel and cabinet door.

## Indexing

Indexing on a lathe is typically used for workpiece layout and other auxiliary operations that require equal distances around the workpiece circumference, such as clock faces or inlays.

By applying the spindle lock into one of the 24 holes in the spindle, the workpiece can be positioned to one of 24 equal points that are 15° degrees apart.

For special sequencing of positions, each spindle position has its own number, which can be viewed through the viewing window, as shown in **Figure 25**, on the outboard side of the headstock.



**Figure 25.** Spindle lock lever and viewing window.

### **NOTICE**

**Always disconnect the lathe from power before using the spindle lock feature. Never resume turning operations without making sure that the spindle lock is disengaged and the spindle turns freely by hand. Otherwise machine damage could result.**

# Selecting Turning Tools

Lathe tools come in a variety of shapes and sizes, and usually fall into five major categories.

- **Gouges**—Mainly used for rough cutting, detail cutting, and cove profiles. The rough gouge is a hollow, double-ground tool with a round nose, and the detail gouge is a hollow, double-ground tool with either a round or pointed nose.

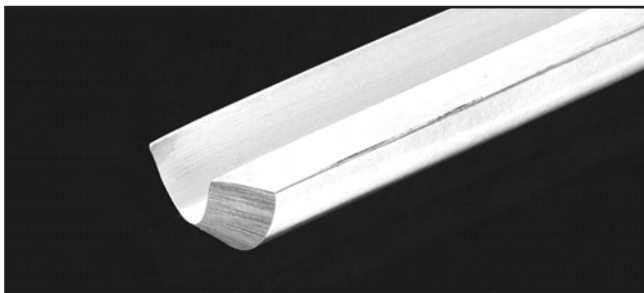


Figure 26. Example of a gouge.

- **Skew Chisel**—A very versatile tool that can be used for planing, squaring, V-cutting, beading, and parting off. The skew chisel is flat, double-ground with one side higher than the other (usually at an angle of 20°–40°).

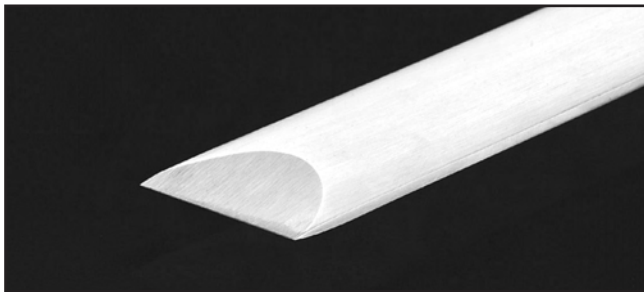


Figure 27. Example of a skew chisel.

- **Scrapers**—Typically used where access for other tools is limited, such as hollowing operations. This is a flat, double-ground tool that comes in a variety of profiles (round nose, spear point, square nose, etc.) to match many different contours.



Figure 28. Example of a round nose scraper.

- **Parting Tools**—Used for sizing and cutting off work. This is a flat tool with a sharp pointed nose that may be single- or double-ground.

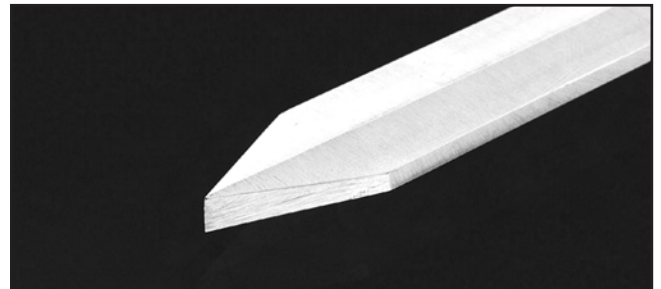
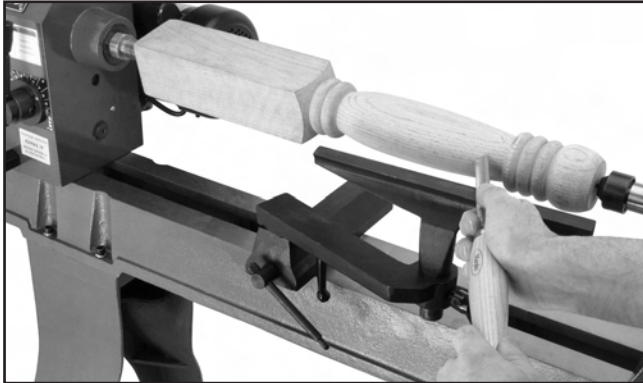


Figure 29. Example of a parting tool.

- **Specialty Tools**—These are the unique, special function tools to aid in hollowing, bowl making, cutting profiles, etc. The Swan Neck Hollowing Tool shown on **Page 34** is a good example of a speciality tool.

# Spindle Turning

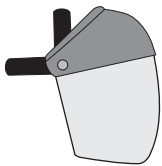
Spindle turning is the operation performed when a workpiece is mounted between the headstock and the tailstock (see **Figure 30** for an example).



**Figure 30.** Typical spindle turning operation.

## **!WARNING**

Damage to your eyes and lungs could result from using this machine without proper protective gear. Always wear a face shield and respirator when operating this machine.

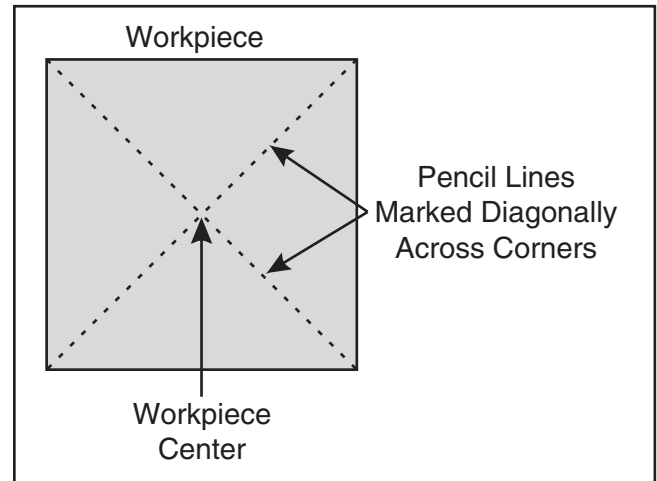


## **NOTICE**

Always disconnect the lathe from power before using the spindle lock feature. Never resume turning operations without making sure that the spindle lock is disengaged and the spindle turns freely by hand. Otherwise machine damage could result.

## Setting Up for Spindle Turning

1. Find the center point of both ends of your workpiece by drawing diagonal lines from corner to corner across the end of the workpiece (**Figure 31**).



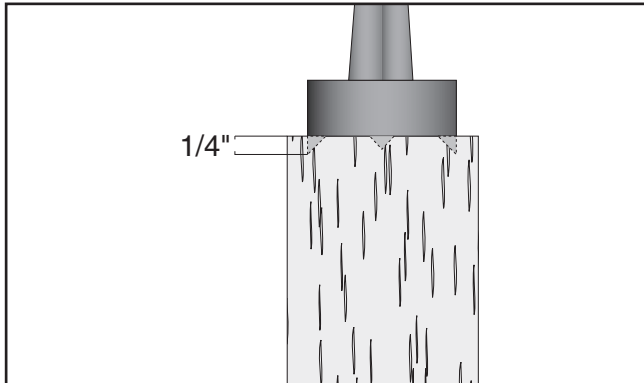
**Figure 31.** Workpiece marked diagonally from corner to corner to determine the center.

2. Using a wood mallet and spur center, tap a center mark into both ends of the workpiece.
3. Using a  $\frac{1}{4}$ " drill bit, drill a  $\frac{1}{4}$ " deep hole at the center mark on the end of the workpiece to be mounted on the headstock spur center.
4. To help embed the spur center into the workpiece, cut  $\frac{1}{8}$ " deep saw kerfs in the same end of the workpiece along the diagonal lines marked in **Step 1**.

**Note:** If your workpiece is over 2" x 2", cut the corners off the workpiece lengthwise to make turning safer and easier.



5. Making sure the spur center is aligned with the workpiece center you marked earlier, drive the spur center least  $\frac{1}{4}$ " into the end of the workpiece (**Figure 32**).



**Figure 32.** Spur center properly embedded.

6. With the workpiece still attached, insert the spur center into the headstock spindle (refer to **Installing/Removing Headstock Center** on **Page 22** for additional instructions).

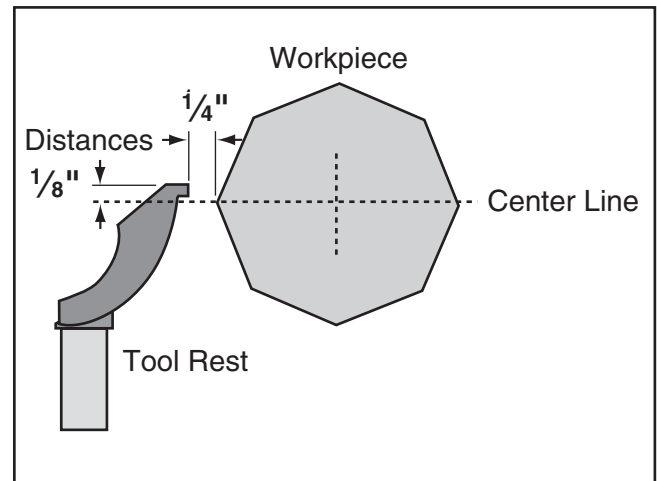
**Note:** Use the tool rest to support the opposite end of the workpiece so that the workpiece and spur center do not separate.

7. Install the live center into the tailstock quill and tighten the quill lock handle to lock the quill in position (refer to **Page 23** for additional instructions).
8. Slide the tailstock toward the workpiece until the point of the live center touches the workpiece center mark, then lock the tailstock in this position.
9. Loosen the quill lock handle and rotate the tailstock handwheel to push the live center into the workpiece at least a  $\frac{1}{4}$ ".

## ⚠ WARNING

Do not press the workpiece too firmly with the tailstock or the bearings will bind and overheat. Likewise, do not adjust too loosely or the workpiece will spin off the lathe. Use good reason and care, otherwise, serious personal injury could result.

10. Position the tool rest approximately  $\frac{1}{4}$ " away from the workpiece and approximately  $\frac{1}{8}$ " above the workpiece center line (**Figure 33**).



**Figure 33.** Tool rest position relative to workpiece.

11. Before beginning lathe operation, rotate the workpiece by hand to ensure that there is safe clearance through the full rotation.

## ⚠ WARNING

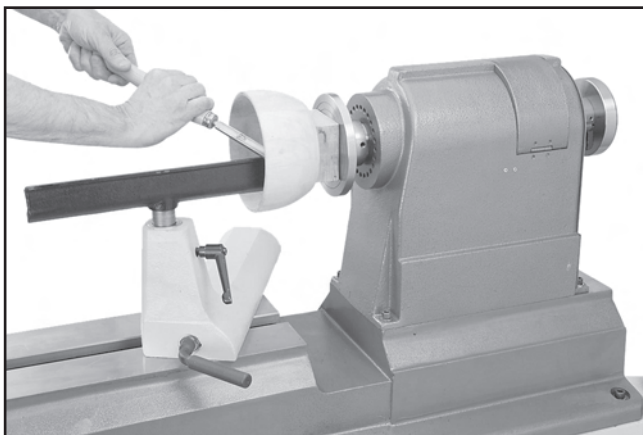
Keep the turning tool on the tool rest the **ENTIRE** time that it is in contact with the workpiece. Otherwise, the spinning workpiece could force the lathe tool out of your hands or entangle your hands with the workpiece.

## Spindle Turning Safety Tips

- When turning the lathe **ON**, stand away from the path of the spinning workpiece until the lathe reaches full speed and you can verify that the workpiece will not come loose.
- Use the slowest speed when starting or stopping the lathe.
- Select the right speed range and speed for the size of the workpiece and the type of cut (refer to **Adjusting Spindle Speed** on **Page 25** for detailed instructions and guidelines).
- Learn the correct techniques for the tools you use. If you are unsure about how to use the lathe or any lathe tool, read books or magazines about lathe techniques and seek training from experienced lathe users.

## Faceplate Turning

Faceplate turning is done when a workpiece is mounted to the faceplate, which is then mounted to the headstock spindle. This type of turning is usually done with open-faced workpieces like bowls or plates (see **Figure 34** for an example).



**Figure 34.** Typical faceplate turning operation.

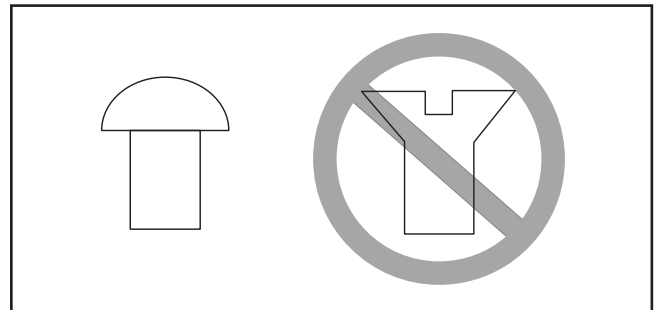
## Mounting Workpiece on Faceplate

1. Mark the workpiece center as in **Spindle Turning** (see **Page 28**).

**Note:** *Cut off corners of the workpiece to make it as close to "round" as possible.*

### **NOTICE**

Only use tap screws or wood screws with non-tapered heads (**Figure 35**) to attach the faceplate to the workpiece. Do NOT use dry-wall screws or screws with tapered heads, because they can split the faceplate or snap off during operation.



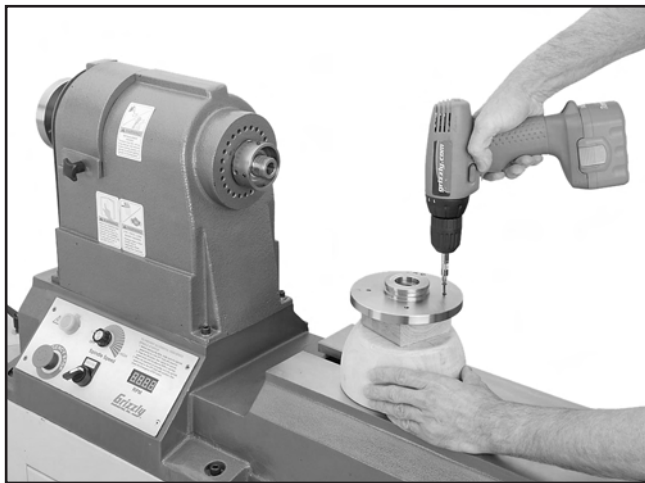
**Figure 35.** Correct and incorrect screw types for mounting faceplate to workpiece.

2. Center the faceplate on the workpiece and attach it with wood screws that do not have tapered heads.
3. Thread and secure the faceplate onto the headstock spindle (refer to **Headstock/Faceplate** on **Page 24** for faceplate mounting instructions).



## Using Backing Block

If wood screws cannot be placed in the workpiece, then the faceplate can be mounted on a backing block that is glued to the workpiece (see **Figure 36** for an example).



**Figure 36.** Typical attachment of faceplate to workpiece (shown with backing block).

### To mount your workpiece to a backing block:

1. Make the backing block from a piece of scrap wood that is flat on both sides.
2. Locate and mark the center of both the workpiece and backing block.
3. Drill a 1/4" hole through the center of the backing block.
4. Looking through the hole in the backing block to line up the center with the workpiece, glue and clamp the backing block to the workpiece.

**Note:** Allow the glue to cure according to the manufacturer's instructions.

5. Attach the faceplate as detailed in the previous subsection.

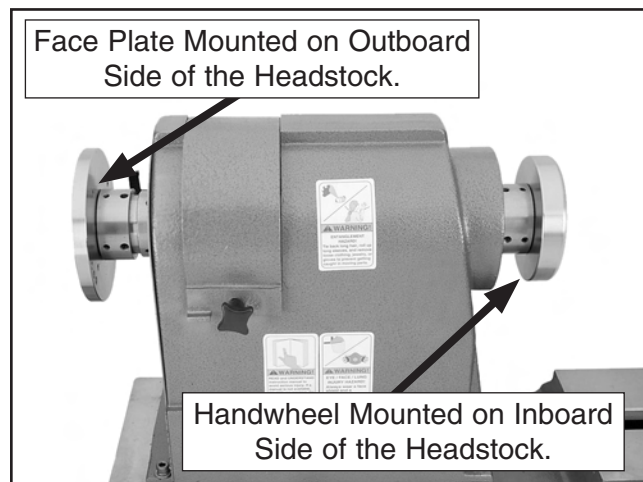
## Outboard Turning

### **!WARNING**

Keep the lathe chisel against the tool rest the **ENTIRE** time you are cutting or when feeding the chisel into the workpiece. Otherwise, the spinning workpiece could knock the chisel out of your hands or pull your hands into the workpiece, resulting in serious entanglement or impact injuries.

When the workpiece is larger than 20" in diameter, mount it on the outboard side of the lathe.

To do this, swap the faceplate and handwheel positions as shown in **Figure 37** (refer to **Installing Faceplate/Handwheel** on **Page 24** for detailed instructions).



**Figure 37.** Spindle setup for outboard turning.

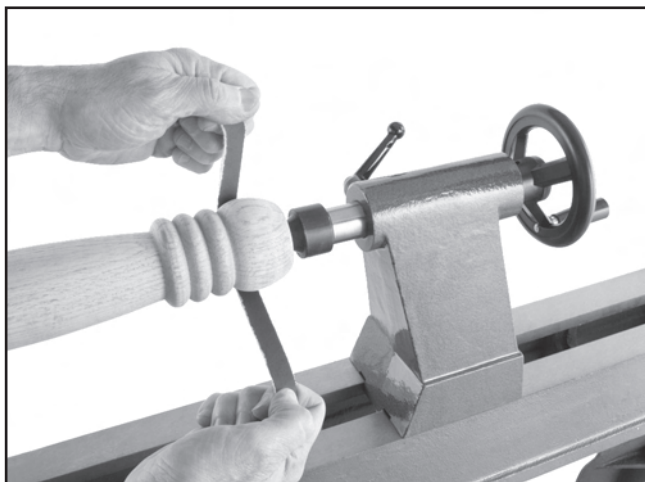
As well, you must use the outboard tool rest (refer to **Outboard Tool Rest** on **Page 21** for detailed instructions).

### **!WARNING**

When outboard turning, rotate the workpiece by hand before connecting the machine to power to make sure that it will not come in contact with any obstacle. Otherwise, it could break apart during operation and cause serious impact injuries.

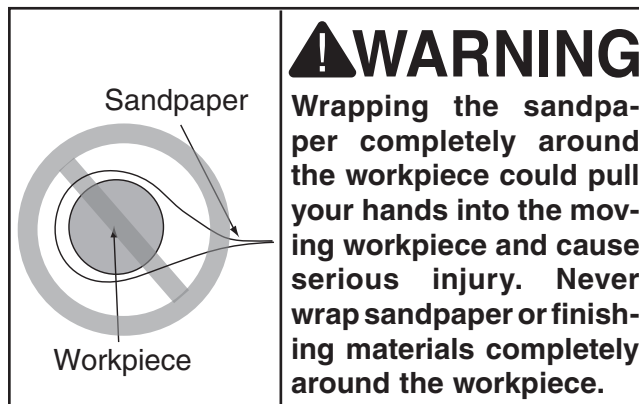
# Sanding/Finishing

After the turning operations are complete, the workpiece can be sanded and finished before removing it from the lathe (see **Figure 38** for an example).



**Figure 38.** Typical sanding operation.

**Note:** *Whenever sanding or finishing, move the tool rest holder out of the way to increase personal safety and gain adequate working room.*



# SECTION 5: ACCESSORIES

## G1194—3-Jaw Chuck

A "must have" for the serious wood turner. This 3-jaw chuck is a self-centering style chuck used mostly for round work. All three jaws tighten together at the same time. Jaws are reversible for expanded work holding capacity. *Threaded insert required for mounting!*



Figure 39. Model G1194 3-Jaw Chuck.

## H1064—6-PC Deluxe HSS Lathe Chisel Set

This deluxe chisel set features beefy ash handles for unsurpassed control, brass ferrules and high speed steel blades. Includes: a 17" long  $\frac{13}{16}$ " Parting Tool,  $\frac{13}{16}$ " Round Nose and  $\frac{3}{8}$ " Gouge; a 19" long 1" Skew, a  $\frac{5}{8}$ " Gouge and a 22 $\frac{3}{4}$ " long  $\frac{3}{8}$ " Gouge. Comes in a beautiful blow molded carrying case. An extremely popular set!



Figure 42. Model H1064 6-PC Chisel Set.

## G3167— $\frac{1}{4}$ " x 8 TPI RH Threaded Insert

This threaded insert is required to mount a 3- or 4-jaw chuck to your wood lathe.

## T20501—Face Shield Crown Protector 4"

## T20502—Face Shield Crown Protector 7"

## T20503—Face Shield Window

## T20452—"Kirova" Anti-Reflective S. Glasses

## T20451—"Kirova" Clear Safety Glasses

## H0736—Shop Fox® Safety Glasses

## H7194—Bifocal Safety Glasses 1.5

## H7195—Bifocal Safety Glasses 2.0

## H7196—Bifocal Safety Glasses 2.5

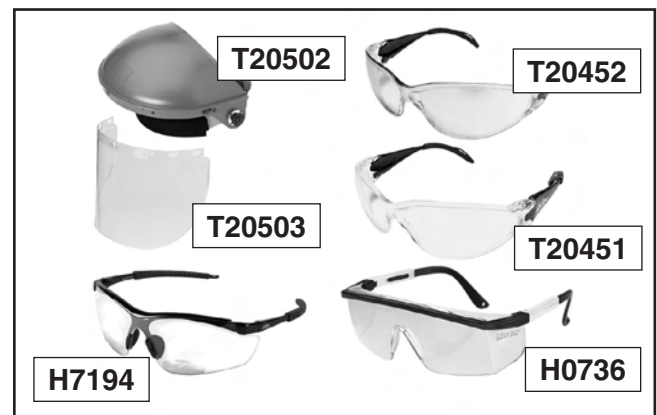


Figure 78. Eye protection assortment.

## G1082—4-Jaw Chuck

Another "must have" for the serious wood turner. This 4-jaw chuck is an independent type chuck that is used for square and odd-shaped pieces. Each jaw tightens individually and can be turned around to hold larger dimension workpieces. *Threaded insert required for mounting!*

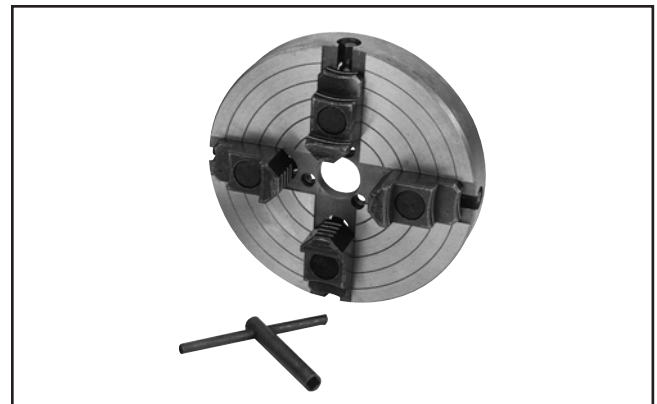


Figure 40. Model G1082 4-Jaw Chuck.

Call 1-800-523-4777 To Order

Model G0694 (Mfg. Since 1/09)

**H6542—Robert Sorby HSS 8-PC Turning Set**  
 If quality is king, then start bowing. Made in England, these Robert Sorby lathe tools are especially for the perfectionist wood turner. Includes  $\frac{3}{4}$ " roughing gouge,  $\frac{3}{8}$ " &  $\frac{1}{2}$ " spindle gouge,  $\frac{3}{8}$ " bowl gouge,  $\frac{3}{4}$ " standard skew,  $\frac{3}{16}$ " diamond side cut scraper, 1" square scraper and  $\frac{1}{2}$ " round scraper. Full size handles are 16"—19".



**Figure 43.** Model H6542 Robert Sorby 8-PC Set.

**G9863—8-PC HSS Lathe Chisel Set**  
 This chisel set features beautiful 8" ash handles with brass ferrules and  $3\frac{1}{2}$ " long, high speed steel blades. Chisels include:  $\frac{1}{2}$ " parting tool,  $\frac{1}{2}$ " straight chisel,  $\frac{1}{2}$ " double bevel skew,  $\frac{1}{2}$ " roundnose,  $\frac{3}{4}$ " gouge,  $\frac{3}{8}$ " gouge,  $\frac{1}{2}$ " diamond point and  $\frac{3}{8}$ " veiner. Set comes in fitted wooden case, and is very competitively priced!



**Figure 44.** Model G9863 8-PC Chisel Set.

**H6204—Precision Drill Chuck  $\frac{1}{32}$ "— $\frac{5}{8}$ " x JT#3**  
**G1676—Drill Chuck Arbor MT#2 x JT#3**  
 The best way to bore holes with your lathe!

**H0507—20" Swan Neck Hollowing Tool**  
**H0508—24" Swan Neck Hollowing Tool**  
 An excellent choice for blind turning or undercutting where reach is restricted. H0507 is designed for end grain use while H0508 (with a more substantial steel cross section) is designed for both end grain and side grain (bowl) use.



**Figure 45.** Swan Neck Hollowing Tools.

**H5954—Robert Sorby Stebcentre MT#2**  
 Razor sharp teeth bite into the workpiece for secure operation and the spring loaded center point controls the amount of drive or slip. This patented feature helps avoid the problem of "dig-in." Production turners can also load and unload their work while the lathe is still running!



**Figure 46.** Robert Sorby Stebcentre.

**Call 1-800-523-4777 To Order**



# SECTION 6: MAINTENANCE



## Schedule

For optimum performance from your machine, follow this maintenance schedule and refer to any specific instructions given in this section.

### Daily Check:

- Loose mounting bolts.
- Worn or damaged wires.
- Worn control panel buttons or dials.
- Any other unsafe condition.
- Lubricate tailstock, inboard tool rest, outboard tool rest, and spur and live centers.

### Weekly Maintenance:

- Clean off dust buildup.
- Clean and lubricate lathe bed and tailstock.

### Monthly Check:

- Belt tension, damage, or wear.
- Clean out dust buildup from inside belt pulley cavity and off of motor.

### Annually:

- Re-check the bedways for being level side-to-side and front-to-back.
- Lubricate the spindle bearings.

## Cleaning

Cleaning the Model G0694 is relatively easy. Vacuum excess wood chips and sawdust, and wipe off the remaining dust with a dry cloth. If any resin has built up, use a resin dissolving cleaner to remove it. Treat all unpainted cast iron and steel with a non-staining lubricant after cleaning.

## Lathe Bed

Protect the unpainted cast iron surfaces on the lathe bed by wiping the bed clean after every use—this ensures moisture from wood dust does not remain on bare metal surfaces.

Keep tables rust-free with regular applications of products like G96® Gun Treatment, SLIPIT®, or Boeshield® T-9.

## Spindle Bearing Lubrication

The tapered roller bearings on the G0694 spindle are pre-lubricated by the factory, but they will require re-lubrication over time. After the first year of use, clean and lubricate the spindle bearings, and thereafter repeat every two years. If the lathe is to be used daily, clean and re-lubricate bearings annually. The spindle bearings are located on the outboard and inboard side of the headstock.

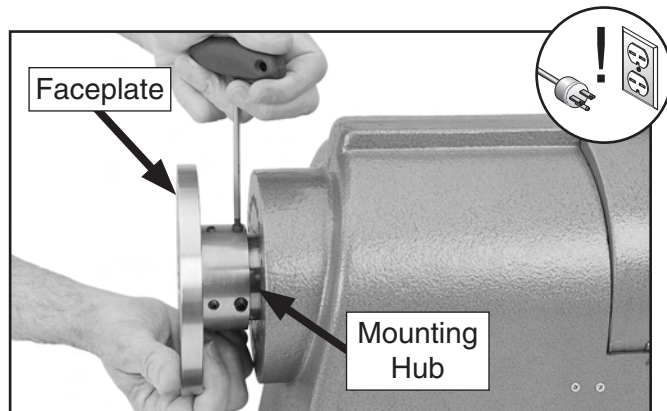
### Tools Needed:

Hex Wrench 3mm.....	1
Hex Wrench 4mm.....	1
Grease Gun.....	1
Needle Nose Adapter.....	1
Lithium Grease Tube.....	1



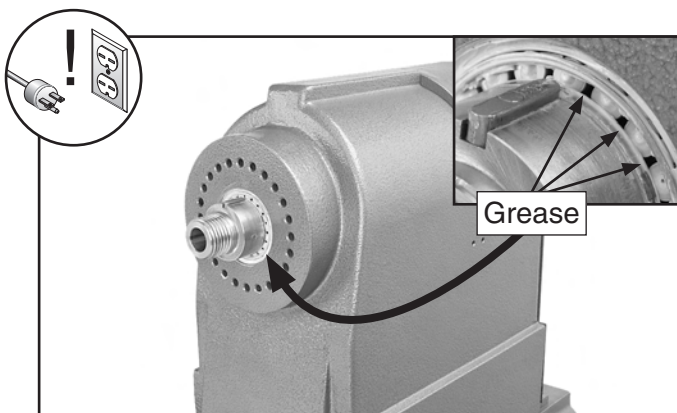
## Lubricating Spindle Bearings

1. DISCONNECT LATHE FROM POWER!
2. Loosen the set screws closest to the faceplate on the inboard mounting hub and remove the faceplate.
3. Loosen the set screws on the inner face of the mounting hub, as shown in **Figure 47**, then remove the mounting hub.



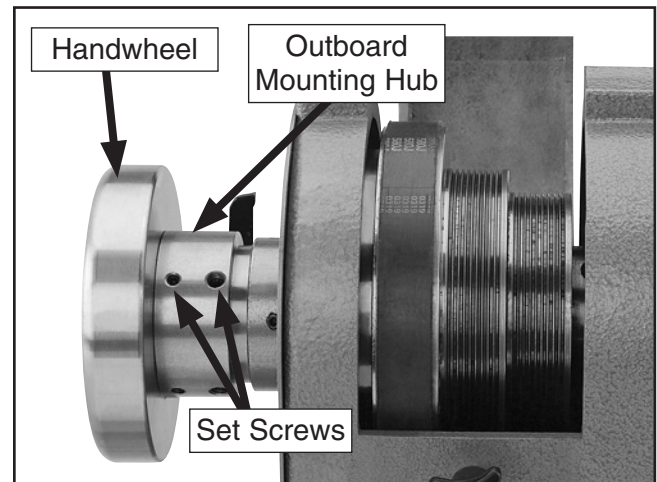
**Figure 47.** Loosening set screws on inboard mounting hub.

4. Place a few rags inside the headstock against the inner side of the bearing to catch any grease and debris for the next step.
5. Wipe down the outer race of the roller bearing with a clean cloth to remove any grime or debris.
6. Use a brush, mineral spirits, and an air gun to remove old grease from the bearing until it is clean and dry.
7. Use a grease gun with a needle adapter to insert lithium grease into the spaces between each of the rollers shown in **Figure 48**.



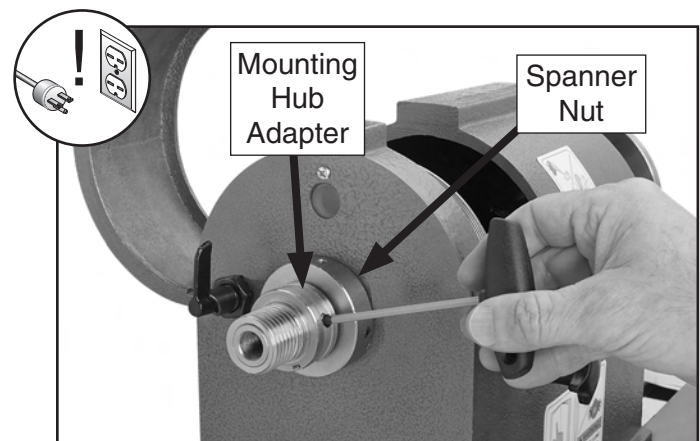
**Figure 48.** Location to add grease in between roller gaps.

8. Wipe the outer and inner race of the spindle bearing to remove extra grease.
9. Reinstall the inboard mounting hub and the faceplate.
10. Loosen the set screws closest to the handwheel on the outboard mounting hub (see **Figure 49**), unthread the handwheel, loosen the inner set of set screws, then remove the mounting hub.



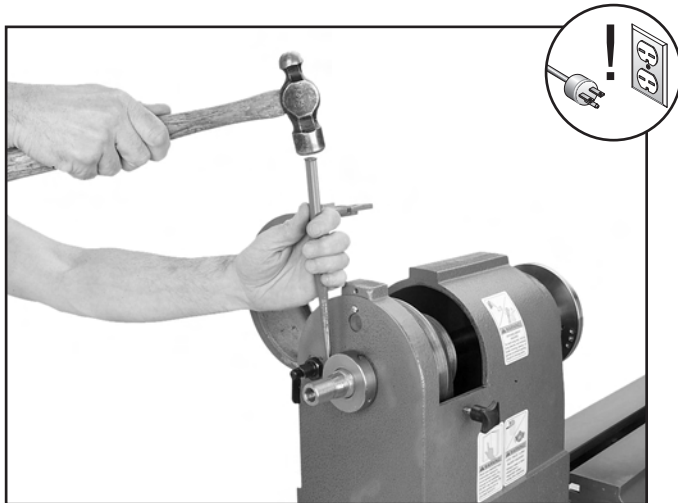
**Figure 49.** Outboard mounting hub.

11. Loosen the set screws on the outboard mounting hub adapter (see **Figure 50**). Unthread the mounting hub adapter using a spanner wrench with a 5mm pin, or by placing a 5mm diameter metal rod long enough to be used as a lever into the spanner nut hole.



**Figure 50.** Loosening set screw on outboard mounting hub adapter.

12. Loosen the set screws on the spanner nut, and use a spanner wrench or a hammer and a punch to loosen and remove the nut, as shown in **Figure 51**.



**Figure 51.** Unseating outboard spanner nut.

13. Repeat **Steps 3–7** on the outboard spindle bearing.
14. Reinstall the spanner nut. Only tighten the spanner nut far enough to achieve 0.001"–0.002" end play on the faceplate.
 

**Tip:** Use a dial indicator, as shown in **Figure 68** on **Page 45**, to measure end play on the faceplate.
15. When the correct amount of end play is reached, tighten the spanner nut an additional  $\frac{1}{8}$  turn to preload the bearings.
16. Reinstall the outboard mounting hub adapter, mounting hub, and handwheel in the reverse order.

## General Lubrication

An essential part of lubrication maintenance is cleaning the components before lubricating them.

This step is critical because dust and chips build up on lubricated components, which makes them hard to move. Simply adding more grease to built-up grime will not result in smooth moving parts.

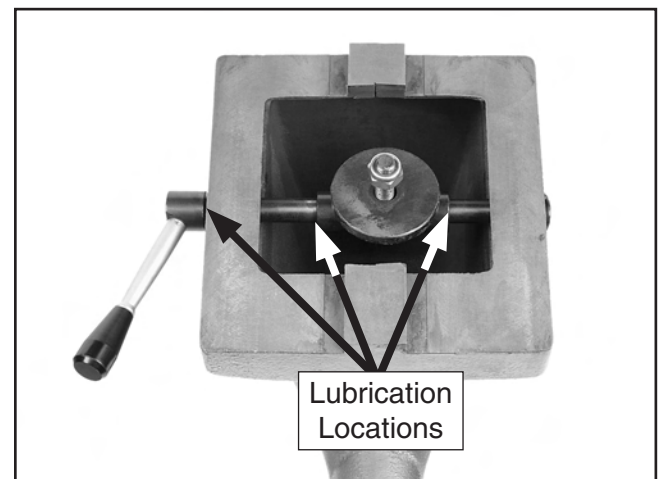
Clean the components in this section with mineral spirits and relubricate them.

The following are the main components that need to be lubricated:

- Tailstock
- Inboard Toolrest
- Outboard Toolrest
- Spur and Live Centers

### Tailstock

1. Loosen the tailstock lock lever, slide the tailstock off the bed, then turn it over.
2. Clean the shaft on the underside of the tailstock with mineral spirits and a rag.
3. Place a couple drops of light machine oil at each of the locations shown in **Figure 52**.



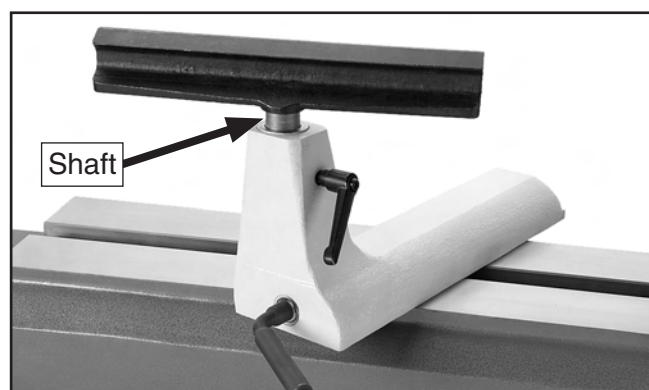
**Figure 52.** Locations to lubricate tailstock.

4. Pivot the tailstock lock lever and move the locking plate back and forth to distribute the oil.

5. Wipe off any excess oil and re-install the tailstock on the bed.
6. Loosen the quill lock handle and rotate the tailstock handwheel until the quill extends fully (approximately 3½").
7. Clean the outside and inside of the quill with a rag and mineral spirits.
8. Place a few drops of light machine oil on a rag and wipe down the inside and outside of the quill so only a minimal amount of oil remains.
9. Return the quill to the prior position.

### Inboard Tool Rest

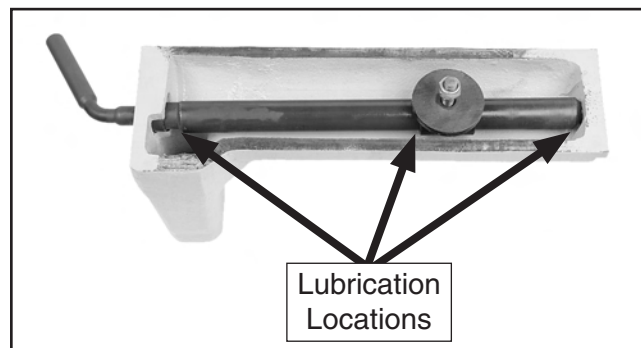
Clean the tool rest shaft (**Figure 53**) with mineral spirits and a rag, then wipe a thin coat of light machine oil onto the shaft to distribute the oil.



**Figure 53.** Location to lubricate tool rest.

**To lubricate the bottom of the tool rest holder:**

1. Loosen the tool rest lock lever, slide the tool rest holder off of the bed, then turn it over on a protected surface.
2. Clean the shaft on the underside of the tool rest holder with mineral spirits and a rag.
3. Place a couple drops of machine oil at each pivot point at the shaft ends and under the locking plate. Turn the tool rest lock lever and move the locking plate to distribute the oil (see **Figure 54**).

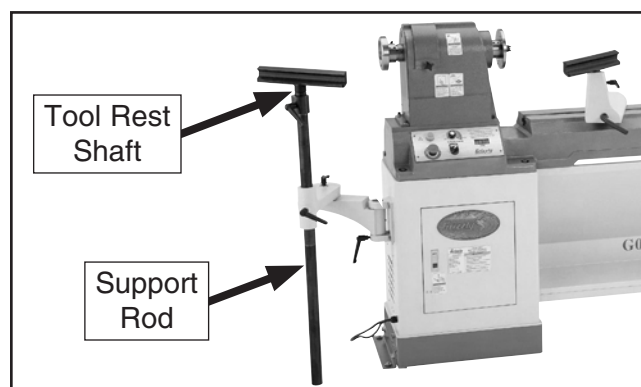


**Figure 54.** Locations to lubricate bottom of tool rest holder.

4. Re-install the tool rest holder on the bed.

### Outboard Tool Rest

1. Clean the outboard tool rest shaft and support rod with mineral spirits and a rag.
2. Place several drops of light machine oil on a rag and wipe it up and down the tool rest support rod (see **Figure 55**).



**Figure 55.** Locations to lubricate outboard tool rest.

3. Remove the outboard tool rest, wipe the shaft, then replace it.

### Spur and Live Centers

Remove the spur center from the headstock spindle and the live center from the tailstock (see **Page 22** and **23** for further details).

Clean each center with mineral spirits and a rag, then place several drops of light machine oil on a rag and wipe each center down.

Reinstall each center according to the instructions on **22** and **23**.





# SECTION 7: SERVICE

Review the troubleshooting and procedures in this section to fix or adjust your machine if a problem develops. If you need replacement parts or you are unsure of your repair skills, then feel free to call our Technical Support at (570) 546-9663.

## Troubleshooting



### Motor & Electrical

Symptom	Possible Cause	Possible Solution
Machine does not start or a breaker trips.	<ol style="list-style-type: none"> <li>Emergency stop push-button is engaged/faulty.</li> <li>Motor ON button at fault.</li> <li>Power supply switched OFF or at fault.</li> <li>Plug/receptacle at fault/wired wrong.</li> <li>Motor connection wired incorrectly.</li> <li>Spindle direction switch is at fault.</li> <li>Speed dial is at fault.</li> <li>Wiring is open/has high resistance.</li> <li>Inverter at fault.</li> <li>Motor is at fault.</li> </ol>	<ol style="list-style-type: none"> <li>Rotate button to reset/replace it.</li> <li>Replace button.</li> <li>Ensure power supply is on/has correct voltage.</li> <li>Test for good contacts; correct the wiring.</li> <li>Correct motor wiring connections.</li> <li>Replace faulty spindle direction dial.</li> <li>Replace bad speed dial.</li> <li>Check for broken wires or disconnected/corroded connections, and repair/replace as necessary.</li> <li>Inspect inverter; replace if faulty.</li> <li>Test/repair/replace.</li> </ol>
Machine stalls or is underpowered.	<ol style="list-style-type: none"> <li>Feed rate/cutting speed incorrect or task.</li> <li>Workpiece material not suitable for machine.</li> <li>Belt slipping.</li> <li>Motor wired incorrectly.</li> <li>Plug/receptacle at fault.</li> <li>Pulley slipping on shaft.</li> <li>Motor bearings are at fault.</li> <li>Machine is undersized for the task.</li> <li>Motor has overheated.</li> <li>Speed switch at fault.</li> <li>Motor is at fault.</li> </ol>	<ol style="list-style-type: none"> <li>Decrease feed rate/increase speed.</li> <li>Only cut wood/ensure moisture is below 20%.</li> <li>Re-tension or replace bad belt (see <b>Page 42</b>).</li> <li>Wire motor correctly (see <b>Page 48</b>).</li> <li>Test for good contacts/correct wiring.</li> <li>Replace loose pulley/shaft.</li> <li>Test/repair/replace.</li> <li>Use sharp lathe bits and chisels; reduce the feed rate/depth of cut.</li> <li>Clean off motor, let cool, and reduce workload.</li> <li>Replace bad speed switch.</li> <li>Test/repair/replace.</li> </ol>
Machine has vibration or noisy operation.	<ol style="list-style-type: none"> <li>Motor or component is loose.</li> <li>Belt worn or loose.</li> <li>Motor fan is rubbing on fan cover.</li> <li>Pulley is loose.</li> <li>Machine is incorrectly mounted or sits unevenly on floor.</li> <li>Motor mount loose/broken.</li> <li>Workpiece, center, or faceplate is at fault or mounted incorrectly.</li> <li>Motor bearings are at fault.</li> </ol>	<ol style="list-style-type: none"> <li>Inspect/replace stripped or damaged bolts/nuts, and re-tighten with thread locking fluid.</li> <li>Inspect/replace belt (see <b>Pages 41–42</b>).</li> <li>Replace dented fan cover; replace loose/damaged fan.</li> <li>Replace shaft, pulley, setscrew, and key as required.</li> <li>Tighten/replace anchor studs in floor; relocate/shim machine.</li> <li>Tighten/replace.</li> <li>Center workpiece on faceplate; reduce RPM; replace defective center or faceplate.</li> <li>Test by rotating shaft; rotational grinding/loose shaft requires bearing replacement.</li> </ol>



# Wood Lathe Operation



Symptom	Possible Cause	Possible Solution
Vibration noise while machine is running; noise changes when speed is changed.	<ol style="list-style-type: none"> <li>1. Belt cover loose.</li> <li>2. Dented fan cover on motor.</li> <li>3. Worn or damaged spindle bearing(s).</li> <li>4. Loose pulley.</li> </ol>	<ol style="list-style-type: none"> <li>1. Tighten belt cover lock knob; if necessary install a soft, vibration dampening material between the belt cover and the headstock casting.</li> <li>2. Replace or adjust fan cover. Inspect motor fan and replace if damaged.</li> <li>3. Replace spindle bearing(s).</li> <li>4. Adjust pulley.</li> </ol>
Excessive vibration.	<ol style="list-style-type: none"> <li>1. Workpiece mounted incorrectly.</li> <li>2. Workpiece warped, out of round, or is flawed.</li> <li>3. Spindle speed is set too fast for mounted workpiece.</li> <li>4. Lathe is resting on an uneven surface.</li> <li>5. Motor mount bolts are loose.</li> <li>6. Belt is worn or damaged.</li> <li>7. Worn or damaged spindle bearing(s).</li> </ol>	<ol style="list-style-type: none"> <li>1. Re-mount workpiece, making sure that centers are embedded in true center of workpiece.</li> <li>2. Cut workpiece to correct, or use a different workpiece.</li> <li>3. Reduce the spindle speed.</li> <li>4. Shim cabinets and mounting flanges to remove any wobbles present in the stand.</li> <li>5. Tighten motor mount bolts.</li> <li>6. Replace belt (see <b>Page 42</b>).</li> <li>7. Replace spindle bearings.</li> </ol>
Chisels grab or dig into workpiece.	<ol style="list-style-type: none"> <li>1. Tool rest set too low or chisel angle incorrect.</li> <li>2. Tool rest set too far from workpiece.</li> <li>3. Wrong chisel/tool being used.</li> <li>4. Chisel/tool dull.</li> </ol>	<ol style="list-style-type: none"> <li>1. Set tool rest higher. See <b>Pages 20–21</b> for how to properly set the tool rest height and angle.</li> <li>2. Move the tool rest closer to the workpiece. See <b>Pages 20–21</b> for the proper workpiece/tool rest clearance.</li> <li>3. Use the correct chisel/tool; educate yourself by reading books, trade magazines, or seeking help from an experienced lathe operator.</li> <li>4. Sharpen or replace the chisel/tool you are using.</li> </ol>
Bad surface finish.	<ol style="list-style-type: none"> <li>1. Wrong spindle speed.</li> <li>2. Dull chisel or wrong chisel being used for the operation.</li> <li>3. Loose workpiece.</li> </ol>	<ol style="list-style-type: none"> <li>1. Use trial-and-error to find a better spindle speed.</li> <li>2. Sharpen chisel or try a different chisel.</li> <li>3. Tighten workpiece.</li> </ol>
Tailstock moves.	<ol style="list-style-type: none"> <li>1. Tailstock mounting bolt loose.</li> <li>2. Bed surface is oily or greasy.</li> </ol>	<ol style="list-style-type: none"> <li>1. Tighten so lever locks at horizontal position.</li> <li>2. Clean bedway surface to remove excess oil/grease.</li> </ol>
Cannot remove tapered tool from tailstock barrel.	<ol style="list-style-type: none"> <li>1. Tailstock quill had not retracted all the way back into the tailstock.</li> <li>2. Debris was not removed from taper before inserting into barrel.</li> </ol>	<ol style="list-style-type: none"> <li>1. Turn the quill handwheel until it forces taper out of barrel.</li> <li>2. Always make sure that taper surfaces are clean.</li> </ol>



# Belt Adjustment

For optimal power transmission from the motor to the spindle, the belt must be in good condition and properly tensioned. The belt should be checked for cracks, fraying and wear. Check belt tension every three months; more often if the lathe is used frequently.

## Checking Belt

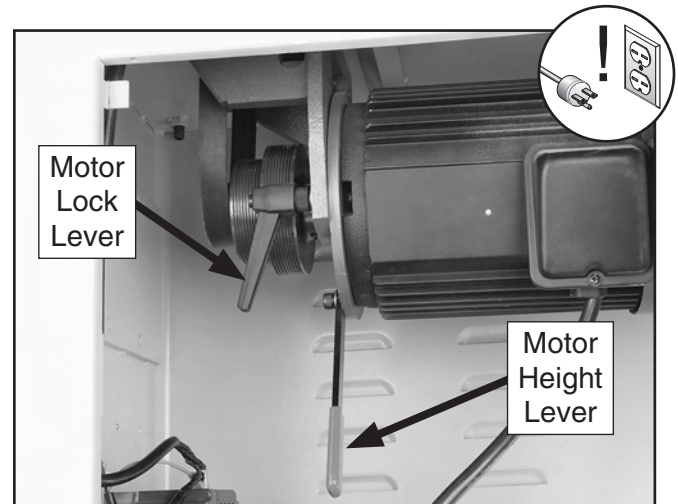
1. DISCONNECT LATHE FROM POWER!
2. Open the cabinet door.
3. Push the center of the belt. It should feel rigid to the touch with almost no deflection or play.

—If the belt is cracked, frayed or glazed, it should be replaced immediately. Proceed to **Changing Belt/Bearing Service** on **Page 42**.

—If there is deflection in the belt, proceed to the *Tensioning Belt* subsection.

## Tensioning Belt

1. DISCONNECT LATHE FROM POWER!
2. Loosen the motor lock lever shown in **Figure 56**, raise the motor up using the height lever, then let the motor hang down on its own weight to tension the belt.



**Figure 56.** Motor tension controls.

**Note:** *If the motor does not freely hang against the belt, you may have to manually push the height lever to tension the belt.*

3. Make sure the belt ribs fit in the pulley grooves.
4. Tighten the motor tension lock lever.
5. Close the cabinet door.

# Changing Belt/ Bearing Service

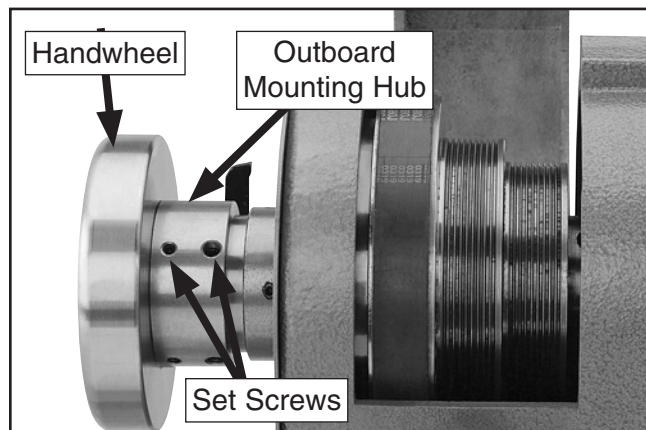
Removing the belt is a special procedure that should not be rushed. Only replace the belt if it is slipping/damaged or if you need to replace the spindle bearings.

For this procedure you will remove the handwheel and mounting hub, hub adapter, spanner nut, outboard spindle bearing, end plate and speed sensor. You will also need to reset the spindle bearing preload and reinstall all of the components. Set aside approximately two hours to perform this procedure.

Tools Needed	Qty
Another Person.....	1
Hex Wrench 3mm.....	1
Hex Wrench 4mm.....	1
Hammer.....	1
Punch.....	1
2x4 6" Long.....	1
White Lithium Grease.....	As Needed
Metal Rod 6" Long 5mm Diameter.....	2
Spanner Wrench with 5mm Pin (Optional).....	1
Dial Indicator with Magnetic Base.....	1

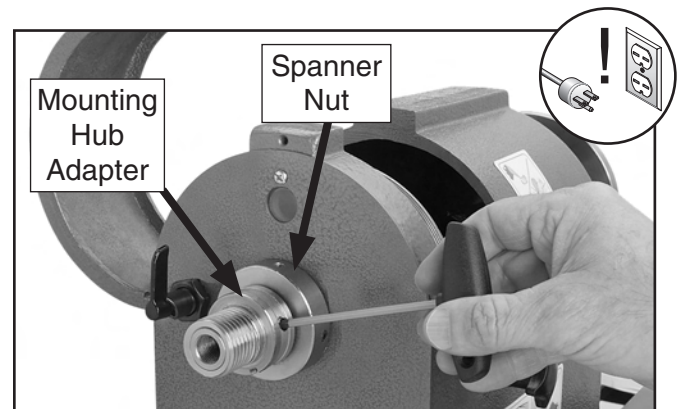
## To remove the existing belt and install a new belt:

1. DISCONNECT LATHE FROM POWER!
2. Loosen the outer set screws on the outboard mounting hub (see **Figure 57**), unthread the handwheel, loosen the inner set of set screws, then remove the mounting hub.



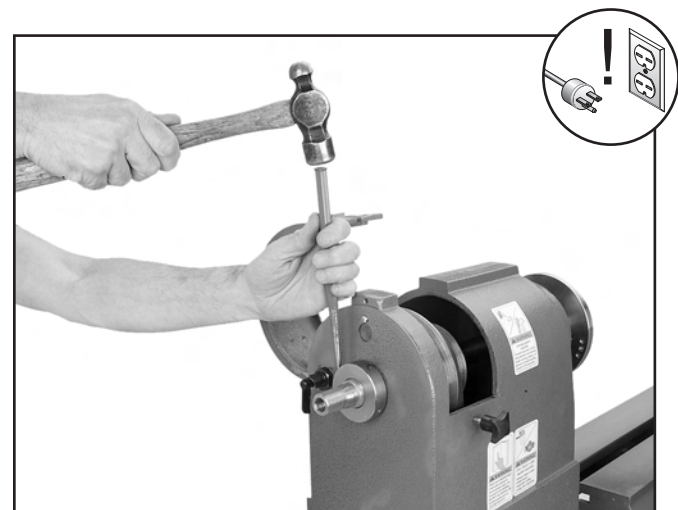
**Figure 57.** Outboard mounting hub location.

3. Loosen the set screws on the outboard mounting hub adapter (see **Figure 58**), place a hex wrench in one of the spanner nut set screws to hold the nut in place, then unthread the mounting hub adapter.



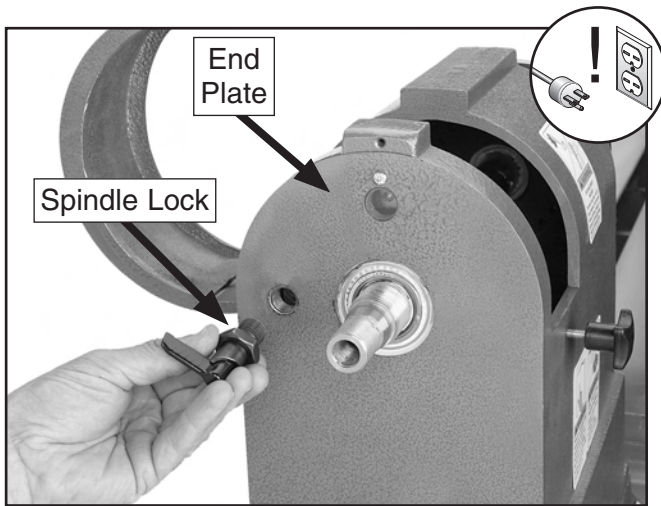
**Figure 58.** Loosening set screw on outboard mounting hub adapter.

4. Loosen the set screws on the spanner nut, use a hammer and a punch to knock it loose, as shown in **Figure 59**, then remove it.



**Figure 59.** Unseating outboard spanner nut.

5. Unthread the lock nut on the spindle lock mechanism, then remove the unit (see **Figure 60**).



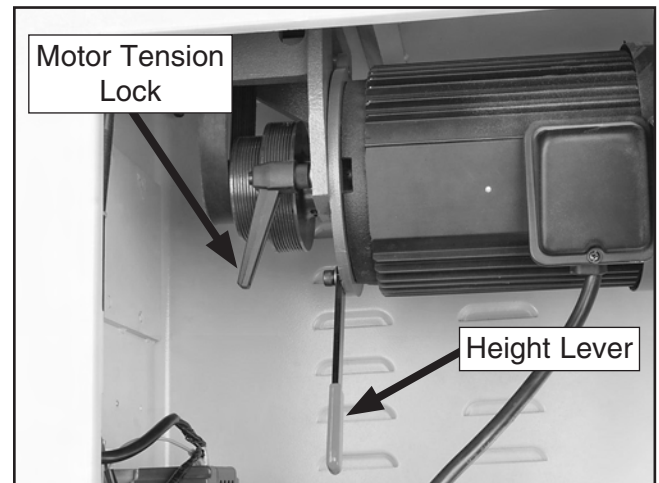
**Figure 60.** Removing spindle lock mechanism.

6. Remove the end plate, then open the belt cover.
7. Remove the Phillips head screws that secure the speed sensor (**Figure 61**), then reach inside the headstock and rest the sensor cord over the internal crossbar, or bring it outside the headstock so it is out of the way during the following steps.



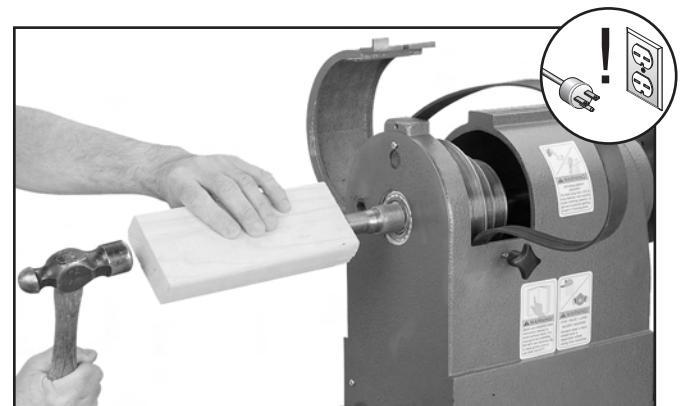
**Figure 61.** Removing speed sensor screws.

8. Loosen the motor tension lock (see **Figure 62**), raise the motor up as far as possible using the height lever, tighten the tension lock, then remove the belt from the motor pulley.



**Figure 62.** Motor tension controls.

9. While an assistant holds the inboard end of the spindle and pulls it toward the tailstock, use a hammer and 2x4 to drive the outboard end of the spindle toward the tailstock, as shown in **Figure 63**. This will expose the inboard spindle bearing.



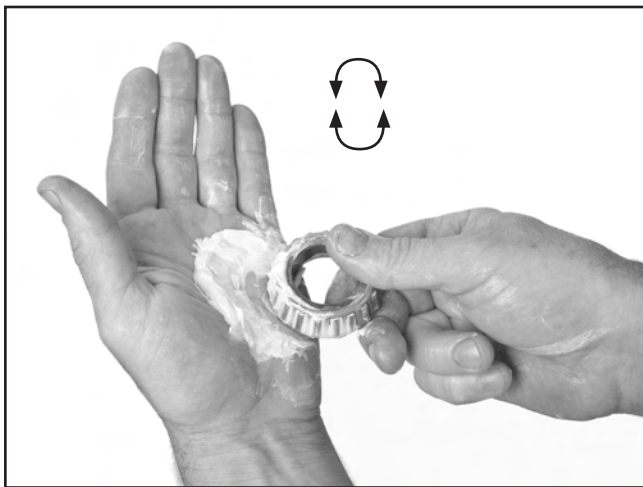
**Figure 63.** Loosening spindle.

10. Remove the belt from the spindle pulley.
11. Remove the outboard spindle bearing.
12. Inspect the inboard and outboard roller bearings for pitting, cracks or heavy wear. Replace them if either shows signs of serious wear.
13. Clean the spindle bearings using mineral spirits and compressed air.

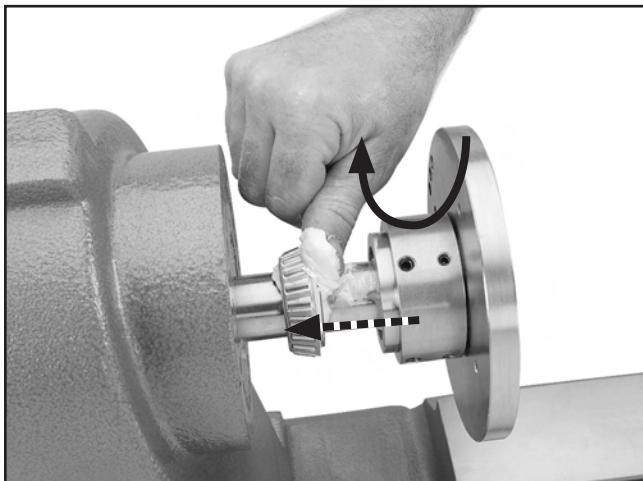
## NOTICE

Do not spin a spindle bearing while blowing it off with compressed air or it could fly apart.

14. Place a thick layer of grease on the bottom of your palm, and in a sweeping motion, use the large side of the bearing cage to scrape the grease off your palm and into the spaces between the rollers. Continue doing this while rotating the bearing 360° until the grease emerges from the other side of the bearing cage, as shown in **Figures 64–65**.

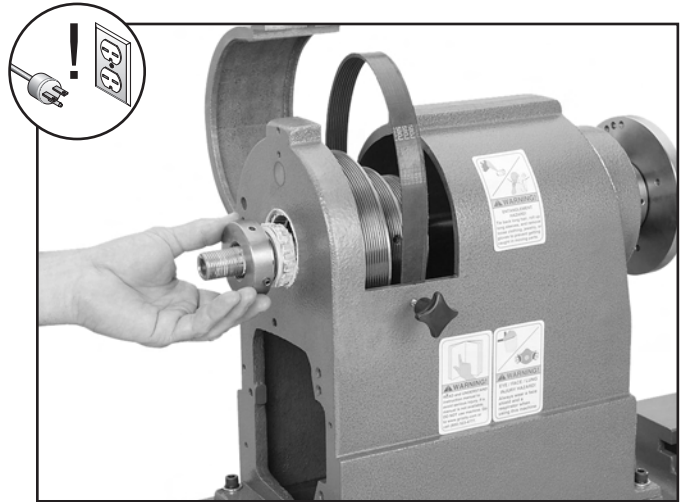


**Figure 64.** Packing outboard roller bearing with grease.



**Figure 65.** Packing inboard roller bearing with grease.

15. Place the belt around one of the pulley grooves. (Avoid getting grease on the belt or pulleys.)
16. Insert the spindle through the outboard end of the headstock, then slide the bearing you removed in **Step 11** onto the outboard spindle.
17. Thread the spanner nut (see **Figure 66**) onto the outboard spindle until it contacts the outboard bearing.



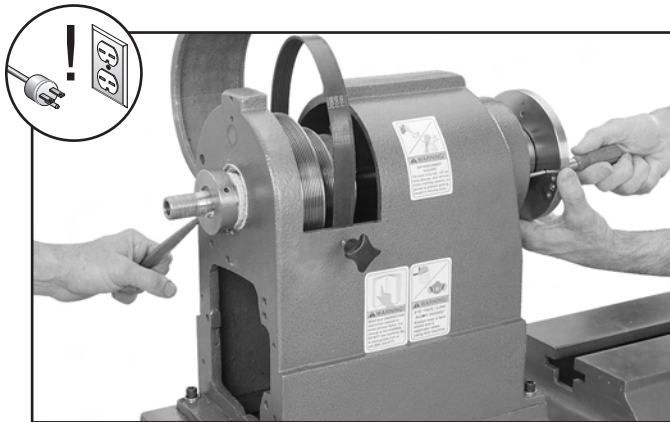
**Figure 66.** Outboard bearing and spanner nut reinstalled.

18. Insert a 5mm diameter metal rod through the faceplate into one of the indexing holes on the headstock to keep the spindle from moving during the next step.

## NOTICE

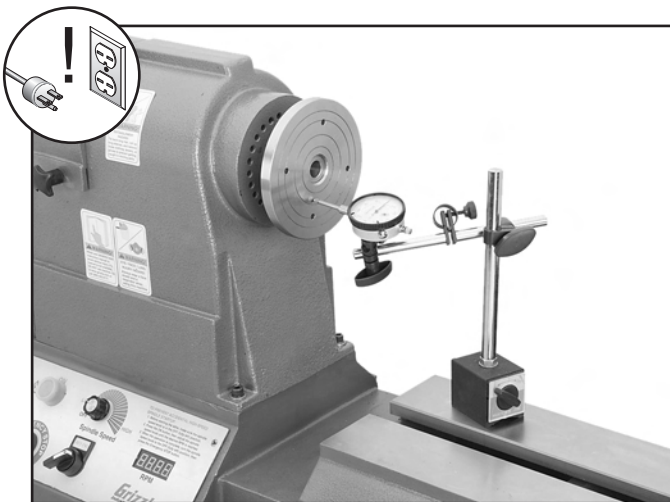
For the next step you will use the spanner nut to press the bearing back onto the shaft. Do not keep tightening the spanner nut once the end place is removed from the spindle or you will destroy the bearings!

19. While an assistant holds the metal rod through the faceplate to prevent the spindle from turning in the headstock, tighten the spanner nut until it is snug and seat the outboard bearing, as shown in **Figure 67**.



**Figure 67.** Seating outboard roller bearing.

20. Set up a dial indicator, as shown in **Figure 68**, and while holding the spanner nut with a leather glove, push and pull it toward the tailstock to determine the amount of end play. The correct amount of end play is 0.001"–0.002".

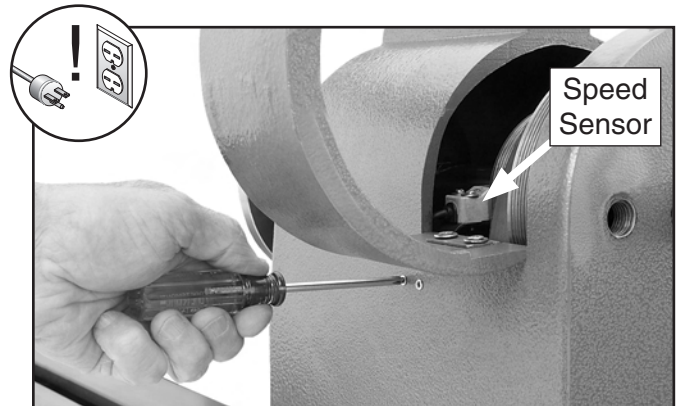


**Figure 68.** Using a dial indicator to measure end play.

21. Loosen or tighten the spanner nut until end play is 0.001"–0.002", tighten the spanner nut an additional  $\frac{1}{8}$  turn to preload the bearings.

22. Put on a pair of leather gloves and remove the spanner nut.
23. Reinstall the speed sensor with the screws you removed earlier (see **Figure 69**). Make sure the cord does not touch the pulley sheaves or hang down near them.

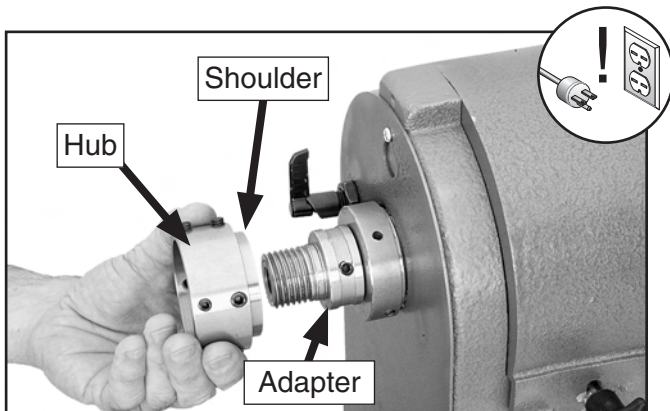
**Tip:** To avoid entangling the speed sensor cord in the pulleys, tie it onto the inboard side of the cross support bar inside the headstock.



**Figure 69.** Reinstalling speed sensor.

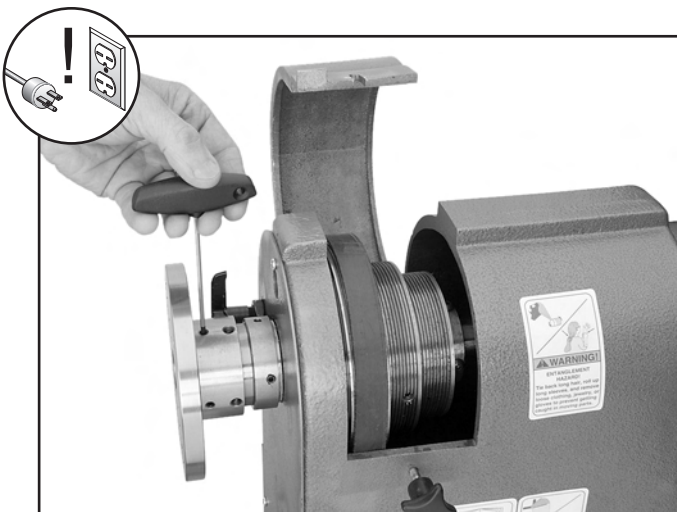
24. Replace the cover on the outboard end of the spindle and secure it with the spindle lock mechanism you removed in **Step 5**.
25. Thread the spanner nut fully onto the spindle, then secure it with the two set screws.
26. Thread the mounting hub adapter onto the spindle and tighten the three set screws.
27. Align the key in the adapter with the keyway in the outboard mounting hub.

28. Slide the mounting hub onto the adapter (see **Figure 70**), making sure the shoulder of the hub faces the headstock, then tighten the inner set screws on the hub.



**Figure 70.** Threading on mounting hub.

29. Thread the handwheel onto the mounting hub, then tighten the outer set screws on the mounting hub (see **Figure 71**).



**Figure 71.** Securing handwheel.

30. Reinstall the belt on the appropriate motor pulley groove.
31. Properly re-tension the belt (refer to *Tensioning Belt* on **Page 41** for detailed instructions).



# SECTION 8: WIRING

These pages are current at the time of printing. However, in the spirit of improvement, we may make changes to the electrical systems of future machines. Study this section carefully. If there are differences between your machine and what is shown in this section, call Technical Support at (570) 546-9663 for assistance BEFORE making any changes to the wiring on your machine.

## WARNING
















### Wiring Safety Instructions

1. **SHOCK HAZARD.** Working on wiring that is connected to a power source is extremely dangerous. Touching electrified parts will result in personal injury including but not limited to severe burns, electrocution, or death. Disconnect the power from the machine before servicing electrical components!
2. **QUALIFIED ELECTRICIAN.** Due to the inherent hazards of electricity, only a qualified electrician should perform wiring tasks on this machine. If you are not a qualified electrician, get help from one before attempting any kind of wiring job.
3. **WIRE CONNECTIONS.** All connections must be tight to prevent wires from loosening during machine operation. Double-check all wires disconnected or connected during any wiring task to ensure tight connections.
4. **WIRE/COMPONENT DAMAGE.** Damaged wires or components increase the risk of serious personal injury, fire, or machine damage. If you notice that any wires or components are damaged while performing a wiring task, replace those wires or components before completing the task.
5. **MODIFICATIONS.** Using aftermarket parts or modifying the wiring beyond what is shown in the diagram may lead to unpredictable results, including serious injury or fire.
6. **MOTOR WIRING.** The motor wiring shown in these diagrams is current at the time of printing, but it may not match your machine. Always use the wiring diagram inside the motor junction box.
7. **CAPACITORS/INVERTERS.** Some capacitors and power inverters store an electrical charge for up to 10 minutes after being disconnected from the power source. To reduce the risk of being shocked, wait at least this long before working on capacitors.
8. **CIRCUIT REQUIREMENTS.** You MUST follow the requirements at the beginning of this manual when connecting your machine to a power source.
9. **EXPERIENCING DIFFICULTIES.** If you are experiencing difficulties understanding the information included in this section, contact our Technical Support at (570) 546-9663.

#### NOTICE

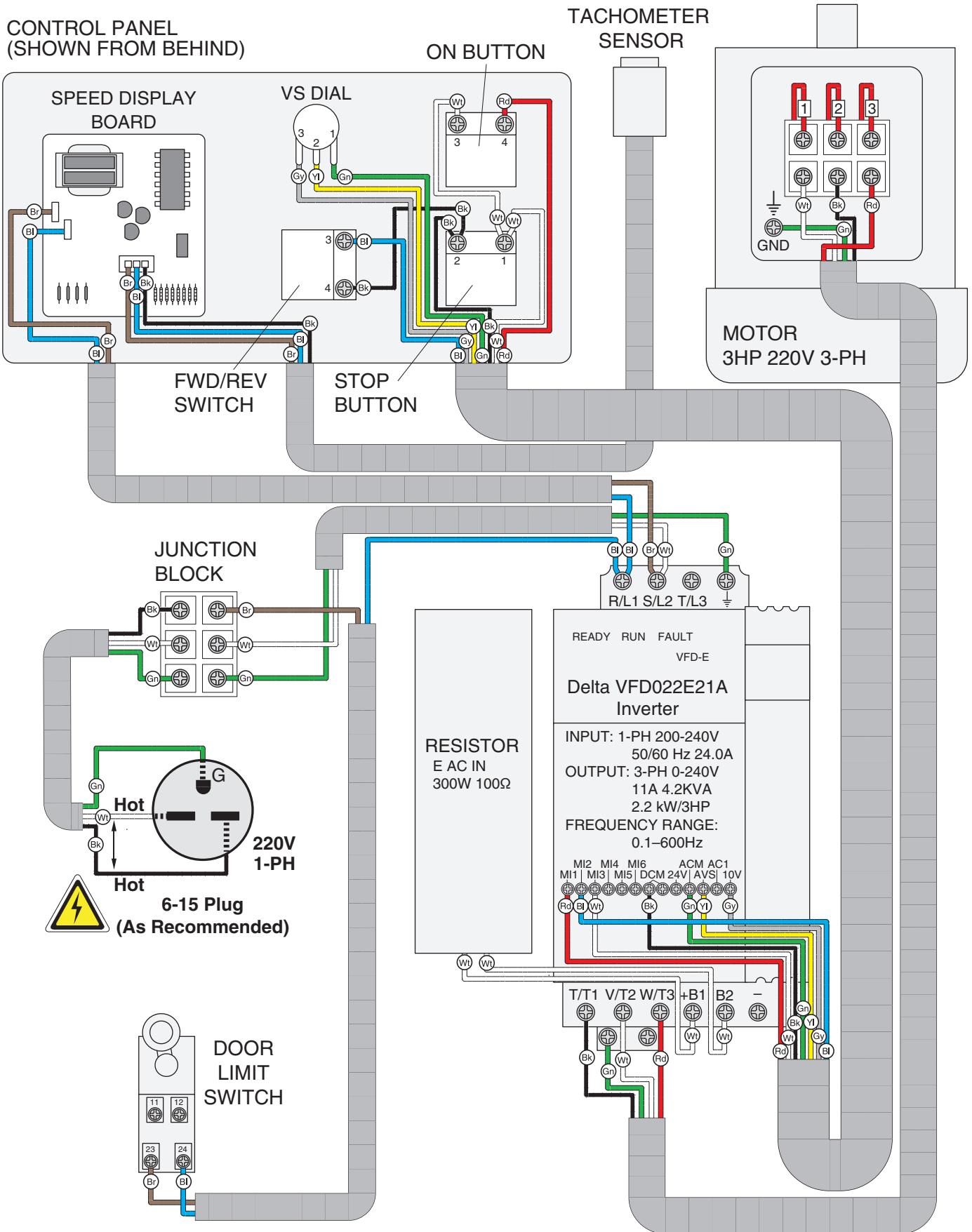
The photos and diagrams included in this section are best viewed in color. You can view these pages in color at [www.grizzly.com](http://www.grizzly.com).

#### COLOR KEY

BLACK 	BLUE 	YELLOW 	LIGHT BLUE 
WHITE 	BROWN 	YELLOW GREEN 	BLUE WHITE 
GREEN 	GRAY 	PURPLE 	TURQUOISE 
RED 	ORANGE 	PINK 	



# Wiring Diagram



# Electrical Components



Figure 72. Control panel wiring.

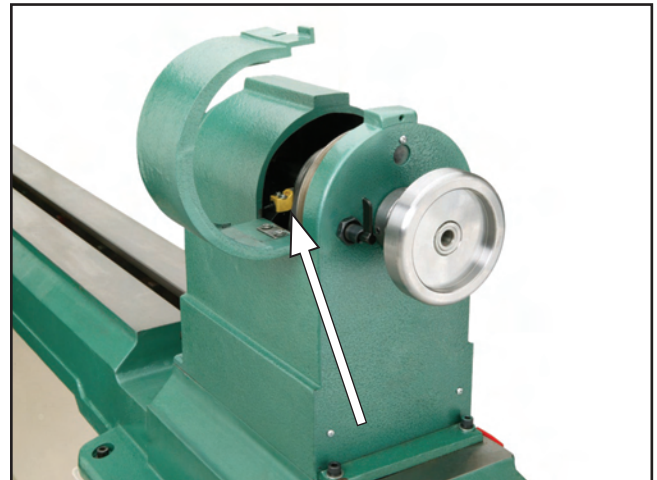


Figure 73. Tachometer sensor location.

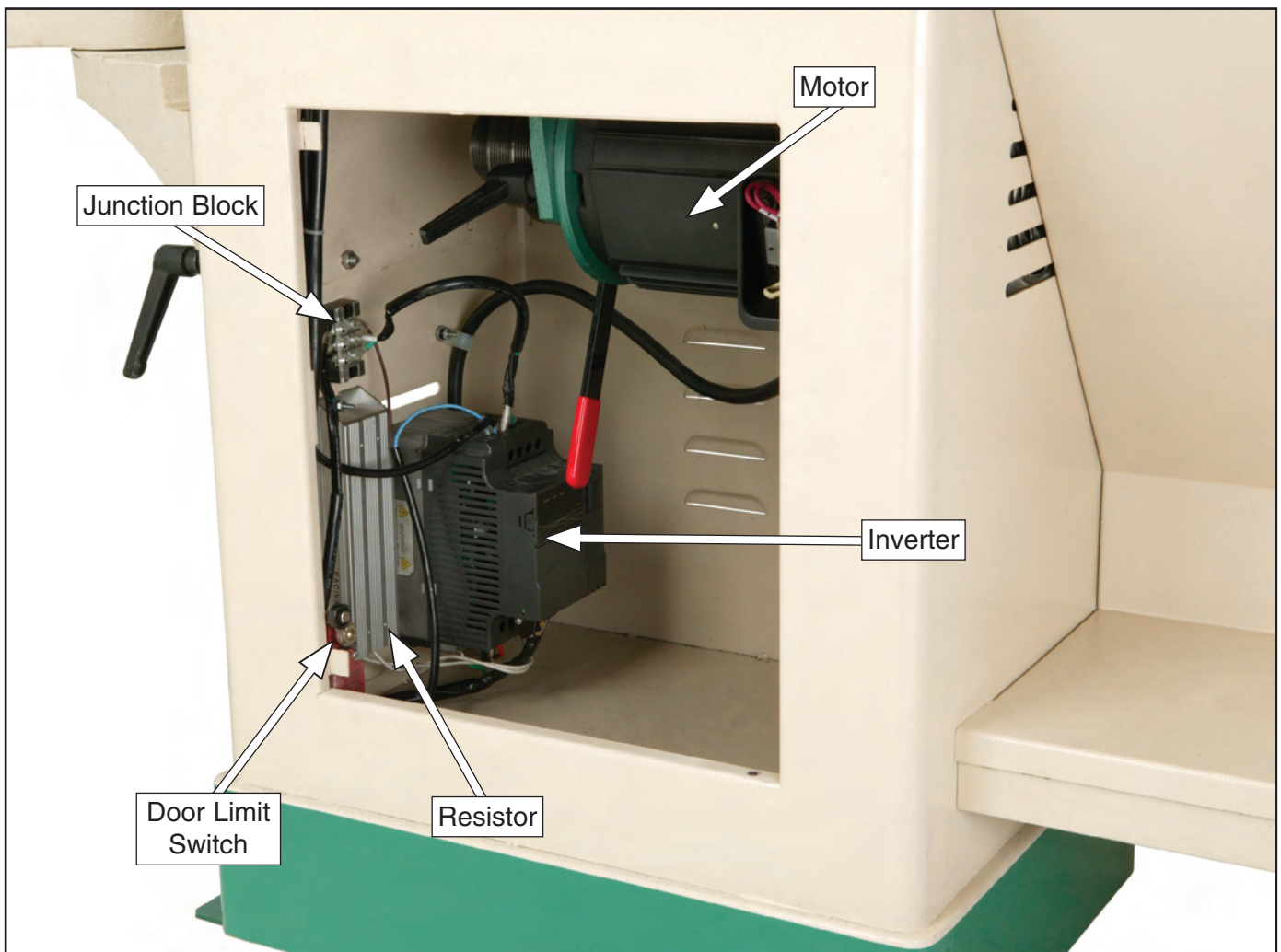
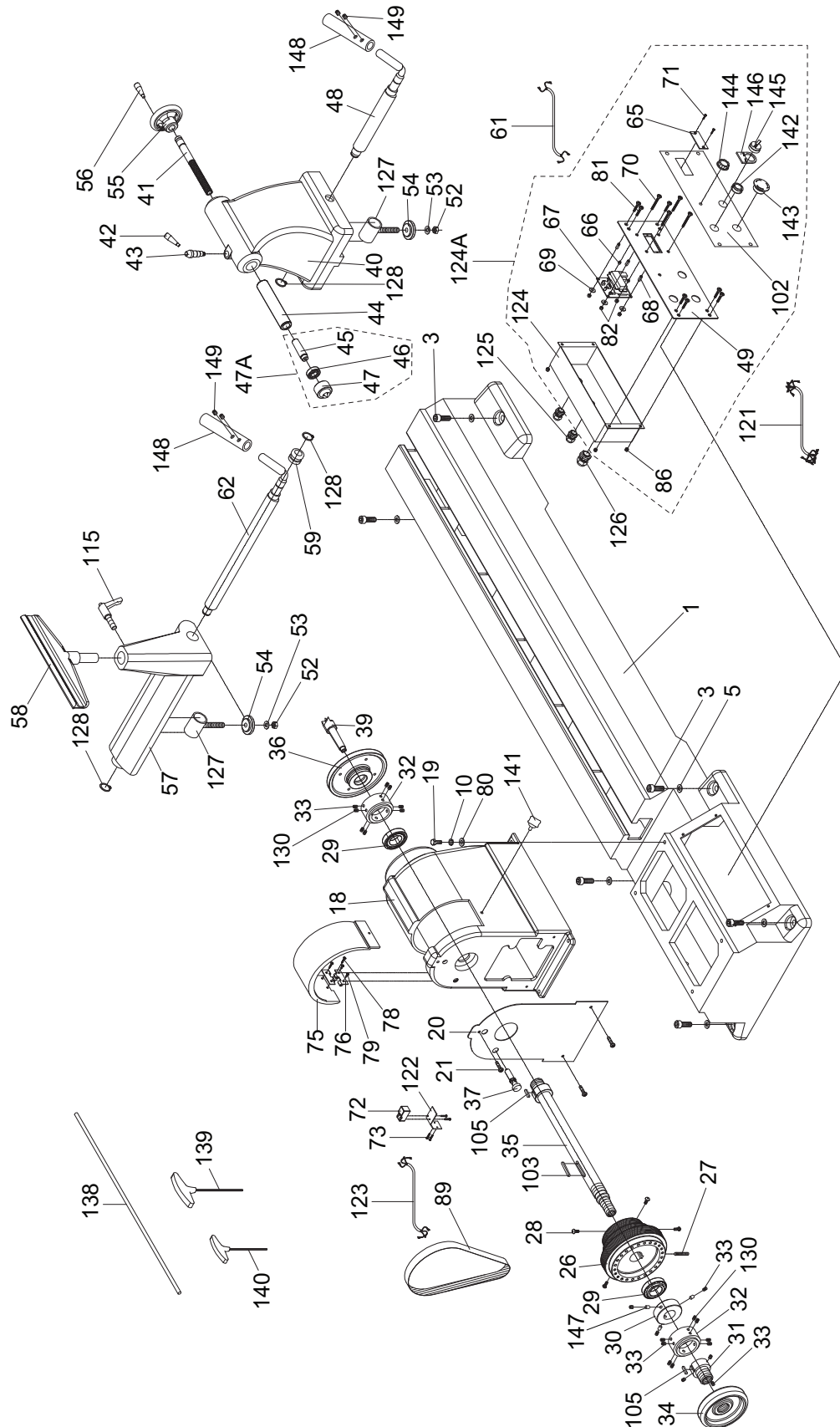


Figure 74. Wiring component location.

# SECTION 9: PARTS

## Lathe Breakdown



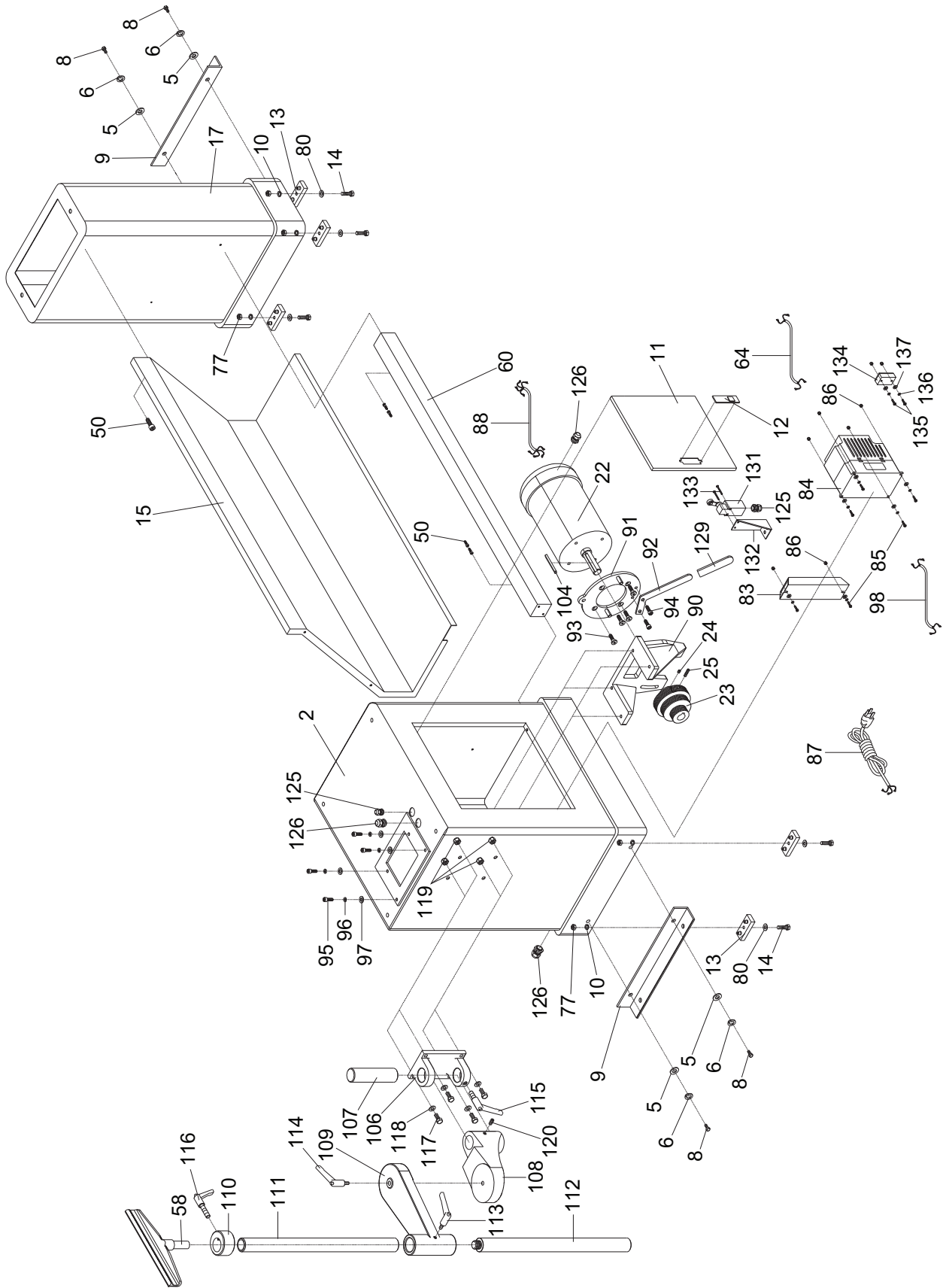
# Lathe Parts List

REF	PART #	DESCRIPTION
1	P0694001	BED
3	PB101	HEX BOLT 7/16-14 X 1-1/2
5	PLW05M	LOCK WASHER 12MM
10	PLW01	LOCK WASHER 5/16
18	P0694018	HEAD STOCK
19	PB12	HEX BOLT 5/16-18 X 1-1/4
20	P0694020	BELT WHEEL COVER
21	PS114M	PHLP HD SCR 10-24 X 5/16
26	P0694026	PULLEY 3-STEP J9 SHEAVES
27	PSS44M	SET SCREW M8-1.25 X 40
28	PS11M	PHLP HD SCR M6-1 X 16
29	P0694029	TAPERED BEARING LM67048/10
30	P0694030	LOCK COLLAR
31	P0694031	SPINDLE ADAPTER
32	P0694032	SHAFT JOINT
33	PSS11	SET SCREW 1/4-20 X 1/4
34	P0694034	SPINDLE HANDWHEEL
35	P0694035	SPINDLE
36	P0694036	FACE PLATE 1-1/4 X 8 TPI
37	P0694037	LOCK SET
39	P0694039	SPUR CENTER
40	P0694040	TAILSTOCK BASE
41	P0694041	TAILSTOCK LEADSCREW
42	P0694042	SHORT HANDLE
43	P0694043	CAM SPINDLE
44	P0694044	TAILSTOCK QUILL
45	P0694045	LIVE CENTER SHAFT
46	P6002ZZ	BALL BEARING 6002ZZ
47	P0694047	LIVE CENTER HEAD
47A	P0694047A	LIVE CENTER ASSY
48	P0694048	TAILSTOCK LOCK SHAFT
49	P0694049	CONTROL PANEL FACEPLATE
52	PLN09M	LOCK NUT M12-1.75
53	PW01	FLAT WASHER 1/2
54	P0694054	SLIDE PLATE
55	P0694055	HANDWHEEL
56	P0694056	HANDWHEEL HANDLE
57	P0694057	TOOL REST BASE
58	P0694058	TOOL REST
59	P0694059	TUBE
61	P0694061	DIGITAL DISPLAY CORD 2W 18AWG
62	P0694062	TOOL REST LOCK SHAFT
65	P0694065	ACRYLIC BOARD

REF	PART #	DESCRIPTION
66	P0694066	SPACING COLLAR
67	P0694067	TRANSFORMER
68	P0694068	SPACER
69	P0694069	FIBER WASHER 12MM
70	PFH34	FLAT HD SCR 5-40 X 1
71	PFH33	FLAT HD SCR 5-40 X 3/4
72	P0694072	TACH SENSOR BAKS DA-1805NO
73	PS13M	PHLP HD SCR M3-.5 X 20
75	P0694075	UPPER COVER
76	P0694076	HINGE ASSEMBLY W/O SCREWS
78	PFH35	FLAT HD SCR 10-24 X 5/16
79	PFH26	FLAT HD SCR 10-24 X 1/4
80	PW07	FLAT WASHER 5/16
81	PFH36	FLAT HD SCR 10-24 X 5/8
82	PN28	HEX NUT 5-40
86	PN07	HEX NUT 10-24
89	P0694089	RIBBED V-BELT 580J9
102	P0694102	FACEPLATE LABEL
103	PK118M	KEY 8 X 7 X 50
105	PK14M	KEY 5 X 5 X 18
115	P0694115	ADJUST HANDLE M12-1.75 X 20
121	P0694121	CTRL PANEL CORD 8 WIRE 18AWG
122	P0694122	TACH SENSOR BRACKET
123	P0694123	TACH SENSOR CORD 3W 24AWG
124	P0694124	SWITCH BOX
124A	P0694124A	COMPLETE SWITCH BOX ASSY
125	P0694125	LT STRAIN RELIEF PG11
126	P0694126	LT STRAIN RELIEF PG13.5
127	P0694127	RING SHAFT
128	PR08M	EXT RETAINING RING 19MM
130	PSS17	SET SCREW 5/16-18 X 5/16
138	P0694138	PUSH ROD 8 X 600MM
139	P0694139	T-WRENCH 4MM X 100L
140	P0694140	T-WRENCH 3MM X 100L
141	P0694141	THUMB SCREW 1/4-20 X 5/8
142	P0694142	GO BUTTON (GREEN)
143	P0694143	STOP BUTTON (RED)
144	P0694144	SPEED DIAL
145	P0694145	FWD/REV KNOB
146	P0694146	FWD/REV PLATE
147	P0694147	COPPER SLUG 5 X 8MM
148	P0694148	LOCK SHAFT EXTENSION
149	PSS07M	SET SCREW M5-.8 X 5



# Stand Breakdown



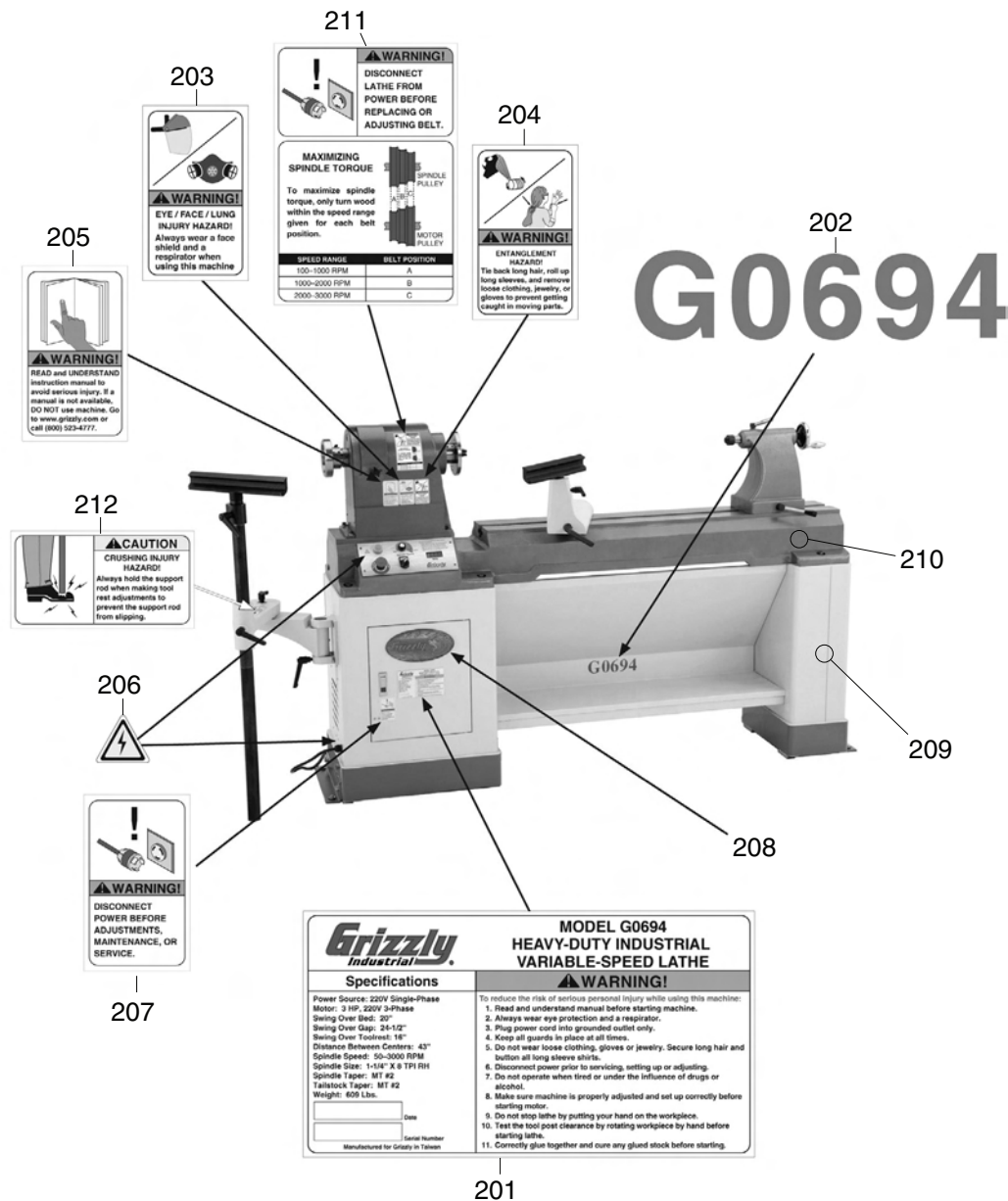
# Stand Parts List

REF	PART #	DESCRIPTION
2	P0694002	LEFT STAND (CABINET)
5	PLW05M	LOCK WASHER 12MM
6	PLW05M	LOCK WASHER 12MM
8	PB90	HEX BOLT 7/16-14 X 1-1/4
9	P0694009	L-BRACKET
10	PLW01	LOCK WASHER 5/16
11	P0694011	DOOR
12	P0694012	STAND ACCESS HANDLE
13	P0694013	RUBBER FOOT
14	PB32	HEX BOLT 5/16-18 X 5/8
15	P0694015	PARTITION BOARD
17	P0694017	RIGHT STAND
22	P0694022	MOTOR
23	P0694023	MOTOR PULLEY
24	PSS20M	SET SCREW M8-1.25 X 8
25	PSS19M	SET SCREW M8-1.25 X 30
50	PCAP41	CAP SCREW 10-24 X 1/2
58	P0694058	TOOL REST
60	P0694060	L-BRACKET
64	P0694064	LIMIT SWITCH CORD 2W 18AWG
77	PN02	HEX NUT 5/16-18
80	PW07	FLAT WASHER 5/16
83	P0694083	RESISTOR EACIN 300W 100 OHMS
84	P0694084	INVERTER DELTA VFD-E 022E21A
85	PS08	PHLP HD SCR 10-24 X 3/4
86	PN07	HEX NUT 10-24
87	P0694087	POWER CORD 3 WIRE 14AWG
88	P0694088	MOTOR CORD 4 WIRE 14AWG
90	P0694090	MOTOR BRACKET
91	P0694091	MOTOR MOUNT PLATE
92	P0694092	BELT TENSION HANDLE
93	PFH69M	FLAT HD CAP SCR M8-1.25 X 20

REF	PART #	DESCRIPTION
94	PCAP100M	CAP SCREW M8-1.25 X 15
95	PCAP31M	CAP SCREW M8-1.25 X 25
96	PLW04	LOCK WASHER 3/8
97	PW02	FLAT WASHER 3/8
98	P0694098	INVERTER PWR CORD 2W 14AWG
104	P0694104	KEY 8 X 7 X 90
106	P0694106	OUTBOARD MOUNTING BRACKET
107	P0694107	OUTBOARD ARBOR SHAFT
108	P0694108	LOWER BRACKET
109	P0694109	UPPER BRACKET
110	P0694110	ARBOR SHAFT TUBE
111	P0694111	OUTBOARD LONG SHAFT
112	P0694112	OUTBOARD SHORT SHAFT
113	P0694113	ADJUST HANDLE M10-1.5 X 20
114	P0694114	ADJUST HANDLE M12-1.5 X 60
115	P0694115	ADJUST HANDLE M12-1.75 X 20
116	P0694116	ADJUST HANDLE M12-1.75 X 25
117	PB26M	HEX BOLT M8-1.25 X 30
118	PW01M	FLAT WASHER 8MM
119	PLN04M	LOCK NUT M8-1.25
120	PSS16M	SET SCREW M8-1.25 X 10
125	P0694125	LT STRAIN RELIEF PG11
126	P0694126	LT STRAIN RELIEF PG13.5
129	P0694129	RUBBER HANDLE COVER
131	P0694131	LMT SWITCH SHINOZAKI AZD-1004
132	P0694132	LIMIT SWITCH BRACKET
133	PS25M	PHLP HD SCR M4-.7 X 35
134	P0694134	TERMINAL 3-POST (W/COVER)
135	PS03	PHLP HD SCR 10-24 X 1
136	PW03	FLAT WASHER #10
137	PLW03	LOCK WASHER #10



# Labels & Cosmetics Breakdown



REF	PART #	DESCRIPTION
201	P0694201	G0694 MACHINE ID LABEL
202	P0694202	G0694 MODEL # LABEL
203	PLABEL-56	FACE SHIELD RESPIRATOR LABEL
204	PLABEL-55	ENTANGLEMENT LABEL
205	PLABEL-12A	READ MANUAL LABEL
206	PLABEL-14A	ELECTRICITY LABEL

REF	PART #	DESCRIPTION
207	PLABEL-63	DISCONNECT POWER LABEL
208	G8588	GRIZZLY NAMEPLATE-SMALL
209	PPAINT-1	"GRIZZLY GREEN" PAINT
210	PPAINT-11	"GRIZZLY PUTTY" PAINT
211	P0694211	BELT POSITION LABEL
212	P0694212	CRUSHING HAZARD LABEL

## WARNING

Safety labels warn about machine hazards and ways to prevent injury. The owner of this machine **MUST** maintain the original location and readability of the labels on the machine. If any label is removed or becomes unreadable, **REPLACE** that label before using the machine again. Contact Grizzly at (800) 523-4777 or [www.grizzly.com](http://www.grizzly.com) to order new labels.







# WARRANTY CARD

Name \_\_\_\_\_

Street \_\_\_\_\_

City \_\_\_\_\_ State \_\_\_\_\_ Zip \_\_\_\_\_

Phone # \_\_\_\_\_ Email \_\_\_\_\_ Invoice # \_\_\_\_\_

Model # \_\_\_\_\_ Order # \_\_\_\_\_ Serial # \_\_\_\_\_

The following information is given on a voluntary basis. It will be used for marketing purposes to help us develop better products and services. **Of course, all information is strictly confidential.**

1. How did you learn about us?

- Advertisement
- Card Deck
- Friend
- Website
- Catalog
- Other:

2. Which of the following magazines do you subscribe to?

- |   |  |   |
|---|--|---|
| <input type="checkbox"/> Cabinet Maker          | <input type="checkbox"/> Popular Mechanics   | <input type="checkbox"/> Today's Homeowner    |
| <input type="checkbox"/> Family Handyman        | <input type="checkbox"/> Popular Science     | <input type="checkbox"/> Wood                 |
| <input type="checkbox"/> Hand Loader            | <input type="checkbox"/> Popular Woodworking | <input type="checkbox"/> Wooden Boat          |
| <input type="checkbox"/> Handy                  | <input type="checkbox"/> Practical Homeowner | <input type="checkbox"/> Woodshop News        |
| <input type="checkbox"/> Home Shop Machinist    | <input type="checkbox"/> Precision Shooter   | <input type="checkbox"/> Woodsmith            |
| <input type="checkbox"/> Journal of Light Cont. | <input type="checkbox"/> Projects in Metal   | <input type="checkbox"/> Woodwork             |
| <input type="checkbox"/> Live Steam             | <input type="checkbox"/> RC Modeler          | <input type="checkbox"/> Woodworker West      |
| <input type="checkbox"/> Model Airplane News    | <input type="checkbox"/> Rifle               | <input type="checkbox"/> Woodworker's Journal |
| <input type="checkbox"/> Modeltec               | <input type="checkbox"/> Shop Notes          | <input type="checkbox"/> Other:               |
| <input type="checkbox"/> Old House Journal      | <input type="checkbox"/> Shotgun News        |   |

3. What is your annual household income?

- \$20,000-\$29,000
- \$30,000-\$39,000
- \$40,000-\$49,000
- \$50,000-\$59,000
- \$60,000-\$69,000
- \$70,000+

4. What is your age group?

- 20-29
- 30-39
- 40-49
- 50-59
- 60-69
- 70+

5. How long have you been a woodworker/metalworker?

- 0-2 Years
- 2-8 Years
- 8-20 Years
- 20+ Years

6. How many of your machines or tools are Grizzly?

- 0-2
- 3-5
- 6-9
- 10+

7. Do you think your machine represents a good value?  Yes  No

8. Would you recommend Grizzly Industrial to a friend?  Yes  No

9. Would you allow us to use your name as a reference for Grizzly customers in your area?  
**Note: We never use names more than 3 times.**  Yes  No

10. Comments: \_\_\_\_\_

---



---



---

CUT ALONG DOTTED LINE

FOLD ALONG DOTTED LINE

\_\_\_\_\_

\_\_\_\_\_

\_\_\_\_\_



Place  
Stamp  
Here



**GRIZZLY INDUSTRIAL, INC.**  
**P.O. BOX 2069**  
**BELLINGHAM, WA 98227-2069**



FOLD ALONG DOTTED LINE

Send a Grizzly Catalog to a friend:

Name _____
Street _____
City _____ State _____ Zip _____

TAPE ALONG EDGES--PLEASE DO NOT STAPLE

# WARRANTY AND RETURNS

---

Grizzly Industrial, Inc. warrants every product it sells for a period of **1 year** to the original purchaser from the date of purchase. This warranty does not apply to defects due directly or indirectly to misuse, abuse, negligence, accidents, repairs or alterations or lack of maintenance. This is Grizzly's sole written warranty and any and all warranties that may be implied by law, including any merchantability or fitness, for any particular purpose, are hereby limited to the duration of this written warranty. We do not warrant or represent that the merchandise complies with the provisions of any law or acts unless the manufacturer so warrants. In no event shall Grizzly's liability under this warranty exceed the purchase price paid for the product and any legal actions brought against Grizzly shall be tried in the State of Washington, County of Whatcom.

We shall in no event be liable for death, injuries to persons or property or for incidental, contingent, special, or consequential damages arising from the use of our products.

To take advantage of this warranty, contact us by mail or phone and give us all the details. We will then issue you a "Return Number," which must be clearly posted on the outside as well as the inside of the carton. We will not accept any item back without this number. Proof of purchase must accompany the merchandise.

The manufacturers reserve the right to change specifications at any time because they constantly strive to achieve better quality equipment. We make every effort to ensure that our products meet high quality and durability standards and we hope you never need to use this warranty.

Please feel free to write or call us if you have any questions about the machine or the manual.

Thank you again for your business and continued support. We hope to serve you again soon.

# *grizzly.com*<sup>®</sup>

**TOOL WEBSITE**

Buy Direct and Save with Grizzly<sup>®</sup> – Trusted, Proven and a Great Value!  
~Since 1983~

*Visit Our Website Today For  
Current Specials!*

**ORDER  
24 HOURS A DAY!  
1-800-523-4777**



## Free Manuals Download Website

<http://myh66.com>

<http://usermanuals.us>

<http://www.somanuals.com>

<http://www.4manuals.cc>

<http://www.manual-lib.com>

<http://www.404manual.com>

<http://www.luxmanual.com>

<http://aubethermostatmanual.com>

Golf course search by state

<http://golfingnear.com>

Email search by domain

<http://emailbydomain.com>

Auto manuals search

<http://auto.somanuals.com>

TV manuals search

<http://tv.somanuals.com>