

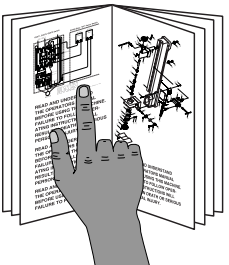

MODEL G0711 PLANISHING HAMMER INSTRUCTION SHEET



!WARNING
This machine can cause serious personal injury if used incorrectly. To reduce this risk, read and understand these instructions before using!

!WARNING
The Model G0711 has a maximum operating pressure of 100 PSI. Exceeding this pressure can lead to an explosion, which may cause serious personal injury!

!WARNING

  **EYE/EAR INJURY HAZARD!**
Wear safety glasses and hearing protection while using this tool!

 **INJURY HAZARD!**
Disconnect tool from air supply whenever servicing or adjusting machine!

 **CRUSHING HAZARD!**
Keep hands clear of hammer at all times!

Package Inventory

Foot Switch, Hose, and Hammer Assembly	1
C-Frame	1
Hammer Head w/Coil Spring.....	1
Die 7/8"-Shaft 1"-Radius	1
Die 7/8"-Shaft 2"-Radius	1
Die 7/8"-Shaft 3"-Radius	1
Hex Wrench 4mm.....	1
Hex Wrench 5mm.....	1

Specifications

Control Power.....	Pneumatic
Throat Depth	19 ⁵ / ₈ "
Hammer/Die Opening (Usable)	3/8"-1 1/4"
Maximum Opening (Loading/Unloading).....	4"
Maximum Workpiece Thickness.....	5/64" (2mm)
Hammer Speed	875-1350 BPM
Operating Air Pressure.....	50-100 PSI
Maximum Air Pressure	100 PSI
Air Inlet Size, Consumption	1/4" NPT, 4 CFM
Overall Dimensions	23" L x 5 1/2" W x 24" H
Weight	35 lbs

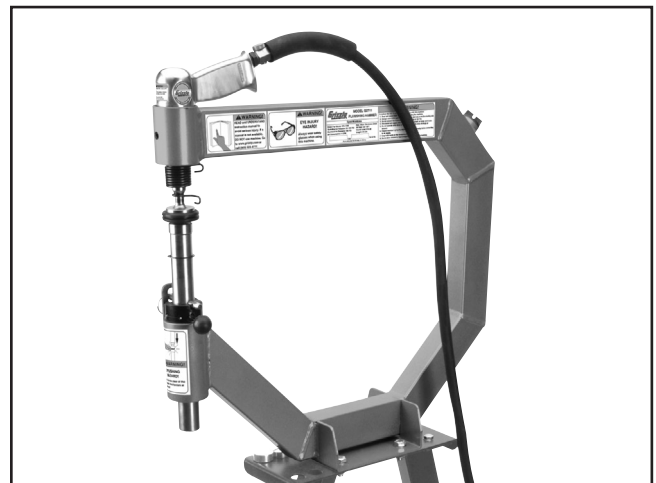

Figure 1. Model G0711 Planishing Hammer.

NOTICE
If you have any questions about this machine, please call or write us.

Grizzly Industrial, Inc.
1203 Lycoming Mall Circle
Muncy, PA 17756
Phone: (570) 546-9663
E-Mail: techsupport@grizzly.com

COPYRIGHT © AUGUST, 2010 BY GRIZZLY INDUSTRIAL, INC.
WARNING: NO PORTION OF THIS MANUAL MAY BE REPRODUCED IN ANY SHAPE OR FORM WITHOUT THE WRITTEN APPROVAL OF GRIZZLY INDUSTRIAL, INC.
(FOR MACHINES MFG. SINCE 7/10) #TR13227 PRINTED IN CHINA

WARNING

READ THIS MANUAL. This tool may cause personal injury if used incorrectly. Read this manual for proper safety and operating instructions to reduce this risk.

WEAR EYE PROTECTION. This tool may throw small fragments during operation, which may cause serious eye injury. Always wear ANSI approved safety glasses or face shield to reduce your risk from this hazard.

WEAR A RESPIRATOR. This tool may produce fine dust during operation, which can cause respiratory injury if inhaled. Always wear a respirator NIOSH approved for the type of material being processed.

WEAR HEARING PROTECTION. This tool is very loud during operation and can cause permanent hearing loss. To reduce your risk, always wear hearing protection, such as ear plugs or ear muffs while operating.

MAINTAIN SAFETY GUARDS. Your tool may be equipped with safety guards or other structural components designed to reduce the risk of injury during operation. Never modify or operate this tool with any guards or components removed or damaged.

KEEP CHILDREN AWAY. Children can injure themselves with this tool. Disconnect and lock the tool away when not in use.

AVOID ENTANGLEMENTS. Do not wear loose clothing, gloves, neckties, rings, bracelets, or other jewelry that may be caught in moving parts. Wear a hair covering to contain long hair.

USE CORRECT AIR PRESSURE. Exceeding the maximum PSI rating of this tool may cause unpredictable operation or bursting.

DISCONNECT AIR PRESSURE before servicing, changing accessories, or moving to another location. Never leave this tool unattended when connected to air.

SECURE TOOLING. Always verify tooling is secure before operation.

SHARP SURFACES. DO NOT place hands near the tooling surfaces when in operation.

REMOVE ADJUSTING KEYS AND WRENCHES AFTER USE. These tools become dangerous projectiles if left on the tool when it is started.

AVOID FLAMMABLES. Do not use around flammables that may be ignited by sparks.

SECURE WORK. Use clamps or a vise to hold work when practical. Otherwise, use both hands when shaping workpiece.

MAINTAIN TOOLS WITH CARE. Keep tools lubricated and clean for best and safest performance.

DO NOT FORCE TOOL. It will do the job better and safer at the rate for which it was designed.

CHECK FOR DAMAGED PARTS BEFORE USING. Check for binding and alignment of parts, broken parts, part mounting, loose bolts, and any other conditions that may affect operation. Repair or replace damaged parts before operating.

USE GOOD LIGHTING. Keep work area well lighted. Dark work areas increase risk of injury.

AVOID UNINTENTIONAL OPERATION. Always disconnect air when not in use.

USE RECOMMENDED ACCESSORIES. Using improper accessories may increase risk of injury.

NEVER ALLOW UNTRAINED USERS TO USE THIS TOOL WHILE UNSUPERVISED.

IF YOU ARE UNSURE OF THE INTENDED OPERATION, STOP USING TOOL. Seek formal training or research books or magazines that specialize in pneumatic tools.

BE AWARE OF HOSE LOCATION. Hoses can become a tripping hazard when laid across the floor in a disorganized fashion.

DO NOT USE UNDER THE INFLUENCE OF DRUGS OR ALCOHOL, OR WHEN TIRED.



Mounting

The Model G0711 can be mounted on the optional Model G0712 stand or a sturdy workbench.

Optional Stand (G0712)

Instructions for mounting the planishing hammer to this stand are provided with the stand. Follow those instructions, then continue with the **Assembly & Setup** instructions provided on this sheet.

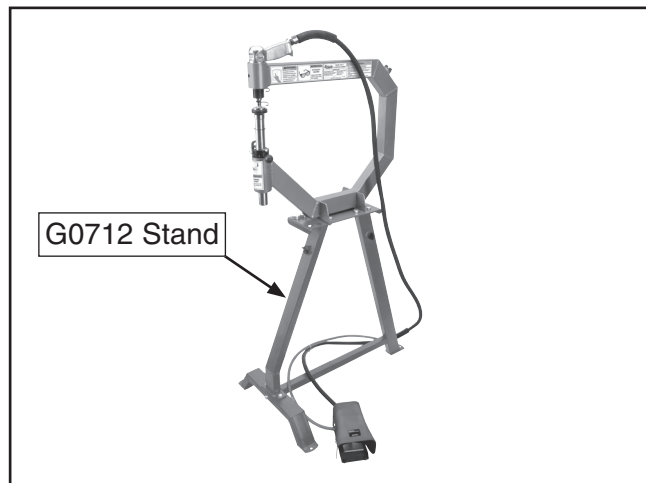

Figure 2. Mounted on G0712 optional stand.

Workbench

Make sure the workbench is sturdy enough to support the weight of both the machine and workpieces, and the forces that will occur while hammering. Also, make sure the workbench is not so tall that the foot switch cannot be comfortably placed on the floor.

Place the C-frame on the workbench so the hammer/anvil portion extends over the edge, as shown below.

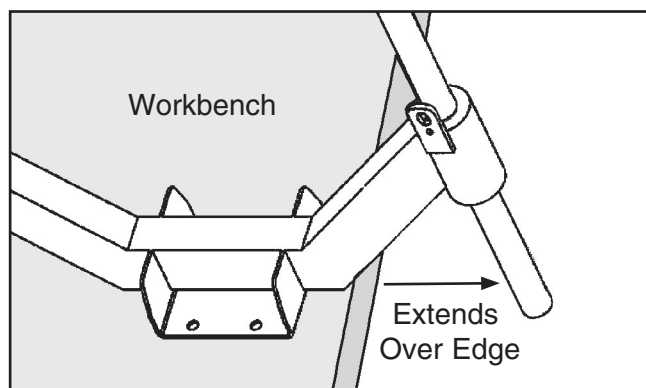

Figure 3. Frame mounted so hammer/anvil portion extends over edge of workbench.

Use $\frac{3}{8}$ " (or 10mm) diameter fasteners. The length of the bolts/screws will depend on the thickness of the workbench. The type of fasteners required to install the planishing hammer will depend on how you choose to mount it. The two most common options for mounting are the through-mount and direct-mount methods (see **Figures 4–5** below).

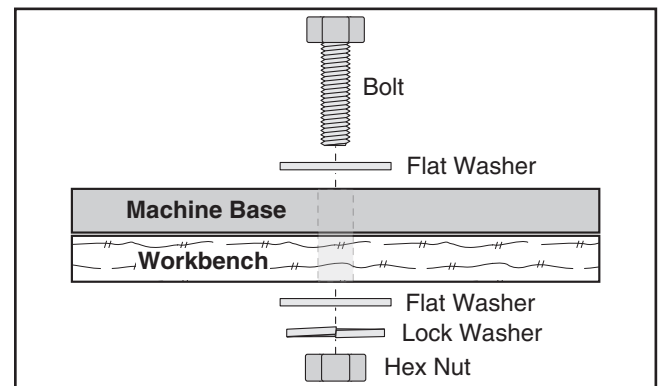

Figure 4. Through-mount method.

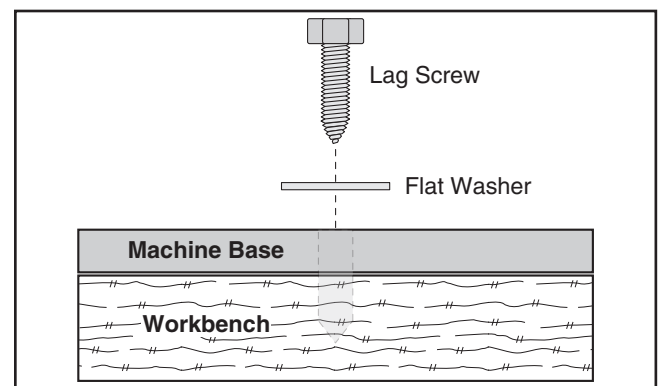

Figure 5. Direct-mount method.

After the C-frame has been positioned where you want to mount it, transfer the mounting hole locations from the C-frame mounting plate into the workbench, so they are marked clearly for drilling.

One way to transfer these hole locations accurately is to place a $\frac{3}{8}$ " (or 10mm) drill bit in the mounting hole with the bit pointing against the workbench. Lightly tap the backside of the drill bit with a hammer, rotate the drill bit 90°, then tap it again. This method will leave a light "X" in the surface of the workbench, which is centered in the hole.

Drill or pre-drill the mounting holes as necessary for the fasteners you will use for mounting. (A $\frac{1}{4}$ " drill bit is commonly used to pre-drill for $\frac{3}{8}$ ".)

Assembly & Setup

The Model G0711 requires a source of compressed air that can consistently deliver 4 CFM at 50-100 PSI.

Since the Model G0711 must be lubricated before each use, and at regular operating intervals, we recommend using a filter/lubricator/regulator with your compressed air line (see **Figure 6**) below.

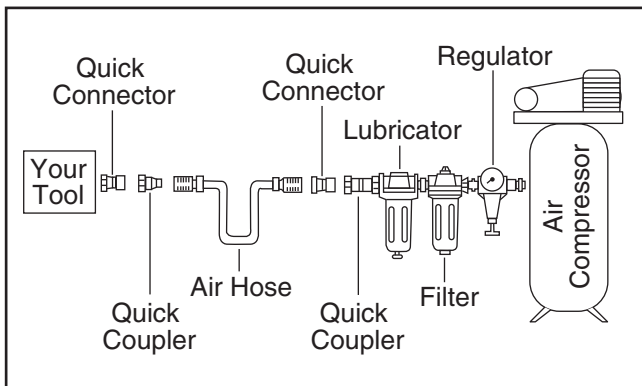

Figure 6. Air line setup with filter/lubricator/regulator installed.

The Model G0711 can also be filled with fine sand to reduce vibration and noise during operation; however, this is optional.

Items Needed for Assembly	Qty
• Hex Wrench 4mm	1
• Hex Wrench 5mm	1
• Fine Sand 40 Lb. Bag (Optional)	1

To assemble and set up the Model G0711:

1. Insert the hammer assembly into the top of the C-frame assembly, position it as shown in **Figure 7**, and tighten the set screw.



Figure 7. Hammer installed in C-frame.

2. Pull the hammer assembly spring loop to the side and insert the hammer into the coil spring, making sure the ring on the hammer shaft is over the bottom spring loop, as shown in **Figure 7**.

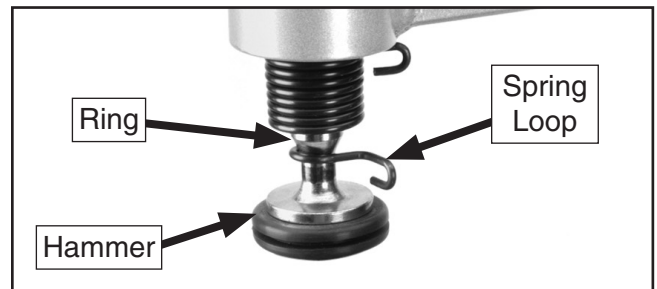

Figure 8. Hammer installed in spring.

3. Insert a die into the die housing, as shown in **Figure 9**.



Figure 9. Die inserted.

4. Raise the die housing up, and insert the pin as shown in **Figure 10** to position the die near the hammer.

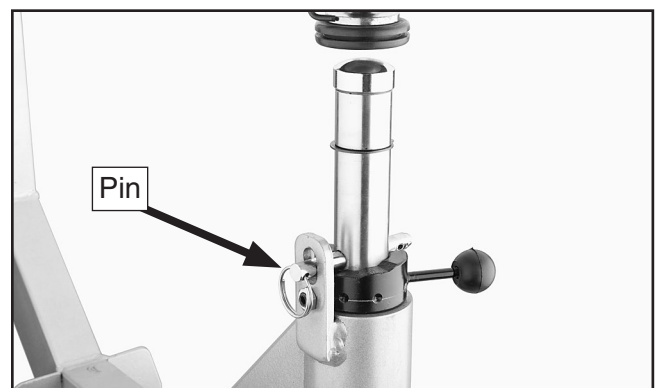

Figure 10. Pin inserted through bracket and housing to position the die upward.

5. Raise the die up close to the hammer by moving the die housing lever to the left.



Figure 11. Raising the die up closer to the hammer using the die housing lever.

6. **(Optional)** Remove the plug (part #28) from the C-frame, and use a funnel or other tool to pour sand into the frame. Replace plug when complete.
7. Place 8-10 drops of pneumatic tool oil into the air fitting on the foot switch and another 8-10 drops in the air fitting installed in the hammer assembly. This is more than the usual amount of lubrication you will use during maintenance. The purpose of this is to "load up" the pneumatic components when they are new.
8. Connect the air supply to the hose coming out of the foot switch (see **Figure ??**).

Note: *There are many different styles of quick connect fittings. If the air fitting supplied with the Model G0711 does not fit the style you have on your hose, you will need to make them match.*

9. Place the foot switch on the floor, then position it in a comfortable operating position.
10. Adjust the air pressure to 50 PSI.
11. If you have not already done so, put on your safety glasses and hearing protection now.

12. Test the operation of the planishing hammer by briefly pushing and releasing the foot switch. The hammer should actuate.

—If the hammer **DOES** actuate, the machine is operating correctly and you are finished with the **Assembly & Setup**.

—If the hammer **DOES NOT** actuate, adjust the air pressure up 20 PSI, then test the foot switch again. If the hammer still **DOES NOT** actuate after this test, adjust the speed adjustment knob on the planishing hammer assembly (**Figure 12**) and try again.

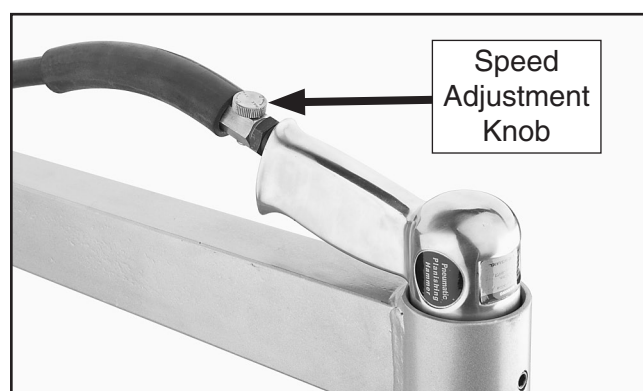

Figure 12. Speed adjustment knob.

—If the planishing hammer still does not actuate, and you have verified that the air pressure valve is turned **ON**, Contact Grizzly Tech Support for help.

Installing an In-Line Lubricator (Optional)

To make maintenance easier and increase the life of your hammer, we recommend installing an in-line lubricator between the speed adjustment knob and the air hose that feeds the hammer assembly.

This will ensure that your hammer assembly receives a continuous supply of lubrication during operation.



Operation

The basic operation of a planishing hammer consists of inserting a piece of sheet metal between the hammer and die, then actuating the planishing hammer while moving the sheet metal around to shape it.

There are three main variables that can be adjusted to alter the results of your work:

- **Die Radius:** Controls the curve of the shaped workpiece. Change this by installing dies with different radii.
- **Air Supply PSI:** Controls the force of each blow of the hammer. Change this by adjusting the air pressure between 50-100 PSI.
- **Hammer Speed:** Controls how fast and hard the hammer strikes the die while the foot switch is pressed. This is measured in BPM's (beats per minute). Change this by adjusting the speed adjustment knob on the hammer assembly.

To perform a basic operation with the planishing hammer:

1. DISCONNECT THE AIR PRESSURE!
2. Insert the desired die size into the housing.
3. Adjust the height of the die, using the die elevation lever (**Figure 13**) to accommodate the thickness or gauge of your workpiece

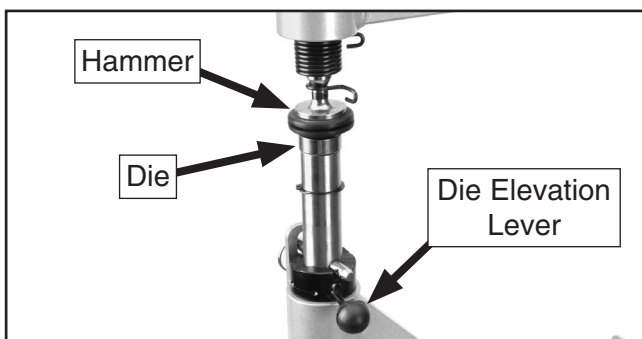

Figure 13. Die elevation lever.

4. Connect the air pressure and adjust the air supply PSI between 50-100, using your air regulator.
5. Adjust the hammer speed, using the speed adjustment knob on the hammer assembly.
6. Insert the workpiece between the hammer and die, press down on the foot switch, and move the workpiece around to shape it.
7. When a shaping task is complete, remove your foot from the pedal to stop the planishing hammer.
8. At the end of the day, or before leaving the planishing hammer unattended, disconnect the air supply from the foot switch and press the foot switch to release any remaining air pressure.

Maintenance

Before Every Use

- If lubricating manually, place 5 drops of pneumatic tool oil in the foot switch air fitting and the hammer assembly air fitting.
- If you are using an in-line lubricator, check the oil level; refill as needed with pneumatic tool oil.
- Check all mounting and component hardware and fasteners; adjust/tighten as necessary.
- Check all air connections; replace leaking or defective connections.

Available Accessories from Grizzly

G0712—Metal Stand for G0711

Assembles in minutes and mounts directly to the planishing hammer. Like the C-frame on the planishing hammer, the stand can be filled with sand to reduce vibration and noise.

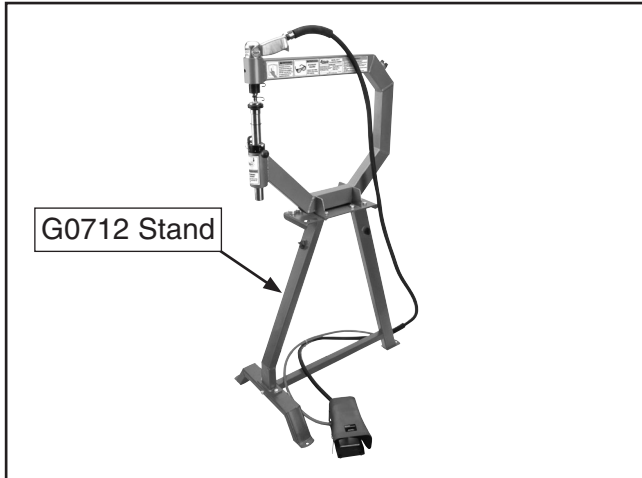

Figure 14. Mounted on G0712 optional stand.

G2820—Pneumatic Tool Oil 8 oz Bottle

G7615—Oil Can w/Steel Nozzle

G7616—Oil Can w/Plastic Nozzle

G7617—Oil Can w/Flexible Plastic Nozzle

Use the right oil! This pneumatic tool oil offers outstanding heat displacement and friction reduction without eating away at delicate air components like detergent motor oils. Stock up with extra bottles to avoid costly downtime. If you're lubricating your tools, you'll appreciate these High Pressure Oil Cans. Each can holds 5 ounces of oil and has a trigger activated, high pressure pump.



Figure 116. Pneumatic tool oil and oil cans.

Call 1-800-523-4777 To Order

H3171—4-Pc. Air Fitting Set 1/4" NPT

H3175—Female QC (Quick Coupler) 1/4" NPT

H3177—Male QC 1/4" NPT w/Male Threads

H3178—Male QC 1/4" NPT w/Female Threads

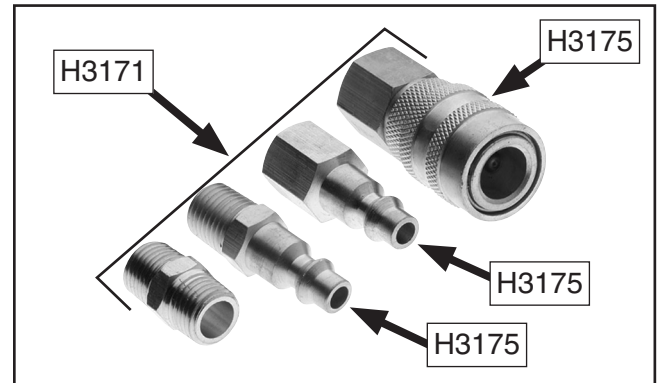

Figure 17. 1/4" NPT Air Fittings.

T20881—In-Line Lubricator 1/4" NPT

T20882—Mini Regulator 1/4" NPT

G6261—Water Filter 1/4" NPT

Install an in-line lubricator to apply oil automatically. Install an air regulator right at the tool for precise air control. Install this filter in your air supply line to prevent water from traveling into your expensive air tools, and ruining them.



Figure 18. In-line pneumatic components.

G8114—Rubber Air Hose 3/8" x 25 Ft. 1/4" NPT

G8115—Rubber Air Hose 3/8" x 50 Ft. 1/4" NPT



Figure 19. Red rubber air hose (rated 200 PSI).



G0711 Parts Breakdown

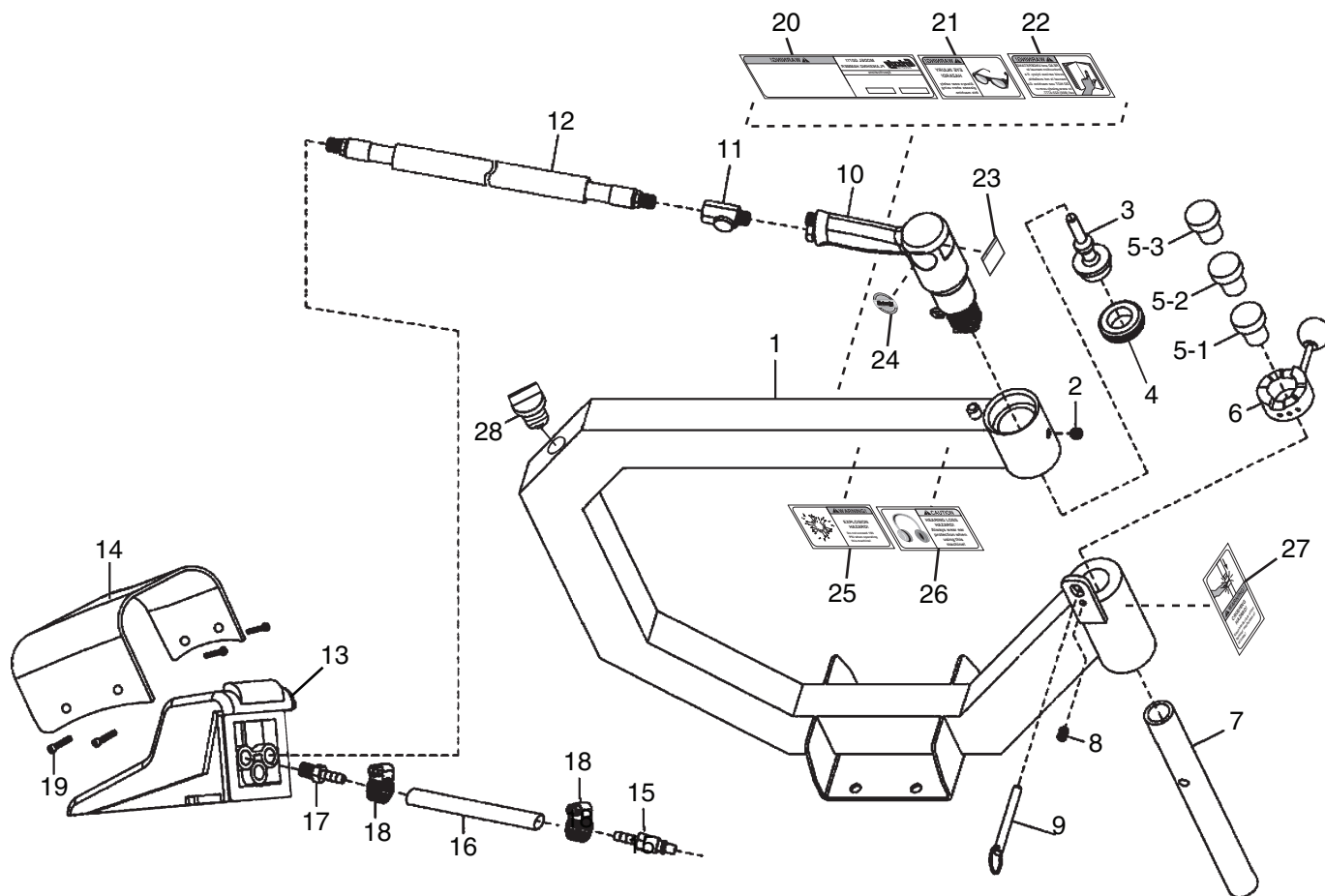

REF	PART #	DESCRIPTION
1	P0711001	C-FRAME
2	PSS30M	SET SCREW M10-1.5 X 10
3	P0711003	HAMMER SHAFT
4	P0711004	HAMMER HEAD
5-1	P0711005-1	DIE 7/8" SHAFT 1" RADIUS
5-2	P0711005-2	DIE 7/8" SHAFT 2" RADIUS
5-3	P0711005-3	DIE 7/8" SHAFT 3" RADIUS
6	P0711006	DIE ELEVATION BLOCK
7	P0711007	DIE HOUSING
8	P0711008	BALL-END SET SCREW M8-1.25 X 20
9	P0711009	STOPPER PIN
10	P0711010	AIR HAMMER ASSEMBLY
11	P0711011	REGULATOR
12	P0711012	AIR HOSE 3/8" 250 PSI
13	P0711013	FOOT SWITCH ASSEMBLY

REF	PART #	DESCRIPTION
14	P0711014	COVER
15	P0711015	QUICK CONNECT MALE 1/4"-PO
16	P0711016	PU AIR HOSE 1/4"
17	P0711017	MALE 1/4"-PUSH ON FITTING
18	P0711018	HOSE CLAMP 1/2"
19	PS05M	PHLP HD SCR M5-.8 X 8
20	P0711020	MACHINE ID LABEL
21	PLABEL-11C	SAFETY GLASSES LABEL
22	PLABEL-12B	READ MANUAL LABEL
23	P0711023	HAMMER LABEL
24	P0711024	GRIZZLY ROUND LOGO
25	P0711025	EXPLOSION LABEL
26	PLABEL-15C	HEARING SAFETY LABEL
27	P0711027	CRUSHING LABEL
28	P0711028	PLASTIC FILL PLUG

⚠️ WARNING

Safety labels warn about machine hazards and ways to prevent injury. The owner of this machine **MUST** maintain the original location and readability of the labels on the machine. If any label is removed or becomes unreadable, **REPLACE** that label before using the machine again. Contact Grizzly at (800) 523-4777 or www.grizzly.com to order new labels.



Free Manuals Download Website

<http://myh66.com>

<http://usermanuals.us>

<http://www.somanuals.com>

<http://www.4manuals.cc>

<http://www.manual-lib.com>

<http://www.404manual.com>

<http://www.luxmanual.com>

<http://aubethermostatmanual.com>

Golf course search by state

<http://golfingnear.com>

Email search by domain

<http://emailbydomain.com>

Auto manuals search

<http://auto.somanuals.com>

TV manuals search

<http://tv.somanuals.com>