

Grizzly *Industrial, Inc.*®

MODEL G0677 24" PLANER/SANDER OWNER'S MANUAL



COPYRIGHT © NOVEMBER, 2008 BY GRIZZLY INDUSTRIAL, INC.
**WARNING: NO PORTION OF THIS MANUAL MAY BE REPRODUCED IN ANY SHAPE
OR FORM WITHOUT THE WRITTEN APPROVAL OF GRIZZLY INDUSTRIAL, INC.**
#BLTS11320 PRINTED IN USA

WARNING!

This manual provides critical safety instructions on the proper setup, operation, maintenance and service of this machine/equipment.

Failure to read, understand and follow the instructions given in this manual may result in serious personal injury, including amputation, electrocution or death.

The owner of this machine/equipment is solely responsible for its safe use. This responsibility includes but is not limited to proper installation in a safe environment, personnel training and usage authorization, proper inspection and maintenance, manual availability and comprehension, application of safety devices, blade/cutter integrity, and the usage of personal protective equipment.

The manufacturer will not be held liable for injury or property damage from negligence, improper training, machine modifications or misuse.

WARNING!

Some dust created by power sanding, sawing, grinding, drilling, and other construction activities contains chemicals known to the State of California to cause cancer, birth defects or other reproductive harm. Some examples of these chemicals are:

- **Lead from lead-based paints.**
- **Crystalline silica from bricks, cement and other masonry products.**
- **Arsenic and chromium from chemically-treated lumber.**

Your risk from these exposures varies, depending on how often you do this type of work. To reduce your exposure to these chemicals: Work in a well ventilated area, and work with approved safety equipment, such as those dust masks that are specially designed to filter out microscopic particles.

Table of Contents

INTRODUCTION	2	SECTION 7: SERVICE	39
Manual Accuracy	2	Troubleshooting	39
Contact Info.....	2	Table Calibration.....	42
Functional Overview	2	Table Limit Switches.....	42
Controls & Features.....	3	Brake Service.....	43
Machine Data Sheet	5	Belt Tracking Adjustments	44
SECTION 1: SAFETY	8	Table Parallelism	46
Safety Instructions for Machinery	8	Pressure Rollers	49
Additional Safety for Planer/Sanders	10	Adjusting Depth of Cut Safety Bar.....	50
SECTION 2: CIRCUIT REQUIREMENTS	11	V-Belt Tension	50
220/440V Operation.....	11	Changing V-Belts.....	52
440V Conversion	12	Feed Belt Replacement	55
SECTION 3: SETUP	13	Feed Belt Tension.....	57
Setup Safety	13	Feed Belt Tracking.....	57
Items Needed for Setup.....	13	Sanding Belt Limit Switches	58
Unpacking	13	Sanding Belt Tension Limit Switch	58
Inventory	14	Chip Breaker and Tension.....	59
Clean Up.....	15	Anti-Kickback Fingers	59
Site Considerations.....	16	Air System Diagram.....	60
Moving & Placing Planer/Sander	17	SECTION 8: WIRING	61
Mounting to Shop Floor	17	Electrical Safety Instructions.....	61
Air Hose	18	Electrical Overview	62
Dust Collection.....	18	Electrical Cabinet.....	63
Sanding Belt.....	19	Control Panel	66
Pressure Roller Height.....	20	Electrical Components A	67
Gear Box Oil	21	Electrical Components B	68
Breather Pin.....	21	Electrical Components C	69
Test Run	22	Electrical Components D	70
Recommended Adjustments.....	23	SECTION 9: PARTS	71
SECTION 4: OPERATIONS	24	Tool Box & Accessories Breakdown.....	71
Basic Controls.....	24	Sanding Motor System Breakdown	72
Adjusting Feed Rate	26	Table Lift System Breakdown.....	74
Oscillation Speed	27	Conveyor System Breakdown	76
Choosing Sandpaper	27	Feed, Drum, & Pressure Roller Breakdown	78
Sanding Belt Replacement	27	Sanding Drum Breakdown.....	80
Amp Load Meter	28	Helical Cutterhead Breakdown	81
Emergency Stop Plate	28	Upper Roller System Breakdown.....	83
Planing/Sanding.....	29	Cabinet Assembly Breakdown.....	85
Rotating Carbide Inserts	31	Main Wiring Panel & Controls Breakdown... ..	86
Sanding Tips.....	32	Belt Oscillation System Breakdown.....	87
Workpiece Inspection.....	33	Labels and Cosmetic Parts Breakdown.....	88
SECTION 5: ACCESSORIES	34	WARRANTY AND RETURNS	93
SECTION 6: MAINTENANCE	35		
Schedule	35		
Lubrication	35		
Cleaning Sanding Belts	37		
Cleaning Feed Belt	37		
Dust and Water Traps.....	38		
Air System.....	38		

INTRODUCTION

Manual Accuracy

We are proud to offer this manual with your new machine! We've made every effort to be exact with the instructions, specifications, drawings, and photographs of the machine we used when writing this manual. However, sometimes errors do happen and we apologize for them.

Also, owing to our policy of continuous improvement, **your machine may not exactly match the manual**. If you find this to be the case, and the difference between the manual and machine leaves you in doubt, immediately call our technical support for updates or clarification.

For your convenience, we always keep current Grizzly manuals and most updates available on our website at **www.grizzly.com**. Any updates to your machine will be reflected in these documents as soon as they are complete. Visit our site often to check for the latest updates!

Contact Info

We stand behind our machines. If you have any service questions, parts requests or general questions about the machine, please call or write us at the location listed below.

Grizzly Industrial, Inc.
1203 Lycoming Mall Circle
Muncy, PA 17756
Phone: (570) 546-9663
Fax: (800) 438-5901
E-Mail: techsupport@grizzly.com

If you have any comments regarding this manual, please write to us at the address below:

Grizzly Industrial, Inc.
c/o Technical Documentation Manager
P.O. Box 2069
Bellingham, WA 98227-2069
Email: manuals@grizzly.com

Functional Overview

This machine is designed to remove the top surface of a workpiece then sand it smooth so it is ready for finish spraying or other uses.

In a typical operation, the operator sets the depth of cut, turns the sanding drum and feed motors **ON**, sets the speed of the feed belt, then feeds the workpiece into the machine.

The feed belt moves the workpiece under the cutterhead and sanding drum, then out the other side. The workpiece can be fed through additional times until the desired thickness and finish are achieved.

The oscillation system shifts the sanding belt from side-to-side on the sanding drum to produce an even sanding finish across the width of the workpiece. The sanding motor brake unit brings the cutterhead and sanding belt to a quick stop when the power is turned **OFF**.



Controls & Features

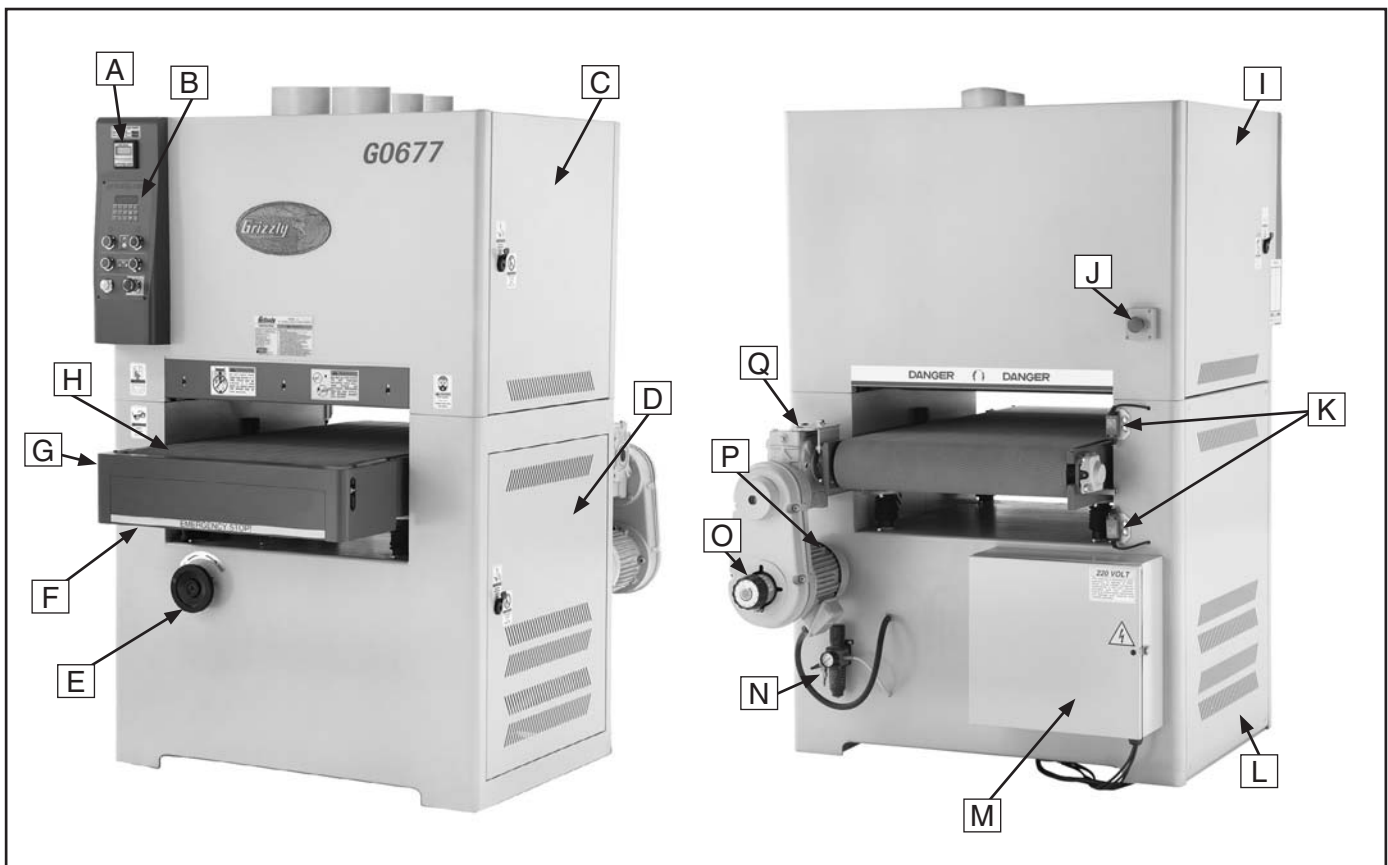

Figure 1. Front and rear views.

- | | |
|---|--|
| A. Amp Load Meter | J. Rear Stop Button |
| B. Control Panel (refer to Page 24 for details) | K. Upper and Lower Table Limit Switches |
| C. Upper Right Access Door | L. Lower Left Access Panel |
| D. Lower Right Access Panel | M. Main Wiring Box |
| E. Table Height Handwheel | N. Air Pressure Regulator |
| F. Emergency Stop Plate | O. Variable Feed Rate Dial |
| G. Conveyor Table | P. Feed Motor |
| H. Feed Belt | Q. Feed Belt Gear Box |
| I. Upper Left Access Door | |

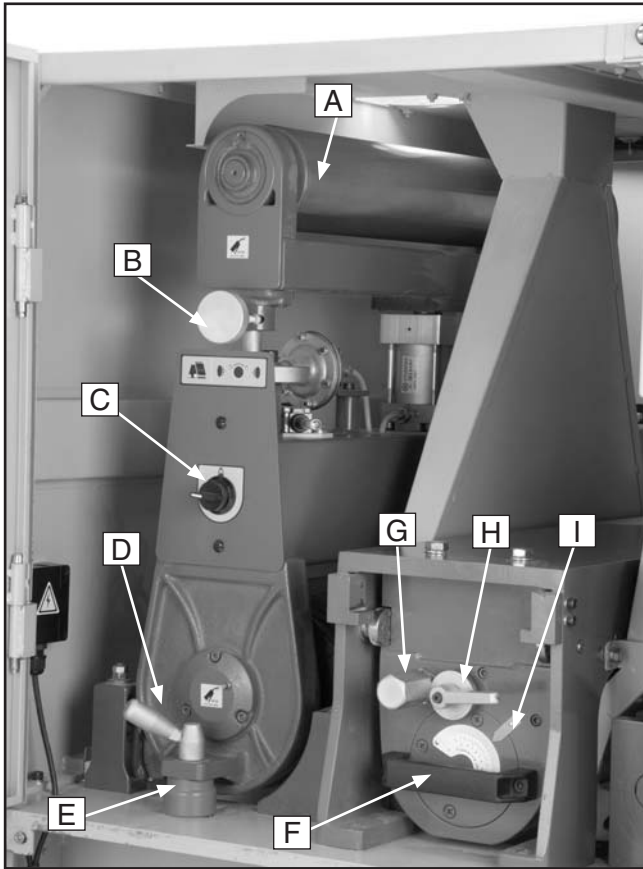

Figure 2. Inside left access door.

- A.** Upper Roller
- B.** Oscillation Adjustment Knob
- C.** Belt Tension Knob
- D.** Lock Post Release Lever
- E.** Stop Block
- F.** Cutterhead Access Handle
- G.** Cutterhead Adjustment Shaft
- H.** Cutterhead Lock Handle
- I.** Cutterhead Height Scale

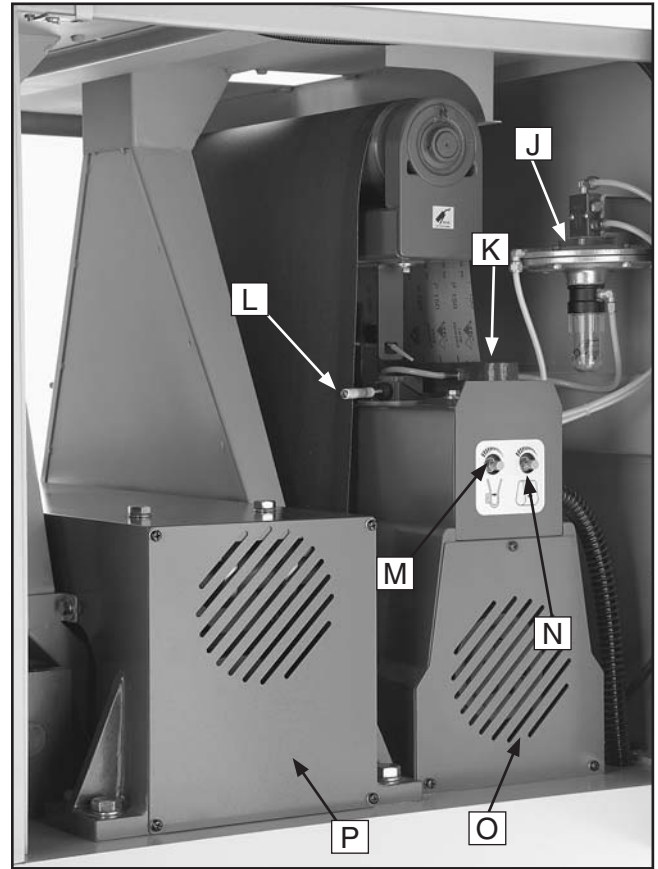

Figure 3. Inside right access door.

- J.** Diaphragm Valve Assembly
- K.** Air Fork and Air Jet
- L.** Belt Tracking Limit Switch
- M.** Airflow Adjustment Knob
- N.** Oscillation Speed Control Adjustment Knob
- O.** Sanding Belt Safety Cover
- P.** Cutterhead Safety Cover





MACHINE DATA SHEET

Customer Service #: (570) 546-9663 · To Order Call: (800) 523-4777 · Fax #: (800) 438-5901

MODEL G0677 24" 15 HP 3-PHASE DOUBLE-HEAD WIDE-BELT SANDER

Product Dimensions:

Weight..... 2314 lbs.
 Length/Width/Height..... 44-1/2 x 61 x 68 in.
 Foot Print (Length/Width)..... 42-1/2 x 31 in.

Shipping Dimensions:

Type..... Wood Slat
 Content..... Machine
 Weight..... 2645 lbs.
 Length/Width/Height..... 63 x 47 x 76 in.

Electrical:

Switch..... ON/OFF Emergency Stop
 Minimum Circuit Size..... .50A@220V, 30A@440V
 Recommended Plug/Outlet Type..... Hardwire to Locking Disconnect Switch

Motors:

Table Elevation Feed

Type..... TEFC Induction
 Horsepower..... 1/4 HP
 Voltage..... 220V/440V
 Prewired..... 220V
 Phase..... Three
 Amps..... 1.2/0.6A
 Speed..... 1725 RPM
 Cycle..... 60 Hz
 Number Of Speeds..... 1
 Power Transfer V-Belt Drive
 Bearings..... Sealed and Lubricated

Sanding Drum/Cutterhead

Type..... TEFC Induction
 Horsepower..... 15 HP
 Voltage..... 220V/440V
 Prewired..... 220V
 Phase..... Three
 Amps..... 36/18A
 Speed..... 3450 RPM
 Cycle..... 60 Hz
 Number Of Speeds..... 1
 Power Transfer V-Belt Drive
 Bearings..... Sealed and Lubricated



Conveyor Feed

Type..... TEFC Induction
Horsepower..... 1 HP
Voltage..... 220V/440V
Prewired..... 220V
Phase..... Three
Amps..... 3.4/1.7A
Speed..... 1725 RPM
Cycle..... 60 Hz
Number Of Speeds..... Adjustable, 14-60 FP
Power Transfer V-Belt Drive
Bearings..... Sealed and Lubricated

Main Specifications:

Operation Information

No Of Sanding Drums..... 1
Maximum Board Width..... 24 in.
Minimum Board Width..... 2 in.
Maximum Board Thickness..... 6 in.
Minimum Board Thickness..... 1/4 in.
Minimum Board Length..... 12 in.
Conveyor Feed Rate..... 14 - 60 FPM
Sanding Belt Length..... 60 in.
Sanding Belt Width..... 25 in.

Drum Information

Infeed Sanding Drum Type..... Spiral Grooved Rubber
Infeed Sanding Drum Size..... 7-7/8 in.

Construction

Conveyor Belt Construction..... Rubber
Body Construction..... Steel
Base Construction..... Steel
Paint..... Epoxy

Other Related Information

Floor To Belt Height..... 32 in.
Belt Tracking..... Pneumatic
Sanding Belt Tension..... Pneumatic
No Of Pressure Rollers..... 3
Pressure Roller Type..... Rubber
Pressure Roller Size..... 1-9/16 in.
Conveyor Belt Length..... 102-3/8 in.
Conveyor Belt Width..... 24 in.
No Of Dust Ports..... 4
Dust Port Size..... 5 in.
Air Requirement..... 75 PSI

Other Specifications:

Country Of Origin Taiwan
Serial Number Location ID Label on Center of the Stand
Assembly Time 20 Minutes



Features:

- Spiral Cutterhead Height Adjustable, Allowing Greater Control Over Workpiece Finish
- Spiral Cutterhead Assembly Quickly Unbolts and Slides Out for Easy Access
- Foot Pedal Lever Quickly Releases Sanding Motor V-Belt Tension
- Variable Feed Speeds
- Disc Brake Emergency Stop
- Pneumatic Belt Tracking
- Digital Amp/Load Meter
- Digital Keypad Controlled Table Elevation



SECTION 1: SAFETY

WARNING

For Your Own Safety, Read Instruction Manual Before Operating this Machine

The purpose of safety symbols is to attract your attention to possible hazardous conditions. This manual uses a series of symbols and signal words intended to convey the level of importance of the safety messages. The progression of symbols is described below. Remember that safety messages by themselves do not eliminate danger and are not a substitute for proper accident prevention measures.



Indicates an imminently hazardous situation which, if not avoided, **WILL** result in death or serious injury.



Indicates a potentially hazardous situation which, if not avoided, **COULD** result in death or serious injury.



Indicates a potentially hazardous situation which, if not avoided, **MAY** result in minor or moderate injury. It may also be used to alert against unsafe practices.

NOTICE

This symbol is used to alert the user to useful information about proper operation of the machine.

WARNING

Safety Instructions for Machinery

- 1. READ THE ENTIRE MANUAL BEFORE STARTING MACHINERY.** Machinery presents serious injury hazards to untrained users.
- 2. ALWAYS USE ANSI APPROVED SAFETY GLASSES WHEN OPERATING MACHINERY.** Everyday eyeglasses only have impact resistant lenses—they are NOT safety glasses.
- 3. ALWAYS WEAR A NIOSH APPROVED RESPIRATOR WHEN OPERATING MACHINERY THAT PRODUCES DUST.** Most types of dust (wood, metal, etc.) can cause severe respiratory illnesses.
- 4. ALWAYS USE HEARING PROTECTION WHEN OPERATING MACHINERY.** Machinery noise can cause permanent hearing loss.
- 5. WEAR PROPER APPAREL. DO NOT** wear loose clothing, gloves, neckties, rings, or jewelry that can catch in moving parts. Wear protective hair covering to contain long hair and wear non-slip footwear.
- 6. NEVER OPERATE MACHINERY WHEN TIRED OR UNDER THE INFLUENCE OF DRUGS OR ALCOHOL.** Be mentally alert at all times when running machinery.



WARNING

Safety Instructions for Machinery

7. **ONLY ALLOW TRAINED AND PROPERLY SUPERVISED PERSONNEL TO OPERATE MACHINERY.** Make sure operation instructions are safe and clearly understood.
8. **KEEP CHILDREN AND VISITORS AWAY.** Keep all children and visitors a safe distance from the work area.
9. **MAKE WORKSHOP CHILDPROOF.** Use padlocks, master switches, and remove start switch keys.
10. **NEVER LEAVE WHEN MACHINE IS RUNNING.** Turn power **OFF** and allow all moving parts to come to a complete stop before leaving machine unattended.
11. **DO NOT USE IN DANGEROUS ENVIRONMENTS.** DO NOT use machinery in damp, wet locations, or where any flammable or noxious fumes may exist.
12. **KEEP WORK AREA CLEAN AND WELL LIGHTED.** Clutter and dark shadows may cause accidents.
13. **USE A GROUNDED EXTENSION CORD RATED FOR THE MACHINE AMPERAGE.** Grounded cords minimize shock hazards. Undersized cords create excessive heat. Always replace damaged extension cords.
14. **ALWAYS DISCONNECT FROM POWER SOURCE BEFORE SERVICING MACHINERY.** Make sure switch is in OFF position before reconnecting.
15. **MAINTAIN MACHINERY WITH CARE.** Keep blades sharp and clean for best and safest performance. Follow instructions for lubricating and changing accessories.
16. **MAKE SURE GUARDS ARE IN PLACE AND WORK CORRECTLY BEFORE USING MACHINERY.**
17. **REMOVE ADJUSTING KEYS AND WRENCHES.** Make a habit of checking for keys and adjusting wrenches before turning machinery **ON**.
18. **CHECK FOR DAMAGED PARTS BEFORE USING MACHINERY.** Check for binding or misaligned parts, broken parts, loose bolts, and any other conditions that may impair machine operation. Repair or replace damaged parts before operation.
19. **USE RECOMMENDED ACCESSORIES.** Refer to the instruction manual for recommended accessories. Improper accessories increase risk of injury.
20. **DO NOT FORCE MACHINERY.** Work at the speed for which the machine or accessory was designed.
21. **SECURE WORKPIECE.** Use clamps or a vise to hold the workpiece when practical. A secured workpiece protects your hands and frees both hands to operate the machine.
22. **DO NOT OVERREACH.** Maintain stability and balance at all times.
23. **MANY MACHINES CAN EJECT WORKPIECES TOWARD OPERATOR.** Know and avoid conditions that cause the workpiece to "kickback."
24. **ALWAYS LOCK MOBILE BASES (IF USED) BEFORE OPERATING MACHINERY.**
25. **CERTAIN DUST MAY BE HAZARDOUS** to the respiratory systems of people and animals, especially fine dust. Be aware of the type of dust you are exposed to and always wear a respirator designed to filter that type of dust.



WARNING

Additional Safety for Planer/Sanders

- 1. INSTRUCTION MANUAL.** This machine presents significant safety hazards to untrained users. Read/understand this entire manual before starting the planer/sander. Never allow unsupervised or untrained personnel to operate the machine.
- 2. REACHING INSIDE MACHINE.** Never reach inside planer/sander or remove covers when the planer/sander is connected to power. Never place hands near, or in contact with, sanding drum, or feed belt during operation.
- 3. INFEEED/OUTFEED AREA.** When feeding workpiece into the machine, keep clear of kickback path by standing to the side of the feed belt. Kickback is when the workpiece is thrown off the machine sander by the force of the cutterhead or sanding drum. Make sure the workpiece has enough room to exit the machine before starting.
- 4. LOOKING INSIDE PLANER.** Wood chips fly around inside the planer/sander at a high rate of speed. DO NOT look inside the machine or remove guards/covers during operation.
- 5. CORRECT MATERIAL.** Only plane/sand natural wood stock with this planer. DO NOT plane/sand MDF, plywood, laminates, synthetic products or metals.
- 6. GRAIN DIRECTION.** Planing/sanding across the grain is hard on the machine and may cause the workpiece to kick out. Always plane/sand in the same direction or at a slight angle with the wood grain.
- 7. WORKPIECE LIMITS.** Never sand or plane workpieces narrower than 2", thinner than 1/4" and shorter than 12".
- 8. CLEAN STOCK.** Planing/sanding stock with nails, staples, or loose knots MAY cause debris to kick out at the operator and WILL damage your inserts/sanding belt when they make contact. Always thoroughly inspect and prepare stock to avoid these hazards.
- 9. REMOVING JAMMED WORKPIECES.** To avoid serious injury, always stop the planer/sander and disconnect power before removing jammed workpieces.
- 10. DULL/DAMAGED INSERTS.** The planer may kick out a workpiece at the operator or give poor finish results if it is operated with dull or damaged inserts.
- 11. POWER AND AIR DISCONNECT.** Unless specifically stated in the manual, always disconnect the power source and air supply from the machine when performing maintenance, adjustments, or assembly.
- 12. WORKPIECE FEEDING.** Never force the workpiece into machine, and feed only one workpiece at a time.
- 13. CLOTHING.** Roll up or button sleeves, tie all loose clothing or hair so it will keep clear of entanglement hazards.
- 14. DUST COLLECTION.** Never operate the machine without an adequate dust collection system in place and running.
- 15. ALLERGIES.** Certain woods may cause an allergic reaction in people and animals, especially when exposed to fine dust. Make sure you know what type of wood dust you will be exposed to and always wear an approved respirator.

WARNING

Like all machinery there is potential danger when operating this machine. Accidents are frequently caused by lack of familiarity or failure to pay attention. Use this mill with respect and caution to reduce the risk of operator injury. If normal safety precautions are overlooked or ignored, serious personal injury may occur.



SECTION 2: CIRCUIT REQUIREMENTS

220/440V Operation

!WARNING

Serious personal injury could occur if you connect the machine to the power source before you have completed the setup process. **DO NOT** connect the machine to the power source until instructed after setup.



!WARNING

Electrocution or fire could result if this machine is not installed to code. You **MUST** ensure compliance by checking with a qualified electrician!

NOTICE

The Model G0677 is prewired for 220V operation. If you plan to use your machine at 440V, you **MUST** have a qualified electrician perform the 440V conversion described on Page 12.

Full Load Amp Draw

G0677 220V 3-Phase.....40.6 Amp
 G0677 440V 3-Phase.....20.3 Amp

Power Supply Circuit Requirements

The power supply circuit for your machine **MUST** be grounded and rated for the amperage given below. Never replace a circuit breaker on an existing circuit with one of higher amperage without consulting a qualified electrician to ensure compliance with wiring codes. **If you are unsure about the wiring codes in your area or you plan to connect your machine to a shared circuit, consult a qualified electrician.**

Minimum Circuit Size (220V)50 Amps
 Minimum Circuit Size (440V)30 Amps

G0677 24" Planer/Sander

Minimum Cord Requirements

For 220V or 440V connection, an electrician **MUST** hardwire the machine. The electrician who hardwires the machine will determine the appropriate wire to use inside the conduit.

Power Connection Device

The power connection device depends on the type of installed or planned service. We recommend using the device shown in **Figure 4**.

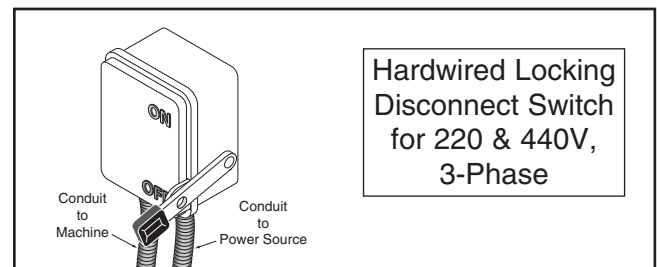

Figure 4. Recommended connection types.

Phase Converter Precaution

We do not recommend using a static phase converter with this machine. If you must use a phase converter, use a rotary-type phase converter.

When using a phase converter, the power from the manufactured power leg can fluctuate. Connect the manufactured power leg to the T terminal (see **Page 63**) to prevent damage to the transformer.

The wire from the T terminal can handle some fluctuation because it goes directly to the motor. The power going to the R and S terminals goes to the transformer and must be consistent to prevent damage to electrical components.



440V Conversion

To connect the Model G0677 to 440V three-phase power, you must purchase two thermal overload relays, Parts PH29338134 and PH29338135, or purchase the 440V Conversion Kit Part P06778134. (refer to **Page 86**). To purchase the relays or the kit, call Grizzly Customer Service at (800) 523-4777.

If you do not have three-phase power available for your planer/sander, you must install a phase converter. We recommend using a Grizzly Phase Converter such as the Model H3741 (refer to **Accessories** on **Page 34**). Refer to the **Phase Converter** sub-section on **Page 11** for requirements and setup.

All wiring changes must be performed by a qualified electrician before the planer/sander is connected to the power source. If, at any time during this procedure you need help, call Grizzly Tech Support at (570) 546-9663.

To rewire the Model G0677 for 440V operation:

1. DISCONNECT PLANER/SANDER FROM POWER!
2. Open the main wiring box located on the back of the machine (see **Figure 1, Page 3**).
3. On the transformer, remove the #1 wire connected to the 220V terminal and connect it to the 440V terminal, as shown in **Figure 5**.

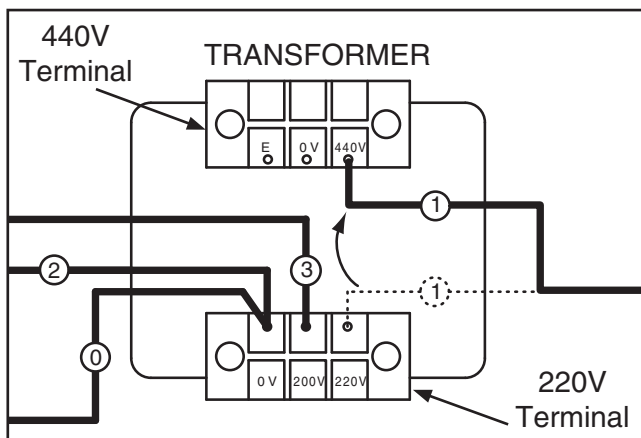

Figure 5. Rewiring transformer from 220V to 440V.

4. Swap out the sanding motor relay LR3D-3355 and conveyor motor relay LR3D-086 with the 440V thermal relays at the locations shown in **Figure 6**, and set them to 18A and 1.7A respectively.

—Use 440V Conversion Kit #P06778134 or purchase Part PH29338134 and PH29338135, and change out the two relays.

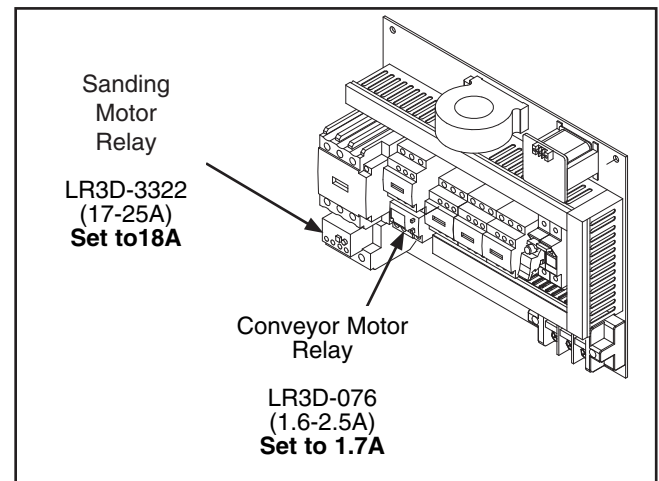

Figure 6. 440V thermal overload relays.

5. Wire the main motor, feed and table elevation motors, as shown on the diagrams on the inside of each motor wire cover, or refer to **Pages 68 & 70**.

Note: The reference wiring diagrams on **Pages 68 & 70** were current at the time of printing, but always use the wiring diagram provided inside the motor junction box, as it will reflect any changes to the motor shipped with your machine if changes were made after printing.

SECTION 3: SETUP

Setup Safety

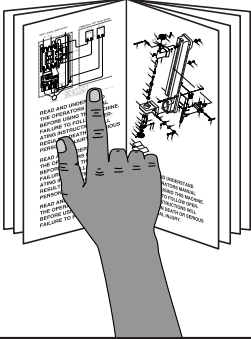

! WARNING
This machine presents serious injury hazards to untrained users. Read through this entire manual to become familiar with the controls and operations before starting the machine!



! WARNING
Wear safety glasses during the entire setup process!

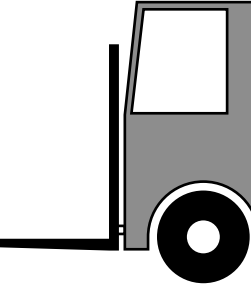

! WARNING
This machine and its components are very heavy. Use power lifting equipment such as a forklift to move heavy items.

Items Needed for Setup

The following items are needed to complete the setup process, but are not included with your machine:

Description	Qty
• Safety Glasses (for each person).....	1
• Cleaning Solvent & Rags	As Needed
• Dust Collection System	1
• 5" Dust Hoses (length as needed)	4
• 5" Hose Clamps	4
• Air Compressor (12 CFM @75 PSI)	1
• Forklift.....	1
• 20" Long 2x4	1

Unpacking

Your machine was carefully packaged for safe transportation. Remove the packaging materials from around your machine and inspect it. If you discover the machine is damaged, *please immediately call Customer Service at (570) 546-9663 for advice.*

Save the containers and all packing materials for possible inspection by the carrier or its agent. *Otherwise, filing a freight claim can be difficult.*

When you are completely satisfied with the condition of your shipment, inventory the contents.



Inventory

The following is a description of the main components shipped with your machine. Lay the components out to inventory them.

Note: If you can't find an item on this list, check the mounting location on the machine or examine the packaging materials carefully. Occasionally we pre-install certain components for shipping purposes.

Crate Contents: (Figures 7 & 8)	Qty
A. Sanding Belt 120 Grit	1
B. Sanding Belt 150 Grit	1
C. Toolbox	1
D. Door Keys.....	2
E. Ceramic Limit Switch Tips.....	2
F. Metric Hex Wrench 10-Piece Set.....	1
G. Flat Head Screwdriver.....	1
H. Phillips Head Screwdriver.....	1
I. Wrenches 8/10, 12/14, 17/19mm.....	1 Each
J. Pneumatic Screwdriver.....	1
K. Flexible Grease Gun Extension	1
L. Flat Head Torx Screws M6-1 x 15	20
M. Torx Driver T-20 10-Piece Set.....	1
N. Carbide Inserts 14 x 14 x 2	10
O. Torx Driver Breaker Bar.....	1
P. Torx Driver T-20 Bits.....	10

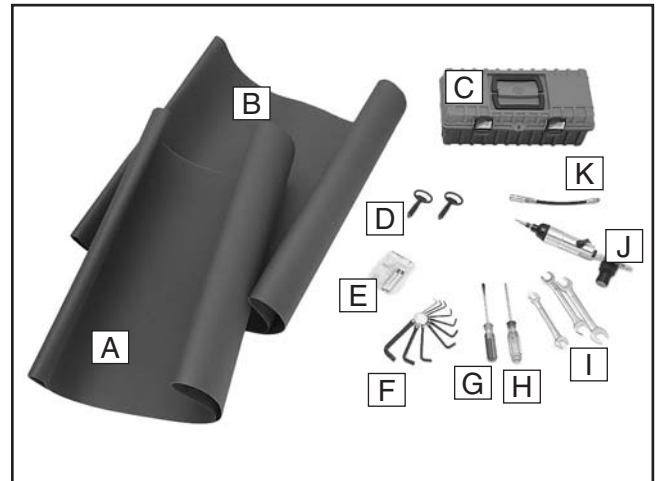

Figure 7. Crate contents 1.

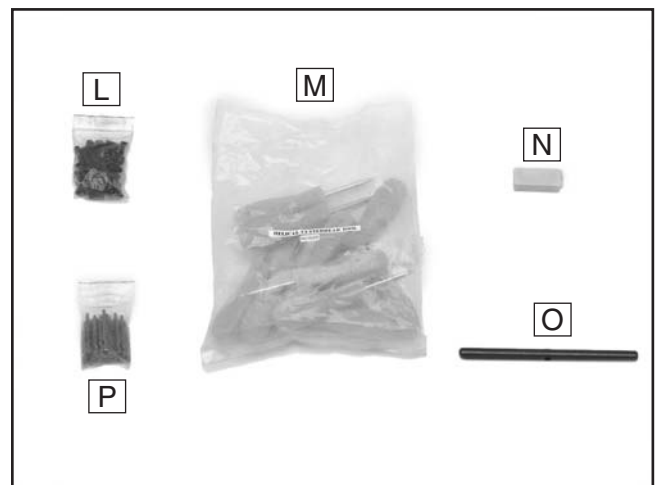

Figure 8. Crate contents 2.

If any nonproprietary parts are missing (e.g. a nut or a washer), we will gladly replace them; or for the sake of expediency, replacements can be obtained at your local hardware store.



Clean Up

Any unpainted surfaces are coated with a waxy oil to prevent corrosion during shipment. Remove this protective coating with a solvent cleaner or degreaser, such as shown in **Figure 9**. For thorough cleaning, some parts must be removed. **For optimum performance, clean all moving parts or sliding contact surfaces.** Avoid chlorine-based solvents, such as acetone or brake parts cleaner that may damage painted surfaces. Always follow the manufacturer's instructions when using any type of cleaning product.

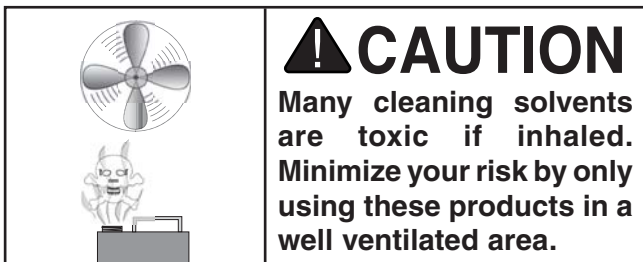
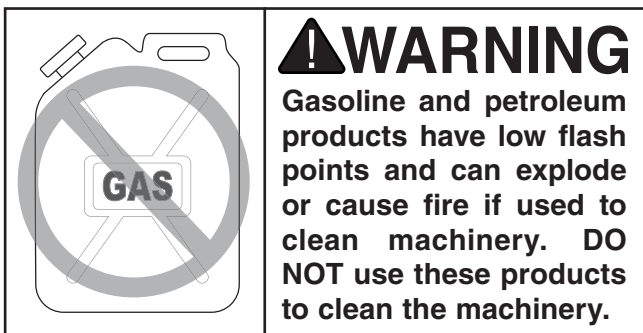

G2544—Solvent Cleaner & Degreaser
H9692—Orange Power Degreaser
Great products for removing shipping grease.



Figure 9. Cleaner/degreasers available from Grizzly.

The following surfaces need to be cleaned:

- Upper steel sanding belt roller
- Spiral cutterhead

To access the steel sanding belt roller (**Figure 10**), unlock the right or left access doors, and clean as needed.

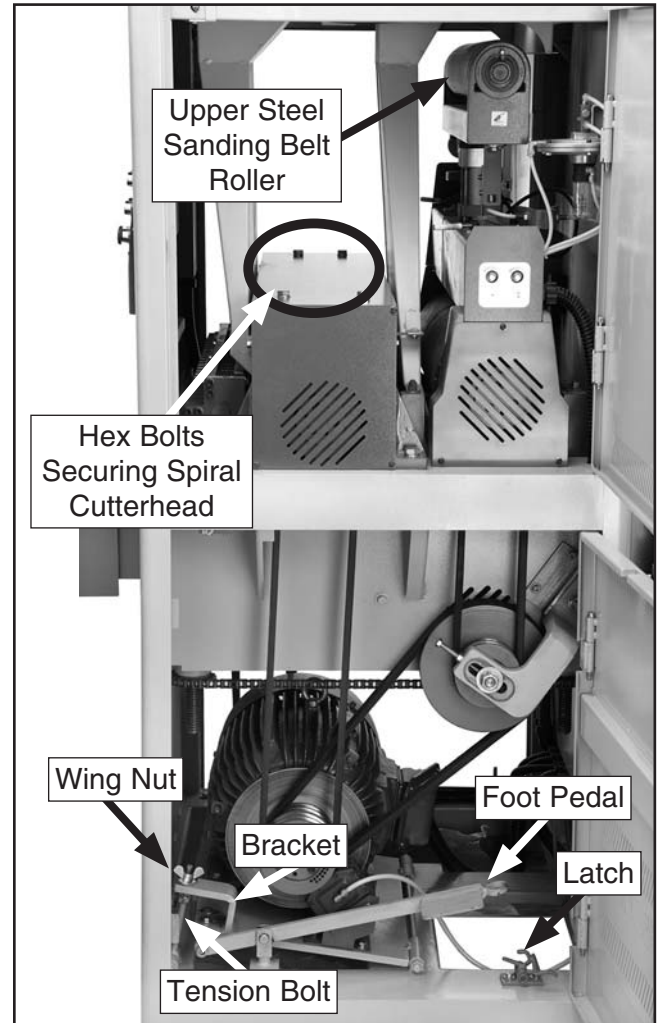

Figure 10. Access to cleaning locations.

To access the spiral cutterhead:

1. Open the lower right access door, loosen the large wing nut on the tension bolt (**Figure 10** on **Page 15**) then move the nut, bolt, and lock nut out of the way.
2. Push the foot pedal down to loosen the V-belts, then lock the foot pedal in place with the latch (see **Figure 10**).
3. Remove the two V-belts on the spiral cutterhead pulley.
4. Using a 19mm wrench or socket, remove the four hex bolts and lock washers that secure the spiral cutterhead assembly (**Figure 10**), grip the handle on the left side, then slide the cutterhead assembly all the way out (**Figure 11**).



Figure 11. Spiral cutterhead access.

5. Put on heavy leather gloves and clean thoroughly, taking care not to cut your hands on the carbide inserts.
6. Slide the cutterhead assembly back into the cabinet, secure it with the hex bolts and washers removed earlier, then re-install the V-belts.
7. Press down on the latch to unlock the foot pedal and re-engage the V-belt tension.
8. Insert the tension bolt and wing nut into the groove on the bracket, tighten, then close and latch all access panels and doors.

Site Considerations

Floor Load

Refer to the **Machine Data Sheet** for the weight and footprint specifications of your machine. Some residential floors may require additional reinforcement to support both the machine and operator.

Placement Location

Consider existing and anticipated needs, size of material to be processed through each machine, and space for auxiliary stands, work tables or other machinery when establishing a location for your new machine. See **Figure 12** for the minimum working clearances.

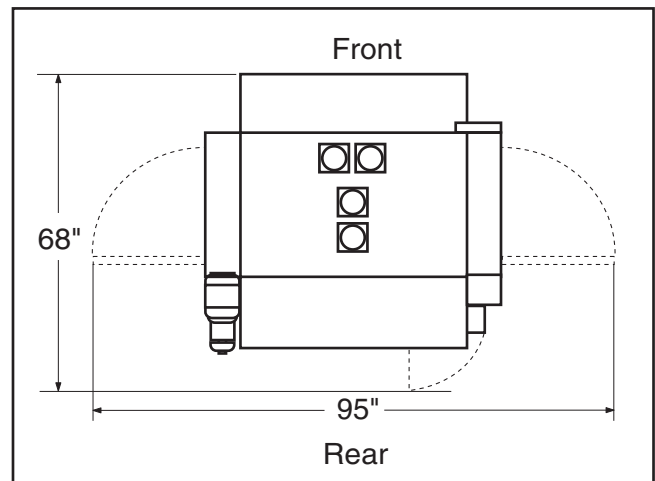
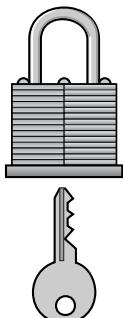
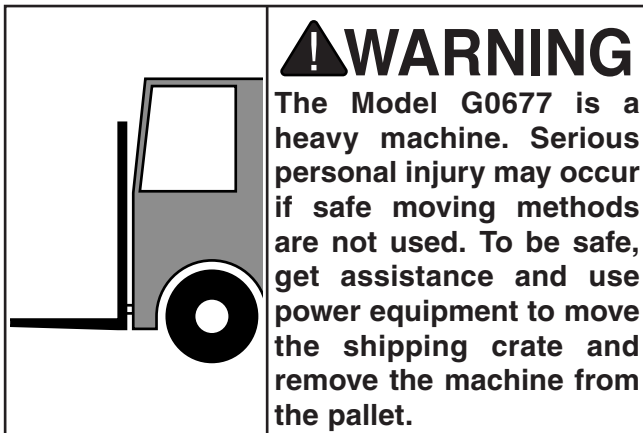

Figure 12. Minimum working clearances.

	<p>⚠ CAUTION</p> <p>Children and visitors may be seriously injured if unsupervised around this machine. Lock entrances to the shop or disable start switch or power connection to prevent unsupervised use.</p>
--	--

Moving & Placing Planer/Sander



To move and place your planer/sander:

1. Remove the crate from the shipping pallet.
2. Open the lower access doors and use a 14mm wrench to remove the four hex bolts and flat washers that secure the planer/sander to the pallet.
3. Using a forklift (**Figure 13**), lift the machine just enough to clear the pallet and floor obstacles, then move it to the prepared location.

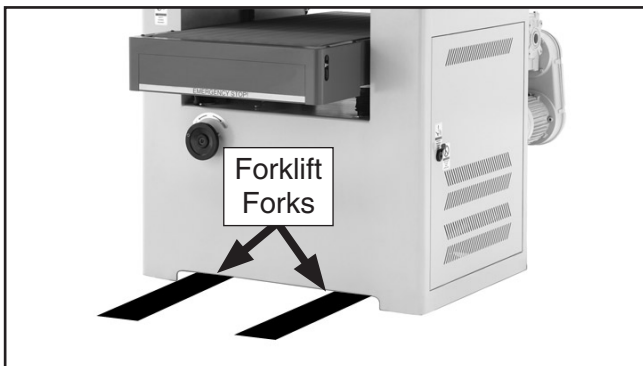

Figure 13. Lifting the planer/sander.

4. When mounting the machine to the floor (optional), use a precision level to make sure it is level from side-to-side and front-to-back.
5. If necessary, use shims to make sure there are no gaps between the base and the floor and to avoid warping the steel frame.

Mounting to Shop Floor

Although not required, we recommend that you mount your new machine to the floor. Because this is an optional step and floor materials may vary, floor mounting hardware is not included. Whichever option you choose, it is necessary to level your machine with a precision level and, if necessary, shim between the base and floor to avoid warping the steel frame.

Bolting to Concrete Floors

Lag shield anchors with lag bolts and anchor studs (**Figure 14**) are two popular methods for anchoring an object to a concrete floor. We suggest you research the many options and methods for mounting your machine and choose the best that fits your specific application.

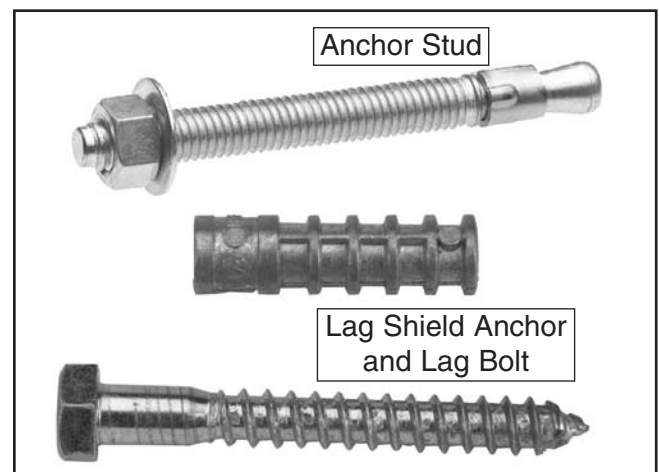

Figure 14. Typical fasteners for mounting to concrete floors.

NOTICE

We strongly recommend securing your machine to the floor if it is hardwired to the power source. Consult with your electrician to determine if this is appropriate for your setup.

Air Hose

To install the air line:

1. Connect the air inlet (**Figure 15**) on the regulator to a compressed air line.

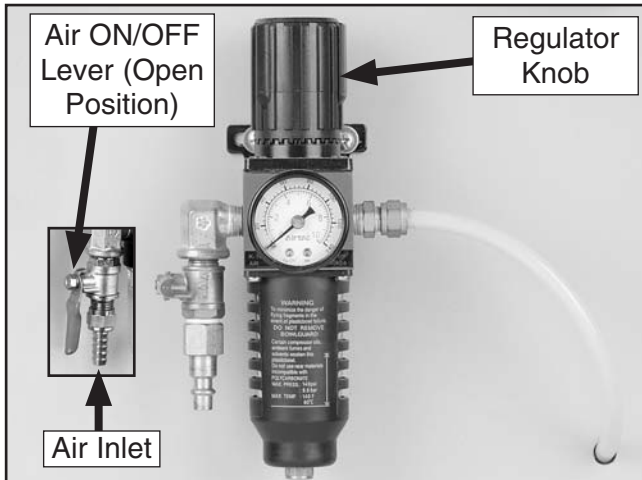

Figure 15. Air hose attached to regulator.

2. Make sure the red ON/OFF handle on the regulator is in the open position.
3. Lift the regulator knob (**Figures 15 & 16**) and rotate it until the gauge reads 75 PSI.

Note: Rotate the knob clockwise to increase the air pressure and counterclockwise to lower the air pressure.

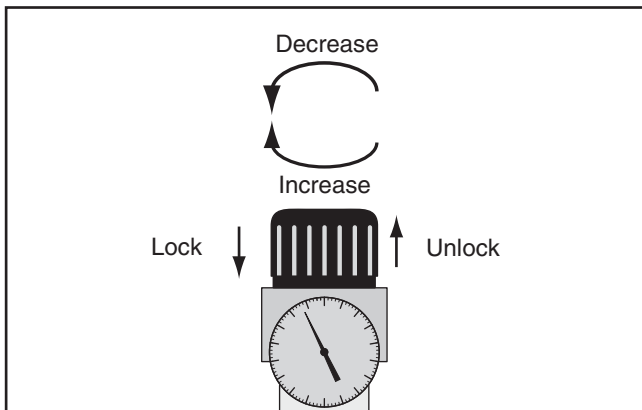

Figure 16. Regulator knob.

4. Push the knob down until it snaps to lock it.

Dust Collection

An efficient and clean dust collection system is essential to the proper function of the planer/sander. Ensuring a healthy work environment is also dependent upon cleaning and maintaining your dust collection system. We recommend connecting this planer/sander to a cyclone dust collector rather than a bag type dust collector, since a cyclone will handle fine dust particles better and experience fewer clogging problems.

Recommended CFM @ Machine: 2500 CFM

Do not confuse this CFM recommendation with the rating of the dust collector. To determine the CFM at the dust port, you must consider these variables: (1) CFM rating of the dust collector, (2) hose type and length between the dust collector and the machine, (3) number of branches or wyes, and (4) amount of other open lines throughout the system. Explaining how to calculate these variables is beyond the scope of this manual. Consult an expert or purchase a good dust collection "how-to" book.

⚠ WARNING

DO NOT operate this machine without an adequate dust collection system and a respirator. This machine creates substantial amounts of wood dust while operating. Failure to use a dust collection system can result in short and long-term respiratory illness.

Using 5" hose clamps, secure the hoses from your dust collection system to the pre-installed dust ports.

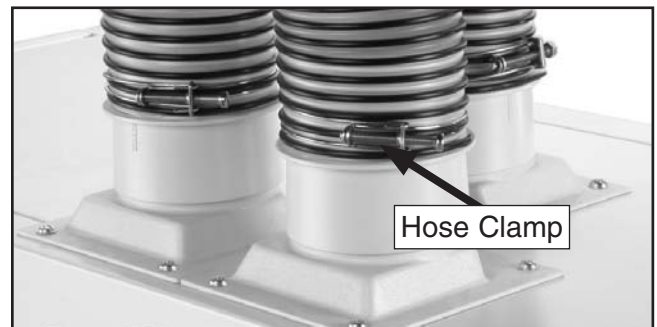

Figure 17. Example of dust collection hose attached to dust port.



Sanding Belt

To install the sanding belt:

1. With the machine connected to air, turn the belt tension knob to the 9 o'clock position.
2. Remove the lock post release lever (**Figure 18**) by turning it counterclockwise a $\frac{1}{2}$ turn and pulling it up and out of the mounting hole.
3. Remove the spacer block (**Figure 18**).

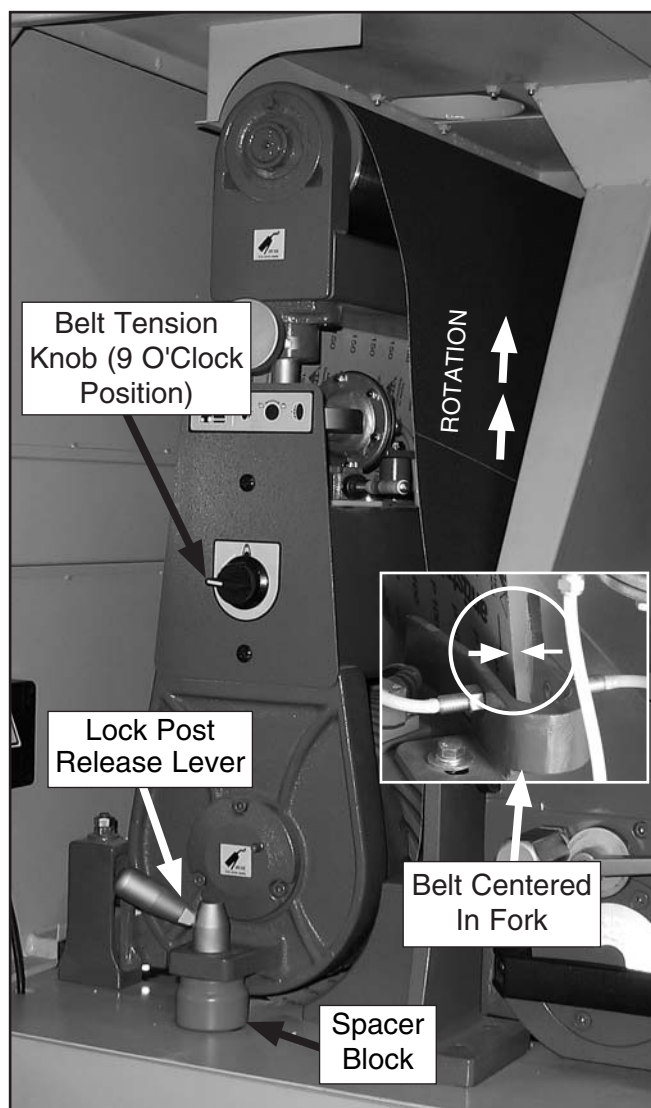

Figure 18. Components used when changing a sanding belt.

4. Making sure the rotation arrows on the sanding belt point the same direction as those shown in **Figure 18**, install the sanding belt by starting first on the upper roller and then the lower roller.

Note: The sanding belt must be centered between the limit switches, and the edge of the sanding belt must be between the tongs of the belt oscillation controller fork, as shown in **Figures 18 & 19**. Damage to the sanding belt and sander will occur if the sander is turned **ON** before the sanding belt is correctly positioned.

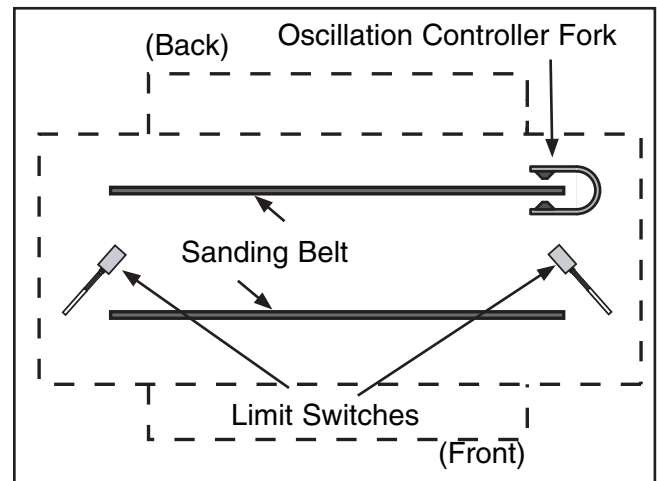

Figure 19. Sander outline (top view). Proper position of belt between the limit switches.

NOTICE

The directional arrow on the back of the sanding belt must be pointing in a counterclockwise direction during installation. Failure to install the sanding belt correctly could result in damage to the sanding belt or the sander itself.

5. Replace the spacer block and tighten down the lock post release lever.
6. With your hands clear of all moving parts, turn the belt tension knob to the 12:00 position to tension the belt.

—If the belt tension knob is turned to the 9:00 position, the belt will have no tension.

Pressure Roller Height

The pressure rollers have been set at the factory, but for safety, you should verify that they are set below the level of the sanding roller.

WARNING

The pressure rollers must be set below the level of the sanding roller. If the pressure rollers are even, or higher than the sanding roller, the wood WILL be propelled from the machine at a high rate of speed toward the front of the machine. This could cause serious kickback injury.

To check the pressure roller height:

1. DISCONNECT THE PLANER/SANDER FROM THE POWER SOURCE!
2. Place a 20" long 2x4 of uniform thickness across one side of the table so it spans both the front and rear pressure rollers at the same time (see **Figure 20**).



Figure 20. Checking pressure roller height.

3. With the air pressure connected and the sanding belt installed and tensioned, manually raise the table and verify that the board touches both pressure rollers before it touches the sanding belt.
4. Repeat **Step 3** on the other side of the conveyor table.

Note: If the board did not touch both pressure rollers before it touched the sanding belt on either side, or if it was difficult to place the board between the rollers and the table on in **Step 4**, then the pressure rollers **MUST** be adjusted before operation. See "**Pressure Rollers**" on **Page 49** for step-by-step instructions.

Gear Box Oil

It is critical that you make sure there is oil in the feed belt gear box before proceeding with the test run. Refer to the **Lubrication** instructions on **Page 37** for more details on which type of oil to use, how much to use, and where to put it.



To check the feed belt gear oil:

1. Check the sight glass shown on the back of the gear box with a mirror, as shown in **Figure 21**, to make sure gear oil is present.

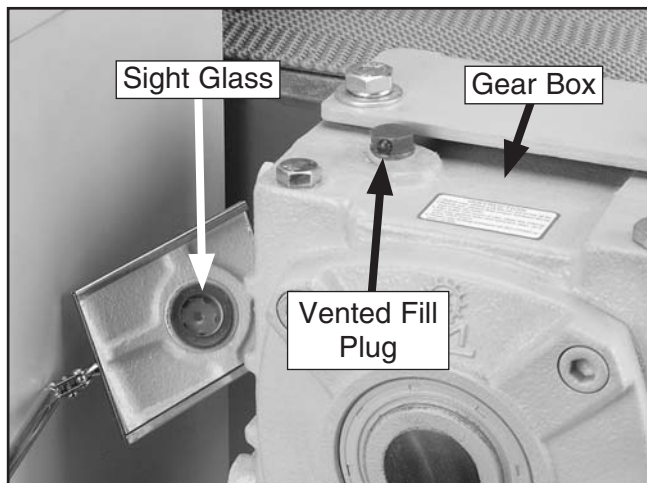

Figure 21. Sight glass location on gear box.

2. If the gear box oil level is below the sight glass level, follow the steps on **Page 37** to refill the oil.

Breather Pin

The Model G0677 is shipped with a breather sealing pin installed in the fill plug for the feed belt gear box.

Remove this pin before using your machine (see **Figure 22**); otherwise, the gear oil will expand with heat and the seals in the gear box may leak due to the pressure buildup.

You may want to keep this pin if you plan on storing your machine for a long period of time.

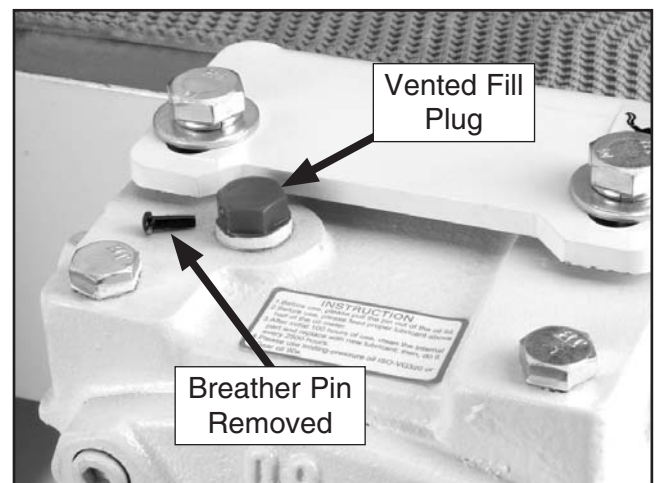

Figure 22. Breather sealing pin removed.

Test Run

Once the assembly is complete, test run your machine to make sure it runs properly and is ready for regular operation.

The test run consists of verifying the following: 1) The motor powers up and runs correctly, 2) the front and rear stop buttons work correctly, 3) the feed belt motor turns the correct direction (machine is not wired out of phase), and 4) the door safety limit switches work correctly.

If, during the test run, you cannot easily locate the source of an unusual noise or vibration, stop using the machine immediately, then review **Troubleshooting** on **Page 39**.

If you still cannot remedy a problem, contact our Tech Support at (570) 546-9663 for assistance.

Before beginning the test run, review the basic power controls in **Basic Controls**, beginning on **Page 24**.

!WARNING

Before starting the planer/sander, make sure you have performed the preceding assembly and adjustment instructions, and you have read through the rest of the manual and are familiar with the various functions and safety features on this machine. Failure to follow this warning could result in serious personal injury or even death!

To test run the machine:

1. Make sure you understand the safety instructions at the beginning of the manual and that the machine is setup properly.
2. Make sure all tools and objects used during setup are cleared away from the machine, and close all panels and access doors.
3. Make sure the machine is connected to an air compressor and the pressure gauge reads 75 PSI.
4. Make sure all wiring is correct.

5. Put on your safety glasses.
6. Connect the machine to the power source.
7. Push the front and rear STOP buttons in, then twist them clockwise so they pop out. When the STOP buttons pop out, the switches are reset and ready for operation (see **Figure 23**).

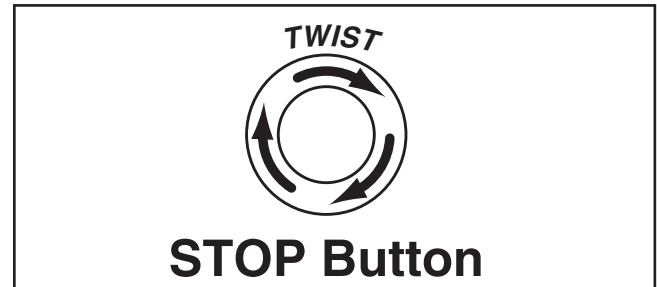

Figure 23. Resetting the switch.

8. Verify that the power is not connected out of phase by pressing the TABLE UP and TABLE DOWN keys (see **Figure 26, Page 25**), using the criteria below:

—If the table moves in the same direction as the button description, the machine is wired correctly.

—If the table moves in the opposite direction to the arrow on the button, the power is connected out of phase.

Stop the machine, DISCONNECT THE POWER, then swap the L1 and L2 wires at the terminal connection (see **Figure 24**).

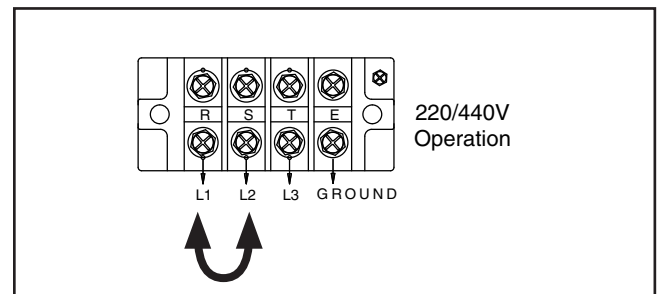

Figure 24. Example of switching wires at power supply terminal connection.



9. Press the FEED BELT START then the FEED BELT STOP buttons (see **Figure 25, Page 24**). The feed belt should start, run in the correct direction and stop smoothly.

10. Press the SANDING BELT START then the SANDING BELT STOP buttons. The sanding belt should start, run in the correct direction, and stop smoothly.

—When operating correctly, the machine runs smoothly with little or no vibration or rubbing noises.

However, you will hear an air leaking sound from the oscillation controller fork jet (**Figure 19**).

—Investigate and correct strange or unusual noises or vibrations before operating the machine further. Always stop the machine and disconnect it from power before investigating or correcting potential problems.

11. Press the front STOP button to stop the machine.

12. WITHOUT resetting the switch, press the FEED BELT START button. The machine should not start.

—If the machine does not start, the STOP button safety feature is working correctly.

—If the machine does start (with the STOP button pushed in), immediately disconnect power to the machine. The STOP button safety feature is not working correctly. This safety feature must work properly before proceeding with regular operations. Call Tech Support for help.

13. Reset the STOP button.

14. Press the rear STOP button and repeat **Steps 12–13**.

15. Press the FEED BELT START button, then press the emergency stop plate. The sander will come to a complete stop.

—If the feed belt does not come to a complete stop, the emergency stop plate is not working correctly. Call Tech Support for help.

G0677 24" Planer/Sander

16. Unlock and slightly open the right and left access doors until you hear a "click," indicating that the door limit switches have been triggered.

—If the machine does not start, the door limit safety switches are working correctly.

—If the machine does start, immediately disconnect power to the machine. The door limit switches are NOT working correctly. This safety feature must work properly before proceeding with regular operations. Call Tech Support for help.

Recommended Adjustments

For your convenience, the adjustments listed below have been performed at the factory and require no further adjustment. However, we recommend that you verify that the adjustments are correct and to your satisfaction.

Recommended adjustment checklist:

1. Pressure Rollers (**Page 20**).
2. Oscillation Speed (**Page 27**).
3. Air System (Air Regulator to 75 PSI; **Page 38**).
4. Table Calibration (**Page 42**).
5. Belt Tracking (**Page 44**).
6. Table Parallelism (**Page 46**).
7. V-Belt Tension (**Page 50**).
8. Feed Belt Tension (**Page 57**).
9. Feed Belt Tracking (**Page 57**).



SECTION 4: OPERATIONS

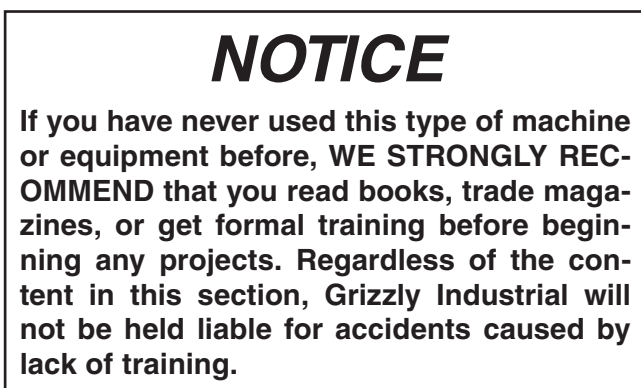
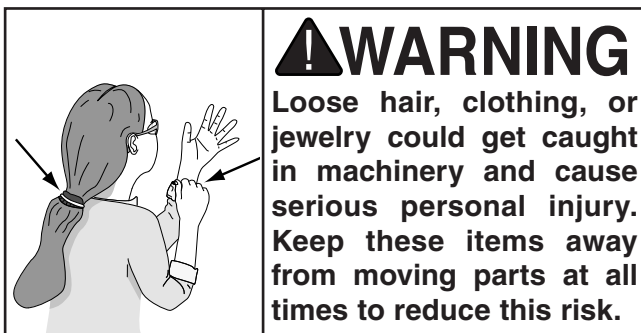
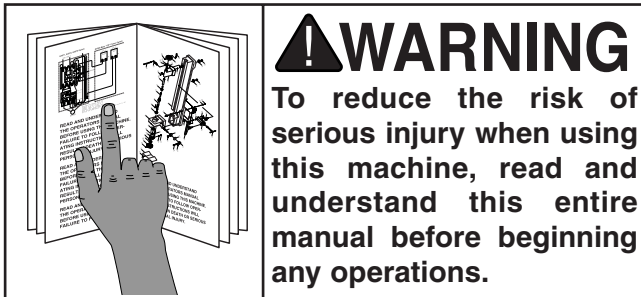

Basic Controls

Refer to **Figures 25–28** and the descriptions below to become familiar with the basic controls and components of your planer/sander.

Control Panel

Amp Load Meter: Indicates the current amp load on the main motor when a planing and sanding operation is in progress.

Sanding Belt Start and Stop Buttons: Turns the sanding motor **ON** and **OFF** if the planer/sander has air pressure, the belt is tensioned, the power is connected, and all access doors are closed and locked.

Feed Belt Start and Stop Buttons: Cycles the feed belt motor **ON** and **OFF** for feeding wood into the planer/sander.

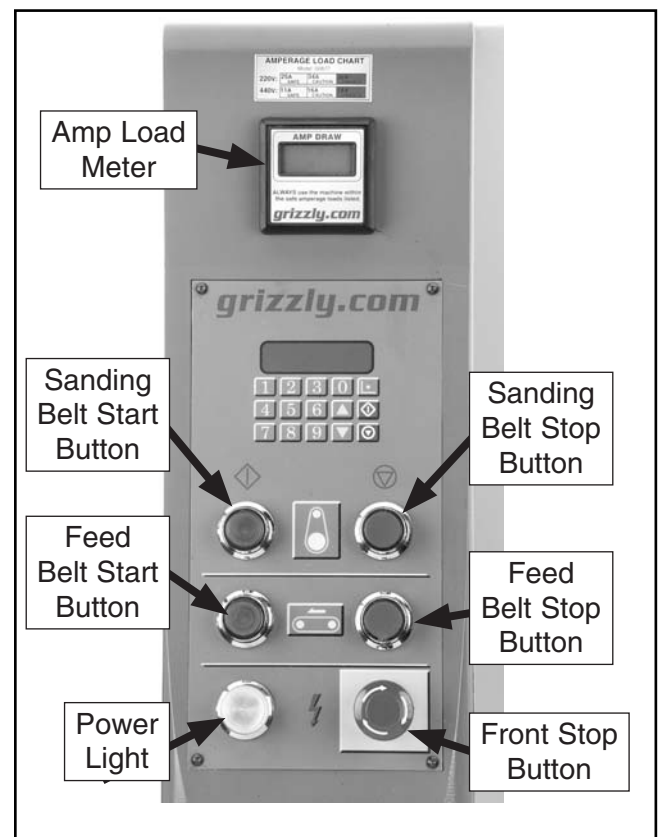

Figure 25. Control panel.



Front Stop Button: Stops all electrical power to motors in the event of an emergency, and stops the sanding drum with an air-disc brake.

Power Light: Indicates the machine is connected to power.

Digital Controls

Digital Table Height Key Pad (see **Figure 26**): This controls motorized table height adjustments. To use the display, the power must be **ON**, air must be connected, both stop switches must be reset, and all access doors must be closed and locked.

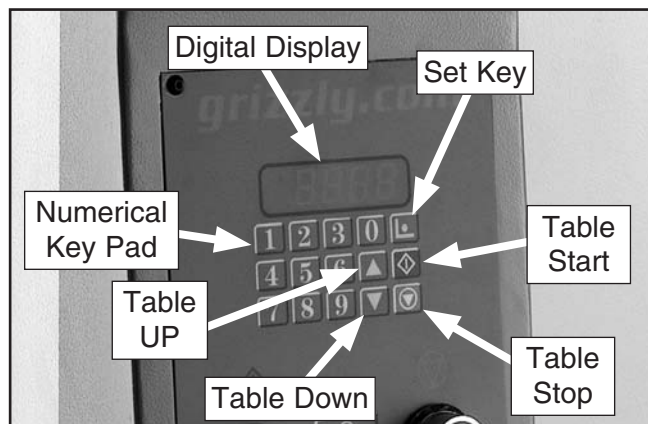















Figure 26. Digital table height key pad.

- **Digital Display:** This window shows the current table position from the sanding drum (i.e. workpiece thickness).
- **Set Key:** Use to calibrate table position or switch between standard/metric display. To calibrate the display at the current board thickness, enter the thickness, then press and hold the  key for 3 seconds (refer to **Page 42** for further detail). To toggle the display between metric and standard measurement, press and hold the  key for 10 seconds.
- **Table Start Key:** Activates the table to move to the position entered through the keypad. Enter the desired thickness the workpiece the using the key pad, then press the  key. The table will move to the depth you entered.

- **Table Stop Key:** Stops table and cancels key pad entry. Press the  key to immediately stop the table if it is moving up or down. If you enter the wrong depth of cut value in the digital display, press the  key to clear and reset it to current table position.
- **Table Up and Down Keys:** Press the  or key  to quickly raise or lower the table in 0.005" (0.125mm) increments—to fit the workpiece between the cutterhead/sanding drum and the table. Or press these keys to incrementally raise the workpiece during planing and sanding operations. Refer to **Page 29** for instructions on planing and sanding workpieces.
- **Numerical Key Pad:** Allows operator to enter a specific table height. Press the 0–9 keys as needed to enter the desired thickness of your workpiece. The display will flash until you press the  key.

Example: If your input is 2.15", then you would press the following keys:    , then press the  key. The table will move to that height.

Additional Controls

Table Height Handwheel: Manually raises or lowers the conveyor table in increments less than 0.005" to fine-tune the sanding depth. One full turn of the handwheel changes the height of the table 0.020."

Plate: Stops electricity to the motors and applies an air-disc brake to stop the planer/sander immediately.

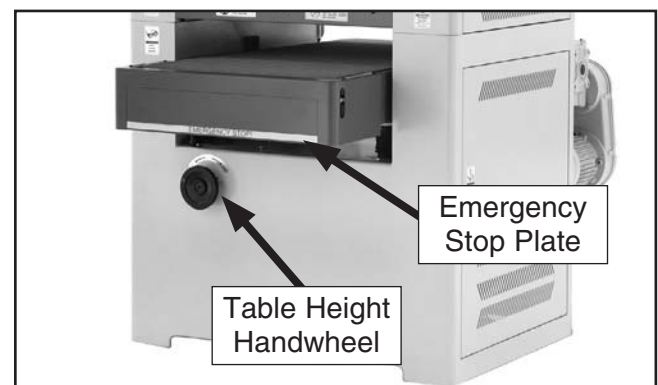

Figure 27. Additional front controls.

Variable Feed Rate Dial: Adjusts the feed rate between 14 and 60 FPM.

Rear Stop Button: Immediately stops all electrical power to the motors in the event of an emergency and stops the sanding drum with an air-disc brake.

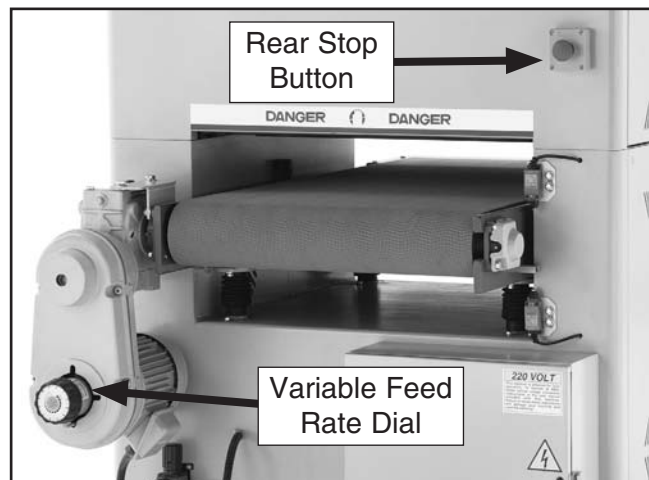

Figure 28. Rear controls.

Cutterhead Adjustment Shaft (Figure 29): Raises and lowers the spiral cutterhead above the table and in relationship to the height of the rear sanding drum. Use an adjustable wrench to turn the shaft.

Cutterhead Lock Handle: Locks the cutterhead in place so it will not move. Loosen to allow cutterhead height adjustment. Lock after setting cutterhead position.

Cutterhead Height Scale: Indicates the cutterhead height relative to the sanding drum; measured in 0.004" in (0.10mm) increments. We recommend setting the cutterhead at 0mm for most operations.

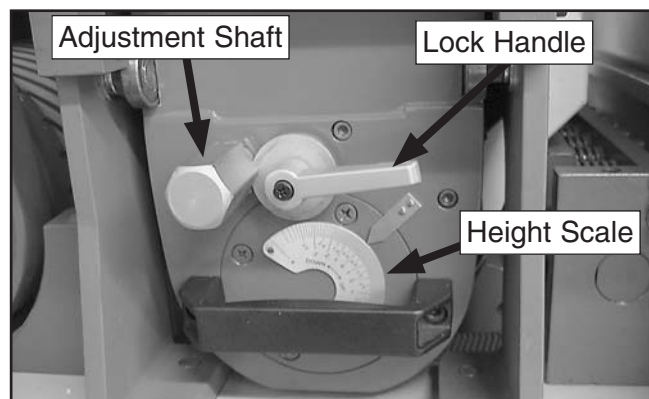

Figure 29. Planer cutterhead controls.

Adjusting Feed Rate

The dial attached to the side of the feed motor cover (**Figure 28**) adjusts the feed rate of the sander.

Changing the Feed Belt Speed

1. Start the feed belt.
2. Turn the dial clockwise to decrease the feed rate and counterclockwise to increase it.

Note: *Never adjust the feed rate dial unless the feed belt is running or you can damage the control.*

Determining Ideal Feed Rates

Softwoods typically require a faster feed rate than hardwoods; however, there is no definitive rule to follow when determining the best feed rate. As a general rule, always start with the slowest feed rate and work your way up. We always recommend testing the feed rate using scrap wood similar to your workpiece. Be sure to monitor the amperage meter (see **Page 28**) when adjusting the feed rate. Decrease the feed rate if the load begins to slow the motor RPM.

Oscillation Speed

The oscillation speed of the sanding belt is adjustable. Different oscillating speeds yield different sanding results. We recommend trying various speeds on a scrap piece of wood similar to the workpiece being used. The oscillation speed is measured by how long it takes the belt to move from one side to the other.

Tools Needed	Qty
Wrench 9mm	1

To adjust the oscillation speed:

1. Loosen the lock nut on the speed control adjustment knob (**Figure 30**).

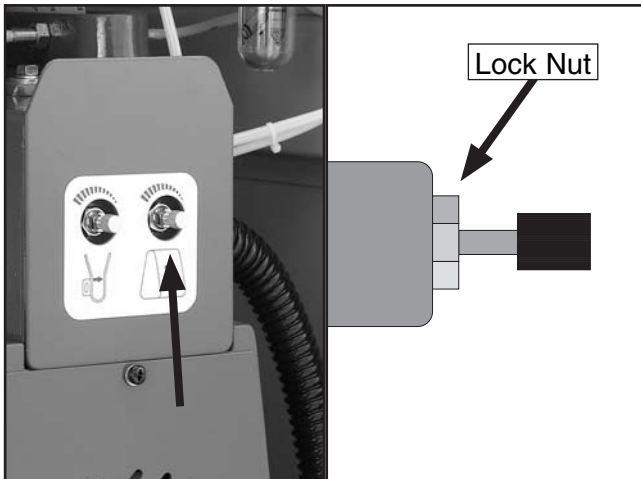

Figure 30. Speed control adjustment knob.

2. Turn the knob clockwise to decrease the oscillation speed and counterclockwise to increase it.

Note: To re-establish the factory setting, back out the knob until it stops, then turn it $3\frac{1}{2}$ turns.

3. Tighten the lock nut loosened in **Step 1** to secure the knob.

As you experiment with different oscillation speeds, make a note of the timing from one side to the other when you find the best sanding results. That way you can readjust the oscillation speed later if sanding that type of material again.

Choosing Sandpaper

When selecting sandpaper, keep in mind that the Model G0677 accepts only 25" wide by 60" long belts. The grit you choose will depend on the type of work, the species of wood and the stage of finishing. When choosing which sandpaper to use, use these grit numbers as a general guide to sandpaper type:

Grit	Type
60 or less	Coarse
80-100	Medium
120-150	Fine

We recommend using aluminum oxide sanding belts for best results. The general rule of thumb is to sand a workpiece with progressively higher grit numbers, with no one grit increase of more than 50; however, the type of wood and desired finish will determine the best grit to use. **Note:** Sandpaper finer than 150 grit can often load up or burn workpieces.

Sanding Belt Replacement

To replace the sanding belt:

1. Follow **Steps 1–3** on **Page 19**.
2. Remove the sanding belt.
3. Making sure the rotation arrows on the sanding belt point the same direction as those shown in **Figure 18** on **Page 19**, install the new sanding belt by starting first on the upper roller, and then the lower roller.

Note: The sanding belt must be centered between the limit switches and the edge of the sanding belt must be between tongs of the oscillation controller as shown in **Figure 18** on **Page 19**. Damage to the sanding belt could occur if the sander is turned **ON** before the sanding belt is correctly positioned.



NOTICE

The directional arrow on back of the sanding belt must be pointing in a counterclockwise direction during installation. Failure to install the sanding belt correctly could result in damage to the sanding belt or the sander itself. If your belt does not have arrows, it is most likely unidirectional, so it will not matter which direction it is installed.

4. Follow Steps 5–7 on Page 19.

Amp Load Meter

The amperage load meter (**Figure 31**) is used to keep the machine from being overloaded during planing/sanding operations.

As a general rule, always start with a small load and work your way up. DO NOT work your machine to its maximum load or where you can hear the motor lose RPM; instead, make multiple light passes or install a coarser grit sandpaper.

Amp load will be directly affected by many factors such as feed rate, depth of cut, wood type, sandpaper grit, and workpiece width. If the amp load is in the red load range, the machine is overloaded and motor damage may soon occur. Use the amp load chart near the meter to keep the amp load in the green SAFE range during operation.

NOTICE

DO NOT VOID WARRANTY! Keep amp draw within GREEN load range shown on the AMP LOAD CHART. If you operate machine in RED load range motor damage may occur and will not be covered under warranty.

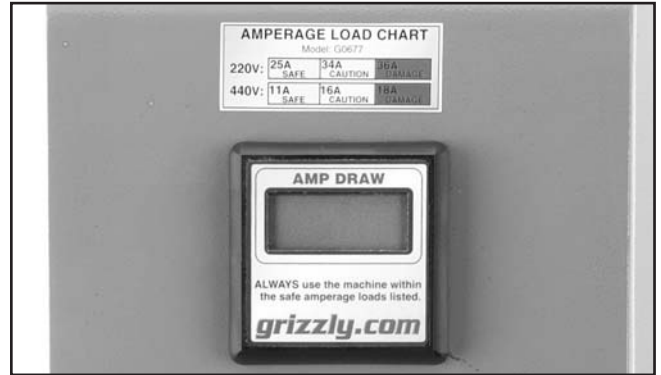

Figure 31. Model G0677 amp draw meter and load chart.

Emergency Stop Plate

To use the emergency stop plate (**Figure 32**), push and hold it until the sander has come to a complete stop.



Figure 32. Emergency stop plate.

CAUTION

KEEP the cutterhead and sanding drum V-belts correctly tensioned (refer to Page 50). Otherwise, the pulleys will slip when the emergency brake is applied and not immediately stop the machine in the event of an emergency!

Planing/Sanding

The Model G0677 is capable of planing and sanding or sanding only. To achieve the best results, experiment with conveyor feed rate, cutterhead depth, sanding depth, various grits of sandpaper, and oscillation speed. Also, for best results make sure the workpiece has been surface planed on a jointer before planing and sanding.

A typical planing and sanding pass will remove up to $\frac{1}{8}$ " of material. However, attempts to remove too much material can cause jamming, wood burning, rapid sandpaper wear or tearing, poor finish, short motor life, and belt slippage. The operator usually makes a pass, raises the table a little, and repeats until the entire surface is both planed and sanded.

Typically, no more than 0.5mm (approx. 0.020") of material is removed during a sanding only pass. The maximum sanding depth also depends upon the thickness of the sanding belt, which can vary from 0.010" (fine sandpaper) to 0.060" (coarse sandpaper).

Planing and Sanding Workpieces

1. DISCONNECT THE PLANER/SANDER FROM THE POWER SOURCE!
2. Open the upper left access door.
3. Make sure the cutterhead is set at the 0mm position on the height scale. If not, loosen the cutterhead lock handle, turn the cutterhead adjustment shaft to the 0mm position on the scale, then tighten the lock handle.

Note: We recommend setting the scale at 0mm for most planing/sanding operations.
4. Close and lock the left access door.
5. Make sure you have reviewed the **Workpiece Inspection** on **Page 33**.
6. Put on safety glasses, a dust mask, and hearing protection!
7. Make sure the machine is connected to power and compressed air, and turn the dust collector **ON**.

8. Raise or lower the table until the workpiece is approximately $\frac{1}{8}$ " (0.125") below the sanding belt.

To do this: Measure the workpiece thickness, then add $\frac{1}{8}$ ", then fine tune with the handwheel or the arrow keys.

9. Push the SANDING BELT START button, then push the FEED BELT START button.
10. Stand to the side of the feed belt to reduce the risk of kickback, feed the workpiece into the machine (see **Figure 33**), then raise the table with the handwheel until the machine begins planing and sanding the workpiece.

As the workpiece passes through the machine, you should hear the cutterhead cut and the sanding belt sand the workpiece.



Figure 33. Operator feeding workpiece at correct body position and out of the way of potential kickback.

11. Remove the workpiece from the outfeed side of the machine.
12. Inspect the workpiece.

—If the workpiece is flat and smooth, shut the planer/sander **OFF**.

—If the workpiece is rough to the touch, repeat with additional passes until it is smooth.

—If repeated passes through the machine do not yield the desired result, the cutterhead may be too low and the sanding belt may not be contacting the workpiece. Try raising the cutterhead incrementally 0.1mm between passes and continue feeding the workpiece through until it is smooth.

Sanding Workpieces

To sand workpieces:



1. DISCONNECT THE PLANER/SANDER FROM THE POWER SOURCE!
2. Unlock and open the upper left access door.
3. Note the current setting on the planer cutterhead height scale.
4. Loosen the lock handle, turn the adjustment handle up to the 2mm position (**Figure 34**) to raise the cutterhead out of the way—so it will not contact the workpiece—then tighten the lock handle to secure the cutterhead.



Figure 34. Spiral cutterhead raised to 2mm position on height scale.





5. Close and lock the upper left access door.
6. Make sure you have reviewed **Workpiece Inspection** on **Page 33**.
7. Make sure the machine is connected to power and compressed air, and turn the dust collector **ON**.

8. Raise or lower the table until the workpiece is approximately 1/8" (0.125") below the sanding belt.

To do this: Type a specific table height with the numeric keypad, then press the Table Start key  to lower the table to that height. Then turn the table height handwheel, or press the Table Up  and Down  keys as needed to adjust the table height in 0.005" (0.125mm) increments until the workpiece is 1/8" below the sanding belt.

9. Put on safety glasses, a dust mask, and hearing protection!
10. Push the SANDING BELT START button, then push the FEED BELT START button.
11. While standing to the side of the feed belt—to reduce injury from kickback, feed the workpiece into the machine (see **Figure 33** on **Page 29**), then raise the table with the handwheel until it begins sanding the workpiece.
12. Remove the workpiece from the outfeed side of the machine.

—If the machine did not sand the workpiece on the first pass, repeat **Step 11** until the machine begins to sand the entire workpiece.

13. As you sand, observe the amp draw meter, and press the table down key  to reduce the sanding depth if the amp load meter indicates motor overload, or reduce the feed rate.
14. Re-sand the workpiece a couple of times more at the same depth to ensure a consistent sanding depth, then feed it through one final time without adjusting the depth of cut.
15. To add a new sanding depth, press the Table Up  and Down keys , or enter a specific table height with the numeric keypad and press the Table Start key  to raise the table to that height.



Planing Workpieces

We do not recommend only planing workpieces with the Model G0677. Doing so will yield a rougher, unfinished workpiece with some snipe, and increase the risk of kickback at the front of the machine.

If you must plane a workpiece do not set the cutterhead only farther than 0.5mm on the downward part of the height scale, as shown in **Figure 35**. At this point, the cutterhead inserts are approximately even with the sanding drum. Moving it lower than this will only reduce contact the pressure rollers have against the workpiece.



Figure 35. Cutterhead height set for planing.

Poor pressure roller contact will cause the workpiece to get stuck under the outfeed side of the planer/sander, so you will have to manually remove it from the outfeed side of the table. If you attempt to do a "planing" only pass and you notice that the workpiece is not fed completely out of the machine, then adjust the cutterhead upwards by 0.1mm or 0.2mm and retry. Repeat this as necessary.

Rotating Carbide Inserts

Tools Needed:	Qty
Wrench or Socket 19mm	1
T-Handle Wrench T-20	1
Flat Head Torx Screw T-20 M6-1 x 15.....	Varies
Carbide Insert 14 x 14 x 2 (30° Bevel)	Varies
Pneumatic Tool (Optional)	1
Torx Bit T-20 (Optional)	1
Breaker Bar	1
Hammer.....	1

The cutterhead is equipped with 188 indexable carbide inserts. Each insert can be rotated to reveal any one of its four cutting edges. Therefore, if one cutting edge becomes dull or damaged, simply rotate it 90° to reveal a fresh cutting edge (**Figure 36**).

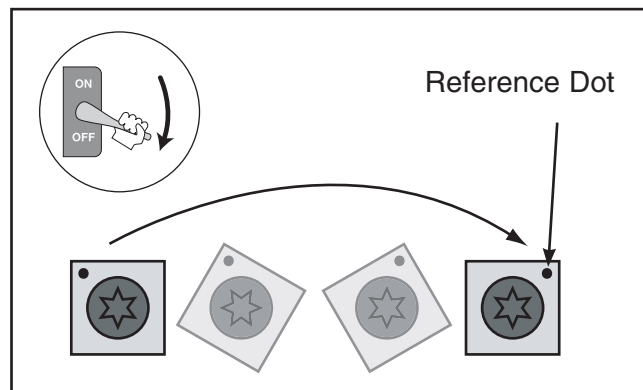

Figure 36. Insert rotating sequence.

In addition, each insert has a reference dot on one corner. As the insert is rotated, the reference dot location can be used as an indicator of which edges are used and which are new. When the reference dot revolves back around to its starting position, the insert should be replaced.

To rotate or change a carbide insert:

1. DISCONNECT THE PLANER/SANDER FROM THE POWER SOURCE!
2. Follow **Steps 1-4** on **Page 16** to access the cutterhead.



3. Remove any sawdust from the head of the carbide insert Torx screw.

4. Remove the Torx screw and carbide insert.

—If the Torx screw is difficult to remove, fit a T-20 bit onto the screw with the included breaker bar, tap it, then turn the bar counterclockwise to loosen the screw.

5. Clean all dust and dirt off of the insert and the cutterhead pocket from which the insert was removed, and replace the insert so a fresh, sharp edge is facing outward. Make sure the insert is seated in the pocket on the cutterhead.

Note: *Proper cleaning is critical to achieving a smooth finish. Dirt or dust trapped between the insert and cutterhead will slightly raise the insert, and make noticeable marks on your workpieces the next time you cut.*

6. Lubricate the Torx screw threads with a light machine oil, wipe the excess oil off the threads, and torque the Torx screw to 48-50 inch/pounds.

Note: *Excess oil may squeeze between the insert and cutterhead or at the bottom of the screw hole, causing hydrostatic lock and preventing the screw from fully tightening, thereby lifting the insert or screw slightly and affecting workpiece finishes.*

—If you are using the included pneumatic tool, connect it to an air supply set at 90 PSI with a coupler appropriate for the air line size. Adjust the air pressure initially to approximately 30 PSI on the pressure gauge, then set the RPM by turning the knurled dial to 2. While holding the insert with your fingers, tighten the Torx screw. Set the air pressure to approximately 85 PSI, but do not change the RPM. Torque the screw again to final tighten it.

7. Repeat **Steps 6-8** on **Page 16**.

Sanding Tips

- Replace the sandpaper with a higher grit to achieve a finer finish (refer to **Choosing Sandpaper** on **Page 27**).
- When making multiple passes on the workpiece, avoid raising the conveyor table more than 0.015" (nearly one turn of the height handle) per each pass.
- Reduce snipe when sanding more than one board of the same thickness by feeding them into the machine with the front end of the second board touching the back end of the first board.
- Feed boards one at a time into the machine at different points on the conveyor to maximize sandpaper life and prevent uneven belt wear.
- DO NOT sand boards less than 12" long, 2" wide and 1/4" thick to prevent damage to the workpiece and the planer/sander (see **Figure 37**).

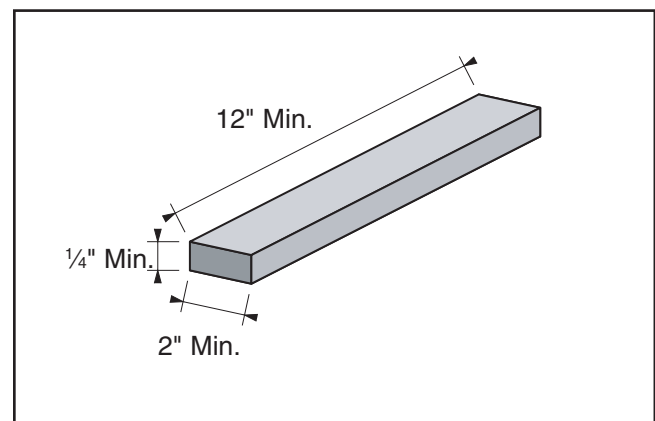

Figure 37. Minimum dimensions for sanding.

- Extend the life of the sandpaper by regularly using a sanding belt cleaning pad (**Page 34**).
- DO NOT edge sand boards. This can cause boards to kickback, causing serious personal injury. Edge sanding boards also can cause damage to the feed belt and sanding belt.

Workpiece Inspection

Some workpieces are not safe or may require modification before they are safe to plane or sand. **Before planing or sanding, inspect all workpieces for the following:**

- **Material Type:** This machine is intended for ONLY cutting natural and man-made wood products. This machine is NOT designed to plane or sand metal, glass, stone, tile, drywall or cementitious backerboard, laminate covered wood products or plastics; cutting these materials with this planer/sander may lead to injury.
- **Foreign Objects:** Nails, staples, dirt, rocks and other foreign objects are often embedded in wood. While planing, these objects can become dislodged and hit the operator, cause kickback, break the inserts, or tear the sanding belt. Always visually inspect your workpiece for these items. If they can't be removed, DO NOT plane or sand the workpiece.
- **Wet or "Green" Stock:** Cutting wood with a moisture content over 20% causes unnecessary wear on the inserts, increases the risk of kickback, and yields poor results.
- **Excessive Warping:** Workpieces with excessive cupping, bowing, or twisting are dangerous to plane because they are unstable and often unpredictable when being cut. DO NOT use workpieces with these characteristics!
- **Minor Warping:** Workpieces with slight cupping can be safely supported if the cupped side is facing the table. On the contrary, a workpiece supported on the bowed side will rock and could cause kickback or severe injury.



SECTION 5: ACCESSORIES

H3741 30 HP Rotary Phase Converter

Add 3-phase, multi-motor capability to your single-phase electrical supply. Operate single or multiple motors, transformers, and resistance loads at 100% power and 95% efficiency while saving big dollars at cheaply metered, single-phase electrical rates. Complete step-by-step instructions are furnished along with complete wire and fusing requirements for various motor loads. Each model operates up to twice its nameplate rating in a mixed-motor load. On heavily loaded or hard-start applications, such as high-speed geared-head lathes and air conditioning compressors, the nameplate rating of the converter you choose should be 2 to 3 times the HP of the most heavily loaded motor. See the individual 3-phase machine pages for phase converter recommendations. For application assistance, please call our technical support at (570) 546-9663.

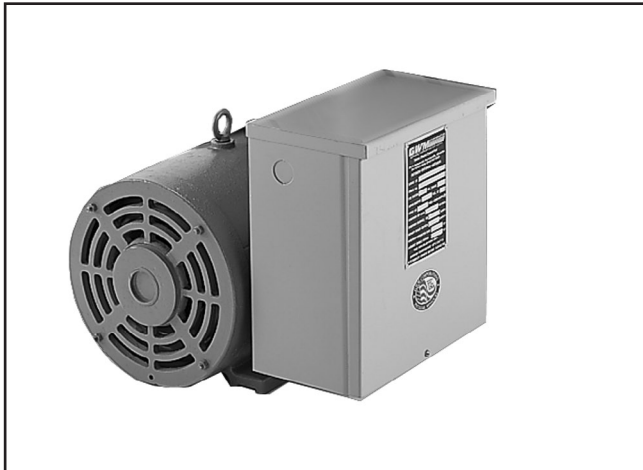

Figure 38. Rotary phase converter.

T20796—Indexable Carbide Inserts for Model G0677

T21277—Front Hood for Model G0677

This dust hood allows you to replace the included ports to consolidate dust collection hose connections. Each hood replaces 2 of the standard dust ports. Buy 2 if replacing all the dust ports included with the machine.

Call 1-800-523-4777 To Order

H9553—Wide-Belt Sander Hood

This dust hood is made to fit over the multiple 4" dust ports on the Model G0677 planer/sander. The base has a 1½" flange on all sides for mounting to the sander. Port has rolled end that connects to similarly sized pipe and fittings.

H2845 Cleaning Pads

Cleaning pads are the perfect accessory for wide belt sanders. Simply set the conveyor table to height and feed the pad through to "unload" a dirty sanding belt. Regular cleaning greatly increases the lifespan of sanding belts. Check with the current Grizzly catalog or www.grizzly.com for more details.

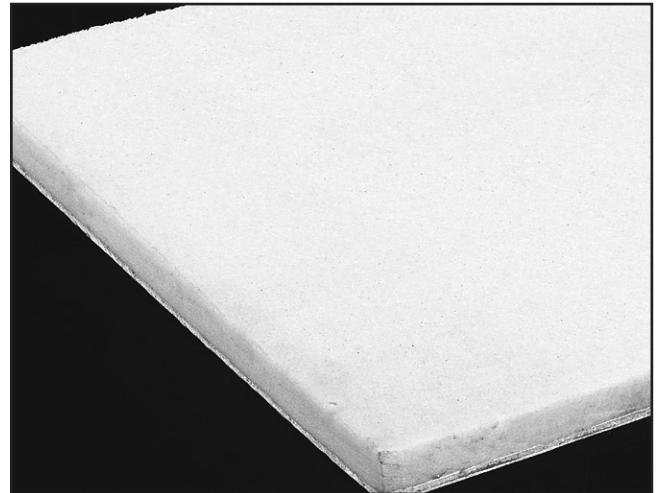

Figure 39. Sanding belt cleaning pad.

US-Made Sanding Belts for Model G0677 25"W x 60"L:

Single Pack

- G8675 60 Grit
- G8676 80 Grit
- G8677 100 Grit
- G8678 120 Grit
- G8679 150 Grit

3-Pack

- H8810 60 Grit
- H8812 80 Grit
- H8813 100 Grit
- H8814 120 Grit
- H8815 150 Grit



SECTION 6: MAINTENANCE



Schedule

For optimum performance from your machine, follow this maintenance schedule and refer to any specific instructions given in this section.

Before Daily Check:

- Check/tighten loose mounting bolts.
- Check/replace worn/damaged sanding belts.
- Check/replace damaged carbide inserts.
- Check for worn or damaged wires.
- Check safety features.
- Check for any unsafe condition.

Weekly Maintenance:

- Drain water in air filter collection cup and empty dust trap bowls (**Page 38**).
- Lubricate grease fittings on feed belt roller axles and sanding belt axles (**Page 36**).

Monthly Check:

- V-belt tension, damage, or wear.
- Clean/vacuum dust buildup from inside cabinet and off motor.
- Grease table elevation screws (**Page 36**).
- Grease table lifting mechanism chain and gears (**Page 36**).

Yearly Check:

- Replace white moisture filters on air regulator.

After First 100 Hours and Every 2500 Hours

- Replace feed belt gear reducer oil (**Page 37**).

Lubrication

An essential step for lubrication is cleaning the components before lubricating them.

This idea is critical because dust and chips build up on lubricated components and make the components hard to move. Simply adding more grease to the components with built-up grime on them will not yield smooth moving components.

Clean the components in this section with mineral spirits.

All other bearings are internally lubricated and sealed at the factory. Simply leave them alone unless they need to be replaced.

The following are the main components that need to be lubricated:

- Grease Fittings
- Table Elevation Screws
- Table Lifting Mechanism
- Feed Belt Gear Box

Schedules are based on average use. Adjust lubrication according to your level of use.



Grease Fittings

Lubricant	Frequency	Qty
NLGI #2 Grease	Weekly	1-2 Pumps from Grease Gun

Wipe the fittings clean with a rag. Attach the included flexible grease gun extension to a grease gun. Add one or two pumps of grease to the grease fittings (**Figure 40 & 41**) located on the feed belt roller axles and the sanding belt roller axles. They are identified with yellow labels.

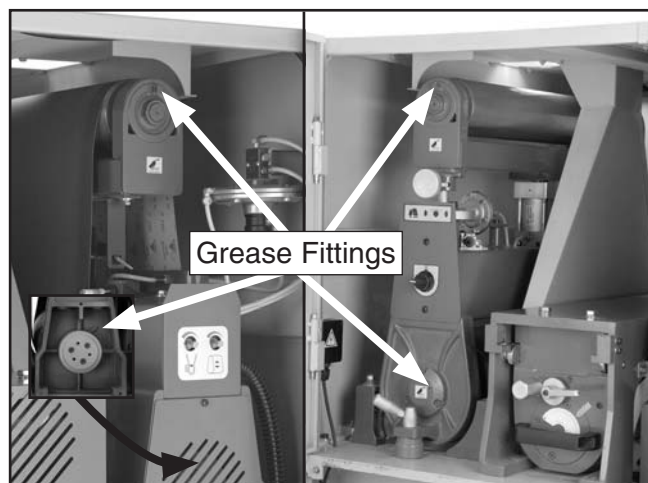

Figure 40. Right/left grease fitting locations.

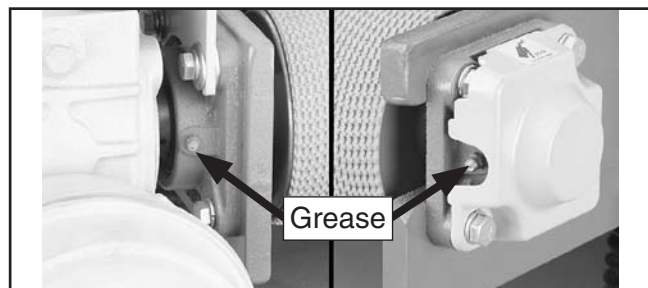

Figure 41. Feed belt roller grease fitting locations.

Table Elevation Screws

Lubricant	Frequency	Qty
NLGI #2 Grease	Monthly	Thin Coat

Pull the dust covers down, and use a shop rag and mineral spirits to wipe away the old lubricant and built-up grime. Brush a thin coat of grease on each table elevation screw (**Figure 42**). Be sure to re-position the dust covers when finished.

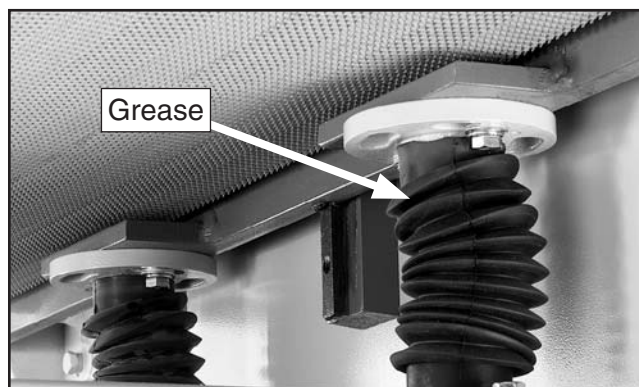

Figure 42. Table elevation screw (shown with dust cover).

Table Lifting Mechanism

Lubricant	Frequency	Qty
NLGI #2 Grease	Monthly	Thin Coat

Open the right access panel and remove the left lower side panel to access the table lifting mechanism. Use a shop rag and mineral spirits to remove the old lubricant and built-up grime. Brush grease onto the chain and gears associated with the table lifting mechanism (**Figure 43**). Be careful to not get grease on the V-belts. This could cause them to slip on the pulleys. If you do get grease on them, replace them.

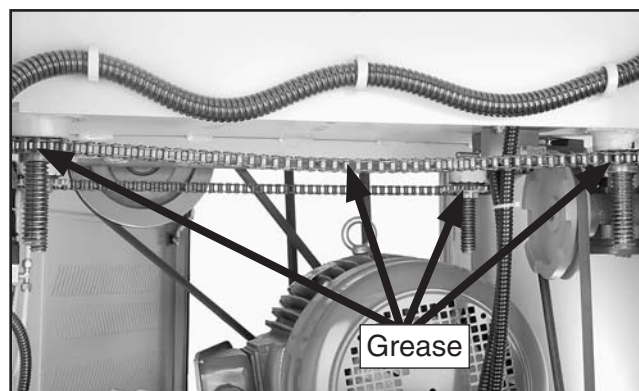

Figure 43. Table lifting mechanism lubrication location.

Feed Belt Gear Box

Lubricant	Frequency	Qty
80-90 Wt. Gear Oil or ISO-VG 320 Oil	After First 100 Hours, then Every 2500 Hours.	As Needed to Fill Above Sight Glass

Replace the feed belt gear box oil (**Figure 44**). We recommend 80-90 Wt. gear oil or ISO-VG320 oil.

To replace the feed belt gear box oil:

1. With the oil and gear box warm, remove the fill plug (**Figure 44**), remove the drain plug, drain the oil, and re-install the drain plug.

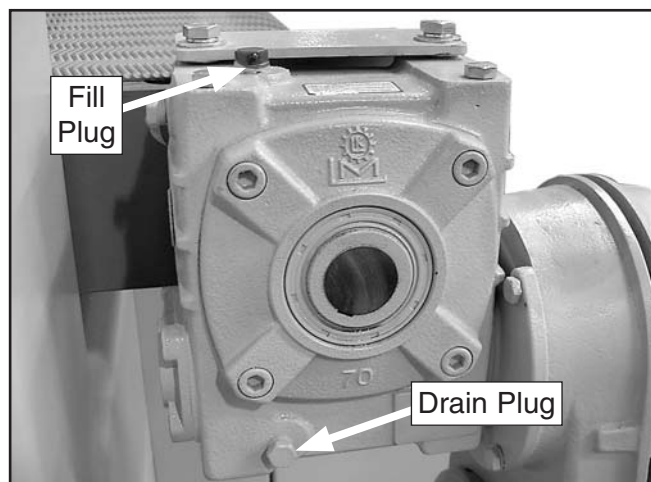

Figure 44. Lubricating gear box.

2. Add new oil and re-install the fill plug.

Cleaning Sanding Belts

To increase the working life of your sanding belts, clean them whenever they decrease in performance due to heavy loading. Use a Model H2845 Pro-Stik® Cleaning Pad as shown in **Figure 39** in **Accessories** on **Page 34**.

To clean the belts:

1. DISCONNECT THE PLANER/SANDER FROM THE POWER SOURCE!
2. Open the upper left access door, loosen the cutterhead lock lever, move the cutterhead assembly all the way up—so the cutterhead will not cut the cleaning pad—then lock it in place.
3. Set your table to the thickness of the cleaning pad.
4. Connect power, then run the pad through the sander two or three times. DO NOT take too deep of a cut—the belt should barely touch the cleaning pad!
5. Reset the cutterhead to the 0mm position after you clean the sanding belt.

Cleaning Feed Belt

Vacuum or sweep dust off the feed belt with compressed air. Use a diluted solution of mild dish cleaning soap and water with a clean rag to remove wood resin from the belt. Do NOT use solvent cleaners or harsh chemicals.

Dust and Water Traps

Two collection traps on this planer/sander need to be emptied when they become half full. One water trap is attached to the bottom of the air regulator, and one dust trap is attached on the air diaphragm assembly. DO NOT allow the water trap and dust bowls to become full.

Dust Trap: To empty the dust trap bowl, TURN OFF AIR PRESSURE, allow air pressure to bleed out, then unscrew and empty the bowl (**Figure 45**).

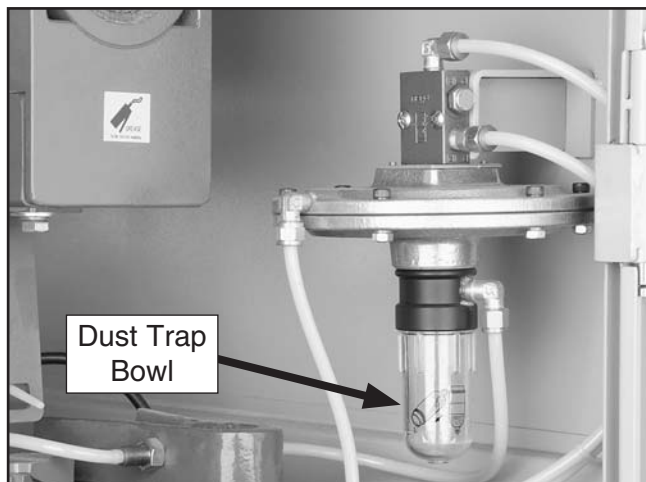

Figure 45. Diaphragm dust bowl.

Water Trap: With the system under air pressure, push the lower drain valve and empty the water trap (**Figure 46**). Also, replace the internal white moisture filters yearly.

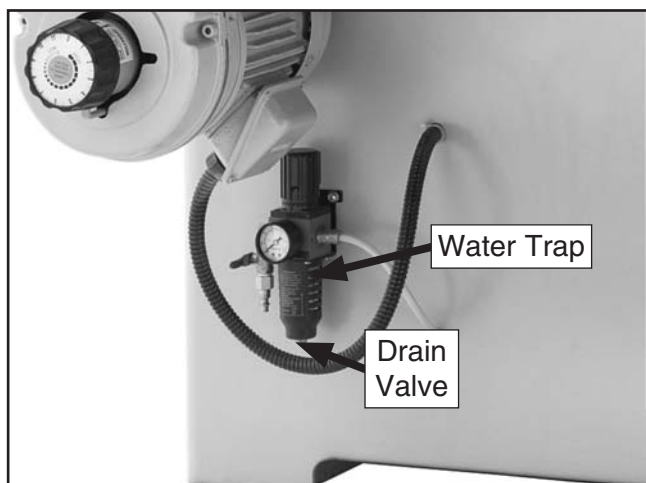

Figure 46. Water trap on the regulator.

Air System

The air system is durable and reliable; however, components do wear with age. If you suspect that an item in your air system may be having problems, see the **Air System Diagram** on **Page 60**.

- Adjust regulator to 75 PSI.
- Carefully inspect all air lines for cracks, chafing or hardening. Replace faulty hoses.
- Check the air connections for leaks. A small amount of soapy water in a questionable area will bubble if there is a leak.
- Make sure lines are not clogged. Remove a questionable line and blow through it as a test.

SECTION 7: SERVICE

Review the troubleshooting and procedures in this section to fix or adjust your machine if a problem develops. If you need replacement parts or you are unsure of your repair skills, then feel free to call our Technical Support at (570) 546-9663.

Troubleshooting

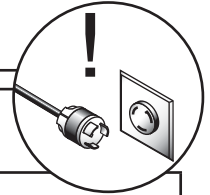

Motor & Electrical

Symptom	Possible Cause	Possible Solution
Machine does not start or a breaker trips.	<ol style="list-style-type: none"> 1. Front or rear stop push-button engaged. 2. Sanding belt position limit switch engaged/at fault. 3. Sanding belt tension limit switch engaged/at fault. 4. Electrical box or access door open/safety switch engaged. 5. Blown fuse. 6. Power supply switched OFF or at fault. 7. Motor connection wired wrong. 8. Thermal overload relay has tripped. 9. Wall circuit breaker tripped. 10. Contactor not energized/has poor contacts. 11. Wiring open/has high resistance. 12. Motor ON/OFF switch at fault. 13. Front or rear stop switch stuck/at fault. 14. Motor at fault. 15. Depth of cut too much. 	<ol style="list-style-type: none"> 1. Rotate button to reset/replace it. 2. Correct sanding belt oscillation (Page 44); replace faulty switch. 3. Turn on air pressure/tension sanding belt (Page 19); reposition/replace limit switch (Page 58). 4. Close door/replace safety switch. 5. Replace fuse/ensure no shorts. 6. Ensure power supply is on/has correct voltage. 7. Correct motor wiring connections. 8. Reset; adjust trip load dial if necessary; replace. 9. Ensure circuit size is correct/replace weak breaker. 10. Test all legs for power/replace if at fault. 11. Check/fix broken, disconnected, or corroded wires. 12. Replace switch. 13. Free stuck switch/replace. 14. Test/repair/replace. 15. Reduce depth of cut.
Machine stalls or is underpowered.	<ol style="list-style-type: none"> 1. Feed rate/cutting speed too fast for task. 2. Workpiece material is not suitable for this machine. 3. V-belt slipping. 4. Motor connection is wired incorrectly. 5. Motor bearings are at fault. 6. Contactor not getting energized or has poor contacts. 7. Motor has overheated. 8. Motor is at fault. 	<ol style="list-style-type: none"> 1. Decrease feed rate/cutting speed. 2. Only cut wood products; make sure moisture content is below 20% and there are no foreign materials in the workpiece. 3. Replace bad belt, align pulleys, and re-tension. 4. Correct motor wiring connections. 5. Test by rotating shaft; rotational grinding/loose shaft requires bearing replacement. 6. Test for power on all legs and contactor operation. Replace if faulty. 7. Clean off motor, let cool, and reduce workload. 8. Test/repair/replace.
Machine has vibration or noisy operation.	<ol style="list-style-type: none"> 1. Motor or component is loose. 2. Inserts are at fault. 3. V-belt worn or loose. 4. Pulley is loose. 5. Motor mount loose/broken. 6. Test by rotating shaft; rotational grinding/loose shaft requires bearing replacement. 7. Feed belt gear box at fault. 	<ol style="list-style-type: none"> 1. Inspect/replace stripped or damaged bolts/nuts, and re-tighten with thread locking fluid. 2. Rotate or replace inserts causing problem. 3. Inspect/replace belt with a new one (Page 52). 4. Realign/replace shaft, pulley, setscrew, & key. 5. Tighten/replace. 6. Motor bearings at fault. 7. Rebuild gear box for bad gear(s)/bearing(s).



Operation

Symptom	Possible Cause	Possible Solution
Machine slows when operating.	<ol style="list-style-type: none"> 1. Feed rate too high. 2. Depth of cut too great. 	<ol style="list-style-type: none"> 1. Feed workpiece slower (see Page 26). 2. Reduce depth of cut (see Page 30).
Loud, repetitious noise coming from machine.	<ol style="list-style-type: none"> 1. Pulley set screws or keys are missing or loose. 2. Motor fan is hitting the cover. 3. V-belt(s) is defective. 	<ol style="list-style-type: none"> 1. Inspect keys and set screws. Replace or tighten if necessary. 2. Tighten fan or shim cover. 3. Replace V-belt(s) (see Page 52).
Machine is loud, overheats or bogs down in the cut.	<ol style="list-style-type: none"> 1. Excessive depth of cut. 2. Dull or dirty sanding belt. 	<ol style="list-style-type: none"> 1. Decrease depth of cut (see Page 30). 2. Replace or clean sanding belt (Pages 37 & 27).
Rounded workpiece edges.	<ol style="list-style-type: none"> 1. Excessive depth of cut. 	<ol style="list-style-type: none"> 1. Reduce depth of cut (see Page 30).
Uneven thickness from left to right of board.	<ol style="list-style-type: none"> 1. Feed table not parallel to sanding roller and cutterhead. 2. Feed belt is worn. 	<ol style="list-style-type: none"> 1. Adjust the feed table (see Page 47). 2. Replace feed belt (see Page 55).
Workpiece slips on feed belt.	<ol style="list-style-type: none"> 1. Pressure rollers set too high. 2. Dirty feed belt. 3. Feed belt is worn. 4. Cutterhead set too low. 	<ol style="list-style-type: none"> 1. Lower pressure rollers (see Page 49). 2. Clean feed belt (see Page 37). 3. Replace feed belt (see Page 55). 4. Raise cutterhead at least even with sanding belt so pressure rollers move workpiece onto outfeed side of conveyor.
Grooves down length of workpiece.	<ol style="list-style-type: none"> 1. Pressure rollers are dirty or damaged. 	<ol style="list-style-type: none"> 1. Clean or repair pressure rollers.
Snakeshapedmarks on workpiece.	<ol style="list-style-type: none"> 1. Sanding belt damaged or dirty. 	<ol style="list-style-type: none"> 1. Clean or replace sanding belt (see Pages 37 & 27).
Lines across width of workpiece.	<ol style="list-style-type: none"> 1. Sanding belt seam is open or damaged. 	<ol style="list-style-type: none"> 1. Replace sanding belt (see Page 27).
Glossy spots or streaks on workpiece.	<ol style="list-style-type: none"> 1. Worn sanding belt. 2. Rear pressure roller too low. 	<ol style="list-style-type: none"> 1. Replace sanding belt (see Page 27). 2. Raise rear pressure roller (see Page 49 and warning in Pressure Roller section, Page 20).
Sanding belt clogs quickly.	<ol style="list-style-type: none"> 1. Sanding belt grit too small for particular job. 2. Excessive depth of cut. 3. Wood is too moist. 	<ol style="list-style-type: none"> 1. Replace with a coarser grit sanding belt. 2. Reduce depth of cut (see Page 30). 3. Allow wood to dry out.
Sanding belt does not tension correctly; rollers slip under belt.	<ol style="list-style-type: none"> 1. Low air pressure. 2. Air leaks in system. 	<ol style="list-style-type: none"> 1. Adjust air pressure to 75 PSI at primary regulator (see Page 18). 2. Inspect all hoses and connections for leaking air; use water on suspected area to detect bubbles.
Sanding belt runs off to one side, stopping the sander.	<ol style="list-style-type: none"> 1. Air eye fork clogged. 2. Airflow adjustment knob closed. 3. Belt tracking incorrect. 	<ol style="list-style-type: none"> 1. Clean the intake hole on the air eye fork. 2. Turn valve all the way out, then back in 3½" turns. 3. Adjust belt tracking (see Page 44).
Poor, non-aggressive sanding results.	<ol style="list-style-type: none"> 1. Worn sanding belt. 2. Sanding belt loaded with sawdust. 3. Planer cutterhead set too low. 	<ol style="list-style-type: none"> 1. Replace sanding belt with a new one (Page 27). 2. Clean sanding belt to unload sawdust (Page 37). 3. Raise cutterhead so sanding belt sands workpiece.



Symptom	Possible Cause	Possible Solution
Sanding belt will not start, but conveyor will.	<ol style="list-style-type: none"> 1. Sanding belt is not tensioned. 2. Limit switches engaged. 3. Emergency stop plate engaged. 4. No air pressure to sander. 5. Airflow adjustment valve closed. 	<ol style="list-style-type: none"> 1. Tension sanding belt (see Page 19). 2. Center sanding belt so it is not touching the limit switches (see Page 58). 3. Make sure emergency stop plate is released (Page 28). 4. Connect sander to compressed air system (Page 18). 5. Open airflow adjustment valve.
Feed belt not tracking in center.	<ol style="list-style-type: none"> 1. Feed belt moved out of adjustment. 	<ol style="list-style-type: none"> 1. Adjust feed adjustment bolts (see Page 57).
Feed belt slipping.	<ol style="list-style-type: none"> 1. Feed rollers have incorrect tension. 2. Feed rollers contaminated with dirt or dust. 	<ol style="list-style-type: none"> 1. Adjust feed rollers to place more tension on the feed belt (see Page 57). 2. Clean feed rollers.
Emergency brake stops slowly.	<ol style="list-style-type: none"> 1. Air pressure incorrect. 2. Air leak in system. 3. Brake rotor contaminated with oil. 4. Brake pads worn out. 	<ol style="list-style-type: none"> 1. Adjust air pressure to 75 PSI (see Page 18). 2. Find and fix air leaks. 3. Clean brake rotor with automotive brake parts cleaner. 4. Replace brake pads (see Page 43).
Grinding noise when braking.	<ol style="list-style-type: none"> 1. Brakes severely worn out. 	<ol style="list-style-type: none"> 1. Replace brake pads (Page 43), have rotor turned (possibly replaced).
Excessive snipe (gouge in the end of the board that is uneven with the rest of the cut). Note: <i>A small amount of snipe is inevitable if you set the cutterhead below 0 on the cutterhead height scale. The key is minimizing it as much as possible.</i>	<ol style="list-style-type: none"> 1. Cutterhead set even with or below sanding drum. 	<ol style="list-style-type: none"> 1. Raise cutterhead to 0mm mark on cutterhead height scale so sanding drum and pressure rollers are below cutterhead.
Raised lines, ridges or high spots on the workpiece.	<ol style="list-style-type: none"> 1. Nicked or chipped carbide inserts. 2. Carbide inserts not installed evenly. 	<ol style="list-style-type: none"> 1. Rotate or replace the affected carbide insert(s). 2. Make sure carbide inserts do not have debris under them; make sure inserts are torqued down evenly (Page 31).



Table Calibration

The digital thickness gauge is calibrated at the factory, but we recommend you verify its accuracy. This can be done by feeding a test board through the machine and measuring it in many locations on both sides along the length, then calibrating the digital display to match the average measured thickness of the workpiece.

Tools Needed	Qty
Test Board	1
Set of Calipers.....	1

Calibrating Digital Thickness Scale

1. Run the test board through the planer/sander three to four times to plane and sand it.
2. Turn the board over, and repeat **Step 2**.
3. Measure the thickness at various points around the board using a set of calipers.
4. Without moving the table height, enter the numerical measurement from **Step 3** into the digital key pad on the control panel.

Note: *The average thickness of the sanded wood should now be flashing on the digital read-out.*

5. Press and hold the Set key  until the display stops flashing. The machine is now correctly calibrated.

Table Limit Switches

The table limit switches prevent the table lift motor from driving the table into the sanding drum. Periodically check and adjust (if required) the table stop switches to protect the feed belt.

Tools Needed	Qty
Wrench or Socket 10mm	1

To check and adjust table limit switches:

1. Connect the planer/sander to power and air.
2. With the sanding belt motor **OFF**, use the up and down buttons to test the table.
3. Make sure the switches shut the table lift motor **OFF** when the table is at the minimum ($\frac{1}{8}$ ") and maximum distance (6") from the sanding drum.

—If the table lift motor does not shut **OFF** when the table reaches the minimum and maximum distances from the sanding drum, the limit switches need to be adjusted. Proceed to **Step 4**.

4. Push the down arrow key  and lower the table until there are six inches between the sanding drum and the feed belt table surface.
5. Loosen the mounting bolts for the table-down limit switch and slide the switch so the switch plunger depresses against the stop block and you hear the switch click (see **Figure 47**).

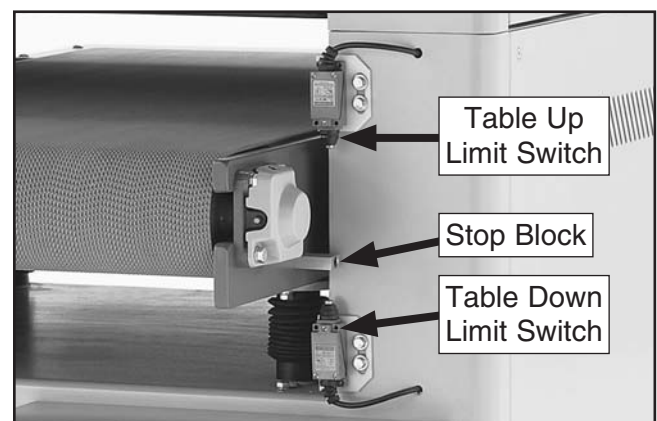



Figure 47. Table limit switches.



5. Re-tighten the mounting bolts.
6. Push the up arrow key  and raise the table until it is 1/8" below the sanding drum.
7. Loosen the limit switch bolts and move the switch so the plunger depresses against the stop block and you hear the switch click (see **Figure 47**), then tighten the bolts.
8. Repeat **Step 3** and readjust if necessary.

Brake Service

Eventually the brake pads will wear out. Checking and replacing these is a simple procedure that can be done in the shop, with the exception of having the rotor resurfaced on a lathe. The brake pads are located underneath the rotor as shown in **Figure 48**, which is attached to the motor arbor.

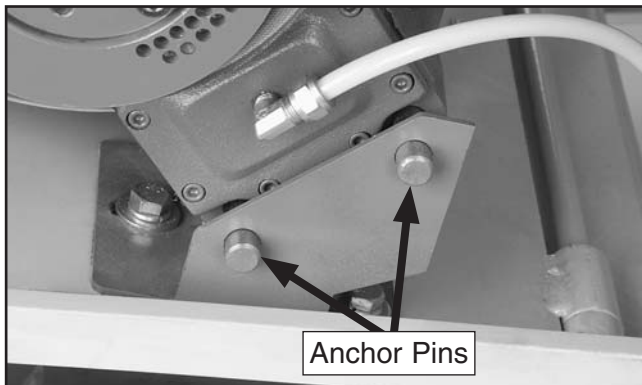

Figure 48. Disc brake assembly.

Tools Needed:	Qty
Open End Wrench 14mm.....	1
Snap Ring Pliers Small	1
Hex Wrench 6mm.....	1
Phillips Screwdriver #2	1
C-Clamp 8"	1

Checking Brake Pads

1. DISCONNECT THE PLANER/SANDER FROM THE POWER SOURCE AND REMOVE AIR PRESSURE COMPLETELY!
2. Unlock and open the lower right access door.
3. The brake pads consist of a metal plate with a composite pad. Using a fine ruler, measure the thickness of the composite pad only.

—If one of the pads is less than 1/8" (**Figure 49**) (approximately 3mm), replace both.

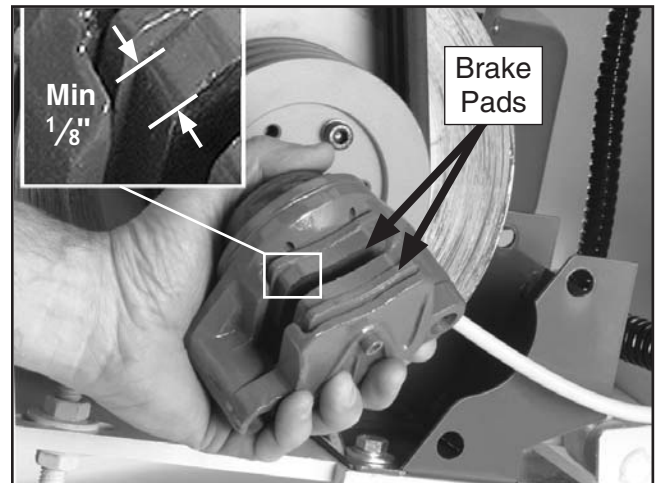

Figure 49. Example of brake caliper removed for access to brake pads.

Replacing Brake Pads

1. DISCONNECT THE PLANER/SANDER FROM THE POWER SOURCE AND DISCHARGE AIR PRESSURE COMPLETELY!
2. Remove the nuts and washers from the two anchor pins on each brake caliper (**Figure 48**).
3. Remove the anchor pins, springs, and air line from the caliper bracket. Now, remove the caliper.
4. Disassemble the brake caliper and remove the screws that secure the brake pads.
5. Remove the brake rotor and have it professionally resurfaced at an automotive machine shop if it has gouges in it. If visible cracks are present in the brake rotor, replace it with a new one. Remove oil and dirt from the rotor with automotive brake cleaner. Once clean, only handle the rotor with a dry rag and install exactly the reverse of removal. Use a C-clamp to compress the piston back into the caliper.
6. Install new brake pads, mount the caliper assembly by reversing **Steps 2-4**, and reconnect the air line.
7. Test the emergency stop system to make sure the brake works.



Belt Tracking Adjustments

The belt tracking adjustments have been performed at the factory and should require no further attention. However, we recommend that you verify the settings.

When correctly adjusted, the belt should take about the same amount of time to travel from one side of the upper roller to the other.

If you notice that the belt is tearing, is tracking toward one side more than the other, or contacting a limit switch and causing the emergency brake to stop the machine, belt tracking needs to be adjusted.

Tools Needed:	Qty
Wrench 9mm	1
Pencil or Pen	1

To check and adjust belt tracking:

1. Be sure the sanding belt is properly installed and the belt is tensioned, then **DISCONNECT THE PLANER/SANDER FROM THE POWER SOURCE AND REMOVE AIR PRESSURE!**
2. Open the upper left access door.
3. Visually check that the belt tracking adjustment knob (**Figure 50**) is centered, as shown in **Figure 51**.

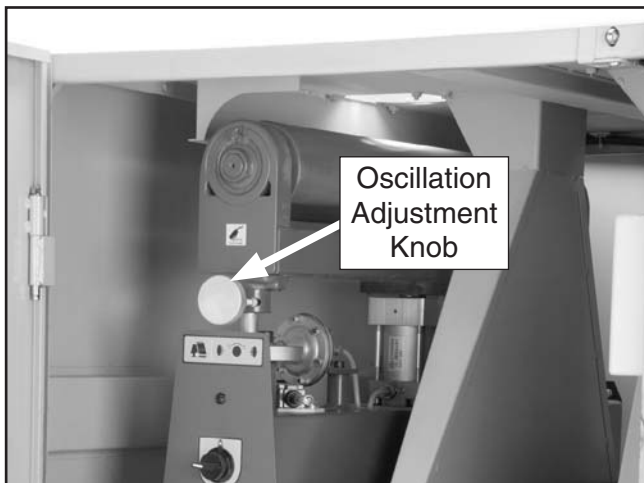

Figure 50. Oscillation adjustment knob.

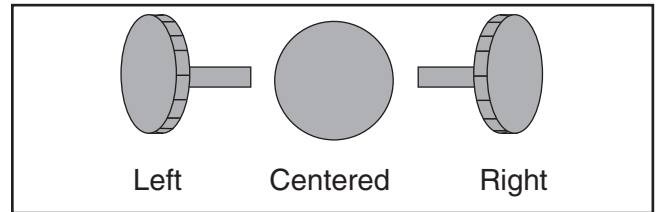

Figure 51. Belt tracking knob positions.

—If the knob is not centered, turn the knob counterclockwise to loosen it, move it to the center position—between 11 and 1 o'clock—as viewed straight on, then tighten the knob.

4. Open the upper right access door, loosen the lock nuts on the airflow adjustment knob and the oscillation speed control knob.

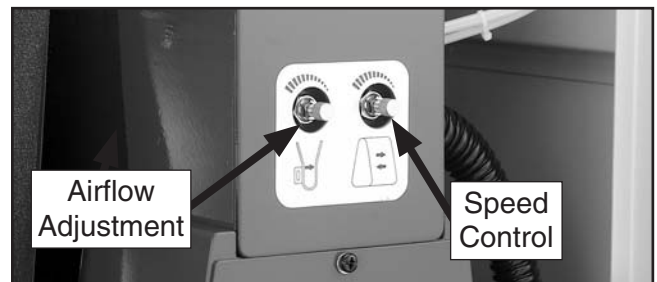

Figure 52. Airflow and oscillation speed control knob.

5. Turn both knobs counterclockwise all the way.
6. Make a reference mark using a pencil or pen at the 12:00 position, turn each knob clockwise $3\frac{1}{2}$ turns, then tighten the lock nuts.

This will reset the knobs to the factory setting and ensure there is an adequate amount of airflow through the air fork air jet so the upper roller pivots and the belt oscillates.

7. Connect the machine to power and air, and while pressing the upper left access door safety switch in, turn the sanding belt **ON**.
8. Observe the oscillation of the sanding belt. It should take the belt approximately the same amount of time to oscillate from one side to the other.

—If the belt oscillates to the left and right the same amount of time, no further adjustments are needed.



—If the belt oscillates to the left and right, but it takes longer to move toward one side or the other, the belt oscillation needs to be adjusted. Proceed to **Step 9**.

9. Loosen the oscillation adjustment knob.

—If the belt oscillates more slowly toward the left side of the upper roller (facing the front of the machine), turn the oscillation adjustment knob to the left, then tighten the knob. This will make the belt oscillate more quickly toward the left side.

—If the belt oscillates more slowly toward the right side of the upper roller (facing the front of the machine), turn the oscillation adjustment knob to the right, then tighten the knob. This will make the belt oscillate more quickly toward the right side.

10. Continue observing the oscillation of the sanding belt and adjust the oscillation adjustment knob as needed until it takes the belt approximately an equal amount of time to move back and forth.

11. If the belt still is not tracking correctly, clean out the dust trap (see **Page 38** for instructions).

12. Verify that the air diaphragm assembly switch is working by following the steps below.

A. With the motors **OFF**, place one finger in front of the air jet to block the air flow. Place another finger over the exhaust port on the diaphragm assembly (see **Figure 53**).

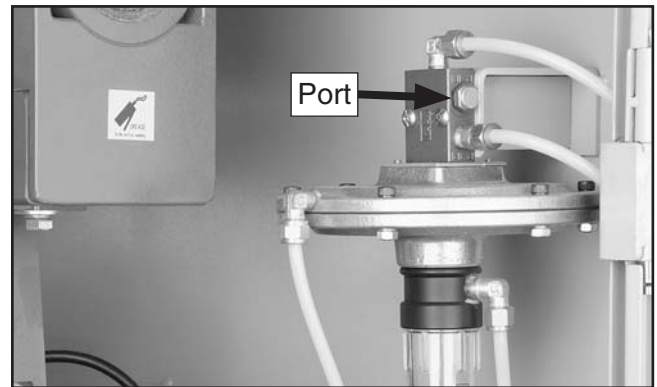

Figure 53. Upper bolt on diaphragm assembly.

B. When you remove your finger from the air jet stream you should feel a puff of air on the finger that is over the exhaust port and you should see the upper roller pivot. This indicates that the switch is working correctly.

—If you do not feel a puff or air, the switch may not be working and may need to be replaced.



Table Parallelism

The table has been adjusted at the factory and should require no further attention. However, we recommend verifying that it is parallel with the machine frame.

The four corners of the table can be independently adjusted up or down to achieve parallelism with the frame by adjusting the elevation screw flanges (Figure 54) or repositioning the pertinent table elevation screw sprocket on the chain (Figure 55).

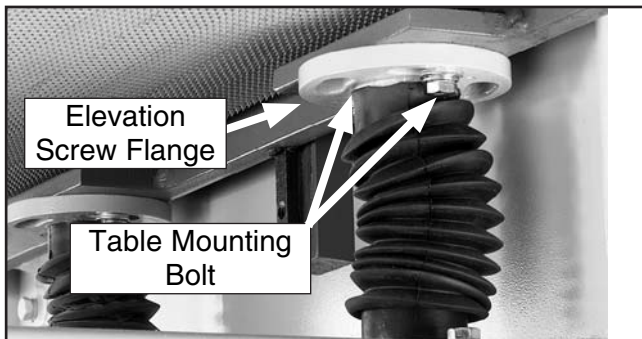

Figure 54. Table mounting bolts.

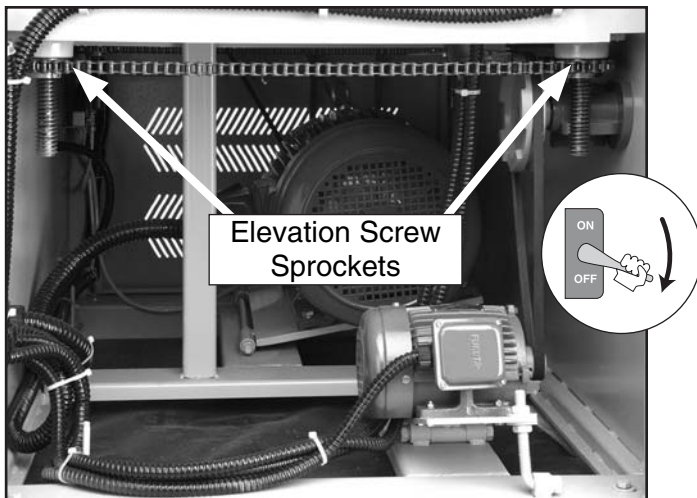

Figure 55. View of elevation screw sprockets.

Adjusting the table parallelism can take a fair amount of patience. **DO NOT adjust the table unless you are having trouble sanding your workpiece to a uniform thickness and have eliminated all other possible causes.**

If a table adjustment is needed, take precise notes on the positioning of the table elevation screws by marking them. This will allow the original setting to be restored if needed.

Tools Needed:	Qty
Standard Screwdriver	1
Phillips Screwdriver #2	1
Wrench 12mm	1
Wrench 14mm	1
Wrench 19mm	1
White Marker or Correction Fluid	Varies
Set of Feeler Gauges	1
Assistant	1
Straightedge	1

Table Parallelism Inspection

1. Open the upper left and right access doors, and use a vacuum cleaner and a shop rag to clean off the table and frame at each of the four corners so sawdust will not interfere with measurements in the following steps.
2. Raise the metal edge of the table so it is nearly level with the interior surface of the frame, then place a small straightedge at the front right corner of the frame so it overlaps the table edge, as shown in Figures 56–57.

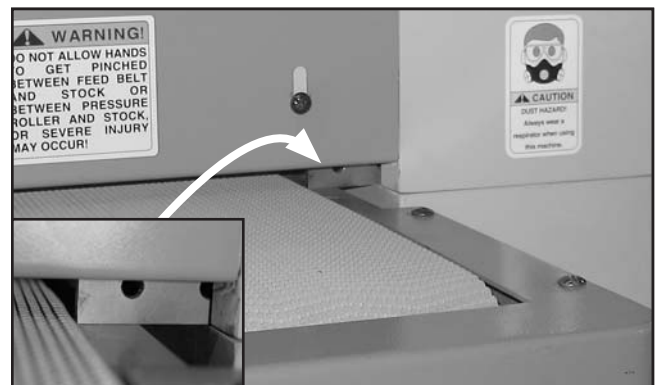

Figure 56. Straightedge flush with front right corner of frame and table.

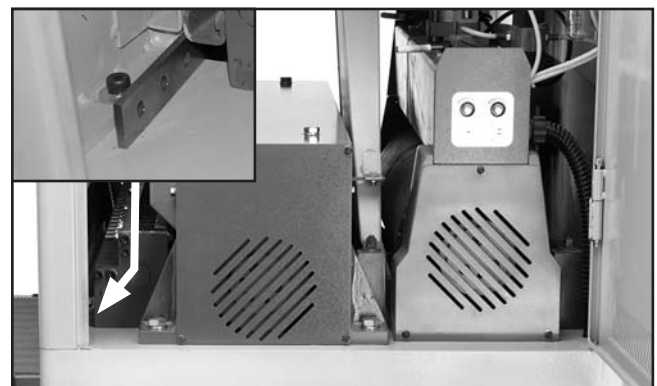

Figure 57. Right front table-frame height check location, straightedge on frame and table (inset).

- Adjust the table height using the handwheel, so the table and frame are flush with the bottom of the straightedge, as shown in **Figure 58**.

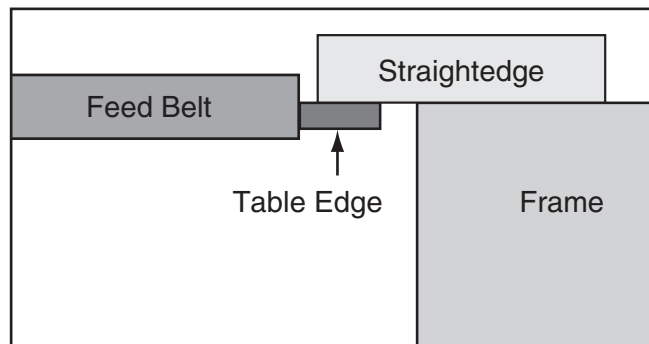

Figure 58. Bottom edge of frame and table edge flush.

- Without changing the table height, check the frame and table height at the other three locations, as shown in **Figures 59 & 60**, in a similar manner as you did in **Step 3**.

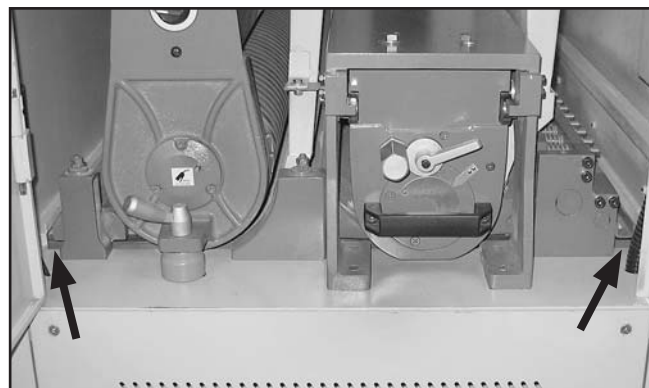

Figure 59. Left table-frame height check locations.



Figure 60. Right rear table-frame height check location.

—If the table and frame are even at all the locations the table is parallel with the frame. No further adjustments need to be made.

—If the table is higher or lower than the frame by more than 0.003" at any of these locations, proceed to **Adjusting Table Parallelism**.

Adjusting Table Parallelism

- DISCONNECT THE PLANER/SANDER FROM THE POWER SOURCE!
- Locate the elevation screw flange at the corner that needs to be adjusted.
- Loosen the table mounting bolts on the flange (see **Figure 61**), then rotate the flange a small amount to the right to raise or to the left to lower that corner of the table so it is within 0.003" of the frame.

Tip: It may help to rotate an elevation screw flange with vise grips if it is difficult to move.

Each screw flange can be adjusted up to 0.015" between the right and left sides.

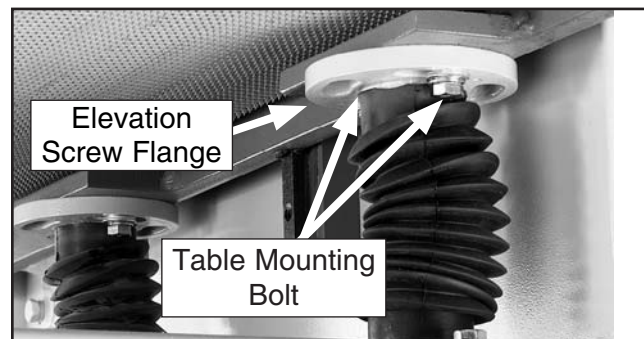

Figure 61. Table mounting bolts.

- Tighten the table mounting bolts.
- Repeat **Steps 1-3** in a similar manner to adjust additional table corners to within 0.003" of the frame.

—If the table and frame are even at all the corners, no more adjustments need to be made.

—If any of the corners are still higher or lower than the frame by more than 0.003", you will need to adjust the elevation screw sprocket at that specific corner of the table. Each sprocket tooth represents 0.011" of vertical movement.

6. Remove/open the lower access panels/doors.
7. Mark the location of one tooth in the sprocket that you are adjusting.
8. Loosen the chain tensioner sprocket adjustment nut on the sprocket wheel shaft (**Figure 62**) and loosen the jam nut on the sprocket adjustment rod.

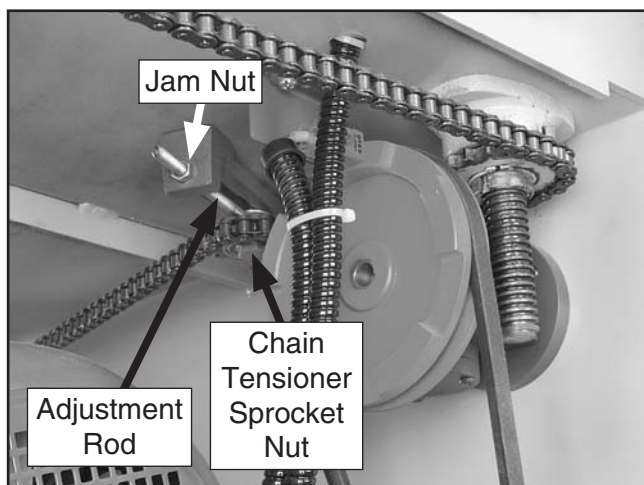

Figure 62. Table chain tensioner components.

9. Push the sprocket adjustment rod toward the frame (or away from you) to loosen the chain tension.

10. Move the chain away from only the sprocket you want to adjust so only that sprocket can be turned independent of the chain.
11. Carefully turn the sprocket counterclockwise to raise the table just enough to position the next tooth at the marked location, then fit the chain around the sprocket again.
12. Move the sprocket adjustment rod toward you, tighten the jam nut, then tighten the sprocket nut. The chain should be moderately tight.
13. Fine tune the height of the table corners that were higher or lower than the machine frame by adjusting the elevation screw flanges in a similar manner as you did in **Step 3** to bring each of the table corners within 0.003" of the frame.
14. Close all access doors.

Pressure Rollers

The pressure rollers have been adjusted at the factory and should require no further attention.

Ideally the pressure rollers should be positioned slightly lower than the sanding drum. However, we recommend verifying this setting.

Factory Settings

Infeed & Outfeed Pressure Roller Setting Below Sanding Drum 0.035"

Tools Needed

	Qty
6' Long 2x4 Cut in Half.....	1
Wrench 14mm	1

To adjust the pressure rollers:

1. Plane a 6' long 2x4 to a uniform thickness and cut it in half. Place one board along the length of the feed belt on the right-hand side and place the other board on the left-hand side, as shown in **Figure 63**.



Figure 63. 2x4s placed on feed belt under sanding drum.

2. DISCONNECT THE PLANER/SANDER FROM THE POWER SOURCE!
3. Raise the cutterhead up to the 2mm mark so it does not interfere with your adjustments in the following steps.
4. Open the upper left access door and remove the sanding belt.
5. Move the sanding drum by hand and manually raise the table until you hear the rubber drum just contact the surface of the wood. DO NOT continue to raise the table beyond this point.

6. Connect the machine to the power source and make note of the reading on the digital display. Then manually lower the table 0.035". This is how much lower than the sanding drum the infeed pressure roller and outfeed pressure rollers should be.
7. DISCONNECT THE PLANER/SANDER FROM THE POWER SOURCE!
8. Loosen the infeed pressure roller lock nuts (**Figure 64**) on the infeed pressure roller. Turn the adjustment studs (**Figure 64**) to lower the infeed pressure roller until it just touches the boards.

Note: DO NOT continue to lower the roller beyond this point.

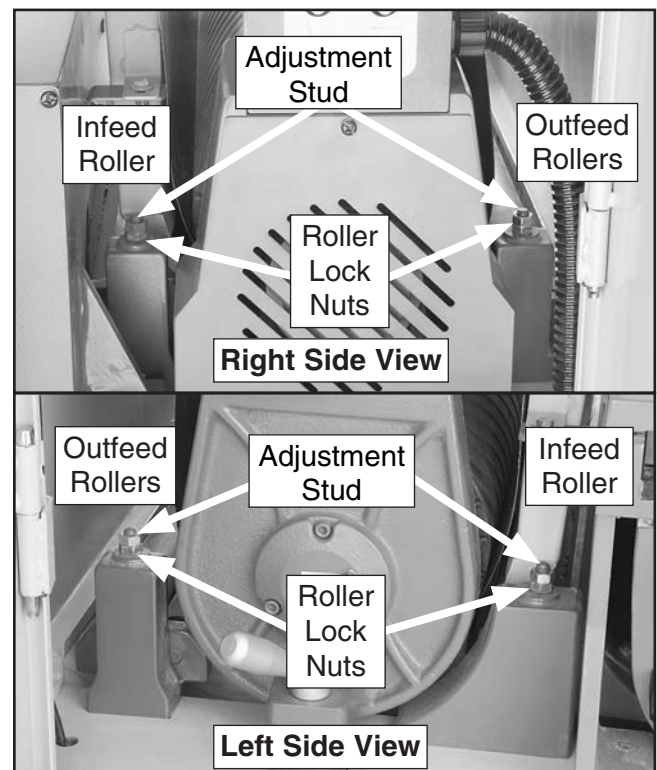

Figure 64. Infeed pressure roller adjustment locations.

9. Tighten the roller lock nuts.
10. Repeat **Steps 7-8** in a similar manner to lower the outfeed pressure rollers until they just touch the boards, then tighten the roller lock nuts and recheck your settings.



Note: Variables such as feed rate, depth of the cut, and the type of sanding belt can play a big part in determining the proper amount of downward pressure exerted by the rollers. Some experimentation may be necessary to achieve the desired results. However, under no circumstances should the pressure rollers be set even with, or higher than, the sanding roller.

11. Lower the table and remove the 2x4s.
12. Lower the cutterhead back to 0mm on the height scale and lock it in place, then re-install the sanding belt.

Adjusting Depth of Cut Safety Bar

When properly adjusted, the depth of cut safety bar prevents the operator from exceeding the maximum depth of cut.

The position of this safety bar (**Figure 65**) was factory set approximately $\frac{1}{8}$ " above the lowest point of the cutterhead. We recommend that this safety bar remain at this setting.

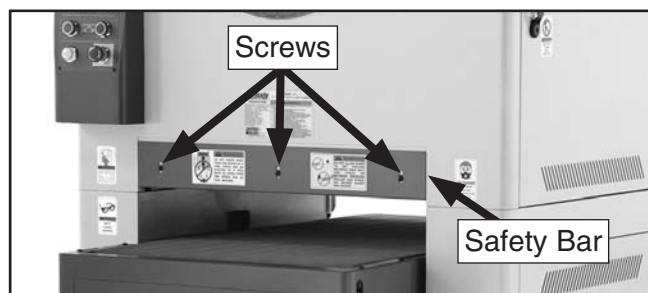

Figure 65. Depth of cut safety bar.

To adjust the depth of cut safety bar:

1. Plane and sand a 24" wide board through the machine so it makes a full cut.
2. Set the board under the front of the machine, then raise the table $\frac{1}{8}$ ".
3. Loosen the screws on the safety bar enough so the bar contacts the top of the workpiece, then tighten the screws.

V-Belt Tension

The cutterhead, idler, sanding drum and table elevation V-belts must be tensioned properly for best performance. Always replace each of these V-belts as a matched set.

Note: The belts on the main motor must be tensioned correctly. Loose belts will not allow the machine to stop immediately if the emergency push panel is pushed.

The main motor uses a set of four matching belts, the sanding drum pulleys use two matching belts, and the table elevation motor uses one belt.

Tools Needed	Qty
Wrench 14mm	1
Wrench 19mm	1
Wrench or Socket 26mm.....	1

Adjusting Table Elevation Motor V-Belt

1. DISCONNECT THE PLANER/SANDER FROM THE POWER SOURCE!
2. Loosen the lock nut (see **Figure 66**).

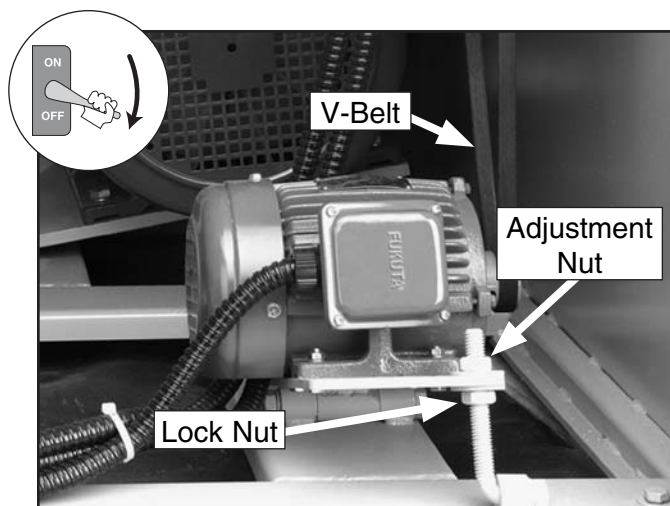

Figure 66. Table elevation motor V-belt.



3. Turn the adjustment nut up or down until the V-belts deflect $\frac{1}{2}$ - $\frac{3}{4}$ " off of center when pushed hard with your finger, as shown in **Figure 67**.

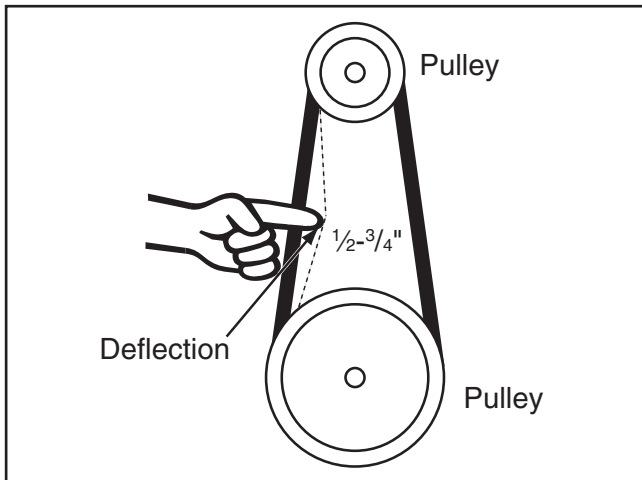

Figure 67. Correct V-belt deflection.

4. Retighten the lock nut.

Adjusting Cutterhead & Idler V-Belts

1. DISCONNECT THE PLANER/SANDER FROM THE POWER SOURCE!
2. Loosen the lock nuts on the tension bolt (see **Figure 68**).

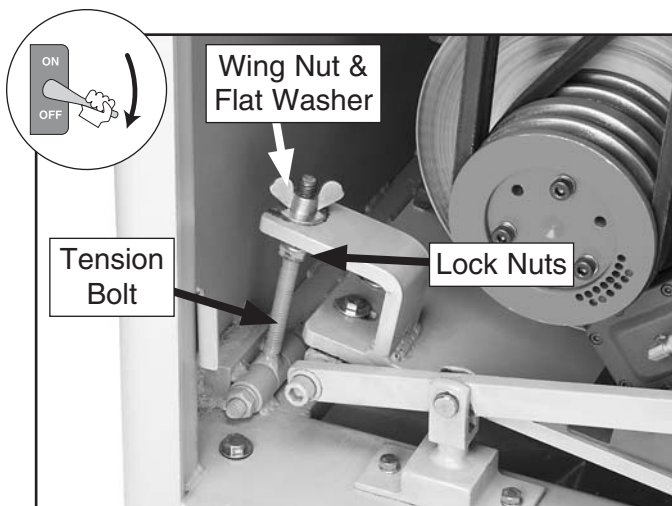

Figure 68 Tension bolt wing nut .

3. Turn the wing nut until the V-belts deflect $\frac{1}{2}$ - $\frac{3}{4}$ " off of center when pushed with your finger, as shown in **Figure 67**.

4. Retighten the lock nuts.

Adjusting Sanding Drum V-Belts

1. DISCONNECT THE PLANER/SANDER FROM THE POWER SOURCE!
2. Loosen the lock nuts on the idler pulley adjustment bracket (see **Figure 69**).

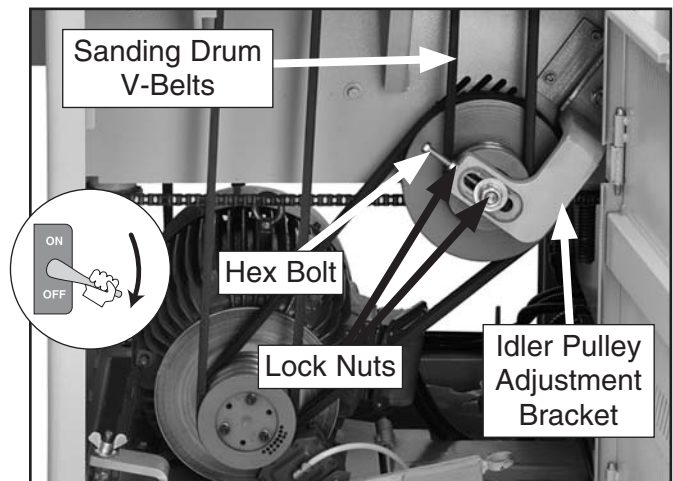

Figure 69. Sanding drum V-belt adjustment locations.

3. Turn the long hex bolt to adjust the V-belt tension until the belts deflect $\frac{1}{2}$ - $\frac{3}{4}$ " off of center when pushed with your finger, as shown in **Figure 67**.
4. Retighten the lock nuts.

Changing V-Belts

Check the V-belts periodically to check for signs of glazing, cracking or fraying. If any of these conditions are present, replace each of the V-belts as a matched set.

Tools Needed:	Qty
Wrench 14mm	1
Wrench 19mm	1
Wrench or Socket 26mm.....	1
Phillips Screwdriver #2	1
3' Long 2x4.....	1
3' Long 1x4.....	1
Assistant (Optional)	1

Cutterhead V-Belts

1. DISCONNECT THE PLANER/SANDER FROM THE POWER SOURCE!
2. Open the upper and lower right access doors.
3. Loosen the wing nut on the tension bolt (see **Figure 68** on **Page 51**), move the wing nut and bolt out of the way, press down on the foot pedal to detension the V-belts, then secure it with the safety latch.
4. Roll the cutterhead V-belts off of the motor and cutterhead pulleys.
5. Install a new matching set of cutterhead V-belts.
6. Repeat **Step 3** in reverse order to retension the V-belts.
7. The belts are properly tensioned when they will not move more than $\frac{1}{2}$ - $\frac{3}{4}$ " when pushed hard with your finger, as shown in **Figure 67** on **Page 51**.
8. Close the right access doors.

Idler V-Belts

1. DISCONNECT THE PLANER/SANDER FROM THE POWER SOURCE!
2. Repeat **Steps 2–4** in **Cutterhead V-Belts**.
3. As an additional precaution, place a 2x4 and a 1x4 under the motor assembly, as shown in **Figure 70**. This will reduce the risk of serious personal injury by ensuring the motor assembly and foot pedal remain stationary during the following steps.

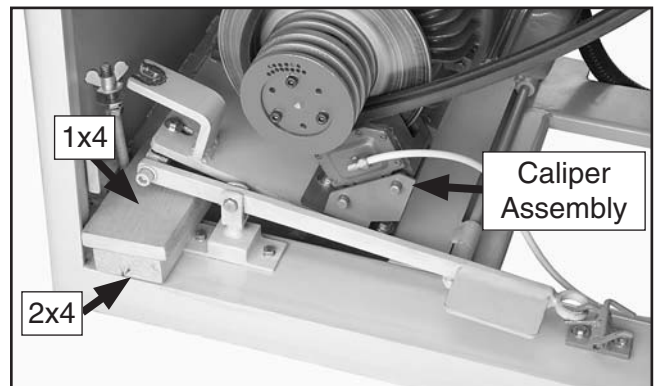

Figure 70. 2x4 positioned between frame and motor.

CAUTION

If you accidentally bump the safety latch while the foot pedal is locked—without 2x4s and shims in place, the motor assembly could suddenly drop and the foot pedal could become unlatched and fly up, causing serious injury to your fingers or hands.

4. Remove the sanding belt safety cover.
5. Mark the left edge of the caliper assembly (see **Figure 71**) with a pencil to make it easier to return the assembly to the correct position.



Figure 71. Marking caliper assembly location.

- Loosen and remove the two hex bolts and washers that secure the caliper assembly (**Figure 72**), then move it out of the way.

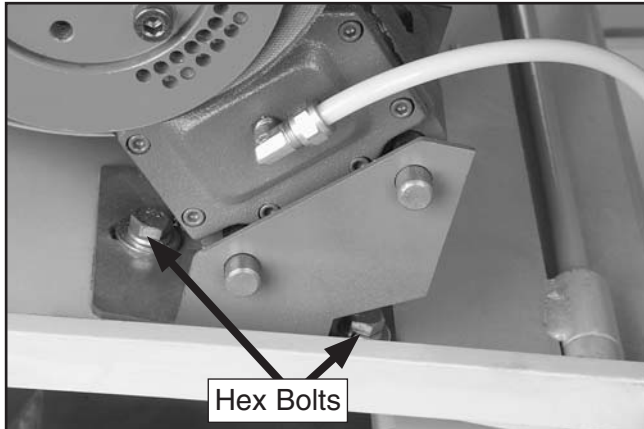

Figure 72. Nuts securing caliper.

- Roll the idler V-belts off of the motor pulley.
- Loosen the lock nuts on the idler pulley adjustment bracket (see **Figure 69** on **Page 51**).
- Remove the hex nut that secures the idler wheel adjustment bracket to the frame (**Figure 73**).

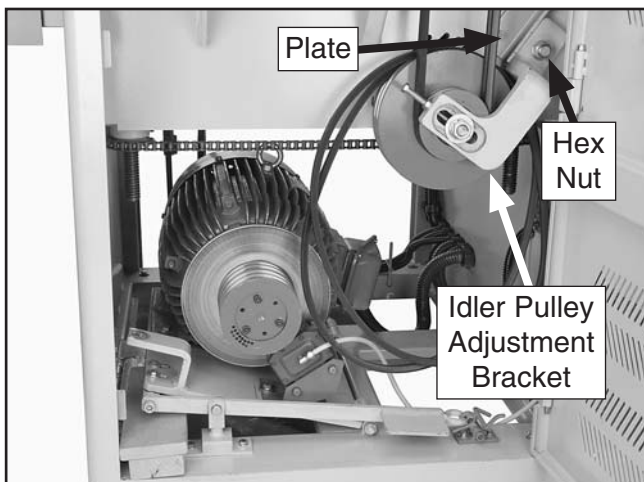

Figure 73. Location of hex nut securing idler adjustment bracket to frame.

- Move the idler pulley adjustment bracket off of the rear stud, then roll the idler V-belts off of the back of the pulley. Jostle the bracket a little if it is difficult to remove.

- Roll a new set of V-belts onto the idler pulley and the motor pulley.
- Reverse **Steps 2-10** to re-install the idler wheel adjustment bracket, caliper assembly, and the cutterhead V-belts.
- Tension all the V-belts: The belts are properly tensioned when they will not move more than $\frac{3}{4}$ " in the center when pushed with your finger with moderate pressure, as shown in **Figure 67** on **Page 51**.

Sanding Drum V-Belts

- DISCONNECT THE PLANER/SANDER FROM THE POWER SOURCE!
- Follow the instructions for removing the cutterhead and idler V-belts (**Steps 1-10, Idler V-belts** on **Page 52**).
- Lift the idler pulley adjustment bracket off of the sanding drum V-belts, set it aside, then remove the sanding drum V-belts.

!WARNING

Have an assistant help you during the following step. The idler pulley adjustment bracket is heavy. Serious personal injury could occur if you drop it on your body!

- Place a new matching pair of sanding drum V-belts onto the idler roller and also roll on the idler V-belts.
- While holding the idler roller bracket up, have an assistant install the sanding drum V-belts onto the sanding drum pulley, then push the idler pulley bracket back onto the rear stud.
- Fasten the idler pulley bracket with the hex bolt removed earlier, making sure the bracket is flush with the plate shown in **Figure 73**.

7. Roll the idler V-belts onto the motor pulley, then roll the cutterhead V-belts onto the motor and cutterhead pulleys.
8. Remove the 2x4 and 1x4, then unlatch and raise the foot pedal to tension the V-belts.
9. Adjust the sanding belt tension with the long hex bolt. The belts are properly tensioned when they will not move more than $\frac{3}{4}$ " in the center when pushed with your finger with moderate force, as shown in **Figure 67** on **Page 51**.
10. Tighten the idler pulley bracket lock nuts.

⚠️ WARNING

Make sure the foot pedal is unlatched during the next step, to prevent the motor assembly from suddenly dropping while you work on the caliper assembly. Your fingers or hands could be seriously injured if the foot pedal is accidentally unlocked.

11. Re-install the caliper assembly with the hex bolts and washers removed earlier, making sure the left side of the assembly aligns with the pencil mark you made in **Step 5** on **Page 52**.
12. Re-install and retighten the tension handle.
13. Re-install the sanding belt safety cover and close the access panels.
14. Test the emergency brake operation to make sure it works properly.

Table Elevation Motor V-Belts

1. **DISCONNECT THE PLANER/SANDER FROM THE POWER SOURCE!**
2. Remove the lower left access panel.
3. Loosen the lock nut shown in **Figure 66** on **Page 50** enough to move the motor plate up and remove the table elevation V-belt from the motor pulley.
4. Mark the left side of the handwheel indicator sensor plate (see **Figure 74**).

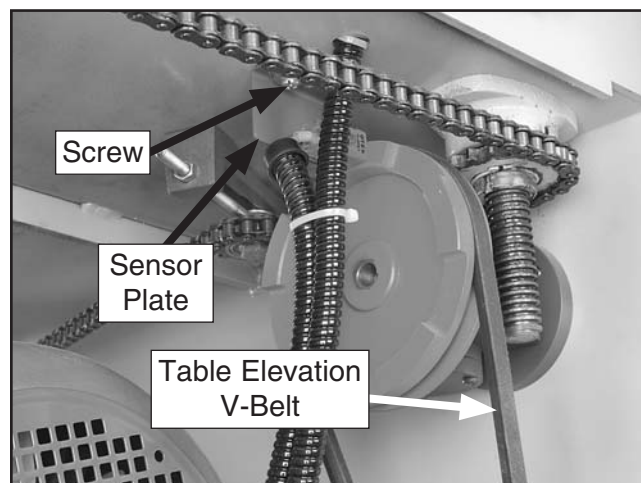

Figure 74. Handwheel indicator sensor plate.

5. Loosen the screw on the plate, move the sensor to the left, then remove the V-belt.
6. Install a new V-belt on the pulleys.
7. Return the plate to its original location, using the mark from **Step 4**, then tighten the screw.
8. Tighten the lock nut so the V-belt deflects $\frac{3}{4}$ " off of center when pushed with moderate pressure, as shown in **Figure 67** on **Page 51**.

Feed Belt Replacement

Replace the feed belt if it becomes damaged or you are not able to adjust belt tracking due to wear, using the instructions on **Page 57**.

Tools Needed:

Qty

Make sure that you have a lifting device or another person to help in table removal.

Hex Wrench 10mm	1
Combination Wrench 19mm	1
Combination Wrench 12mm	1
Combination Wrench 14mm	1
Phillips Screwdriver #2	1
8' 2x4s	2
Permanent Marker	1
Lifting Assistants	As Needed

To remove the feed belt, use Figure 76 and match the number with the steps below:

1. Adjust the table so the feed belt is approximately two-inches away from the sanding roller, then **DISCONNECT THE PLANER/SANDER FROM THE POWER SOURCE!**
2. Remove the gear box mounting bracket, and with an assistant's help, slide the motor and gear box from the roller shaft and lower it to the floor. **Note: Do not loosen the two vibration dampener washers shown in Figure 76.**
3. Remove the two table height limit switches.
4. Remove both lower access panels/doors.
5. Remove the left and right table guides.
6. Using a permanent marker, mark all four leadscrew flange positions (**Figure 75**), and remove all bolts from the flanges. Try not to turn the flanges during the following steps.

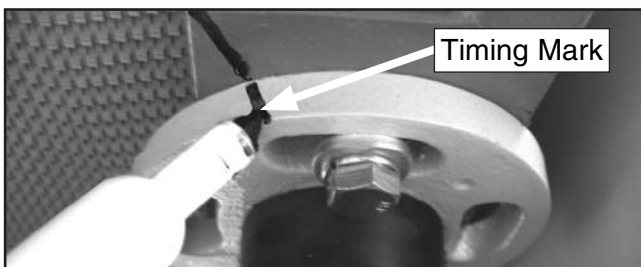

Figure 75. Marking leadscrew for reassembly.

7. Insert two 2x4 x 8' wooden studs under the table to support the table, and then (with help) lift the table slightly and move it out of the rear of the machine.
8. Disconnect the limit switch, remove all mounting screws, and remove the emergency stop plate assembly.
9. Turn both tracking adjustment bolts counter-clockwise five turns, remove one roller support, and slide the drum out of the table assembly.
10. Remove the old feed belt, inspect rollers, bearings, and table for wear and replace as required.
11. Install the new feed belt. **Note: The belt is non-directional.**
12. Install the front roller, the roller support, and turn both tracking adjustment bolts clockwise equally so the feed belt becomes taught and does not hang loose. **DO NOT OVERTIGHTEN** the belt.
13. With a helper, install the table from the rear in a similar fashion as it was removed.
14. Install the table guides and the left and right lower access panels/doors.
15. Align the leadscrew flanges with the marks made in **Step 6**, and install the hex bolts.
16. Install the table height limit switches (refer to **Page 42**)
17. With a helper, install the gear box, vibration dampener washers, and mounting bracket.
18. Install the emergency stop plate assembly and the limit switch.
19. Start the conveyor motor and turn the conveyor tracking bolts as required until the feed belt tracks straight without loading up on one side of the table.



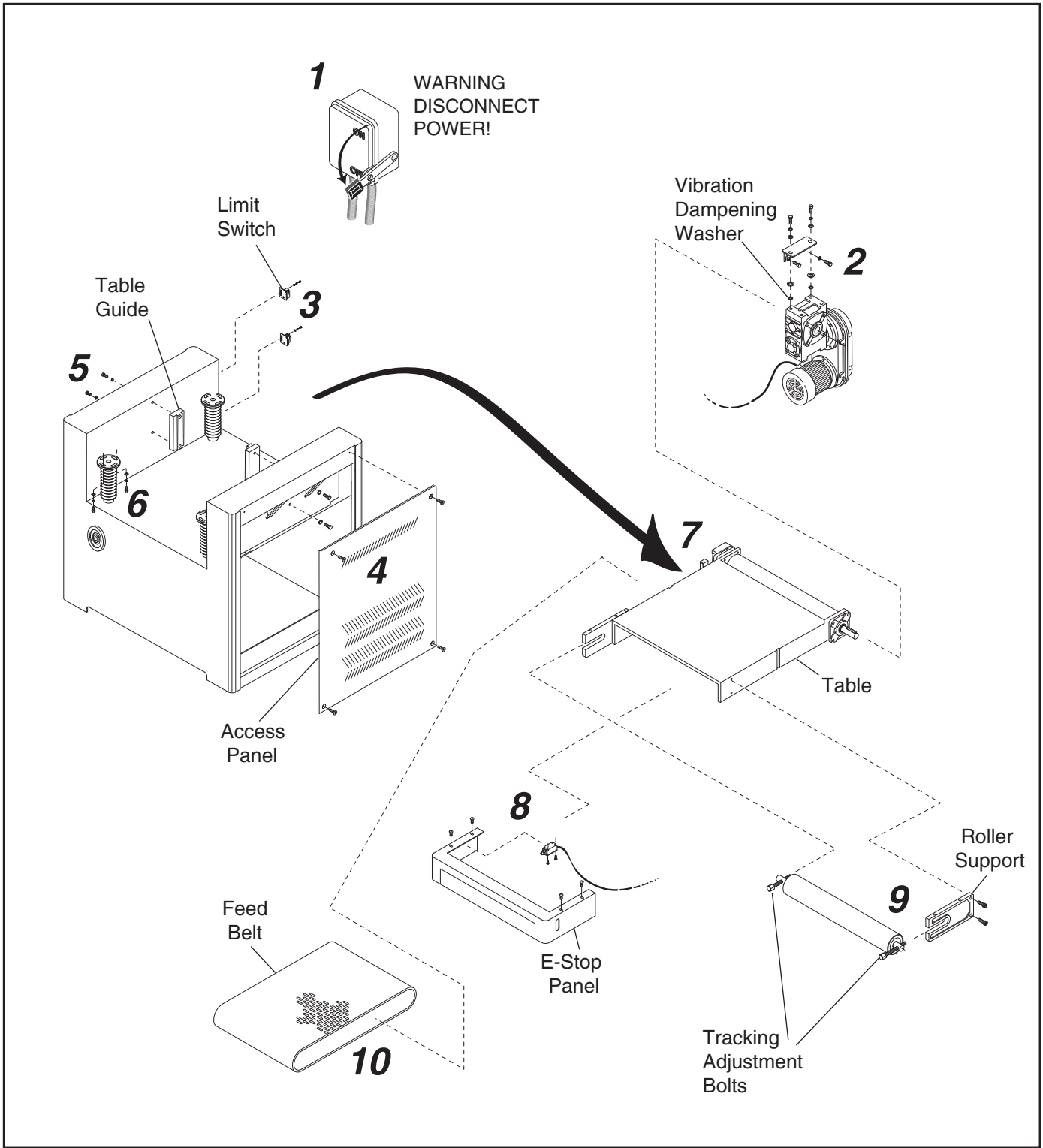

Figure 76. Feed belt removal sequence.



Feed Belt Tension

The feed belt tension has been adjusted at the factory and should require no further attention. However, adjust the feed belt tension if you notice that your feed belt is slipping or is tracking off center.

Tools Needed:	Qty
Wrench or Socket 10mm.....	1
Phillips Screwdriver #2.....	1

To adjust the feed belt tension:

1. DISCONNECT THE PLANER/SANDER FROM THE POWER SOURCE!

DO NOT REMOVE THE SAFETY GUARD DURING THE FOLLOWING STEPS!

2. Find the adjustment ports in the safety guard (**Figure 77**) at the front end of the feed table.
3. Turn both left and right adjustment bolts (**Figure 77**) clockwise equally to increase tension.

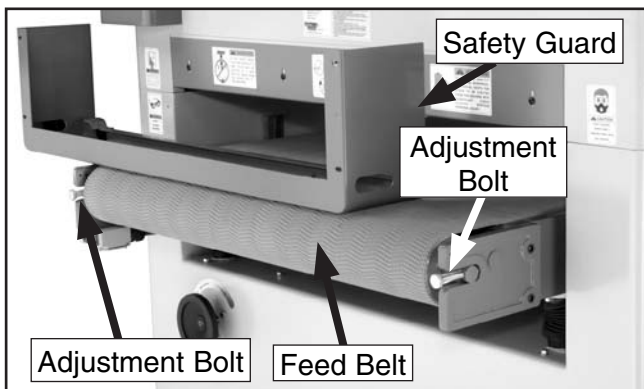

Figure 77. Feed belt tension adjustment bolts.
Note: Safety guard removed only for clarity.

4. When tensioned properly you should not be able to lift the feed belt off of the table surface or slide it back and forth.

!WARNING

DO NOT sand boards with the guard removed. Failure to follow this warning could result in serious personal injury.

Feed Belt Tracking

Tools Needed:	Qty
Wrench or Socket 19mm.....	1

NOTICE

Adjust the feed belt tension before adjusting the feed belt tracking.

To adjust the feed belt tracking:

1. Turn the feed belt **ON**.
2. If the feed belt is tracking to the **right** side of the table, turn the **right** adjustment bolt (**Figure 77**) clockwise.
3. If the feed belt is tracking to the **left** side of the table, turn the **left** adjustment bolt clockwise.

Note: The edge of the feed belt should just touch the guide wheels as shown in **Figure 78**.

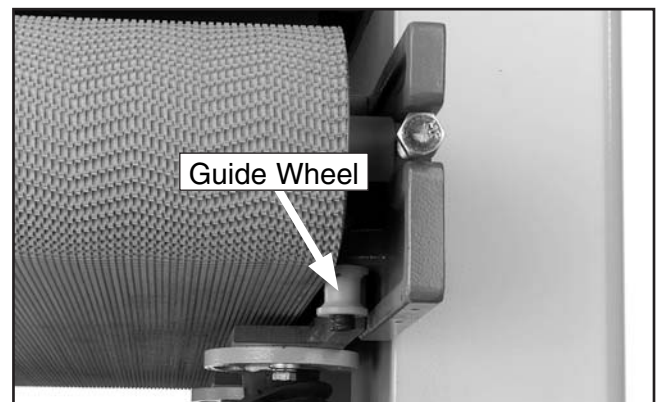

Figure 78. Guide wheels.

Note: Safety guard removed only for clarity.

4. Run the feed belt for 3-5 minutes and recheck the tracking.
5. Repeat **Steps 2-4** until the feed belt tracking is satisfactory.



Sanding Belt Limit Switches

Tools Needed: Qty
Wrench or Socket 12mm..... 1

Sanding belt tracking limit switches are placed on both sides of the belt to act as emergency machine stops if the belt travels too far to one side or the other during oscillation (see **Figure 79**).

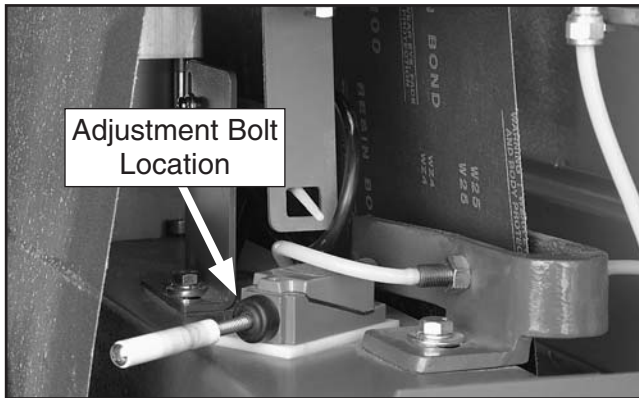

Figure 79. Tracking limit switch adjustment bolt (right side shown).

To adjust the belt tracking limit switches:

1. DISCONNECT THE PLANER/SANDER FROM THE POWER SOURCE!
2. Make sure the sanding belt tracking and oscillation is adjusted properly (see **Page 44**).
3. Release the belt tension, center the sanding belt on the top roller, then re-tension the belt.
4. Measure the distance from the edge of the sanding belt to the ceramic rod protruding from the switch.
5. Loosen the adjustment bolt shown in **Figure 79**, and move the switch so the belt and the ceramic rod are approximately 1/2" apart.
6. Tighten the bolt and repeat the adjustment with the other side if necessary.
7. Start the machine and make sure it is working properly.

Sanding Belt Tension Limit Switch

The belt tension safety switch shuts the sanding motor **OFF** if the belt breaks or has no tension when the lock flange pushes the belt tension safety switch lever (see **Figure 80**).

Tools Needed: Qty
Wrench or Socket 12mm..... 1
Phillips Screwdriver #2 1

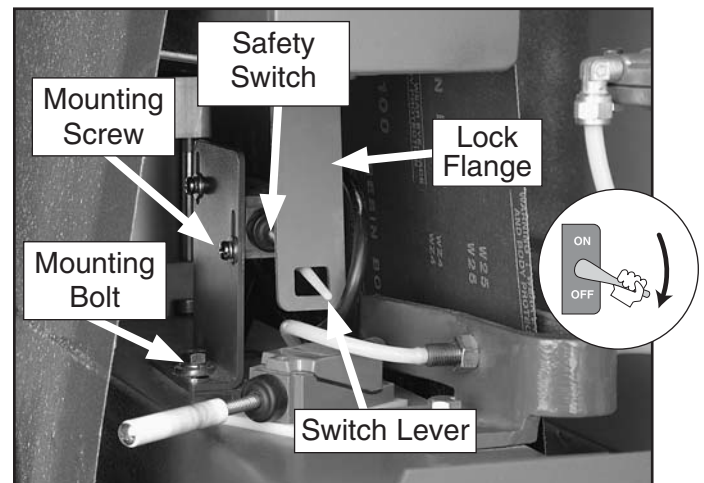

Figure 80. Belt tension safety switch.

To adjust the belt tension safety switch:

1. DISCONNECT THE PLANER/SANDER FROM THE POWER SOURCE!
2. Apply normal system air pressure of 75 PSI, and tension the belt.
3. Open the right upper right access door.
4. Loosen the mounting screw and hex bolt, and position the switch so the lever is in the center of the lock flange hole.
5. Re-tighten the screw and hex bolt, then test the switch operation.



Chip Breaker and Tension

Tools Needed:	Qty
Wrench or Socket 14mm	1

The chip breaker spring tension is factory set so that the hex bolts shown in **Figure 81** protrude $\frac{1}{2}$ " from the lock nuts across the length of the chip breaker assembly.

If you ever have to replace components in the planer/sander that change the chip breaker setting, use the factory setting to reset it for best performance.

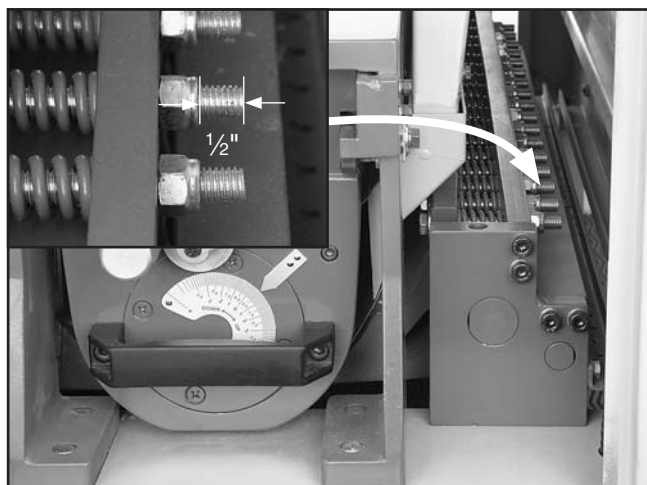

Figure 81. Chip breaker spring tension setting.

Anti-Kickback Fingers

The Model G0677 provides an anti-kickback system as a safety feature. The anti-kickback fingers hang from a rod suspended across the cutterhead casting.

Regularly check the fingers (**Figure 82**) to ensure that they swing freely and easily. If the fingers do not swing freely and easily, clean them with a wood resin solvent.



Figure 82. Anti-kickback fingers.

!WARNING

Proper operation of the anti-kickback fingers is essential for the safe operation of this machine. Failure to ensure that they are working properly could result in serious operator injury.

Do not apply oil or other lubricants to the anti-kickback fingers. Oil or grease will attract dust, restricting the free movement of the fingers.



Air System Diagram

- A. Shop Compressor
- B. Air Pressure Regulator
- C. Emergency Brake Solenoid
- D. Emergency Brake
- E. Air Distribution Manifold
- F. Airflow Adjustment Knob
- G. Speed Control Adjustment Knob (Oscillation Timing)
- H. Oscillation Controller Air Fork
- I. Oscillation Timing Piston and Diaphragm Assy.
- J. Oscillation Speed Control Piston
- K. Belt Tension Control Piston
- L. Belt Tension Control Switch
- M. Front Stop Button Switch
- N. Emergency Stop Plate Switch
- O. Left Belt Limit Switch
- P. Right Belt Limit Switch
- Q. Belt Tension Limit Switch
- R. Emergency Brake Contactor
- S. Rear Stop Button Switch

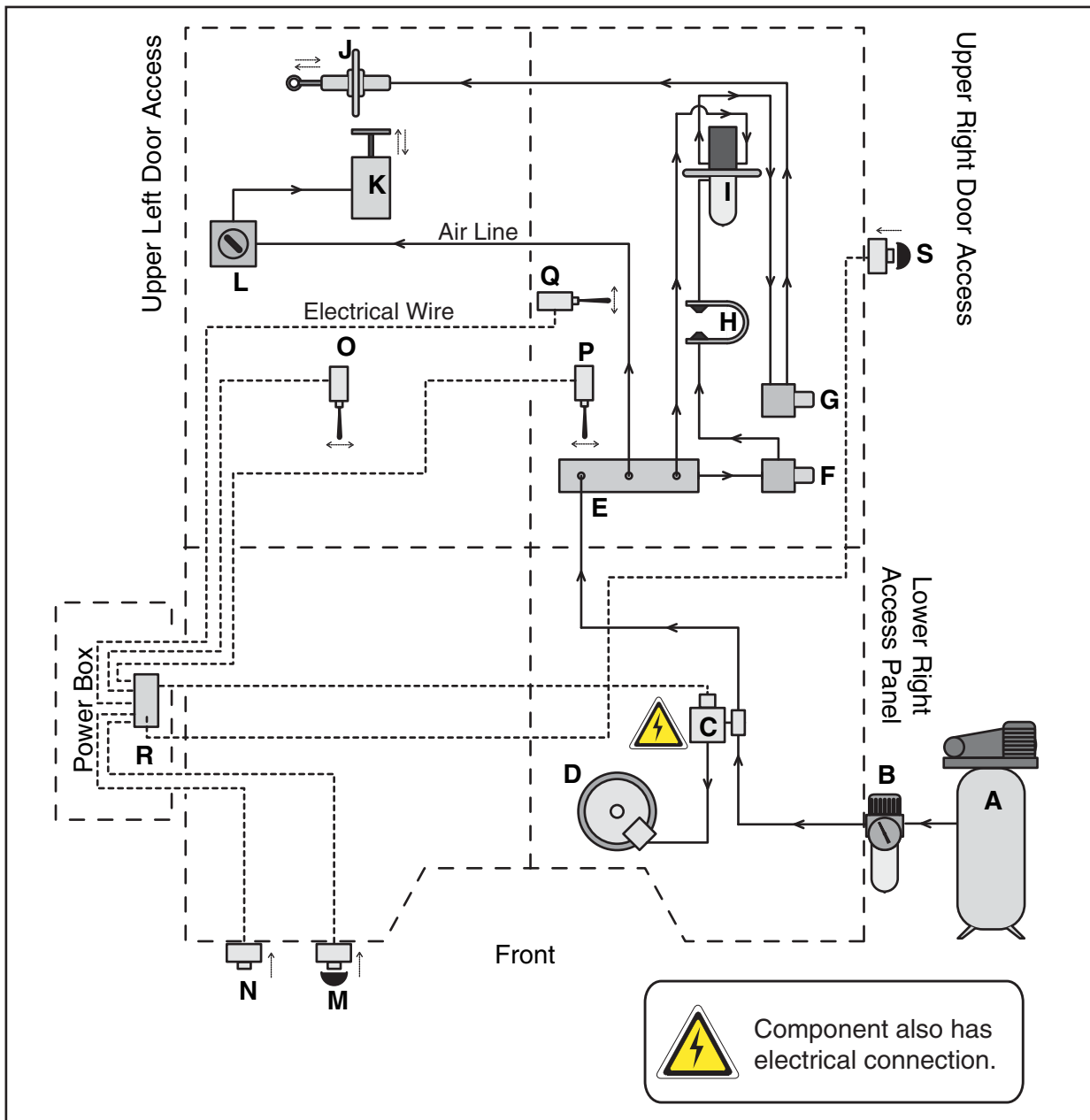

SECTION 8: WIRING

These pages are current at the time of printing. However, in the spirit of improvement, we may make changes to the electrical systems of future machines. Study this diagram carefully. If you notice differences between your machine and these wiring diagrams, call Technical Support at (570) 546-9663 for assistance.

WARNING

Electrical Safety Instructions

- 1. PRINTED INFORMATION.** The electrical information included in this section is current at the time of printing. However, in the spirit of improvement, we may make changes to the electrical system of future machines. Study the photos and diagrams in this section carefully. If you notice differences between your machine and these diagrams, call Technical Support at (570) 546-9663 for assistance.
- 2. FREQUENCY DRIVE.** The frequency drive inside the electrical cabinet was configured for your machine at the factory. It should not need any adjustment. Making changes to the frequency drive may cause damage to the machine and void the warranty.
- 3. SHOCK HAZARD.** Disconnect the power from the machine before servicing electrical components. Touching electrified parts will result in personal injury including but not limited to severe burns, electrocution, or death.
- 4. EXTENSION CORDS.** Using extension cords may reduce the performance and life of the machine. Instead, place the machine near the power source. If you must use an extension cord, use a grounded 12 gauge cord under 50 feet.
- 5. CIRCUIT REQUIREMENTS.** You **MUST** connect your machine to a grounded circuit that is rated for the amperage given on **Page 11**. **If you are unsure about the wiring codes in your area or you plan to connect your machine to a shared circuit, consult a qualified electrician.**
- 6. 220V SINGLE-PHASE POWER.** This machine uses a frequency drive to convert incoming single-phase power to 3-phase for greater spindle motor performance. Attempting to change this design may result in serious personal injury, damage to the machine, and may void the warranty.
- 7. GROUNDED CIRCUIT.** Electrocution or fire could result if the machine is not grounded and installed in compliance with electrical codes. Compliance **MUST** be verified by a qualified electrician.
- 8. MOTOR WIRING.** The motor wiring shown in these diagrams are current at the time of printing, but it may not match your machine. Always use the wiring diagram inside the motor junction box.
- 9. EXPERIENCING DIFFICULTIES.** If at any time you are experiencing difficulties understanding the information included in this section, contact our Technical Support at (570) 546-9663.

NOTICE

The photos and diagrams included in this section are best viewed in color. You can view these pages in color at www.grizzly.com.



Electrical Overview

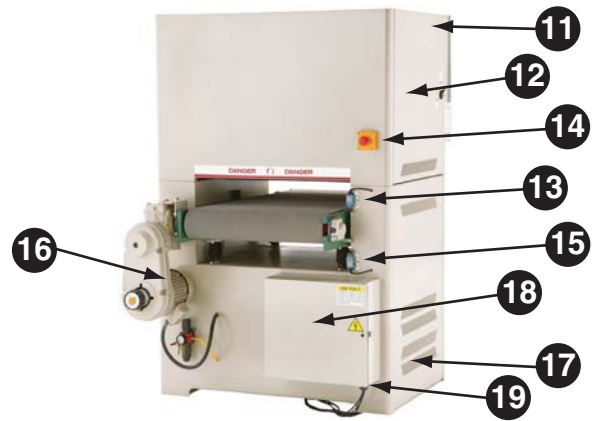

1	Amperage Meter (Page 66)
2	Control Panel (Page 66)
3	Right Belt Limit Switch (Page 67)
4	Upper Right Door Safety Switch (Page 67)
5	Belt Tension Limit Switch (Page 67)
6	Air Pressure Safety Switch (Page 68)
7	Lower Right Door Safety Switch (Page 68)
8	Main Motor (Page 68)
9	Table Elevation Sensor (Page 69)
10	Emergency Stop Bar Switch (Page 69)

11	Upper Left Door Safety Switch (Page 69)
12	Left Belt Limit Switch (Page 67)
13	Upper Table Limit Switch (Page 70)
14	Rear Emergency Stop Button (Page 67)
15	Lower Table Limit Switch (Page 70)
16	Feed Motor (Page 70)
17	Table Elevation Motor (Page 70)
18	Electrical Cabinet (Pages 63–65)
19	Power Source Connection

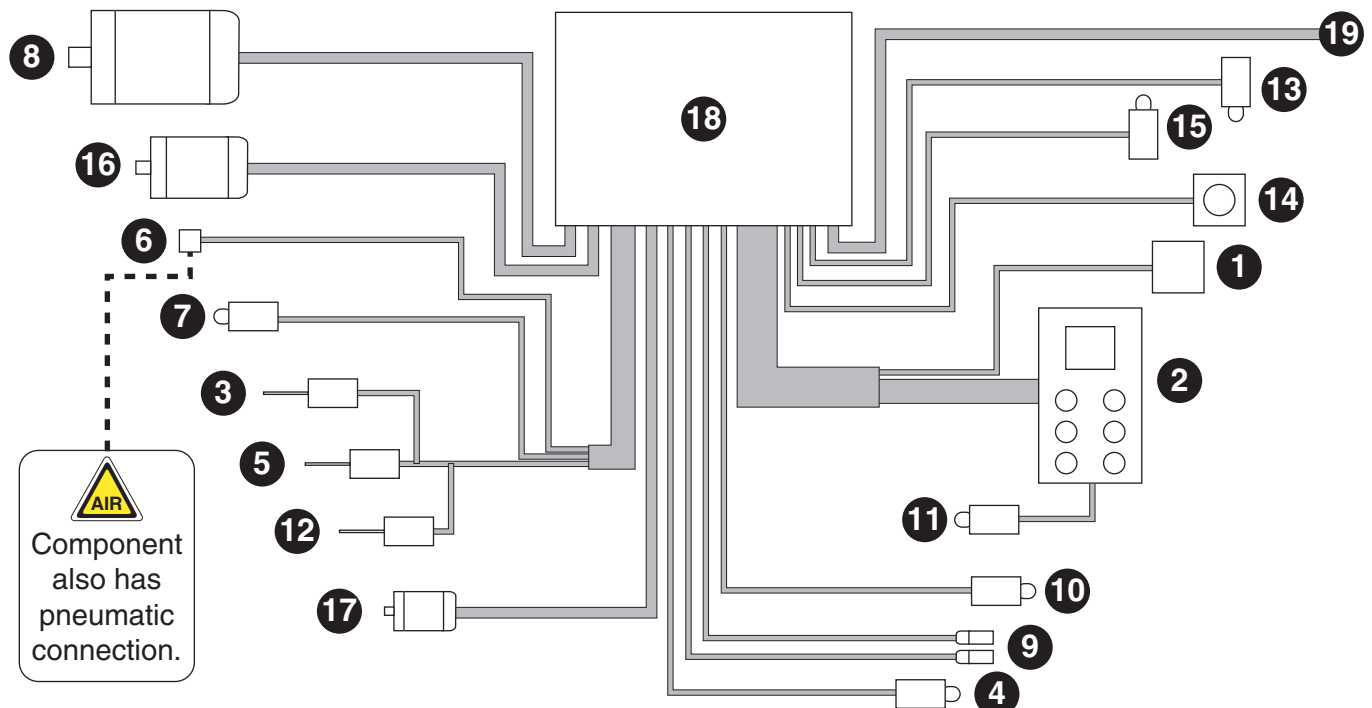

Electrical Cabinet

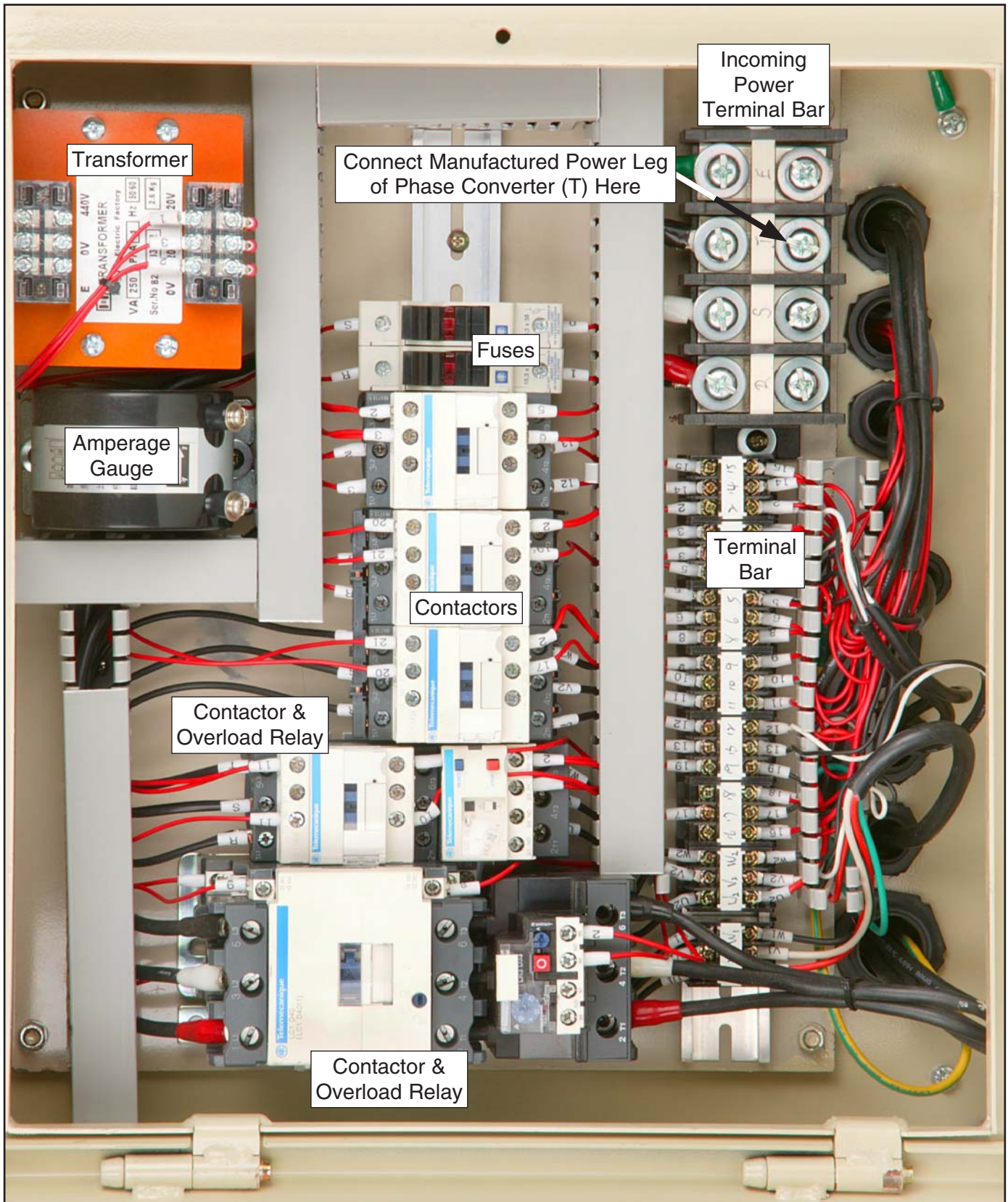

Figure 83. Electrical cabinet wiring.

Control Panel



Figure 84. Amperage meter wiring.

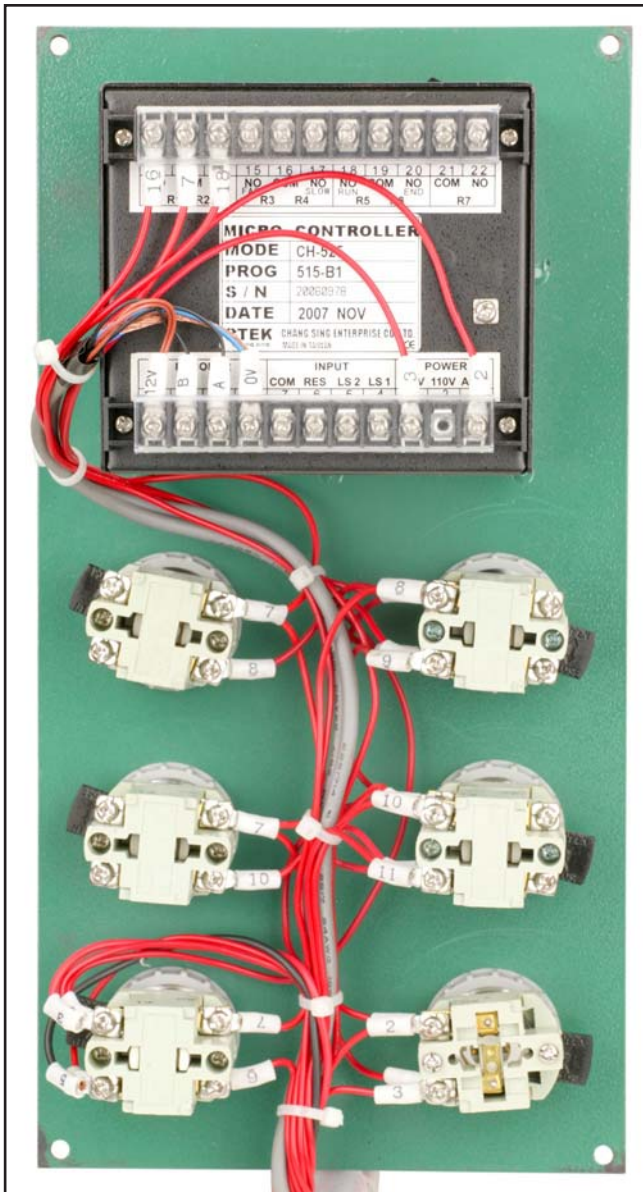
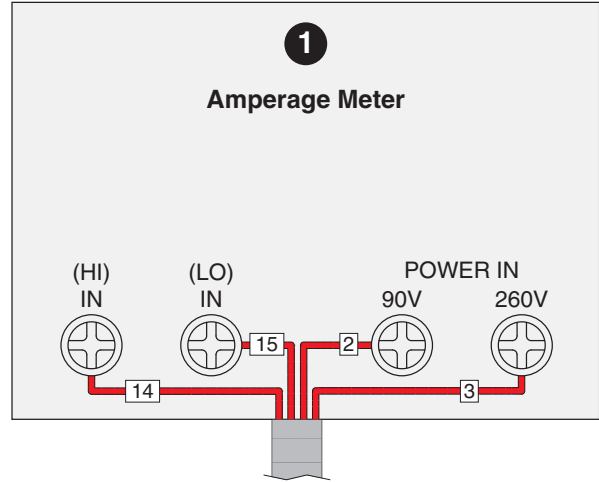
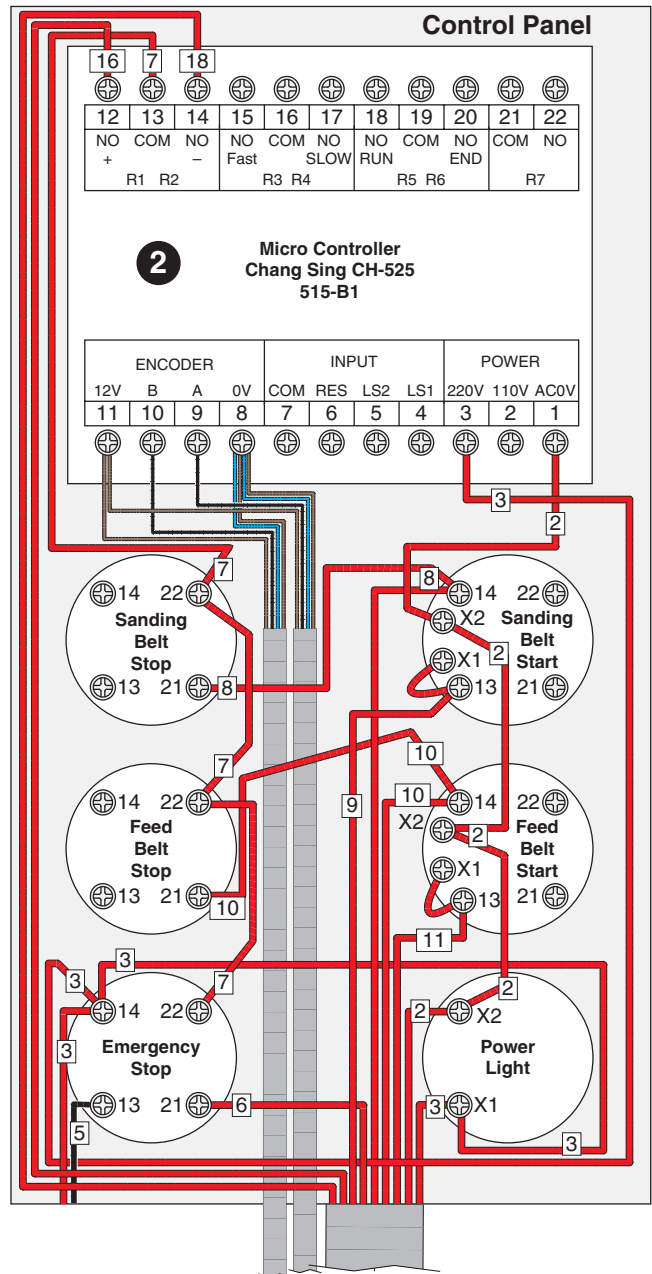

Figure 85. Control panel wiring.



Electrical Components A

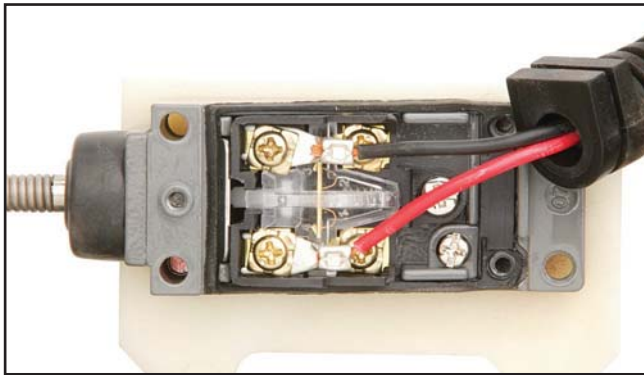

Figure 86. Belt limit switch wiring (left side).

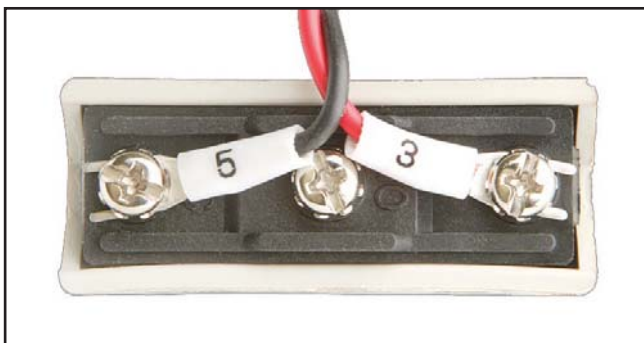

Figure 87. Upper right door safety switch wiring.

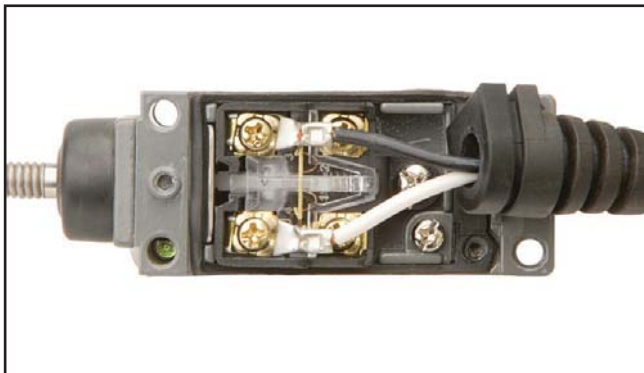
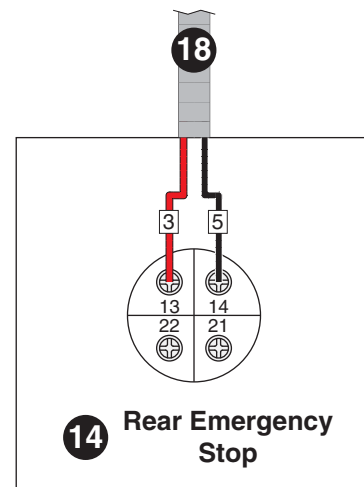
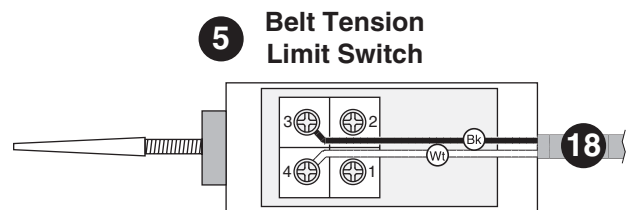
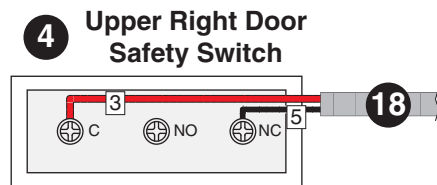
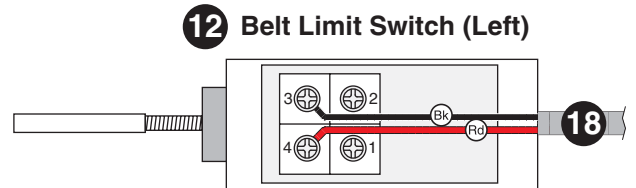
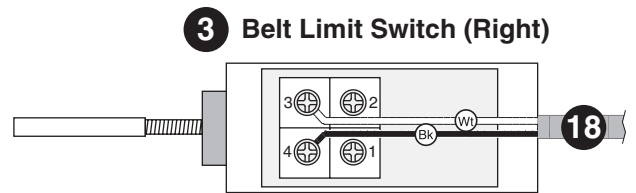

Figure 88. Belt tension limit switch wiring.



Figure 89. Rear emergency stop button wiring.



Electrical Components B



Figure 90. Air pressure limit switch wiring.

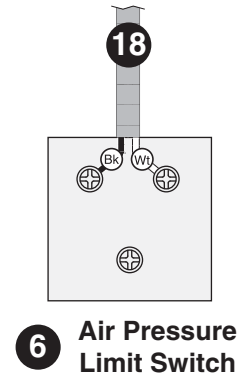

Figure 91. Lower right door safety switch wiring.

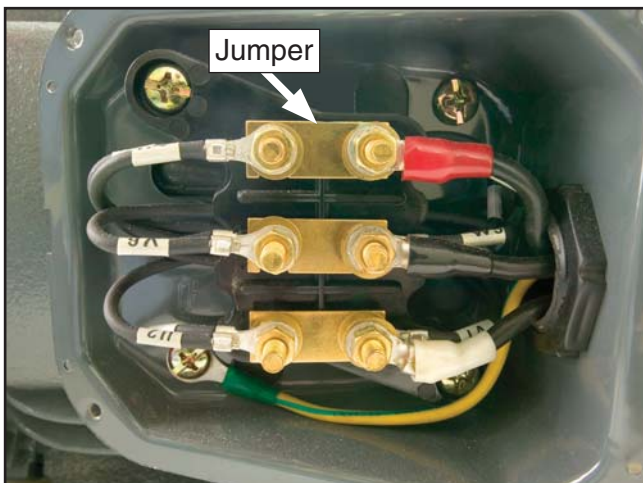
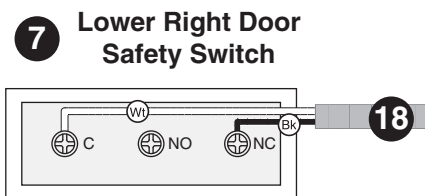
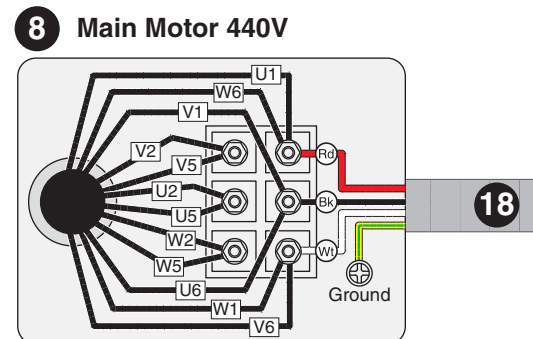
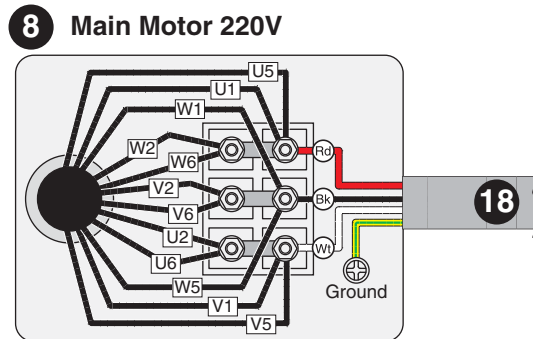

Figure 92. Main motor 220V wiring.



Note: Be sure to remove the jumpers (see **Figure 92**) from the main motor junction box when rewiring the motor to 440V.



Electrical Components C

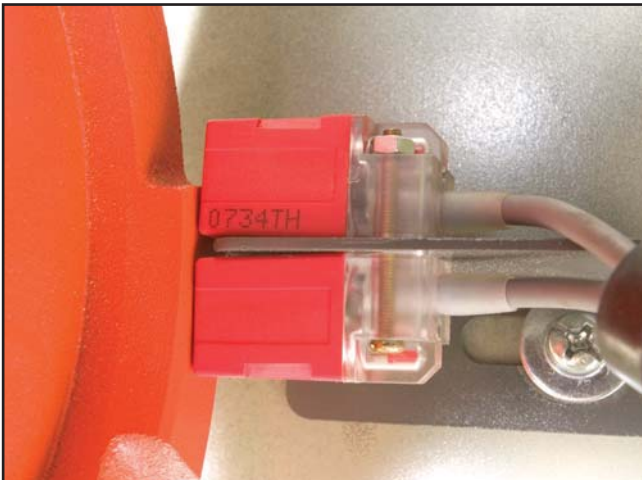

Figure 93. Table elevation sensor wiring.

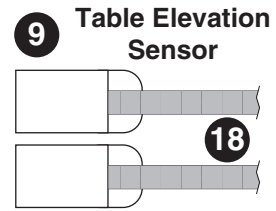

Figure 94. Emergency stop bar switch wiring.

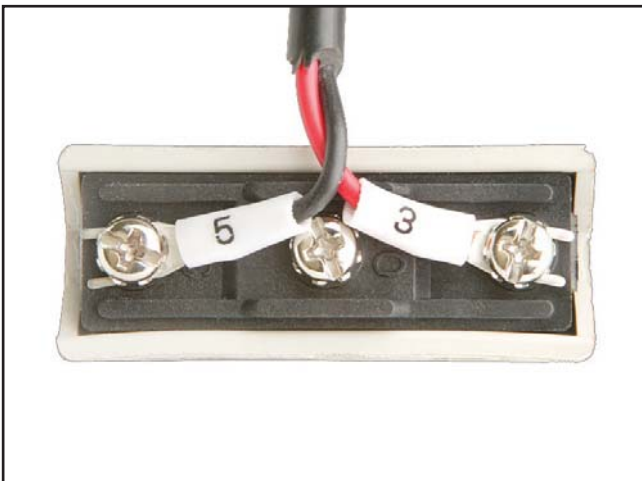
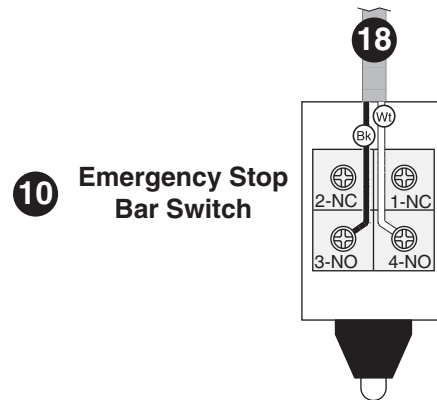
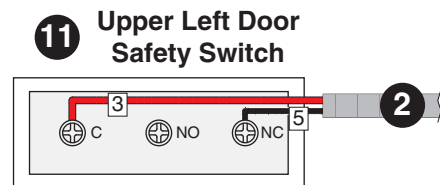

Figure 95. Upper left door safety switch wiring.



Electrical Components D



Figure 96. Lower table limit switch.

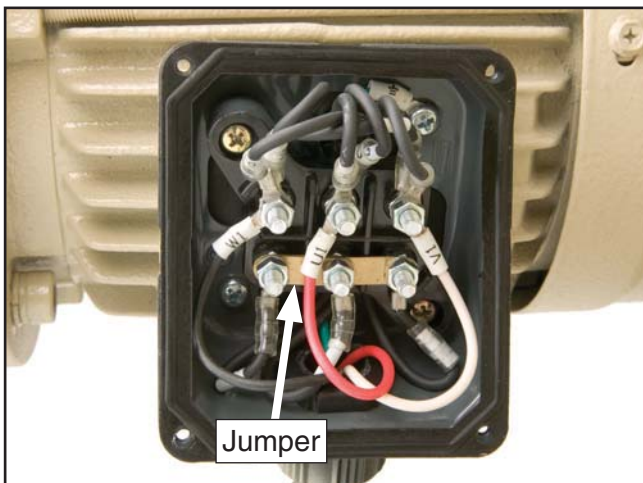

Figure 97. Feed motor 220V wiring.

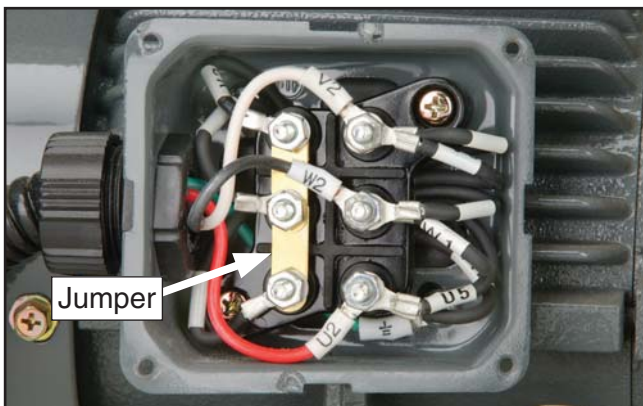
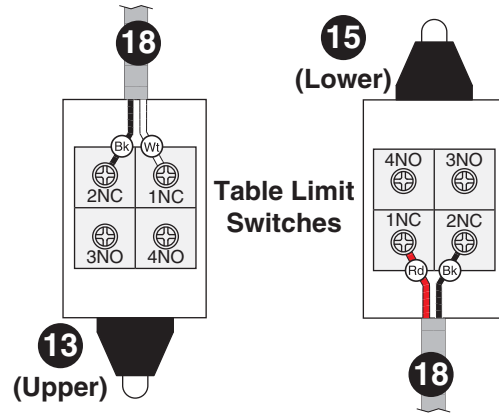
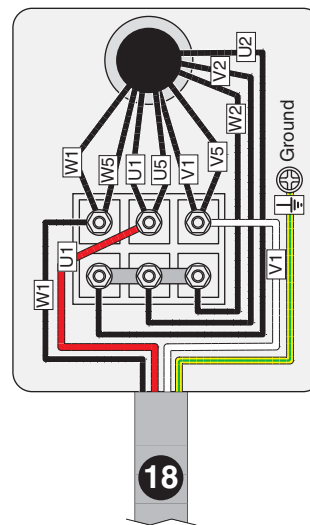

Figure 98. Elevation motor wiring.

Note: Be sure to remove the jumpers (see **Figures 97 & 98**) from the feed and elevation motor junction boxes when rewiring the motors to 440V.



16 Feed Motor 220V



16 Feed Motor 440V

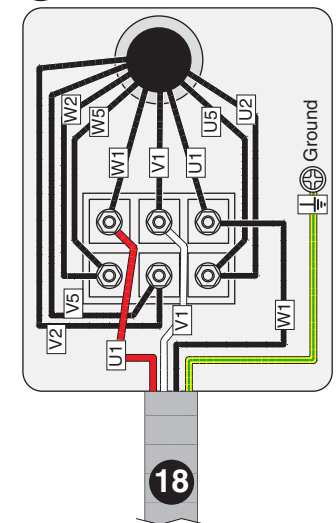

17 Elevation Motor 220V

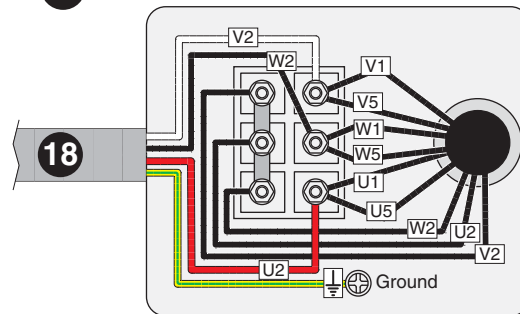

17 Elevation Motor 440V

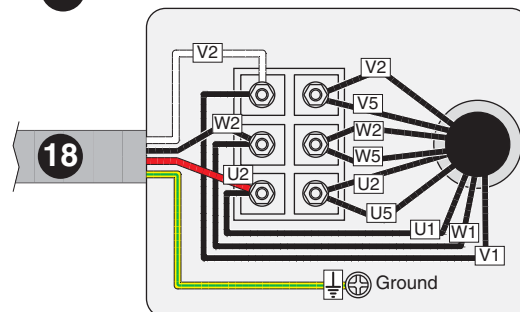

SECTION 9: PARTS

Tool Box & Accessories Breakdown 0000 Series Parts

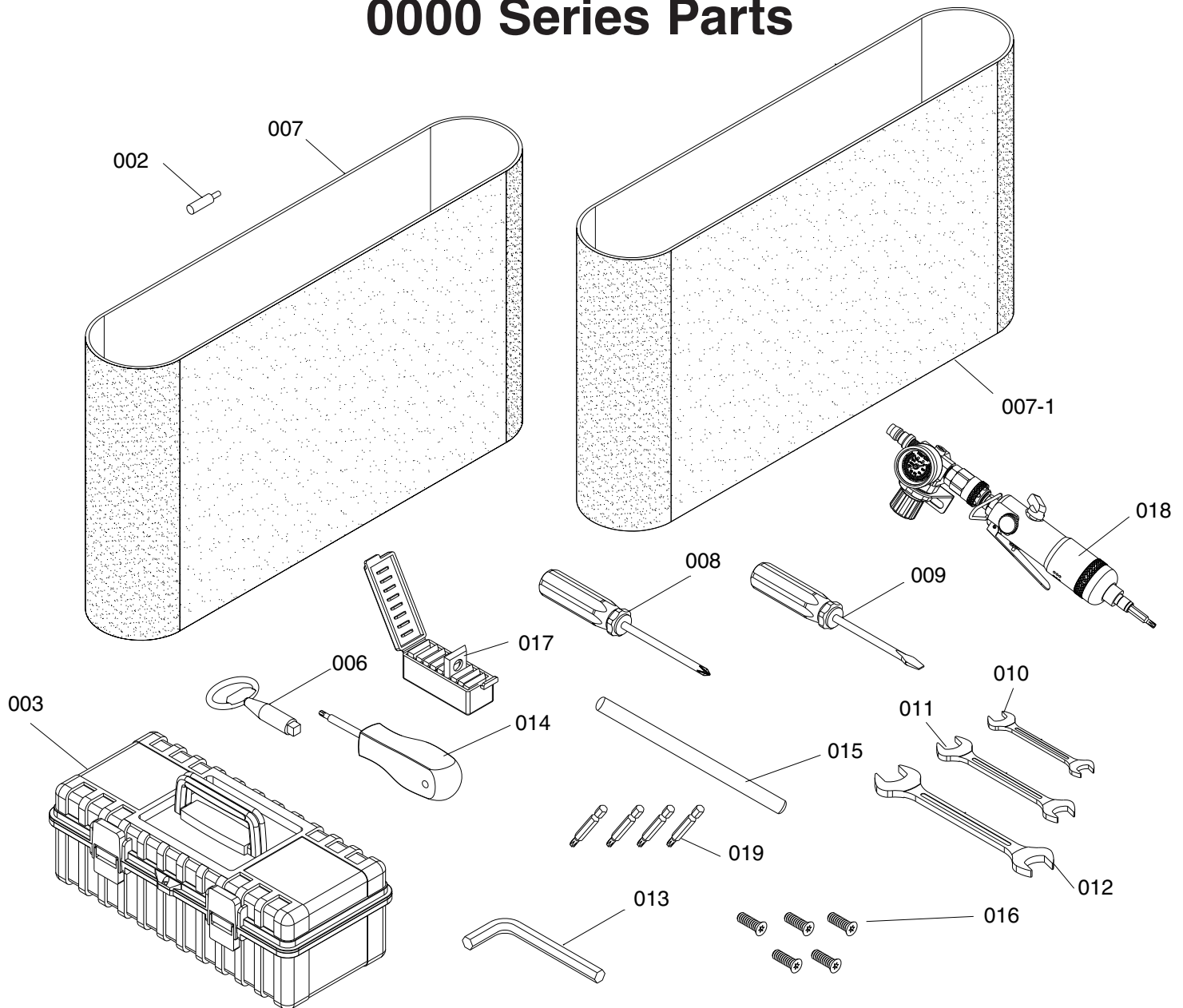

REF	PART #	DESCRIPTION
002	PH29330002	CERAMIC LIMIT SWITCH TIP
003	PH29330003	TOOL BOX
006	PH29330006	DOOR KEY
007	G8678	SANDING BELT (#120)
007-1	G8679	SANDING BELT (#150)
008	PSDP2	SCREWDRIVER PHILLIPS #2
009	PSDF2	SCREWDRIVER FLAT #2
010	PWR810	WRENCH 8 X 10
011	PWR1214	WRENCH 12 X 14

REF	PART #	DESCRIPTION
012	PWR1719	WRENCH 17 X 19
013	PH29330013	HEX WRENCH SET
014	P06770014	TORX SCREWDRIVER T-20
015	P06770015	BREAKER BAR
016	PFH15M	FLAT HD TORX SCR M6-1 X 12
017	P06770017	CARBIDE INSERTS 14 X 14 X 2 (QTY 10)
018	P06770018	PNEUMATIC TORX AIR TOOL
019	P06770019	TORX DRIVER T-20



Sanding Motor System Breakdown 1000 Series Parts

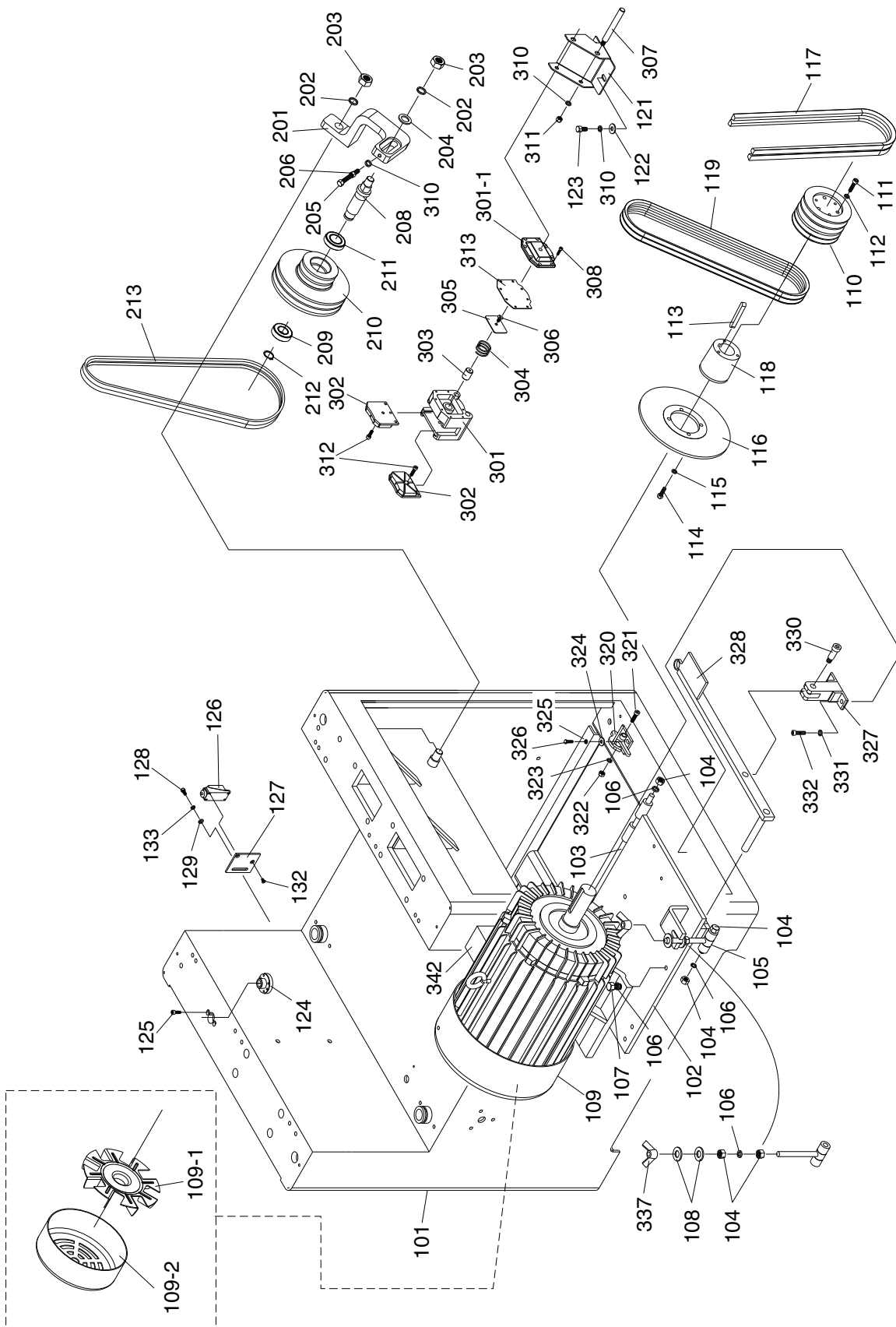

Sanding Motor System Parts List

REF	PART #	DESCRIPTION
101	P06771101	MACHINE FRAME
102	P06771102	MOTOR BASE
103	PH29331103	MOTOR BASE HINGE
104	PN41	HEX NUT 1/2-12
105	PH29331105	MOTOR BASE ADJ. ROD
106	PLW07	LOCK WASHER 1/2
107	PB41	HEX BOLT 1/2-12 X 1-1/2
108	PW01	FLAT WASHER 1/2
109	P06771109	MOTOR 15HP 220/440V 3PH
109-1	H29331109-1	MOTOR FAN
109-2	H29331109-2	MOTOR FAN COVER
110	P06771110	MOTOR PULLEY
111	PSB11	CAP SCREW 5/16-18 X 1-1/4
112	PLW01	LOCK WASHER 5/16
113	PH29331113	KEY 12 X 8 X 105
114	PB03	HEX BOLT 5/16-18 X 1
115	PLW01	LOCK WASHER 5/16
116	PH29331116	BRAKE ROTOR
117	P06771117	V-BELT B-74 5L770 QTY 2
118	PH29331118	PULLEY BUSHING
119	P06771119	V-BELT B-55 5L580 QTY 2
121	PH29331121	BRAKE BRACKET
122	PW02	FLAT WASHER 3/8
123	PB21	HEX BOLT 3/8-16 X 3/4
124	PH29331124	FLAT HEAD NUT
125	PSB05	CAP SCREW 1/4-20 X 3/4
126	PH29331126	TABLE LIMIT SWITCH
127	PH29331127	TABLE LIMIT SWITCH PLATE
128	PB02	HEX BOLT 1/4-20 X 5/8
129	PW06	FLAT WASHER 1/4
132	PFH30M	FLAT HD SCR M5-.8 X 8
133	PLW02	LOCK WASHER 1/4
201	P06771201	IDLER WHEEL ADJ. BRACKET
202	PLW10	LOCK WASHER 3/4
203	PN03	HEX NUT 3/4-16
204	PW13	FLAT WASHER 3/4

REF	PART #	DESCRIPTION
205	PB84	HEX BOLT 3/8-16 X 3-1/2
206	PN08	HEX NUT 3/8-16
208	PH29331208	IDLER WHEEL SHAFT
209	P6305	BALL BEARING 6305ZZ
210	P06771210	IDLER PULLEY
211	P6206	BALL BEARING 6206-ZZ
212	PR11M	EXT RETAINING RING 25MM
213	P06771213	V-BELT B52 5L540 QTY 2
301	PH29331301	BRAKE CALIPER
301-1	PH29331301-1	BRAKE CALIPER FRONT GUARD
302	PH29331302	BRAKE LINING SET
303	PH29331303	BRAKE ARBOR
304	PH29331304	BRAKE COMPRESSION SPRING
305	PH29331305	BRAKE INSIDE PIECE
306	PFH04	FLAT HD SCR 1/4-20 X 5/8
307	PH29331307	BRAKE PIN
308	PSB31	CAP SCREW 10-24 X 5/8
310	PLW04	LOCK WASHER 3/8
311	PN08	HEX NUT 3/8-16
312	PSB04	CAP SCREW 1/4-20 X 1/2
313	PH29331313	BRAKE GASKET
320	P06771320	FOOT PEDAL HOOK
321	PSB107	CAP SCREW 3/8-16 X 2
322	PN08	HEX NUT 3/8-16
323	PLW04	LOCK WASHER 3/8
324	PW07	FLAT WASHER 5/16
325	PLW01	LOCK WASHER 5/16
326	PB32	HEX BOLT 5/16-18 X 5/8
327	P06771327	FOOT PEDAL SUPPORTER
328	P06771328	FOOT PEDAL
330	P06771330	SPECIAL SCREW
331	PLW01	LOCK WASHER 5/16
332	PB09	HEX BOLT 5/16-18 X 1/2
337	P06771337	WING NUT 1/2
342	P06771342	WIRING COVER



Table Lift System Breakdown 2000 Series Parts

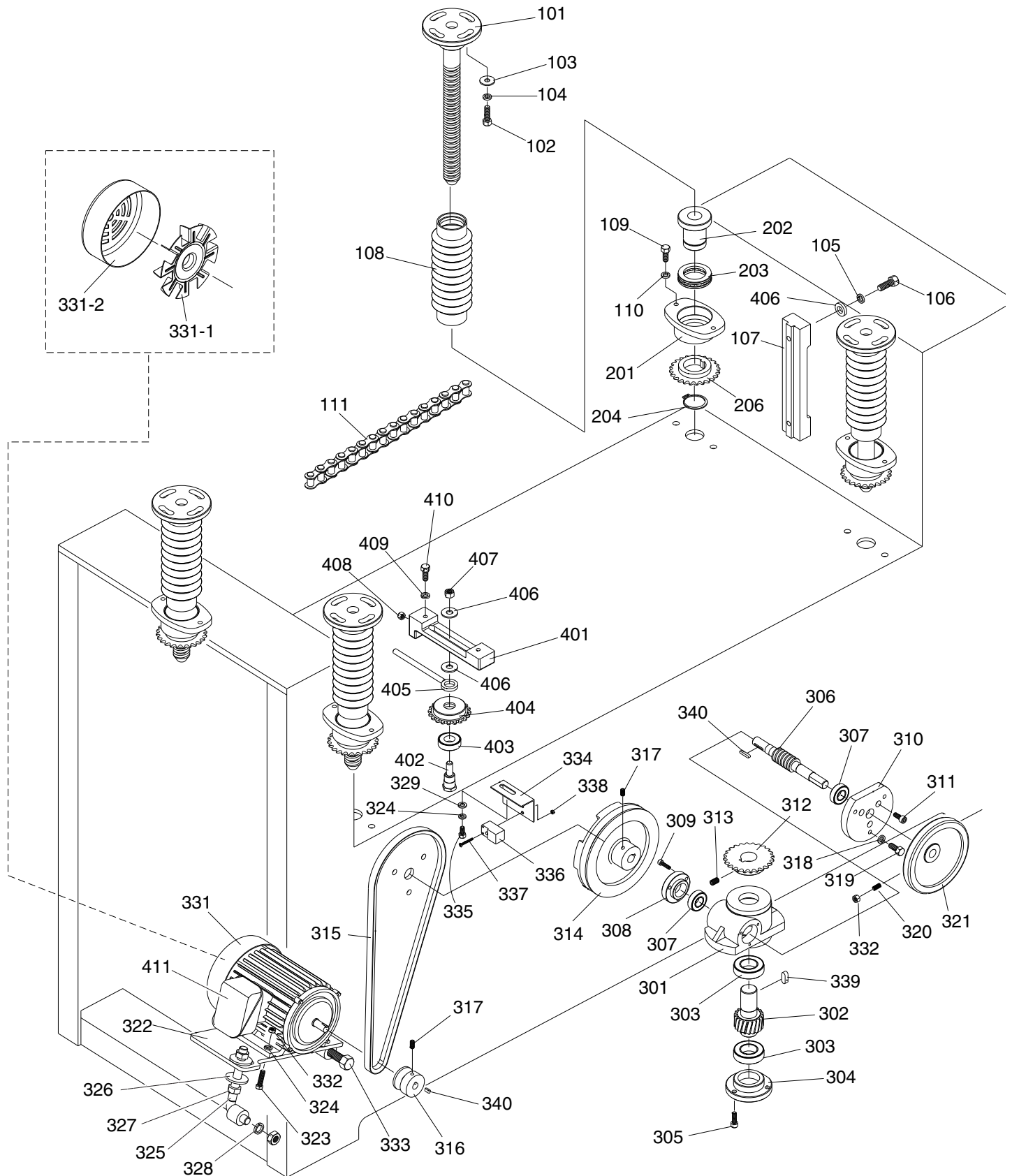

Table Lift System Parts List

REF	PART #	DESCRIPTION
101	PH29332101	ELEVATION SCREW
102	PB03	HEX BOLT 5/16-18 X 1
103	PW07	FLAT WASHER 5/16
104	PLW01	LOCK WASHER 5/16
105	PLW04	LOCK WASHER 3/8
106	PB18	HEX BOLT 3/8-16 X 1
107	PH29332107	ELEVATION SLIDE
108	PH29332108	DUST BOOT
109	PB07	HEX BOLT 5/16-18 X 3/4
110	PLW01	LOCK WASHER 5/16
111	PH29332111	CHAIN
201	PH29332201	NUT HOUSING
202	PH29332202	NUT
203	P51107	THRUST BEARING 51107
204	PR12M	EXT RETAINING RING 35MM
206	PH29332206	SPROCKET WHEEL
301	PH29332301	ELEVATION GEAR BOX
302	PH29332302	WORM GEAR
303	P6005	BALL BEARING 6005-ZZ
304	PH29332304	BEARING CAP
305	PSB05	CAP SCREW 1/4-20 X 3/4
306	PH29332306	WORM SHAFT
307	P6002	BALL BEARING 6002-ZZ
308	PH29332308	BEARING CAP
309	PSB31	CAP SCREW 10-24 X 5/8
310	PH29332310	BEARING CAP
311	PSB01	CAP SCREW 1/4-20 X 5/8
312	PH29332312	SPROCKET WHEEL
313	PSS08	SET SCREW 5/16-18 X 1/2
314	PH29332314	PULLEY
315	PVA36	V-BELT A-36 4L360
316	PH29332316	MOTOR PULLEY
317	PSS07	SET SCREW 1/4-20 X 1/2
318	PLW01	LOCK WASHER 5/16

REF	PART #	DESCRIPTION
319	PB07	HEX BOLT 5/16-18 X 3/4
320	PSS06	SET SCREW 1/4-20 X 3/4
321	PH29332321	HANDWHEEL
322	PH29332322	MOTOR BASE
323	PB31	HEX BOLT 1/4-20 X 1
324	PLW02	LOCK WASHER 1/4
325	PH29332325	ADJ. ROD
326	PW01	FLAT WASHER 1/2
327	PN41	HEX NUT 1/2-12
328	PLW07	LOCK WASHER 1/2
329	PW06	FLAT WASHER 1/4
331	PH29332331	MOTOR 1/4HP 220V/440V 3PH
331-1	PH29332331-1	MOTOR FAN
331-2	PH29332331-2	MOTOR FAN COVER
332	PN05	HEX NUT 1/4-20
333	PB89	HEX BOLT 1/2-12 X 4-1/2
334	PH29332334	PROXIMITY SWITCH PLATE
335	PB19	HEX BOLT 1/4-20 X 1/2
336	PH29332336	PROXIMITY SWITCH
337	P06772337	SPECIAL SCREW M3-.5 X 30
338	PN07M	HEX NUT M3-.5
339	PK14	KEY 5/16 X 5/16 X 3/4
340	PK48M	KEY 4 X 4 X 20
401	PH29332401	SPROCKET WHEEL ADJ.
402	PH29332402	SPROCKET WHEEL SHAFT
403	P6003	BALL BEARING 6003Z-Z
404	PH29332404	ADJ. SPROCKET
405	PH29332405	ADJ. ROD
406	PW02	FLAT WASHER 3/8
407	PN08	HEX NUT 3/8-16
408	PN02	HEX NUT 5/16-18
409	PLW01	LOCK WASHER 5/16
410	PB07	HEX BOLT 5/16-18 X 3/4
411	P06772411	WIRING COVER



Conveyor System Breakdown 3000 Series Parts

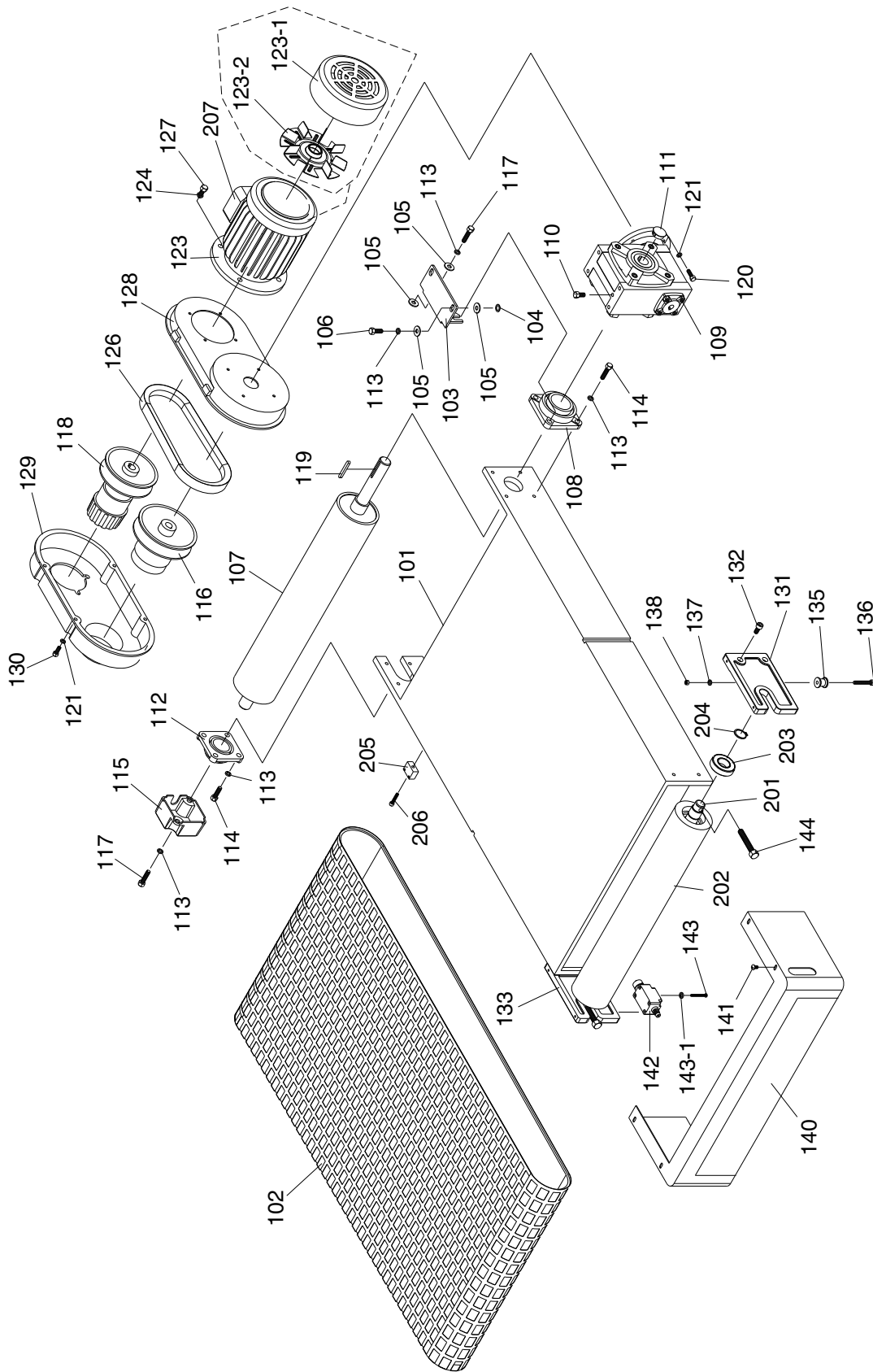

Conveyor System Parts List

REF	PART #	DESCRIPTION
101	PH29333101	CONVEYOR TABLE
102	PH29333102	CONVEYOR BELT
103	PH29333103	GEAR BOX FIXED PLATE
104	PH29333104	CUSHION
105	PW02	FLAT WASHER 3/8
106	PB32M	HEX BOLT M10-1.5 X 25
107	P06773107	OUTFEED ROLLER
108	PH29333108	BEARING UCF206
109	PH29333109	FEED BELT GEAR BOX
110	PH29333110	BREATHER
111	PH29333111	PLUG
112	PUCF205	BALL BEARING UCF205
113	PLW04	LOCK WASHER 3/8
114	PB24	HEX BOLT 3/8-16 X 1-1/4
115	PH29333115	BEARING CAP
116	PH29333116	DRIVE PULLEY
117	PB16	HEX BOLT 3/8-16 X 1-1/2
118	PH29333118	DRIVING PULLEY
119	PK151M	KEY 8 X 8 X 55
120	PB07M	HEX BOLT M8-1.25 X 25
121	PLW04M	LOCK WASHER 8MM
123	PH29333123	MOTOR 1HP 220V/440V 3PH
123-1	PH29333123-1	MOTOR FAN COVER
123-2	PH29333123-2	MOTOR FAN
124	PLW04	LOCK WASHER 3/8

REF	PART #	DESCRIPTION
126	PH29333126	TIMING BELT 1422V-290
127	PB32M	HEX BOLT M10-1.5 X 25
128	PH29333128	BASE PLATE
129	PH29333129	VARIABLE SPEED UNIT COVER
130	PSB14M	CAP SCREW M8-1.25 X 20
131	PH29333131	INFEED ROLLER BRACKET
132	PSB16	CAP SCREW 3/8-16 X 3/4
133	PH29333133	INFEED ROLLER BRACKET (L)
135	PH29333135	POSITION WHEEL
136	PSB70	CAP SCREW 5/16-18 X 2
137	PLW01	LOCK WASHER 5/16
138	PN02	HEX NUT 5/16-18
140	PH29333140	EMGNCY BRAKE PUSH PLATE
141	PS04	PHLP HD SCR 1/4-20 X 1/2
142	PH29333142	E-BRAKE LIMIT SWITCH
143	PS10	PHLP HD SCR 10-24 X 1-1/2
143-1	P06776322	SPRING GASKET 3/16
144	PB95	HEX BOLT 1/2-12 X 3
201	PH29333201	INFEED ROLLER SHAFT
202	PH29333202	INFEED ROLLER
203	P6206-RS	BALL BEARING 6206-RS
204	PR15M	EXT RETAINING RING 30MM
205	PH29333205	ELEVATION LIMITER
206	PSB62	CAP SCREW 1/4-20 X 1-1/2
207	P06773207	WIRING BOX



Feed, Drum, & Pressure Roller Breakdown 4000 Series Parts

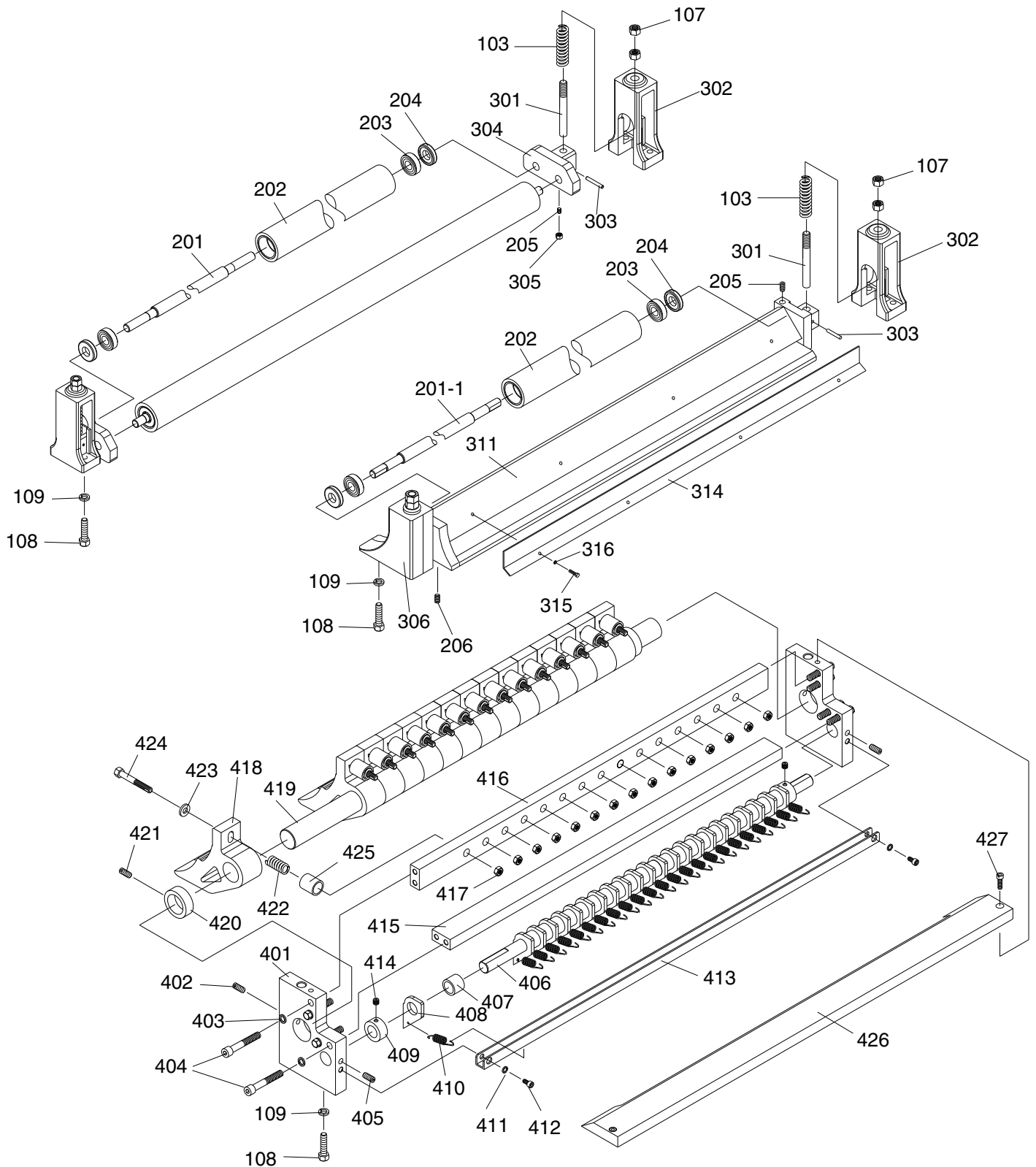

Feed, Drum, & Pressure Roller Parts List

REF	PART #	DESCRIPTION
103	P06774103	COMPRESSION SPRING
107	PN08	HEX NUT 3/8-16
108	PB12	HEX BOLT 5/16-18 X 1-1/4
109	PLW01	LOCK WASHER 5/16
201	P9962Z4201	PISTON ROLLER SHAFT
201-1	P04454201	PISTON ROLLER SHAFT
202	P9962Z4202	PISTON ROLLER
203	P6001	BALL BEARING 6001ZZ
204	P9962Z4204	SHAFT BEARING COLLAR
205	PSS06	SET SCREW 1/4-20 X 3/4
206	PSS07	SET SCREW 1/4-20 X 1/2
301	P9962Z4301	PISTON ROD
302	P9962Z4302	BRACKET
303	PRP55M	ROLL PIN 3 X 27
304	P99624304	SLIDE RAIL
305	PN05	HEX NUT 1/4-20
306	P04455301	BRACKET
311	P06774311	DEFLECTOR
314	P06774314	DUST GUARD PLATE
315	PB19	HEX BOLT 1/4-20 X 1/2
316	PLW02	LOCK WASHER 1/4
401	P06774401	CHIP BREAKER BRACKET
402	PSS08	SET SCREW 5/16-18 X 1/2
403	PLW01	LOCK WASHER 5/16

REF	PART #	DESCRIPTION
404	PSB08	CAP SCREW 5/16-18 X 1-1/2
405	PSS08	SET SCREW 5/16-18 X 1/2
406	P06774406	ANTI-KICKBACK FINGER SHAFT
407	P06774407	SPACER
408	P06774408	ANTI-KICKBACK FINGER PLATE
409	P06774409	FIXED BUSHING
410	P06774410	EXTENSION SPRING
411	PLW02	LOCK WASHER 1/4
412	PSB04	CAP SCREW 1/4-20 X 1/2
413	P06774413	SPRING BRACKET
414	PSS03	SET SCREW 1/4-20 X 3/8
415	P06774415	ANTI-KICKBACK FINGER BRACKET
416	P06774416	CHIP BREAKER SPRING BRACKET
417	P06774417	NYLON NUT 3/8
418	P06774418	CHIP BREAKER PAD
419	P06774419	CHIP BREAKER SHAFT
420	P06774420	CHIP BREAKER BUSHING
421	PSS10	SET SCREW 1/4-20 X 5/8
422	P06774422	COMPRESSION SPRING
423	PW02	FLAT WASHER 3/8
424	PB84	HEX BOLT 3/8-16 X 3-1/2
425	P06774425	SPACER
426	P06774426	CHIP BREAKER COVER
427	P06774427	SPECIAL CAP SCREW 1/4-20 x 5/8



Sanding Drum Breakdown 5000 Series Parts

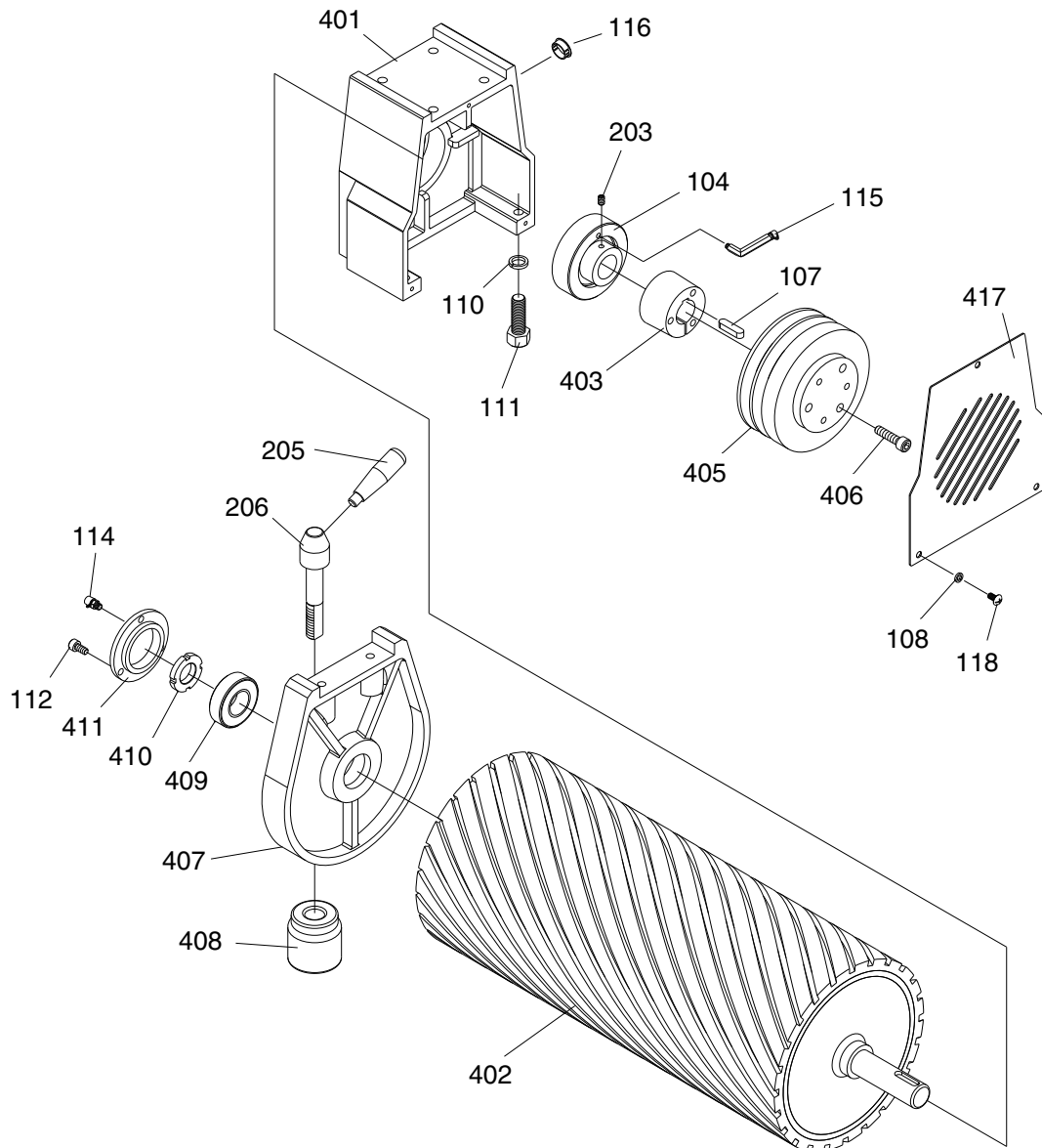

REF	PART #	DESCRIPTION
104	P9962Z5104	BEARING UCC206
107	PK11	KEY 5/16 X 5/16 X 1-3/16
108	PLW02	LOCK WASHER 1/4
110	PLW07	LOCK WASHER 1/2
111	PB41	HEX BOLT 1/2-12 X 1-1/2
112	PSB04	CAP SCREW 1/4-20 X 1/2
114	P9962Z5114	GREASE FITTING W/CAP
115	P06775115	GREASE FITTING W/CAP 90 DEG.
116	P9962Z5116	PLUG
118	PS07	PHLP HD SCR 1/4-20 X 3/8
203	PSS02M	SET SCREW M6-1 X 6
205	P9962Z5205	HANDLE

REF	PART #	DESCRIPTION
206	P9962Z5206	ROLLER LOCKDOWN SHAFT
401	P9962Z5401	BEARING HOUSING
402	P9962Z5402	ROLLER
403	P9962Z5403	FASTENING TUBE
405	P9962Z5405	PULLEY
406	PSB11	CAP SCREW 5/16-18 X 1-1/4
407	P9962Z5407	BEARING HOUSING
408	P9962Z5408	BRACKET PAD
409	P6206-2RS	BALL BEARING 6206-2RS
410	P9962Z5410	SPANNER NUT
411	P9962Z5411	BEARING CAP
417	P9962Z5417	COVER



Helical Cutterhead Breakdown 5000 Series Parts

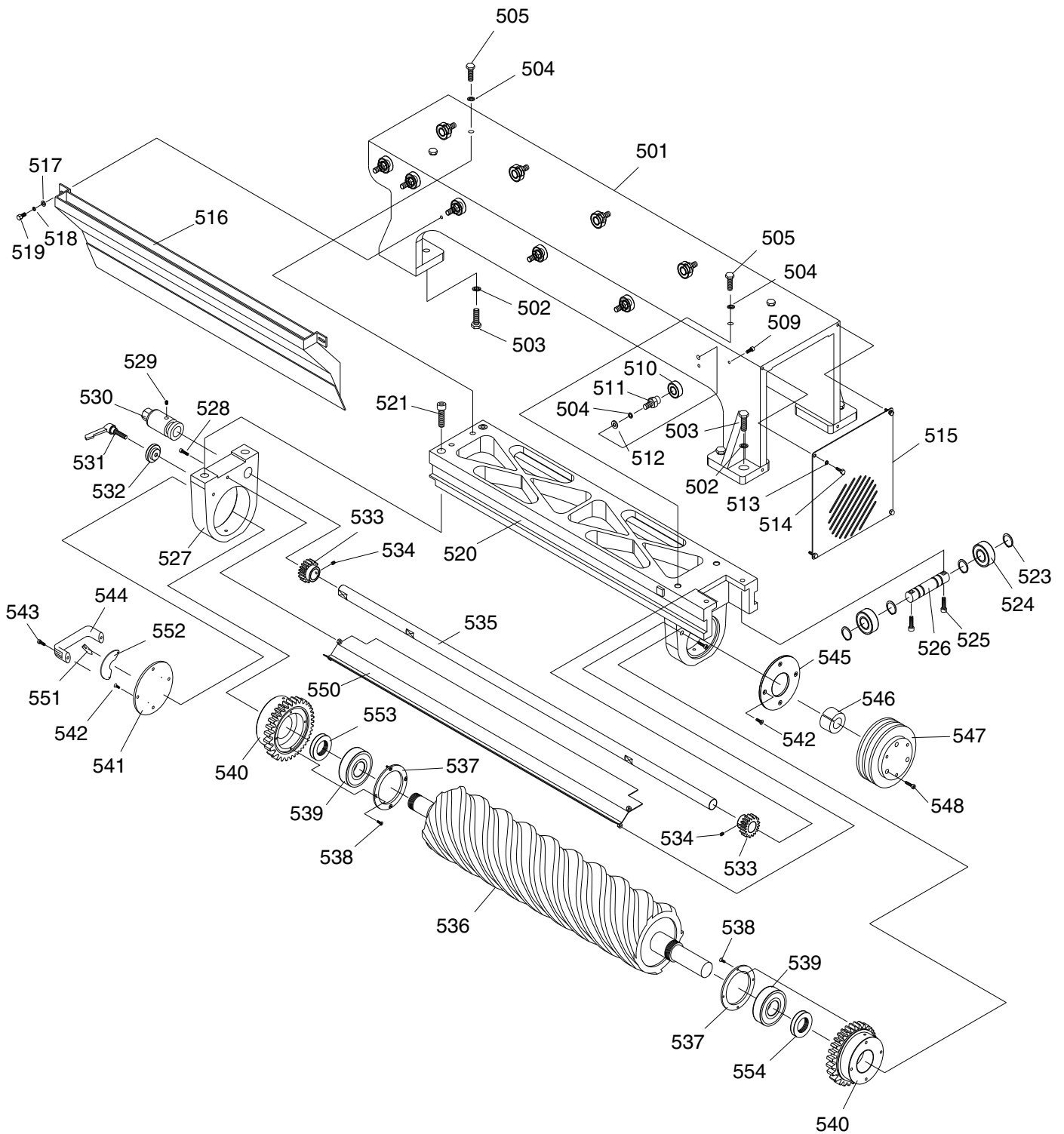

Helical Cutterhead Parts List

REF	PART #	DESCRIPTION
501	P06775501	HELICAL CUTTERHEAD BASE
502	PLW07	LOCK WASHER 1/2
503	PB41	HEX BOLT 1/2-12 X 1-1/2
504	PLW07	LOCK WASHER 1/2
505	PB41	HEX BOLT 1/2-12 X 1-1/2
509	P06775509	SPECIAL SCREW 5/16-18 X 3/4
510	P6003	BALL BEARING 6003-ZZ
511	P06775511	SLIDER SHAFT
512	PW01	FLAT WASHER 1/2
513	PLW02	LOCK WASHER 1/4
514	PS07	PHLP HD SCR 1/4-20 X 3/8
515	P06775515	COVER
516	P06775516	AIR CHUTE
517	PW07	FLAT WASHER 5/16
518	PLW01	LOCK WASHER 5/16
519	PB09	HEX BOLT 5/16-18 X 1/2
520	P06775520	HELICAL CUTTERHEAD BRACKET
521	PSB79	CAP SCREW 1/2-12 X 3-1/2
523	PR15M	EXT RETAINING RING 30MM
524	P6206-2RS	BALL BEARING 6206-2RS
525	PSB78	CAP SCREW 1/2-12 X 1
526	P06775526	SHAFT OF SLIDER
527	P06775527	BEARING HOUSING SEAT
528	PSB62	CAP SCREW 1/4-20 X 1-1/2
529	PSS08	SET SCREW 5/16-18 X 1/2

REF	PART #	DESCRIPTION
530	P06775530	ADJ. SHAFT
531	P06775531	ADJ. HANDLE
532	P06775532	TIGHTEN CUSHION
533	P06775533	GEAR WHEEL
534	PSS02	SET SCREW 5/16-18 X 3/8
535	P06775535	ELEVATOR DRIVEN SHAFT
536	P06775536	HELICAL CUTTERHEAD
537	P06775537	BEARING HOUSING COVER
538	PFH08	FLAT HD SCR 10-24 X 1/2
539	P6206-2RS	BALL BEARING 6206-2RS
540	P06775540	BEARING HOUSING
541	P06775541	BEARING COVER (L)
542	PFH03	FLAT HD SCR 1/4-20 X 1/2
543	PSB07	CAP SCREW 5/16-18 X 3/4
544	P06775544	CUTTERHEAD SLIDE HANDLE
545	P06775545	BEARING COVER (R)
546	P06775546	PULLEY TUBE
547	P9962Z1110	PULLEY
548	PSB11	CAP SCREW 5/16-18 X 1-1/4
550	P06775550	PILOT OF AIR CHUTE
551	P06775551	VERNIER CALIPER POINTER
552	P06775552	VERNIER CALIPER
553	P06775553	SPACER
554	P06775554	SPACER



Upper Roller System Breakdown 6000 Series Parts

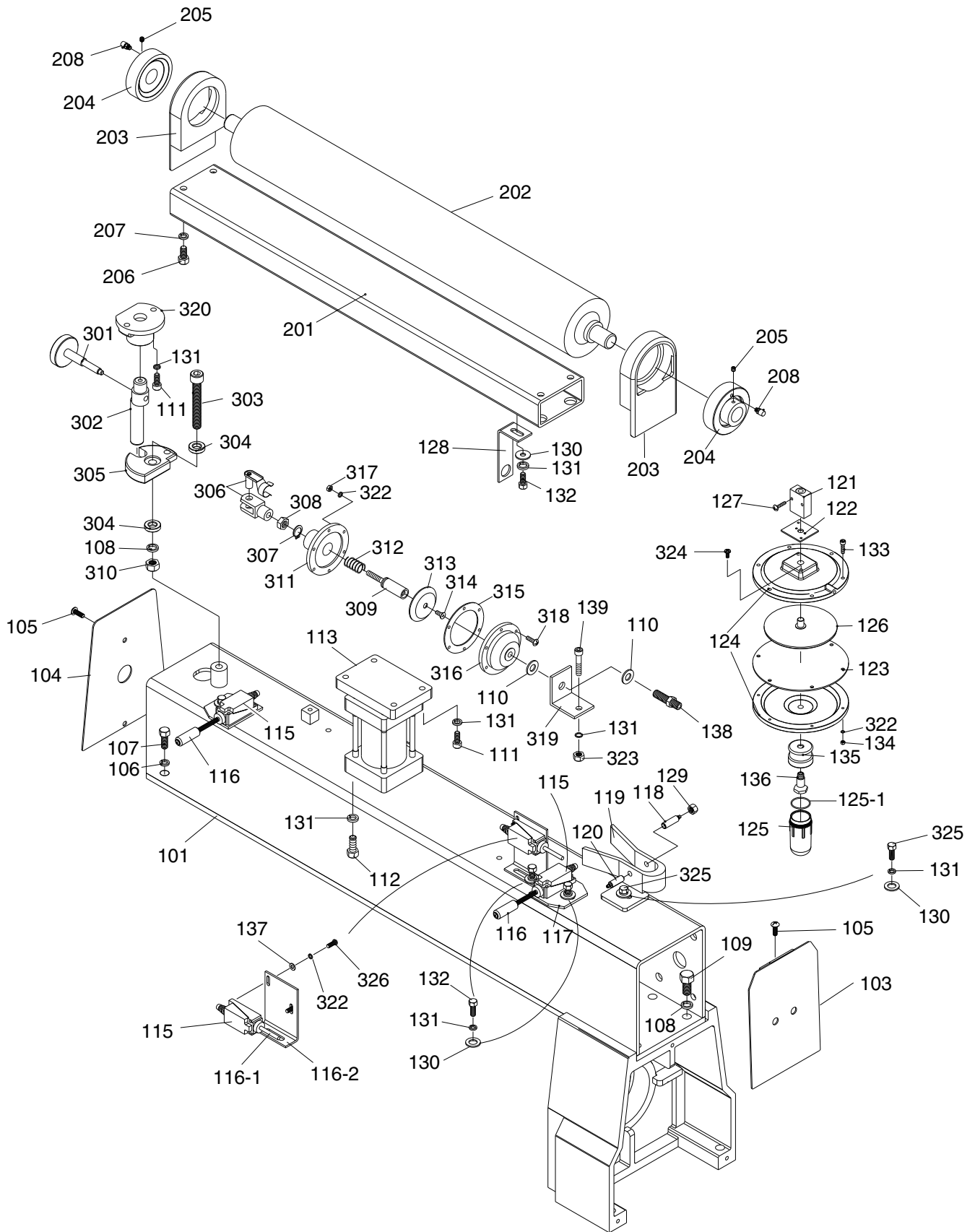

Upper Roller System Parts List

REF	PART #	DESCRIPTION
101	P9962Z6101	SQUARE FRAME
103	P9962Z6103	FRAME SEAL (R)
104	P9962Z6104	FRAME SEAL (L)
105	PFH03	FLAT HD SCR 1/4-20 X 1/2
106	PLW04	LOCK WASHER 3/8
107	PB18	HEX BOLT 3/8-16 X 1
108	PLW07	LOCK WASHER 1/2
109	PSB78	CAP SCREW 1/2-12 X 1
110	PH29333104	CUSHION
111	PSB07	CAP SCREW 5/16-18 X 3/4
112	PB09M	HEX BOLT M8-1.25 X 20
113	P9962Z6113	AIR CYLINDER
115	P9962Z6115	LIMIT SWITCH
116	P9962Z6116	LIMIT SWITCH TUBE - CERAMIC
116-1	P9962Z6116-1	LIMIT SWITCH TUBE - PLASTIC
116-2	P9962Z6116-2	LIMIT SWITCH HOLDER - L TYPE
117	P9962Z6117	LIMIT SWITCH HOLDER
118	P9962Z6118	AIR SENSOR NOZZLE (FEMALE)
119	P9962Z6119	AIR CYLINDER BRACKET
120	P9962Z6120	AIR SENSOR NOZZLE (MALE)
121	P9962Z6121	THROTTLE VALVE
122	P9962Z6122	THROTTLE VALVE BASE
123	P9962Z6123	PLATE
124	P9962Z6124	ALUMINUM DISC
125	P9962Z6125	OIL CUP
125-1	P9962Z6125-1	CUSHION
126	P9962X6126	ALUMINUM PLATE
127	PS52M	PHLP HD SCR M4-.7 X 20
128	P9962Z6128	BRACKET
129	PN11	HEX NUT 3/8-24
130	PW07	FLAT WASHER 5/16
131	PLW01	LOCK WASHER 5/16
132	PB09	HEX BOLT 5/16-18 X 1/2
133	PSB33	CAP SCREW 10-24 X 3/4
134	PN07	HEX NUT 10-24
135	P9962Z6135	OIL CUP CONNECTOR
136	P9962Z6136	OIL CUP SHAFT

REF	PART #	DESCRIPTION
137	PW03	FLAT WASHER #10
138	P06776138	CONNECTOR 1/8T X 3/8-24U
139	PSB08	CAP SCREW 5/16-18 X 1-1/2
201	P9962Z6201	UPPER ROLLER BRACKET
202	P9962Z6202	UPPER ROLLER
203	P9962Z6203	UPPER ROLLER BRACKET
204	P9962Z6204	BEARING UCC205
205	PSS02M	SET SCREW M6-1 X 6
206	PSB16	CAP SCREW 3/8-16 X 3/4
207	PLW04	LOCK WASHER 3/8
208	P9962Z6208	GREASE FITTING
301	P9962Z6301	TRIMMING ADJUSTER
302	P9962Z6302	ECCENTRIC ROD
303	PSB79	CAP SCREW 1/2-12 X 3-1/2
304	P06776304	GASKET 1/2
305	P9962Z6305	ECCENTRIC PIECE
306	P9962Z6306	UNIVERSAL JOINT FORK
307	PR05M	EXT RETAINING RING 15MM
308	PN02M	HEX NUT M10-1.5
309	P9962Z6309	AIR CYLINDER SHAFT
310	PN41	HEX NUT 1/2-12
311	P9962Z6311	BOTTOM COVER
312	P9962Z6312	COMPRESSION SPRING
313	P9962Z6313	ALUMINUM PLATE
314	PS14M	PHLP HD SCR M6-1 X 12
315	P9962Z6315	PLATE
316	P9962Z6316	TOP COVER
317	PN07	HEX NUT 10-24
318	PSB33	CAP SCREW 10-24 X 3/4
319	P9962Z6319	AIR CYLINDER BRACKET
320	P9962Z6320	ECCENTRIC SHAFT COLLAR
322	PLW03	LOCK WASHER 10-24
323	PN02	HEX NUT 5/16-18
324	PFH25M	FLAT HD SCR M4-.7 X 12
325	PB07	HEX BOLT 5/16-18 X 3/4
326	PS05M	PHLP HD SCR M5-.8 X 8



Cabinet Assembly Breakdown 7000 Series Parts

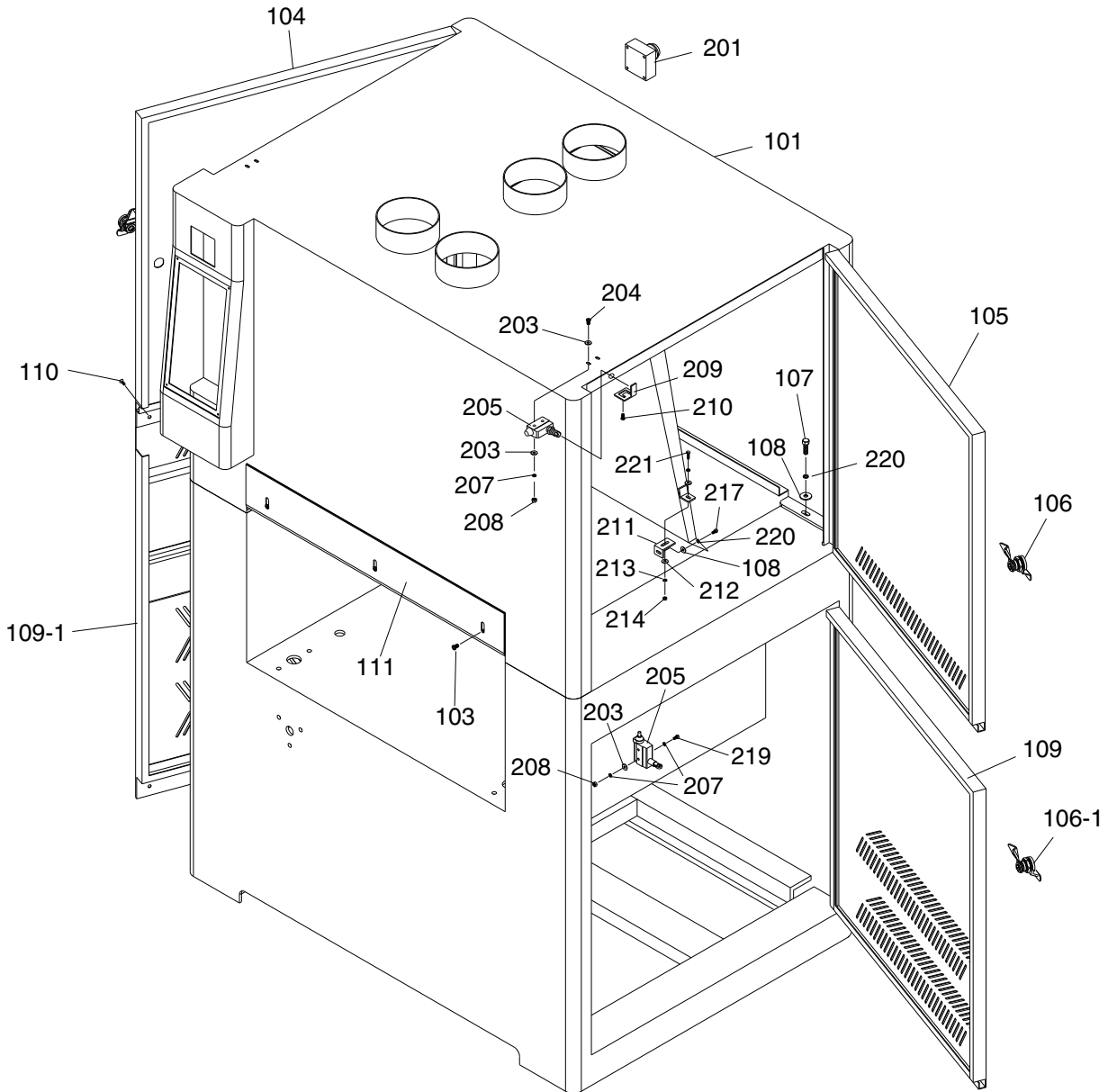

REF	PART #	DESCRIPTION
101	P06777101	UPPER FRAME COVER
103	PS68M	PHLP HD SCR M6-1 X 10
104	PH29337104	UPPER LEFT DOOR
105	PH29337105	UPPER RIGHT DOOR
106	PH29337106	DOOR LOCK
106-1	PH29337106-1	DOOR LOCK (LOWER FRAME)
107	PSB07	CAP SCREW 5/16-18 X 3/4
108	PW07	FLAT WASHER 5/16
109	P06777109	RIGHT DOOR, LOWER FRAME
109-1	PH29337109-1	LEFT DOOR, LOWER FRAME
110	PFH03	FLAT HD SCR 1/4-20 X 1/2
111	PH29337111	EMERGENCY STOP PLATE
201	P06777201	EMERGENCY STOP SWITCH
203	PW08	FLAT WASHER #8

REF	PART #	DESCRIPTION
204	P06777204	PHLP HD SCR #8-32 X 1-1/4
205	P06777205	POWER OFF SWITCH
207	PLW11	LOCK WASHER #8
208	PN14	HEX NUT #8-32
209	P06777209	LIMIT SWITCH HOLDER
210	PS03M	PHLP HD SCR M6-1 X 8
211	P06777211	AIR CHUTE FIX PLATE
212	PW06	FLAT WASHER 1/4
213	PLW02	LOCK WASHER 1/4
214	PN05	HEX NUT 1/4-20
217	PB09	HEX BOLT 5/16-18 X 1/2
219	P06777219	PHLP HD SCR #8-32 X 1-1/2
220	PLW01	LOCK WASHER 5/16
221	P06777221	HEX BOLT 1/4 X 3/4



Main Wiring Panel & Controls Breakdown 8000 Series Parts

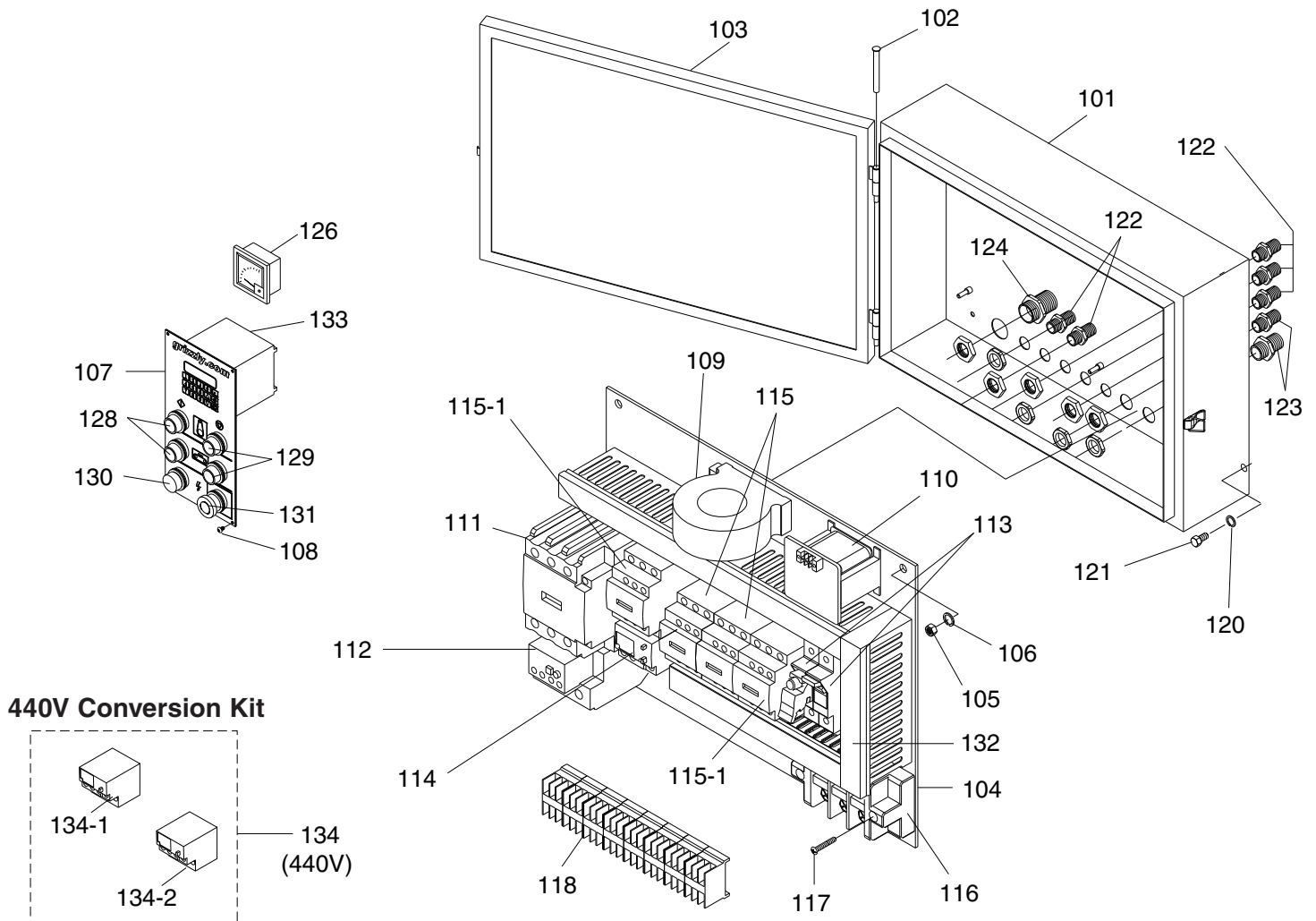

440V Conversion Kit

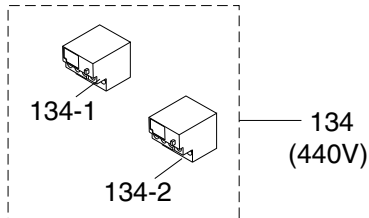

REF	PART #	DESCRIPTION
101	PH29338101	ELECTRICAL CONTROL BOX
102	PH29338102	HINGE
103	PH29338103	DOOR
104	PH29338104	BASE PLATE
105	PN05	HEX NUT 1/4-20
106	PLW02	LOCK WASHER 1/4
107	PH29338107	CONTROL PANEL
108	PS07M	PHLP HD SCR M4-.7 X 8
109	PH29338109	CURRENT SENSOR
110	PH29338110	TRANSFORMER
111	PH29338111	CONTACTOR LC1-D40
112	PH29338112	RELAY LR3D-3355 220V (30-40A)
113	PH29338113	FUSE TE10.3 X 38 & 500V/4A X 2
114	PH29338114	RELAY LR3D-086 220V (2.5-4A)
115	PH29338115	CONTACTOR LC1-D096 (WITH LOCK)
115-1	PH29338115-1	CONTACTOR LC1-D096

REF	PART #	DESCRIPTION
116	PH29338116	POWER WIRE TERMINAL
117	PS51M	PHLP HD SCR M4-.7 X 30
118	PH29338118	TERMINAL PLATE
120	PLW02	LOCK WASHER 1/4
121	PB19	HEX BOLT 1/4-20 X 1/2
122	PH29338122	PU CONNECTOR 1/2"
123	PH29338123	PU CONNECTOR 1/4"
124	PH29338124	CABLE CONNECTOR 1"
126	PH29338126A	DIGITAL AMP METER V2.02.06
128	PH29338128	START SWITCH
129	PH29338129	STOP SWITCH
130	PH29338130	POWER INDICATION LIGHT
131	PH29338131	EMERGENCY STOP SWITCH
132	PH29338132	WIRE COLUMN
133	PH29338133	COMPUTER

440V Conversion Kit

REF	PART #	DESCRIPTION
134	P06778134	440V CONVERSION KIT
134-1	PH29338134	RELAY LR3D-3322 440V (17-25A)
134-2	PH29338135	RELAY LR3D-076 440V (1.6-2.5A)



Belt Oscillation System Breakdown

9000 Series Parts

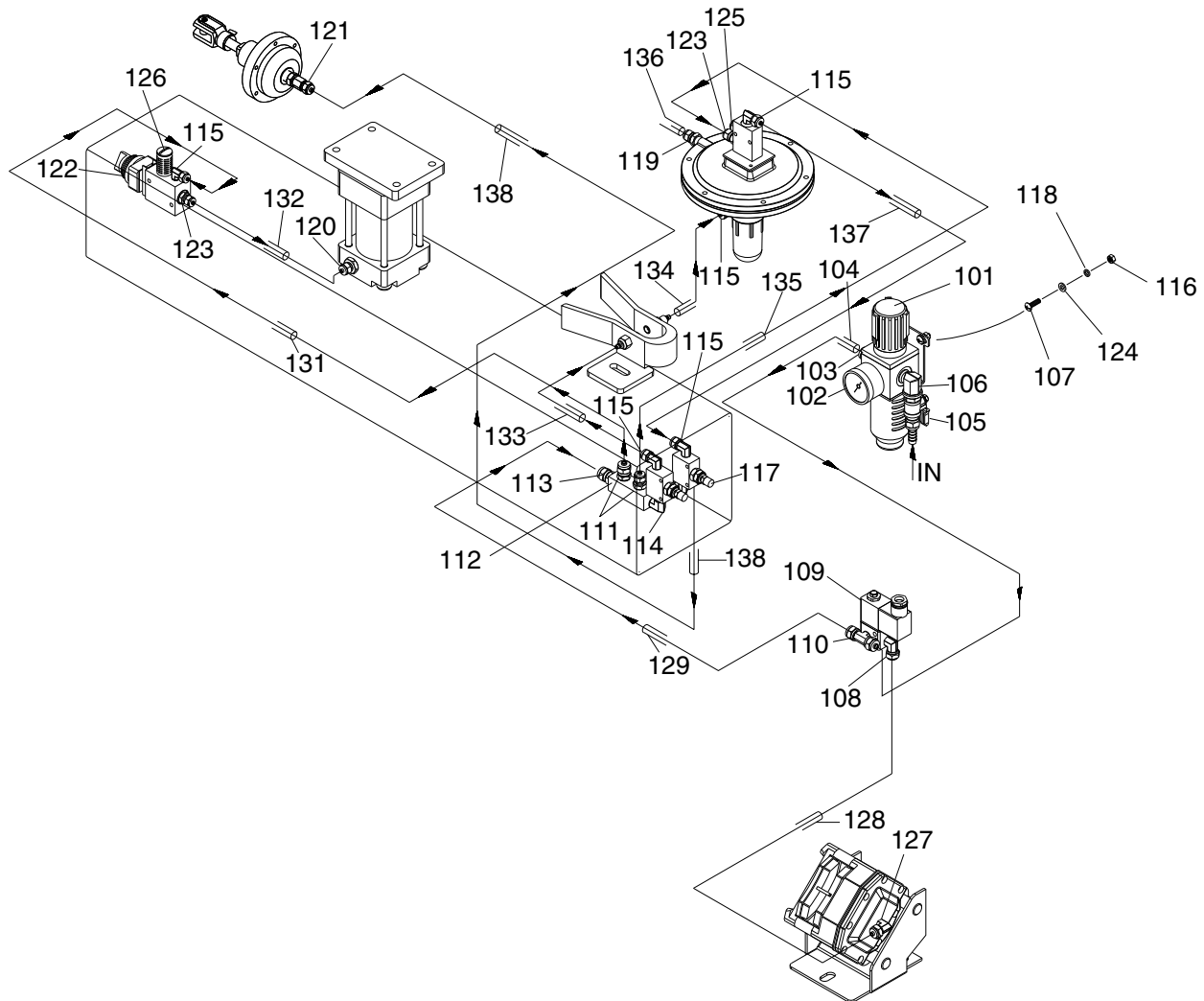

REF	PART #	DESCRIPTION
101	PH29339101	REGULATOR ASSEMBLY
102	PH29339102	PRESSURE GAUGE
103	PH29339103	BRONZE CONNECTOR 5/16N X 1/4T
104	PH29339104	FLEXIBLE HOSE
105	PH29339105	AIR SWITCH 1/4"
106	PH29339106	ELBOW
107	PS22	PHLP HD SCR 10-24 X 5/8
108	PH29339108	ELBOW 5/16N X 1/8T 90 DEG
109	PH29339109	SOLENOID VALVE
110	PH29339110	T-FITTING 5/16N X 1/8T X 5/16N
111	PH29339111	CONNECTOR 1/4N X 1/4T
112	P9962Z9112	MANIFOLD 1/4T
113	PH29339113	CONNECTOR 5/16N X 1/4T
114	P06779114	ELBOW 1/4T X 1/8T 90 DEG
115	PH29339115	CONNECTOR 1/4N X 1/8T 90 DEG
116	PN07	HEX NUT 10-24
117	PH29339117	THROTTLE VALVE 1/8"
118	PLW03	LOCK WASHER 10-24
119	PH29339119	CONNECTOR 1/4N X 1/4T - 90 DEG

REF	PART #	DESCRIPTION
120	PH29339120	CONNECTOR 1/4N X 3/8T
121	PH29339121	CONNECTOR 1/4N X 1/8T
122	PH29339122	AIR SWITCH 1/8"
123	PH29339123	CONNECTOR 1/4N X 1/8T
124	PW03	FLAT WASHER #10
125	PH29339125	BUFFER 1/8"
126	PH29339126	BUFFER 1/8"
127	PH29339127	CONNECTOR 5/16N X 1/8T 90 DEG
128	PH29339128	FLEXIBLE HOSE 8MM
129	PH29339129	FLEXIBLE HOSE 8MM
131	PH29339131	FLEXIBLE HOSE 6MM
132	PH29339132	FLEXIBLE HOSE 6MM
133	PH29339133	FLEXIBLE HOSE 6MM
134	PH29339134	FLEXIBLE HOSE 6MM
135	PH29339135	FLEXIBLE HOSE 6MM
136	PH29339136	FLEXIBLE HOSE 6MM
137	PH29339137	FLEXIBLE HOSE 6MM
138	PH29339138	FLEXIBLE HOSE 6MM

Labels and Cosmetic Parts Breakdown 9000 Series Parts

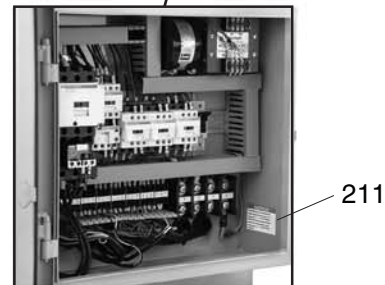
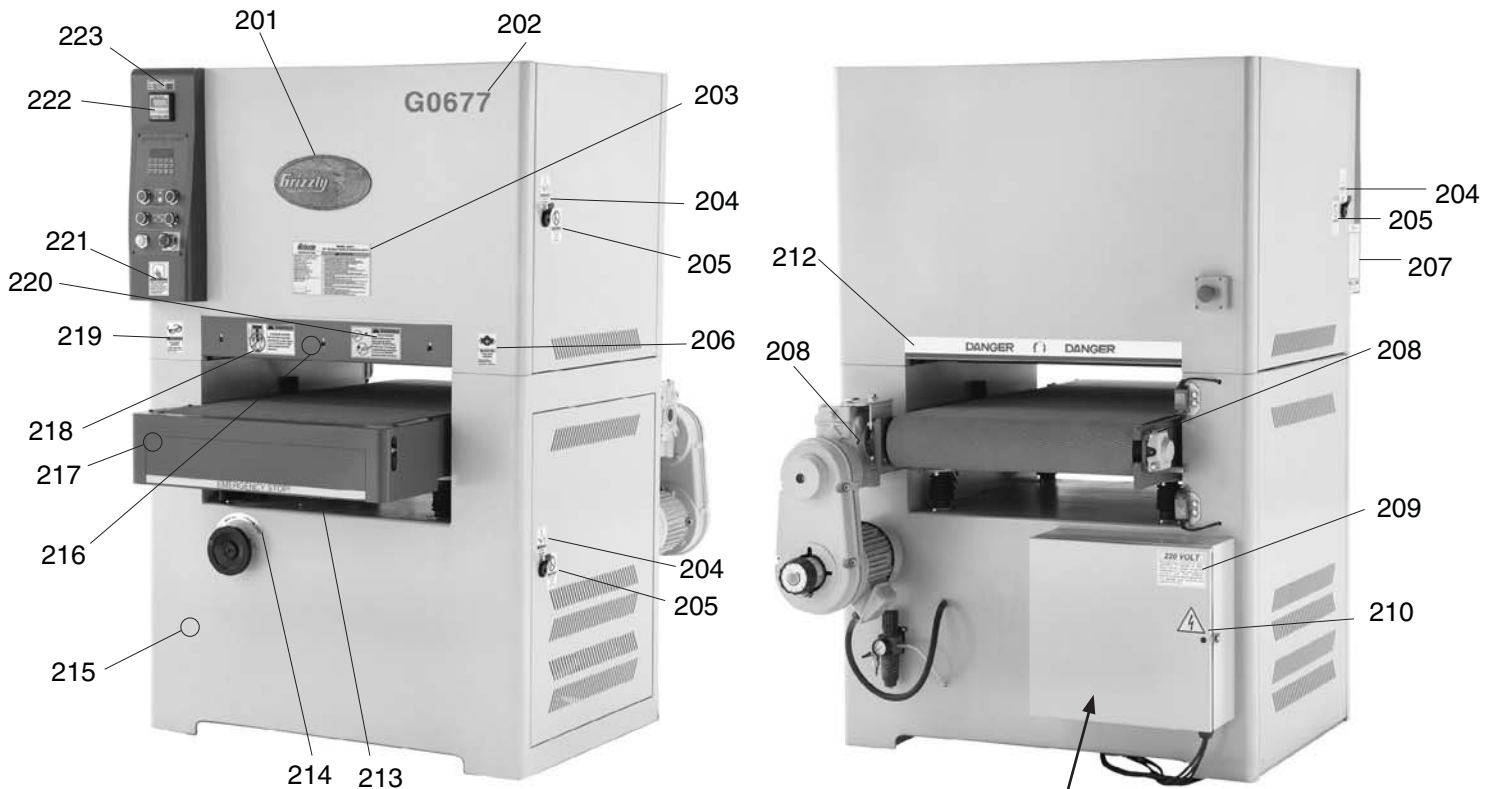

REF	PART #	DESCRIPTION
201	G8589	LARGE GRIZZLY NAMEPLATE
202	P06779202	MODEL G0677 LABEL
203	P06779203	MACHINE ID LABEL
204	PLABEL-13	DISCONNECT SANDER 220V
205	PLABEL-30	DOOR CLOSED LABEL
206	PLABEL-61A	RESPIRATOR LABEL
207	PLABEL-27	MM CONVERSION CHART
208	P06779208	GREASE FITTING LUBRICATION
209	PLABEL-34C	PREWIRED 220V LABEL
210	PLABEL-14	ELECTRICITY LABEL
211	P06779211	PHASE CONVERTER NOTICE
212	P06779212	DANGER STRIP
213	P06779213	EMERGENCY STOP STRIPE
214	P06779214	ROTATION LABEL
215	PPAINT-11	GREY PUTTY TOUCH UP PAINT
216	PPAINT-16	RED TOUCH UP PAINT

REF	PART #	DESCRIPTION
217	PPAINT-1	GRIZZLY GREEN TOUCH UP PAINT
218	P06779218	KICKBACK HAZARD LABEL
219	PLABEL-11	SAFETY GLASSES LABEL
220	P06779220	PINCH HAZARD LABEL
221	PLABEL-12A	READ MANUAL LABEL
222	P06779222	LOAD METER FACE LABEL
223	P06779223	AMP LOAD CHART

WARNING

Safety labels warn about machine hazards and ways to prevent injury. The owner of this machine **MUST** maintain the original location and readability of the labels on the machine. If any label is removed or becomes unreadable, **REPLACE** that label before using the machine again. Contact Grizzly at (800) 523-4777 or www.grizzly.com to order new labels.





WARRANTY CARD

Name _____

Street _____

City _____ State _____ Zip _____

Phone # _____ Email _____ Invoice # _____

Model # _____ Order # _____ Serial # _____

The following information is given on a voluntary basis. It will be used for marketing purposes to help us develop better products and services. **Of course, all information is strictly confidential.**

1. How did you learn about us?

- Advertisement
- Card Deck
- Friend
- Website
- Catalog
- Other:

2. Which of the following magazines do you subscribe to?

- | | | |
|---|--|---|
| <input type="checkbox"/> Cabinet Maker | <input type="checkbox"/> Popular Mechanics | <input type="checkbox"/> Today's Homeowner |
| <input type="checkbox"/> Family Handyman | <input type="checkbox"/> Popular Science | <input type="checkbox"/> Wood |
| <input type="checkbox"/> Hand Loader | <input type="checkbox"/> Popular Woodworking | <input type="checkbox"/> Wooden Boat |
| <input type="checkbox"/> Handy | <input type="checkbox"/> Practical Homeowner | <input type="checkbox"/> Woodshop News |
| <input type="checkbox"/> Home Shop Machinist | <input type="checkbox"/> Precision Shooter | <input type="checkbox"/> Woodsmith |
| <input type="checkbox"/> Journal of Light Cont. | <input type="checkbox"/> Projects in Metal | <input type="checkbox"/> Woodwork |
| <input type="checkbox"/> Live Steam | <input type="checkbox"/> RC Modeler | <input type="checkbox"/> Woodworker West |
| <input type="checkbox"/> Model Airplane News | <input type="checkbox"/> Rifle | <input type="checkbox"/> Woodworker's Journal |
| <input type="checkbox"/> Modeltec | <input type="checkbox"/> Shop Notes | <input type="checkbox"/> Other: |
| <input type="checkbox"/> Old House Journal | <input type="checkbox"/> Shotgun News | |

3. What is your annual household income?

- \$20,000-\$29,000
- \$30,000-\$39,000
- \$40,000-\$49,000
- \$50,000-\$59,000
- \$60,000-\$69,000
- \$70,000+

4. What is your age group?

- 20-29
- 30-39
- 40-49
- 50-59
- 60-69
- 70+

5. How long have you been a woodworker/metalworker?

- 0-2 Years
- 2-8 Years
- 8-20 Years
- 20+ Years

6. How many of your machines or tools are Grizzly?

- 0-2
- 3-5
- 6-9
- 10+

7. Do you think your machine represents a good value? Yes No

8. Would you recommend Grizzly Industrial to a friend? Yes No

9. Would you allow us to use your name as a reference for Grizzly customers in your area?
Note: We never use names more than 3 times. Yes No

10. Comments: _____

CUT ALONG DOTTED LINE

FOLD ALONG DOTTED LINE



Place
Stamp
Here



GRIZZLY INDUSTRIAL, INC.
P.O. BOX 2069
BELLINGHAM, WA 98227-2069



FOLD ALONG DOTTED LINE

Send a Grizzly Catalog to a friend:

Name _____
Street _____
City _____ State _____ Zip _____

TAPE ALONG EDGES--PLEASE DO NOT STAPLE

WARRANTY AND RETURNS

Grizzly Industrial, Inc. warrants every product it sells for a period of **1 year** to the original purchaser from the date of purchase. This warranty does not apply to defects due directly or indirectly to misuse, abuse, negligence, accidents, repairs or alterations or lack of maintenance. This is Grizzly's sole written warranty and any and all warranties that may be implied by law, including any merchantability or fitness, for any particular purpose, are hereby limited to the duration of this written warranty. We do not warrant or represent that the merchandise complies with the provisions of any law or acts unless the manufacturer so warrants. In no event shall Grizzly's liability under this warranty exceed the purchase price paid for the product and any legal actions brought against Grizzly shall be tried in the State of Washington, County of Whatcom.

We shall in no event be liable for death, injuries to persons or property or for incidental, contingent, special, or consequential damages arising from the use of our products.

To take advantage of this warranty, contact us by mail or phone and give us all the details. We will then issue you a "Return Number," which must be clearly posted on the outside as well as the inside of the carton. We will not accept any item back without this number. Proof of purchase must accompany the merchandise.

The manufacturers reserve the right to change specifications at any time because they constantly strive to achieve better quality equipment. We make every effort to ensure that our products meet high quality and durability standards and we hope you never need to use this warranty.

Please feel free to write or call us if you have any questions about the machine or the manual.

Thank you again for your business and continued support. We hope to serve you again soon.

grizzly.com

TOOL WEBSITE

Buy Direct and Save with Grizzly® – Trusted, Proven and a Great Value!

*Visit Our Website Today And Discover
Why Grizzly® Is The Industry Leader!*

- SECURE ORDERING
- ORDERS SHIPPED WITHIN 24 HOURS
- E-MAIL RESPONSE WITHIN ONE HOUR

-OR-

Call Today For A **FREE**
Full Color Catalog

1-800-523-4777



Free Manuals Download Website

<http://myh66.com>

<http://usermanuals.us>

<http://www.somanuals.com>

<http://www.4manuals.cc>

<http://www.manual-lib.com>

<http://www.404manual.com>

<http://www.luxmanual.com>

<http://aubethermostatmanual.com>

Golf course search by state

<http://golfingnear.com>

Email search by domain

<http://emailbydomain.com>

Auto manuals search

<http://auto.somanuals.com>

TV manuals search

<http://tv.somanuals.com>