

Parts Breakdown

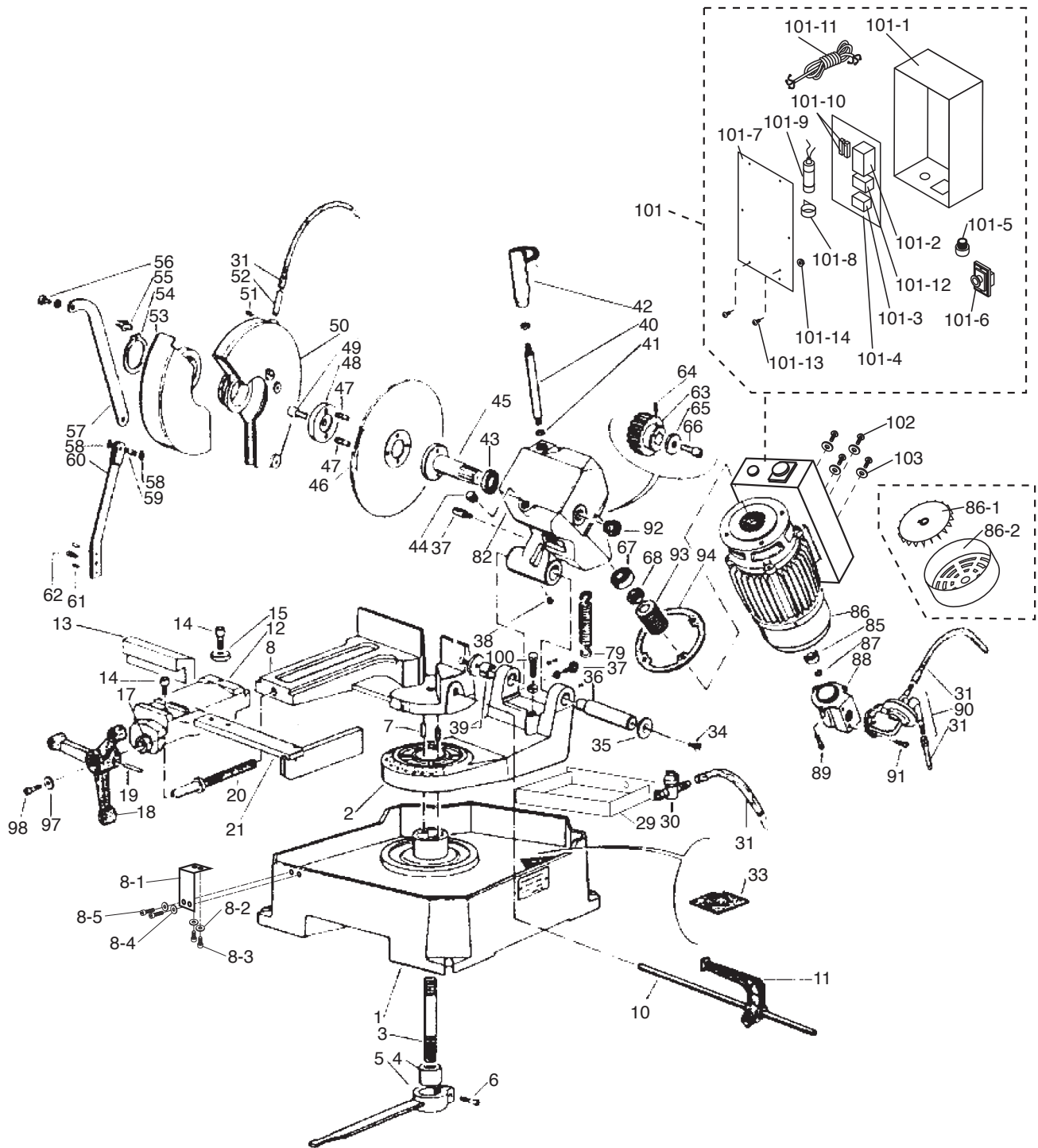

Parts List

REF	PART #	DESCRIPTION
1	P0665001	MACHINE BED
2	P0665002	REVOLVING ARM
3	P0665003	LOCK PIN
4	P0665004	BUSHING
5	P0665005	LEVER
6	PSB13M	CAP SCREW M8-1.25 X 30
7	P0665007	BASE PIN
8	P0665008	WISE BASE
8-1	P0665008-1	SUPPORT PLATE
8-2	PW02M	FLAT WASHER 5MM
8-3	PSB33M	CAP SCREW M5-.8 X 12
8-4	PW03M	FLAT WASHER 6MM
8-5	PSB04M	CAP SCREW M6-1 X 10
10	P0665010	WORK STOP ROD
11	P0665011	WORK STOP
12	P0665012	WISE
13	P0665013	WISE JAW
14	PSB36M	CAP SCREW M12-1.75 X 25
15	P0665015	CLAMP WASHER
17	P0665017	OILER
18	P0665018	WISE HANDWHEEL
19	PRP32M	ROLL PIN 6 X 40
20	P0665020	LEADSCREW
21	P0665021	AUXILIARY STABILIZING BRACKET
29	P0665029	COOLANT TRAY
30	P0665030	COOLANT VALVE
31	P0665031	COOLANT TUBE
33	P0665033	TANK FILTER
34	P0665034	FLAT HD SCR M8-1.25 X 20
35	P0665035	SPECIAL NUT
36	P0665036	HINGE PIN
37	P0665037	SPRING HOOK SCREW
38	PSB31M	CAP SCREW M8-1.25 X 25
39	P0665039	HINGE BUSHING
40	P0665040	HEAD LEVER
41	PN13M	HEX NUT M16-2
42	P0665042	HEAD LEVER HANDGRIP
43	P0665043	RING
44	P0665044	PLUG
45	P0665045	BLADE SHAFT
46	P0665046	BLADE
47	P0665047	BLADE FLANGE PIN SCREW
48	P0665048	BLADE FLANGE
49	PSB77M	CAP SCREW M12-1.75 X 30
50	P0665050	FIXED GUARD
51	PSB28M	CAP SCREW M6-1 X 15
52	P0665052	COOLANT TUBE
53	P0665053	MOBILE GUARD
54	PR71M	EXT RETAINING RING 60MM

REF	PART #	DESCRIPTION
55	PSB06M	CAP SCREW M6-1 X 25
56	PSB04M	CAP SCREW M6-1 X 10
57	P0665057	MOBILE GUARD ROD
58	PSB14M	CAP SCREW M8-1.25 X 20
59	PLN04M	LOCK NUT M8-1.25
60	P0665060	TIE ROD SUPPORT
61	PRP03M	ROLL PIN 5 X 20
62	PSB11M	CAP SCREW M8-1.25 X 16
63	P0665063	PINION GEAR
64	PSS20M	SET SCREW M8-1.25 X 8
65	P0665065	PINION GEAR RETAINING WASHER
66	P0665066	SPECIAL SCREW M12-1.75 X 25
67	P0665067	BALL BEARING 6301ZZ
68	P0665068	SPECIAL NUT M16
79	P0665079	HEAD RETURN TENSION SPRING
82	P0665082	GEARBOX CASE
85	P0665085	BALL BEARING 609
86	P0665086	MOTOR 1-1/4HP 220V SINGLE PHASE
86-1	P0665086-1	MOTOR FAN
86-2	P0665086-2	MOTOR FAN COVER
87	PR16M	EXT RETAINING RING 9MM
88	P0665088	PUMP CONNECTION BOX
89	PSB16M	CAP SCREW M4-.7 X 16
90	P0665090	COOLANT PUMP
91	PSB02M	CAP SCREW M6-1 X 20
92	P0665092	OIL LEVEL DRAIN PLUG
93	P0665093	WORM SCREW
94	P0665094	HEAD GASKET
97	PW01M	FLAT WASHER 8MM
98	PSB14M	CAP SCREW M8-1.25 X 20
100	PB01M	HEX BOLT M10-1.5 X 30
101	P0665101	CONTROL BOX
101-1	P0665101-1	CASE
101-2	P0665101-2	MAGNETIC SWITCH TC-11
101-3	P0665101-3	TRANSFORMER 250V
101-4	P0665101-4	BACKING PLATE
101-5	P0665101-5	INDICATOR LIGHT
101-6	P0665101-6	ON/OFF SWITCH
101-7	P0665101-7	COVER
101-8	P0665101-8	CAPACITOR STRAP
101-9	P0665101-9	R CAPACITOR 30M 350V 1-5/8 X 3-3/8
101-10	P0665101-10	FUSE
101-11	P0665101-11	POWER CORD
101-12	P0665101-12	OVERLOAD RELAY TEND THR12
101-13	PS17M	PHLP HD SCR M4-.7 X 6
101-14	PN04M	HEX NUT M4-.7
102	PS08M	PHLP HD SCR M5-.8 X 12
103	PW02M	FLAT WASHER 5MM



Stand Breakdown

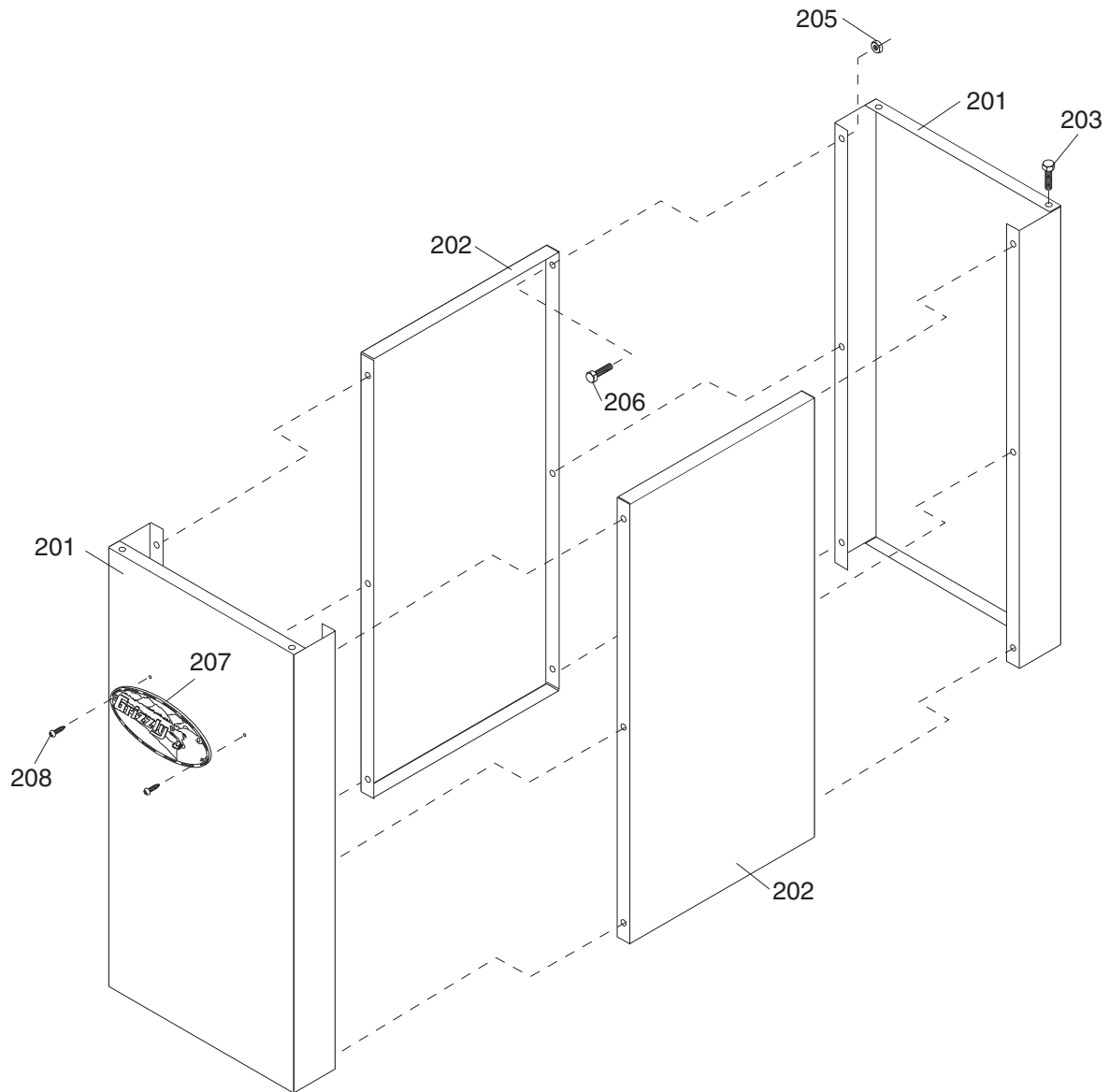

REF	PART #	DESCRIPTION
201	P0665201	END PANEL
202	P0665202	SIDE PANEL
203	PB20M	HEX BOLT M8-1.25 X 35
205	PN03M	HEX NUT M8-1.25

REF	PART #	DESCRIPTION
206	PB09M	HEX BOLT M8-1.25 X 20
207	G8589	GRIZZLY NAMEPLATE-LARGE
208	PHTEK24	TAP SCREW #5 X 3/8



Warning Labels

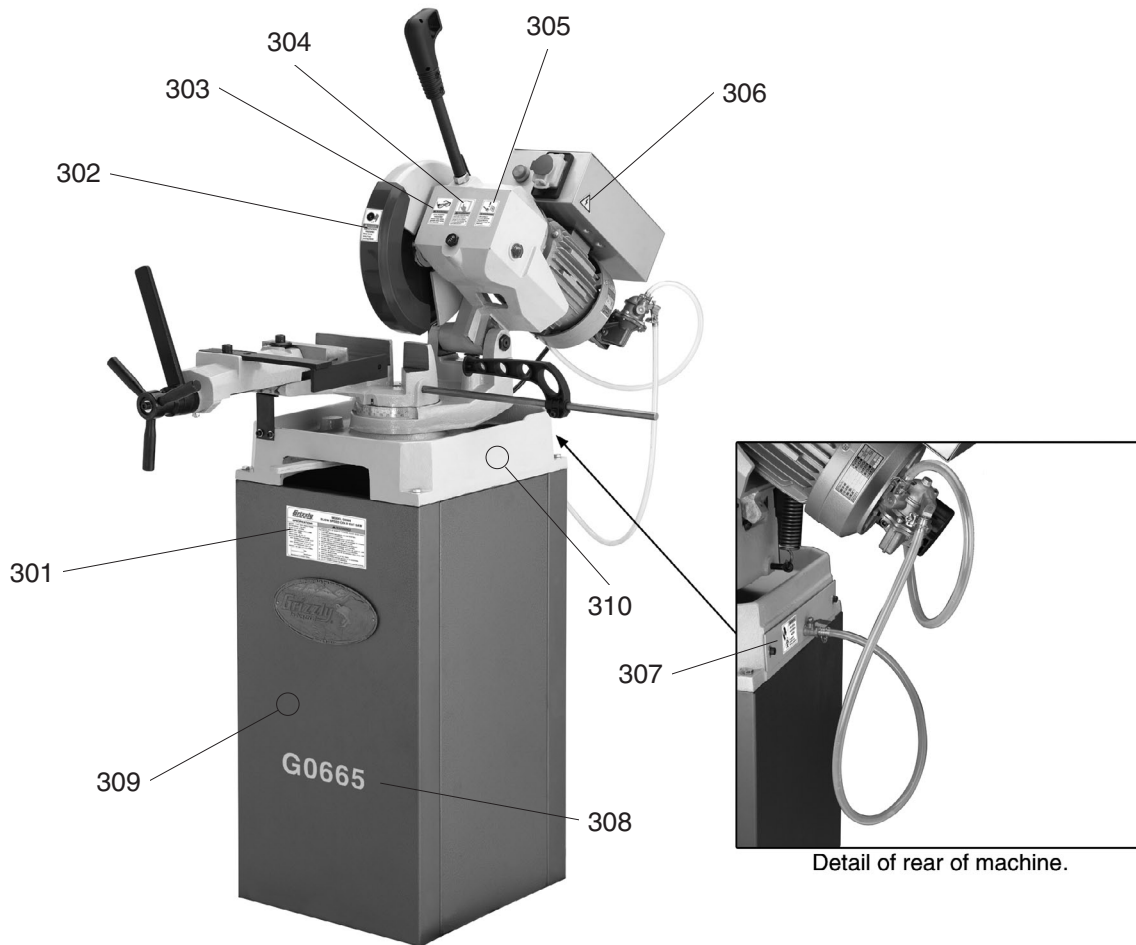

Detail of rear of machine.

REF	PART #	DESCRIPTION
301	P0665301	MACHINE ID LABEL
302	P0665302	AMPUTATION HAZARD LABEL
303	P0665303	EYE INJURY LABEL
304	P0665304	READ MANUAL LABEL
305	P0665305	DISCONNECT POWER LABEL

REF	PART #	DESCRIPTION
306	PLABEL-14	ELECTRICITY LABEL
307	P0665307	CUTTING FLUID LABEL
308	P0665308	MODEL NUMBER LABEL
309	PPAINT-1	GRIZZLY GREEN TOUCH UP PAINT
310	PPAINT-11	GRIZZLY PUTTY TOUCH UP PAINT

⚠️ WARNING

Safety labels warn about machine hazards and ways to prevent injury. The owner of this machine **MUST** maintain the original location and readability of the labels on the machine. If any label is removed or becomes unreadable, **REPLACE** that label before using the machine again. Contact Grizzly at (800) 523-4777 or www.grizzly.com to order new labels.



Free Manuals Download Website

<http://myh66.com>

<http://usermanuals.us>

<http://www.somanuals.com>

<http://www.4manuals.cc>

<http://www.manual-lib.com>

<http://www.404manual.com>

<http://www.luxmanual.com>

<http://aubethermostatmanual.com>

Golf course search by state

<http://golfingnear.com>

Email search by domain

<http://emailbydomain.com>

Auto manuals search

<http://auto.somanuals.com>

TV manuals search

<http://tv.somanuals.com>