

# **Grizzly** **Industrial, Inc.**®

## **MODEL G0771** **10" HYBRID TABLE SAW** **OWNER'S MANUAL** *(For models manufactured since 8/15)*



COPYRIGHT © OCTOBER, 2014 BY GRIZZLY INDUSTRIAL, INC. REVISED AUGUST, 2015 (MN)  
**WARNING: NO PORTION OF THIS MANUAL MAY BE REPRODUCED IN ANY SHAPE  
OR FORM WITHOUT THE WRITTEN APPROVAL OF GRIZZLY INDUSTRIAL, INC.**  
#WK16774 PRINTED IN CHINA

V2.08.15

 **WARNING!**

**This manual provides critical safety instructions on the proper setup, operation, maintenance, and service of this machine/tool. Save this document, refer to it often, and use it to instruct other operators.**

**Failure to read, understand and follow the instructions in this manual may result in fire or serious personal injury—including amputation, electrocution, or death.**

**The owner of this machine/tool is solely responsible for its safe use. This responsibility includes but is not limited to proper installation in a safe environment, personnel training and usage authorization, proper inspection and maintenance, manual availability and comprehension, application of safety devices, cutting/sanding/grinding tool integrity, and the usage of personal protective equipment.**

**The manufacturer will not be held liable for injury or property damage from negligence, improper training, machine modifications or misuse.**

 **WARNING!**

**Some dust created by power sanding, sawing, grinding, drilling, and other construction activities contains chemicals known to the State of California to cause cancer, birth defects or other reproductive harm. Some examples of these chemicals are:**

- **Lead from lead-based paints.**
- **Crystalline silica from bricks, cement and other masonry products.**
- **Arsenic and chromium from chemically-treated lumber.**

**Your risk from these exposures varies, depending on how often you do this type of work. To reduce your exposure to these chemicals: Work in a well ventilated area, and work with approved safety equipment, such as those dust masks that are specially designed to filter out microscopic particles.**

# Table of Contents

<b>INTRODUCTION</b> .....	<b>2</b>	<b>SECTION 5: SHOP MADE SAFETY</b>	
Machine Description .....	2	<b>ACCESSORIES</b> .....	<b>45</b>
Contact Info.....	2	Featherboards.....	45
Manual Accuracy .....	2	Push Sticks .....	48
Identification.....	3	Push Blocks .....	49
Controls & Components.....	4	Narrow-Rip Auxiliary Fence & Push Block ..	50
Glossary of Terms .....	5	Outfeed & Support Tables .....	52
Machine Data Sheet .....	6	Crosscut Sled.....	52
<b>SECTION 1: SAFETY</b> .....	<b>8</b>	<b>SECTION 6: ACCESSORIES</b> .....	<b>53</b>
Safety Instructions for Machinery .....	8	<b>SECTION 7: MAINTENANCE</b> .....	<b>55</b>
Additional Safety for Table Saws.....	10	Schedule .....	55
Preventing Kickback .....	11	Cleaning & Protecting .....	55
Protecting Yourself From Kickback.....	11	Lubrication .....	56
<b>SECTION 2: POWER SUPPLY</b> .....	<b>12</b>	<b>SECTION 8: SERVICE</b> .....	<b>57</b>
Converting Voltage to 240V.....	14	Troubleshooting .....	57
<b>SECTION 3: SETUP</b> .....	<b>15</b>	Blade Tilt Calibration.....	59
Needed for Setup.....	15	Miter Slot to Blade Parallelism.....	61
Unpacking .....	15	Spreader or Riving Knife Alignment .....	63
Inventory .....	16	Calibrating Fence to Blade .....	65
Cleanup.....	17	Fence Scale Calibration.....	66
Site Considerations.....	18	Table/Dado Insert Adjustment .....	66
Assembly .....	19	Miter Gauge Adjustments .....	67
Dust Collection.....	24	Belt Tension & Replacement .....	68
Test Run .....	24	<b>SECTION 9: WIRING</b> .....	<b>69</b>
Recommended Adjustments.....	25	Wiring Safety Instructions .....	69
<b>SECTION 4: OPERATIONS</b> .....	<b>26</b>	Wiring Diagram .....	70
Operation Overview .....	26	Electrical Components.....	71
Workpiece Inspection.....	27	<b>SECTION 10: PARTS</b> .....	<b>72</b>
Non-Through & Through Cuts .....	27	Main .....	72
Blade Requirements .....	28	Cabinet.....	74
Blade Selection .....	28	Fence & Rails .....	75
Blade Installation.....	29	Blade Guard.....	76
Blade Guard Assembly .....	30	Miter Gauge .....	77
Riving Knife.....	33	Labels & Cosmetics .....	78
Ripping.....	34	<b>WARRANTY &amp; RETURNS</b> .....	<b>81</b>
Crosscutting .....	35		
Miter Cuts.....	36		
Blade Tilt/Bevel Cuts .....	36		
Dado Cutting .....	36		
Rabbet Cutting.....	39		
Resawing .....	41		

# INTRODUCTION

## Machine Description

This hybrid table saw features a powerful 2 HP motor, steel cabinet-type stand with a 4" dust port, cast iron trunnions, and a precision-ground cast iron table with extension wings.

Includes an easy-glide fence, miter gauge, quick-release spreader/blade guard assembly, and a 10" x 40T saw blade.

## Contact Info

We stand behind our machines! If you have questions or need help, contact us with the information below. Before contacting, make sure you get the **serial number** and **manufacture date** from the machine ID label. This will help us help you faster.

Grizzly Technical Support  
1815 W. Battlefield  
Springfield, MO 65807  
Phone: (570) 546-9663  
Email: techsupport@grizzly.com

We want your feedback on this manual. What did you like about it? Where could it be improved? Please take a few minutes to give us feedback.

Grizzly Documentation Manager  
P.O. Box 2069  
Bellingham, WA 98227-2069  
Email: manuals@grizzly.com

## Manual Accuracy

We are proud to provide a high-quality owner's manual with your new machine!

We made every effort to be exact with the instructions, specifications, drawings, and photographs in this manual. Sometimes we make mistakes, but our policy of continuous improvement also means that **sometimes the machine you receive is slightly different than shown in the manual.**

If you find this to be the case, and the difference between the manual and machine leaves you confused or unsure about something, check our website for an updated version. We post current manuals and manual updates for free on our website at **www.grizzly.com**.

Alternatively, you can call our Technical Support for help. Before calling, make sure you write down the **Manufacture Date** and **Serial Number** from the machine ID label (see below). This information is required for us to provide proper tech support, and it helps us determine if updated documentation is available for your machine.

		<b>MODEL GXXXX</b>	
		<b>MACHINE NAME</b>	
<b>SPECIFICATIONS</b>		<b>▲ WARNING!</b>	
Motor:		To reduce risk of serious injury when using this machine:	
Specification:		1. Read manual before operation.	
Specification:		2. Wear safety glasses and respirator.	
Specification:		3. Make sure safety is correctly adjusted/setup and	
Specification:		4. power is connected to grounded circuit before starting.	
Weight:		5. Make sure the motor has stopped and disconnect	
		6. power before adjustments, maintenance, or service.	
		7. DO NOT expose to rain or dampness.	
		8. DO NOT modify this machine in any way.	
		9. power is disconnected.	
		10. Avoid use of drugs or alcohol.	
		10. Maintain machine carefully to prevent accidents.	
		Manufactured for Grizzly in Taiwan	

Manufacture Date

Serial Number



# Identification

Become familiar with the names and locations of the controls and features shown below to better understand the instructions in this manual.

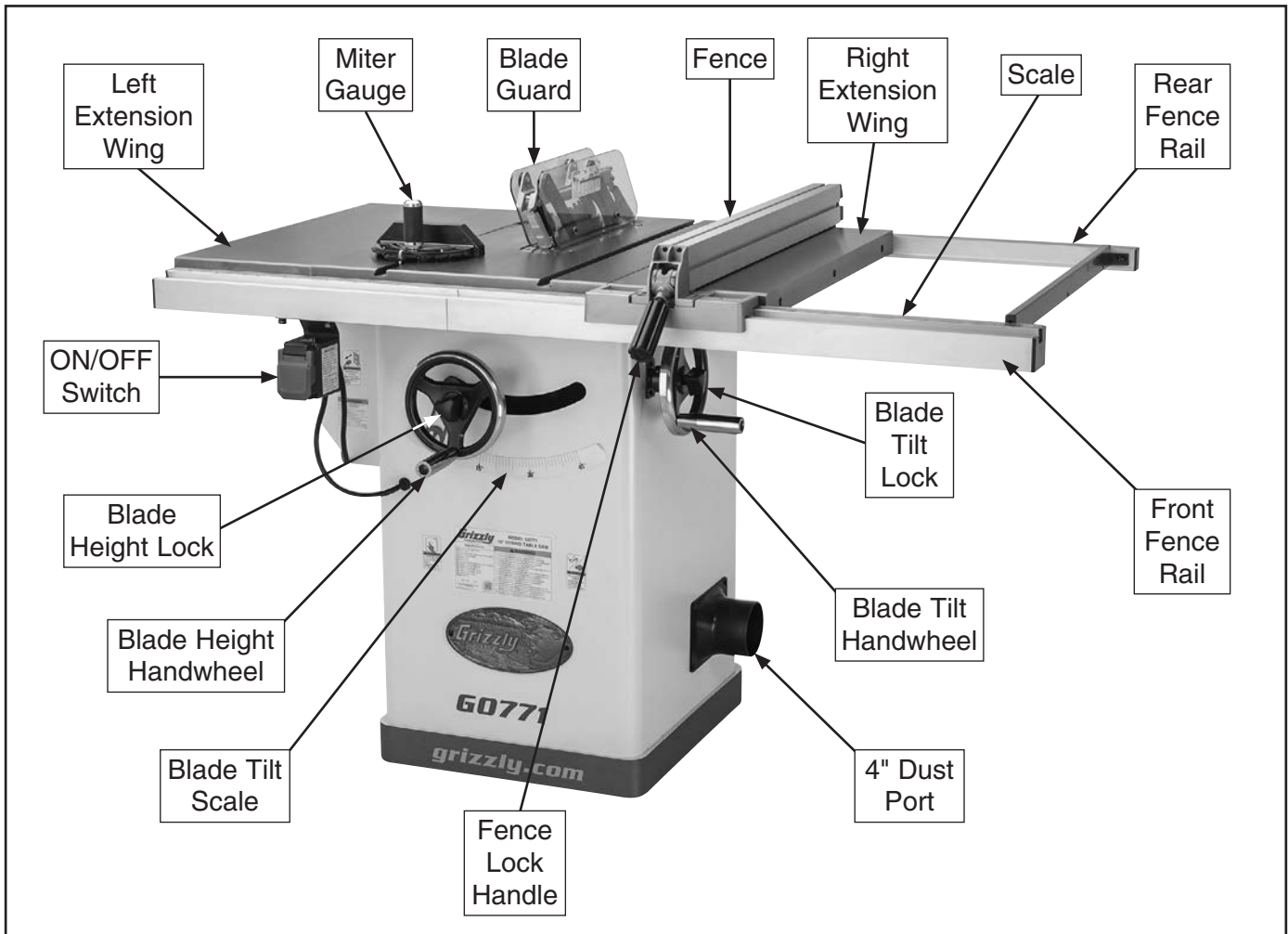

**Figure 1.** Model G0771 identification of main controls and components.

## **⚠ CAUTION**

**For Your Own Safety Read Instruction Manual Before Operating Saw**

- a) Wear eye protection.
- b) Use saw-blade guard and spreader for every operation for which it can be used, including all through sawing.
- c) Keep hands out of the line of saw blade.
- d) Use a push-stick when required.
- e) Pay particular attention to instructions on reducing risk of kickback.
- f) Do not perform any operation freehand.
- g) Never reach around or over saw blade.



# Controls & Components



Refer to **Figures 2–4** and the following descriptions to become familiar with the basic controls of this machine.

- A. ON/OFF Switch:** Starts and stops the motor. The switch can be disabled for safety by removing the key.

**Note:** *Paddle cover must be lifted to access ON switch.*



**Figure 2.** ON/OFF switch.

- B. Blade Height Handwheel:** Adjusts blade height from 0"–3¼".
- C. Blade Tilt Handwheel:** Adjusts angle of blade tilt from 90°–45°.
- D. Handwheel Locks:** Lock blade height and angle when tightened (one on each handwheel).

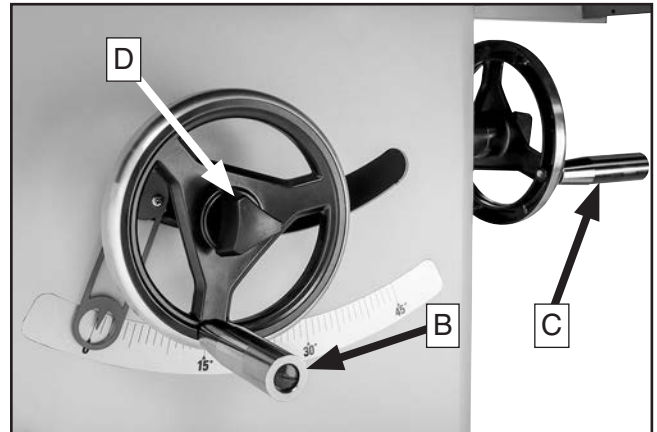

**Figure 3.** Blade adjustment handwheels and locks.

- E. Fence Lock:** Locks fence when pushed down, unlocks fence when pulled up.



**Figure 4.** Fence lock handle.



# Glossary of Terms

---

The following is a list of common definitions, terms and phrases used throughout this manual as they relate to this table saw and woodworking in general. Become familiar with these terms for assembling, adjusting or operating this machine. Your safety is **VERY** important to us at Grizzly!

**Arbor:** Rotating metal shaft to which saw blade is mounted that extends from the drive mechanism.

**Bevel Edge Cut:** Tilting the arbor and saw blade to an angle between 0° and 45° to cut a beveled edge onto a workpiece.

**Blade Guard:** Metal or plastic safety device that mounts over the saw blade. Its function is to prevent the operator from coming into contact with the saw blade.

**Crosscut:** Cutting operation in which the fence is used to cut across the grain, or the miter gauge is used to cut across the shortest width of the workpiece.

**Dado Blade:** Blade or set of blades that are used to cut wide grooves and rabbets.

**Dado Cut:** "Non-through" cutting operation that uses a dado blade to cut a flat-bottomed groove into the face of the workpiece.

**Featherboard:** Safety device used to keep the workpiece against the rip fence and table surface.

**Kerf:** The resulting cut or gap in the workpiece after the saw blade passes through during a cutting operation.

**Kickback:** An event in which the workpiece is propelled back towards the operator at a high rate of speed.

**Parallel:** Being an equal distance apart at every point along two given lines or planes. I.e. the rip fence face is parallel to the face of the saw blade.

**Non-Through Cut:** A cut in which the blade does not cut through the top of the workpiece. Refer to **Page 27** for more details.

**Perpendicular:** Lines or planes that intersect and form right angles. I.e. the blade is perpendicular to the table surface.

**Push Stick:** Safety device used to push the workpiece through a cutting operation. Used most often when rip cutting thin workpieces.

**Rabbet:** Cutting operation that creates an L-shaped channel along the edge of the workpiece.

**Riving Knife:** Metal plate located behind the blade. It maintains the kerf opening in the wood when performing a cutting operation. Refer to **Page 33** for more details.

**Straightedge:** A tool used to check the flatness, parallelism, or consistency of a surface(s).

**Through Cut:** A sawing operation in which the workpiece is completely sawn through.

**Rip Cut:** Cutting operation in which the rip fence is used to cut with the grain, or across the widest width of the workpiece.





# MACHINE DATA SHEET

Customer Service #: (570) 546-9663 · To Order Call: (800) 523-4777 · Fax #: (800) 438-5901

## MODEL G0771 10" HYBRID TABLE SAW

### Product Dimensions:

Weight..... 286 lbs.  
 Width (side-to-side) x Depth (front-to-back) x Height..... 57-1/4 x 37-1/2 x 35-3/8 in.  
 Footprint (Length x Width)..... 21 x 19-1/2 in.

### Shipping Dimensions:

#### Carton #1

Type..... Cardboard Box on Wood Skids  
 Content..... Machine  
 Weight..... 330 lbs.  
 Length x Width x Height..... 30 x 26 x 44 in.

#### Carton #2

Type..... Cardboard Box  
 Content..... Fence  
 Weight..... 18 lbs.  
 Length x Width x Height..... 38-1/2 x 10-1/2 x 5-1/2 in.

### Electrical:

Power Requirement..... 120V or 240V, Single-Phase, 60 Hz  
 Prewired Voltage..... 120V  
 Full-Load Current Rating..... 15A at 120V, 7.5A at 240V  
 Minimum Circuit Size..... 20A at 120V, 15A at 240V  
 Connection Type..... Cord and Plug  
 Power Cord Included..... Yes  
 Power Cord Length..... 6 ft.  
 Power Cord Gauge..... 14 AWG  
 Plug Included..... Yes  
 Included Plug Type..... 5-15 for 120V  
 Switch Type..... Toggle ON/OFF Switch with Stop Plate

### Motors:

#### Main

Type..... TEFC Capacitor-Start Induction  
 Horsepower..... 2 HP  
 Phase..... Single-Phase  
 Amps..... 15A/7.5A  
 Speed..... 3450 RPM  
 Power Transfer..... Belt Drive  
 Bearings..... Sealed & Permanently Lubricated





## Main Specifications:

### Main Information

Table Saw Type.....	Hybrid
Maximum Blade Diameter.....	10 in.
Arbor Size.....	5/8 in.
Arbor Speed.....	3450 RPM
Maximum Width of Dado.....	13/16 in.
Blade Tilt Direction.....	Left
Max Blade Tilt.....	45 deg.
Maximum Depth of Cut At 90 Degrees.....	3-1/4 in.
Maximum Depth of Cut At 45 Degrees.....	2-1/4 in.
Max Rip Right of Blade w/Included Fence & Rails.....	30 in.
Max Rip Left of Blade w/Included Fence & Rails.....	15 in.

### Additional Blade Information

Included Blade Information.....	10" x 40T
Riving Knife/Spreader Thickness.....	0.090 in.
Required Blade Body Thickness.....	0.060 – 0.086 in.
Required Blade Kerf Thickness.....	0.094 – 0.126 in.
Rim Speed at Max Blade Diameter.....	9025 FPM

### Table Information

Floor to Table Height.....	35-3/8 in.
Table Size with Extension Wings Width.....	40-1/2 in.
Table Size with Extension Wings Depth.....	27 in.
Distance Front of Table to Center of Blade.....	15-1/2 in.
Distance Front of Table to Blade At Maximum Cut.....	11-1/2 in.
Main Table Size Thickness.....	1-5/8 in.

### Fence Information

Fence Type.....	Camlock T-Shape w/Aluminum Face
Fence Size Length.....	29-3/4 in.
Fence Size Width.....	2 in.
Fence Size Height.....	2-3/4 in.
Fence Rail Type.....	Extruded Aluminum
Fence Rail Length.....	56-3/4 in.
Fence Rail Width.....	2-3/4 in.
Fence Rail Height.....	2-1/4 in.

### Miter Gauge Information

Miter Gauge Slot Type.....	T-Slot
Miter Gauge Slot Size Width.....	3/4 in.
Miter Gauge Slot Size Height.....	3/8 in.

### Construction

Table.....	Cast Iron
Wings.....	Cast Iron
Cabinet.....	Pre-Formed Steel
Trunnions.....	Cast Iron
Fence Assembly.....	Aluminum
Rails.....	Aluminum
Miter Gauge Construction.....	Aluminum
Guard.....	Aluminum and Plastic
Body/Cabinet Paint Type/Finish.....	Powder Coated
Arbor Bearings.....	Sealed and Permanently Lubricated

### Other Related Information

Number of Dust Ports.....	1
Dust Port Size.....	4 in.
Compatible Mobile Base.....	D2057A



# SECTION 1: SAFETY

## For Your Own Safety, Read Instruction Manual Before Operating This Machine

The purpose of safety symbols is to attract your attention to possible hazardous conditions. This manual uses a series of symbols and signal words intended to convey the level of importance of the safety messages. The progression of symbols is described below. Remember that safety messages by themselves do not eliminate danger and are not a substitute for proper accident prevention measures. Always use common sense and good judgment.



Indicates an imminently hazardous situation which, if not avoided, **WILL** result in death or serious injury.



Indicates a potentially hazardous situation which, if not avoided, **COULD** result in death or serious injury.



Indicates a potentially hazardous situation which, if not avoided, **MAY** result in minor or moderate injury. It may also be used to alert against unsafe practices.

**NOTICE**

This symbol is used to alert the user to useful information about proper operation of the machine.

## Safety Instructions for Machinery



**OWNER'S MANUAL.** Read and understand this owner's manual **BEFORE** using machine.

**TRAINED OPERATORS ONLY.** Untrained operators have a higher risk of being hurt or killed. Only allow trained/supervised people to use this machine. When machine is not being used, disconnect power, remove switch keys, or lock-out machine to prevent unauthorized use—especially around children. Make workshop kid proof!

**DANGEROUS ENVIRONMENTS.** Do not use machinery in areas that are wet, cluttered, or have poor lighting. Operating machinery in these areas greatly increases the risk of accidents and injury.

**MENTAL ALERTNESS REQUIRED.** Full mental alertness is required for safe operation of machinery. Never operate under the influence of drugs or alcohol, when tired, or when distracted.

**ELECTRICAL EQUIPMENT INJURY RISKS.** You can be shocked, burned, or killed by touching live electrical components or improperly grounded machinery. To reduce this risk, only allow qualified service personnel to do electrical installation or repair work, and always disconnect power before accessing or exposing electrical equipment.

**DISCONNECT POWER FIRST.** Always disconnect machine from power supply **BEFORE** making adjustments, changing tooling, or servicing machine. This prevents an injury risk from unintended startup or contact with live electrical components.

**EYE PROTECTION.** Always wear ANSI-approved safety glasses or a face shield when operating or observing machinery to reduce the risk of eye injury or blindness from flying particles. Everyday eyeglasses are **NOT** approved safety glasses.



# WARNING

**WEARING PROPER APPAREL.** Do not wear clothing, apparel or jewelry that can become entangled in moving parts. Always tie back or cover long hair. Wear non-slip footwear to reduce risk of slipping and losing control or accidentally contacting cutting tool or moving parts.

**HAZARDOUS DUST.** Dust created by machinery operations may cause cancer, birth defects, or long-term respiratory damage. Be aware of dust hazards associated with each workpiece material. Always wear a NIOSH-approved respirator to reduce your risk.

**HEARING PROTECTION.** Always wear hearing protection when operating or observing loud machinery. Extended exposure to this noise without hearing protection can cause permanent hearing loss.

**REMOVE ADJUSTING TOOLS.** Tools left on machinery can become dangerous projectiles upon startup. Never leave chuck keys, wrenches, or any other tools on machine. Always verify removal before starting!

**USE CORRECT TOOL FOR THE JOB.** Only use this tool for its intended purpose—do not force it or an attachment to do a job for which it was not designed. Never make unapproved modifications—modifying tool or using it differently than intended may result in malfunction or mechanical failure that can lead to personal injury or death!

**AWKWARD POSITIONS.** Keep proper footing and balance at all times when operating machine. Do not overreach! Avoid awkward hand positions that make workpiece control difficult or increase the risk of accidental injury.

**CHILDREN & BYSTANDERS.** Keep children and bystanders at a safe distance from the work area. Stop using machine if they become a distraction.

**GUARDS & COVERS.** Guards and covers reduce accidental contact with moving parts or flying debris. Make sure they are properly installed, undamaged, and working correctly **BEFORE** operating machine.

**FORCING MACHINERY.** Do not force machine. It will do the job safer and better at the rate for which it was designed.

**NEVER STAND ON MACHINE.** Serious injury may occur if machine is tipped or if the cutting tool is unintentionally contacted.

**STABLE MACHINE.** Unexpected movement during operation greatly increases risk of injury or loss of control. Before starting, verify machine is stable and mobile base (if used) is locked.

**USE RECOMMENDED ACCESSORIES.** Consult this owner's manual or the manufacturer for recommended accessories. Using improper accessories will increase the risk of serious injury.

**UNATTENDED OPERATION.** To reduce the risk of accidental injury, turn machine **OFF** and ensure all moving parts completely stop before walking away. Never leave machine running while unattended.

**MAINTAIN WITH CARE.** Follow all maintenance instructions and lubrication schedules to keep machine in good working condition. A machine that is improperly maintained could malfunction, leading to serious personal injury or death.

**DAMAGED PARTS.** Regularly inspect machine for damaged, loose, or mis-adjusted parts—or any condition that could affect safe operation. Immediately repair/replace **BEFORE** operating machine. For your own safety, **DO NOT** operate machine with damaged parts!

**MAINTAIN POWER CORDS.** When disconnecting cord-connected machines from power, grab and pull the plug—**NOT** the cord. Pulling the cord may damage the wires inside. Do not handle cord/plug with wet hands. Avoid cord damage by keeping it away from heated surfaces, high traffic areas, harsh chemicals, and wet/damp locations.

**EXPERIENCING DIFFICULTIES.** If at any time you experience difficulties performing the intended operation, stop using the machine! Contact our Technical Support at (570) 546-9663.



# Additional Safety for Table Saws

## WARNING

**HAND & BODY POSITIONING.** Touching a spinning saw blade will cause serious laceration or amputation injuries. Keep hands away from saw blade and out of blade path during operation, so they cannot slip accidentally into blade. Stand to side of blade path. Never reach around, behind, or over blade. Only operate at front of machine; never operate from rear or sides of saw.

**BLADE GUARD.** Use blade guard for all “through cuts” for which it can be used. (A through cut is an operation where blade cuts completely through the top of the workpiece.) Make sure the blade guard is installed and adjusted correctly; promptly repair or replace it if damaged. Always re-install blade guard immediately after operations that require its removal. Operating saw with blade guard removed greatly increases risk of severe laceration or amputation injuries from accidental blade contact.

**RIVING KNIFE.** Use the riving knife for all “non-through cuts” for which it can be used. (A non-through cut is an operation where the blade does not cut through the top of the workpiece.) Make sure the riving knife is aligned and positioned correctly; and promptly repair or replace it if damaged. Using the riving knife incorrectly will increase the risk of kickback or accidental blade contact.

**KICKBACK.** Kickback occurs when the saw blade ejects the workpiece back toward the operator. Know how to reduce the risk of kickback, and learn how to protect yourself if it does occur.

**FEEDING WORKPIECE.** Feeding workpiece incorrectly will increase risk of kickback. Never start saw with a workpiece touching blade; allow blade to reach full speed before cutting. Only feed workpiece against direction of blade rotation, from front of saw. Never pull workpiece from behind blade. Always use some type of guide (fence, miter gauge, sliding table or sled, etc.) to feed workpiece in a straight line. Never back a workpiece out of a cut or move it backwards or sideways after starting a cut. Feed cuts all the way through to completion. Never perform any operation “freehand” (making a cut without using a fence, miter gauge, or other guide). Never plunge cut.

**FENCE.** Make sure the fence remains properly adjusted and parallel with the blade. Always lock the fence in place before using. Using or adjusting the fence incorrectly will increase risk of kickback.

**PUSH STICKS/BLOCKS.** Use push sticks or push blocks whenever possible to keep your hands farther away from the blade while cutting; in the event of an accident these devices will often take damage that would have happened to hands/fingers.

**CUT-OFF PIECES.** Never use your hands to move cut-offs away from the blade while the saw is running. If a cut-off becomes trapped between the blade and table insert, turn the saw **OFF** and allow the blade to completely stop before removing it.

**BLADE ADJUSTMENTS.** Adjusting the blade height or tilt during operation increases the risk of crashing the blade and sending metal fragments flying with deadly force at the operator or bystanders. Only adjust the blade height and tilt when the blade is completely stopped and the saw is **OFF**.

**CHANGING BLADES.** Always disconnect power before changing blades. Changing blades while the saw is connected to power greatly increases the injury risk if saw is accidentally powered up.

**DAMAGED SAW BLADES.** Never use blades that have been dropped or otherwise damaged. Damaged blades can fly apart and strike the operator with shards of metal.

**DADO AND RABBET OPERATIONS.** DO NOT attempt dado or rabbeting operations without first reading those sections in this manual. Dado and rabbeting operations require special attention because they must be performed with the blade guard removed.

**CUTTING CORRECT MATERIAL.** Never cut materials not intended for this saw; only cut natural and man-made wood products, laminate covered wood products, and some plastics. Cutting metal, glass, stone, tile, etc. increases the risk of operator injury due to kickback or flying particles.



# Preventing Kickback

---

**Below are ways to avoid the most common causes of kickback:**

- Only cut workpieces with at least one smooth and straight edge. DO NOT cut warped, cupped or twisted wood.
- Keep the blade guard installed and working correctly for all through cuts.
- Never attempt freehand cuts. If the workpiece is not fed parallel with the blade, kickback will likely occur. Always use the rip fence or miter gauge to support the workpiece.
- Make sure the spreader or riving knife is aligned with the blade. A misaligned spreader or riving knife can cause the workpiece to catch or bind, increasing the chance of kickback.
- Take the time to check and adjust the rip fence parallel with the blade; otherwise, the chances of kickback are extreme.
- The spreader or riving knife maintains the kerf in the workpiece, reducing the chance of kickback. Always use the riving knife for all non-through operations, unless a dado blade is installed. Always use the spreader with the blade guard for all through cuts.
- Feed cuts through to completion. Anytime you stop feeding a workpiece in the middle of a cut, the chance of kickback is greatly increased.
- Keep the blade guard installed and in good working order. Only remove it when performing non-through cuts and immediately re-install the blade guard when finished. Remember, always use the riving knife for all non-through operations, unless a dado blade is installed.
- Make multiple, shallow passes when performing a non-through cut. Making a deep non-through cut will greatly increase the chance of kickback.

- Never move the workpiece backwards or try to back it out of a cut while the blade is moving. If you cannot complete a cut for some reason, stop the saw motor and allow the blade to completely stop before backing the workpiece out. Promptly fix the condition that prevented you from completing the cut before starting the saw again.

## Protecting Yourself From Kickback

---

**Even if you know how to prevent kickback, it may still happen. Here are some ways to protect yourself if kickback DOES occur:**

- Stand to the side of the blade during every cut. If kickback does occur, the thrown workpiece usually travels directly in front of the blade.
- Wear safety glasses or a face shield. In the event of kickback, your eyes and face are the most vulnerable parts of your body.
- Never, for any reason, place your hand behind the blade. Should kickback occur, your hand will be pulled into the blade, which could cause amputation.
- Use a push stick to keep your hands farther away from the moving blade. If kickback occurs, the push stick will most likely take the damage your hand would have received.
- Use featherboards or anti-kickback devices to assist with feeding and prevent or slow down kickback.

### CAUTION

**Statistics show that most common accidents among table saw users can be linked to kickback. Kickback is typically defined as the high-speed expulsion of stock from the table saw toward its operator. In addition to the danger of the operator or others in the area being struck by the flying stock, it is often the case that the operator's hands are pulled into the blade during kickback.**



# SECTION 2: POWER SUPPLY

## Availability

Before installing the machine, consider the availability and proximity of the required power supply circuit. If an existing circuit does not meet the requirements for this machine, a new circuit must be installed. To minimize the risk of electrocution, fire, or equipment damage, installation work and electrical wiring must be done by an electrician or qualified service personnel in accordance with all applicable codes and standards.

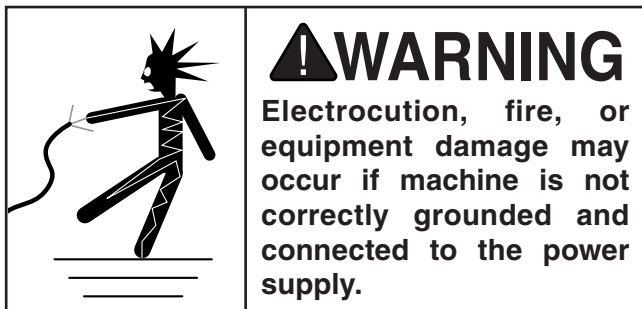

## Full-Load Current Rating

The full-load current rating is the amperage a machine draws at 100% of the rated output power. On machines with multiple motors, this is the amperage drawn by the largest motor or sum of all motors and electrical devices that might operate at one time during normal operations.

**Full-Load Current Rating at 120V ..... 15 Amps**

**Full-Load Current Rating at 240V .... 7.5 Amps**

The full-load current is not the maximum amount of amps that the machine will draw. If the machine is overloaded, it will draw additional amps beyond the full-load rating.

If the machine is overloaded for a sufficient length of time, damage, overheating, or fire may result—especially if connected to an undersized circuit. To reduce the risk of these hazards, avoid overloading the machine during operation and make sure it is connected to a power supply circuit that meets the specified circuit requirements.

## Circuit Information

A power supply circuit includes all electrical equipment between the breaker box or fuse panel in the building and the machine. The power supply circuit used for this machine must be sized to safely handle the full-load current drawn from the machine for an extended period of time. (If this machine is connected to a circuit protected by fuses, use a time delay fuse marked D.)

**! CAUTION**  
For your own safety and protection of property, consult an electrician if you are unsure about wiring practices or electrical codes in your area.

**Note:** *Circuit requirements in this manual apply to a dedicated circuit—where only one machine will be running on the circuit at a time. If machine will be connected to a shared circuit where multiple machines may be running at the same time, consult an electrician or qualified service personnel to ensure circuit is properly sized for safe operation.*

## Circuit Requirements for 120V

This machine is prewired to operate on a power supply circuit that has a verified ground and meets the following requirements:

**Nominal Voltage ..... 120V**  
**Cycle ..... 60 Hz**  
**Phase ..... Single-Phase**  
**Power Supply Circuit ..... 20 Amps**  
**Plug/Receptacle ..... NEMA 5-15**

## Circuit Requirements for 240V

This machine can be converted to operate on a power supply circuit that has a verified ground and meets the requirements listed below. (Refer to **Voltage Conversion** instructions for details.)

**Nominal Voltage ..... 240V**  
**Cycle ..... 60 Hz**  
**Phase ..... Single-Phase**  
**Power Supply Circuit ..... 15 Amps**  
**Plug/Receptacle ..... NEMA 6-15**



## Grounding Requirements

This machine **MUST** be grounded. In the event of certain malfunctions or breakdowns, grounding reduces the risk of electric shock by providing a path of least resistance for electric current.

**For 120V operation:** This machine is equipped with a power cord that has an equipment-grounding wire and a grounding plug (see following figure). The plug must only be inserted into a matching receptacle (outlet) that is properly installed and grounded in accordance with all local codes and ordinances.

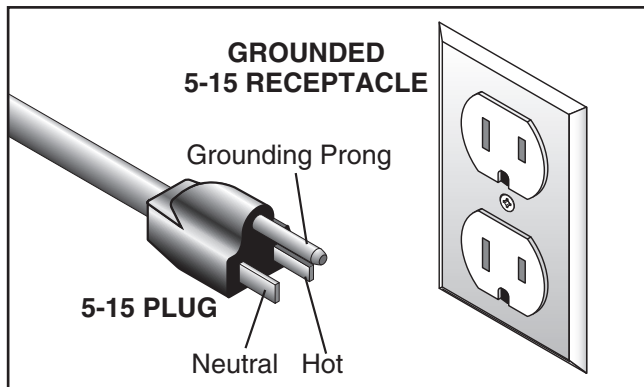
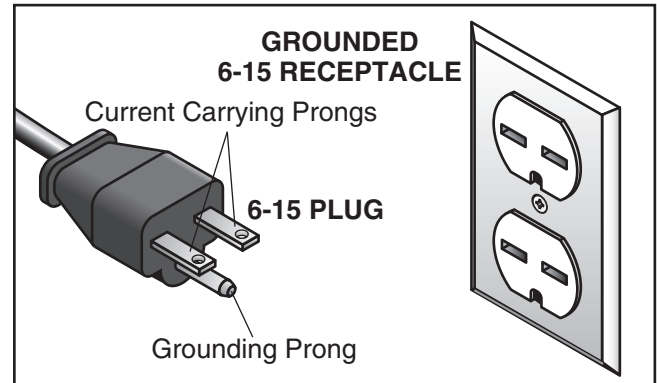

**Figure 5.** Typical 5-15 plug and receptacle.

**⚠ CAUTION**

**SHOCK HAZARD!**  
**Two-prong outlets do not meet the grounding requirements for this machine. Do not modify or use an adapter on the plug provided—if it will not fit the outlet, have a qualified electrician install the proper outlet with a verified ground.**

**For 240V operation:** The plug specified under “Circuit Requirements for 240V” on the previous page has a grounding prong that must be attached to the equipment-grounding wire on the included power cord. The plug must only be inserted into a matching receptacle (see following figure) that is properly installed and grounded in accordance with all local codes and ordinances.



**Figure 6.** Typical 6-15 plug and receptacle.

Improper connection of the equipment-grounding wire can result in a risk of electric shock. The wire with green insulation (with or without yellow stripes) is the equipment-grounding wire. If repair or replacement of the power cord or plug is necessary, do not connect the equipment-grounding wire to a live (current carrying) terminal.

Check with a qualified electrician or service personnel if you do not understand these grounding requirements, or if you are in doubt about whether the tool is properly grounded. If you ever notice that a cord or plug is damaged or worn, disconnect it from power, and immediately replace it with a new one.

## Extension Cords

We do not recommend using an extension cord with this machine. If you must use an extension cord, only use it if absolutely necessary and only on a temporary basis.

Extension cords cause voltage drop, which can damage electrical components and shorten motor life. Voltage drop increases as the extension cord size gets longer and the gauge size gets smaller (higher gauge numbers indicate smaller sizes).

Any extension cord used with this machine must be in good condition and contain a ground wire and matching plug/receptacle. Additionally, it must meet the following size requirements:

**Minimum Gauge Size ..... 12 AWG**  
**Maximum Length (Shorter is Better).....50 ft.**



# Converting Voltage to 240V

The voltage conversion **MUST** be performed by an electrician or qualified service personnel.

The voltage conversion procedure consists of rewiring the motor and installing the correct plug. A wiring diagram is provided on **Page 70** for your reference.

**IMPORTANT:** If the diagram included on the motor conflicts with the one on **Page 70**, the motor may have changed since the manual was printed. Use the diagram included on the motor instead.

Items Needed	Qty
• Phillips Head Screwdriver #2 .....	1
• Electrical Tape .....	As Needed
• Wire Nut (14 AWG x 3) .....	1
• Plug 6-15 .....	1
• Wire Cutters/Stripper .....	1

## To convert the Model G0771 to 240V:

1. DISCONNECT SAW FROM POWER!
2. Cut off the existing 5-15 plug.
3. Open the motor junction box, then loosen the two wire nuts indicated in **Figure 7**.

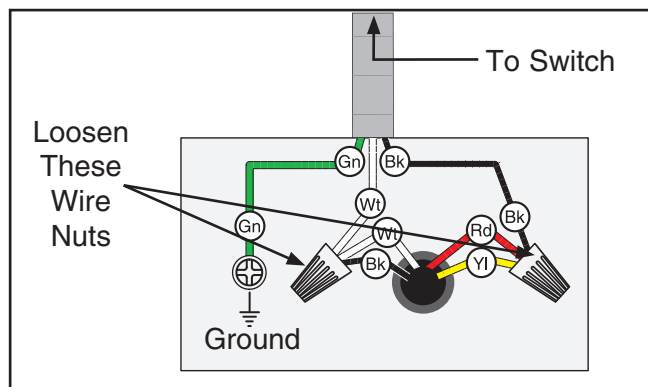

**Figure 7.** Inside motor junction box.

4. Use wire nuts to connect the wires as indicated in **Figure 8**. Twist the wire nuts onto their respective wires and wrap them with electrical tape so they will not come loose.

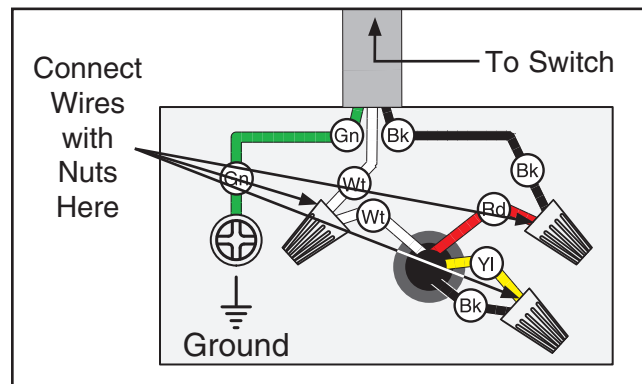

**Figure 8.** Motor rewired to 240V.

5. Close and secure the motor junction box.
6. Install a 6-15 plug on the power cord, according to the plug manufacturer's instructions. If the plug manufacturer's instructions are not available, NEMA standard 6-15 plug wiring is provided on **Page 70**.





# SECTION 3: SETUP

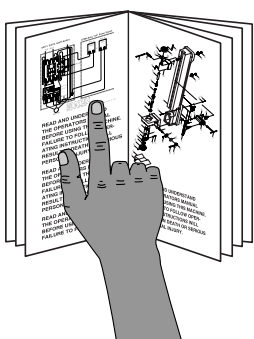

**⚠ CAUTION**  
This machine presents serious injury hazards to untrained users. Read through this entire manual to become familiar with the controls and operations before starting the machine!



**⚠ CAUTION**  
Wear safety glasses during the entire setup process!



**⚠ CAUTION**  
This machine and its components are very heavy. Get lifting help or use power lifting equipment such as a forklift to move heavy items.

## Unpacking

Your machine was carefully packaged for safe transportation. Remove the packaging materials from around your machine and inspect it. If you discover any damage, *please call us immediately at (570) 546-9663 for advice.*

Save the containers and all packing materials for possible inspection by the carrier or its agent. *Otherwise, filing a freight claim can be difficult.*

When you are completely satisfied with the condition of your shipment, inventory the contents.



**⚠ WARNING**  
**SUFFOCATION HAZARD!**  
Keep children and pets away from plastic bags or packing materials shipped with this machine. Discard immediately.

## Needed for Setup

The following are needed to complete the setup process, but are not included with your machine.

Description	Qty
• Additional People .....	1
• Safety Glasses for Each Person .....	1
• Cleaner/Degreaser ( <b>Page 54</b> ) ....	As Needed
• Disposable Shop Rags.....	As Needed
• Straightedge 4' .....	1
• Wrench or Socket 13mm.....	1
• Phillips Head Screwdriver #2 .....	1
• Flat Head Screwdriver #2.....	1
• Dust Collection System .....	1
• Dust Hose 4" .....	1
• Hose Clamps 4" .....	2
• Hex Wrench 8mm.....	1



# Inventory

The following is a list of items shipped with your machine. Before beginning setup, lay these items out and inventory them.

If any non-proprietary parts are missing (e.g. a nut or a washer), we will gladly replace them; or for the sake of expediency, replacements can be obtained at your local hardware store.

## Box 1 Contents (Figures 9–11): Qty

<b>A.</b> Main Table Saw Unit .....	1
<b>B.</b> Access Panel.....	1
<b>C.</b> Motor Cover.....	1
<b>D.</b> Extension Wings .....	2
<b>E.</b> Blade Guard Assembly .....	1
<b>F.</b> Table Insert.....	1
<b>G.</b> Dado Insert.....	1
<b>H.</b> Saw Blade 10" x 40T.....	1
<b>I.</b> Spreader/Riving Knife.....	1
<b>J.</b> Push Stick .....	1
<b>K.</b> Fence Handle with Mounting Bolt .....	1
<b>L.</b> Wrench 23mm Closed, 22mm Open.....	1 Ea
<b>M.</b> Handwheels.....	2
<b>N.</b> Connecting Bars.....	3
<b>O.</b> Miter Gauge Handle with Washer .....	1
<b>P.</b> Miter Gauge.....	1
<b>Q.</b> Star Knobs.....	2
<b>R.</b> Hex Wrenches 3, 4, 5, 6, 8mm .....	1 Ea
<b>S.</b> Fence Rail End Caps .....	4
<b>T.</b> Dust Port 4" .....	1

## Box 2 Contents (Figure 12): Qty

<b>U.</b> Fence.....	1
<b>V.</b> Front Fence Rail Sections.....	2
<b>W.</b> Rear Fence Rail Sections .....	2
<b>X.</b> Fence Rail Brace.....	1



Figure 9. Main table saw unit.

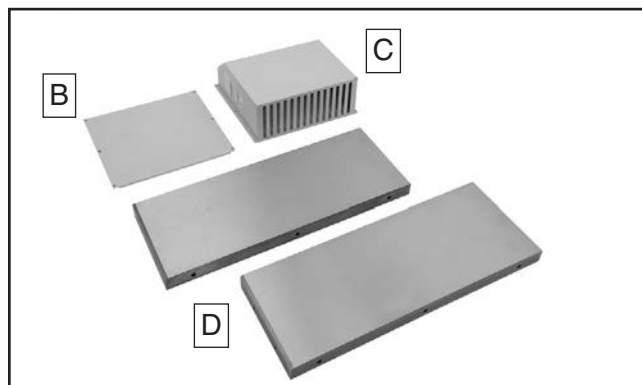

Figure 10. Extension wings and access panel.

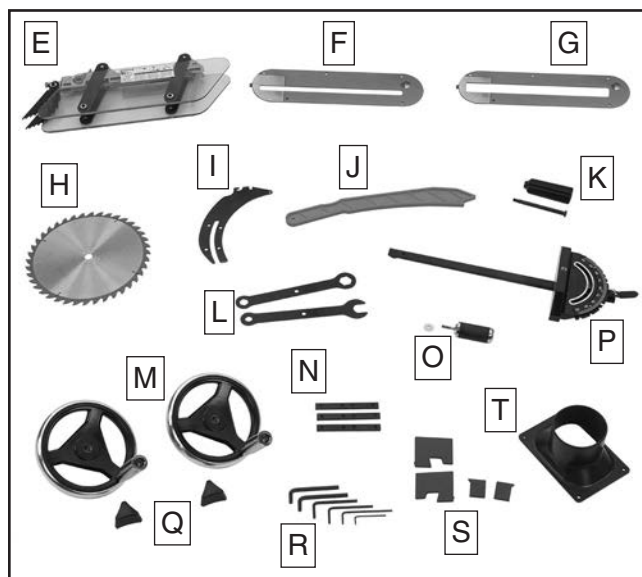

Figure 11. Component inventory.

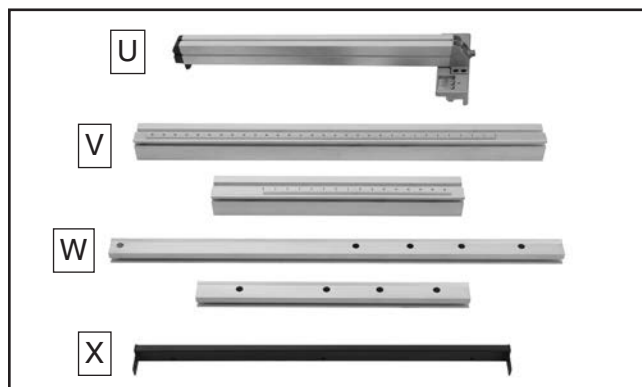

Figure 12. Fence rail brace and fence rails.

Hardware (Not Shown)	Qty
Cap Screws M10-1.5 x 30 .....	6
Cap Screws M8-1.25 x 20 .....	9
Hex Bolts M8-1.25 x 30 .....	9
Hex Nuts M8-1.25.....	16
Flat Washers 10mm .....	6
Lock Washers 10mm.....	6



# Cleanup

The unpainted surfaces of your machine are coated with a heavy-duty rust preventative that prevents corrosion during shipment and storage. This rust preventative works extremely well, but it will take a little time to clean.

Be patient and do a thorough job cleaning your machine. The time you spend doing this now will give you a better appreciation for the proper care of your machine's unpainted surfaces.

There are many ways to remove this rust preventative, but the following steps work well in a wide variety of situations. Always follow the manufacturer's instructions with any cleaning product you use and make sure you work in a well-ventilated area to minimize exposure to toxic fumes.

## Before cleaning, gather the following:

- Disposable rags
- Cleaner/degreaser (WD-40 works well)
- Safety glasses & disposable gloves
- Plastic paint scraper (optional)

## Basic steps for removing rust preventative:

1. Put on safety glasses.
2. Coat the rust preventative with a liberal amount of cleaner/degreaser, then let it soak for 5–10 minutes.
3. Wipe off the surfaces. If your cleaner/degreaser is effective, the rust preventative will wipe off easily. If you have a plastic paint scraper, scrape off as much as you can first, then wipe off the rest with the rag.
4. Repeat **Steps 2–3** as necessary until clean, then coat all unpainted surfaces with a quality metal protectant to prevent rust.

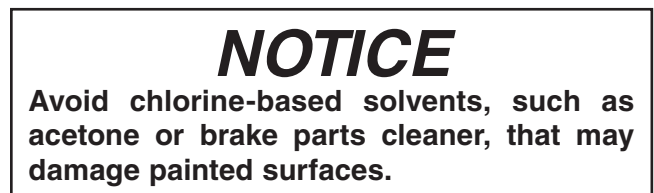
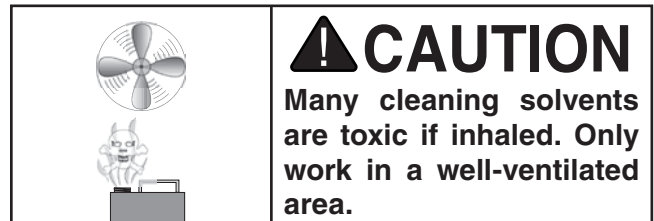
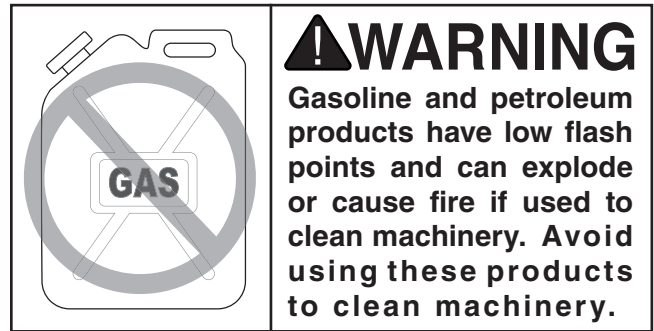

## T23692—Orange Power Degreaser

A great product for removing the waxy shipping grease from your machine during clean up.



Figure 13. T23692 Orange Power Degreaser.



# Site Considerations

## Weight Load

Refer to the **Machine Data Sheet** for the weight of your machine. Make sure that the surface upon which the machine is placed will bear the weight of the machine, additional equipment that may be installed on the machine, and the heaviest workpiece that will be used. Additionally, consider the weight of the operator and any dynamic loading that may occur when operating the machine.

## Space Allocation

Consider the largest size of workpiece that will be processed through this machine and provide enough space around the machine for adequate operator material handling or the installation of auxiliary equipment. With permanent installations, leave enough space around the machine to open or remove doors/covers as required by the maintenance and service described in this manual. **See below for required space allocation.**

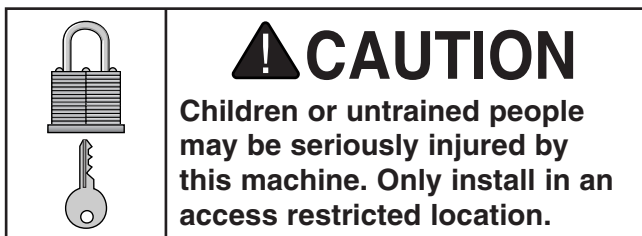

## Physical Environment

The physical environment where the machine is operated is important for safe operation and longevity of machine components. For best results, operate this machine in a dry environment that is free from excessive moisture, hazardous chemicals, airborne abrasives, or extreme conditions. Extreme conditions for this type of machinery are generally those where the ambient temperature range exceeds 41°–104°F; the relative humidity range exceeds 20%–95% (non-condensing); or the environment is subject to vibration, shocks, or bumps.

## Electrical Installation

Place this machine near an existing power source. Make sure all power cords are protected from traffic, material handling, moisture, chemicals, or other hazards. Make sure to leave enough space around machine to disconnect power supply or apply a lockout/tagout device, if required.

## Lighting

Lighting around the machine must be adequate enough that operations can be performed safely. Shadows, glare, or strobe effects that may distract or impede the operator must be eliminated.

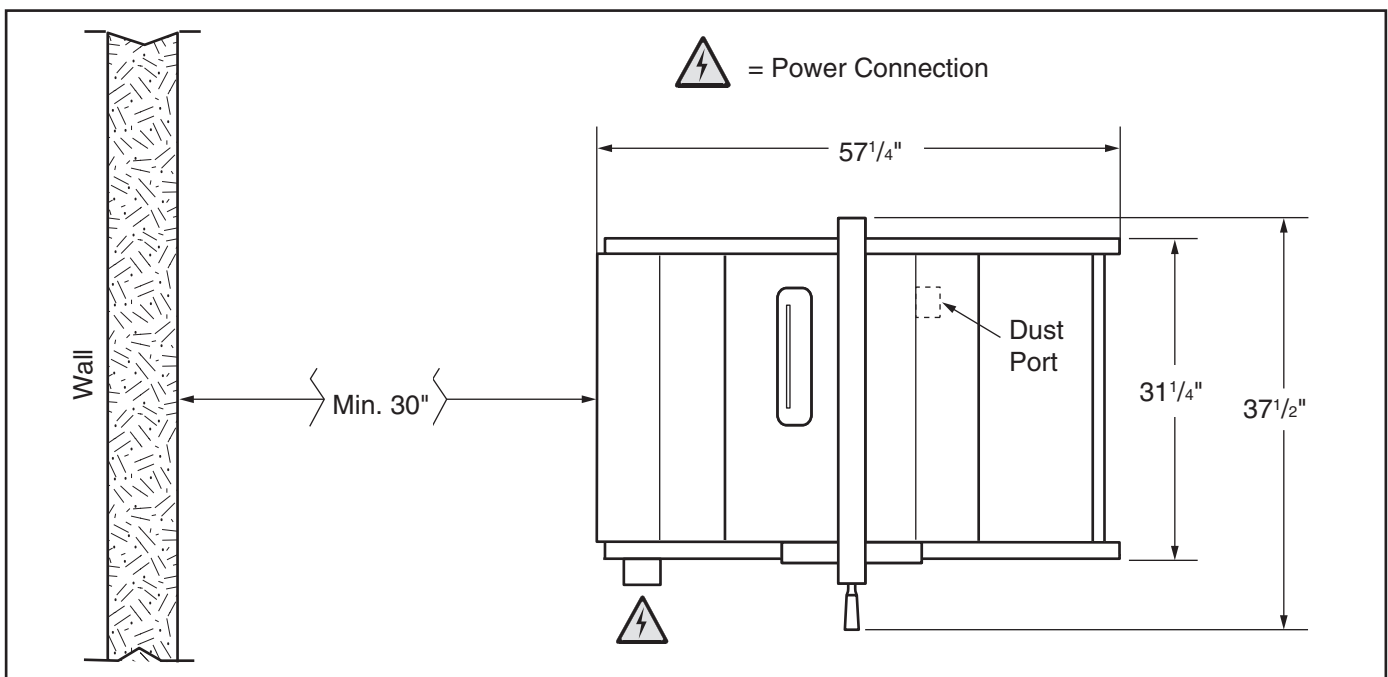

Figure 14. Minimum working clearances.



# Assembly

Assembly consists of installing the extension wings, fence rails, fence, blade, blade guard, and minor components.

## To assemble table saw:

1. Inspect extension wings and main table mating surfaces for burrs or foreign materials that may inhibit assembly.

For a correct fit, mating edges of table and wings must be clean, smooth, and flat. If necessary, use a wire brush or file to remove any flashing, dings, or high spots.

2. While a helper holds extension wings in place, attach each wing flush with main table using (3) M10-1.5 x 30 cap screws, 10mm flat washers, and 10mm lock washers (see **Figure 15**).

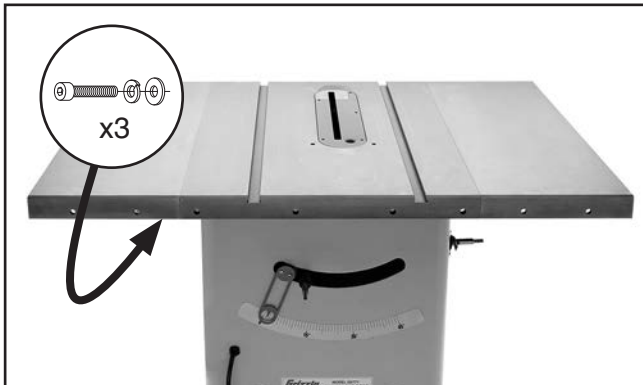
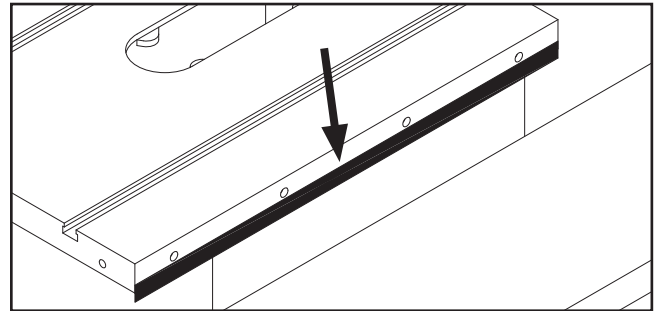

**Figure 15.** Extension wings installed.

3. Place a straightedge across extension wings and main table to ensure combined table surface is flat.

—If combined table surface is flat, skip to next step.

—If outside end of extension wing tilts down, remove wing and place a strip of masking tape along bottom edge of main table to shim end of wing up (see **Figure 16**).



**Figure 16.** Masking tape location for tilting the extension wing up.

—If outside end of extension wing tilts up, remove wing and place a strip of masking tape along top edge of main table to shim end of extension wing down (see **Figure 17**).

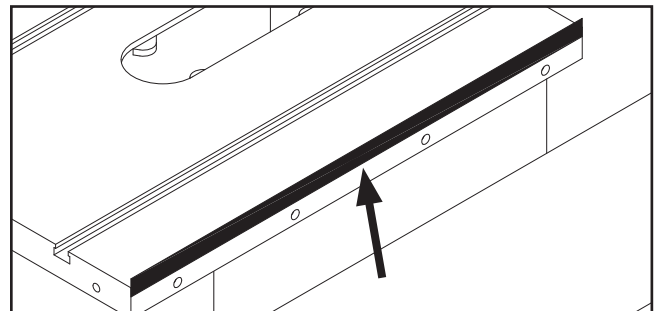

**Figure 17.** Masking tape location for tilting the extension wing down.

**Note:** After reinstalling wings, remove all excess masking tape with a razor blade.

4. Attach motor cover to cabinet using (6) pre-installed Phillips head screws (see **Figure 18**).

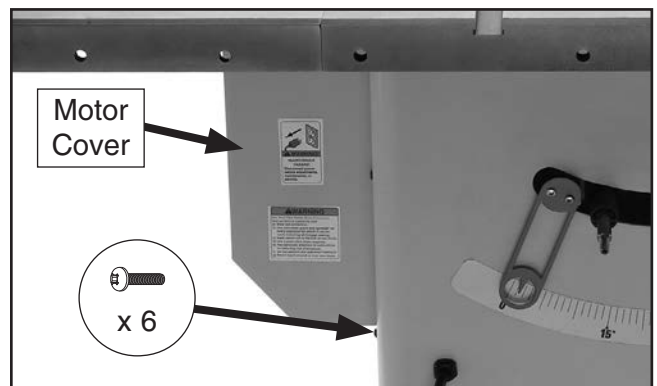

**Figure 18.** Motor cover installed.



5. Insert two connecting bars into long section of front fence rail and tighten set screws, then slide short section of rail onto connecting bars and tighten set screws (see **Figure 19**).

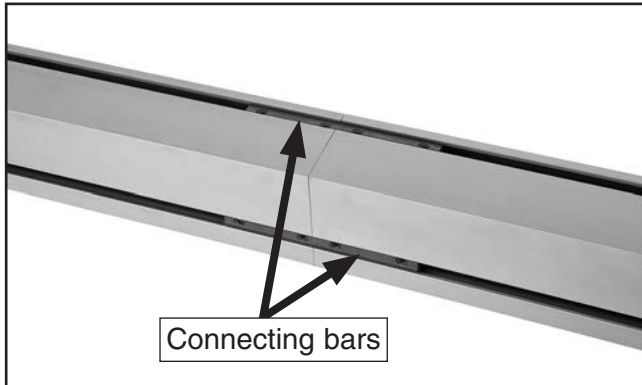

**Figure 19.** Front fence rail assembled.

6. Insert connecting bar into long section of rear fence rail and tighten set screws, then slide short section of rail onto connecting bar and tighten set screws (see **Figure 20**).

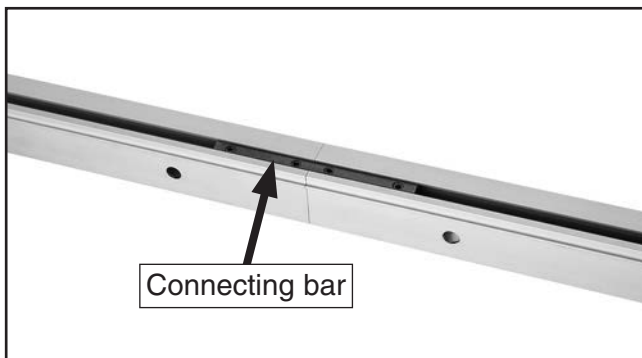

**Figure 20.** Rear fence rail assembled.

7. Remove (2) M8-1.25 x 16 hex bolts from switch and insert into bottom slot on left end of fence rail (see **Figure 21**). These will be used later for mounting the switch.

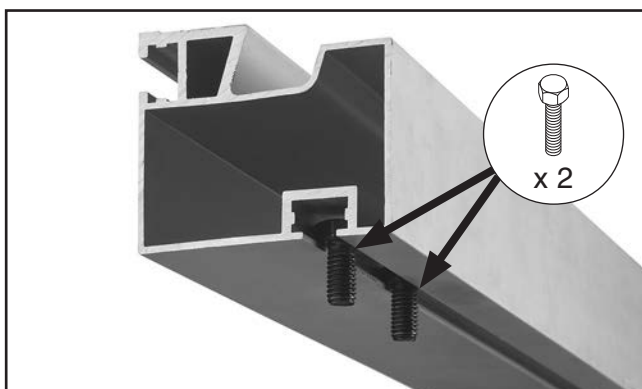

**Figure 21.** Hex bolts for mounting switch.

8. Install end cap with (2) pre-installed tap screws on left end of front fence rail (see **Figure 22**).

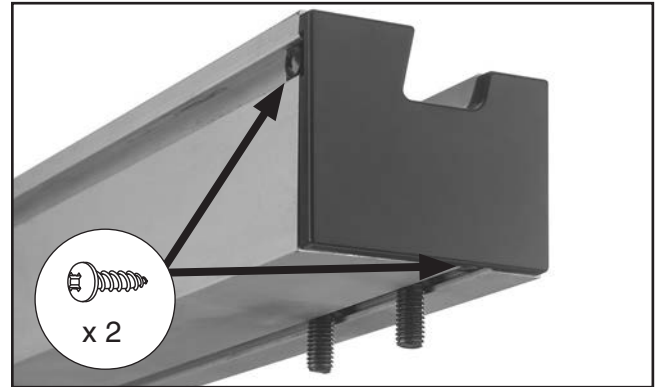

**Figure 22.** Left end cap on front fence rail.

9. Orient fence rail so scale is facing you. Slide (4) M8-1.25 x 30 hex bolts into slot on right end of rail and (4) M8-1.25 x 30 hex bolts into slot on left (see **Figure 23**).

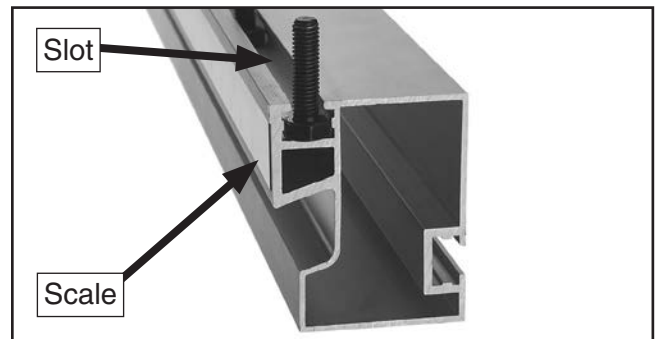

**Figure 23.** Hex bolt positioned in front fence rail slot.

10. Align hex bolts in fence rail with holes in table, then insert bolts into table. Be sure scale on fence rail is facing up. Hand tighten (8) M8-1.25 hex nuts onto hex bolts. Do not fully tighten yet (see **Figure 24**).



**Figure 24.** Mounting front fence rail.

11. Install switch onto hex bolts from **Step 6** using (2) M8-1.25 hex nuts (see **Figure 25**).



**Figure 25.** Switch installed.

12. Install rear fence rail on backside of table using (8) M8-1.25 x 20 cap screws. Be sure lip of fence rail faces up and away from table, as shown in **Figure 26**.

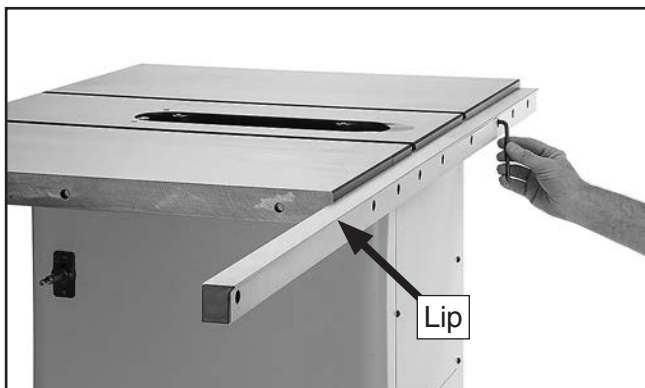

**Figure 26.** Mounting rear fence rail.

13. Install table/dado insert in table throat (see **Figure 27**). Check to make sure it is flush and adjust if necessary (see **Table/Dado Insert Adjustment** on **Page 66** for more information).



**Figure 27.** Table insert installed.

14. Install handwheels on shafts, making sure notch in each wheel fits over pin on each shaft, and secure with star knobs, as shown in **Figure 28**.

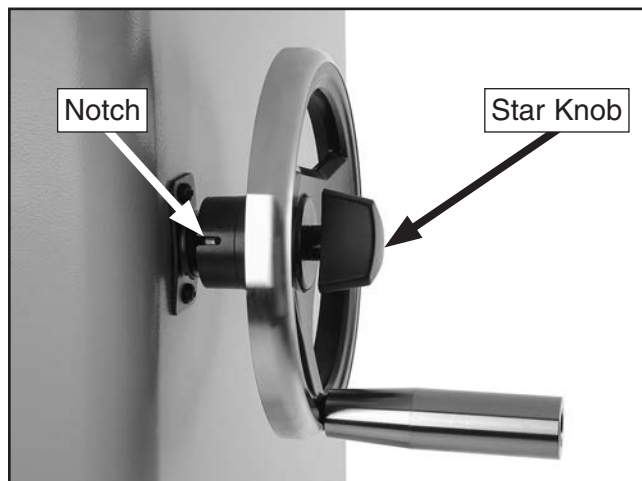

**Figure 28.** Handwheel Installed.

15. Install saw blade as instructed in **Blade Installation** on **Page 29**.

16. Raise motor slightly, using blade height handwheel, and remove styrofoam block that supports motor during shipping (see **Figure 29**).



**Figure 29.** Location of styrofoam block to be removed.



17. Install fence handle using flat head screwdriver (see **Figure 30**).

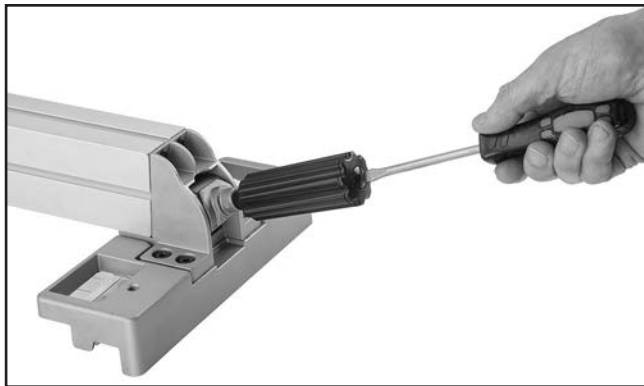

**Figure 30.** Installing fence handle.

18. Place rear of fence over lip of rear fence rail, then press front of fence into channel of front fence rail (see **Figure 31**).



**Figure 31.** Fence installed.

19. Using blade height handwheel, raise blade 1–2 inches.
20. Turn blade tilt handwheel until blade tilt indicator on front of machine points to 0° on blade angle scale (see **Figure 32**).



**Figure 32.** Blade tilt indicator and angle scale.

21. Slide fence so it lightly touches right side of blade (see **Figure 33**). Do not lock fence.

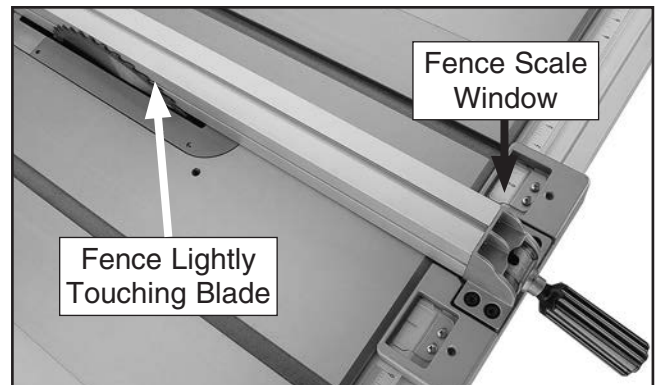
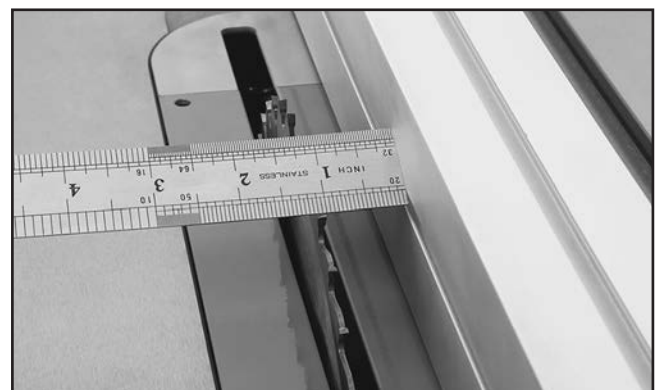

**Figure 33.** Fence scale calibration.

22. Nudge fence rail so zero mark of scale on right lines up with cross-hair in fence scale window (see **Figure 33**).
23. Tighten hex nuts to secure fence rail.
24. Check fence scale calibration by moving fence to 1" mark on scale and measuring distance from blade (see **Figure 34**).

—If crosshair aligns exactly with 1" mark, no adjustments need to be made.

—If crosshair does *not* align with 1" mark, loosen fence scale window screws, move crosshair over 1" mark, then tighten screws.



**Figure 34.** Checking calibration of fence scale.

25. Lower blade and move fence to left side of blade.
26. Raise blade 1–2 inches.
27. Slide fence so it lightly touches left side of blade.





28. Check left fence scale window.

—If crosshair aligns with zero mark on left fence scale, no adjustments need to be made.

—If crosshair does not align with zero mark on scale, loosen fence scale window screws, move crosshair over zero mark, then tighten screws.

29. Lower blade completely.

30. Using a helper, mount fence rail brace to rear fence rail with (1) M8-1.25 x 20 cap screw and M8-1.25 hex nut (see **Figure 35**).

**Note:** Do not tighten cap screw yet.

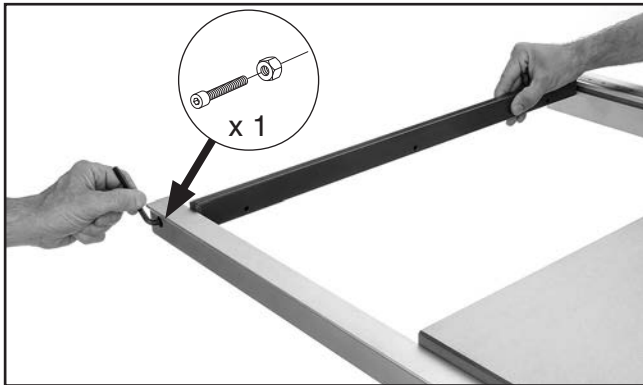

**Figure 35.** Attaching rear of fence rail brace.

31. Insert (1) M8-1.25 x 30 hex bolt into front end of fence rail brace, then slide tab of brace and hex head into slot in front fence rail (see **Figure 36**).

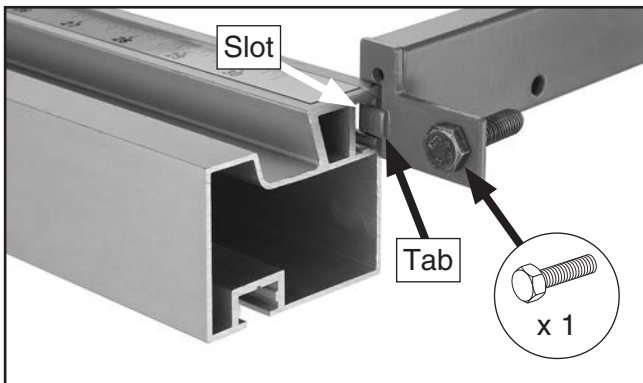

**Figure 36.** Attaching front end of fence rail brace.

32. Tighten cap screw and hex nut on rear end of fence rail brace.

33. Measure distance from edge of table to rear end of fence rail brace, then adjust front end of fence rail brace so it is the same distance from the table edge (see **Figure 37**).



**Figure 37.** Fence rail brace installed.

34. Secure hex bolt on front of rail brace with (1) M8-1.25 hex nut.

35. Install end cap on right end of front fence rail in the same manner as you did on the left end (**Step 8 on Page 20**).

36. Install end caps on rear fence rail by pushing into place.

37. Secure rear access panel with (6) pre-installed Phillips head screws.

38. Mount dust port with (4) pre-installed Phillips Head screws (see **Figure 38**).

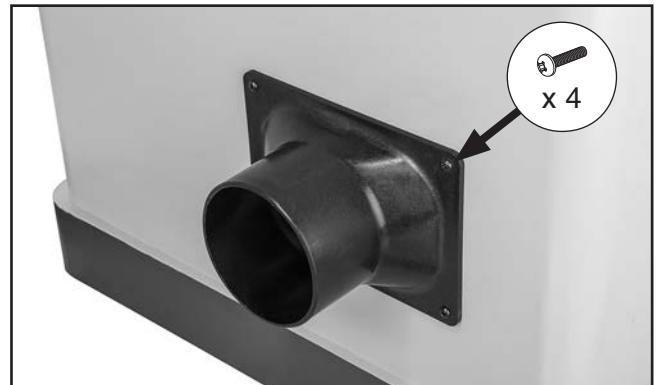

**Figure 38.** Dust port installed.



# Dust Collection

## ⚠ CAUTION

This machine creates substantial amounts of dust during operation. Breathing airborne dust on a regular basis can result in permanent respiratory illness. Reduce your risk by wearing a respirator and capturing the dust with a dust collection system.

### Recommended CFM at Dust Port: 400 CFM

Do not confuse this CFM recommendation with the rating of the dust collector. To determine the CFM at the dust port, you must consider these variables: (1) CFM rating of the dust collector, (2) hose type and length between the dust collector and the machine, (3) number of branches or wyes, and (4) amount of other open lines throughout the system. Explaining how to calculate these variables is beyond the scope of this manual. Consult an expert or purchase a good dust collection "how-to" book.

### To connect a dust collection hose:

1. Fit 4" dust hose over dust port, as shown in **Figure 39**, and secure in place with a hose clamp.
2. Tug hose to make sure it does not come off. **Note:** A tight fit is necessary for proper performance.



**Figure 39.** Example of dust hose attached to dust port.

# Test Run

Once assembly is complete, test run the machine to ensure it is properly connected to power and safety components are functioning properly.

If you find an unusual problem during the test run, immediately stop the machine, disconnect it from power, and fix the problem **BEFORE** operating the machine again. The **Troubleshooting** table in the **SERVICE** section of this manual can help.

The test run consists of verifying the following:  
1) The motor powers up and runs correctly, and  
2) the safety disabling mechanism on the switch works correctly.

## ⚠ WARNING

Serious injury or death can result from using this machine **BEFORE** understanding its controls and related safety information. **DO NOT** operate, or allow others to operate, machine until the information is understood.

## ⚠ WARNING

**DO NOT** start machine until all preceding setup instructions have been performed. Operating an improperly set up machine may result in malfunction or unexpected results that can lead to serious injury, death, or machine/property damage.

### To test run machine:

1. Make sure you have read safety instructions at beginning of manual and that machine is set up properly.
2. Lower blade all the way down, and make sure all tools and objects used during setup are cleared away from machine.
3. Connect machine to power source.
4. Turn machine **ON**, verify motor operation, then turn machine **OFF**.

The motor should run smoothly and without unusual problems or noises.



5. Remove switch disabling key, as shown in **Figure 40**.

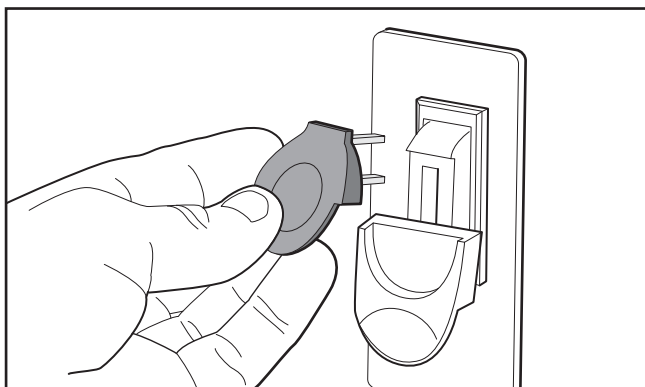

**Figure 40.** Removing switch disabling key from paddle switch.

6. Try to start machine with paddle switch.
- If machine does not start, switch disabling feature is working as designed.
  - If machine starts, immediately stop machine. The switch disabling feature is not working correctly. This safety feature must work properly before proceeding with regular operations. Call Tech Support for help.

## Recommended Adjustments

---

For your convenience, the adjustments listed below have been performed at the factory and no further setup is required to operate this machine. However, because of the many variables involved with shipping, we recommend that you verify the following adjustments to ensure that this saw cuts safely and accurately.

Step-by-step instructions for these adjustments can be found in **SECTION 7: SERVICE**.

### Adjustments that should be verified:

1. Blade Tilt Stop Accuracy (**Page 59**).
2. Miter Slot Parallel to Blade (**Page 61**).
3. Table/Dado Insert Adjustment (**Page 66**).



# SECTION 4: OPERATIONS

## Operation Overview

The purpose of this overview is to provide the novice machine operator with a basic understanding of how the machine is used during operation, so the machine controls/components discussed later in this manual are easier to understand.

Due to the generic nature of this overview, it is **not** intended to be an instructional guide. To learn more about specific operations, read this entire manual and seek additional training from experienced machine operators, and do additional research outside of this manual by reading "how-to" books, trade magazines, or websites.

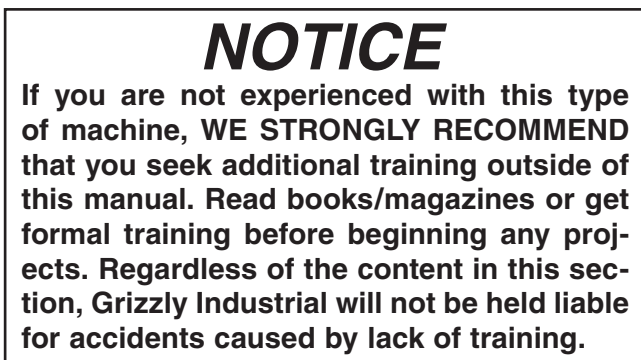
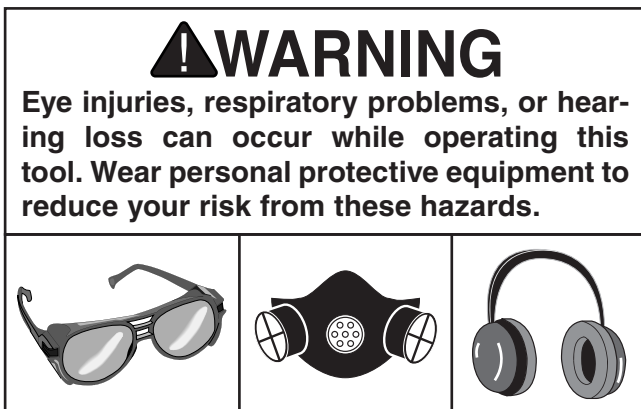

To complete a typical operation, the operator does the following:

1. Examines workpiece to make sure it is suitable for cutting.
2. Adjusts blade tilt, if necessary, to correct angle of desired cut.
3. Adjusts blade height approximately ¼" higher than thickness of workpiece.
4. Adjusts fence to desired width of cut, then locks it in place.
5. Checks outfeed side of machine for proper support and to make sure workpiece can safely pass all the way through blade without interference.
6. Puts on safety glasses and a respirator, and locates push sticks if needed.
7. Starts saw.
8. Feeds workpiece all the way through blade while maintaining firm pressure on workpiece against table and fence, and keeping hands and fingers out of blade path and away from blade.
9. Stops machine immediately after cut is complete.



# Workpiece Inspection

Some workpieces are not safe to cut or may require modification before they are safe to cut. **Before cutting, inspect all workpieces for the following:**

- **Material Type:** This machine is intended for cutting natural and man-made wood products, laminate covered wood products, and some plastics. Cutting drywall or cementitious backer board creates extremely fine dust and may reduce the life of the bearings. This machine is NOT designed to cut metal, glass, stone, tile, etc.; cutting these materials with a table saw may lead to injury.
- **Foreign Objects:** Nails, staples, dirt, rocks and other foreign objects are often embedded in wood. While cutting, these objects can become dislodged and hit the operator, cause kickback, or break the blade, which might then fly apart. Always visually inspect your workpiece for these items. If they can't be removed, DO NOT cut the workpiece.
- **Large/Loose Knots:** Loose knots can become dislodged during the cutting operation. Large knots can cause kickback and machine damage. Choose workpieces that do not have large/loose knots or plan ahead to avoid cutting through them.
- **Wet or "Green" Stock:** Cutting wood with a moisture content over 20% causes unnecessary wear on the blades, increases the risk of kickback, and yields poor results.
- **Excessive Warping:** Workpieces with excessive cupping, bowing, or twisting are dangerous to cut because they are unstable and often unpredictable when being cut. DO NOT use workpieces with these characteristics!
- **Minor Warping:** Workpieces with slight cupping can be safely supported if the cupped side is facing the table or the fence. On the contrary, a workpiece supported on the bowed side will rock during a cut and could cause kickback or severe injury.

# Non-Through & Through Cuts

## Non-Through Cuts

A non-through cut is a sawing operation where the blade does not protrude above the top face of the wood stock, as shown in the **Figure** below.

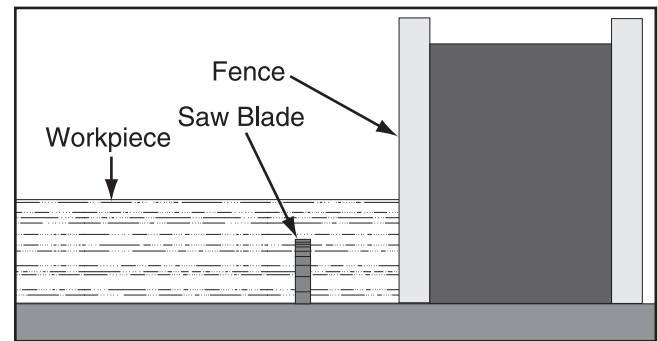

**Figure 41.** Example of a non-through cut.

Examples of non-through cuts include dados and rabbets. Non-through cuts have a higher risk of injury from kickback because the blade guard must be removed. However, the riving knife **MUST** be installed because it still provides some protection. When making non-through cuts with a dado blade, do not attempt to cut the full depth in one pass. Instead, take multiple light passes to reduce the load on the blade. A dado blade smaller than 10" will require removal of the riving knife, because the riving knife will be higher than the blade.



## Through Cuts

A through cut is a sawing operation in which the workpiece is completely sawn through, as shown in the **Figure** below. Examples of through cuts are rip cuts, cross cuts, miter cuts, and beveled cuts. The blade guard assembly **MUST** be used when performing through cuts.

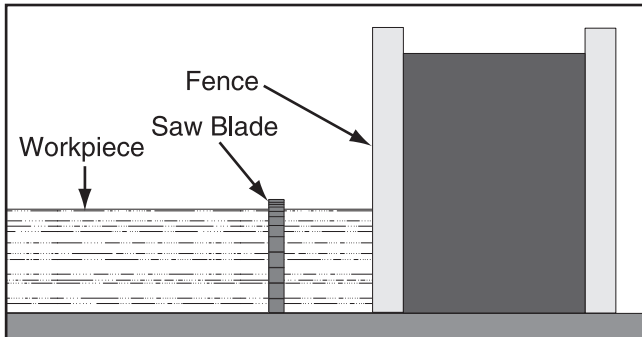

**Figure 42.** Example of a through cut (blade guard not shown for illustrative clarity).

## Blade Requirements

The spreader/ripping knife included with this machine is 0.090" (2.3mm) thick and is only designed for 10" diameter blades.

When choosing a main blade, make sure the blade size meets the requirements listed below. The thickness of the blade body and teeth can be measured with calipers or any precision measuring device.

### Blade Size Requirements:

- Body Thickness: 0.060"-0.086" (1.5-2.1mm)
- Kerf (Tooth) Thickness: 0.094"-0.126" (2.4-3.2mm)

## Blade Selection

This section on blade selection is by no means comprehensive. Always follow the saw blade manufacturer's recommendations to ensure safe and efficient operation of your table saw.

### Ripping Blade Features:

- Best for cutting with the grain
- 20-40 teeth
- Flat-top ground tooth profile
- Large gullets for large chip removal

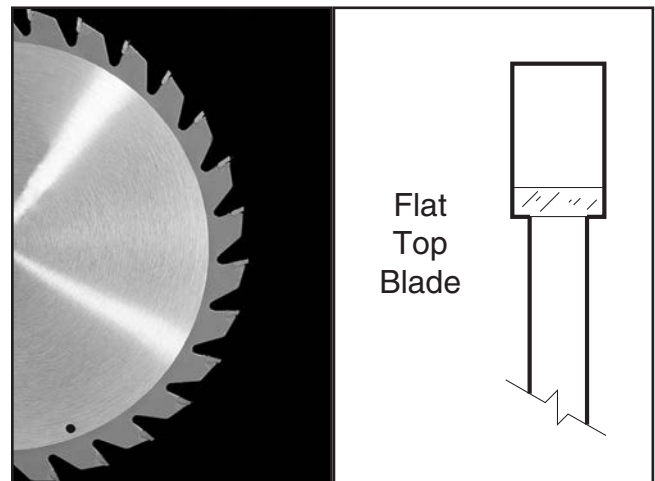

**Figure 43.** Ripping blade.

### Crosscut blade features:

- Best for cutting across the grain
- 60-80 teeth
- Alternate top bevel tooth profile
- Small hook angle and a shallow gullet

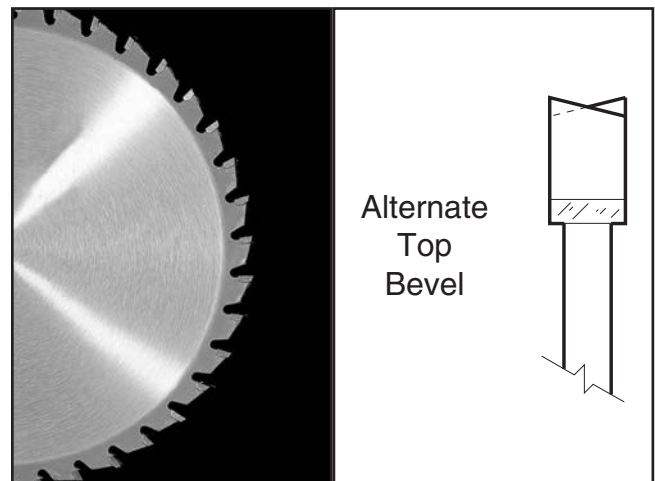

**Figure 44.** Crosscutting blade.



### Combination blade features:

- Designed to cut both with and across grain
- 40-50 teeth
- Alternate top bevel and flat, or alternate top bevel and raker tooth profile
- Teeth are arranged in groups
- Gullets are small and shallow (similar to a cross-cut blade), then large and deep (similar to a ripping blade)

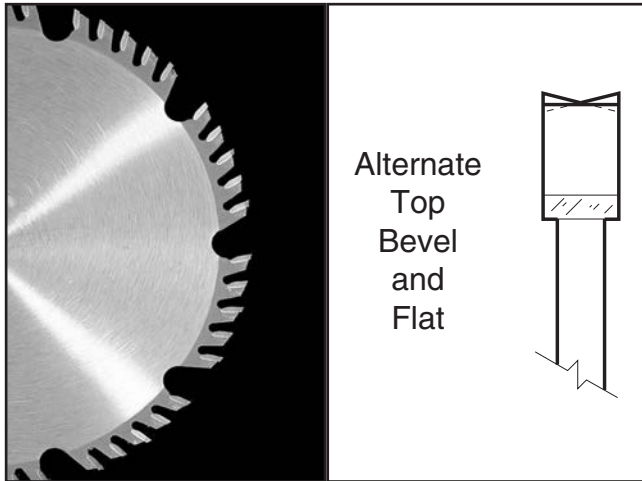

Figure 45. Combination blade.

### Laminate blade features:

- Best for cutting plywood or veneer
- 40-80 teeth
- Triple chip tooth profile
- Very shallow gullet

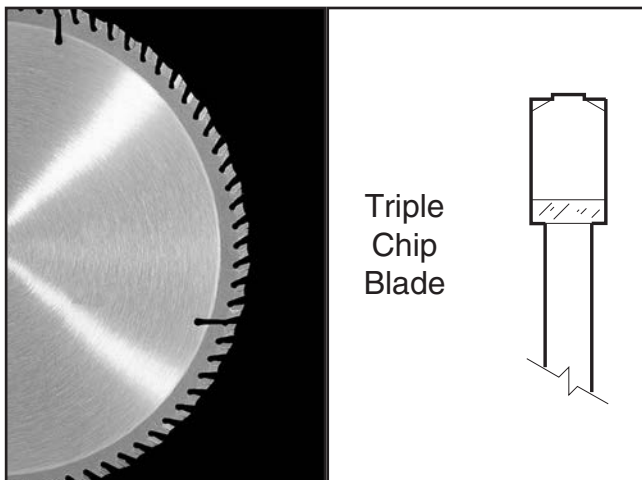

Figure 46. Laminate blade.

**Thin Kerf Blade:** A blade with thinner kerf than a standard blade. Since the spreader/riving knife included with this table saw is sized for standard blades, thin kerf blades cannot be used on this saw unless they meet the **Blade Requirements** specified in this manual; otherwise, they will increase the risk of kickback.

### Dado Blades

**Stacked Dado Blade (see below):** Multiple blades are stacked together to control the cutting width. Stacked dado blades are more expensive than wobble blades, but typically produce higher quality results.

**Wobble Dado Blade:** A single blade mounted at a slight angle on an arbor hub. The blade angle is adjustable on the hub, and the width of the dado cut is controlled by the angle setting of the blade.

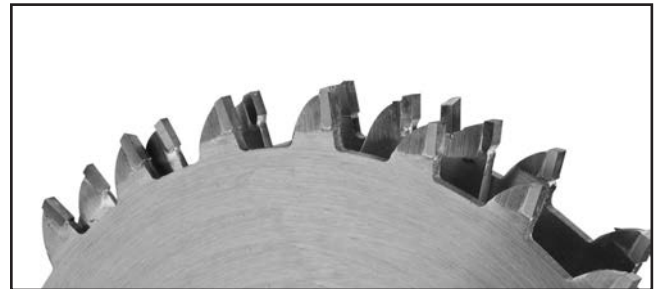
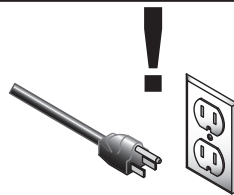

Figure 47. Stacked dado blade.

## Blade Installation

### ⚠ CAUTION

To reduce the risk of injury, always disconnect power to the saw before changing blades. Since the blade is sharp, use extra care and wear gloves when installing it.



### To install a new blade:

1. DISCONNECT SAW FROM POWER!

Continued on next page →



2. Raise arbor all the way up, remove blade guard, table insert (leave Phillips head screws mounted in table throat), and spreader/riving knife.

**Note:** Table insert is held in place by magnet.

3. Use included arbor wrenches to loosen and remove arbor nut, flange, and blade (see **Figure 48**). Arbor nut has right hand threads; turn counterclockwise to loosen.

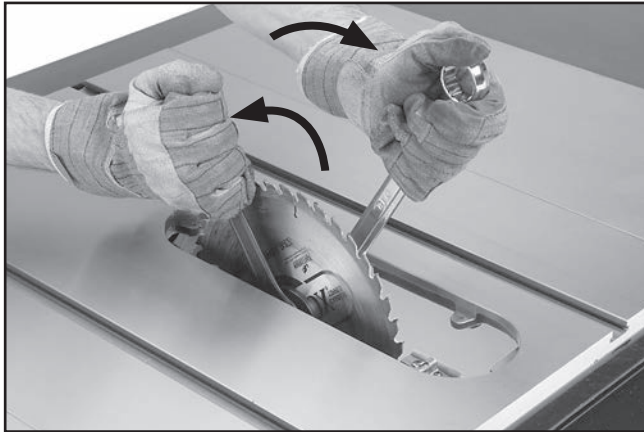

**Figure 48.** Example of removing table saw blade.

4. Install new blade, flange and arbor nut on arbor, as shown in **Figure 49**, with teeth facing front of the saw.

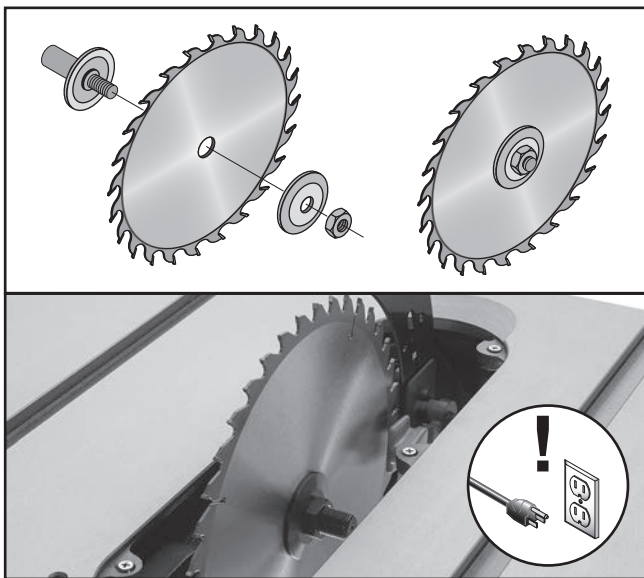
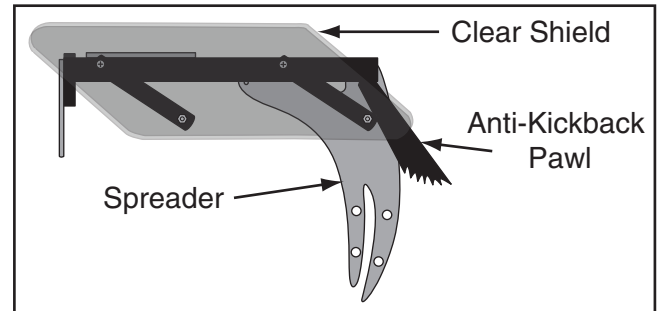

**Figure 49.** Correct order of installation with teeth facing the correct direction.

5. Re-install spreader/riving knife, table insert (see **Page 66**), and blade guard.

## Blade Guard Assembly

The term "blade guard" refers to the assembly that consists of the clear polycarbonate shield, the spreader, and the anti-kickback pawls on each side of the spreader (see **Figure 50**). Each of these components has important safety functions during the operation of the saw.



**Figure 50.** Blade guard assembly components.

### Guard

The clear polycarbonate guard allows the operator to watch the blade cut the workpiece during operation. This guard is designed to lift as the workpiece is pushed into the blade and remain in contact with the workpiece throughout the entire cut.

The guard reduces injury risk by providing a barrier around the blade that prevents accidental contact and contains flying wood chips.

To ensure that the guard does its job effectively, the guard must always be in the downward position against the table during idle operation, and the hinge mechanism must be maintained in good working condition so the guard can freely pivot up and down to accommodate the height of the workpiece and return to the table surface.





## Spreader/Riving Knife

The spreader/riving knife is a metal plate that prevents the newly cut kerf of the workpiece from pinching the back side of the blade, causing kickback.

The spreader/riving knife also acts as a barrier behind the blade to shield hands from being pulled into the blade if a kickback occurs.

### **⚠ CAUTION**

In order to work properly, the spreader cannot be bent or misaligned with the blade. If the spreader accidentally gets bent, take the time to straighten it or just replace it. Using a bent or misaligned spreader will increase the risk of kickback! Refer to Page 63 to check or adjust alignment if necessary.

## Installing Blade Guard & Spreader/Riving Knife

1. DISCONNECT SAW FROM POWER!
2. Remove table insert, but leave Phillips head screws mounted in table throat.
3. Raise blade all the way up.
4. Insert lower set of holes on spreader/riving knife into bracket slot, and tighten lock lever to secure spreader (see **Figure 51**).

**Note:** Do not insert upper set of holes on spreader into bracket slot. Doing so will result in improper installation of blade guard.

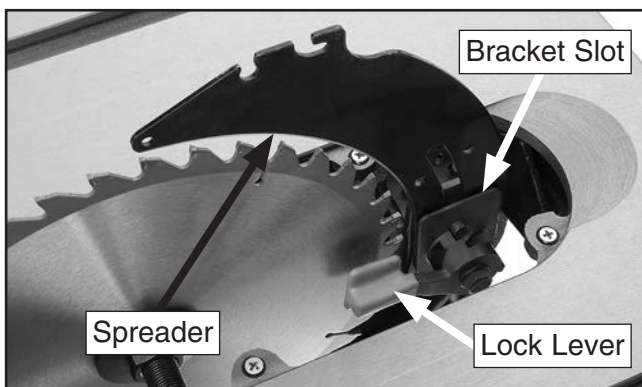

**Figure 51.** Lock lever used to secure spreader/riving knife.

5. Re-install table insert (refer to **Table/Dado Insert Adjustment** on **Page 66**).
6. Tug spreader upward to verify it is locked.
7. Push guard lever forward.
8. Insert rear pin on blade guard into rear slot of spreader, then push down on blade guard assembly so forward pin slides into forward slot of spreader (see **Figure 52**).

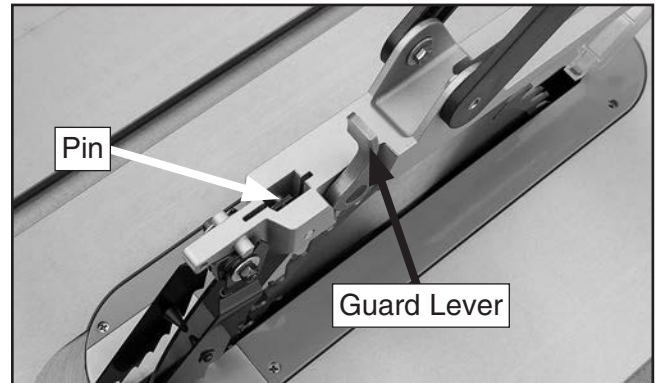

**Figure 52.** Blade guard installation.

9. Push guard lever toward rear of saw, locking blade guard.
10. Tug upward on blade guard assembly to verify that it is locked into spreader.

When properly installed, the blade guard should be set up similarly to **Figure 53**. It should pivot freely up and down and return to the table in the resting position. It should also swing up high enough to accommodate the workpiece.

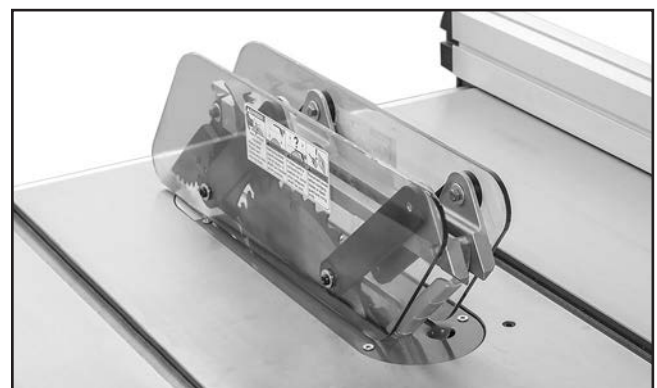
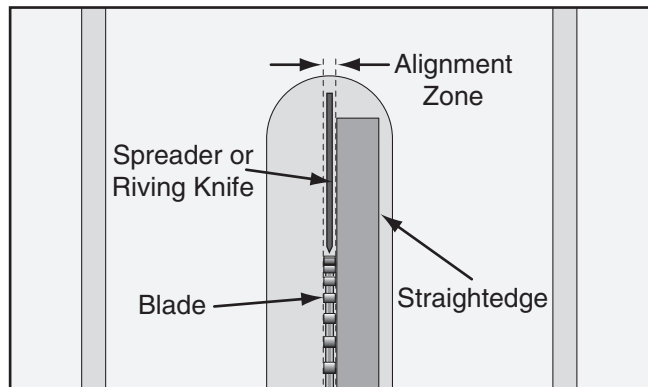

**Figure 53.** Blade guard installed.



11. Swing one side of blade guard up and out of the way.
12. While lifting up on right spreader pawl, place a straightedge against blade and spreader, making sure straightedge does not touch a blade tooth.

When properly aligned, spreader/riving knife will be in "Alignment Zone," shown in **Figure 54**, and will be parallel with blade.

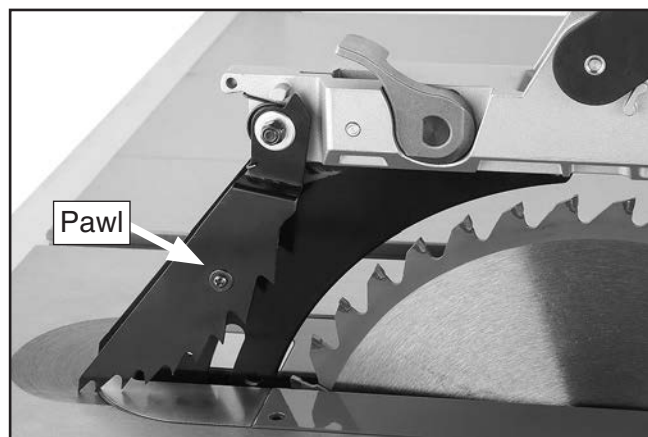

**Figure 54.** Spreader/riving knife alignment zone.

### Anti-Kickback Pawls

The anti-kickback pawls allow the workpiece to travel in only one direction. If the workpiece moves backwards, such as during a kickback, the pawls will dig into the workpiece to slow or stop it.

To work properly, the pawls must return to their resting position after pivoting, shown in **Figure 55**.



**Figure 55.** Pawls in resting position.

If the pawls fail to return to the resting position, the pivot area may need to be cleaned or the spring may have been dislodged or broken and will need to be fixed/replaced.

### Disabling Pawls

You might disable the pawls if you are concerned about them scratching a delicate workpiece, or if you believe that they will obstruct a narrow workpiece and cause feeding difficulty or loss of control. Use your best judgment before retracting the pawls, as they are provided for your safety.

## **CAUTION**

We do not recommend disabling the pawls during normal operations unless absolutely necessary. In most situations, disabling the pawls will increase your risk of serious personal injury in the event of a kickback.

## **CAUTION**

The pawls are sharp and can lacerate fingers or hands. Use caution, and wear leather gloves when handling the pawls to reduce the risk of injury.

To disable pawls:

1. DISCONNECT SAW FROM POWER!
2. Remove cap screw, locking hex nut, washers, pawls, and retaining spring from blade guard assembly (see **Figure 56**).

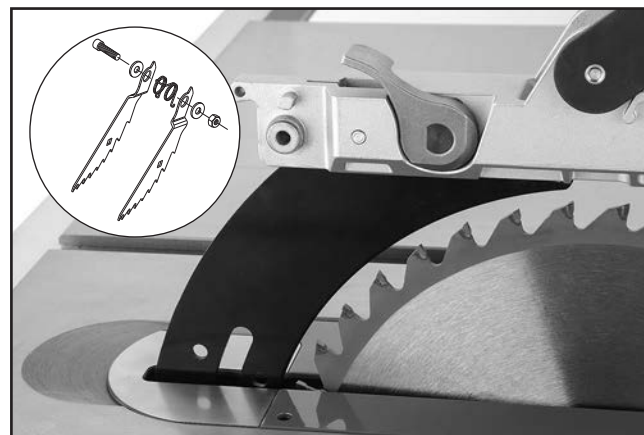

**Figure 56.** Pawls Removed.



### Enabling Pawls

To enable the pawls, re-install retaining spring, pawls, washers, cap screw, and locking hex nut onto blade guard assembly. Do not overtighten.

### When to Use the Blade Guard

The blade guard assembly **MUST** always be installed on the saw for all normal through cuts (those where the blade cuts all the way through the thickness of the workpiece). If the blade guard is removed for specific operations, always immediately replace it after those operations are complete.

### When Not to Use the Blade Guard

The blade guard cannot be used on any non-through cuts (those in which the blade does not cut all the way through the thickness of the workpiece).

**IMPORTANT:** Whenever the blade guard cannot be used, the spreader/ripping knife must be installed.

Sometimes the blade guard or its components can get in the way when cutting very narrow workpieces or other specialized cuts. Because the blade guard is provided to decrease your risk of injury, it should not be used if it gets in the way of making a safe cut. Use good judgment!

## Riving Knife

The spreader also functions as riving knife, which works in the same manner as the spreader, but is used for non-through cuts. It is a metal plate that prevents the newly cut workpiece from pinching the backside of the blade and causing kickback.

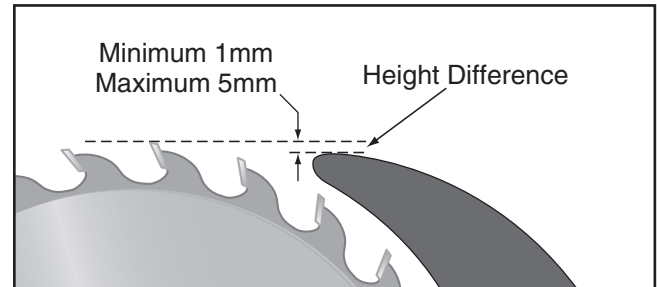

**Figure 57.** Example of height difference between riving knife and blade.

Similar to the spreader, the riving knife acts as a barrier behind the blade to reduce the risk of hands being pulled into the blade if kickback occurs.

When used as a riving knife, the spreader/ripping knife must be kept within the range shown in **Figure 58**. For that reason, a 10" blade is required for operations that use a riving knife.

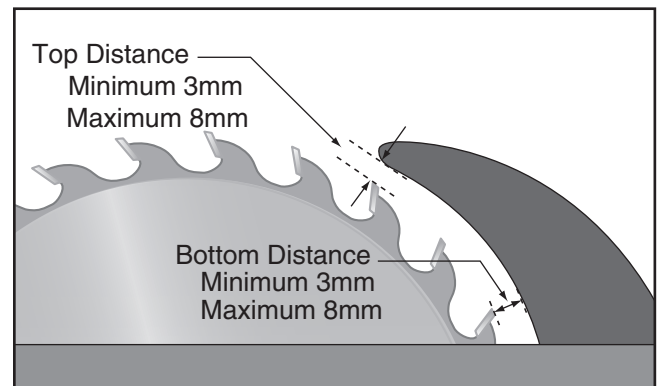

**Figure 58.** Example of allowable top and bottom distances between riving knife and blade.



## **!WARNING**

To ensure that the riving knife works safely, it **MUST** be aligned with and correctly adjusted to the blade. Refer to Page 63 to check or adjust the riving knife alignment.

### To install riving knife:

1. DISCONNECT SAW FROM POWER!
2. Remove table insert, but leave Phillips head screws mounted in table throat.

**Note:** Table insert is held in place by magnet.

3. Raise blade all the way up.
4. Insert *upper* set of holes on spreader/riving knife into bracket slot and tighten lock lever to secure spreader/riving knife (see **Figure 59**).

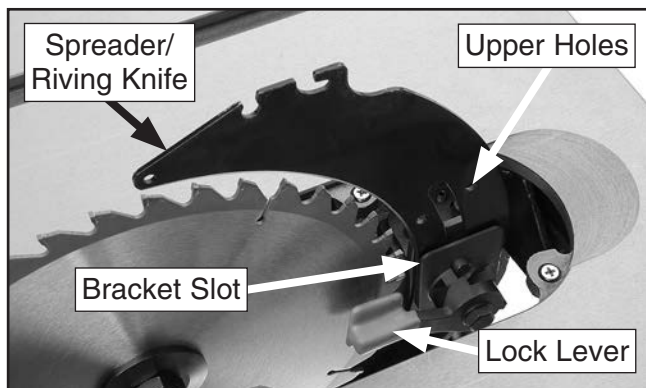

**Figure 59.** Lock lever used to secure spreader.

5. Re-install table insert (refer to **Page 66**).
6. Tug upward on top of spreader/riving knife to verify it is locked.

### When to Use the Riving Knife

Use the riving knife for all non-through cuts made with a standard table saw blade (i.e., dados or rabbet cuts, and when using a tenoning jig), or when using a 10" diameter dado blade.

Also, use the riving knife for those special operations where the blade guard or its components get in the way of safe operation, such as with very narrow cuts.

### When Not to Use the Riving Knife

Do not use the riving knife with a dado blade that has a diameter smaller than 10" in diameter. Otherwise, the riving knife height will exceed the blade height and the workpiece will hit the riving knife during the cut, forcing the operator into a dangerous situation of trying to turn the saw off with the workpiece stuck halfway through the cut.

In addition, although it is possible to use the riving knife for through cutting operations, the blade guard assembly offers far more injury protection and risk reduction than the riving knife. Therefore, **we strongly recommend** that you use the blade guard assembly for through cuts.

## Ripping

"Ripping" means cutting with the grain of a natural wood workpiece. In man-made materials such as MDF or plywood, ripping simply means cutting lengthwise.

## **!CAUTION**

Serious injury can be caused by kickback. Kickback is a high-speed ejection of stock from the table saw toward an operator. The operator or bystanders may be struck by flying stock, or the operator's hands can be pulled into the blade during kickback.

### To make a rip cut:

1. Review **Preventing Kickback** on **Page 11** and take necessary precautions to reduce likelihood of kickback.
2. If using natural wood, joint one long edge of workpiece on a jointer.
3. DISCONNECT SAW FROM POWER!
4. Ensure that blade guard/spreader is installed.
5. Set fence to desired width of cut on scale.
6. Adjust blade height so highest saw tooth protrudes no more than 1/4" above workpiece.



7. Set up safety devices such as featherboards or other anti-kickback devices, making sure no safety devices are contacting blade.

8. Plug saw into power source, turn it **ON**, and allow it to reach full speed.

**Note:** *Jointed edge of workpiece must slide against fence during cutting operation.*

9. Use a push stick to feed workpiece through saw blade, as shown in **Figure 60**, until workpiece is completely beyond saw blade.

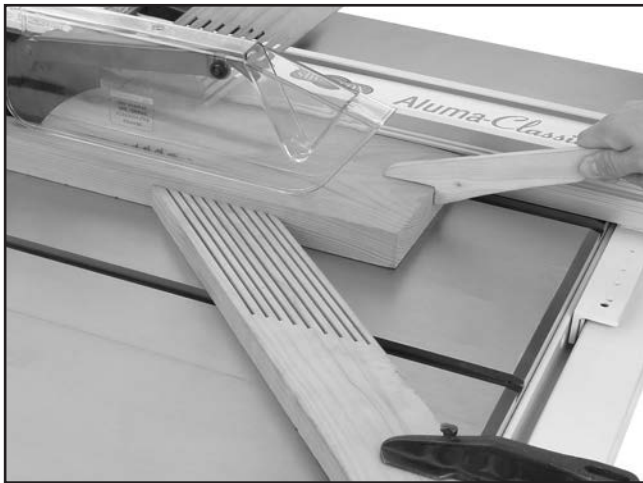
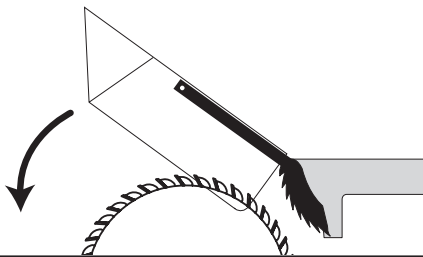

**Figure 60.** Typical ripping operation.

## **!WARNING**

Turn saw **OFF** and allow blade to come to a complete stop before removing cutoff piece. Failure to follow this warning could result in severe lacerations or amputation.

## **!WARNING**



Keep blade guard installed and in down position. Failure to do this could result in serious personal injury or death.

# Crosscutting

"Crosscutting" means cutting across the grain of a natural wood workpiece, usually with a miter saw. In other man-made materials, such as MDF or plywood, crosscutting means cutting across the width of the workpiece.

**To make a crosscut using miter gauge:**

1. DISCONNECT SAW FROM POWER!
2. Ensure that blade guard/spreader is installed.
3. Move rip fence aside and position miter gauge, adjusted to 90°, in a miter slot.
4. Adjust blade height so teeth protrude no more than 1/4" above workpiece.
5. Slide miter gauge near blade and adjust workpiece so blade will cut on waste side of line.
6. Plug in table saw, turn it **ON**, and allow it to reach full speed.
7. Hold workpiece firmly against face of miter gauge (as shown in **Figure 61**), and ease it through blade until workpiece is completely past saw blade.

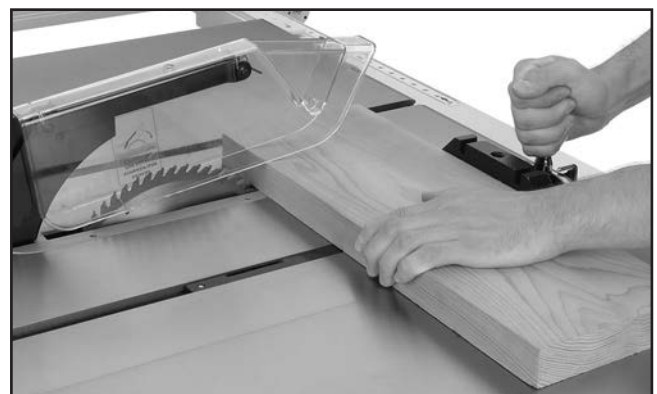

**Figure 61.** Typical crosscutting operation.

## **!WARNING**

Turn saw **OFF** and allow blade to come to a complete stop before removing cutoff piece. Failure to follow this warning could result in severe lacerations or amputation.



# Miter Cuts

A miter is an angled crosscut. Miters are usually cut in the same manner as crosscuts, using the miter gauge and a predetermined mark on the workpiece.

**To perform a miter cut:**

1. DISCONNECT SAW FROM POWER!
2. Ensure that blade guard/spreader is installed.
3. Determine angle of cut. If angle needs to be very precise, use a protractor to set miter gauge to blade.
4. Place face of miter gauge against edge of workpiece and place bar across face of workpiece. Use bar as a guide to mark your cut, as shown in **Figure 62**.

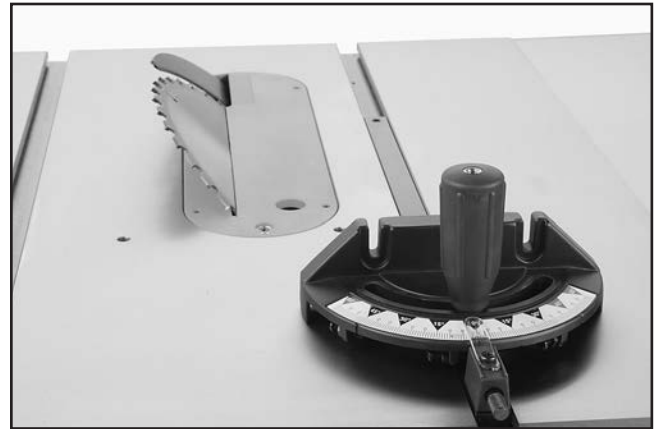

**Figure 62.** Example of marking miter line.

5. Place miter gauge back into slot and hold workpiece firmly against miter gauge body. Slide miter gauge near blade and adjust workpiece so blade will cut on waste side of line.
6. Proceed to make cut in same manner as described in **Crosscutting** instructions.

# Blade Tilt/Bevel Cuts

When the blade tilt adjustment bolts are properly adjusted (as described on **Page 59**), the blade tilt handwheel allows the operator to tilt the blade to the left, between  $0^\circ$  and  $45^\circ$ . This is used most often when cutting bevels, compound miters, or chamfers. **Figure 63** shows an example of the blade when tilted to  $45^\circ$ .



**Figure 63.** Example of blade tilted to  $45^\circ$  for bevel cutting (blade guard only removed for clarity).

# Dado Cutting

Commonly used in furniture joinery, a dado is a straight channel cut in the face of the workpiece. Dados are "non-through" cuts that can be made with a dado blade or a standard saw blade. The **Figure** below shows a cutaway view of a dado cut being made with a dado blade.

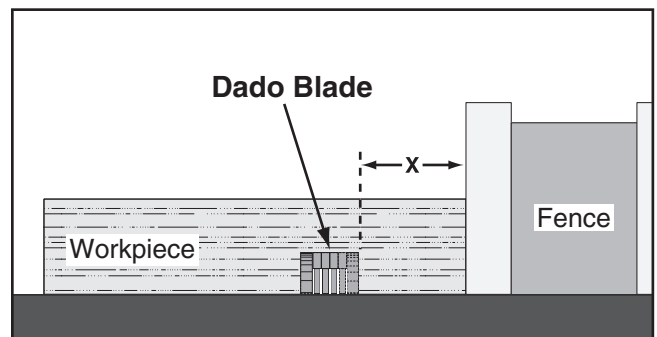

**Figure 64.** Example of a dado being cut with a dado blade.



The Model G0771 can accommodate dado blades up to 10" in diameter. However, you MUST install the included riving knife while using a 10" diameter dado blade, as it provides a barrier behind the blade and reduces the risk of hands being pulled into the blade if kickback occurs.

DO NOT use the riving knife if you install a dado blade smaller than 10" in diameter. Otherwise, the riving knife height will exceed the blade height and the workpiece will hit the riving knife during the cut, forcing the operator into a dangerous situation and trying to turn the saw off with the workpiece stuck halfway through the cut.

### Installing a Dado Blade

1. DISCONNECT SAW FROM POWER!
2. Remove table insert, blade guard assembly, spreader/riving knife, and saw blade.
3. Attach and adjust dado blade system according to dado blade manufacturer's instructions.
4. Install included dado table insert.

### **!WARNING**

**DO NOT** make through cuts with a dado blade. The extra width of a dado blade will increase the risk of kickback during a through cut. Dado blades are only intended for non-through cuts. Failure to heed this warning could result in serious injury.

### **!WARNING**

**Never** try to cut a warped board by holding it down against the table. If kickback occurs, your hand could be pulled into the blade, resulting in accidental contact with the rotating blade, causing severe lacerations or amputation.

### Cutting Dadoes with a Dado Blade

Because dado blades are much wider than standard blades, they place a greater amount of force against the workpiece when cutting. This additional force increases the risk of kickback, requiring the operator to take additional steps when cutting to keep their injury risk at an acceptable level.

### **!WARNING**

**Dado blades have a higher risk of kickback than normal blades because their larger size applies stronger forces to the workpiece. This risk increases relative to the depth and width of the cut. To minimize your risk of serious personal injury, ensure that stock is flat and straight, and make multiple light cuts (rather than one deep cut) to achieve the desired cutting depth.**

The **Figure** below demonstrates the sequential process of making multiple, light cuts that get progressively deeper. The actual number of cuts used should be determined by workpiece hardness, total dado depth, and feed rate. In general, if you hear the motor slow down during the cut, you are cutting too deep or feeding too fast.

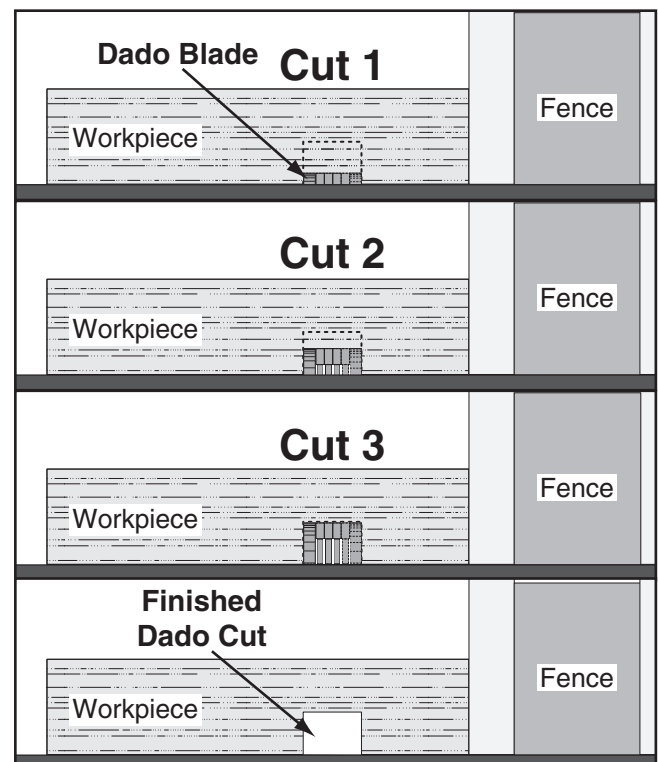

**Figure 65.** Example of dado being cut with multiple light cuts, instead of one deep cut.



### To cut a dado with a dado blade:

1. DISCONNECT SAW FROM POWER!
2. Adjust dado blade to desired depth of cut.
3. Adjust distance between fence and inside edge of blade, as shown in **Figure 64** on **Page 36**, to dado length of a workpiece.

— If dadoing across workpiece, use miter gauge and carefully line up desired cut with dado blade. DO NOT use fence in combination with miter gauge.

4. Reconnect saw to power source.
5. Turn saw **ON**. Blade should run smoothly, with no vibrations.
6. When blade has reached full speed, perform test cut with scrap piece of wood.
7. If cut is satisfactory, repeat cut with actual workpiece.

### Cutting Dados with a Standard Blade

A ripping blade (described on **Page 28**) is typically the best blade to use when cutting dados with a standard blade because it removes sawdust very efficiently.

### To use a standard saw blade to cut dados:

1. DISCONNECT SAW FROM POWER!
2. Mark width of dado cut on workpiece. Include marks on edge of workpiece so cut path can be aligned when workpiece is lying on table.
3. Raise blade up to desired depth of cut (depth of dado channel desired).
4. Set saw up for type of cut you need to make, depending on whether it is a rip cut (**Page 34**) or crosscut (**Page 35**).

5. Align blade to cut one side of dado, as shown in **Figure 66**.

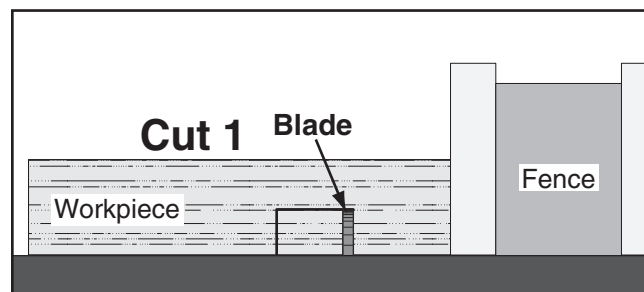

**Figure 66.** First cut for a single-blade dado.

6. Reconnect saw to power source and turn saw **ON**. Allow blade to reach full speed, then perform cutting operation.
7. Repeat cutting operation on other side of dado, as shown in **Figure 67**.

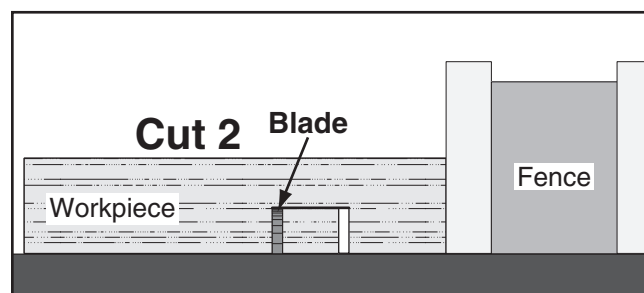

**Figure 67.** Second cut for a single-blade dado.

8. Make additional cuts (see **Figure 68**) in center of dado to clear out necessary material. Dado is complete when channel is completely cleared out.

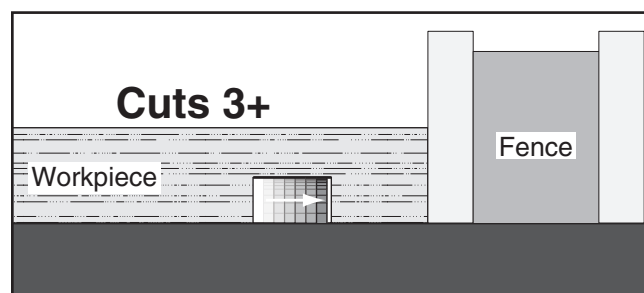

**Figure 68.** Additional single-blade dado cuts.





# Rabbet Cutting

Commonly used in furniture joinery, a rabbet is an L-shaped groove cut in the edge of the workpiece. Rabbets can be cut with either a dado blade or a standard saw blade.

Rabbet cutting along the edge of a workpiece with a dado blade requires a sacrificial fence (**Figure 69**). Make the sacrificial fence the same length as the fence and  $\frac{3}{4}$ " thick. Attach it to the fence with screws or clamps, making sure they are all secure and tight. Raise the blade into the sacrificial fence to the height needed.

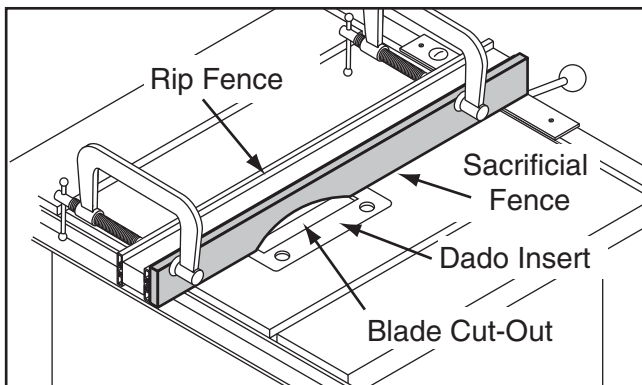

**Figure 69.** Example of sacrificial fence.

When using a dado blade, the included dado table insert must be installed and used during rabbeting operations.

## **!WARNING**

Dado blades have a higher risk of kickback than normal blades because their larger size applies stronger forces to the workpiece. This risk increases relative to the depth and width of the cut. To minimize your risk of serious personal injury, ensure that stock is flat and straight, and make multiple light cuts (rather than one deep cut) to achieve the desired cutting depth.

## **!CAUTION**

Always use push sticks, featherboards, push paddles and other safety accessories whenever possible to increase control and reduce your risk of injury during operations that require the blade guard be removed from the saw. **ALWAYS** replace the blade guard after dadoing is complete.

### Cutting Rabbets with a Dado Blade

1. DISCONNECT SAW FROM POWER!
2. Adjust dado blade to height needed for rabbeting operation. When cutting deep rabbets, take more than one pass to reduce risk of kickback.
3. Adjust fence and align workpiece to perform cutting operation, as shown in **Figure 70**.

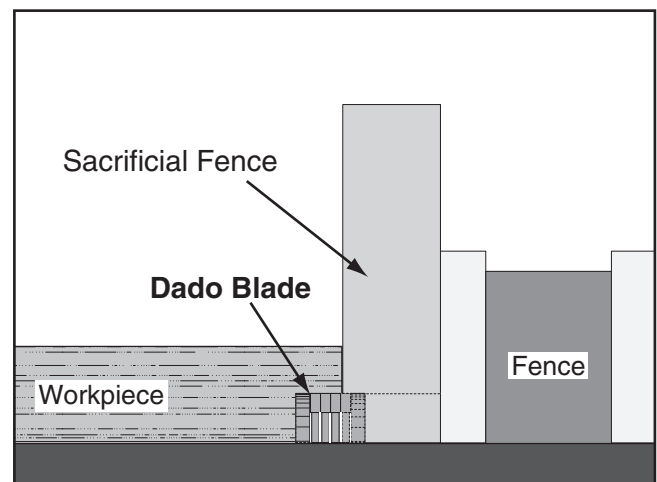

**Figure 70.** Rabbet cutting.

4. Reconnect saw to power source and turn saw ON. When blade has reached full speed, perform a test cut with a scrap piece of wood.  
—If cut is satisfactory, repeat cut with workpiece.



## Cutting Rabbets with a Standard Blade

A ripping blade is typically the best blade to use for cutting rabbets when using a standard blade because it removes sawdust very efficiently. (See **Page 28** for blade details.) Also, a sacrificial fence is not required when cutting rabbets with a standard blade.

### To cut rabbets with a standard blade:

1. DISCONNECT SAW FROM POWER!
2. Ensure that riving knife and standard table insert are installed.
3. Mark width of rabbet cut on edge of workpiece, so you can clearly identify intended cut while it is laying flat on saw table.
4. Raise blade up to desired depth of cut (depth of rabbet channel desired).
5. Stand workpiece on edge, as shown in **Figure 71**, then adjust fence so blade is aligned with inside of your rabbet channel.

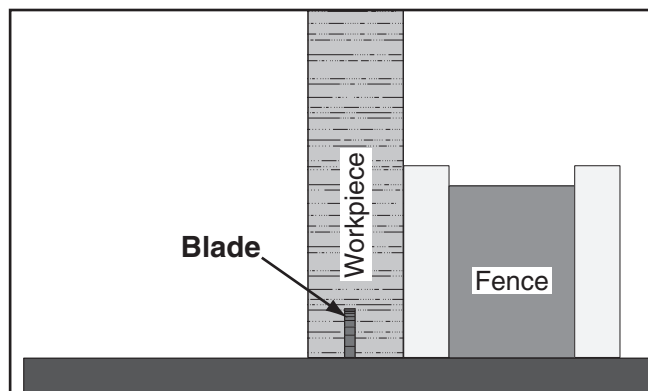
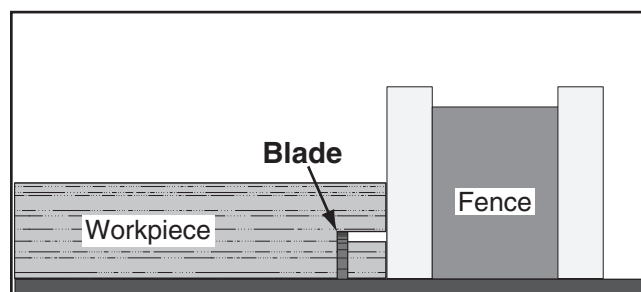

**Figure 71.** Example of rabbet cutting with a standard blade.

—If workpiece is very tall, or is unstable when placed against fence, lay it flat on table and use a dado blade to perform rabbet cut.



6. Reconnect saw to power source, then perform cut.
7. Lay workpiece flat on table, as shown in **Figure 72**, adjust saw blade height to intersect with first cut, then perform second cut to complete rabbet.



**Figure 72.** Example of second cut to create a rabbet.



# Resawing

## **!WARNING**

Resawing operations require proper procedures to avoid serious injury and prevent kickback. Any tilting or movement of workpiece away from fence will likely cause kickback. Be certain that stock is flat and straight. Failure to follow these warnings could result in serious personal injury or amputation.

Resawing is the process of cutting a thick piece of stock into one or more thinner pieces. Although re-sawing can be done with a table saw, we strongly recommend that you use a bandsaw instead.

A bandsaw is the ideal machine for re-sawing, and resawing with one is fairly easy and safe. A table saw is not intended for resawing, and resawing with one is difficult and more dangerous than a bandsaw due to the increased risk of kickback from binding and deep cuts, and the increased risk of injury from having to remove the guard.

If you insist on resawing with a table saw, DO NOT do so without using a resaw barrier and wearing a full face shield. The following instructions describe how to build a resaw barrier and add an auxiliary fence to your standard fence, to reduce the risk injury from resawing on a table saw.

**Note:** To determine the maximum resawing height for this table saw, find the maximum blade height, then double it and subtract  $\frac{1}{8}$ ".

## Making Resaw Barrier

When resawing, the resaw barrier acts in tandem with the rip fence to provide tall support for the workpiece. This minimizes the probability of it binding against the blade and causing kickback.

Tools Needed:	Qty
Table Saw .....	1
Jointer and Planer .....	Recommended
Clamps .....	2 Minimum
Drill .....	1
Drill Bits $\frac{1}{8}$ ", $\frac{9}{64}$ " .....	1 Each
Countersink Bit .....	1

### Components Needed for Resaw Barrier:

Wood* $\frac{3}{4}$ " x $5\frac{1}{2}$ " x Length of Fence .....	1
Wood* $\frac{3}{4}$ " x 3" x Length of Fence .....	1
Wood Screws #8 x 2" .....	4
Wood Glue .....	As Needed

*\*Only use furniture-grade plywood, kiln-dried hardwood, or HDPE plastic to prevent warping.*

### To build a resaw barrier:

1. Cut your wood pieces to size specified above. If you are using hardwood, cut pieces over-size, then joint and plane them to correct size to make sure they are square and flat.
2. Pre-drill and countersink four holes approximately  $\frac{3}{8}$ " from bottom of  $5\frac{1}{2}$ " tall wood piece.
3. Glue end of 3" board, clamp boards at a  $90^\circ$  angle with larger board in vertical position, as shown in **Figure 73**, then fasten together with wood screws.

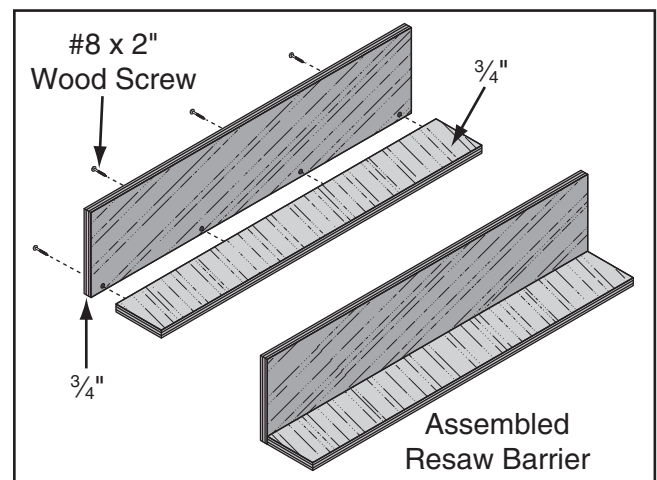

**Figure 73.** Resaw barrier.



## Making Auxiliary Fence

The auxiliary fence is necessary if you are resawing a workpiece that is taller than it is wide. The fence should be no less than 1/2" shorter than the board to be resawn.

**IMPORTANT:** Installation requires permanent modification to the Model G0771 table saw fence—specifically drilling mounting holes.

The fence should be similar to the one in **Figure 74** when installed.

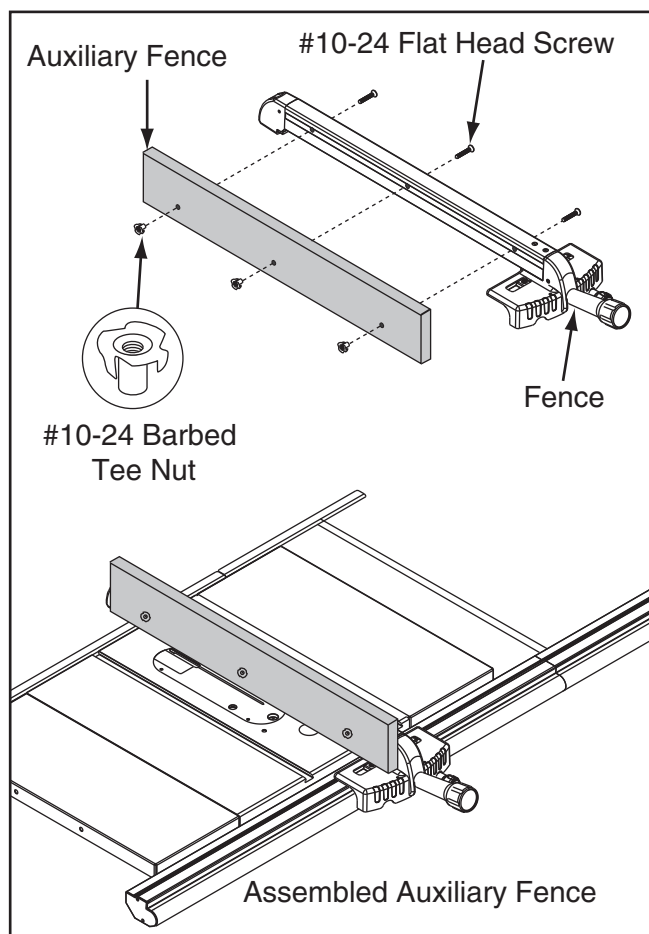

**Figure 74.** Example of auxiliary fence installed on standard fence.

### Tools Needed:

Tools Needed:	Qty
Clamps .....	2 Minimum
Drill .....	1
Drill Bits 1/8", 3/16", 1/4" .....	1 Each
Countersink Drill Bit.....	1
Forstner Bit 3/4".....	1
Mallet.....	1
Phillips Head Screwdriver #2 .....	1
Ruler.....	1

### Components Needed:

Barbed T-nuts #10-24 .....	3
Flat Head Screws #10-24.....	3
Wood* 3/4" x 4" x Length of Fence .....	1
Scrap Board .....	1

\*Only use furniture-grade plywood, kiln-dried hardwood, or HDPE plastic to prevent warping.

### To build an auxiliary fence:

1. Remove fence from table, and mark three holes on both sides of aluminum fence body, as indicated in **Figure 75**.

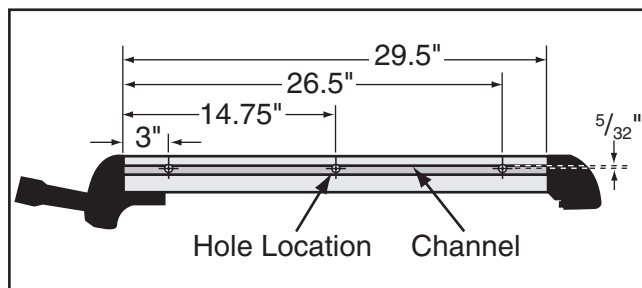

**Figure 75.** Location to mark holes in fence.

**Note:** Make sure holes are located exactly 5/32" below top edge of channel. If you place hole in center of channel, drill bit will run into a support wall.

2. Using a 1/8" drill bit, drill a pilot hole into each hole location, then use a 3/16" bit to drill through fence and connect each pair of holes. Do not drill holes larger than necessary or mounting screws will not pull out.
3. Countersink six holes drilled into aluminum fence, then insert flat head screws through holes. Adjust depth of countersink holes as needed so that heads of flat head screws sit below surface of channel, as illustrated in **Figure 76**.

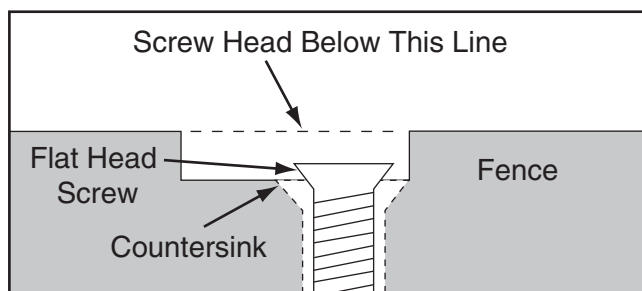

**Figure 76.** Flat head screw below fence channel.



4. Shake aluminum shavings out of fence.
5. Place a thin metal shim (such as a ruler) between table and bottom of auxiliary fence board, so fence will not catch on table when moved.
6. Place a scrap board adjacent to auxiliary fence to reduce tear out, then clamp scrap board and auxiliary fence onto fence, as shown in **Figure 77**.

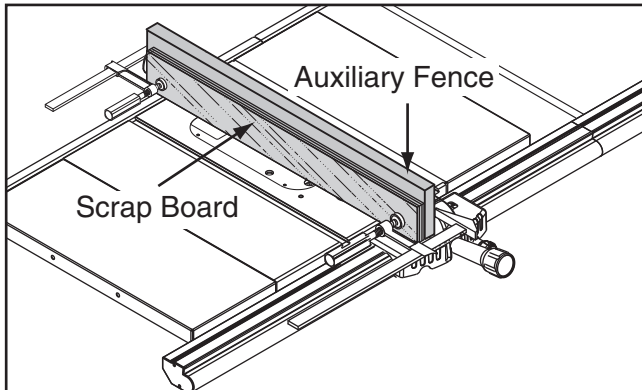

**Figure 77.** Scrap board and auxiliary fence clamped to fence to reduce tearout.

7. Using  $\frac{3}{16}$ " bit, drill through holes in fence into auxiliary fence board, then remove clamps, scrap board and auxiliary fence.
8. Use a  $\frac{3}{4}$ " forstner bit to countersink three holes in auxiliary fence  $\frac{1}{16}$ " deep so T-nuts will be flush with auxiliary fence face in **Step 10**.
9. Clamp scrap board to auxiliary fence, then use a  $\frac{1}{4}$ " drill bit to drill into auxiliary fence for shaft of T-nuts.
10. Using a mallet, tap each T-nut into one of the holes in auxiliary fence.
11. Insert a flat head screw through each hole in fence, then thread them into the T-nuts. The end result should appear similar to **Figure 74** on **Page 42**.
12. Slide a flat piece of wood across auxiliary fence and fence to verify mounting hardware is correctly installed. Adjust fasteners so they do not catch on workpieces.

## Resawing Operations

The table saw motor is pushed to its limits when resawing. If the motor starts to bog down, slow down your feed rate. Motor overloading and blade wear can be reduced by using a ripping blade. Ripping blades are designed to clear the sawdust quickly.

### Components Needed for Resawing:

Zero-Clearance Insert .....	1
Ripping Blade 10" .....	1
Clamps .....	2
Shop-Made Auxiliary Fence .....	1
Shop-Made Resaw Barrier .....	1

## **!WARNING**

You may experience kickback during this procedure. Stand to the side of the blade and wear safety glasses and a full face shield to prevent injury when resawing.

### To perform resawing operations:

1. DISCONNECT SAW FROM POWER!
2. Remove standard table insert and blade guard assembly.
3. Install a ripping blade, install riving knife, lower blade below table surface, then install zero-clearance table insert.
4. Attach auxiliary fence and set it to desired width.

**Note:** When determining correct width, don't forget to account for blade kerf and inaccuracy of fence scale while auxiliary fence is installed.



- Place workpiece against auxiliary fence and slide resaw barrier against workpiece, as shown in **Figure 83**. Now clamp resaw barrier to top of table saw at both ends.

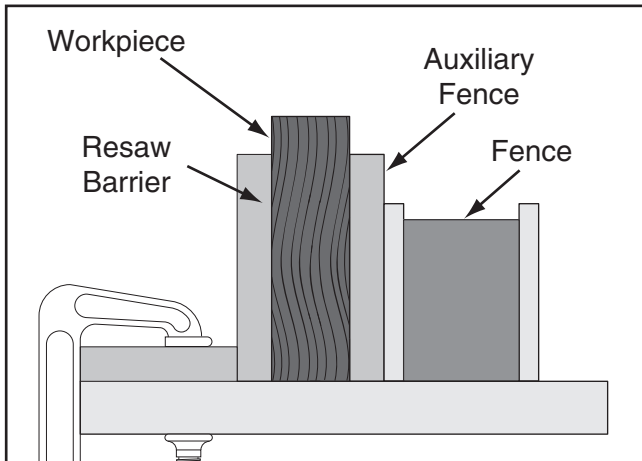

**Figure 83.** Ideal resaw workpiece setup.

- Lower blade completely below table-top, and slide workpiece over blade to make sure it moves smoothly and fits between resaw barrier and fence.
- Raise blade approximately an inch, or close to half the height of workpiece (see **Figure 84**), whichever is less.

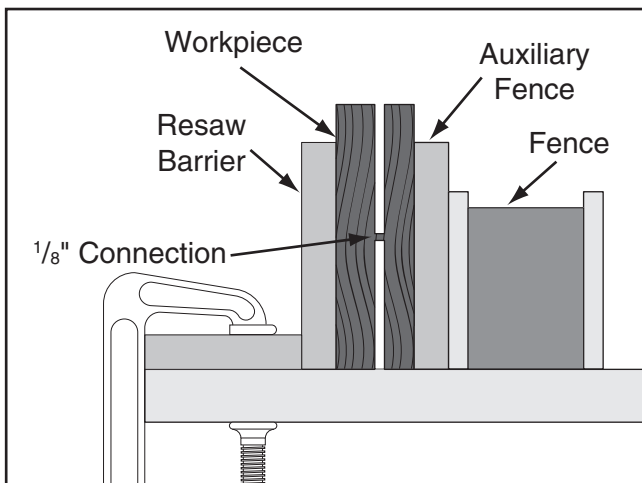

**Figure 84.** Ideal completed resaw cut.

## **!WARNING**

The danger of kickback increases relative to the depth of a cut. Reduce the risk of kickback by making multiple passes to achieve the desired depth of cut. Failure to follow these warnings could result in serious personal injury.

## **!WARNING**

Always use push sticks or push paddles to increase safety and control during operations which require that the blade guard and spreader must be removed from the saw. **ALWAYS** replace the blade guard after resawing is complete.

- Plug in table saw, turn it **ON**, and use a push stick or push block to feed workpiece through blade, using a slow and steady feed rate.
 

**Note:** We recommend making a series of light cuts that get progressively deeper, to reduce the chance of stalling the motor.
- Flip workpiece end for end, keeping same side against fence, and run workpiece through blade.
- Repeat **Steps 7–9** until blade is close to half the height of board to be resawn. The ideal completed resaw cut will leave an  $\frac{1}{8}$ " connection when resawing is complete as shown in **Figure 84**. Leaving an  $\frac{1}{8}$ " connection will reduce risk of kickback.
- Turn **OFF** table saw, then separate parts of workpiece and hand plane remaining ridge to remove it.
- When finished resawing, remove resaw barrier and auxiliary fence, then re-install blade guard/spreader or riving knife and standard table insert.



# SECTION 5: SHOP MADE SAFETY ACCESSORIES

## Featherboards

Easily made from scrap stock, featherboards provide an added degree of protection against kickback, especially when used together with push sticks. They also maintain pressure on the workpiece to keep it against the fence or table while cutting, which makes the operation easier and safer because the cut can be completed without the operator's hands getting near the blade. The angled ends and flexibility of the fingers allow the workpiece to move in only one direction.

### Making a Featherboard

This sub-section covers the two basic types of featherboards: 1) Those secured by clamps, and 2) those secured with the miter slot.

#### Material Needed for Featherboard

Hardwood  $\frac{3}{4}$ " x 3" x 10" (Minimum)  
Hardwood  $\frac{3}{4}$ " x 6" x 28" (Maximum) ..... 1

#### Additional Material Needed for Mounting Featherboard in Miter Slot

Hardwood  $\frac{3}{8}$ " x (Miter Slot Width) x 5" L ..... 1  
Wing Nut  $\frac{1}{4}$ "-20..... 1  
Flat Head Screw  $\frac{1}{4}$ "-20 x 2" ..... 1  
Flat Washer  $\frac{1}{4}$ "-20..... 1

#### To make a featherboard:

1. Cut a hardwood board approximately  $\frac{3}{4}$ " thick to size. Length and width of board can vary according to your design. Most featherboards are 10"–28" long and 3"–6" wide. Make sure wood grain runs parallel with length of featherboard, so fingers you will create in **Step 3** will bend without breaking.
2. Cut a 30° angle at one end of board.

## CAUTION

We recommend using a bandsaw for making fingers in the next step because it tends to be safer. A table saw can be used, but it will over-cut the underside of the ends, produce a thicker kerf, and require you to stop the blade half-way through the cut, which can be dangerous.

3. Make a series of end cuts with the grain  $\frac{3}{8}$ "– $\frac{1}{4}$ " apart and 2"–3" long, as shown in **Figure 85 (A)**. Alternatively, start cuts at 2"-3" deep, then make them progressively deeper, as shown in **Figure 85 (B)**.

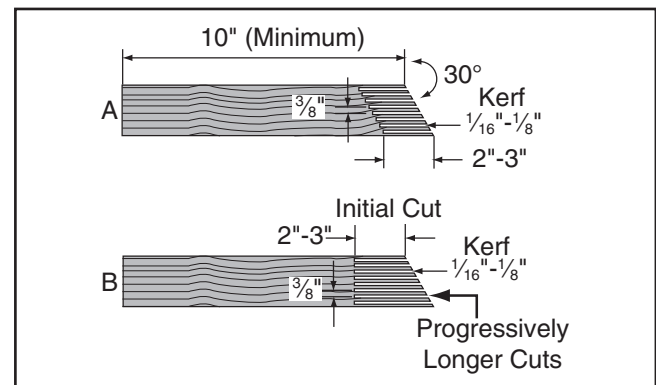

**Figure 85.** Patterns for featherboards (top view shown).

**IMPORTANT:** Cuts made across grain result in weak fingers that easily break when flexed. When made correctly, fingers should withstand flexing from moderate pressure. To test finger flexibility, push firmly on ends with your thumb. If fingers do not flex, they are likely too thick (cuts are too far apart).

## NOTICE

Only Steps 1–3 are required to make a clamp-mounted featherboard. Refer to Page 45 for instructions on clamping.



4. Rout a  $\frac{1}{4}$ "– $\frac{3}{8}$ " wide slot 4"–5" long in workpiece and 1"–2" from short end of featherboard (see **Figure 78**).

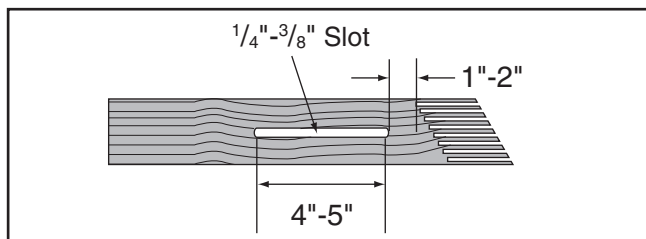

**Figure 78.** Slot routed in featherboard.

5. Cut a miter bar approximately 5" long that will fit in table miter slot, as shown in **Figure 79**.

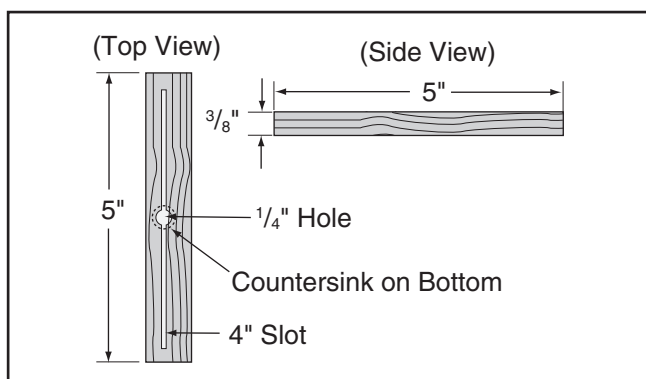

**Figure 79.** Miter bar pattern.

**Tip:** Consider making miter bar longer for larger featherboards—approximately half the length of total featherboard—to support force applied to the featherboard during use.

6. Drill a  $\frac{1}{4}$ " hole in center of bar, then countersink bottom to fit a  $\frac{1}{4}$ "-20 flat head screw.

7. Mark a 4" line through center of countersunk hole in center, then use a jig saw with a narrow blade to cut it out.

8. Assemble miter bar and featherboard with a  $\frac{1}{4}$ "-20 x flat head screw, flat washer, and a wing nut or a star knob (see **Figure 80**). Congratulations! Your featherboard is complete.

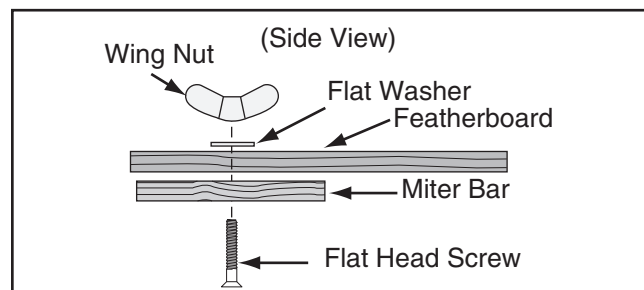

**Figure 80.** Assembling miter slot featherboard components.

**Note:** The routed slot, countersink hole, and flat head screw are essential for miter bar to clamp into miter slot. When wing nut is tightened, it will draw flat head screw upward into countersunk hole. This will spread sides of miter bar and force them into walls of miter slot, locking featherboard in place.

**Tip:** The length of the flat head screw depends on thickness of featherboard—though  $1\frac{1}{2}$ " to 2" lengths usually work.

Now, proceed to **Mounting Featherboard in Miter Slot** on **Page 45**.





## Mounting Featherboards w/Clamps

1. Lower saw blade, then adjust fence to desired width and secure it.
2. Place workpiece against fence, making sure it is 1" in front of the blade.
3. Place a featherboard on table away from blade so all fingers point forward and contact workpiece (see **Figure 81**).

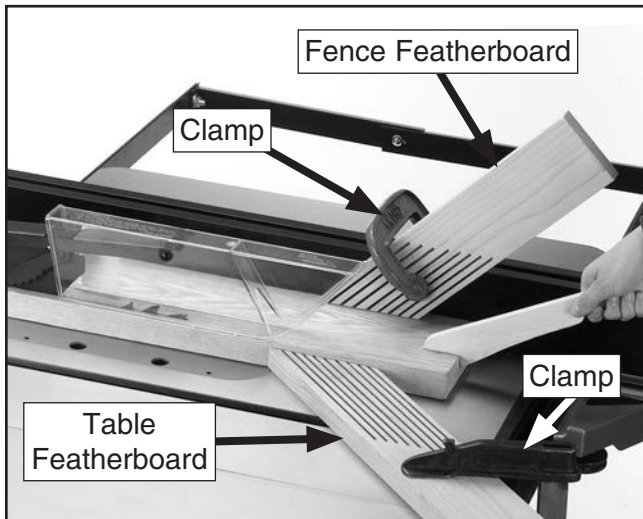
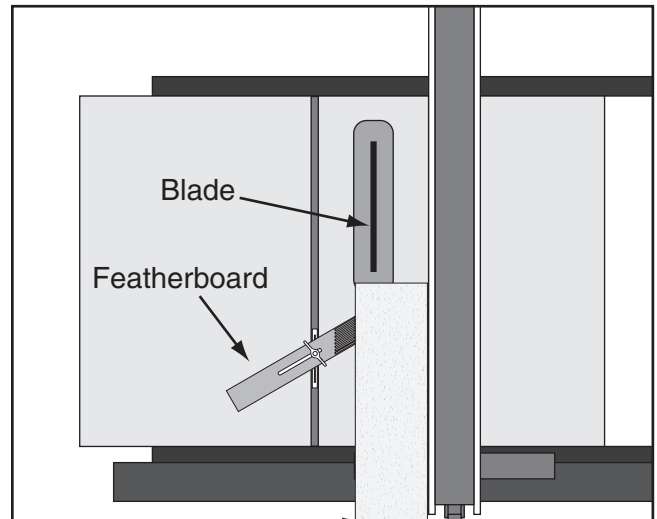

**Figure 81.** Example of featherboards secured with clamps.

4. Secure featherboard to table with a clamp.
5. Check featherboard by pushing it with your thumb to ensure it is secure.  
—If featherboard moves, tighten clamp more.
6. Optional: If cutting long workpieces, it may be beneficial to use another featherboard to keep board firmly against table while feeding.

## Mounting Featherboard in Miter Slot

1. Lower saw blade, then adjust fence to desired width and secure it.
2. Place workpiece evenly against fence, making sure it is 1" in front of blade.
3. Slide featherboard miter bar into miter slot, making sure fingers slant toward blade, as shown in **Figure 82**.



**Figure 82.** Featherboard installed in miter slot and supporting workpiece for ripping cut.

4. Position fingered edge of featherboard against edge of workpiece, so that all fingers contact workpiece. Slide featherboard toward blade until first finger is nearly even with end of workpiece, which should be 1" away from blade.
5. Double check workpiece and featherboard to ensure they are properly positioned, as described in **Step 4**. Then secure featherboard to table. Check featherboard by hand to make sure it is tight.

**Note:** *The featherboard should be placed firmly enough against workpiece to keep it against fence but not so tight that it is difficult to feed workpiece.*



# Push Sticks

When used correctly, push sticks reduce the risk of injury by keeping hands away from the blade while cutting. In the event of an accident, a push stick can also absorb damage that would have otherwise happened to hands or fingers.

## Using a Push Stick

Use push sticks whenever your hands will get within 12" of the blade. To maintain control when cutting large workpieces, start the cut by feeding with your hands then use push sticks to finish the cut, so your hands are not on the end of the workpiece as it passes through the blade.

**Feeding:** Place the notched end of the push stick against the end of the workpiece (see **Figure 88** below), and move the workpiece into the blade with steady downward and forward pressure.

**Supporting:** A second push stick can be used to keep the workpiece firmly against the fence while cutting. When using a push stick in this manner, only apply pressure before the blade; otherwise, pushing the workpiece against or behind the blade will increase the risk of kickback (see "Push Stick Prohibition Zone" in **Figure 86** below).

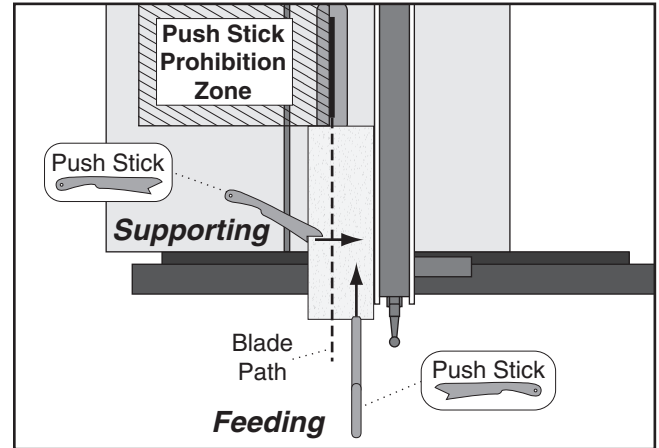

**Figure 86.** Using push sticks to rip narrow stock.

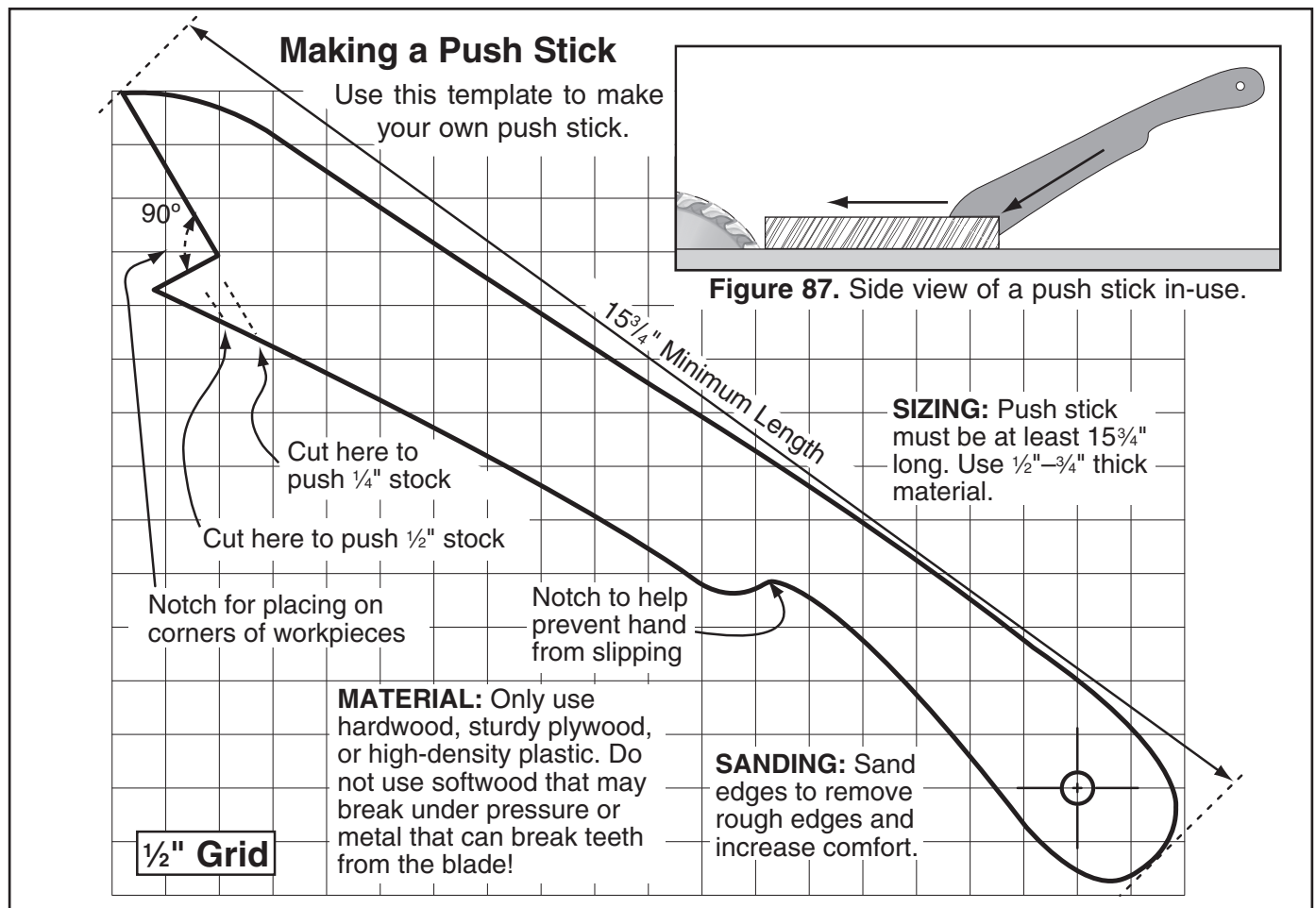

**Figure 88.** Template for a basic shop-made push stick (not shown at actual size).

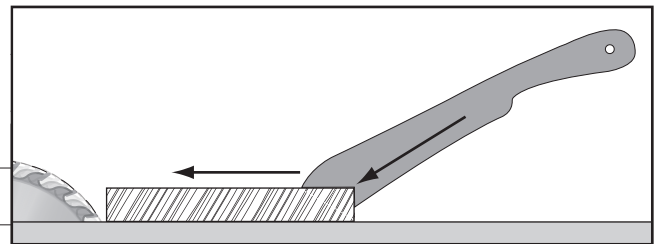

**Figure 87.** Side view of a push stick in-use.



# Push Blocks

When used correctly, a push block reduces the risk of injury by keeping hands away from the blade while cutting. In the event of an accident, a push block often takes the damage that would have otherwise happened to hands or fingers.

## Using a Push Block

A push block can be used in place of or in addition to a push stick for feeding workpieces into the blade. Due to their design, push blocks allow the operator to apply firm downward pressure on the workpiece that could not otherwise be achieved with a push stick.

The push block design on this page can be used in two different ways (see **Figure 89** below). Typically, the bottom of the push block is used until the end of the workpiece reaches the blade.

The notched end of the push block is then used to push the workpiece the rest of the way through the cut, keeping the operator's hands at a safe distance from the blade. A push stick is often used at the same time in the other hand to support the workpiece during the cut (see **Using a Push Stick** on previous page).

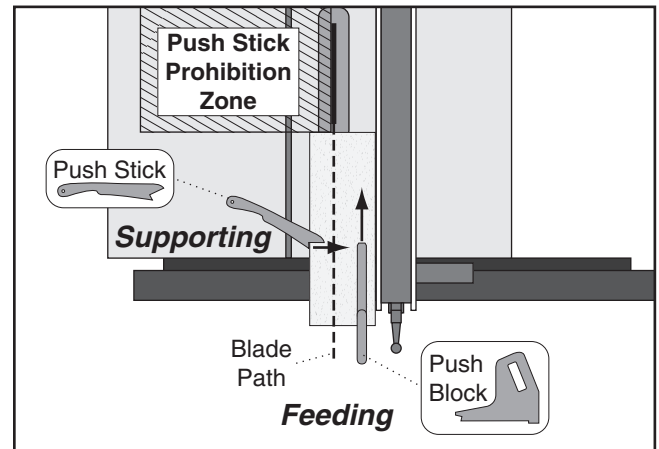

**Figure 90.** Using a push block and push stick to make a rip cut.

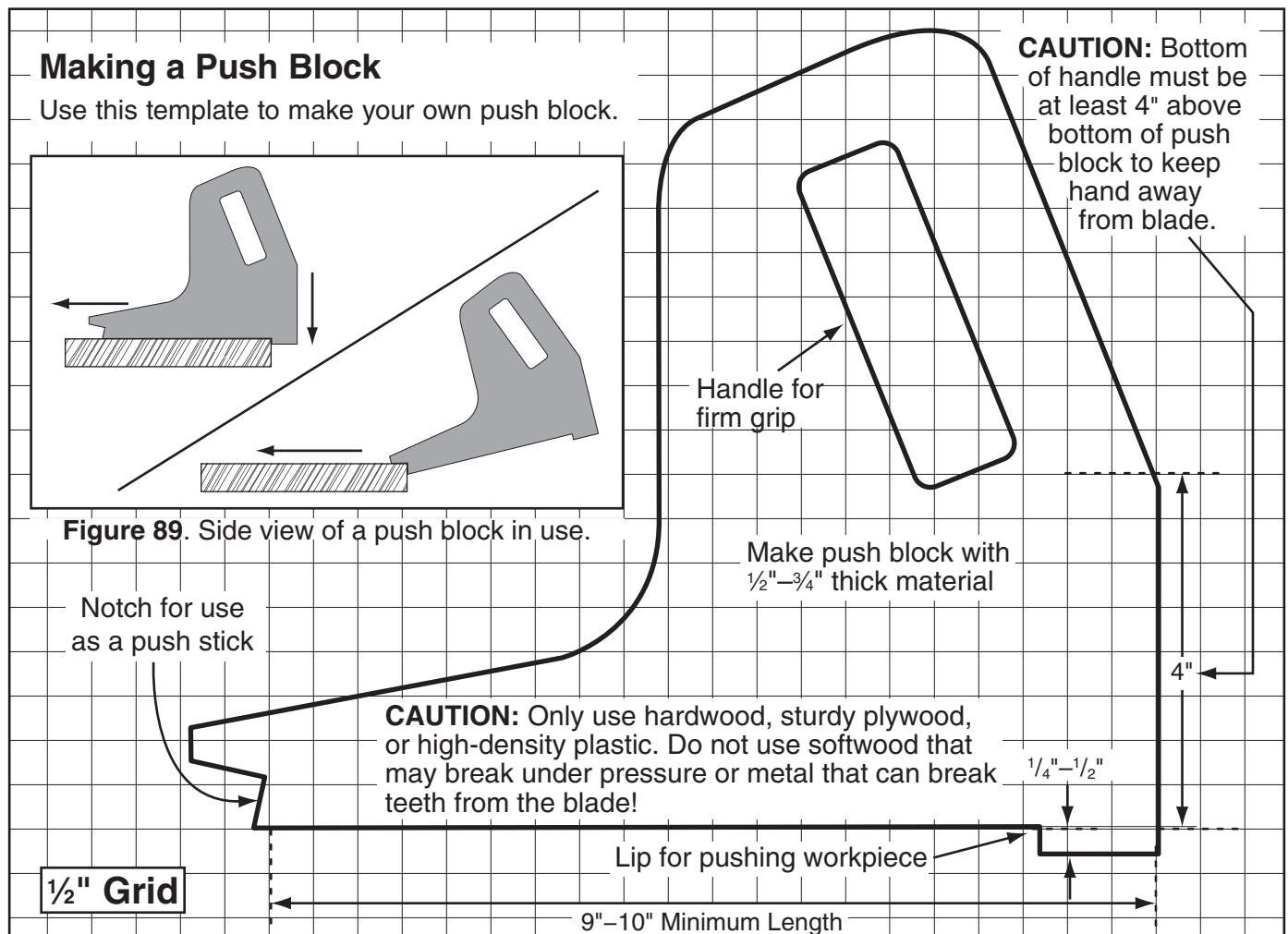

**Figure 91.** Template for a shop-made push block (shown at 50% of full size).



# Narrow-Rip Auxiliary Fence & Push Block

There are designs for hundreds of specialty jigs that can be found in books, trade magazines, and on the internet. These types of jigs can greatly improve the safety and consistency of cuts. They are particularly useful during production runs when dozens or hundreds of the same type of cut need to be made.

The narrow-rip auxiliary fence and push block system shown in this section is an example of a specialty jig that can be made to increase the safety of very narrow rip cuts.

## Material Needed for Narrow Rip Auxiliary Fence & Push Block

Hardwood  $\frac{3}{4}$ " x 3" x Length of Fence ..... 1  
 Plywood  $\frac{3}{4}$ " x  $5\frac{1}{4}$ " x Length of Fence ..... 1  
 Wood Screws #8 x  $1\frac{1}{2}$ " ..... 8

## Material Needed for Push Block

Hardwood or Plywood  $\frac{3}{4}$ " x 15" x  $5\frac{5}{8}$ " ..... 1  
 Hardwood or Plywood  $\frac{3}{4}$ " x 10" x 5"–9" ..... 1  
 Cyanoacrylate Wood Glue ..... Varies  
 Wood Screws #8 x  $1\frac{1}{2}$ " ..... As Needed

## Making a Narrow-Rip Push Block for an Auxiliary Fence

1. Cut a piece of  $\frac{3}{4}$ " thick plywood  $5\frac{1}{4}$ " wide and as long as your table saw fence; cut a piece of  $\frac{3}{4}$ " thick hardwood 3" wide and as long as your table saw fence, as shown in **Figure 92**.

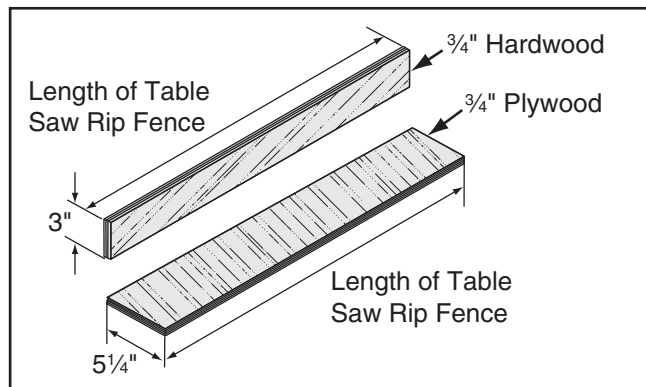

**Figure 92.** Auxiliary fence dimensions.

**Note:** We recommend cutting hardwood board oversize, then jointing and planing it to correct size to make sure board is square and flat. Only use furniture-grade plywood or kiln-dried hardwood to prevent warping.

2. Pre-drill and countersink eight pilot holes  $\frac{3}{8}$ " from bottom of 3" wide board, then secure boards together with eight #8 x  $1\frac{1}{2}$ " wood screws, as shown in **Figure 93**.

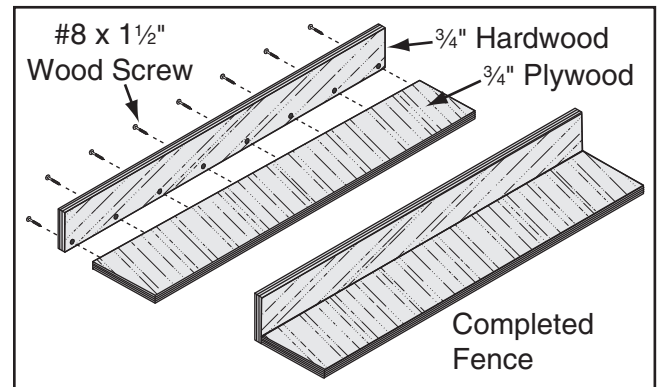

**Figure 93.** Location of pilot holes.

3. Using  $\frac{3}{4}$ " material you used in previous steps, cut out pieces for push block per dimensions shown in **Figure 94**; for handle, cut a piece 10" long by 5"–9" high and shape it as desired to fit your hand.

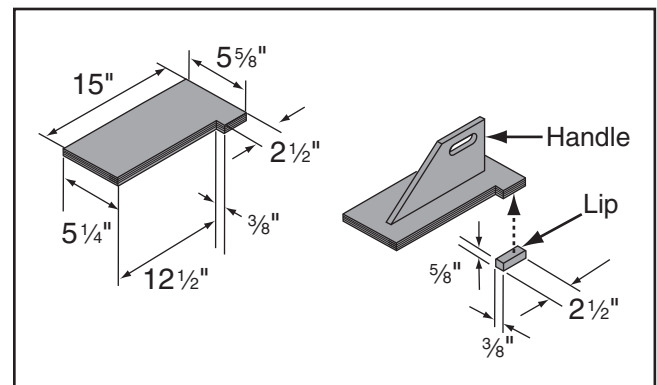

**Figure 94.** Push block dimensions and construction.

4. Attach handle to base with #8 x  $1\frac{1}{2}$ " wood screws, and attach lip to base with cyanoacrylate-type wood glue.



## Using the Auxiliary Fence & Push Block

1. Place auxiliary fence on table and clamp it to fence at both ends, then adjust distance between auxiliary fence and blade—this determines how wide workpiece will be ripped (see **Figure 95**).

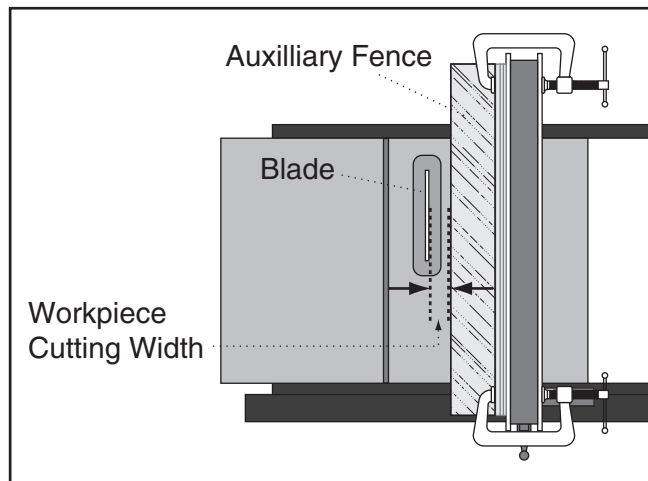

**Figure 95.** Adjusting ripping distance between blade and auxiliary fence.

2. Install blade guard, then remove right spreader pawl, as explained on **Page 32**, so it does not interfere with push block lip.

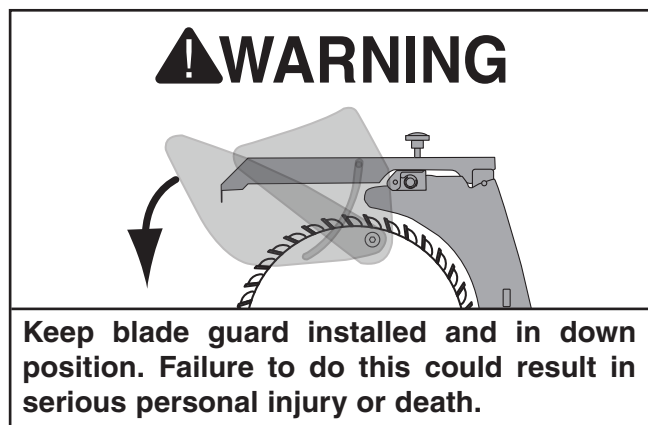

**Keep blade guard installed and in down position. Failure to do this could result in serious personal injury or death.**

3. Place workpiece 1" behind blade and evenly against table and auxiliary fence.

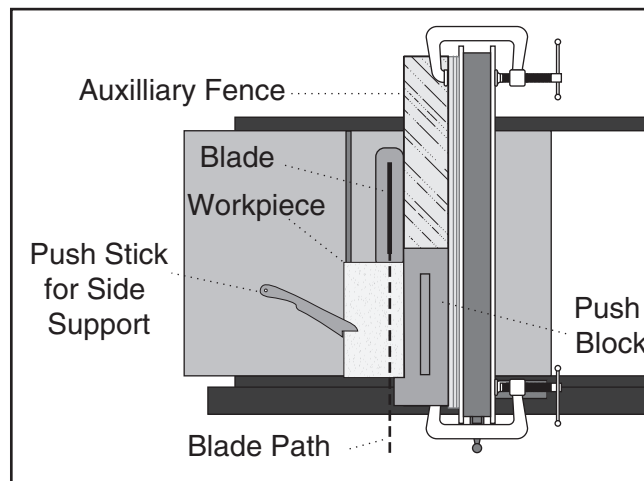

**Figure 96.** Push block in position to push workpiece through blade.

4. Turn saw **ON**, then begin ripping workpiece using a push stick for side support.
5. As workpiece nears end of cut, place push block on auxiliary fence with lip directly behind workpiece, then release push stick just before blade.
6. Guide workpiece rest of way through cut with push block, as shown in **Figure 97**.

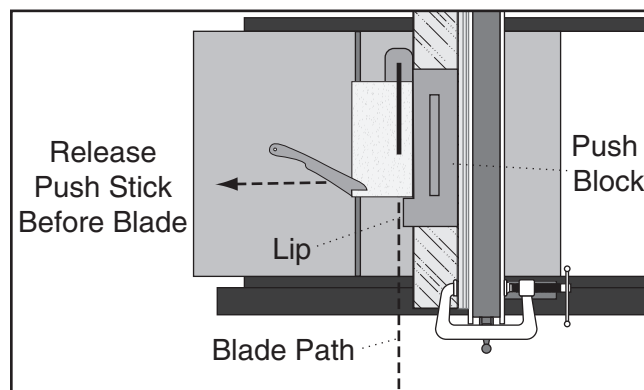

**Figure 97.** Ripping with push block.

## ! WARNING

**Turn OFF the saw and allow blade to come to a complete stop before removing cut-off piece. Failure to follow this warning could result in serious personal injury.**

7. Re-install spreader pawls when finished using auxiliary fence and push block.



# Outfeed & Support Tables

---

One of the best accessories for improving the safety and ease of using a table saw is simply placing a large table (outfeed table) behind the saw to catch the workpiece (see **Figure 98**). Additionally, another table to the left of the saw (support table) can also help support large workpieces so they can be cut safely and accurately.



**Figure 98.** Example of outfeed & support tables.

# Crosscut Sled

---

A crosscut sled (see **Figure 99**) is a fantastic way to improve the safety and accuracy of crosscutting on the table saw. Most expert table saw operators use a crosscut sled when they have to crosscut a large volume of work, because the sled offers substantial protection against kickback when crosscutting.



**Figure 99.** Example of crosscut sled.



# SECTION 6: ACCESSORIES

## ⚠ WARNING

Installing unapproved accessories may cause machine to malfunction, resulting in serious personal injury or machine damage. To reduce this risk, only install accessories recommended for this machine by Grizzly.

## NOTICE

Refer to our website or latest catalog for additional recommended accessories.

### D2075A—Heavy-Duty Mobile Base

Most stable mobile base on the market. With heavy-duty casters arranged on outriggers, machine sits as low as possible, for maximum stability. Adjusts from 20" x 20" to 29½" x 29½".

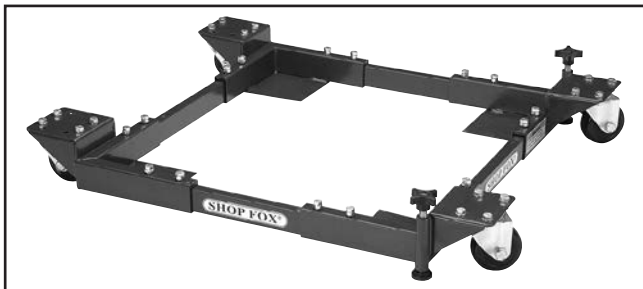

Figure 100. D2075A Heavy-Duty Mobile Base.

### G1317—Outfeed Roller System For Table Saws

Supports work approx. 48" beyond blade. Folds down easily and snaps up quickly without tools. Double level system lets you set the rollers either in-line with the table or slightly below it.

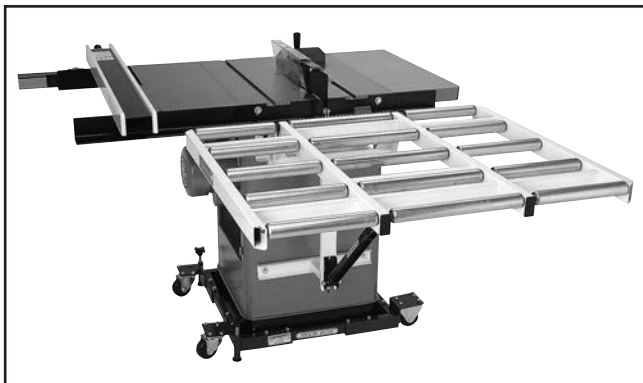

Figure 101. G1317 Outfeed Roller System.

### G1163P—1HP Floor Model Dust Collector

### G0710—1HP Wall-Mount Dust Collector

### H4340—3.0 Micron Upgrade Bag

Excellent point-of-use dust collectors that can be used next to the machine with only a small amount of ducting. Specifications: 450 CFM, 7.2" static pressure, 2 cubic foot bag, and 30 micron filter. Motor is 1HP, 110V/220V, 14A/7A.



Figure 102. Point-of-use dust collectors.

### D4206—Clear Flexible Hose 4" x 10'

### W1034—Heavy-Duty Clear Flex Hose 4" x 10'

### W1015—Y-Fitting 4" x 4" x 4"

### W1017—90° Elbow 4"

### W1019—Hose Coupler (Splice) 4"

### W1317—Wire Hose Clamp 4"

### W1007—Plastic Blast Gate 4"

### W1053—Anti-Static Grounding Kit

We've hand picked a selection of commonly used dust collection components for machines with 4" dust ports.



Figure 103. Dust collection accessories.

order online at [www.grizzly.com](http://www.grizzly.com) or call 1-800-523-4777



### Forrest Dado Blades

**H4756—8", 24 Teeth, 1/4"—29/32" Groove**

**T23267—8", 24 Teeth, 3/16"—1/4" Groove**

The world's finest dado head cleancuts all your grooves! No splintering when cross-cutting oak, ply veneers and melamine. Perfect for flat-bottomed grooves. No staggered steps or round bottoms like a wobble-dado leaves! Cuts in all directions - rip, cross-cut, miter, any depth. Cuts all sized grooves 1/4" through 29/32" increments.



Figure 104. H4756 Dado Blade.

### Forrest Woodworker II Saw Blades

**T20778—10", 20 Teeth**

**T20779—10", 40 Teeth**

**T23527—10", 48 Teeth**

Hailed as the Cadillac of all blades, Forrest saw blades have become legendary for their ability to leave highly polished, finish ready surfaces on nearly everything they cut. Made in USA.

With this all purpose blade for table saws you can rip and crosscut 1" 2" rockhards and softwoods, resulting in a smooth as sanded surface. With 20° face hook, ply veneers will crosscut with no bottom splinter at moderate feed rates. Double hard and 40% stronger C4 carbide will give up to 300% longer life between sharpenings. Ends blade changing (one blade does rip, combo and crosscut), second-step finishing and cutting 1/16" oversize to allow for resurfacing. Buy and sharpen one blade instead of 3 (24T rip, 50T combination and 80T crosscut). 5/8" arbor, 1/8" kerf.



Figure 105. Forrest Woodworker II Saw Blade.

**G5562—SLIPIT® 1 Qt. Gel**

**G5563—SLIPIT® 12 oz Spray**

**G2871—Boeshield® T-9 12 oz Spray**

**H3788—G96® Gun Treatment 12 oz Spray**

**H3789—G96® Gun Treatment 4.5 oz Spray**



Figure 106. Recommended products for protecting your cast iron table top.

### H8029—5 Pc. Safety Kit

Comes with four table saw jigs, essential for safe operation. Includes two push blocks, push stick, featherboard, and combination saw and router gauge. Featherboard fits 3/8" x 3/4" miter slots.

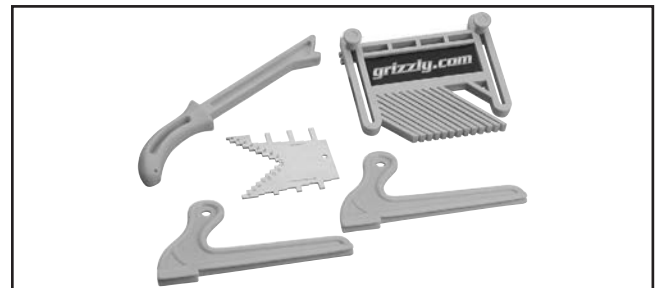

Figure 107. H8029 5 Pc. Safety Kit.

### D3096—Featherboard

Reduce the risk of kick-back without the use of clamps. These featherboards are designed to lock into 3/8" and 3/4" miter gauge slots and are adjustable for various stock widths.

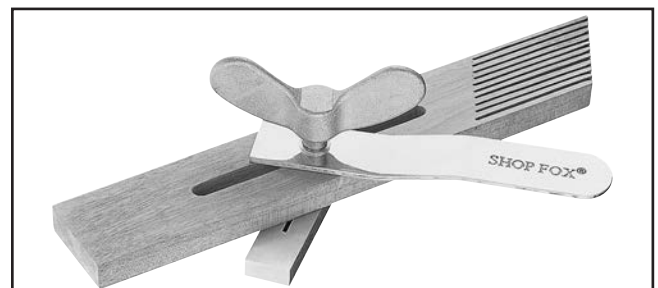

Figure 108. D3096 Featherboard.





# SECTION 7: MAINTENANCE

---

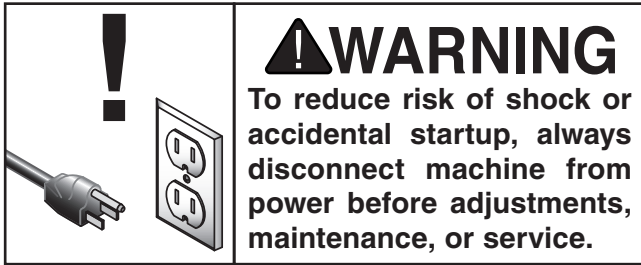

---

## Schedule

---

For optimum performance from your machine, follow this maintenance schedule and refer to any specific instructions given in this section.

### Daily Check:

- Loose mounting bolts.
- Damaged saw blade.
- Worn or damaged wires.
- Any other unsafe condition.

### Weekly Maintenance:

- Clean sliding table surface and grooves.
- Clean and protect cast iron table.
- Clean rip fence and slide ways.

### Monthly Maintenance:

- Clean/vacuum dust buildup from inside cabinet and off motors.
- Check/replace belt for proper tension, damage or wear (**Page 68**).

### Every 6–12 Months:

- Lubricate trunnion slides (**Page 56**).
- Lubricate worm gear (**Page 56**).
- Lubricate leadscrew (**Page 56**).

---

## Cleaning & Protecting

---

Cleaning the saw is relatively easy. Vacuum excess wood chips and sawdust, and wipe off the remaining dust with a dry cloth. If any resin has built up, use a resin-dissolving cleaner to remove it.

Protect the unpainted cast iron table by wiping it clean after every use—this ensures moisture from wood dust does not remain on the bare metal surface. Keep the table rust-free with regular applications of products like G96® Gun Treatment, SLIPIT®, or Boeshield® T-9 (see **Page 54** for more details).



# Lubrication

It is essential to clean components before lubricating them because dust and chips build up on lubricated components and make them hard to move. Simply adding more grease to them will not yield smooth moving components.

Clean the components in this section with mineral spirits or other oil/grease solvent cleaner and shop rags.

If you thoroughly clean the components in this section before lubricating them, the result will be silky smooth movement when turning the handwheels, which will result in much higher enjoyment on your part!

**The following are the main components that need to be lubricated:**

- Trunnion Slides and Orientation Gears
- Worm Gears, Trunnion, and Bearing Housing Teeth

## Trunnion Slides

Clean out the front and rear trunnion slides with mineral spirits and a rag, then apply lithium grease into each groove. Move the blade tilt back-and-forth to spread the grease (see **Figure 109**).

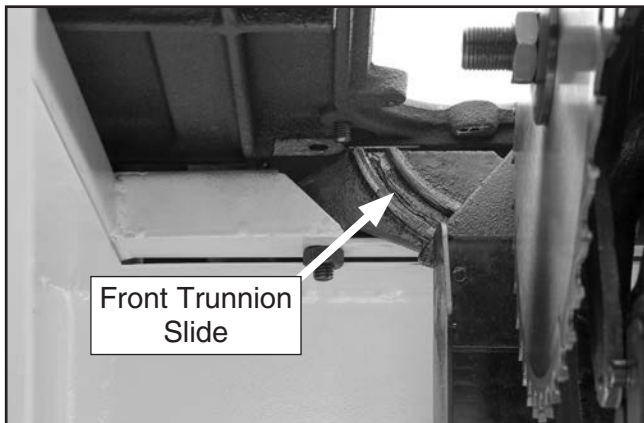

**Figure 109.** Trunnion slide (only front slide shown).

## Worm Gear, Bull Gear & Leadscrew

Clean away any built up grime and debris from the worm gear, bull gear, and leadscrew (see **Figures 110–111**) with a wire brush, rags, and mineral spirits. Allow the components to dry, then apply a thin coat of white lithium grease.

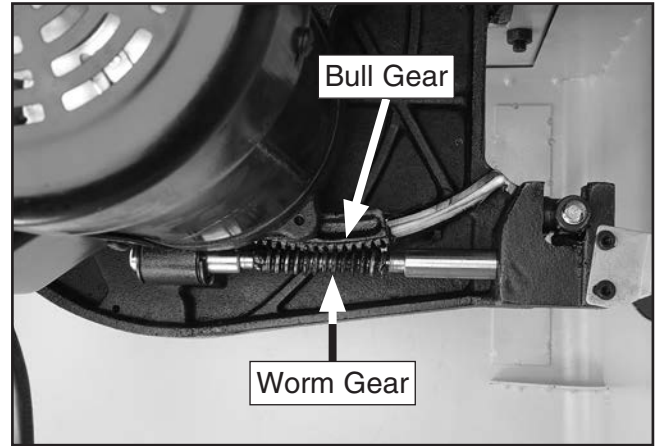

**Figure 110.** Worm and bull gear.

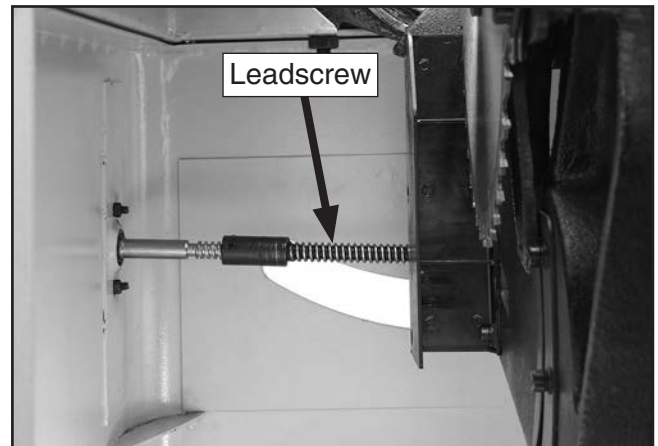

**Figure 111.** Leadscrew.



# SECTION 8: SERVICE

Review the troubleshooting and procedures in this section to fix or adjust your machine if a problem develops. If you need replacement parts or you are unsure of your repair skills, then feel free to call our Technical Support at (570) 546-9663.

## Troubleshooting

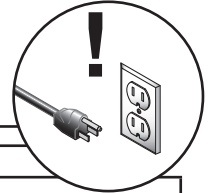

Symptom	Possible Cause	Possible Solution
Machine does not start or a breaker trips.	<ol style="list-style-type: none"> <li>1. Switch disabling key not installed.</li> <li>2. Blown fuse.</li> <li>3. Wall circuit breaker tripped.</li> <li>4. Power supply switched OFF or at fault.</li> <li>5. Plug/receptacle at fault/wired wrong.</li> <li>6. Motor connection wired wrong.</li> <li>7. Wiring open/has high resistance.</li> <li>8. Motor ON/OFF switch at fault.</li> <li>9. Start capacitor at fault.</li> <li>10. Motor at fault.</li> </ol>	<ol style="list-style-type: none"> <li>1. Insert switch disabling key into ON/OFF switch.</li> <li>2. Replace fuse/ensure no shorts.</li> <li>3. Ensure circuit size is correct/replace weak breaker.</li> <li>4. Ensure power supply is on/has correct voltage.</li> <li>5. Test for good contacts; correct the wiring.</li> <li>6. Correct motor wiring connections.</li> <li>7. Check/fix broken, disconnected, or corroded wires.</li> <li>8. Replace switch.</li> <li>9. Test/replace if faulty.</li> <li>10. Test/repair/replace.</li> </ol>
Machine stalls or is underpowered.	<ol style="list-style-type: none"> <li>1. Feed rate/cutting speed too fast.</li> <li>2. Workpiece material unsuitable for machine.</li> <li>3. Workpiece crooked; fence mis-adjusted.</li> <li>4. Machine undersized for task; wrong blade.</li> <li>5. Run capacitor at fault.</li> <li>6. Belt slipping.</li> <li>7. Motor wired incorrectly.</li> <li>8. Plug/receptacle at fault.</li> <li>9. Pulley/sprocket slipping on shaft.</li> <li>10. Motor bearings at fault.</li> <li>11. Contactor not energized/has poor contacts.</li> <li>12. Motor overheated.</li> <li>13. Motor at fault.</li> </ol>	<ol style="list-style-type: none"> <li>1. Decrease feed rate/cutting speed.</li> <li>2. Only cut wood; ensure moisture is below 20%.</li> <li>3. Straighten or replace workpiece; adjust fence.</li> <li>4. Use correct blade; reduce feed rate or depth of cut.</li> <li>5. Test/repair/replace.</li> <li>6. Tension/replace belt (<b>Page 68</b>).</li> <li>7. Wire motor correctly.</li> <li>8. Test for good contacts/correct wiring.</li> <li>9. Replace loose pulley/shaft.</li> <li>10. Test/repair/replace.</li> <li>11. Test all legs for power/replace if faulty.</li> <li>12. Clean motor, let cool, and reduce workload.</li> <li>13. Test/repair/replace.</li> </ol>
Machine has vibration or noisy operation.	<ol style="list-style-type: none"> <li>1. Motor or component loose.</li> <li>2. Blade at fault.</li> <li>3. Belts worn or loose.</li> <li>4. Pulley loose.</li> <li>5. Motor mount loose/broken.</li> <li>6. Machine incorrectly mounted.</li> <li>7. Arbor pulley loose.</li> <li>8. Arbor bearings at fault.</li> <li>9. Motor bearings at fault.</li> </ol>	<ol style="list-style-type: none"> <li>1. Inspect/replace damaged bolts/nuts, and re-tighten with thread locking fluid.</li> <li>2. Replace warped/bent blade; sharpen dull blade.</li> <li>3. Tension/replace belt (<b>Page 68</b>).</li> <li>4. Realign/replace shaft, pulley, setscrew, and key.</li> <li>5. Tighten/replace.</li> <li>6. Tighten mounting bolts; relocate/shim machine.</li> <li>7. Retighten/replace arbor pulley.</li> <li>8. Replace arbor housing bearings; replace arbor.</li> <li>9. Test by rotating shaft; grinding/loose shaft requires bearing replacement.</li> </ol>



Symptom	Possible Cause	Possible Solution
Rip fence does not move smoothly.	<ol style="list-style-type: none"> <li>1. Rip fence mounted incorrectly.</li> <li>2. Rails dirty or sticky.</li> <li>3. Clamp screw is out of adjustment.</li> </ol>	<ol style="list-style-type: none"> <li>1. Remount rip fence.</li> <li>2. Clean and wax rails.</li> <li>3. Adjust clamp screw.</li> </ol>
Rip fence does not lock at rear.	<ol style="list-style-type: none"> <li>1. Clamp screw out of adjustment.</li> </ol>	<ol style="list-style-type: none"> <li>1. Adjust clamp screw.</li> </ol>
Material moves away from fence when ripping.	<ol style="list-style-type: none"> <li>1. Rip fence misaligned.</li> </ol>	<ol style="list-style-type: none"> <li>1. Check and adjust rip fence.</li> </ol>
Blade is not aligned with miter slot or fence.	<ol style="list-style-type: none"> <li>1. Blade is warped.</li> <li>2. Table top is not parallel to blade.</li> <li>3. Fence is not parallel to blade.</li> </ol>	<ol style="list-style-type: none"> <li>1. Replace blade (<b>Page 29</b>).</li> <li>2. Make table parallel to blade (<b>Page 61</b>).</li> <li>3. Make fence parallel to blade (<b>Page 65</b>).</li> </ol>
Blade does not reach 90°.	<ol style="list-style-type: none"> <li>1. 90° stop nuts are out of adjustment.</li> <li>2. Sawdust or debris stuck in trunnion slides.</li> </ol>	<ol style="list-style-type: none"> <li>1. Adjust 90° stop nuts (<b>Page 59</b>).</li> <li>2. Clean sawdust or debris out of trunnion slides.</li> </ol>
Blade hits insert at 45°.	<ol style="list-style-type: none"> <li>1. 45° limiting block is out of adjustment.</li> <li>2. Sawdust or debris stuck in trunnion slides.</li> <li>3. Slot in insert is inadequate.</li> <li>4. Table out of alignment.</li> <li>5. Blade position is incorrect.</li> </ol>	<ol style="list-style-type: none"> <li>1. Adjust 45° limiting block (<b>Page 60</b>).</li> <li>2. Clean sawdust or debris out of trunnion slides.</li> <li>3. File or mill the slot in the insert.</li> <li>4. Align blade to the table (<b>Page 61</b>).</li> <li>5. Adjust blade position.</li> </ol>
Board binds or burns when feeding through table saw.	<ol style="list-style-type: none"> <li>1. Dull blade.</li> <li>2. Blade is warped.</li> <li>3. Fence is not parallel to blade.</li> <li>4. Table top is not parallel to blade.</li> </ol>	<ol style="list-style-type: none"> <li>1. Replace blade (<b>Page 29</b>).</li> <li>2. Replace blade (<b>Page 29</b>).</li> <li>3. Make fence parallel to blade (<b>Page 65</b>).</li> <li>4. Make table parallel to blade (<b>Page 61</b>).</li> </ol>
Handwheel binds or is difficult to move.	<ol style="list-style-type: none"> <li>1. Lock knob is engaged.</li> <li>2. Handwheel shaft pins are wedged.</li> </ol>	<ol style="list-style-type: none"> <li>1. Loosen lock knob.</li> <li>2. Remove handwheel and adjust shaft pins.</li> </ol>
Blade too close to insert.	<ol style="list-style-type: none"> <li>1. Blade position on arbor is incorrect.</li> </ol>	<ol style="list-style-type: none"> <li>1. Verify that blade arbor washers are correct and in the required position.</li> </ol>
Blade will not go beneath table surface.	<ol style="list-style-type: none"> <li>1. Roll pin/set screw in worm gear contacting geared trunnion.</li> </ol>	<ol style="list-style-type: none"> <li>1. Tighten roll pins and set screws in the worm gear.</li> </ol>
Blade will not move up or down.	<ol style="list-style-type: none"> <li>1. Set screw on worm gear is loose or missing.</li> </ol>	<ol style="list-style-type: none"> <li>1. Tighten or replace set screw.</li> </ol>
Too much sawdust blown back toward operator.	<ol style="list-style-type: none"> <li>1. Blade guard has been removed.</li> <li>2. Too many air leaks in cabinet for proper dust collection.</li> <li>3. Dust collection system clogged; too weak.</li> <li>4. Fence not parallel with blade (pressure at blade backside).</li> <li>5. Miter slot/fence not parallel with blade at 90°.</li> </ol>	<ol style="list-style-type: none"> <li>1. Re-install blade guard for maximum safety and dust control.</li> <li>2. Seal leaks in cabinet or around dust chute.</li> <li>3. Remove clog; revise ducting layout for improved suction; use a different dust collector.</li> <li>4. Adjust fence parallel with blade (<b>Page 65</b>).</li> <li>5. Adjust table so miter slot is parallel with blade at 90° (<b>Page 61</b>).</li> </ol>
Workpiece catches on table/dado insert or table throat during cutting operation.	<ol style="list-style-type: none"> <li>1. Table/dado insert out of adjustment.</li> </ol>	<ol style="list-style-type: none"> <li>1. Adjust table/dado insert so it is perfectly flush with table surface (<b>Page 66</b>).</li> </ol>



# Blade Tilt Calibration

The blade tilt settings for this saw have been set at the factory and should not require adjustment during assembly. However, after prolonged use, or if the saw does not cut accurate bevels, the settings should be checked and adjusted accordingly.

**Note:** The tilt scale reads "0" when the blade is 90° to the table.

Tools Needed	Qty
90° Square .....	1
45° Square .....	1
Hex Wrench 4mm.....	1

## Setting 90° Stop

1. DISCONNECT SAW FROM POWER!
2. Raise blade as high as it will go, then tilt it toward 90° until it stops and cannot be tilted any more.
3. Place a 90° square against table and blade so it contacts blade evenly from bottom to top, as shown in **Figure 112**. Make sure a blade tooth does not obstruct placement of square.

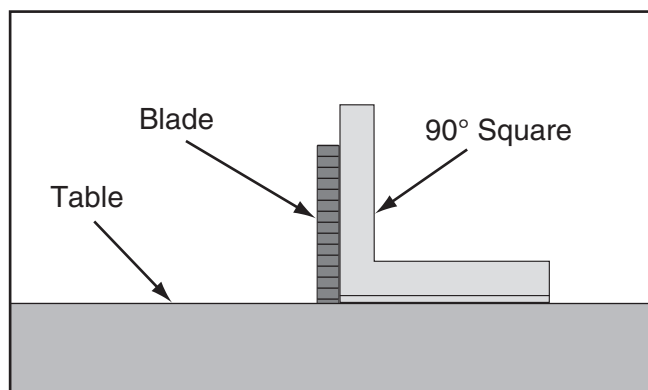

**Figure 112.** Checking blade at 90°.

—If blade is 90° to table, then no adjustments are necessary. Make sure tilt indicator arrow shown in **Figure 113** points to 0° mark on scale. Adjust position by loosening Phillips head screws, moving indicator with your fingers, then tightening screws.



**Figure 113.** Tilt indicator arrow.

—If blade is not 90° to table, you will need to adjust 90° stop nuts. Proceed to **Step 4**.

4. Remove motor cover (see **Page 19**).
5. Loosen (2) M8-1.25 hex nuts on leadscrew (see **Figure 114**).

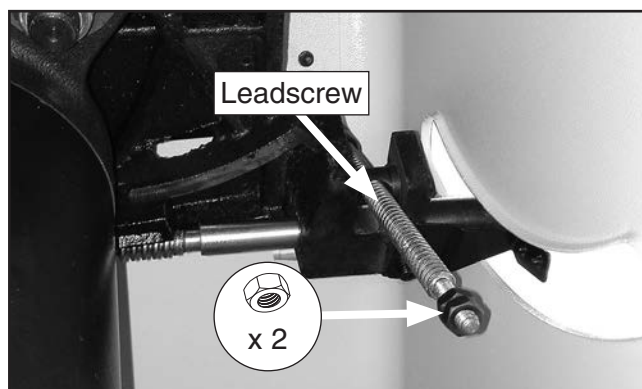

**Figure 114.** Location of 90° stop nuts.

6. Tilt blade to about 5° so there is room for stop nuts to move.
7. Loosen stop nuts and adjust according to how far off blade was from 90°. Recheck blade and repeat adjustment as necessary until blade stops at 90°, then tighten stop nuts against each other and replace motor cover.

**Note:** Turning stop nuts clockwise adjusts blade further to right; turning them counter-clockwise adjusts blade to left.



## Setting 45° Stop

1. DISCONNECT SAW FROM POWER!
2. Raise blade as high as it will go, then tilt it towards 45° until it stops and cannot be tilted any more.
3. Place a 45° square against table and blade so it contacts blade evenly from bottom to top, as shown in **Figure 115**. Make sure a blade tooth does not obstruct placement of square.

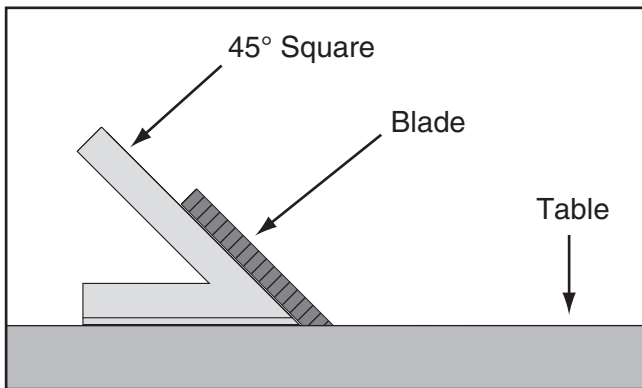

**Figure 115.** Checking blade at 45°.

—If blade *is* 45° to table, then no adjustments need to be made. Proceed to **Step 8**.

—If blade *is not* 45° to table, you will need to adjust 45° limiting block. Proceed to **Step 4**.

4. Remove rear access panel.

5. Loosen (2) M5-.8 x 10 cap screws in 45° limiting block (see **Figure 116**).

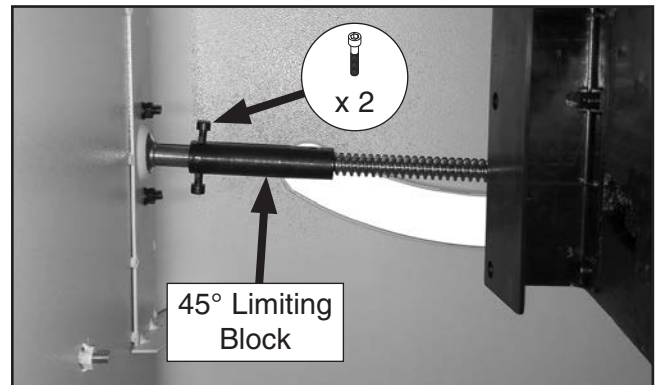

**Figure 116.** Location of 45° limiting block.

6. Tilt blade away from 45° by about 5°, so there is room for limiting block to move.
7. Adjust 45° limiting block according to how far off blade was from 45°, then recheck blade and repeat adjustment as necessary until blade stops at 45°, then tighten cap screws and replace rear access panel.
8. Make sure tilt indicator arrow points to 45° mark on scale. If it doesn't, adjust indicator arrow as described on **Page 59**.



# Miter Slot to Blade Parallelism

Your table saw will give the best results if the miter slot and the rip fence are adjusted parallel to the blade. If either of these are not exactly parallel, your cuts and your finished work will be lower in quality, but more importantly, the risk of kickback will be increased.

Tools Needed	Qty
Adjustable Square .....	1
Marker .....	1
Metal Shim Stock .....	As Needed
Open-End Wrench 12mm.....	1

## To adjust blade parallel to miter slot:

1. DISCONNECT SAW FROM POWER!
2. Tilt blade to 0°, then use an adjustable square to measure distance from miter slot to a carbide tip on blade, as shown in **Figure 117**. Make sure that face of adjustable square is even along miter slot.

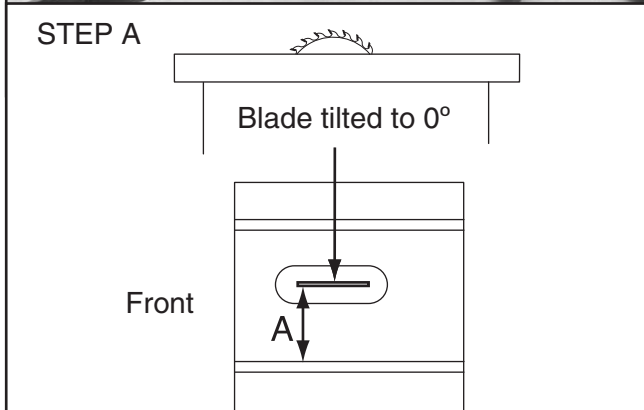
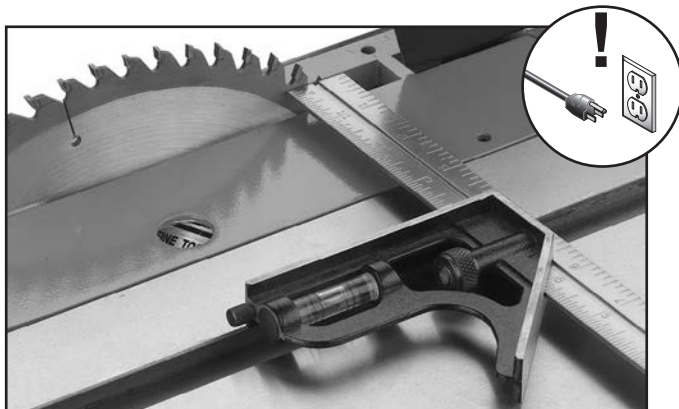

**Figure 117.** Example of adjusting blade to miter slot.

3. With end of adjustable square just touching tip, lock square in place. Now, mark carbide tip with a marker where you made this measurement.

**⚠ CAUTION**

**The saw blade is sharp. Use extra care or wear gloves when handling the blade or working near it.**

4. Rotate marked blade tip to other end of table insert.
5. Slide adjustable square down to other end of table insert and compare distance from marked blade tip to end of adjustable square, as shown in **Figure 118**.

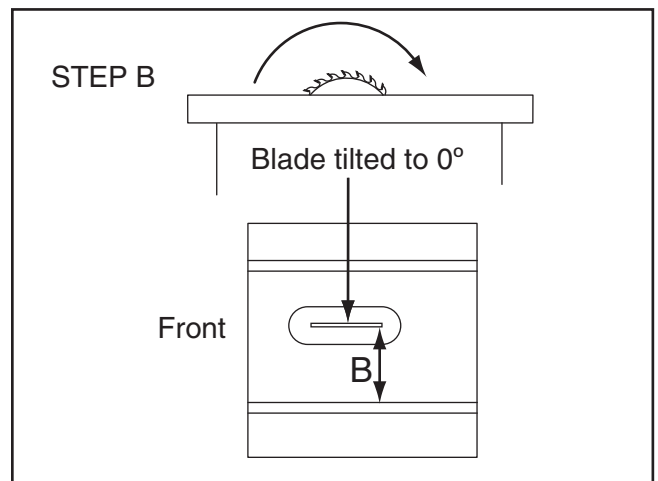
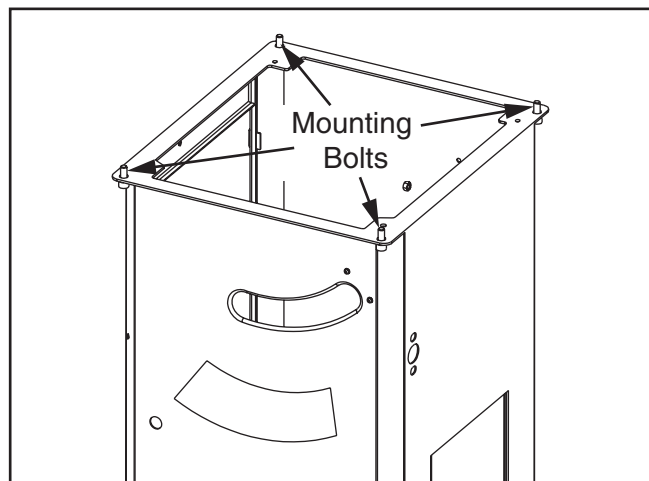

**Figure 118.** Measuring distance from miter slot to carbide tip on opposite side of table insert.

- If blade tip measurement is same on both sides, go to **Step 8**.
- If blade tip does not touch end of adjustable square similar to first measurement, table will need to be adjusted. Proceed to **Step 6**.



- Loosen (4) table mounting bolts securing table top to base (see **Figure 119**), and lightly tap table in direction needed to square table to blade.



**Figure 119.** Location of table mounting bolts (table omitted for clarity).

- Repeat **Steps 2–6** until blade and miter slot are parallel, then tighten retighten table mounting bolts.
- Tilt blade to  $45^\circ$  and recheck miter slot-to-blade parallelism.
  - If blade is still parallel with miter slot, no additional adjustments need to be made.
  - If blade was parallel with miter slot at  $0^\circ$  but not at  $45^\circ$ , one end of table will need to be shimmed higher with metal shim stock. Continue to **Step 9**.
- Loosen (4) table mounting bolts from **Step 6**.

- Refer to **Figures 120–121** for shim placement. If distance A is shorter than B, shim(s) will need to be placed under corners #1 and #2. If the distance of B is shorter than A, shim(s) will need to be placed under corner #3. Very thin shim stock works well.

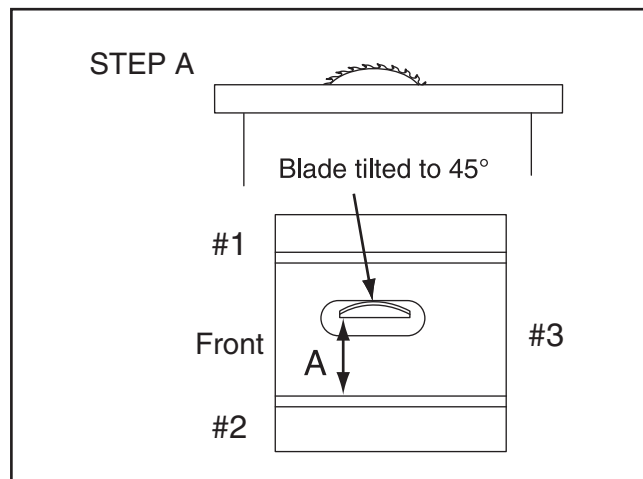

**Figure 120.** Shim procedure diagram A.

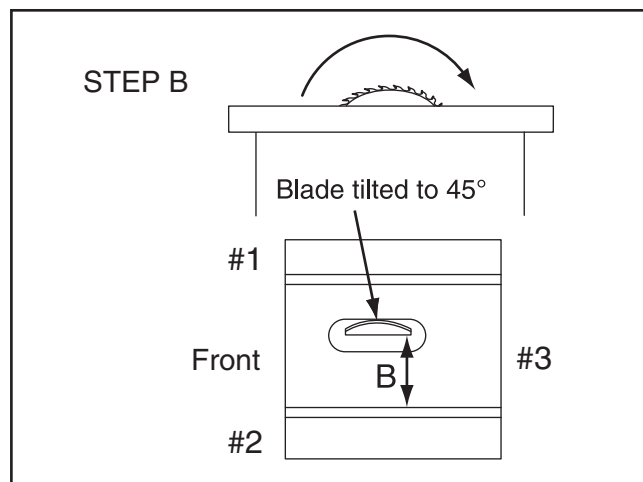

**Figure 121.** Shim procedure diagram B.





11. Tighten one table mounting bolt a small amount and then repeat with the others, tightening each down the same amount. Continue this process with all the bolts, tightening them a little each time until they are all secure.

12. Now recheck blade to miter slot at 0° and 45° by repeating **Steps 2-5**.

—If distance of A and B are equal, continue to **Step 13**.

—If distances are still off, repeat **Steps 9–12**.

13. Once miter slot is adjusted to blade, recheck all measurements and be sure table mounting bolts are secure.

**Note:** *If you remove the table in the future, note the shim placements and reassemble them exactly how they came apart.*

# Spreader or Riving Knife Alignment

## Checking Alignment

The blade guard spreader/riving knife must be aligned with the blade when installed. If the spreader/riving knife is not aligned with the blade, then the workpiece will be forced sideways during the cut, which will increase the risk of kickback.

Tools Needed	Qty
Straightedge (min. 12")	1

### To check spreader/riving knife alignment:

1. DISCONNECT SAW FROM POWER!
2. Raise saw blade to maximum height so you have easy working access.
3. Place straightedge against top and bottom of blade and spreader/riving knife, as shown in **Figure 122**. Spreader/riving knife should be parallel with blade at both positions and in the "Alignment Zone," as shown in **Figure 123**.

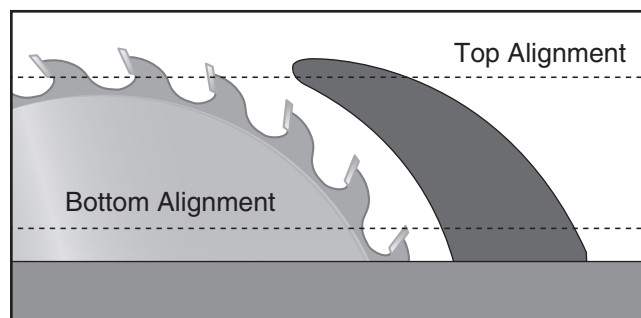

**Figure 122.** Example of checking top and bottom riving knife parallelism with blade.

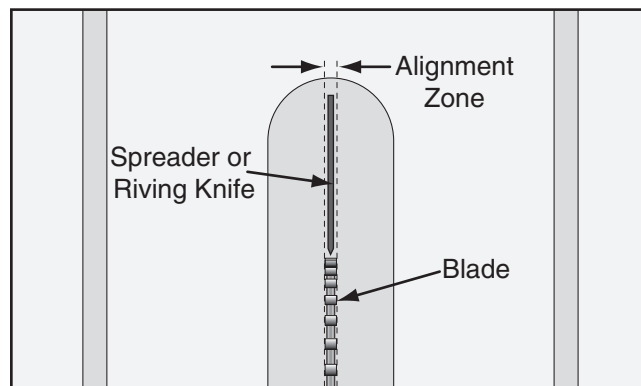

**Figure 123.** Spreader/riving knife alignment zone.



- If spreader *is* in alignment zone no adjustments need to be made.
- If spreader/riving knife *is not* parallel with blade and inside alignment zone, then it needs to be adjusted. Proceed to **Adjusting Alignment** instructions.
- If spreader/riving knife *is not* parallel with blade at either top or bottom, it may be bent. Remove spreader/riving knife, place it on a flat surface and check to see if spreader/riving knife lies evenly along its length.
- If spreader/riving knife does not lie evenly, proceed to **Adjusting Bent Spreader/Riving Knife** procedure.

## Adjusting Alignment

The spreader/riving knife mounting position can be adjusted into alignment with the blade using the cap screws on the spreader/riving knife "L" bracket.

Possible Tools Needed	Qty
Hex Wrench 4mm.....	1

### To adjust spreader/riving knife position:

1. DISCONNECT SAW FROM POWER!
2. Remove table insert, but leave Phillips head screws mounted in table throat.

**Note:** Table insert is held in place by a magnet.

3. Loosen two cap screws on the "L" bracket (see **Figure 124**), then slide spreader/riving knife as needed to move it into alignment with blade.

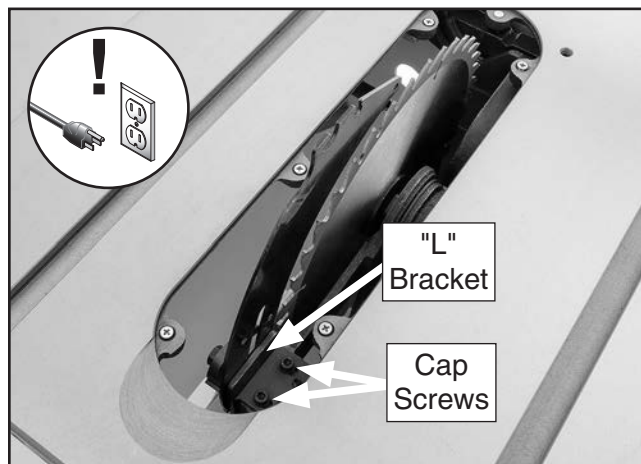

**Figure 124.** Cap screws for adjusting spreader/riving knife position.

4. Follow **Checking Alignment, Steps 1–3**.
  - If spreader/riving knife *is* in alignment zone, no additional steps are necessary.
  - If spreader/riving knife is still *not* in alignment zone, continue adjusting position of "L" bracket as necessary to correctly align spreader/riving knife.
5. Tighten two cap screws on mounting block to secure spreader/riving knife adjustment.
6. Replace table insert (refer to **Page 66**).

## Adjusting Bent Spreader/Riving Knife

1. DISCONNECT SAW FROM POWER!
2. Bend spreader/riving knife by hand while installed, then follow **Steps 1–3** in **Checking Alignment** to determine if it is parallel with blade and inside "Alignment Zone" (refer to **Checking Alignment**).
  - If this does not work, remove spreader/riving knife to straighten.
  - If you cannot straighten spreader/riving knife properly, replace it.



# Calibrating Fence to Blade

Four cap screws on the top front of the fence position it relative to the blade (see **Figure 125**). Follow the procedures below to check the fence parallelism and adjust it if necessary.

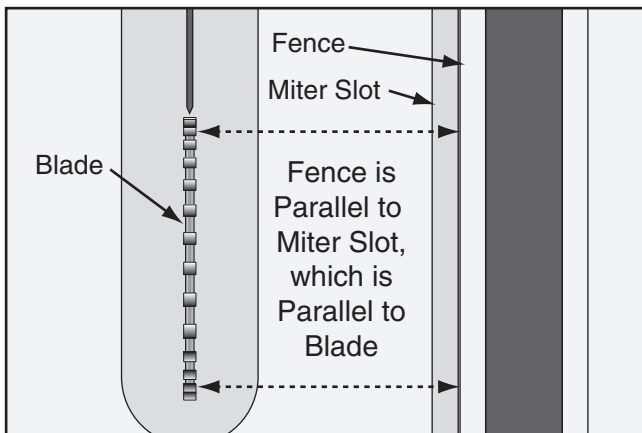

**Figure 125.** Location of adjustment screws for setting fence parallelism.

Tools Needed	Qty
Hex Wrench 5mm.....	1
Framing Square.....	1

## To check fence parallelism:

1. DISCONNECT SAW FROM POWER!
2. Slide fence up against right edge of miter slot, lock it in place, then raise blade above insert. Using a ruler, examine how fence lines up with miter slot and blade (see **Figure 126**).



**Figure 126.** Checking fence parallelism with blade.

## Adjusting fence parallel to blade:

1. DISCONNECT SAW FROM POWER!
2. Unlock fence, align left side of fence with right edge of miter slot, then lock fence.
3. Check to make sure fence is parallel with blade (see **Figure 126**).
  - If fence *is* parallel with blade, no further adjustments need to be made.
  - If fence *is not* parallel with blade, proceed to **Step 4**.
4. Loosen four adjustment screws on top front of fence, as indicated in **Figure 125**.
5. Position fence so it is parallel with blade.
6. Tighten four adjustment screws.

## Offsetting Fence

Some woodworkers prefer to offset the rear of the fence  $\frac{1}{64}$ " from the blade, as shown in **Figure 127**.

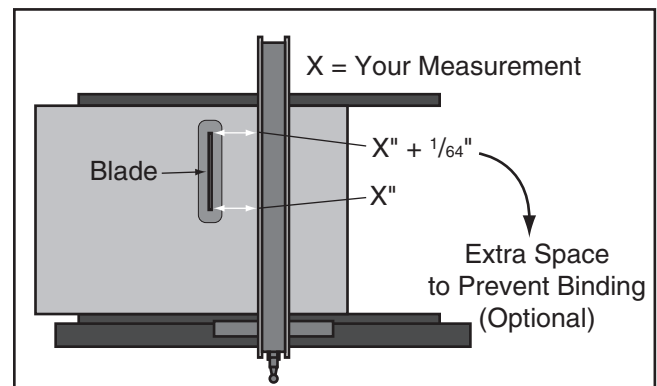

**Figure 127.** Example of adjusting fence with a  $\frac{1}{64}$ " offset.

The reason for this wider gap at the back side of the blade is to help prevent the chance of kickback and the blade burning the workpiece because a workpiece may be inconsistent. However, the trade-off is less accurate cuts, and if the fence is placed on the other side of blade for other table saw operations, the potential of workpiece burning and kickback can be increased. Whenever using a fence, make sure that if an offset has been adjusted in the fence alignment, you use the fence on the side of the blade where the offset creates the wide gap.



# Fence Scale Calibration

The fence scale windows, shown in **Figure 128**, can be calibrated with the fence scale by loosening the mounting screws and sliding them in the desired direction. The indicator window on the right side is used when the fence is positioned to the right side of the blade. The indicator window on the left is used when the fence is positioned on the left side of the blade.

**IMPORTANT:** Do not use the fence on the left side of the blade if it has been purposely offset, and is not adjusted parallel with blade.

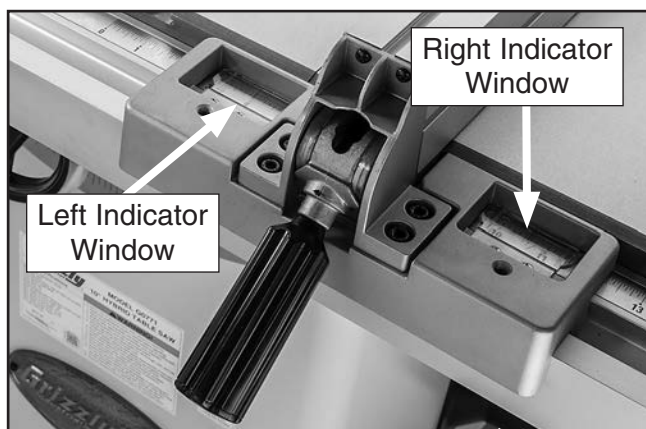

**Figure 128.** Fence indicator windows.

Tools Needed	Qty
Phillips Head Screwdriver #2 .....	1
Scrap Piece of Wood.....	1

### To calibrate fence scale indicator windows:

1. Lock fence at 13" and cut your scrap piece of wood.
2. Reposition and lock fence at 12", as indicated by the scale.
3. Flip over your scrap piece of wood, placing side that was cut in **Step 1** against fence, then make your cut.
4. Measure width of freshly cut workpiece at both ends with a tape measure. Workpiece width should be exactly 12" at front and back. If it is not, then adjust indicator window to match width of workpiece.

# Table/Dado Insert Adjustment

The table/dado insert must sit perfectly flush with the table to provide a smooth, continuous surface for the workpiece to slide over. The insert is held in place by a magnet and sits on top of five adjustment screws (see **Figure 129**). The insert should be checked and adjusted any time it is removed and replaced, after prolonged use, or any time you notice the workpiece does not slide smoothly across the insert.

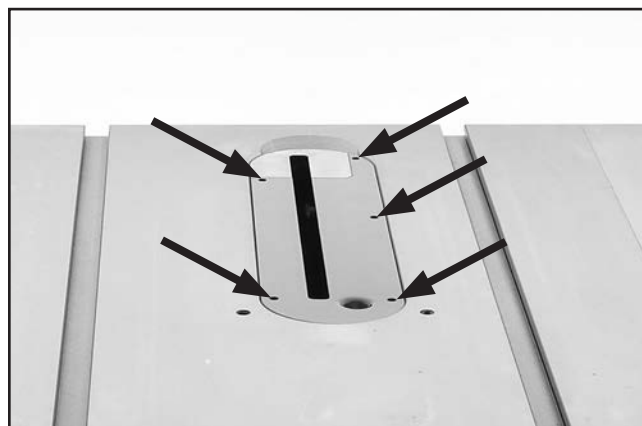

**Figure 129.** Location of table/dado insert holes with adjustment screws.

Tools Needed	Qty
Phillips Head Screwdriver #2 .....	1
Straight Edge.....	1

### To check and adjust insert:

1. DISCONNECT MACHINE FROM POWER!
2. Place straight edge across insert and check to make sure insert is flush with table at front and back of throat.
  - If insert is flush with table, no adjustments are necessary.
  - If insert is not flush with table, proceed to **Step 3**.
3. Insert screwdriver through holes shown in **Figure 129** and either loosen screws to raise insert, or tighten screws to lower it. Repeat **Steps 2–3** until insert is perfectly flush with surface of table.



# Miter Gauge Adjustments

The miter gauge is equipped with stop screws that allow you to easily adjust the miter gauge 0°–30° left, 90°, and 0°–45° right. The stop screws contact the shaft, which moves in or out of the way for adjustments.

Tools Needed	Qty
Phillips Head Screwdriver.....	1
90° Square .....	1
45° Square .....	1
30° Square .....	1
Wrench 8mm .....	1

## Checking/Setting 90° Stops

1. DISCONNECT SAW FROM POWER!
2. Slide miter gauge into T-slot on table.
3. Place square evenly against face of miter gauge and blade, as shown in **Figure 130**.

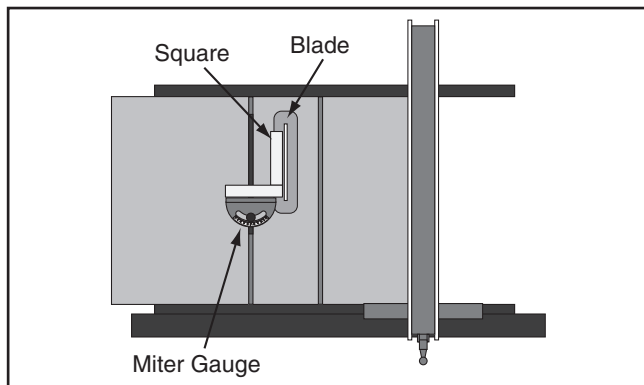

**Figure 130.** Checking 90° stop on miter gauge.

—If square touches miter body and body of blade evenly at same time, then it is square to blade. No adjustments are necessary.

—If square does *not* touch miter body and blade evenly, then proceed to **Step 5**.

4. Remove miter gauge from miter slot.

5. Loosen two Phillips head screws that secure 90° stop plate (see **Figure 131**).

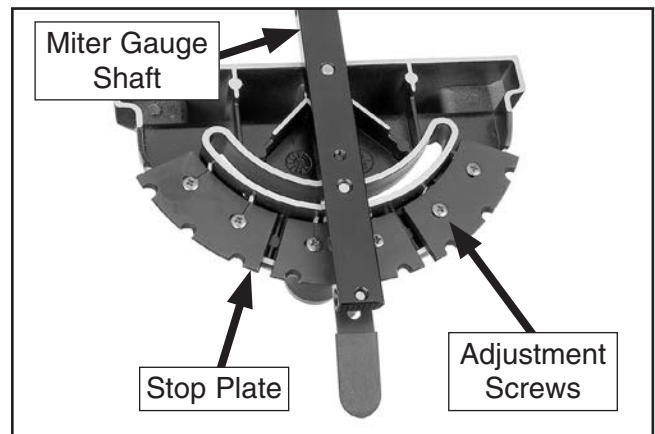

**Figure 131.** Checking 45° stop on miter gauge.

6. Using a square, position miter shaft at 90° to miter gauge body.
7. Tighten stop plate screws.

## Checking/Setting 45° Stops

Follow the same process with the 45° and 30° stops that you followed with the 90°, except using a 45° square or adjustable square to verify that the miter body is 45° to the blade.



# Belt Tension & Replacement

The drive belt stretches slightly as the saw is used. Most of the belt stretching will happen during the first 16 hours of use, but it may continue with further use. If you notice that the saw is losing power in the middle of a cut, the belt may be slipping, and will need to be tensioned. If, upon inspection, you find that the belt is cracked, frayed, or shows other signs of excessive wear, replace it.

Tools Needed	Qty
Open-End or Socket Wrench 13mm .....	1

## Tensioning Belt

1. DISCONNECT SAW FROM POWER!
2. Remove motor cover from side of machine.
3. Set blade to 0° on tilt scale, then raise or lower blade to approximately 2" above table.
4. Loosen blade tension hex bolt shown in **Figure 132**.

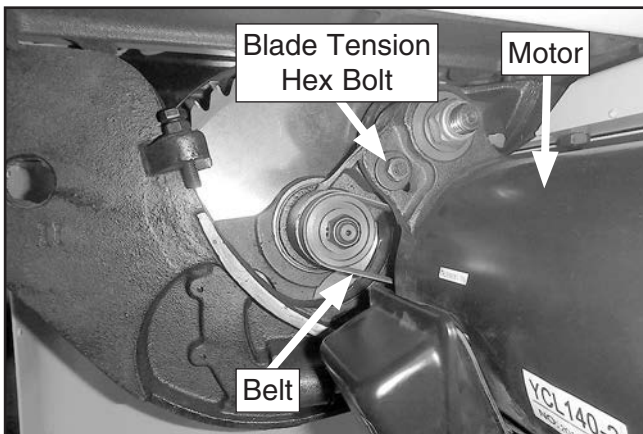

**Figure 132.** Components used to tension or remove belt.

5. Use blade height handwheel to lower motor. When motor starts to pull blade down with it, belt is tensioned.
6. Retighten blade tension hex bolt, then re-install motor cover.

## Replacing Belt

1. DISCONNECT SAW FROM POWER!
2. Remove motor cover from side of machine.
3. Set blade to 0° on tilt scale, then raise or lower blade to approximately 2" above table.
4. Loosen blade tension hex bolt, shown in **Figure 132**.
5. Use blade height handwheel to raise motor and loosen belt, then remove belt.
6. Install new belt onto pulleys. Lower motor until it begins to pull blade down with it, then retighten blade tension hex bolt.
7. Re-install motor cover.



# SECTION 9: WIRING

These pages are current at the time of printing. However, in the spirit of improvement, we may make changes to the electrical systems of future machines. Compare the manufacture date of your machine to the one stated in this manual, and study this section carefully.

If there are differences between your machine and what is shown in this section, call Technical Support at (570) 546-9663 for assistance BEFORE making any changes to the wiring on your machine. An updated wiring diagram may be available. **Note:** *Please gather the serial number and manufacture date of your machine before calling. This information can be found on the main machine label.*

## WARNING

### Wiring Safety Instructions

**SHOCK HAZARD.** Working on wiring that is connected to a power source is extremely dangerous. Touching electrified parts will result in personal injury including but not limited to severe burns, electrocution, or death. Disconnect the power from the machine before servicing electrical components!

**MODIFICATIONS.** Modifying the wiring beyond what is shown in the diagram may lead to unpredictable results, including serious injury or fire. This includes the installation of unapproved after-market parts.

**WIRE CONNECTIONS.** All connections must be tight to prevent wires from loosening during machine operation. Double-check all wires disconnected or connected during any wiring task to ensure tight connections.

**CIRCUIT REQUIREMENTS.** You MUST follow the requirements at the beginning of this manual when connecting your machine to a power source.

**WIRE/COMPONENT DAMAGE.** Damaged wires or components increase the risk of serious personal injury, fire, or machine damage. If you notice that any wires or components are damaged while performing a wiring task, replace those wires or components.

**MOTOR WIRING.** The motor wiring shown in these diagrams is current at the time of printing but may not match your machine. If you find this to be the case, use the wiring diagram inside the motor junction box.















**CAPACITORS/INVERTERS.** Some capacitors and power inverters store an electrical charge for up to 10 minutes after being disconnected from the power source. To reduce the risk of being shocked, wait at least this long before working on capacitors.

**EXPERIENCING DIFFICULTIES.** If you are experiencing difficulties understanding the information included in this section, contact our Technical Support at (570) 546-9663.

#### NOTICE

The photos and diagrams included in this section are best viewed in color. You can view these pages in color at [www.grizzly.com](http://www.grizzly.com).

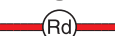
#### COLOR KEY

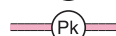
BLACK 	BLUE 	YELLOW 	LIGHT BLUE 
WHITE 	BROWN 	YELLOW GREEN 	BLUE WHITE 
GREEN 	GRAY 	PURPLE 	TURQUOISE 
RED 	ORANGE 	PINK 	



# Wiring Diagram

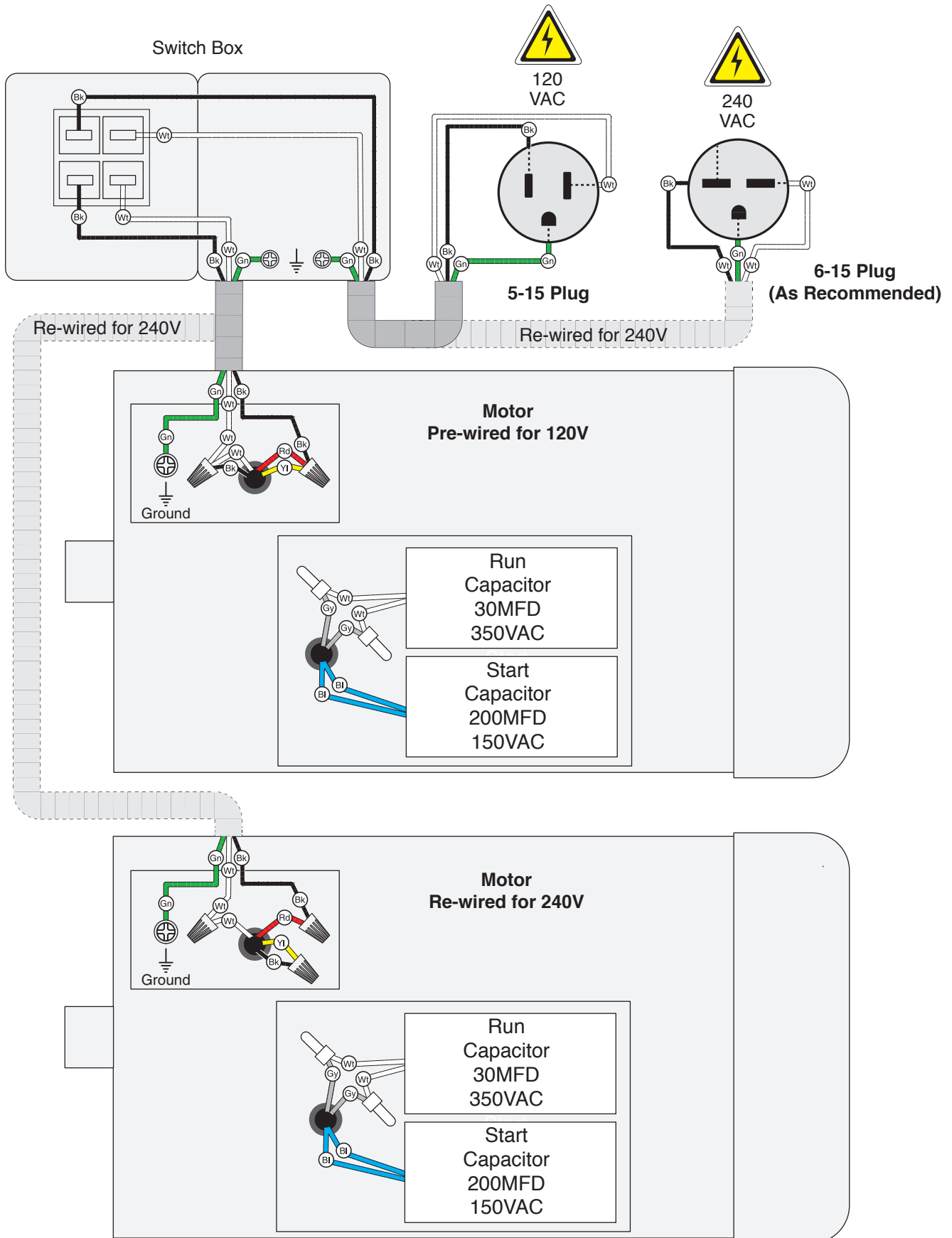



# Electrical Components

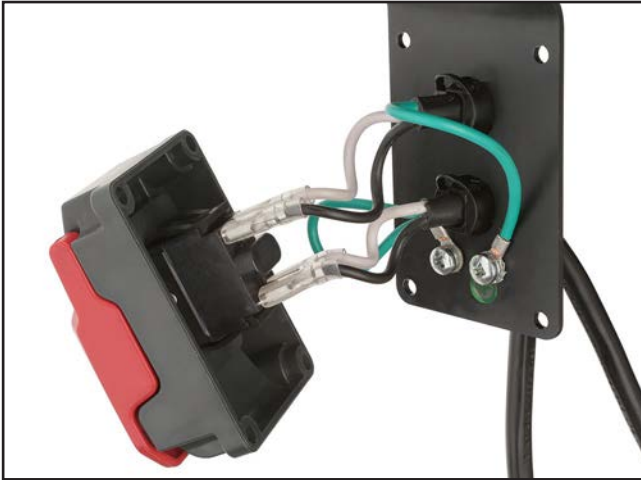

Figure 133. Switch wiring.



Figure 136. Motor wiring at 120V.



Figure 134. Capacitors.

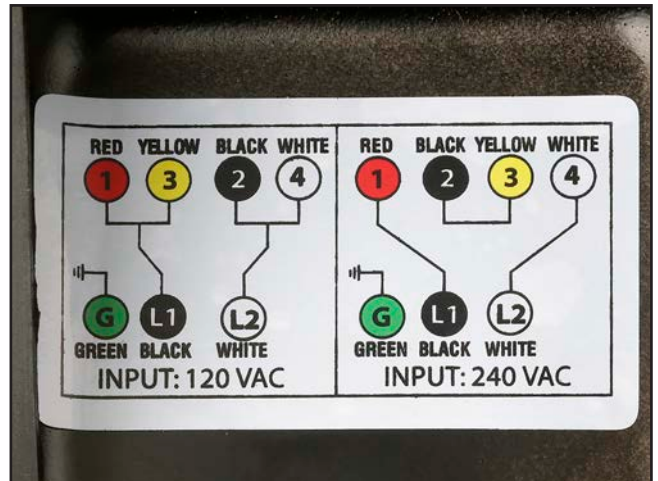

Figure 137. Motor wiring label inside junction box.

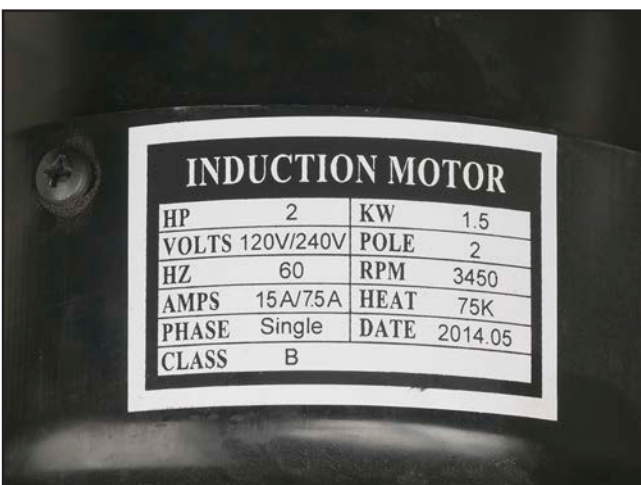
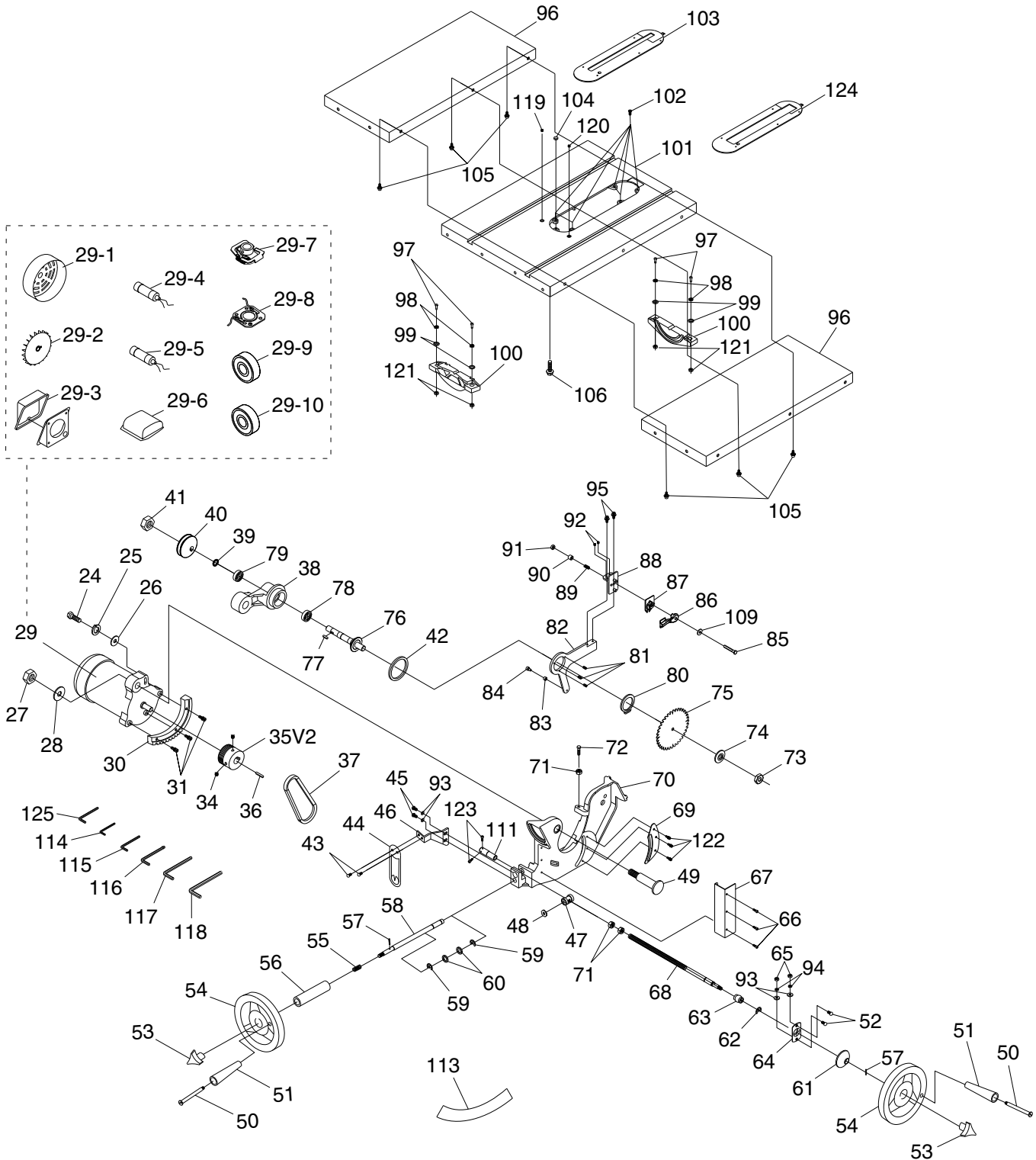

Figure 135. Motor label.

# SECTION 10: PARTS

## Main



**Please Note:** We do our best to stock replacement parts whenever possible, but we cannot guarantee that all parts shown here are available for purchase. Call (800) 523-4777 or visit our online parts store at [www.grizzly.com](http://www.grizzly.com) to check for availability.



# G0771 Main Parts List

REF	PART #	DESCRIPTION
24	P0771024	HEX BOLT M8-1.25 X 30
25	P0771025	LOCK WASHER 8MM
26	P0771026	FLAT WASHER 8MM
27	P0771027	LOCK NUT M16-2
28	P0771028	FLAT WASHER 16MM
29	P0771029	MOTOR 2HP 110V/220V 1-PH
29-1	P0771029-1	MOTOR FAN COVER
29-2	P0771029-2	MOTOR FAN
29-3	P0771029-3	MOTOR JUNCTION BOX
29-4	P0771029-4	R CAPACITOR 30M 350V 1-5/8 X 3-1/8
29-5	P0771029-5	S CAPACITOR 200M 150V 1-3/8 X 2-11/16
29-6	P0771029-6	CAPACITOR COVER
29-7	P0771029-7	CENTRIFUGAL SWITCH
29-8	P0771029-8	CONTACT PLATE
29-9	P0771029-9	BALL BEARING 6203Z
29-10	P0771029-10	BALL BEARING 6202Z
30	P0771030	BULL GEAR
31	P0771031	CAP SCREW W/WASHER M6-1 X 25
34	P0771034	SET SCREW M5-.8 X 8
35V2	P0771035V2	MOTOR PULLEY J6 X 5/8" BORE V2.06.15
36	P0771036	KEY 5 X 5 X 30
37	P0771037	POLY-V BELT 355J6
38	P0771038	BLADE BRACKET
39	P0771039	ARBOR BUSHING
40	P0771040	ARBOR PULLEY
41	P0771041	LOCK NUT M12-1.5
42	P0771042	SHIM WASHER
43	P0771043	PHLP HD SCR M4-.7 X 6
44	P0771044	BEVEL INDICATOR
45	P0771045	CAP SCREW M5-.8 X 8
46	P0771046	POINTER SEAT
47	P0771047	BEVEL NUT
48	P0771048	SHIM WASHER
49	P0771049	MAIN TRUNNION SHAFT
50	P0771050	HANDLE BOLT
51	P0771051	HANDWHEEL HANDLE 106MM SS
52	P0771052	CAP SCREW M5-.8 X 16
53	P0771053	LOCK HANDLE
54	P0771054	HANDWHEEL 180MM X 11MM ALUMINUM
55	P0771055	COMPRESSION SPRING
56	P0771056	ELEVATION BUSHING
57	P0771057	ROLL PIN 3 X 20
58	P0771058	ELEVATION SHAFT
59	P0771059	E-CLIP 14MM
60	P0771060	SPACER
61	P0771061	BEVEL PLATE
62	P0771062	E-CLIP 9MM
63	P0771063	BALL BEARING 6201ZZ
64	P0771064	BEARING SEAT
65	P0771065	HEX NUT M5-.8
66	P0771066	CAP SCREW M5-.8 X 10
67	P0771067	BLADE GUARD
68	P0771068	TILT SHAFT

REF	PART #	DESCRIPTION
69	P0771069	RIVING GUIDE
70	P0771070	MAIN TRUNNION
71	P0771071	HEX NUT M8-1.25
72	P0771072	HEX BOLT M8-1.25 X 40
73	P0771073	HEX NUT 5/8-18
74	P0771074	BLADE FLANGE
75	P0771075	BLADE 10" X 5/8" X 40T
76	P0771076	ARBOR
77	P0771077	KEY 5 X 5 X 12
78	P0771078	BALL BEARING 6203ZZ
79	P0771079	BALL BEARING 6202ZZ
80	P0771080	EXT RETAINING RING 52MM
81	P0771081	CAP SCREW M5-.8 X 6
82	P0771082	MOUNTING PLATE
83	P0771083	BUSHING
84	P0771084	SHAFT PIN
85	P0771085	RIVING CLAMP LOCK BOLT M8-1.25 X 53
86	P0771086	RIVING LOCK LEVER
87	P0771087	RIVING CLAMP
88	P0771088	RIVING DECK
89	P0771089	COMPRESSION SPRING
90	P0771090	RIVING SEAT
91	P0771091	LOCK NUT M8-1.25
92	P0771092	SET SCREW M5-.8 X 10
93	P0771093	FLAT WASHER 5MM
94	P0771094	LOCK WASHER 5MM
95	P0771095	CAP SCREW W/WASHER M5-.8 X 16
96	P0771096	EXTENSION TABLE
97	P0771097	CAP SCREW M10-1.5 X 40
98	P0771098	LOCK WASHER 10MM
99	P0771099	FLAT WASHER 10MM
100	P0771100	TRUNNION
101	P0771101	MAIN TABLE
102	P0771102	FLAT HD SCR 8-32 X 1/2
103	P0771103	TABLE INSERT
104	P0771104	TABLE INSERT MAGNET
105	P0771105	CAP SCREW M10-1.5 X 30
106	P0771106	FLANGE BOLT M8-1.25 X 16
109	P0771109	FLAT WASHER 8MM
111	P0771111	90° LIMITING BLOCK
113	P0771113	BEVEL LABEL
114	P0771114	HEX WRENCH 3MM
115	P0771115	HEX WRENCH 4MM
116	P0771116	HEX WRENCH 5MM
117	P0771117	HEX WRENCH 6MM
118	P0771118	HEX WRENCH 8MM
119	P0771119	SET SCR M8-1.25 X 20 CUP-PT NYLOCK
120	P0771120	SET SCR M8-1.25 X 25 CUP-PT NYLOCK
121	P0771121	HEX NUT M10-1.5
122	P0771122	CAP SCREW W/WASHER M5-.8 X 10
123	P0771123	CAP SCREW M5-.8 X 10
124	P0771124	DADO TABLE INSERT
125	P0771125	HEX WRENCH 2.5MM



# Cabinet

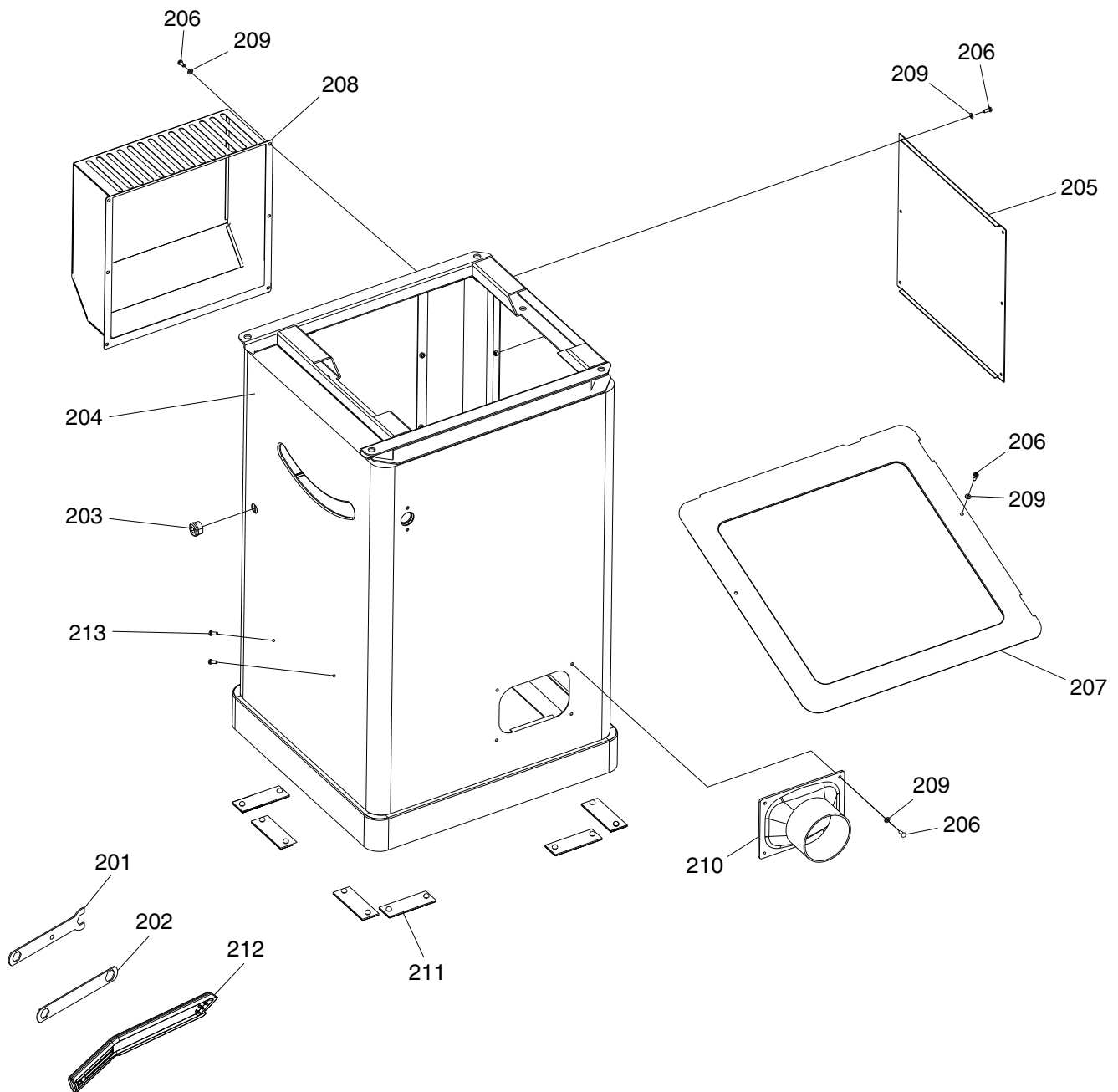

## REF PART # DESCRIPTION

201	P0771201	ARBOR WRENCH 16 X 23MM OPEN-END
202	P0771202	ARBOR WRENCH 13 X 22MM CLOSED-ENDS
203	P0771203	STRAIN RELIEF 1/2"-3/8" SNAP-IN ST
204	P0771204	CABINET
205	P0771205	REAR PANEL
206	P0771206	CAP SCREW M5-.8 X 12
207	P0771207	DUST COLLECTION GUIDE PLATE

## REF PART # DESCRIPTION

208	P0771208	MOTOR COVER
209	P0771209	FLAT WASHER 5MM
210	P0771210	DUST PORT
211	P0771211	RUBBER CUSHION
212	P0771212	PUSH STICK
213	P0771213	PHLP HD SCR M3-.5 X 16



# Fence & Rails

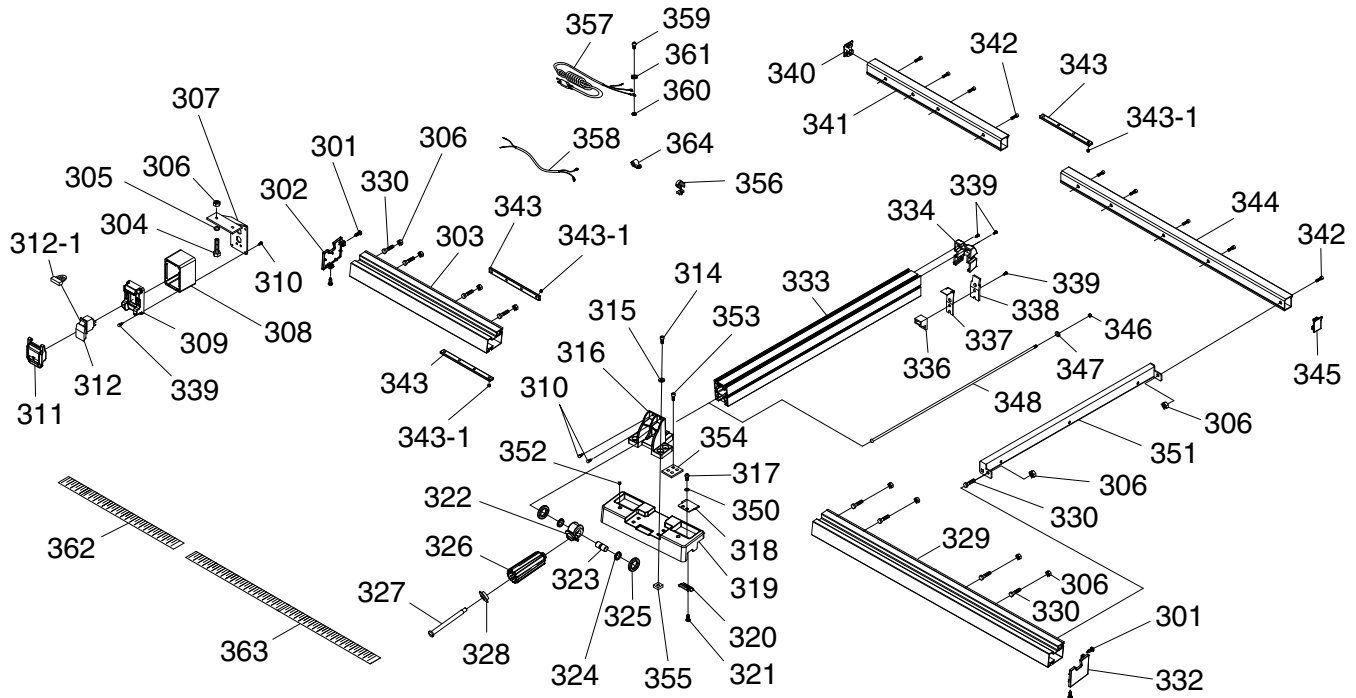

REF	PART #	DESCRIPTION
301	P0771301	TAP SCREW M4 X 10
302	P0771302	LEFT FRONT RAIL CAP
303	P0771303	LEFT FRONT RAIL
304	P0771304	HEX BOLT M8-1.25 X 16
305	P0771305	LOCK WASHER 8MM
306	P0771306	HEX NUT M8-1.25
307	P0771307	SWITCH BRACKET
308	P0771308	SWITCH BOX
309	P0771309	SWITCH PANEL
310	P0771310	TAP SCREW M4 X 14
311	P0771311	SWITCH PADDLE
312	P0771312	SWITCH KEDU HY18-20
312-1	P0771312-1	SWITCH KEY
314	P0771314	CAP SCREW M6-1 X 12
315	P0771315	FLAT WASHER 6MM
316	P0771316	UPPER FENCE CASTING
317	P0771317	PHLP HD SCR M4-.7 X 8
318	P0771318	INDICATOR
319	P0771319	LOWER FENCE CASTING
320	P0771320	SLIDER
321	P0771321	PHLP HD SCR M4-.7 X 10
322	P0771322	FENCE HANDLE SEAT
323	P0771323	FENCE LOCKING CAM SHAFT
324	P0771324	INNER PAD
325	P0771325	OUTER PAD
326	P0771326	FENCE HANDLE
327	P0771327	FENCE HANDLE BOLT
328	P0771328	FENCE HANDLE END CAP
329	P0771329	RIGHT FRONT RAIL
330	P0771330	HEX BOLT M8-1.25 X 30
332	P0771332	RIGHT FRONT RAIL CAP

REF	PART #	DESCRIPTION
333	P0771333	FENCE
334	P0771334	FENCE END CAP
336	P0771336	INNER LOCK PLATE
337	P0771337	SPRING PLATE
338	P0771338	OUTER LOCK PLATE
339	P0771339	TAP SCREW M4 X 20
340	P0771340	LEFT REAR RAIL CAP
341	P0771341	LEFT REAR RAIL
342	P0771342	CAP SCREW M8-1.25 X 20
343	P0771343	CONNECTING BAR
343-1	P0771343-1	SET SCREW M6-1 X 8
344	P0771344	RIGHT REAR RAIL
345	P0771345	RIGHT REAR RAIL CAP
346	P0771346	LOCK NUT M8-1.25
347	P0771347	FLAT WASHER 8MM
348	P0771348	LINKAGE SHAFT
350	P0771350	FLAT WASHER 4MM
351	P0771351	RAIL BRACE
352	P0771352	SET SCREW M8-1.25 X 20 PLASTIC
353	P0771353	CAP SCREW M6-1 X 12
354	P0771354	FENCE LOCK PLATE
355	P0771355	SQUARE NUT M6-1
356	P0771356	STRAIN RELIEF 1/2"-3/8" SNAP-IN ST
357	P0771357	POWER CORD 14G 3W 72" 5-15P
358	P0771358	MOTOR CORD 14G 3W 39"
359	P0771359	PHLP HD SCR M5-.8 X 8
360	P0771360	LOCK WASHER 5MM
361	P0771361	INT TOOTH WASHER 5MM
362	P0771362	LEFT FENCE SCALE
363	P0771363	RIGHT FENCE SCALE
364	P0771364	ADJUSTABLE CABLE CLAMP



# Blade Guard

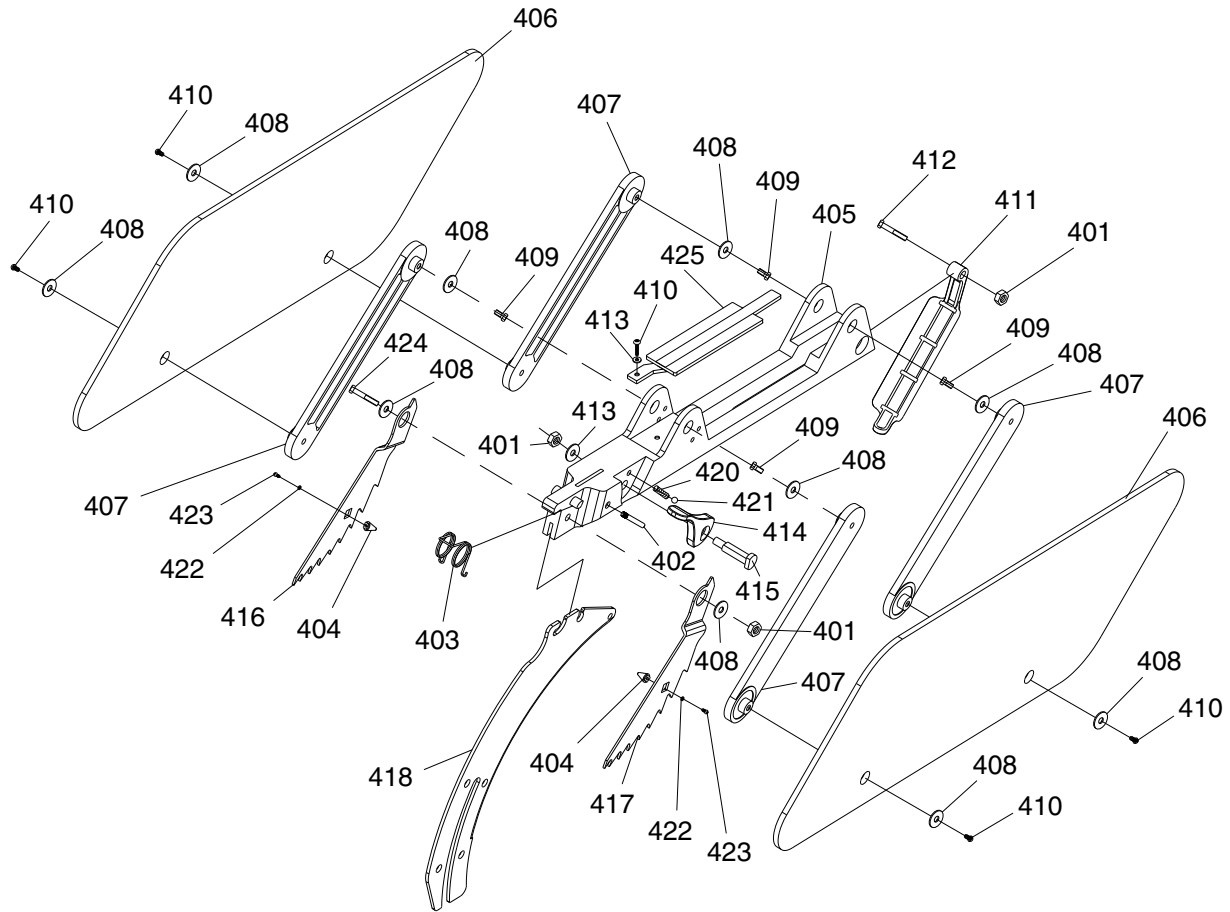

REF	PART #	DESCRIPTION
401	P0771401	LOCK NUT M5-.8
402	P0771402	SET PIN
403	P0771403	TORSION SPRING
404	P0771404	SCREW CAP
405	P0771405	BLADE GUARD BODY
406	P0771406	BARRIER
407	P0771407	BARRIER CONNECTING BAR
408	P0771408	FLAT WASHER 5MM
409	P0771409	HEX BOLT M5-.8 X 10
410	P0771410	PHLP HD SCR M5-.8 X 10
411	P0771411	GUARD RAIL
412	P0771412	PHLP HD SCR M5-.8 X 25

REF	PART #	DESCRIPTION
413	P0771413	FLAT WASHER 5MM
414	P0771414	BLADE GUARD LOCK LEVER
415	P0771415	BLADE GUARD LOCK LEVER SCREW
416	P0771416	ANTI-KICKBACK PAWL (L)
417	P0771417	ANTI-KICKBACK PAWL (R)
418	P0771418	SPREADER/RIVING KNIFE
420	P0771420	COMPRESSION SPRING
421	P0771421	STEEL BALL 4MM
422	P0771422	FLAT WASHER 3MM
423	P0771423	TAP SCREW M3 X 6
424	P0771424	CAP SCREW M5-.8 X 30
425	P0771425	BLADE GUARD WINDOW COVER



# Miter Gauge

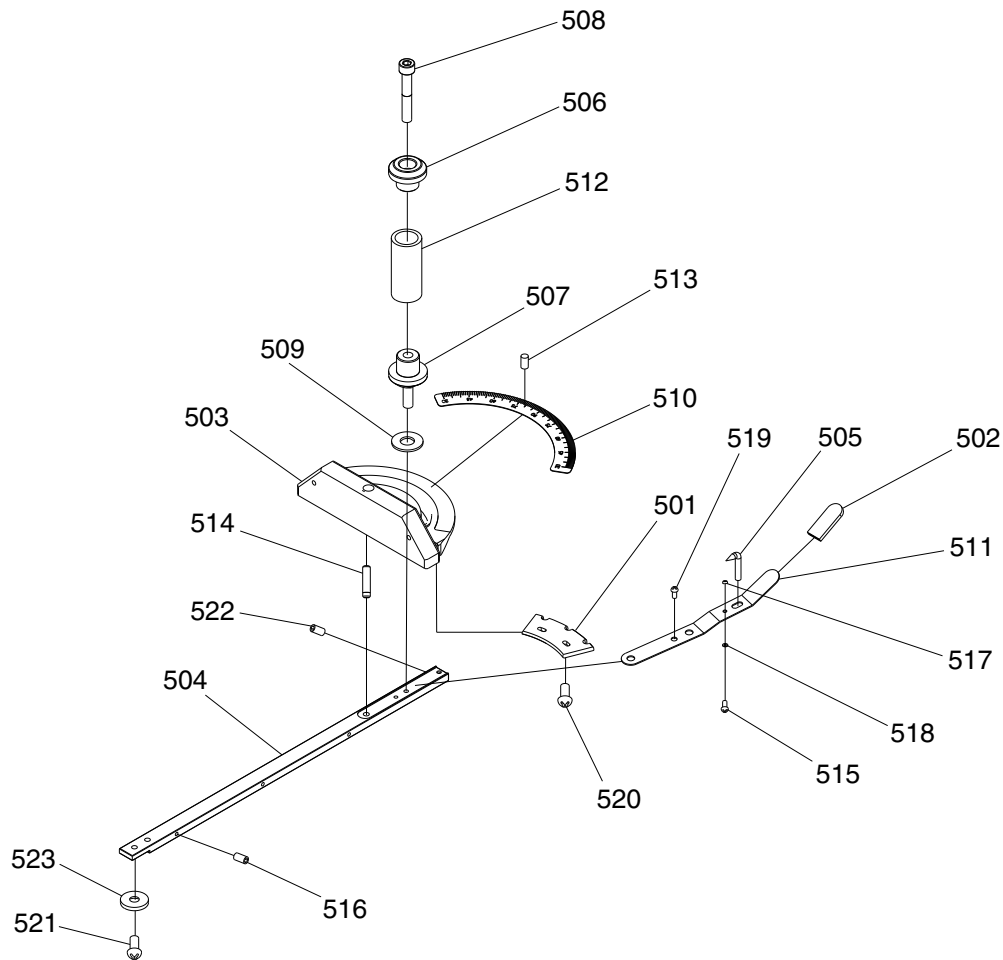

REF	PART #	DESCRIPTION
501	P0771501	FLAT PLATE
502	P0771502	SPRING PLATE COVER
503	P0771503	MITER GAUGE BODY
504	P0771504	MITER BAR
505	P0771505	ANGLE INDICATOR
506	P0771506	UPPER HANDLE CAP
507	P0771507	LOWER HANDLE CAP
508	P0771508	CAP SCREW M8-1.25 X 50
509	P0771509	HANDLE WASHER 6 X 20
510	P0771510	MITER SCALE
511	P0771511	SPRING PLATE
512	P0771512	MITER HANDLE

REF	PART #	DESCRIPTION
513	P0771513	RIVET
514	P0771514	MITER PIN
515	P0771515	FLAT HD SCR 4-40 X 3/16
516	P0771516	SET SCREW 10-24 X 1/2
517	P0771517	THREADED STOP PIN
518	P0771518	FLAT WASHER 3MM
519	P0771519	PHLP HD SCR 10-32 X 1/4
520	P0771520	PHLP HD SCR 6-32 X 7/16
521	P0771521	FLAT HD SCR 1/4-28 X 5/16
522	P0771522	SET SCREW 10-32 X 1/4
523	P0771523	MITER BAR GUIDE WASHER



# Labels & Cosmetics

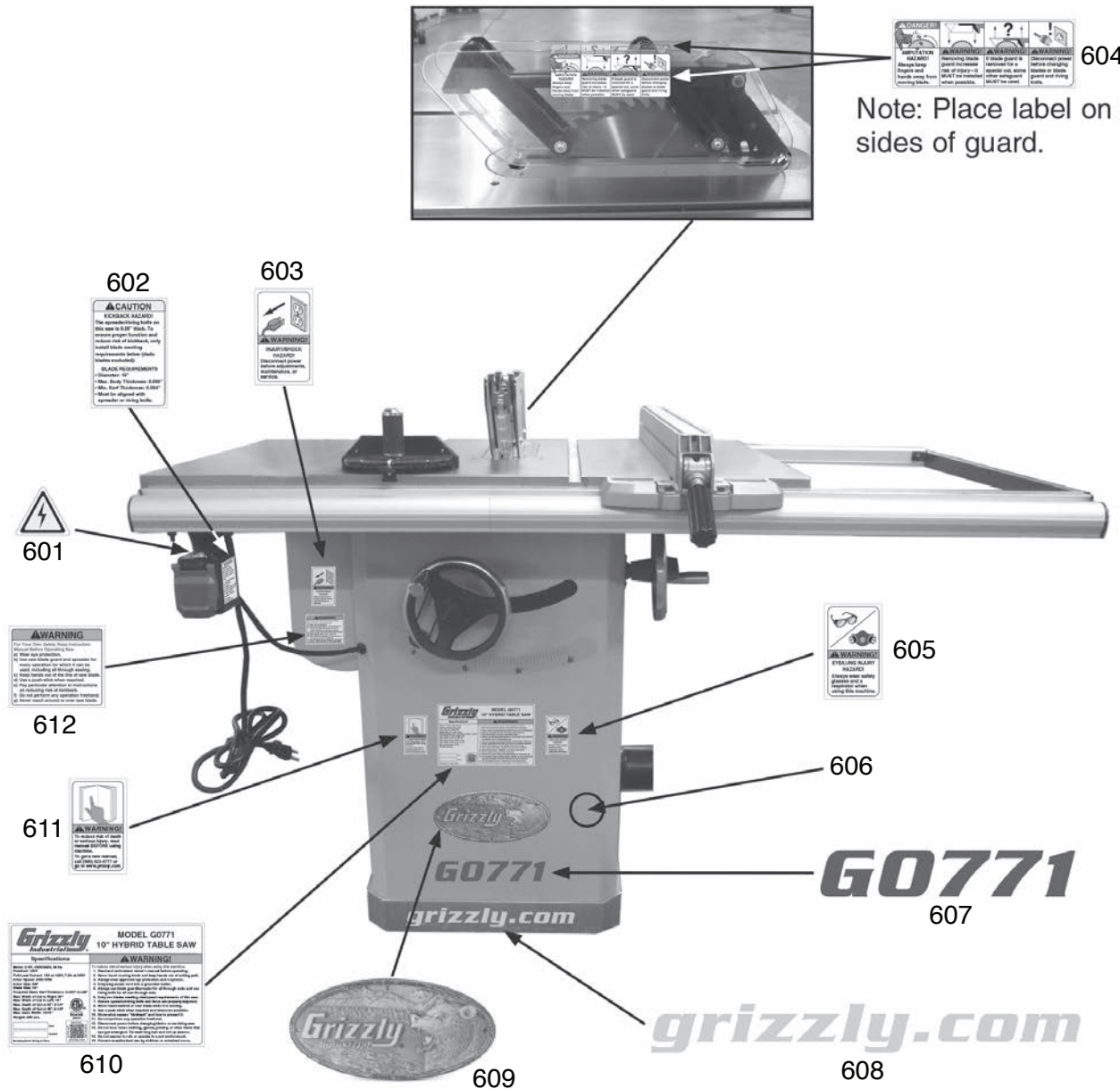

Note: Place label on both sides of guard.

REF PART #	DESCRIPTION
601	P0771601 ELECTRICITY LABEL
602	P0771602 SPREADER/RIVING PRECAUTION LABEL
603	P0771603 DISCONNECT POWER LABEL
604	P0771604 BLADE GUARD LABEL
605	P0771605 EYE/LUNG HAZARD LABEL
606	P0771606 GRIZZLY BEIGE TOUCH-UP PAINT

REF PART #	DESCRIPTION
607	P0771607 MODEL NUMBER LABEL
608	P0771608 GRIZZLY.COM LABEL
609	P0771609 GRIZZLY NAMEPLATE G8588
610	P0771610 MACHINE ID LABEL
611	P0771611 READ MANUAL LABEL
612	P0771612 TABLESAW WARNING LABEL

## **!WARNING**

Safety labels help reduce the risk of serious injury caused by machine hazards. If any label comes off or becomes unreadable, the owner of this machine **MUST** replace it in the original location before resuming operations. For replacements, contact (800) 523-4777 or [www.grizzly.com](http://www.grizzly.com).







# WARRANTY CARD

Name \_\_\_\_\_  
 Street \_\_\_\_\_  
 City \_\_\_\_\_ State \_\_\_\_\_ Zip \_\_\_\_\_  
 Phone # \_\_\_\_\_ Email \_\_\_\_\_  
 Model # \_\_\_\_\_ Order # \_\_\_\_\_ Serial # \_\_\_\_\_

The following information is given on a voluntary basis. It will be used for marketing purposes to help us develop better products and services. **Of course, all information is strictly confidential.**

- How did you learn about us?
 

<input type="checkbox"/> Advertisement	<input type="checkbox"/> Friend	<input type="checkbox"/> Catalog
<input type="checkbox"/> Card Deck	<input type="checkbox"/> Website	<input type="checkbox"/> Other:
- Which of the following magazines do you subscribe to?
 

<input type="checkbox"/> Cabinetmaker & FDM	<input type="checkbox"/> Popular Science	<input type="checkbox"/> Wooden Boat
<input type="checkbox"/> Family Handyman	<input type="checkbox"/> Popular Woodworking	<input type="checkbox"/> Woodshop News
<input type="checkbox"/> Hand Loader	<input type="checkbox"/> Precision Shooter	<input type="checkbox"/> Woodsmith
<input type="checkbox"/> Handy	<input type="checkbox"/> Projects in Metal	<input type="checkbox"/> Woodwork
<input type="checkbox"/> Home Shop Machinist	<input type="checkbox"/> RC Modeler	<input type="checkbox"/> Woodworker West
<input type="checkbox"/> Journal of Light Cont.	<input type="checkbox"/> Rifle	<input type="checkbox"/> Woodworker's Journal
<input type="checkbox"/> Live Steam	<input type="checkbox"/> Shop Notes	<input type="checkbox"/> Other:
<input type="checkbox"/> Model Airplane News	<input type="checkbox"/> Shotgun News	
<input type="checkbox"/> Old House Journal	<input type="checkbox"/> Today's Homeowner	
<input type="checkbox"/> Popular Mechanics	<input type="checkbox"/> Wood	
- What is your annual household income?
 

<input type="checkbox"/> \$20,000-\$29,000	<input type="checkbox"/> \$30,000-\$39,000	<input type="checkbox"/> \$40,000-\$49,000
<input type="checkbox"/> \$50,000-\$59,000	<input type="checkbox"/> \$60,000-\$69,000	<input type="checkbox"/> \$70,000+
- What is your age group?
 

<input type="checkbox"/> 20-29	<input type="checkbox"/> 30-39	<input type="checkbox"/> 40-49
<input type="checkbox"/> 50-59	<input type="checkbox"/> 60-69	<input type="checkbox"/> 70+
- How long have you been a woodworker/metalworker?
 

<input type="checkbox"/> 0-2 Years	<input type="checkbox"/> 2-8 Years	<input type="checkbox"/> 8-20 Years	<input type="checkbox"/> 20+ Years
------------------------------------	------------------------------------	-------------------------------------	------------------------------------
- How many of your machines or tools are Grizzly?
 

<input type="checkbox"/> 0-2	<input type="checkbox"/> 3-5	<input type="checkbox"/> 6-9	<input type="checkbox"/> 10+
------------------------------	------------------------------	------------------------------	------------------------------
- Do you think your machine represents a good value?  Yes  No
- Would you recommend Grizzly Industrial to a friend?  Yes  No
- Would you allow us to use your name as a reference for Grizzly customers in your area?  
**Note: We never use names more than 3 times.**  Yes  No

10. Comments: \_\_\_\_\_  
 \_\_\_\_\_  
 \_\_\_\_\_  
 \_\_\_\_\_

CUT ALONG DOTTED LINE

FOLD ALONG DOTTED LINE

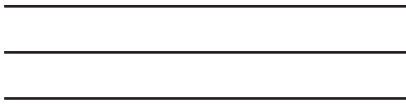

Place  
Stamp  
Here



GRIZZLY INDUSTRIAL, INC.  
P.O. BOX 2069  
BELLINGHAM, WA 98227-2069



FOLD ALONG DOTTED LINE

Send a Grizzly Catalog to a friend:

Name	_____
Street	_____
City	_____ State _____ Zip _____

TAPE ALONG EDGES--PLEASE DO NOT STAPLE

# WARRANTY & RETURNS

---

Grizzly Industrial, Inc. warrants every product it sells for a period of **1 year** to the original purchaser from the date of purchase. This warranty does not apply to defects due directly or indirectly to misuse, abuse, negligence, accidents, repairs or alterations or lack of maintenance. This is Grizzly's sole written warranty and any and all warranties that may be implied by law, including any merchantability or fitness, for any particular purpose, are hereby limited to the duration of this written warranty. We do not warrant or represent that the merchandise complies with the provisions of any law or acts unless the manufacturer so warrants. In no event shall Grizzly's liability under this warranty exceed the purchase price paid for the product and any legal actions brought against Grizzly shall be tried in the State of Washington, County of Whatcom.

We shall in no event be liable for death, injuries to persons or property or for incidental, contingent, special, or consequential damages arising from the use of our products.

To take advantage of this warranty, contact us by mail or phone and give us all the details. We will then issue you a "Return Number," which must be clearly posted on the outside as well as the inside of the carton. We will not accept any item back without this number. Proof of purchase must accompany the merchandise.

The manufacturers reserve the right to change specifications at any time because they constantly strive to achieve better quality equipment. We make every effort to ensure that our products meet high quality and durability standards and we hope you never need to use this warranty.

Please feel free to write or call us if you have any questions about the machine or the manual.

Thank you again for your business and continued support. We hope to serve you again soon.

# *grizzly.com*<sup>®</sup>

**TOOL WEBSITE**

Buy Direct and Save with Grizzly<sup>®</sup> – Trusted, Proven and a Great Value!  
~Since 1983~

*Visit Our Website Today For  
Current Specials!*

**ORDER  
24 HOURS A DAY!  
1-800-523-4777**



## Free Manuals Download Website

<http://myh66.com>

<http://usermanuals.us>

<http://www.somanuals.com>

<http://www.4manuals.cc>

<http://www.manual-lib.com>

<http://www.404manual.com>

<http://www.luxmanual.com>

<http://aubethermostatmanual.com>

Golf course search by state

<http://golfingnear.com>

Email search by domain

<http://emailbydomain.com>

Auto manuals search

<http://auto.somanuals.com>

TV manuals search

<http://tv.somanuals.com>