

Grizzly *Industrial, Inc.*®

MODEL G0695 VS MILLING MACHINE WITH RAM HEAD OWNER'S MANUAL



COPYRIGHT © JULY, 2009 BY GRIZZLY INDUSTRIAL, INC., REVISED OCTOBER, 2010 (TS)
**WARNING: NO PORTION OF THIS MANUAL MAY BE REPRODUCED IN ANY SHAPE
OR FORM WITHOUT THE WRITTEN APPROVAL OF GRIZZLY INDUSTRIAL, INC.**
(FOR MODELS MANUFACTURED SINCE 9/10) #TRCRBLTSJB11908 PRINTED IN TAIWAN

WARNING!

This manual provides critical safety instructions on the proper setup, operation, maintenance and service of this machine/equipment.

Failure to read, understand and follow the instructions given in this manual may result in serious personal injury, including amputation, electrocution or death.

The owner of this machine/equipment is solely responsible for its safe use. This responsibility includes but is not limited to proper installation in a safe environment, personnel training and usage authorization, proper inspection and maintenance, manual availability and comprehension, application of safety devices, blade/cutter integrity, and the usage of personal protective equipment.

The manufacturer will not be held liable for injury or property damage from negligence, improper training, machine modifications or misuse.

WARNING!

Some dust created by power sanding, sawing, grinding, drilling, and other construction activities contains chemicals known to the State of California to cause cancer, birth defects or other reproductive harm. Some examples of these chemicals are:

- **Lead from lead-based paints.**
- **Crystalline silica from bricks, cement and other masonry products.**
- **Arsenic and chromium from chemically-treated lumber.**

Your risk from these exposures varies, depending on how often you do this type of work. To reduce your exposure to these chemicals: Work in a well ventilated area, and work with approved safety equipment, such as those dust masks that are specially designed to filter out microscopic particles.

Table of Contents

INTRODUCTION	2	SECTION 5: ACCESSORIES	30
Manual Accuracy	2	SECTION 6: MAINTENANCE	35
Contact Info.....	2	Schedule	35
Machine Description	2	Cleaning & Protecting	35
Identification.....	3	Lubrication	35
Machine Data Sheet	4	V-Belt Tensioning.....	37
SECTION 1: SAFETY	6	SECTION 7: SERVICE	38
Safety Instructions for Machinery	6	Troubleshooting	38
Additional Safety Instructions For Mills.....	8	Adjusting Gibs.....	40
Glossary of Terms	9	Adjusting Backlash.....	41
SECTION 2: CIRCUIT REQUIREMENTS	10	V-Belt Replacement.....	41
220V Single-Phase Operation	10	SECTION 8: WIRING	43
SECTION 3: SETUP	11	Wiring Safety Instructions	43
Needed for Setup.....	11	Wiring Diagram	44
Unpacking	11	Electrical Components	45
Inventory	12	SECTION 9: PARTS	46
Cleanup.....	13	Base, Column, & Knee Breakdown	46
Site Considerations.....	14	Head Breakdown	48
Moving & Placing Mill.....	15	Motor & Ram Breakdown.....	50
Mounting to Shop Floor	15	Table Breakdown	52
Assembly	16	Label Placement	54
Test Run	17	WARRANTY AND RETURNS	57
Spindle Break-In	18		
SECTION 4: OPERATIONS	19		
Basic Controls.....	19		
Operation Overview	22		
Table Movement	22		
Headstock Tilting	24		
Headstock Turret Rotation.....	26		
Headstock Ram Movement	27		
Setting Spindle Speed	28		
Loading/Unloading Tooling	29		

INTRODUCTION

Manual Accuracy

We are proud to offer this manual with your new machine! We've made every effort to be exact with the instructions, specifications, drawings, and photographs of the machine we used when writing this manual. However, sometimes we still make an occasional mistake.

Also, owing to our policy of continuous improvement, **your machine may not exactly match the manual**. If you find this to be the case, and the difference between the manual and machine leaves you in doubt, check our website for the latest manual update or call technical support for help.

Before calling, find the manufacture date of your machine by looking at the date stamped into the machine ID label (see below). This will help us determine if the manual version you received matches the manufacture date of your machine.

		MODEL GXXXX MACHINE NAME	
SPECIFICATIONS		WARNING!	
Motor:		Manufacture Date of Your Machine ing this machine: operation. s and respirator. sted/setup and suit before starting.	
Specification:			
Specification:			
Specification:			
Weight:			
<input type="text"/>	Date		
<input type="text"/>	Serial Number		
Manufactured for Grizzly in Taiwan			
4. make sure the motor has stopped and disconnect power before adjustments, maintenance, or service.			
5. DO NOT expose to rain or dampness.			
6. DO NOT modify this machine in any way.			
7. DO NOT remove safety guards.			
8. Never leave machine running unattended.			
9. DO NOT operate under the influence of drugs or alcohol.			
10. Maintain machine carefully to prevent accidents.			

For your convenience, we post all available manuals and manual updates for free on our website at www.grizzly.com. Any updates to your model of machine will be reflected in these documents as soon as they are complete.

Contact Info

We stand behind our machines. If you have any service questions, parts requests or general questions about the machine, please call or write us at the location listed below.

Grizzly Industrial, Inc.
1203 Lycoming Mall Circle
Muncy, PA 17756
Phone: (570) 546-9663
E-Mail: techsupport@grizzly.com

We want your feedback on this manual. If you can take the time, please email or write to us at the address below and tell us how we did:

Grizzly Industrial, Inc.
c/o Technical Documentation Manager
P.O. Box 2069
Bellingham, WA 98227-2069
Email: manuals@grizzly.com

Machine Description

The Model G0695 vertical mill is used to remove material from metal workpieces with the use of a rotating cutting tool.

During most operations, the workpiece is clamped to the table, then moved into the rotating cutter in any combination of three paths.

This mill uses a frequency drive to convert incoming 220V single-phase power to 220V 3-phase for efficient performance from the spindle motor. Power is transferred directly to the spindle from the motor by a V-belt and pulleys.

Spindle speed is electronically controlled by using the variable speed dial and readout on the control panel.



Identification

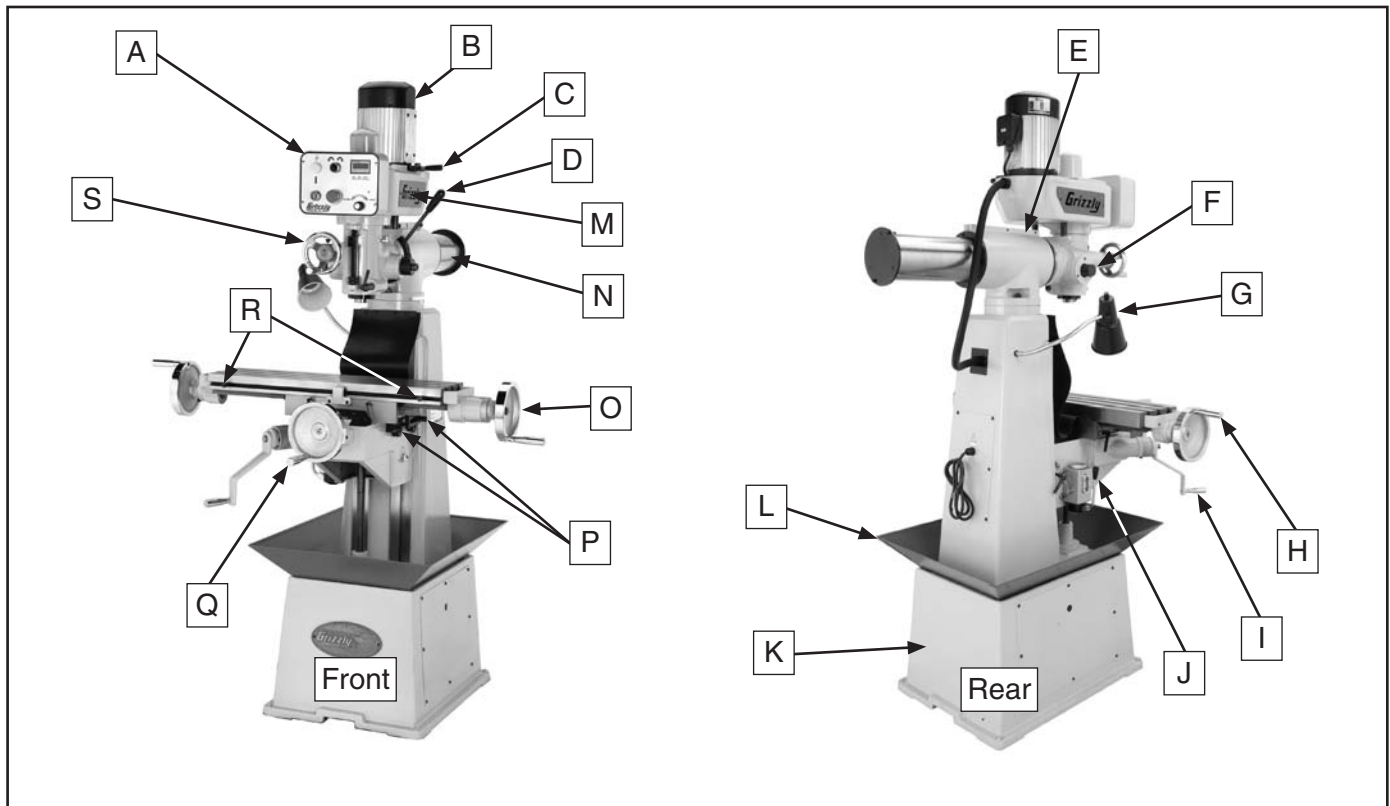
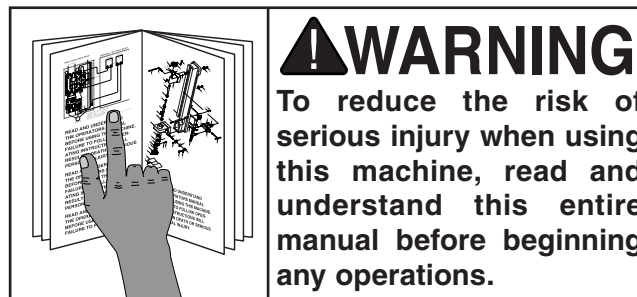

Figure 1. Model G0695 identification.

- | | |
|---------------------------------------------------------------|-------------------------------------------|
| A. Control Panel (refer to Page 19 for details) | K. Base |
| B. Motor 1½HP, 220V, 3-Phase | L. Splash Pan |
| C. V-Belt Belt Tension Lever and Lock Bolt | M. Belt Access Plate |
| D. Coarse Downfeed Handle | N. Headstock Ram |
| E. Turret | O. X-Axis Handwheel |
| F. Downfeed Selector | P. Cross (Y-Axis) Feed Limit Stops |
| G. Work Light 110V | Q. Y-Axis Handwheel |
| H. X-Axis Handwheel | R. Longitudinal Limit Stops |
| I. Z-Axis Crank Handle | S. Fine Downfeed Handwheel |
| J. One-Shot Oiler | |





MACHINE DATA SHEET

Customer Service #: (570) 546-9663 · To Order Call: (800) 523-4777 · Fax #: (800) 438-5901

MODEL G0695 VS MILLING MACHINE WITH RAM HEAD

Product Dimensions:

Weight..... 1070 lbs.
 Length/Width/Height..... 40-1/2 x 42-3/4 x 79 in.
 Foot Print (Length/Width)..... 19 x 26 in.

Shipping Dimensions:

Type..... Wood Crate
 Content..... Machine
 Weight..... 1200 lbs.
 Length/Width/Height..... 44 x 44 x 88 in.

Electrical:

Power Requirement..... 220V, Single-Phase, 60 Hz
 Minimum Circuit Size..... 15A
 Inverter Type..... Yaskawa RM5G-2001
 Inverter Size..... 1 HP
 Switch..... ON/OFF Magnetic
 Switch Voltage..... 220V, Single-Phase
 Recommended Plug/Outlet Type..... NEMA 6-15

Motors:

Main

Type..... Aluminum Cast TEFC Induction
 Horsepower..... 1-1/2 HP
 Voltage..... 220V
 Phase..... Three
 Amps..... 4.8A
 Speed..... 1725 RPM
 Cycle..... 60 Hz
 Power Transfer..... V-Belt Drive
 Bearings..... Shielded & Lubricated

Main Specifications:

Operation Info

Spindle Travel..... 3-1/2 in.
 Longitudinal Table Travel..... 18-1/2 in.
 Cross Table Travel..... 7-1/2 in.
 Vert. Table Travel..... 17-3/4 in.
 Ram Travel..... 11-1/2 in.
 Head Swivel..... 45 Left, 45 Right deg.
 Head Tilt..... 45 Left, 45 Right deg.
 Max. Dist Spindle To Column..... 7 in.
 Max. Dist Spindle To Table..... 2-1/4 - 20 in.
 Drilling Cap For Cast Iron..... 1 in.
 Drilling Cap For Steel..... 3/4 in.
 No. Of Vert. Spindle Speeds..... Variable
 Range Of Vert. Spindle Speeds..... 220 - 2250 RPM



Table Info

Table Length.....	30 in.
Table Width.....	8 in.
Table Thickness.....	2 in.
No. Of T Slots.....	3
T Slots Width.....	1/2 in.
T Slots Height.....	7/8 in.
T Slots Centers.....	2-3/16 in.
Stud Size.....	3/8 in.

Spindle Info

Spindle Taper.....	R-8
End Milling Cap.....	1 in.
Face Milling Cap.....	3 in.
Draw Bar Diameter.....	7/16 in.
Draw Bar TPI.....	20 TPI
Draw Bar Length.....	12-3/8 in.
Spindle Bearings.....	Angular Contact

Construction

Table Const.....	Hardened & Precision-Ground Cast Iron
Head Const.....	Cast Iron
Column Const.....	Cast Iron
Base Const.....	Cast Iron
Paint.....	Urethane

Other Specifications:

Country Of Origin	Taiwan
Warranty	1 Year
Serial Number Location	Machine ID Label on Side
Assembly Time	1 Hour

Features:

- One-Shot Lubrication
- High Precision Ball Bearings
- Bronze Nut on Longitudinal and Cross Feed Leadscrews
- Variable Frequency Drive Speed Controls
- Hardened and Precision Ground Leadscrews
- Runs on Single-Phase Power Using a 3-Phase Inverter



SECTION 1: SAFETY

WARNING

For Your Own Safety, Read Instruction Manual Before Operating this Machine

The purpose of safety symbols is to attract your attention to possible hazardous conditions. This manual uses a series of symbols and signal words intended to convey the level of importance of the safety messages. The progression of symbols is described below. Remember that safety messages by themselves do not eliminate danger and are not a substitute for proper accident prevention measures.



Indicates an imminently hazardous situation which, if not avoided, **WILL** result in death or serious injury.



Indicates a potentially hazardous situation which, if not avoided, **COULD** result in death or serious injury.



Indicates a potentially hazardous situation which, if not avoided, **MAY** result in minor or moderate injury. It may also be used to alert against unsafe practices.

NOTICE

This symbol is used to alert the user to useful information about proper operation of the machine.

WARNING

Safety Instructions for Machinery

OWNER'S MANUAL. Read and understand this owner's manual **BEFORE** using machine. Untrained users can be seriously hurt.

EYE PROTECTION. Always wear ANSI-approved safety glasses or a face shield when operating or observing machinery. to reduce the risk of eye injury or blindness from flying particles Everyday eyeglasses are not approved safety glasses.

HAZARDOUS DUST. Dust created while using machinery may cause cancer, birth defects, or long-term respiratory damage. Be aware of dust hazards associated with each workpiece material, and always wear a NIOSH-approved respirator to reduce your risk.

WEARING PROPER APPAREL. Do not wear clothing, apparel, or jewelry that can become entangled in moving parts. Always tie back or cover long hair. Wear non-slip footwear to avoid accidental slips which could cause a loss of workpiece control.

HEARING PROTECTION. Always wear hearing protection when operating or observing loud machinery. Extended exposure to this noise without hearing protection can cause permanent hearing loss.

MENTAL ALERTNESS. Be mentally alert when running machinery. Never operate under the influence of drugs or alcohol, when tired, or when distracted.



WARNING

Safety Instructions for Machinery

DISCONNECTING POWER SUPPLY. Always disconnect machine from power supply before servicing, adjusting, or changing cutting tools (bits, blades, cutters, etc.). Make sure switch is in OFF position before reconnecting to avoid an unexpected or unintentional start.

INTENDED USE. Only use the machine for its intended purpose and only use recommended accessories. Never stand on machine, modify it for an alternative use, or outfit it with non-approved accessories.

STABLE MACHINE. Unexpected movement during operations greatly increases the risk of injury and loss of control. Verify machines are stable/secure and mobile bases (if used) are locked before starting.

FORCING MACHINERY. Do not force machine. It will do the job safer and better at the rate for which it was designed.

GUARDS & COVERS. Guards and covers can protect you from accidental contact with moving parts or flying debris. Make sure they are properly installed, undamaged, and working correctly before using machine.

REMOVING TOOLS. Never leave adjustment tools, chuck keys, wrenches, etc. in or on machine—especially near moving parts. Verify removal before starting!

AWKWARD POSITIONS. Keep proper footing and balance at all times when operating machine. Do not overreach! Avoid awkward hand positions that make workpiece control difficult or increase the risk of accidental injury.

DANGEROUS ENVIRONMENTS. Do not use machinery in wet locations, cluttered areas, around flammables, or in poorly-lit areas. Keep work area clean, dry, and well lighted to minimize risk of injury.

APPROVED OPERATION. Untrained operators can be seriously hurt by machinery. Only allow trained or properly supervised people to use machine. When machine is not being used, disconnect power, remove switch keys, or lock-out machine to prevent unauthorized use—especially around children. Make workshop kid proof!

CHILDREN & BYSTANDERS. Keep children and bystanders a safe distance away from work area. Stop using machine if children or bystanders become a distraction.

FEED DIRECTION. Unless otherwise noted, feed work against the rotation of blades or cutters. Feeding in the same direction of rotation may pull your hand into the cut.

SECURING WORKPIECE. When required, use clamps or vises to secure workpiece. A secured workpiece protects hands and frees both of them to operate the machine.

UNATTENDED OPERATION. Never leave machine running while unattended. Turn machine **OFF** and ensure all moving parts completely stop before walking away.

MAINTENANCE & INSPECTION. A machine that is not properly maintained may operate unpredictably. Follow all maintenance instructions and lubrication schedules to keep machine in good working condition. Regularly inspect machine for loose bolts, alignment of critical parts, binding, or any other conditions that may affect safe operation. Always repair or replace damaged or mis-adjusted parts before operating machine.

EXPERIENCING DIFFICULTIES. If at any time you are experiencing difficulties performing the intended operation, stop using the machine! Contact our Technical Support Department at (570) 546-9663.



WARNING

Additional Safety Instructions For Mills

- 1. UNDERSTANDING CONTROLS.** Make sure you understand the use and operation of all controls before operating machine.
- 2. SAFETY ACCESSORIES.** Always use a chip guard in addition to your safety glasses, or use a face shield when milling to reduce the risk of injury from flying chips.
- 3. WORK HOLDING.** Before starting the machine, be certain the workpiece has been properly clamped to the table. If the workpiece comes loose during operation, serious injury or property damage could occur. NEVER hold the workpiece by hand during operation.
- 4. CHUCK KEY SAFETY.** Always remove chuck key, drawbar wrench, and any service tools immediately after use and before starting the mill to prevent them from being thrown at yourself or bystanders.
- 5. SPINDLE SPEEDS.** To reduce the risk injury from the tool or workpiece breaking apart, always select the spindle speed that is appropriate for the type of work and material. Allow the mill to reach full speed before beginning a cut.
- 6. STOPPING SPINDLE.** To avoid laceration or abrasion injuries, DO NOT stop the spindle by putting your hand on it. Allow the spindle to stop on its own, or in the case of an emergency, use the spindle brake.
- 7. CLEAN-UP.** The chips produced during operation are hot and sharp. DO NOT clear chips by hand or compressed air. Use a brush or vacuum, and never clear chips while the spindle is turning.
- 8. MACHINE CARE AND MAINTENANCE.** Never operate the mill with damaged or worn parts. Maintain your mill in proper working condition. Perform routine inspections and maintenance promptly. Put away adjustment tools after use.
- 9. TOOL HOLDING.** Always use the proper tools for your operation. To avoid having a cutting tool be thrown from the mill at a high rate or speed, make sure it is properly and firmly installed.
- 10. CUTTING TOOL INSPECTION.** To avoid the risk of injury from shattering cutting tools, always inspect cutting tools for sharpness, chips, or cracks before each use. Replace dull, chipped, or cracked cutting tools immediately. Handle new cutting tools with care. Leading edges are very sharp and can cause lacerations.
- 11. POWER DISRUPTION.** In the event of a local power outage during operation, turn **OFF** all switches to avoid possible sudden startup once power is restored.

WARNING

Like all machinery there is potential danger when operating this mill. Accidents are frequently caused by lack of familiarity or failure to pay attention. Use this mill with respect and caution to reduce the risk of operator injury. If normal safety precautions are overlooked or ignored, serious personal injury may occur.

CAUTION

No list of safety guidelines can be complete. Every shop environment is different. Always consider safety first, as it applies to your individual working conditions. Use this and other machinery with caution and respect. Failure to do so could result in serious personal injury, damage to equipment, or poor work results.



Glossary of Terms

The following is a list of common definitions, terms and phrases used throughout this manual as they relate to this mill and metalworking in general. Become familiar with these terms for assembling, adjusting and operating this mill. Your safety is **VERY** important to us at Grizzly!

Arbor: A tapered shaft that holds a cutting tool.

Collet: A tapered shaped split-sleeve bushing that holds round tools by their outside diameter.

Cutting Speed: The distance a point on a cutter moves in one minute, expressed in surface meters or feet per minute.

Dial Indicator: An instrument used in setup and inspection work that shows the amount of error in size or alignment of a part.

Dividing Head: A milling machine accessory used to divide a circular object into a number of equal parts.

Down or Climb Milling: Feeding the workpiece in the same or opposite direction as the cutter rotation.

End Milling: The operation of machining flat surfaces either horizontal, vertical, or at an angle using an end mill as a cutter.

Face Milling: The milled surface in this method results from the combined action of cutting edges located on the face or end of the cutting tools.

Milling Feed: This is the product of multiplying the desired chip size by the number of teeth on the cutter and the cutter RPM. It is usually measured in inches per minute.

Fixture: A device that securely holds the workpiece in place during a cutting operation.

Form Milling: The machining of irregular contours by using form cutters.

Gang Milling: When more than two cutters are mounted on the arbor to machine surfaces of a workpiece.

Gib: A piece of metal placed along a sliding member to take up wear or to ensure a proper fit.

Headstock: The component that houses the vertical spindle, motor, and drive system.

Knee: The component upon which the saddle and table are mounted and which can move vertically.

Lead Screw: The threaded shaft that moves the table along the X-axis, Y-axis, and Z-axis paths.

Peripheral Milling: The milled surface is produced by cutting teeth located on the outer edge of the cutter body.

Headstock Ram: The component that holds the headstock and moves in a linear path across the column.

Saddle: The sliding component that holds the table and moves along the Y-axis path.

Side Milling: The operation of machining a vertical surface on the side of a workpiece using a side milling cutter.

Slitting and Cutting Off: Metal slitting saws are used for milling narrow slots and for cutting off stock.

Spindle: The rotating hollow shaft that transfers the driving force from the motor to the tooling.

Turret: The top part of the column on which the ram rotates.

Ways: The precision-machined, flat tracks on which the table, saddle, and knee travel.

X-Axis: The path the table travels left-to-right.

Y-Axis: The path the table travels in or out.

Z-Axis: The path the table travels up or down.



SECTION 2: CIRCUIT REQUIREMENTS

220V Single-Phase Operation

!WARNING

Serious personal injury could occur if you connect the machine to power before completing the setup process. **DO NOT** connect the machine to the power until instructed later in this manual.



!WARNING

Electrocution or fire could result if machine is not grounded and installed in compliance with electrical codes. Compliance **MUST** be verified by a qualified electrician!

Full Load Amperage Draw

This machine draws the following amps under maximum load:

Amp Draw..... 4.8 Amps

Power Supply Circuit Requirements

The power supply circuit for your machine **MUST** be grounded and rated for the amperage given below. Never replace a circuit breaker on an existing circuit with one of higher amperage without consulting a qualified electrician to ensure compliance with wiring codes. **If you are unsure about the wiring codes in your area or you plan to connect your machine to a shared circuit, consult a qualified electrician.**

Minimum Circuit Size..... 15 Amps

Power Connection Device

The type of plug required to connect your machine to power depends on the type of service you currently have or plan to install. We recommend using the plug shown in **Figure 2**.

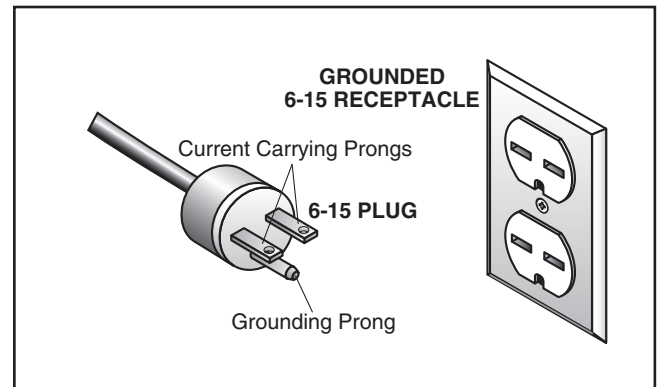

Figure 2. NEMA 6-15 plug and receptacle.

Extension Cords

Using extension cords may reduce the life of the motor. Instead, place the machine near a power source. If you must use an extension cord:

- Use at least a 14 gauge cord that does not exceed 50 feet in length!
- The extension cord must also have a ground wire and plug pin.
- A qualified electrician **MUST** size cords over 50 feet long to prevent motor damage.



SECTION 3: SETUP

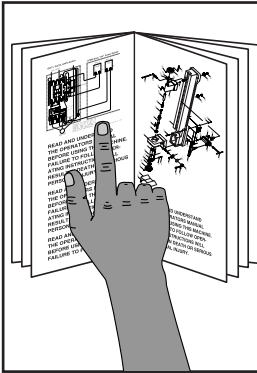

!WARNING

This machine presents serious injury hazards to untrained users. Read through this entire manual to become familiar with the controls and operations before starting the machine!

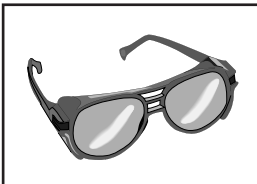

!WARNING

Wear safety glasses during the entire setup process!

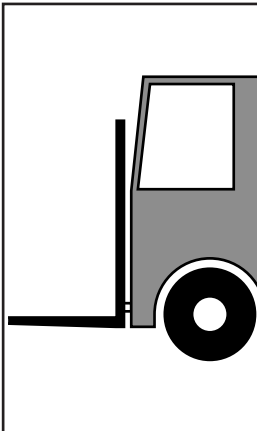

!WARNING

The Model G0695 is a heavy machine. Serious personal injury may occur if safe moving methods are not used. To be safe, get assistance and use power equipment to move the shipping crate and remove the machine from the pallet.

Needed for Setup

The following items are needed to complete the setup process, but are not included with your machine:

Description	Qty
• Other People	2
• Precision Level	1
• Safety Glasses	1 Per Person
• Wrench 1/2"	1
• External Retaining Ring Pliers	1
• Lifting Straps (rated for at least 1500 lbs.).....	2
• Power Lifting Equipment (rated for at least 1500 lbs.).....	1
• Machine Mounting Hardware	As Needed
• Cleaning Solvent & Rags	As Needed

Unpacking

Your machine was carefully packaged for safe transportation. Remove the sides of the crate and then the packaging materials from around your machine. Inspect the machine. If you discover the machine is damaged, *please immediately call Customer Service at (570) 546-9663 for advice.*

Save the containers and all packing materials for possible inspection by the carrier or its agent. *Otherwise, filing a freight claim can be difficult.*

When you are completely satisfied with the condition of your shipment, inventory the contents.



Inventory

The following is a description of the main components shipped with your machine. Lay the components out to inventory them.

Note: *If you can't find an item on this list, check the mounting location on the machine or examine the packaging materials carefully. Occasionally we pre-install certain components for shipping purposes.*

Inventory: (Figure 3)	Qty
A. Cap Screws M6-1 x 25.....	3
B. Handwheel Handles.....	3
C. Hex Wrench 5mm.....	1
D. Hex Wrench 4mm.....	1

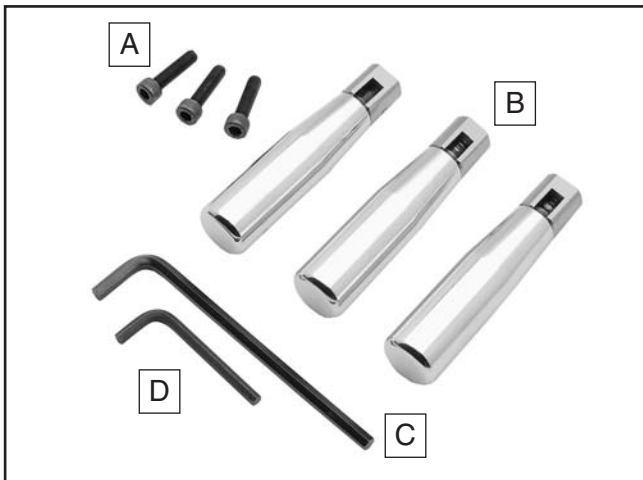
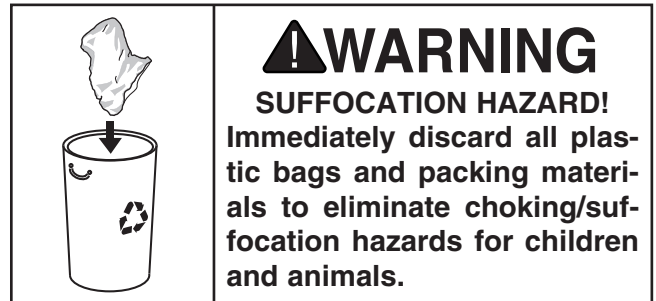

Figure 3. Model G0695 inventory.

If any nonproprietary parts are missing (e.g. a nut or a washer), we will gladly replace them; or for the sake of expediency, replacements can be obtained at your local hardware store.



! WARNING
SUFFOCATION HAZARD!
Immediately discard all plastic bags and packing materials to eliminate choking/suffocation hazards for children and animals.



Cleanup

The unpainted surfaces of your machine are coated with a heavy-duty rust preventative that prevents corrosion during shipment and storage.

This rust preventative has been your machine's close ally and guardian since it left the factory. If your machine arrived to you free of rust, then be thankful that the rust preventative protected it during its journey...and try to stay thankful as you clean it off, because it can be challenging to remove if you are unprepared and impatient.

Plan on spending some time cleaning your machine. The time you spend doing this will reward you with smooth sliding parts and a better appreciation for the proper care of your machine's unpainted surfaces.

Although there are many ways to successfully remove the rust preventative, these instructions walk you through what works well for us.

Before cleaning, gather the following:

- Disposable Rags
- Cleaner/degreaser (see below)
- Safety glasses & disposable gloves

H9692—Orange Power Cleaner & Degreaser

One of the best cleaners we've found for quickly and easily removing rust preventative.



Figure 4. Model H9692 Industrial Orange Power Cleaner/Degreaser (99.9% biodegradable).

Note: *In a pinch, automotive degreasers, mineral spirits or WD•40 can be used to remove rust preventative. Before using these products, though, test them on an inconspicuous area of your paint to make sure they will not damage it.*

Model G0695 (Mfg. Since 9/10)

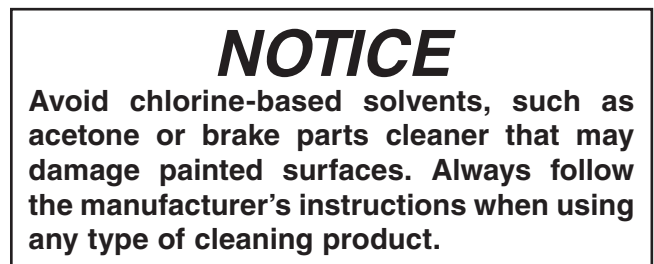
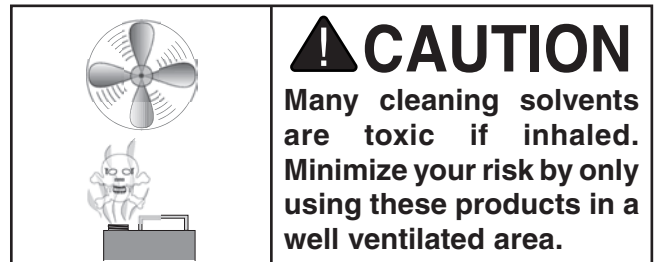
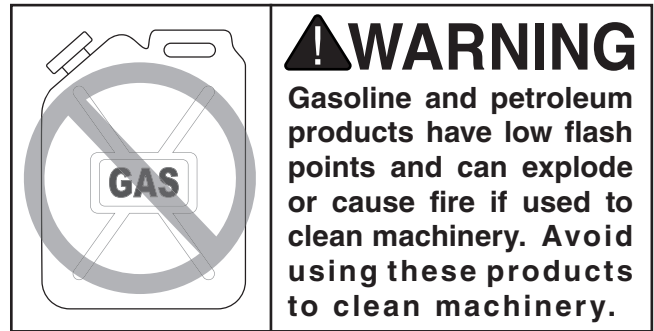

Basic steps for removing rust preventative:

1. Put on safety glasses and disposable gloves.
2. Coat all surfaces that have rust preventative with a liberal amount of your cleaner/degreaser and let them soak for few minutes.

3. Wipe off the surfaces. If your cleaner/degreaser is effective, the rust preventative will wipe off easily.

Note: *To clean off thick coats of rust preventative on flat surfaces, such as tables, use a PLASTIC paint scraper to scrape off the majority of the coating before wiping it off with your rag. (Do not use a metal scraper or you may scratch your machine.)*

4. Repeat **Steps 2–3** as necessary until clean, then coat all unpainted surfaces with a quality metal protectant to prevent rust.



Site Considerations

Weight Load

Refer to the **Machine Data Sheet** for the weight of your machine. Make sure that the surface upon which the machine is placed will bear the weight of the machine, additional equipment that may be installed on the machine, and the heaviest workpiece that will be used. Additionally, consider the weight of the operator and any dynamic loading that may occur when operating the machine.

Space Allocation

Consider the largest size of workpiece that will be processed through this machine and provide enough space around the machine for adequate operator material handling or the installation of auxiliary equipment. With permanent installations, leave enough space around the machine to open or remove doors/covers as required by the maintenance and service described in this manual. **See below for required space allocation.**



Physical Environment

The physical environment where your machine is operated is important for safe operation and the longevity of its components. For best results, operate this machine in a dry environment that is free from excessive moisture, hazardous chemicals, airborne abrasives, or extreme conditions. Extreme conditions for this type of machinery are generally those where the ambient temperature range exceeds 41°–104°F; the relative humidity range exceeds 20–95% (non-condensing); or the environment is subject to vibration, shocks, or bumps.

Electrical Installation

Place this machine near an existing power source. Make sure all power cords are protected from traffic, material handling, moisture, chemicals, or other hazards. Make sure to leave access to a means of disconnecting the power source or engaging a lockout/tagout device.

Lighting

Lighting around the machine must be adequate enough that operations can be performed safely. Shadows, glare, or strobe effects that may distract or impede the operator must be eliminated.

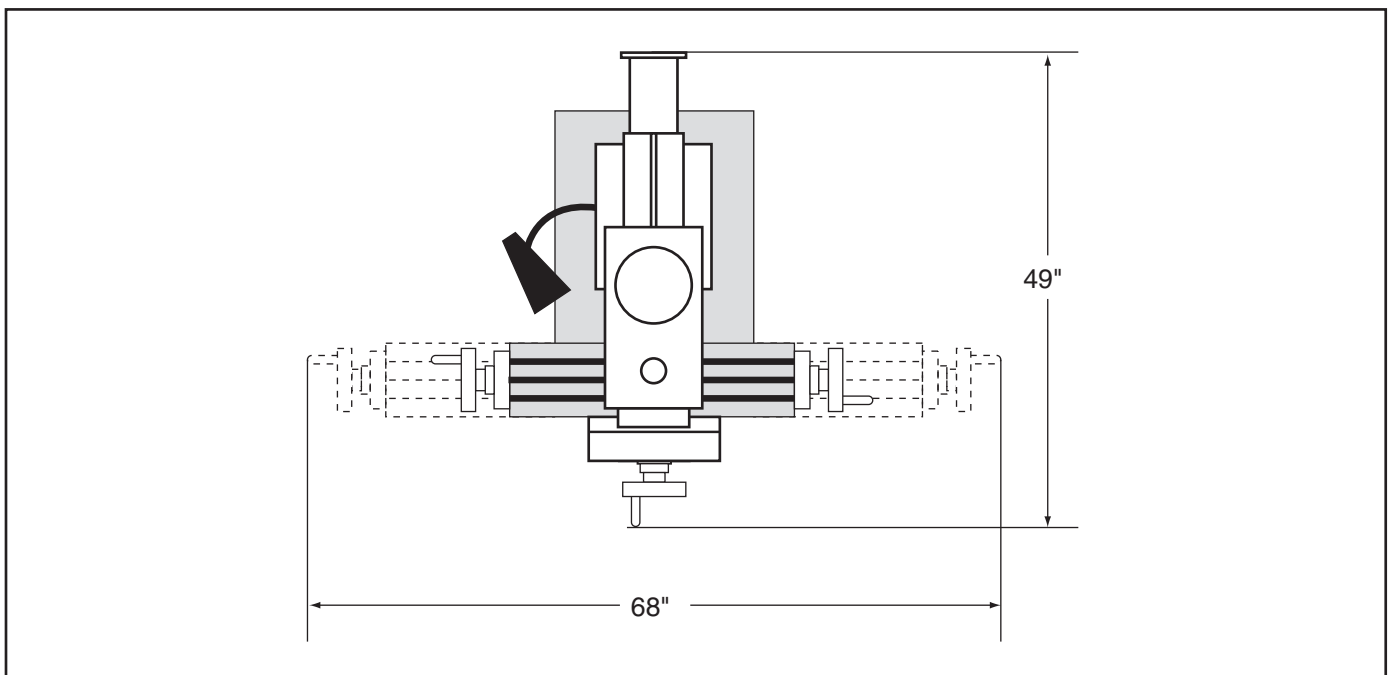
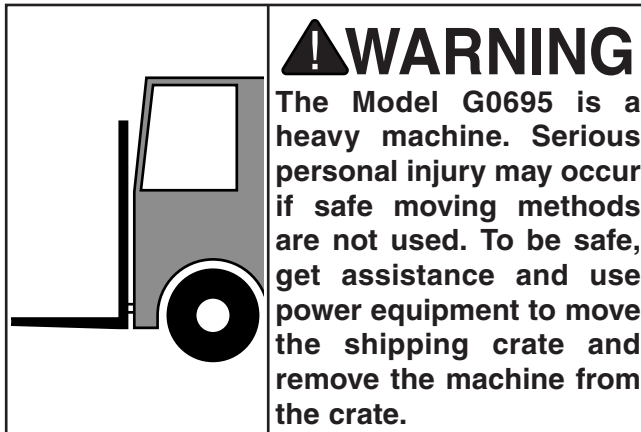

Figure 5. Minimum working clearances.



Moving & Placing Mill



To move and place your mill:

1. After removing the crate sides from the shipping pallet, adjust the headstock and table as close to the mill body as possible, and install the lifting straps as shown in **Figure 6**.

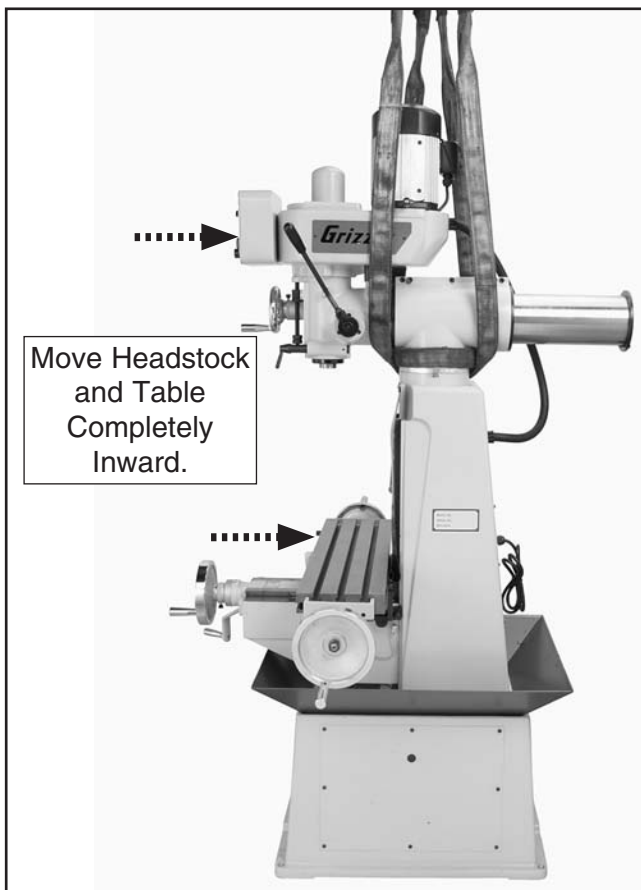

Figure 6. Lifting straps positioned.

2. Use a 1/2" wrench to unbolt the mill from the pallet.
3. Have another person steady the machine to keep it from swaying and lift it just enough to clear the pallet and floor obstacles, then move it to the prepared location.
4. When mounting the machine to the floor, use a precision level to make sure the table is level from side-to-side and front-to-back.

Note: *If necessary, use shims to make sure there are no gaps between the base and the floor to avoid cracking or warping the cast iron.*

Mounting to Shop Floor

Although not required, we recommend that you mount your new machine to the floor. Because this is an optional step and floor materials may vary, floor mounting hardware is not included. Generally, you can either bolt your machine to the floor or mount it on machine mounts. Both options are described below. Whichever option you choose, it is necessary to level your machine with a precision level.

NOTICE

Anchor studs are stronger and more permanent alternatives to lag shield anchors; however, they will stick out of the floor, which may cause a tripping hazard if you decide to move your machine.

NOTICE

We strongly recommend securing your machine to the floor if it is hardwired to the power source. Consult with your electrician to ensure compliance with local codes.



Bolting to Concrete Floors

Anchor studs and lag shield anchors with lag bolts (see **Figure 7**) are two popular methods for anchoring an object to a concrete floor. We suggest you research the many options and methods for mounting your machine and choose the best that fits your specific application.

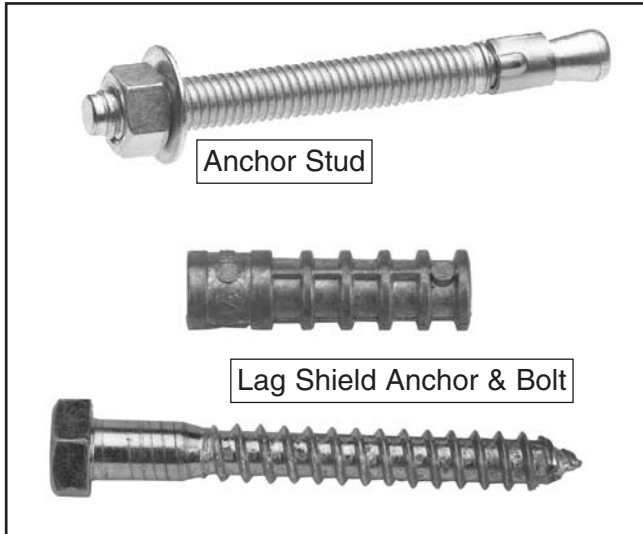

Figure 7. Typical fasteners for mounting to concrete floors.

Using Machine Mounts

Using machine mounts, shown in **Figure 8**, gives the advantage of fast leveling and vibration reduction. The large size of the foot pads distributes the weight of the machine to reduce strain on the floor.



Figure 8. Machine mount example.

Assembly

To assemble your mill:

1. Secure the three handles to the handwheels with the M6-1 x 25 cap screws, as shown in **Figure 9**.

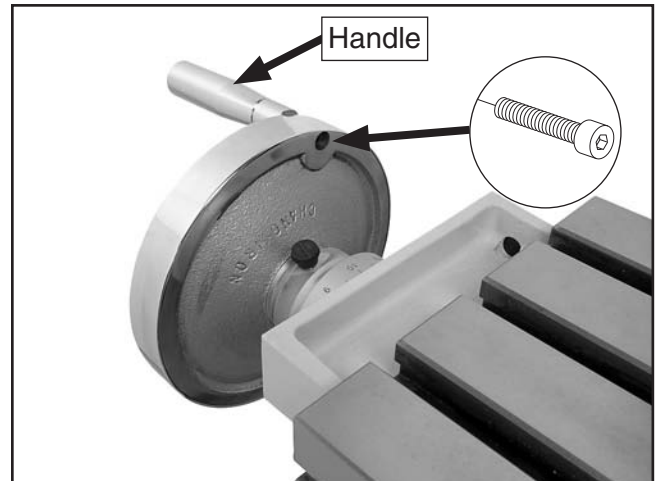

Figure 9. Handle attached to handwheel.

2. Use the external retaining ring pliers to remove the retaining ring from the end of the vertical crank screw, reverse the crank handle from its shipping position, then re-install the retaining ring (see **Figure 10**).

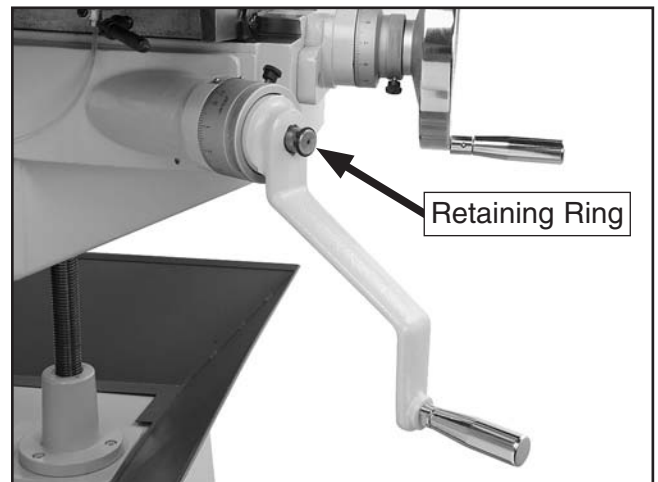

Figure 10. Vertical crank handle properly installed.

Test Run

Once the assembly is complete, test run your machine to make sure it runs properly and is ready for regular operation. The test run consists of verifying the following: 1) The motor powers up and runs correctly and 2) the stop button safety feature works correctly.

If, during the test run, you cannot easily locate the source of an unusual noise or vibration, stop using the machine immediately, then review **Troubleshooting on Page 38**.

If you cannot find a remedy, contact our Tech Support at (570) 546-9663 for assistance.

WARNING

Before starting the mill, make sure you have performed the preceding assembly instructions, and you have read through the rest of the manual and are familiar with the various functions and safety features on this machine. Failure to follow this warning could result in serious personal injury or even death!

To test run the machine:

1. Make sure you understand the safety instructions at the beginning of the manual and that the machine is set up properly.
2. Make sure all tools and objects used during setup are cleared away from the machine.
3. Make sure the machine is lubricated (refer to **Lubrication on Page 35** for detailed instructions).
4. Refer to **Basic Controls on Page 19** to become familiar with the control panel functions.
5. Connect the machine to the power source—the power lamp on the control panel should light.

6. Push the stop button in, then twist it clockwise so it pops out. When the stop button pops out, the switch is reset and ready for operation (see **Figure 11**).

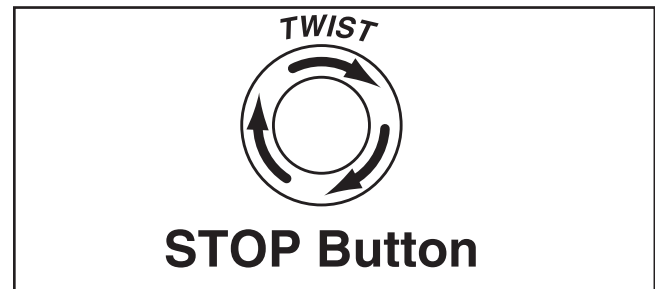

Figure 11. Resetting the switch.

7. Verify that the machine is operating correctly by pushing the ON button.
 - When operating correctly, the machine runs smoothly with little or no vibration or rubbing noises.
 - Investigate and correct strange or unusual noises or vibrations before operating the machine further. Always disconnect the machine from power when investigating or correcting potential problems.
8. With the machine still running, use the speed dial to decrease/increase the spindle speed.
9. Press the stop button to stop the machine.
10. WITHOUT resetting the switch, press the ON button. The machine should not start.
 - If the machine does not start, the stop button safety feature is working correctly. The Test Run is complete.
 - If the machine does start (with the stop button pushed in), immediately disconnect power to the machine. The stop button safety feature is not working correctly. This safety feature must work properly before proceeding with regular operations. Call Tech Support for help.

When all of the **Test Run** procedures are successfully completed, proceed to **Spindle Break-In**.

Spindle Break-In

It is essential to closely follow the proper break-in procedures to ensure trouble-free performance of your mill.

NOTICE

DO NOT leave the area while the break-in procedure is under way. You must be ready to stop the machine if any problem occurs.

NOTICE

Successfully complete the spindle break-in procedure to avoid rapid wear of spindle components when placed into operation.

To perform the spindle break-in procedure:

1. Turn the machine **ON**, then use the speed dial to adjust the spindle speed to approximately 200 RPM.
2. Let the mill run at this speed for 20 minutes, then turn the spindle **OFF** and wait for it to stop.
3. Use the spindle direction switch on the control panel to reverse the spindle direction, then turn the mill **ON** and let it run for another 20 minutes.
4. Set the spindle speed at approximately 1800 RPM, repeat **Steps 2–3**, then proceed to **Step 5**.
5. Turn the mill **OFF**. The spindle break-in is now complete and the machine is ready for operation.



SECTION 4: OPERATIONS

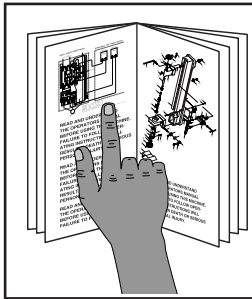

⚠️ WARNING

To reduce the risk of serious injury when using this machine, read and understand this entire manual before beginning any operations.

⚠️ WARNING

Damage to your eyes or face could result from using this machine without proper protective gear. Always wear safety glasses or a face shield when operating this machine.

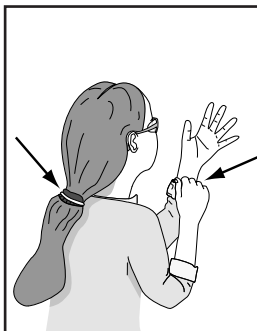
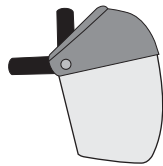

⚠️ WARNING

Loose hair, clothing, or jewelry could get caught in machinery and cause serious personal injury. Keep these items away from moving parts at all times to reduce this risk.

NOTICE

If you have never used this type of machine or equipment before, WE STRONGLY RECOMMEND that you read books, review industry trade magazines, or get formal training before beginning any projects. Regardless of the content in this section, Grizzly Industrial will not be held liable for accidents caused by lack of training.

Basic Controls

Refer to **Figure 12** and the following descriptions to understand the basic controls of your mill.

Control Panel

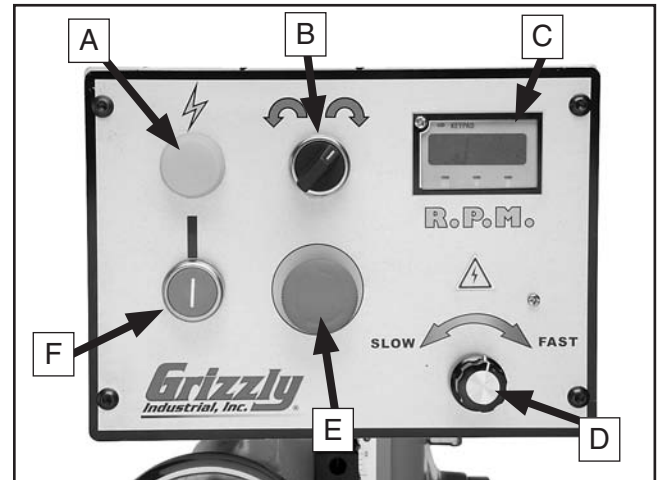

Figure 12. Control panel.

- A. Power Lamp:** Lights when there is power to the machine.
 - B. Direction Switch:** Controls the direction of spindle rotation.
 - C. Digital Speed Readout:** Displays the spindle speed in revolutions per minute (RPM).
 - D. Speed Dial:** Controls the spindle speed.
 - E. Stop Button:** Turns the spindle **OFF**. You must twist this button clockwise so that it pops out before restarting the spindle with the ON button.
- Note:** *Pressing this button DOES NOT DISCONNECT MILL FROM POWER.*
- F. ON Button:** Turns the spindle **ON** when there is power to the machine and the stop button is not pushed in.



Table Controls

Refer to **Figures 13–14** and the following descriptions to understand the functions that affect X-, Y-, and Z-axis table movement.

- A. X-Axis Handwheels:** Controls left-right (X-axis) travel of the table.
- B. X-Axis Limit Stops:** Limits X-axis table travel.
- C. X-Axis Table Locks:** Locks the table, preventing table travel in the X-axis.
- D. Limit Block:** Stops X-axis table movement when the limit stops contact the block.
- E. Y-Axis Handwheel:** Controls in-out (Y-axis) travel of the table.

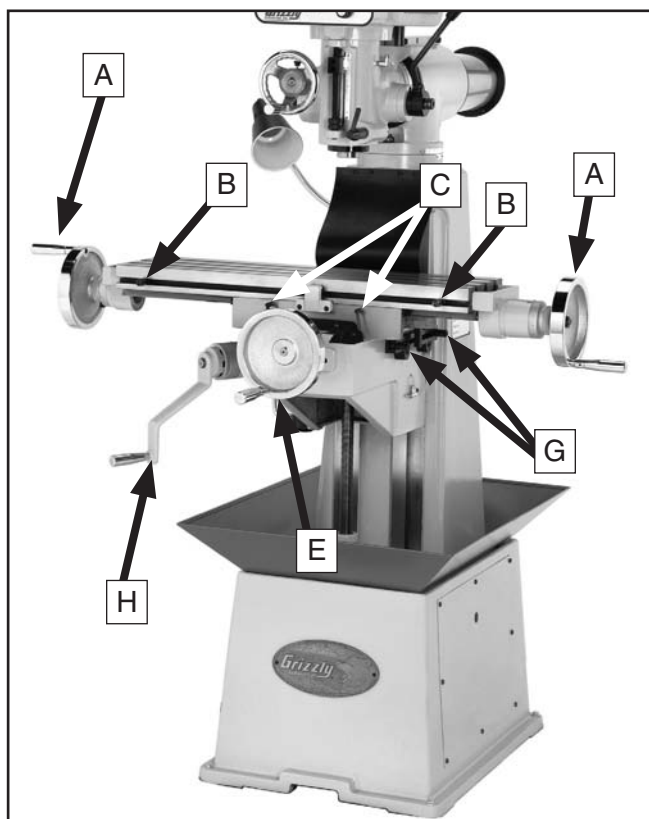

Figure 13. Main table travel controls.

- F. Y-Axis Lock:** Locks the saddle, preventing the table from moving in the Y-axis.
- G. Y-Axis Limit Stops:** Limit Y-axis table travel.
- H. Z-Axis Crank Handle:** Controls up-down (Z-axis) travel of the table.
- I. Z-Axis Lock:** Locks the knee, preventing knee or table travel in the Z-axis.

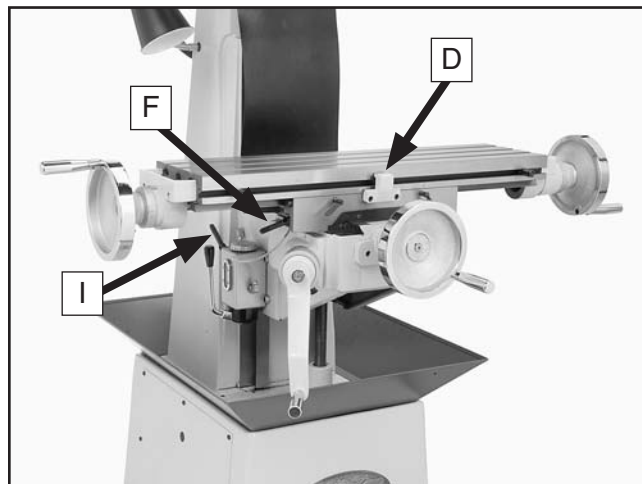

Figure 14. Additional table travel controls.

Downfeed Controls

Refer to **Figures 15–16** and the following descriptions to understand the functions of the downfeed controls that affect the travel of the quill, spindle, and cutter.

- A. Quill Dog:** Moves with the quill. Use the pointer on the side of the dog with the downfeed scale to determine the depth of downfeed.
- B. Downfeed Scale:** Displays in $\frac{1}{8}$ " increments the amount of quill travel.
- C. Coarse Downfeed Handle:** When this handle is enabled with the downfeed selector, it raises/lowers the quill quickly.
- D. Quill Lock:** Locks the quill in place but does not affect spindle rotation.
- E. Downfeed Stop & Lock:** Stops downfeed travel when the quill dog reaches this point. Set the stop at any position along the downfeed scale, then secure it in place by tightening the lock up to it.
- F. Graduated Scale:** Displays quill travel in 0.001" increments when the fine downfeed handwheel is used. One full revolution of the handwheel represents 0.080" of quill travel.
- G. Fine Downfeed Handwheel:** When this handwheel is rotated with the downfeed selector, it raises/lowers the quill in small increments.
- H. Downfeed Selector:** When rotated, enables either coarse or fine downfeed control. Tighten the selector to engage the fine downfeed handwheel, and loosen it to engage the coarse downfeed handle.

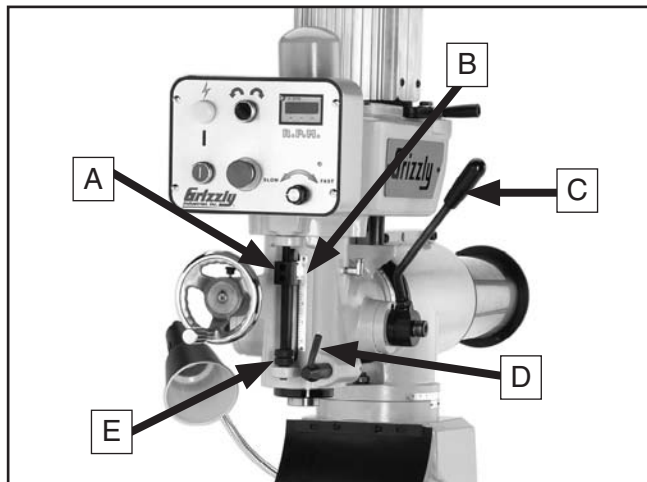

Figure 15. Downfeed controls viewed from the right side.

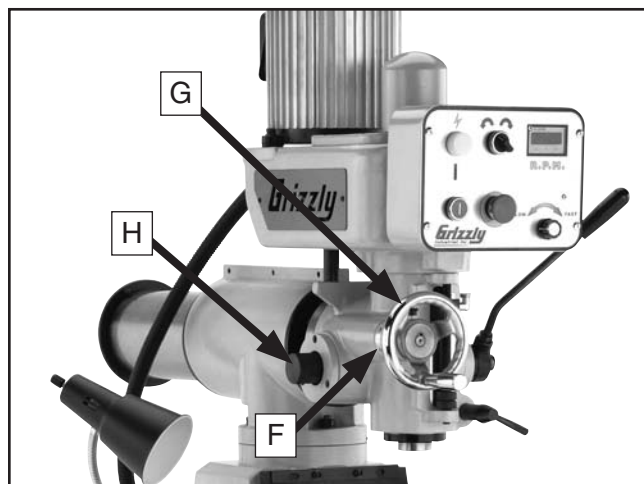

Figure 16. Downfeed controls viewed from the left side.

Operation Overview

This overview gives you the basic process that happens during an operation with this mill. Familiarize yourself with this process to better understand the remaining parts of the **Operation** section.

To complete a typical operation, the operator does the following:

1. Loosens the knee lock, and adjusts the table height to ensure there is sufficient room to install the tooling in the quill and the workpiece on the table.
2. Installs correct tooling for the task.
3. Mounts the workpiece securely to the table using a vise or clamps.
4. Selects the appropriate spindle speed for the workpiece and tooling.
5. Selects the direction the spindle will turn, based on the type of cut needed, using the direction switch.
6. Unlocks the X- and Y-axis table locks, then secures the Z-axis lock.
7. Wears safety glasses or a face shield.
8. Starts the machine.
9. Adjusts the spindle height.
10. For milling operations, uses the X-axis handwheel to move the table left-and-right and uses the Y-axis handwheel to move the table in-or-out, so the cutter removes material evenly from the workpiece.

For drilling operations, uses the coarse downfeed lever or fine downfeed handle to lower the tooling into the workpiece, then raises the tooling out of the workpiece.
11. Presses the STOP button to stop the spindle.

Table Movement

This mill table has three paths of movement controlled by the corresponding handwheels or crank (see **Figure 17**):

1. Left–right (X-axis)
2. In–out (Y-axis)
3. Up–down (Z-axis)

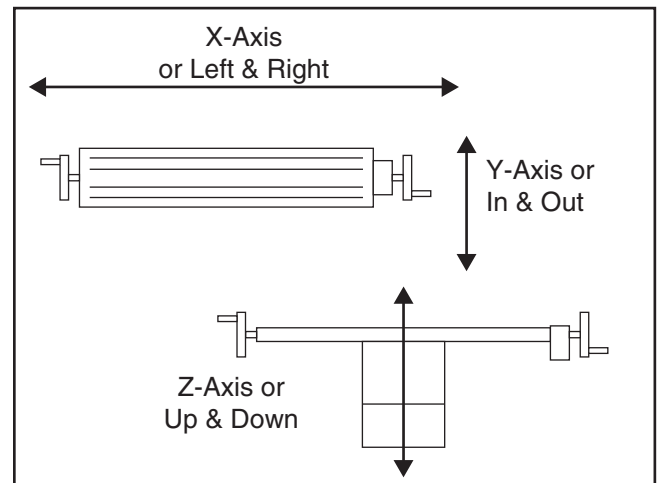

Figure 17. The three movement paths of the mill table.

The graduated dials are marked in increments of 0.001", with a full revolution of the handwheel moving the table 0.125".

Locks

Use the table, saddle, and knee locks shown in **Figures 18–19** to secure the table in position.

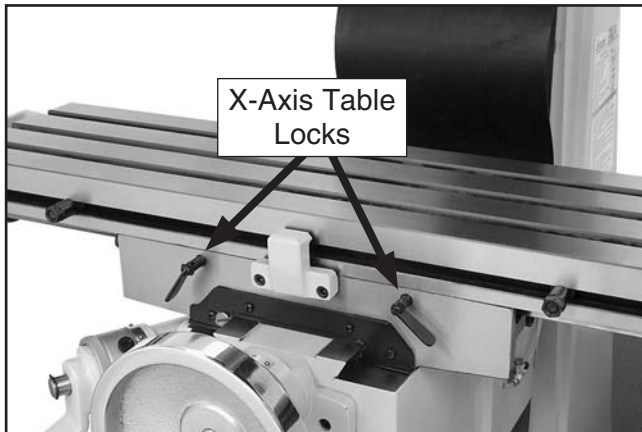

Figure 18. X-axis table locks.

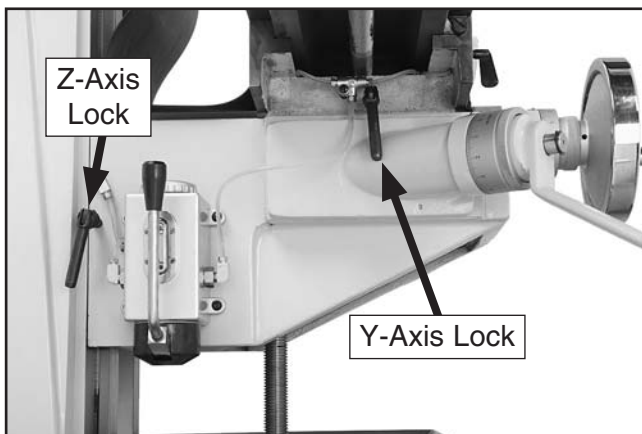

Figure 19. Y-axis and Z-axis locks.

Limit Stops

Position the limit stops along the limit stop tracks to confine the distance the table or saddle can travel (see **Figures 20–21**).

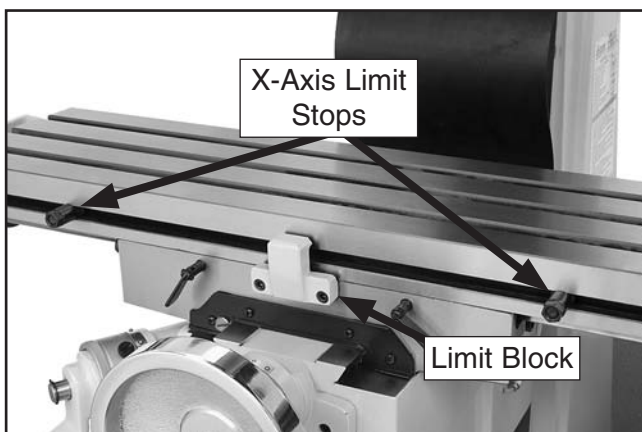

Figure 20. X-axis limit stops and block.

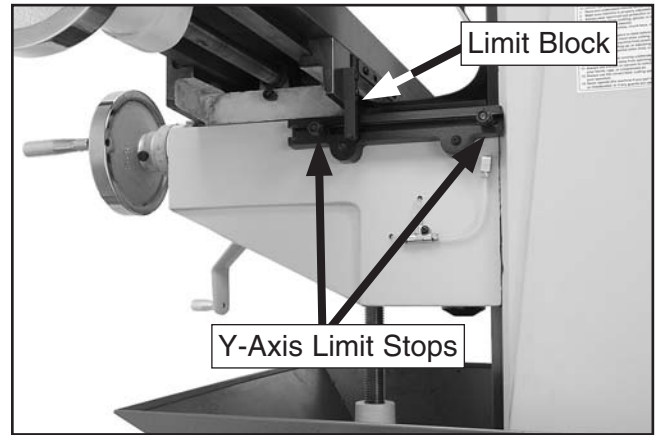

Figure 21. Y-axis limit stops and block.

⚠ CAUTION

Always keep the table locked in place unless controlled movement is required for your operation. Unexpected table movement during operations could cause the cutter to bind with the workpiece resulting in damage to the cutter and workpiece, and possible personal injury.

Headstock Tilting

The head tilts from 45° right to 45° left (see **Figure 22**). However, the headstock can be tilted past 45°R or 45°. If this is done, you will not be able to use the angle scale, and the headstock lock bolts may bind.

NOTICE

This mill is designed to operate with a right-left headstock tilt of 45°. To prevent headstock binding and insufficient support, do not tilt the headstock to a full 90°. Binding occurs when one of the hex bolts on the side of the headstock (Figures 23–24) binds in the T-slot.

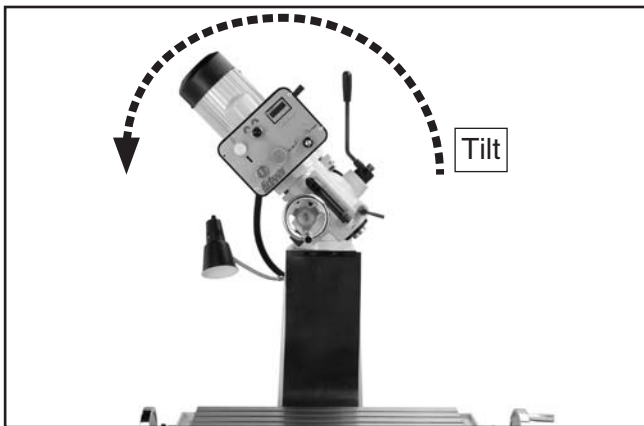

Figure 22. Head tilted 45° to the left.

Tools Needed	Qty
Wrench 19mm	1

To tilt the head:

1. DISCONNECT MILL FROM POWER!
2. Loosen the two locking hex nuts on both sides of the turret (see **Figures 23–24**).

⚠ WARNING

Hold the motor housing when tilting. Do not hold the drawbar cap. If you do, the cap can come off and the headstock can swing down uncontrollably, causing severe personal injury or machine damage.

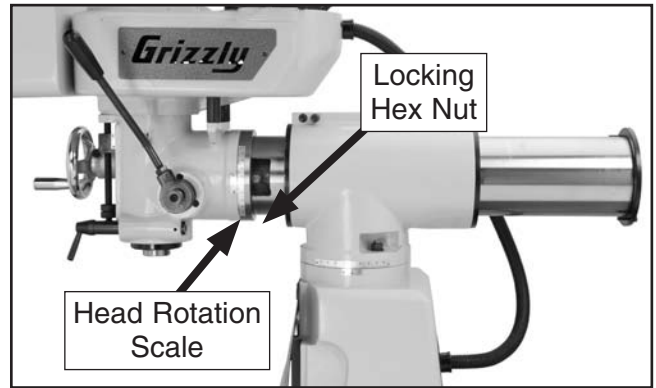

Figure 23. Right side head tilt.

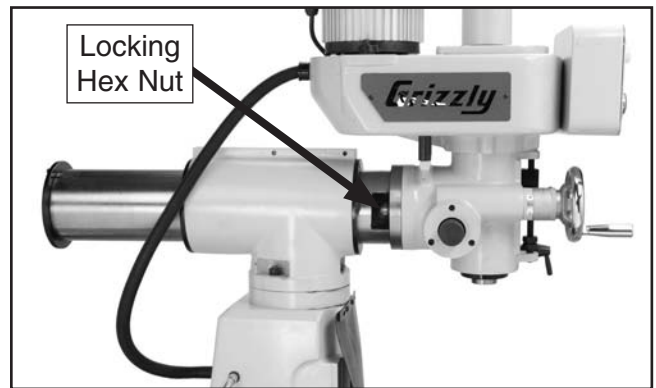

Figure 24. Left side head tilt.

3. While holding the motor, tilt the head up to 45° right or 45° left and use the tilt scale to determine the angle of tilt.
 - If the headstock binds after you tilt it, follow **Steps 5-9** to return the headstock to its vertical position.
4. Re-tighten the two locking hex nuts to secure the headstock.



⚠ CAUTION

Always get an assistant to help you tilt the headstock or tighten the headstock lock nuts during the following steps. The headstock is very heavy and may be difficult to control once it is tilted past 45°R or 45°L. If you do not pay attention, it can flip over, causing serious personal injury and possible machine damage.

5. Determine which of the two hex bolts that lock the headstock vertically is loose.
6. Tighten the locking hex nut on the opposite side of the headstock to secure it.
7. Remove the hex nut and flat washer from the hex bolt that is loose.
8. While an assistant holds the machine motor, loosen the locking hex nut on the opposite side, then push the loose hex bolt back into the headstock (see **Figure 25**) until your assistant can tilt the headstock back to the vertical position.

Note: *The head of the hex bolt must re-engage with the T-slot on the inside of the headstock for the headstock to move.*

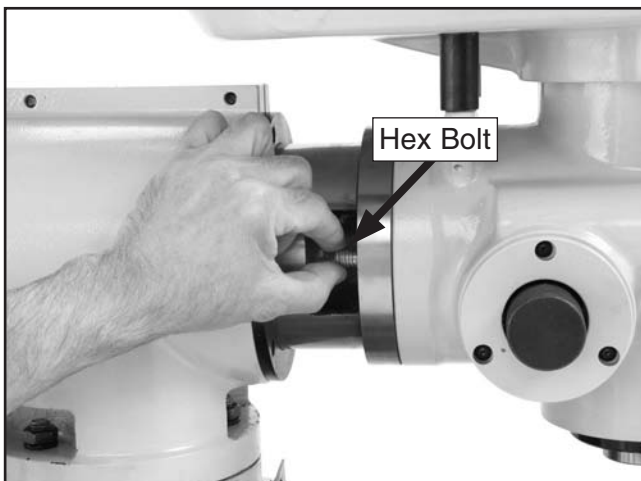

Figure 25. Pushing hex bolt back into headstock.

9. Reinstall the flat washer and hex nut you removed earlier.

⚠ CAUTION

Always lock the head firmly in place after adjusting the tilt. Unexpected movement of the head during operations could cause the cutter to bind with the workpiece causing damage to the cutter and workpiece, and possible personal injury.

Headstock Turret Rotation

The turret rotates 360° around the column (see **Figure 26**).

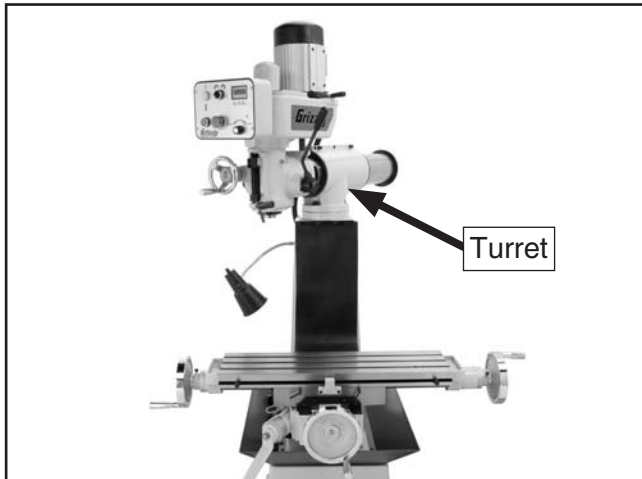

Figure 26. Headstock turret rotated 45° to the left.

Tools Needed	Qty
Wrench 19mm	1

To rotate the turret:

1. DISCONNECT MILL FROM POWER!

CAUTION

Always lock the turret firmly in place after adjusting the rotation. Unexpected movement of the head during operations could cause the cutter to bind with the workpiece causing damage to the cutter and workpiece, and possible personal injury.

2. Loosen the three locking hex nuts on the turret (see **Figure 27**).

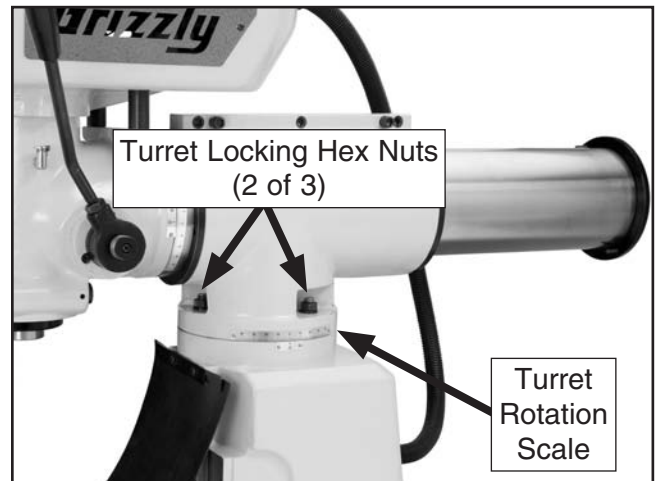

Figure 27. Turret rotation locking hex nuts (2 of 3 shown).

3. Rotate the head and turret around the column to the left or right, and use the turret rotation scale to determine the amount of rotation.

NOTICE

Do not rotate the headstock past 50° right or 50° left. If you do, you run the risk of binding a turret bolt and the headstock could jam.

—If the headstock jams, remove the rear-most turret locking hex nut. While swiveling the exposed hex bolt back and forth, rotate the column until the headstock freely moves, then reinstall the locking hex nut.

Note: Swiveling the hex bolt head allows the flats of the bolt head to re-align with the T-slot.

4. Re-tighten the three locking hex nuts to secure the head and turret in place.



Headstock Ram Movement

The headstock can be moved inward or outward along the ram.

⚠️ WARNING

Always lock the ram firmly in place after adjusting its position. If the headstock slips during milling operation, the spinning cutter could bind and break apart, causing serious personal injury or property damage.

Tools Needed	Qty
Hex Wrench 8mm.....	1

To move the ram inward or outward:

1. DISCONNECT MILL FROM POWER!
2. Loosen the three recessed cap screws, then tighten the two raised cap screws slightly to expand the clamp (see **Figure 28**).

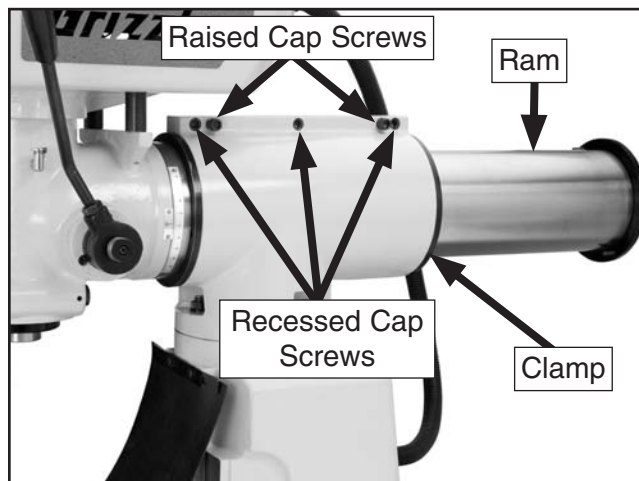

Figure 28. Location of cap screws for adjusting ram movement.

3. Push or pull the headstock in the direction of desired ram movement.
4. Loosen the two raised cap screws to allow the clamp to close, then tighten the three recessed cap screws to tighten the clamp around the headstock tube.



Setting Spindle Speed

To select the correct spindle speed (RPM) for your milling operation, you will need to: 1) Determine the spindle speed needed for your workpiece, and 2) set the speed dial for the calculated speed.

This mill is designed to use most end mills, drill bits, and face cutters that are 3" in diameter or less. The milling table has a coolant system trough with drain for an optional fluid system.

Calculating Spindle Speed

1. Use the table in **Figure 29** to determine the cutting speed or surface feet per minute (SFM) required for your workpiece material.

Cutting Speeds for High Speed Steel (HSS) Cutting Tools	
Workpiece Material	Cutting Speed (SFM)
Aluminum & alloys	300
Brass & Bronze	150
Copper	100
Cast Iron, soft	80
Cast Iron, hard	50
Mild Steel	90
Cast Steel	80
Alloy Steel, hard	40
Tool Steel	50
Stainless Steel	60
Titanium	50
Plastics	300-800
Wood	300-500

Note: For carbide cutting tools, double the cutting speed. These values are a guideline only. Refer to the *MACHINERY'S HANDBOOK* for more detailed information.

Figure 29. Cutting speed table for HSS cutting tools.

2. Measure the diameter of your cutting tool in decimal inches.

3. Use the following formula to calculate the required spindle speed (RPM) for your operation:

$$\frac{\text{Cutting Speed (SFM)} \times 4}{\text{Tool Diameter (in inches)}} = \text{RPM}$$

Setting Spindle Speed

1. Rotate the speed dial all the way to the left, setting the startup spindle speed close to zero.

Note: This precaution avoids unexpected high speed startup of the spindle.

2. Use the direction switch to select the direction of spindle rotation, turn the spindle **ON**, then rotate the speed dial until the calculated spindle speed is displayed at the digital readout on the control panel (see **Figure 30**).

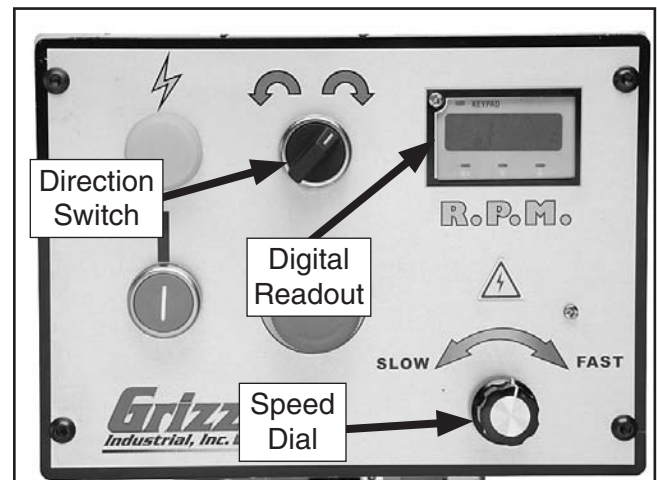

Figure 30. Spindle direction switch, speed dial, and digital readout.

⚠ WARNING

Failure to follow spindle speed and feed rate guidelines may threaten operator safety from ejected parts or ejected tools.

Remember: Milling with the quill fully extended can cause tool chatter. For maximum spindle rigidity, keep the spindle retracted into the headstock as far as possible with the quill lock lever locked and the downfeed selector tightened.



Chip Characteristics

If chips produced by your operation are blue and burnt and overheated, but the cutting speed is correct, reduce the feed rate until the chips are silver.

If the chips are powdery, increase the feed rate so the chips are more coarse but not overheated.

Loading/Unloading Tooling

Your mill is equipped with a 7/16"-20 x 12" drawbar (see **Figure 31**).



Figure 31. Drawbar.

Tools Needed	Qty
Wrench 19mm	1

Loading Tooling

1. DISCONNECT MILL FROM POWER!
2. Clean any debris or oily substances from the mating surfaces of the spindle and tool tapers.

CAUTION

Cutting tools are sharp and can quickly injure your hands. Always protect your hands when handling cutting tools.

3. Remove the drawbar cap and place the drawbar through the top of the spindle if it is not already installed (see **Figure 32**).

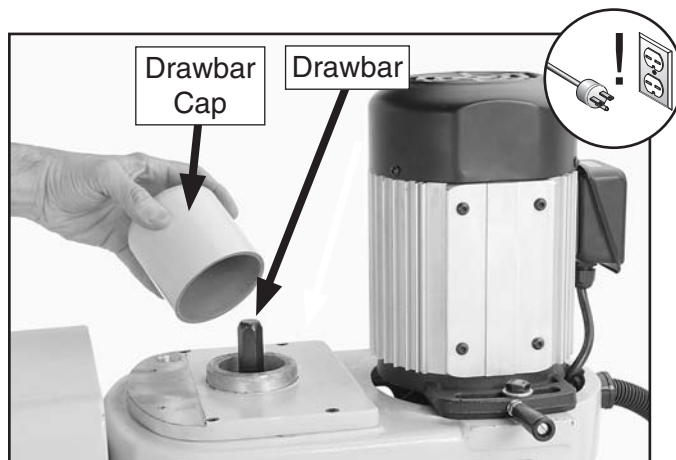

Figure 32. Drawbar inserted through the top of the spindle.

4. Align the keyway of the tool (collet with cutter, face mill, or drill chuck with taper shank) with the protruding set screw inside the spindle, and push the tool firmly into the spindle taper to seat it.
5. While holding the tool in place with one hand, thread the drawbar into the tool until it is snug.

Note: Make sure the drawbar is threaded into the tool a minimum of five to 10 turns.

6. To fully seat the tool into the spindle, tighten the drawbar with a 19mm wrench.

Note: Over-tightening the drawbar could make removing the tool difficult, so only snug the drawbar in place.

7. Re-install the drawbar cap.

Unloading Tooling

1. DISCONNECT MILL FROM POWER!
2. While wearing gloves, keep one hand on the tool, loosen the drawbar with the 19mm wrench, then completely unthread it.

—If the tool does not release from the spindle taper when the drawbar is unthreaded, turn the drawbar back into the tool five to ten threads, then tap the top of the drawbar with a dead-blow hammer or block of wood until the tool releases.

SECTION 5: ACCESSORIES

H6087—2 Axis Digital Readout (8" x 20")

H6091—3 Axis Digital Readout (8" x 20" x 5")

You will be amazed the list of features for these DROs that include: selectable resolution down to 5µm, absolute/incremental coordinate display, arc function, line of holes function, angled cuts function, 199 user defined datum points, centering/cutter offset, double sealed scales, inches/millimeters, calculator with trig functions, and linear error compensation.

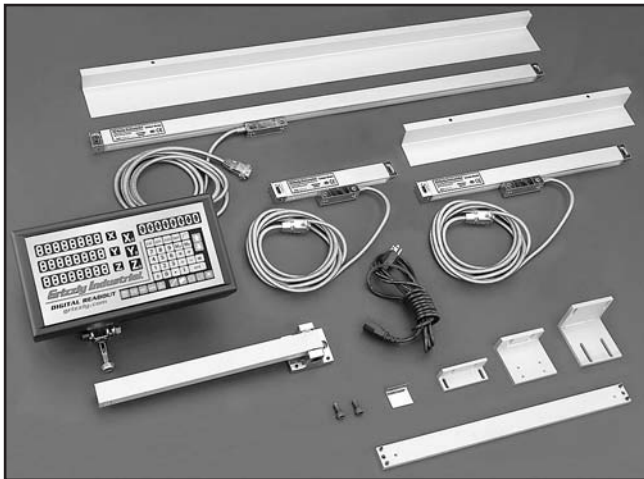

Figure 33. 3 Axis Digital Read Out.

G1075—52-PC. Clamping Kit

This clamping kit includes 24 studs, 6 step block pairs, 6 T-nuts, 6 flange nuts, 4 coupling nuts, and 6 end hold-downs. The rack is slotted so it can be mounted close to the machine for easy access. Made for 1/2" T-slots.

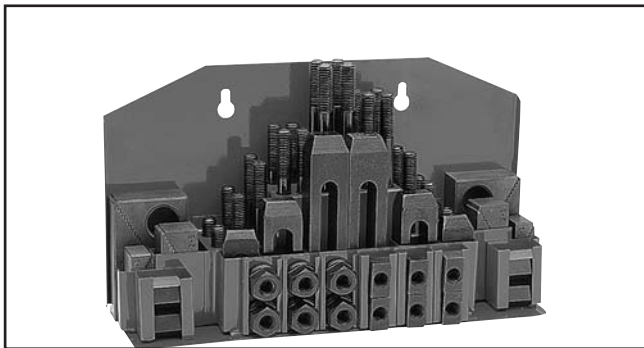

Figure 34. G1075 52-PC. Clamping Kit.

Call 1-800-523-4777 To Order

H8257—Primrose Armor Plate with Moly-D Machine and Way Oil 1 Quart

This superior machine and way lubricant prevents stick slip and chatter due to anti-friction capabilities resulting in greater precision machining capabilities. Provides the thinnest oil film possible while effectively providing needed lubrication and rust/corrosion protection. Adhesive/cohesive components are added for vertical surfaces. Resists squeeze out, running, dripping and non-gumming.



"This is good stuff!
I use it on my lathes
at home."

S. Balolia – President



Figure 35. Primrose Armor Plate Lubricant.

T10063—Milling Vise 12⁵/₁₆" x 6⁹/₁₆"

T10064—Milling Vise 17¹/₈" x 8³/₄"

- Ultra precise in flatness, parallelism and verticality.
- Anti-lift mechanism ensures the workpiece does not lift when jaws are tightened.
- Ductile iron body.
- Flame hardened vise bed and jaws.
- Sealed bearing system.
- 8200 lbs. of clamping pressure.



Figure 36. T10064 Milling vise (handle included, but not shown).

G9299—10" Yuasa-Type Rotary Table

This high precision rotary table features extra deep coolant channels, dual positive action locks, very low profiles, 10 second vernier scales, gear drives with oil immersion and satin chrome dials. See the current Grizzly catalog for full specifications. Features: 4.330" overall height (horizontal), 6.750" height to center hole (vertical), #3 Morse Taper, 0.465" T-slot width, and 117 lb approximate shipping weight.

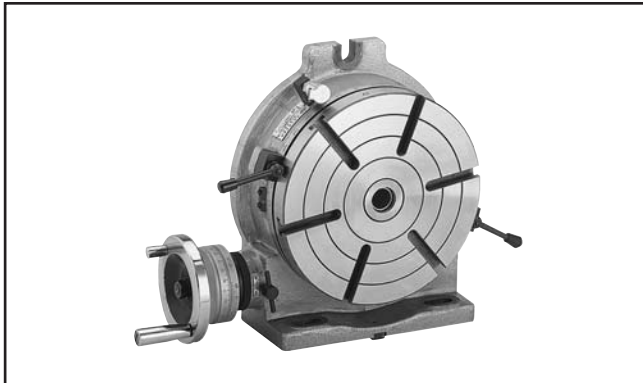

Figure 37. G9299 10" Yuasa-Type Rotary Table.

T20501—Face Shield Crown Protector 4"

T20502—Face Shield Crown Protector 7"

T20503—Face Shield Window

T20452—"Kirova" Anti-Reflective S. Glasses

T20451—"Kirova" Clear Safety Glasses

H0736—Shop Fox® Safety Glasses

H7194—Bifocal Safety Glasses 1.5

H7195—Bifocal Safety Glasses 2.0

H7196—Bifocal Safety Glasses 2.5



Figure 38. Eye protection assortment.

G5562—SLIPIT® 1 Qt. Gel

G5563—SLIPIT® 12 oz Spray

G2871—Boeshield® T-9 12 oz Spray

G2870—Boeshield® T-9 4 oz Spray

H3788—G96® Gun Treatment 12 oz Spray

H3789—G96® Gun Treatment 4.5 oz Spray



Figure 39. Recommended products for protecting unpainted cast iron/steel part on machinery.

H8370—Power Feed for Mills

If you want to get the most out of your mill, you really need a power feed. This power feed comes with everything required to start milling with exact control. Comes supplied with a mounting bracket, gear, auto-stop limit switch with moveable stop pins, gear guard, and motor. Specs: 0–140 RPM, 200 RPM rapid switch, 440 in/lb. maximum torque, 110V 60Hz motor, 4:1 bevel drive gear.



Figure 40. H8370 power feed.

Call 1-800-523-4777 To Order



H2689—R-8 Quick Change Collet Set

An affordable quick change collet system with ultra precision. These spring collets are hardened and ground to exacting tolerances and offer incredible holding power. This set includes an R-8 arbor and nut, spanner wrench, plastic carrying case and collets sized $\frac{1}{8}$ ", $\frac{1}{4}$ ", $\frac{3}{8}$ ", $\frac{1}{2}$ ", $\frac{5}{8}$ ", $\frac{3}{4}$ ", $\frac{7}{8}$ ", and 1". What's more, the nut features a self-ejecting rim! A set like this will truly speed up any tool changing process. Drawbar size is $\frac{7}{16}$ " x 20.

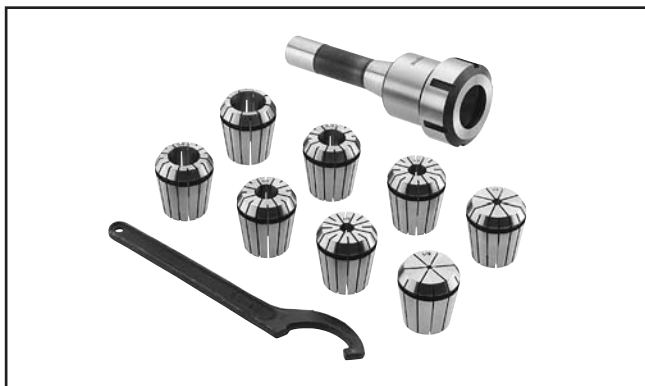

Figure 41. H2689 R-8 Quick Change Collet Set.

G5641—1-2-3 Blocks

G9815—Parallel Set

H5556—Edge Finder Set

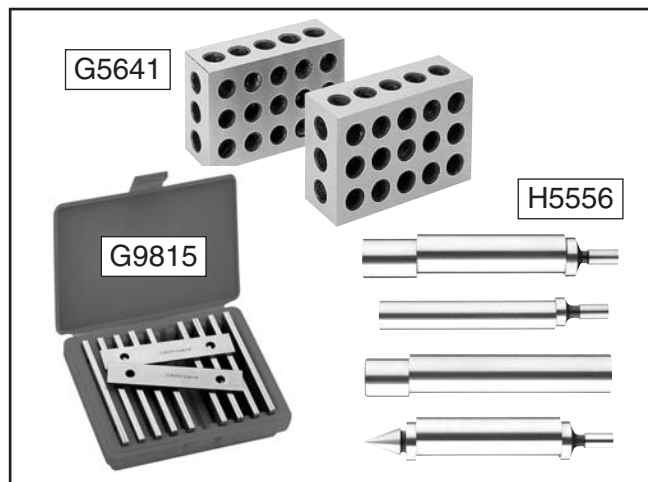

Figure 42. G5641 1-2-3 Blocks, G9815 Parallel Set, and H5556 Edge Finder Set.

G2861—Face Mill

G4051—Carbide Insert for Face Mill

This 2 $\frac{1}{2}$ " Face Mill accepts four carbide inserts (not included). Comes with an R-8 arbor.



Figure 43. G2861 Face Mill.

G9760—20-PC. 2 & 4 Flute TiN End Mill Set.

Includes these sizes and styles in two and four flute styles: $\frac{3}{16}$ ", $\frac{1}{4}$ ", $\frac{5}{16}$ ", $\frac{3}{8}$ ", $\frac{7}{16}$ ", $\frac{1}{2}$ ", $\frac{9}{16}$ ", $\frac{5}{8}$ ", $\frac{3}{8}$ ", $\frac{11}{16}$ ", and $\frac{3}{4}$ ".



Figure 44. G9760 20-PC End Mill Set.

G9765—9-PC. Ball End Mill Set

Features 2 flute ball nose end mills. Includes the following sizes: $\frac{1}{8}$ ", $\frac{3}{16}$ ", $\frac{1}{4}$ ", $\frac{5}{16}$ ", $\frac{3}{8}$ ", $\frac{7}{16}$ ", $\frac{1}{2}$ ", $\frac{5}{8}$ " and $\frac{3}{4}$ ".

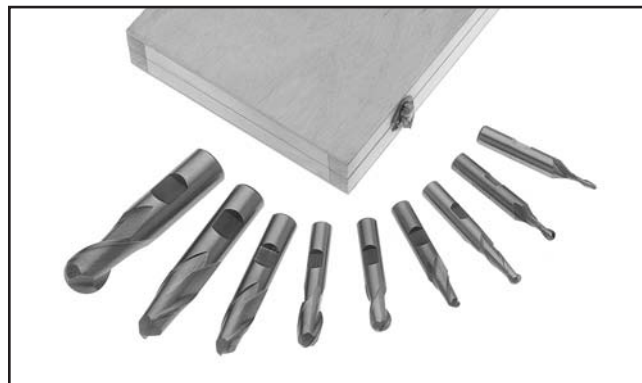

Figure 45. G9765 9-PC. Ball End Mill Set.

G5758—Tilt Table 5" x 7"

Set your work at any angle with these sturdy tilt tables. Heavy-duty construction includes T-slots, two locking screws and precision base that allows the table to tilt from -45 Degrees to +45 Degrees. Table size: 5" x 7".

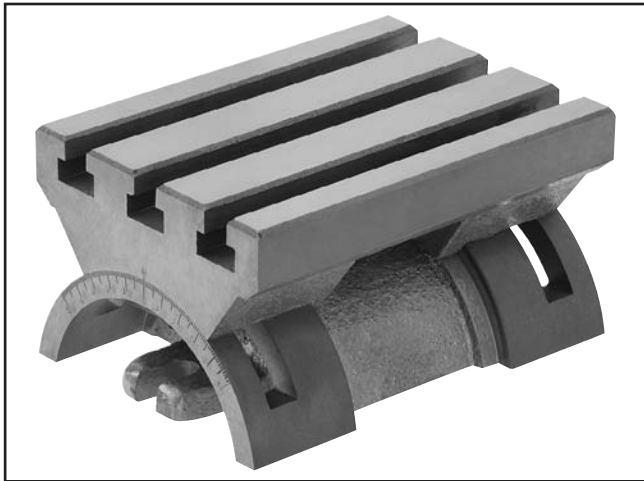

Figure 46. Model G5758 Tilt Table.

G5684—R-8 Vertical Collet Rack"

No more loose R-8 collets laying around in your tool box. Organize with this handy collet rack and you won't be looking at each one for the correct size. Set on your bench or mount to a wall. Holds 48 collets.



Figure 47. Model G5684 Tilt Table.

G5649—5-C Spin Index

Fitted with a traveling spindle and collar, the 5-C Spin Index is unmatched for forming, grinding, and inspecting end mills and other fluted cutting tools. This spin index accepts 5-C collets up to 1/8" capacity and features a 36 hole indexing plate with 10 vernier holes for indexing to 1 degree. Locking spindle is hardened and ground and has 2 1/16" of travel.

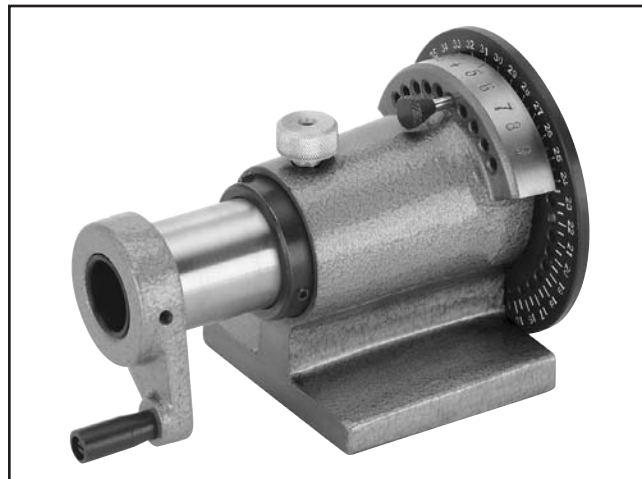

Figure 48. Model G5649 5-C Spin Index.

G1054—Dividing Head-BS-1

These high quality dividing heads are made with demanding care for precision gear-cutting, sharpening milling cutters, reamers, etc. Dividing heads come complete with 3 dividing plates, 1 tailstock, 1 chuck back plate, 1 center-dog and 1 center. Thread on nose 1 1/2" x 8 TPI. Ratio: 40:1

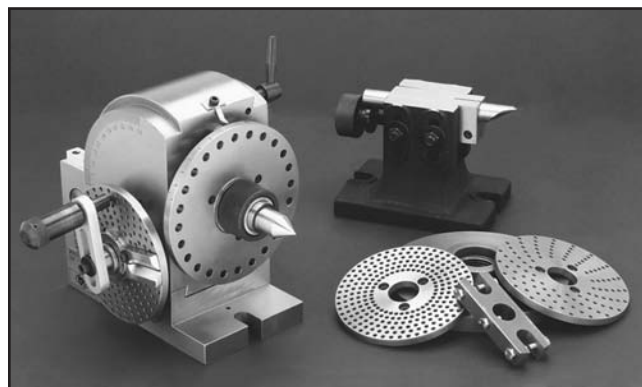

Figure 49. Model G1054 Dividing Head - BS-1.

G5679—Steel Parallel Set

These ground and hardened sets feature four pairs of 6" long parallels that are accurate to within 0.0003" in parallelism and 0.0002" in height. Comes in a wooden case. Type: ½".

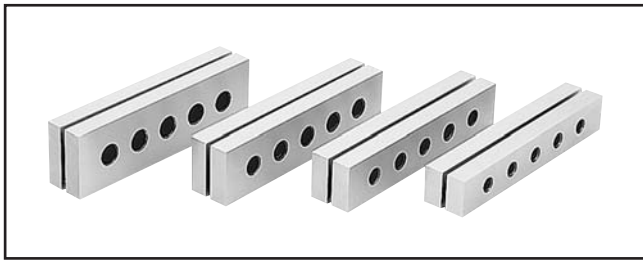

Figure 50. Model G5679 Steel Parallel Set.

G9029—R-8 Shell End Mill Arbor ½"

G9030—R-8 Shell End Mill Arbor ¾"

G9031—R-8 Shell End Mill Arbor 1"

G9032—R-8 Shell End Mill Arbor 1¼"

G9033—R-8 Shell End Mill Arbor 1½"

G9034—R-8 Shell End Mill Arbor 5-Pc Set

These Shell End Mills are just the ticket for those large jobs. Whether you're facing slotting, edging, or shouldering, you'll agree these beauties have outstanding performance! Priced less than half the cost of similar sized end mills with shanks, you can't afford not to buy these!



Figure 51. Model G9029–G9034 Shell End Mill Arbors.

G9015—R-8 Shell End Mill 4½" x 4½" x 1½"

G9016—R-8 Shell End Mill 5" x 2¼" x 1½"

These Shell End Mills are just the ticket for those large jobs. Whether you're facing slotting, edging, or shouldering, you'll agree these beauties have outstanding performance! Priced less than half the cost of similar sized end mills with shanks, you can't afford not to buy these!



Figure 52. Model G9015–G9016 Shell End Mills.

G9582—V-Angle Plane 3" x 3" x 5"

G9583—V-Angle Plane 4" x 4" x 6"

G9584—V-Angle Plane 5" x 5" x 7"

G9585—V-Angle Plane 6" x 6" x 8"

These V-Angle Plates are manufactured from high grade cast iron that is fully stress relieved to give stability throughout their working life. The V-Angles have many more clamping positions than ordinary angle plates and allow almost any shape to be clamped securely with many types of clamps. Priced per piece.

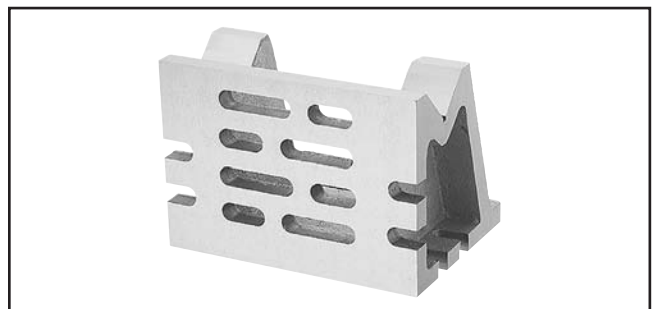

Figure 53. Model G9582–G9585 V-Angle Plates.



SECTION 6: MAINTENANCE



Schedule

For optimum performance from your machine, follow this maintenance schedule and refer to any specific instructions given in this section.

Before Daily Operation:

- Check/tighten loose mounting bolts.
- Check/sharpen/replace worn or damaged tooling.
- Check/repair/replace worn or damaged wires.
- Check for any other unsafe condition.
- Use the one-shot oiler (**Page 36**).

Every 8 Hours of Operation:

- Use the one-shot oiler (**Page 36**).
- Lubricate quill gearing (**Page 36**).
- Clean the mill.

Every 40 Hours of Operation:

- Lubricate the vertical bevel gears (**Page 36**).
- Lubricate the longitudinal, cross, and vertical leadscrews (**Page 37**).

Note: *This maintenance schedule is based on average usage. Adjust the maintenance schedule to match your actual usage to keep your mill running smoothly and to protect your investment.*

Cleaning & Protecting

Use a brush and shop vacuum to remove chips and debris from the mill. Never blow off the mill with compressed air, as this will force metal chips deep into the mechanisms and may injure yourself or bystanders.

Wipe built-up grime from the mill with a rag and a mild solvent. Remove any rust from the unpainted cast iron surfaces of your mill, then treat them with regular applications of products such as Primrose Armor Plate Way Oil, G96® Gun Treatment, SLIPIT®, or Boeshield® T-9 (see **Section 5: Accessories** on **Page 30** for more details).

Lubrication

Your mill has numerous moving metal-to-metal contacts that require proper lubrication to help ensure efficient and long-lasting mill operation.

Other than the lubrication points covered in this section, all other bearings are internally lubricated and sealed at the factory. Simply leave them alone unless they need to be replaced.

Before adding lubricant, clean debris and grime from the devices to avoid contaminating the new lubrication.

DISCONNECT MILL FROM POWER BEFORE PERFORMING LUBRICATION!



NOTICE

Failure to follow the lubrication practices outlined in this manual could lead to premature failure of your mill and void the warranty.

One-Shot Oiler

Lubricant	Frequency	Qty
ISO 68 Lubricant or Equivalent	Every 8 Hours of Operation	1 Pump

The oil lines running from the one-shot oiler feed lubrication to the ways of the column (knee), saddle, and table.

Use the sight glass on the front of the oiler to make sure it is full, then pull the handle (see **Figure 54**) and release it to send lubricant through the lines.

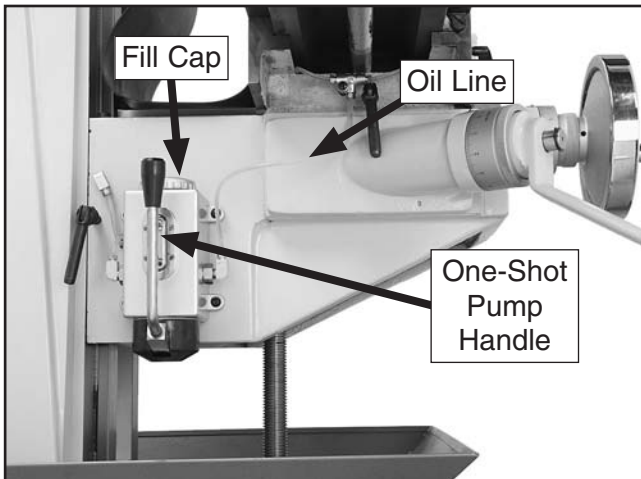

Figure 54. One-shot oiler.

Quill Gearing

Lubricant	Frequency	Qty
ISO 68 Lubricant or Equivalent	Every 8 Hours of Operation	5 Drops

Lift the cap of the oil cup shown in **Figure 55** to add the lubricant.



Figure 55. Quill gearing oil cup.

Vertical Bevel Gears

Lubricant	Frequency	Qty
NLGI #2 Grease	Every 40 Hours of Operation	Thin Coat

Raise the knee up to access the vertical bevel gears underneath the saddle, then clean and lubricate the bevel gears shown in **Figure 56**.

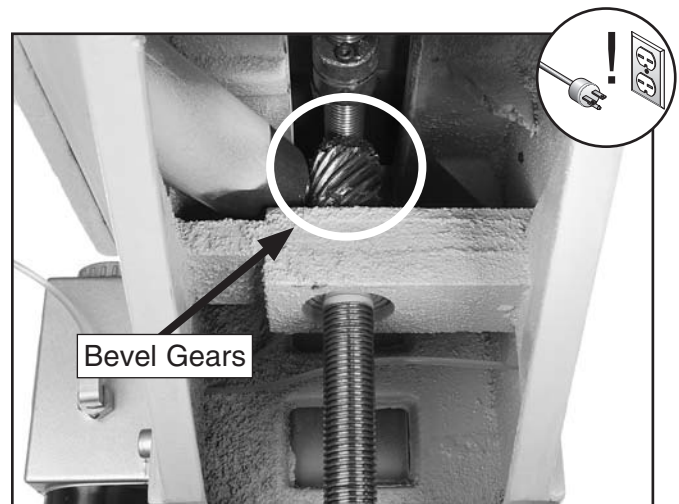

Figure 56. Vertical bevel gears.



Leadscrews

Lubricant	Frequency	Qty
NLGI #2 Grease	Every 40 Hours of Operation	Thin Coat

Use a shop rag and mineral spirits to clean away debris and grime from the longitudinal, cross, and elevation leadscrews and leadscrew nuts. Apply a thin coat of lubricant to the leadscrews, then move the table through the full range of movement for each leadscrew to distribute the grease (see **Figures 57–58**).



Figure 57. Longitudinal leadscrew.

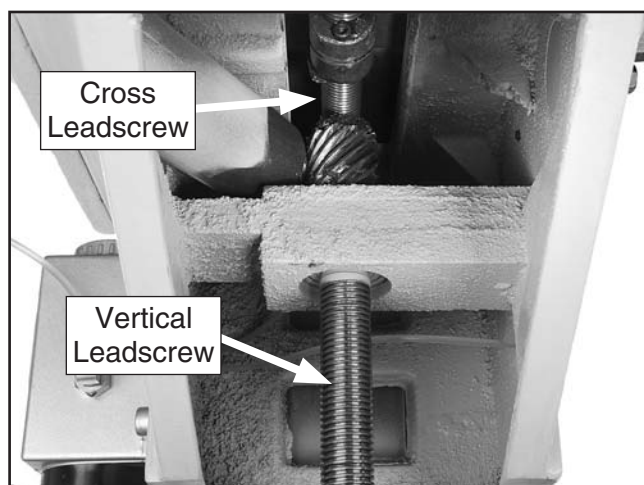

Figure 58. Cross and vertical leadscrews.

V-Belt Tensioning

Periodically remove the belt cover and inspect the belt for cracking, slipping, or fraying. If the belt shows signs of excessive wear, replace it as outlined in **Belt Replacement on Page 41**.

However, with normal use, the belt will gradually stretch over time. When it does, perform the following procedures to keep it tensioned. No belt deflection is recommended for this belt.

Tools Needed	Qty
Wrench 17mm.....	1

To tension the V-belt:

1. DISCONNECT MILL FROM POWER!
2. Using a 17mm wrench, loosen the lock bolt, push firmly and hold the belt tension lever toward the rear of the machine and retighten the lock bolt (**Figure 59**).

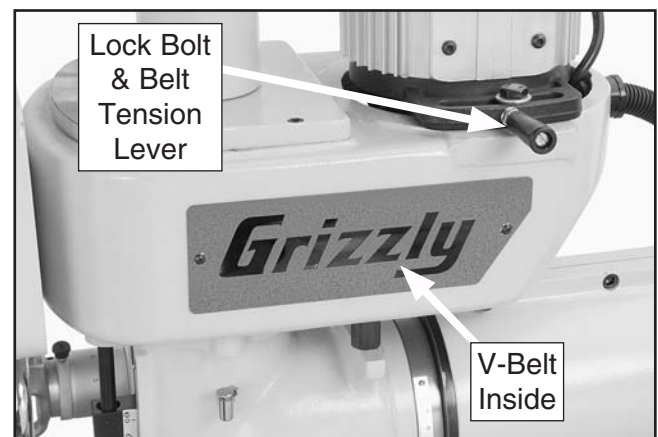

Figure 59. V-belt tension adjustment bolt.



SECTION 7: SERVICE

Review the troubleshooting and procedures in this section to fix or adjust your machine if a problem develops. If you need replacement parts or you are unsure of your repair skills, then feel free to call our Technical Support at (570) 546-9663.

Troubleshooting



Motor & Electrical

Symptom	Possible Cause	Possible Solution
Machine does not start or a breaker trips.	<ol style="list-style-type: none"> 1. Stop button is pushed in or is at fault. 2. ON button is at fault. 3. Plug/receptacle is at fault or wired incorrectly. 4. Power supply is switched OFF or is at fault, or the breaker tripped. 5. Motor connection wired incorrectly. 6. Motor windings or motor is at fault. 	<ol style="list-style-type: none"> 1. Turn the stop button clockwise until it pops out; replace if faulty. 2. Replace faulty ON button. 3. Test for good contacts; correct the wiring. 4. Ensure hot lines have correct voltage on all legs and main power supply is switched ON. 5. Correct motor wiring connections (Page 44). 6. Replace motor.
Machine stalls or is overloaded.	<ol style="list-style-type: none"> 1. Machine is undersized for the task. 2. Workpiece alignment is poor. 3. Dull or incorrect cutting tool. 4. Motor connection is wired incorrectly. 5. Plug/receptacle is at fault. 6. Pulley/sprocket slipping on shaft. 7. Motor bearings are at fault. 8. Motor has overheated. 9. Motor is at fault. 	<ol style="list-style-type: none"> 1. Use smaller sharp tooling; reduce the feed rate; reduce the spindle RPM; use coolant. 2. Eliminate workpiece binding; use vise or clamps as required for workpiece alignment control. 3. Use sharp and correct cutting tool for the operation. 4. Correct motor wiring connections (Page 44). 5. Test for good contacts; correct the wiring. 6. Replace loose pulley/shaft. 7. Test by rotating shaft; rotational grinding/loose shaft requires bearing replacement. 8. Clean off motor, let cool, and reduce workload. 9. Test and repair or replace.
Machine has vibration or noisy operation.	<ol style="list-style-type: none"> 1. Tool holder or cutter is at fault. 2. Workpiece alignment is poor. 3. Motor or component is loose. 4. Pulley is loose. 5. Machine is incorrectly mounted or sits unevenly. 6. Motor fan is rubbing on fan cover. 7. Motor bearings are at fault. 	<ol style="list-style-type: none"> 1. Replace out-of-round tool holder; replace/resharpen cutter; use appropriate feed rate and cutting RPM. 2. Eliminate workpiece binding; use vise or clamps as required for workpiece alignment control. 3. Inspect/replace stripped or damaged bolts/nuts, and re-tighten with thread locking fluid. 4. Realign/replace shaft, pulley, setscrew, and key as required. 5. Tighten/replace mounting bolts in floor; relocate/shim machine. 6. Replace dented fan cover or fan. 7. Test by rotating shaft; rotational grinding/loose shaft requires bearing replacement.



Operation

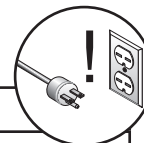

Symptom	Possible Cause	Possible Solution
Tool slips in collet.	<ol style="list-style-type: none"> 1. Collet is not fully drawn into spindle taper. 2. Wrong size collet. 3. Debris on collet or spindle mating surface. 4. Excessive depth of cut. 	<ol style="list-style-type: none"> 1. Snug up drawbar. 2. Use correct collet for shank diameter. 3. Remove oil and debris from collet and spindle mating surfaces, then re-install. 4. Decrease depth of cut and allow chips to clear.
Breaking tooling.	<ol style="list-style-type: none"> 1. Spindle speed/feed rate too fast. 2. Tooling getting too hot. 3. Excessive depth of cut. 	<ol style="list-style-type: none"> 1. Use correct spindle RPM and feed rate (Page 28). 2. Use coolant; reduce spindle RPM/feed rate. 3. Decrease depth of cut and allow chips to clear.
Machine is loud when cutting; overheats or bogs down in the cut.	<ol style="list-style-type: none"> 1. Excessive depth of cut. 2. Dull tooling. 3. Feed rate too fast. 	<ol style="list-style-type: none"> 1. Decrease depth of cut and allow chips to clear. 2. Use sharp tooling. 3. Decrease feed rate.
Workpiece vibrates or chatters during operation.	<ol style="list-style-type: none"> 1. Locks not tight. 2. Workpiece not securely clamped to table or mill vise. 3. Tooling not secure or is damaged. 4. Spindle speed/feed rate too fast. 5. Gibs are too loose. 	<ol style="list-style-type: none"> 1. Tighten all locks on mill that are not associated with movement for the operation. 2. Check that clamping is tight and sufficient for the operation; make sure mill vise is tight to table. 3. Secure tooling; replace if damaged. 4. Use correct spindle RPM and feed rate (Page 28). 5. Adjust gibs properly (Page 40).
Table hard to move.	<ol style="list-style-type: none"> 1. Locks are tightened down. 2. Chips have loaded up on the ways. 3. Ways are dry and in need of lubrication. 4. Gibs are too tight. 	<ol style="list-style-type: none"> 1. Fully loosen locks needed for movement. 2. Frequently clean away chips that load up during operations. 3. Use one-shot oiler to lubricate ways (Page 36). 4. Adjust gibs properly (Page 40).
Bad surface finish.	<ol style="list-style-type: none"> 1. Wrong spindle speed/feed rate. 2. Dull/damaged tooling; wrong tooling for operation. 3. Wrong spindle rotation for tooling. 4. Workpiece not securely clamped to table or mill vise. 5. Gibs are too loose. 	<ol style="list-style-type: none"> 1. Use correct spindle RPM and feed rate (Page 28). 2. Sharpen/replace tooling; use correct tooling for operation. 3. Check for proper spindle rotation for tooling. 4. Check that clamping is tight and sufficient for the operation; make sure mill vise is tight to table. 5. Adjust gibs properly (Page 40).



Adjusting Gibs

Gibs control the accuracy of the table movements along the ways. Tight gibs make the movements more accurate, but harder to move. Loose gibs make the movements sloppy, but easier to move. The goal of gib adjustment is to remove unnecessary sloppiness without causing the ways to bind.

NOTICE

Excessively loose gibs may cause poor workpiece finishes, and may cause undue wear of sliding surfaces and ways. Over-tightening the gibs may cause premature wear of these sliding devices.

Each sliding surface for the table, saddle, and knee has a tapered gib that is sandwiched between the stationary and moving surfaces. The saddle and knee have a gib on both sides. There are two adjustment screws, one on each end of each gib, that move the tapered gib back and forth, increasing or decreasing friction of the sliding surfaces.

DISCONNECT MILL FROM POWER BEFORE ADJUSTING THE GIBS!

Loosen one adjustment screw and tighten the other the same amount to move the gib until you feel a slight drag in that path of movement.

Refer to **Figures 60–62** for the locations of the table, saddle, and knee gib adjustment screws.

Tools Needed	Qty
Flat Head Screwdriver	1

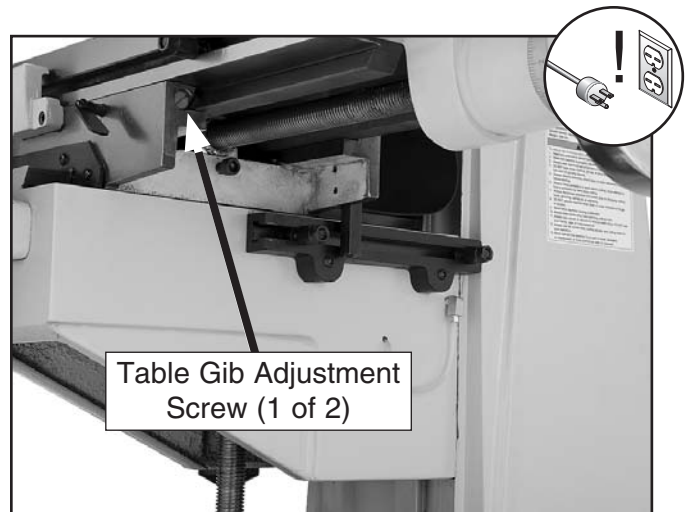

Figure 60. Table gib adjustment screw (1 of 2).



Figure 61. Saddle gib adjustment screw (1 of 2).



Figure 62. Knee gib adjustment screw (1 of 2).



Adjusting Backlash

Leadscrew backlash is the amount of motion the leadscrew rotates before the device begins to move. Leadscrews always have a certain amount of backlash that will increase with wear. Generally, 0.005"–0.010" of backlash is acceptable.

The backlash of the longitudinal and cross leadscrew can be adjusted by changing the gap in the leadscrew nuts (see **Figures 63–64**).

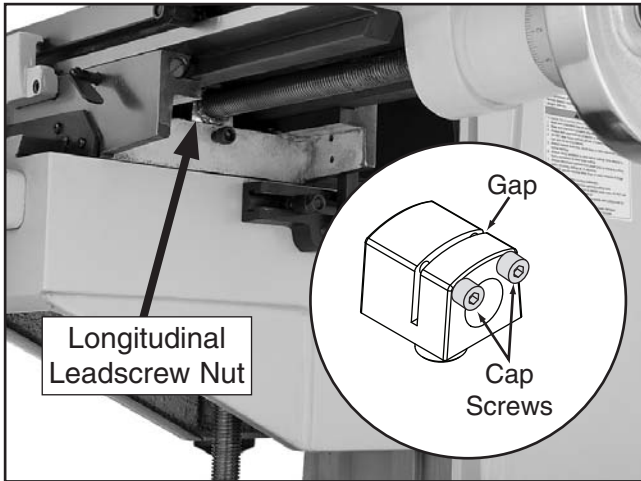

Figure 63. Longitudinal leadscrew nut.

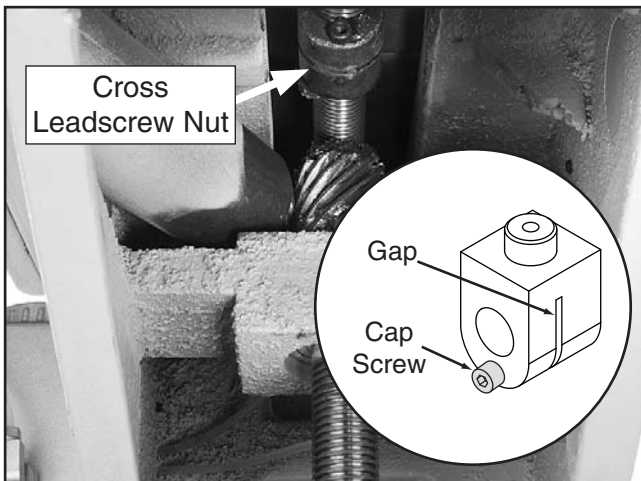

Figure 64. Cross leadscrew nut.

Use a 5mm hex wrench to tighten or loosen the cap screws on the leadscrew nuts shown in **Figures 63–64**, then test the amount of backlash by slowly rocking the handwheels back-and-forth.

V-Belt Replacement

If the belt is cracked, frayed, or shows signs of slipping and glazing you must replace it.

Tools Needed	Qty
Wrench 17mm.....	1
Hex Wrench 5mm.....	1

To replace the V-belt:

1. DISCONNECT MILL FROM POWER!
2. Get an assistant's help, and tilt the headstock to approximately 90 degrees (**Figure 65**), then tighten the headstock tilt lock nuts to hold the headstock in place.



Figure 65. Headstock tilted to 90 degrees.

3. Using a Phillips screwdriver, remove one of the belt access plates.



- Using a 5mm hex wrench, remove the belt cover by pulling the four cap screws (**Figure 66**).

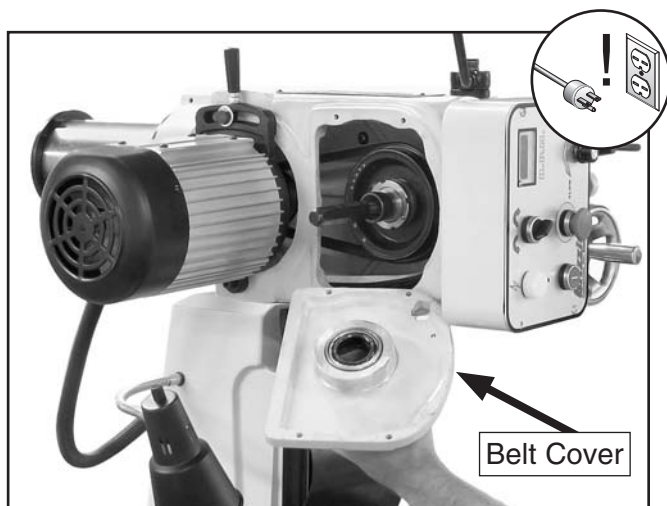

Figure 66. Belt cover removal.

- Using a 17mm wrench, loosen the lock bolt, use the belt tension lever to de-tension the belt, then remove the belt.
- Install a new belt.

- Push firmly and hold the belt tension lever toward the rear of the machine and re-tighten the lock bolt (**Figure 67**). No belt deflection is required.



Figure 67. V-belt tension lever.

- Re-install the belt cover, the belt access plate, and return the headstock to the vertical position.

SECTION 8: WIRING

These pages are current at the time of printing. However, in the spirit of improvement, we may make changes to the electrical systems of future machines. Study this section carefully. If there are differences between your machine and what is shown in this section, call Technical Support at (570) 546-9663 for assistance BEFORE making any changes to the wiring on your machine.

WARNING

Wiring Safety Instructions

SHOCK HAZARD. Working on wiring that is connected to a power source is extremely dangerous. Touching electrified parts will result in personal injury including but not limited to severe burns, electrocution, or death. Disconnect the power from the machine before servicing electrical components!

MODIFICATIONS. Modifying the wiring beyond what is shown in the diagram may lead to unpredictable results, including serious injury or fire. This includes the installation of unapproved after-market parts.

WIRE CONNECTIONS. All connections must be tight to prevent wires from loosening during machine operation. Double-check all wires disconnected or connected during any wiring task to ensure tight connections.

CIRCUIT REQUIREMENTS. You MUST follow the requirements at the beginning of this manual when connecting your machine to a power source.

WIRE/COMPONENT DAMAGE. Damaged wires or components increase the risk of serious personal injury, fire, or machine damage. If you notice that any wires or components are damaged while performing a wiring task, replace those wires or components.

MOTOR WIRING. The motor wiring shown in these diagrams is current at the time of printing but may not match your machine. If you find this to be the case, use the wiring diagram inside the motor junction box.















CAPACITORS/INVERTERS. Some capacitors and power inverters store an electrical charge for up to 10 minutes after being disconnected from the power source. To reduce the risk of being shocked, wait at least this long before working on capacitors.

EXPERIENCING DIFFICULTIES. If you are experiencing difficulties understanding the information included in this section, contact our Technical Support at (570) 546-9663.

NOTICE

The photos and diagrams included in this section are best viewed in color. You can view these pages in color at www.grizzly.com.

COLOR KEY

BLACK		BLUE		YELLOW		LIGHT BLUE	
WHITE		BROWN		YELLOW GREEN		BLUE WHITE	
GREEN		GRAY		PURPLE		TURQUOISE	
RED		ORANGE		PINK			



Wiring Diagram

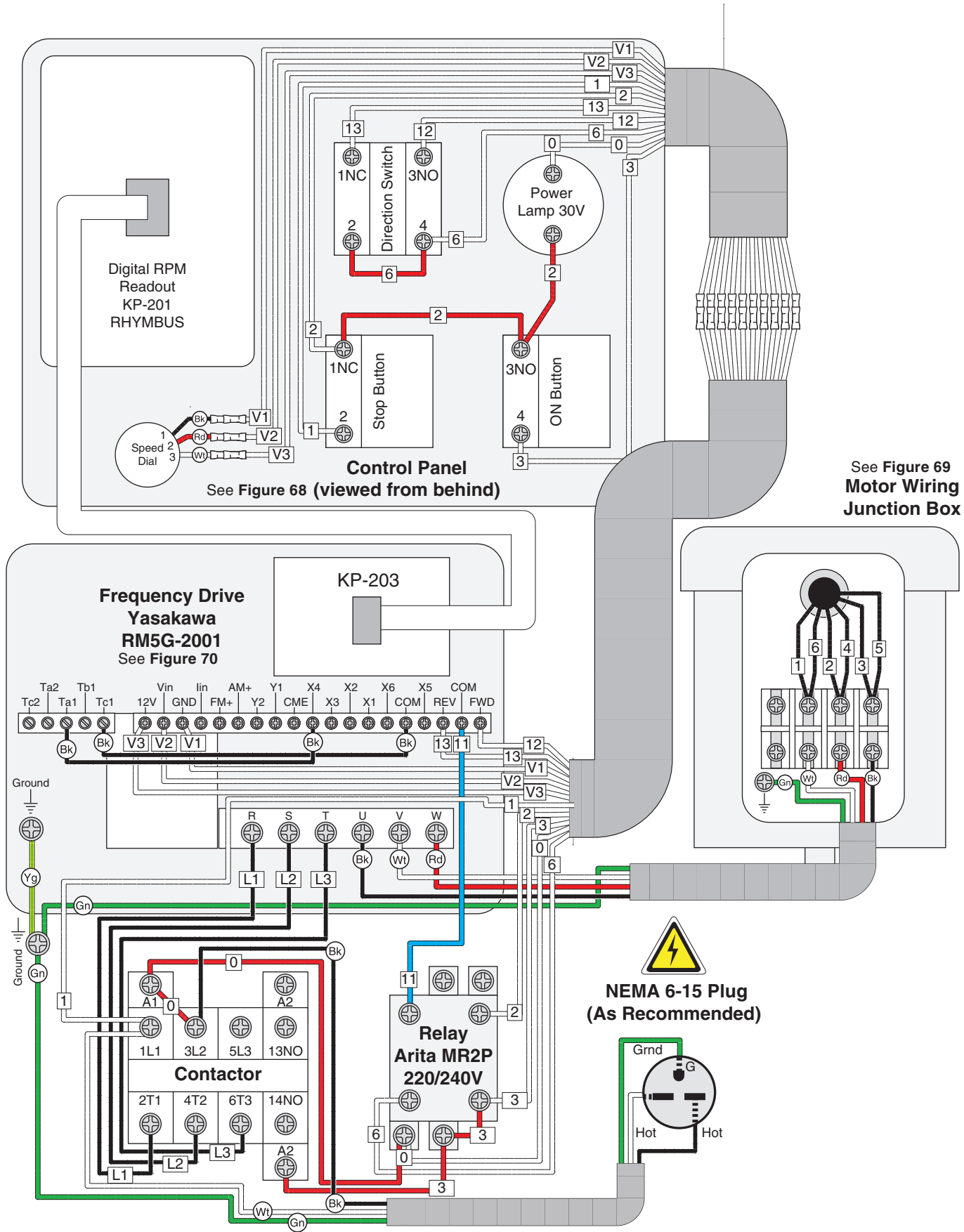

Electrical Components



Figure 68. Control panel wiring.



Figure 70. Wiring component location.

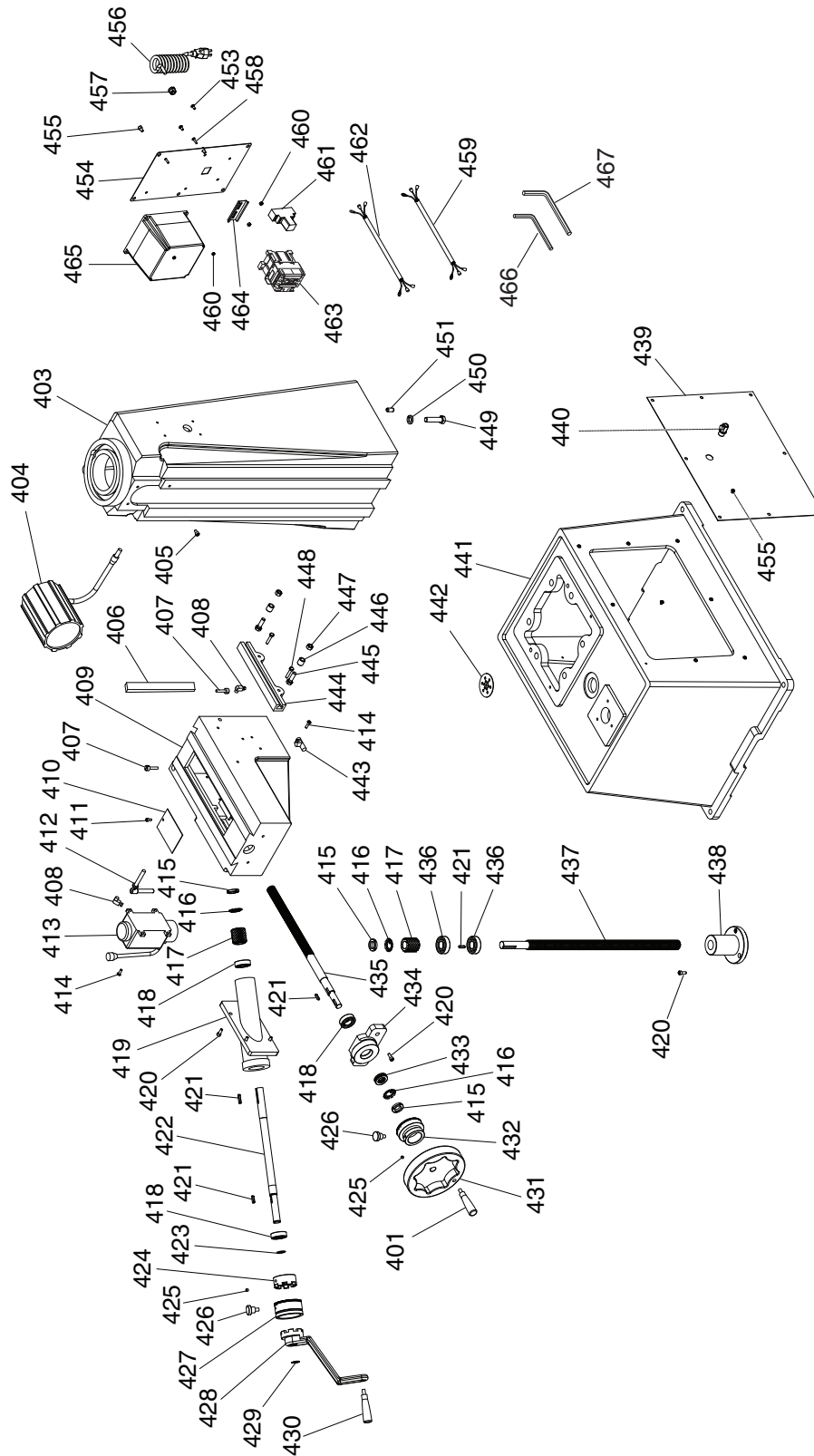

Figure 69. Tachometer sensor location.



SECTION 9: PARTS

Base, Column, & Knee Breakdown



Base, Column, & Knee Parts List

REF	PART #	DESCRIPTION
401	P0695301	HANDWHEEL HANDLE
403	P0695403	COLUMN
404	P0695404	HALOGEN LAMP ASSEMBLY
405	PCAP68M	CAP SCREW M6-1 X 8
406	P0695406	KNEE GIB
407	P0695407	GIB ADJUSTMENT SCREW
408	P0695408	PIPE JOINT
409	P0695409	KNEE
410	P0695410	KNEE SLIDE COVER
411	PS40M	PHLP HD SCR M5-.8 X 16
412	P0695412	KNEE LOCK LEVER
413	P0695413	ONE-SHOT OILER ASSEMBLY
414	PS20M	PHLP HD SCR M5-.8 X 15
415	P0695320	SPANNER NUT 20MM
416	P0695416	SPANNER LOCK WASHER 20MM
417	P0695417	BEVEL GEAR
418	P6004ZZ	BALL BEARING 6004ZZ
419	P0695419	GEAR SHAFT SLEEVE
420	PCAP01M	CAP SCREW M6-1 X 16
421	PK34M	KEY 5 X 5 X 20
422	P0695422	GEAR SHAFT
423	PR09M	EXT RETAINING RING 20MM
424	P0695424	CLUTCH
425	PSS03M	SET SCREW M6-1 X 8
426	P0695144	DIAL POSITIONING SCREW
427	P0695427	ELEVATION GRADUATED DIAL
428	P0695428	CRANK
429	PR07M	EXT RETAINING RING 18MM
430	P0695142	CRANK HANDLE
431	P0695304	HANDWHEEL
432	P0695305	CROSS GRADUATED DIAL
433	P51104	THRUST BEARING 51104
434	P0695434	BEARING HOUSING

REF	PART #	DESCRIPTION
435	P0695435	CROSS LEADSCREW
436	P6204ZZ	BALL BEARING 6204ZZ
437	P0695437	ELEVATION LEADSCREW
438	P0695438	PEDESTAL
439	P0695439	BASE SIDE COVER
440	P0695440	STRAIN RELIEF
441	P0695441	BASE
442	P0695442	DRAIN SCREEN
443	P0695443	LIMIT BLOCK
444	P0695444	LIMIT TRACK
445	PB01M	HEX BOLT M10-1.5 X 30
446	P0695322	TABLE STOP SLEEVE
447	PN02M	HEX NUT M10-1.5
448	PB29M	HEX BOLT M6-1 X 30
449	PB72	HEX BOLT 1/2-13 X 2
450	PLW07	LOCK WASHER 1/2
451	P0695451	PIN 10 X 20
453	PS01	PHLP HD SCR 10-24 X 1/2
454	P0695454	COLUMN COVER
455	PS03M	PHLP HD SCR M6-1 X 8
456	PWRCRD220L	POWER CORD
457	P0695457	STRAIN RELIEF
458	PS08	PHLP HD SCR 10-24 X 3/4
459	P0695459	CORD 3-WIRE
460	PN07	HEX NUT 10-24
461	P0695461	RELAY ARITA MR20 220V
462	P0695462	CORD 4-WIRE
463	P0695463	CONTACTOR NHD C-12D
464	P0695464	MOUNTING TRACK
465	P0695465	INVERTER YASKAWA RM56-2001
466	PAW04M	HEX WRENCH 4MM
467	PAW05M	HEX WRENCH 5MM



Head Breakdown

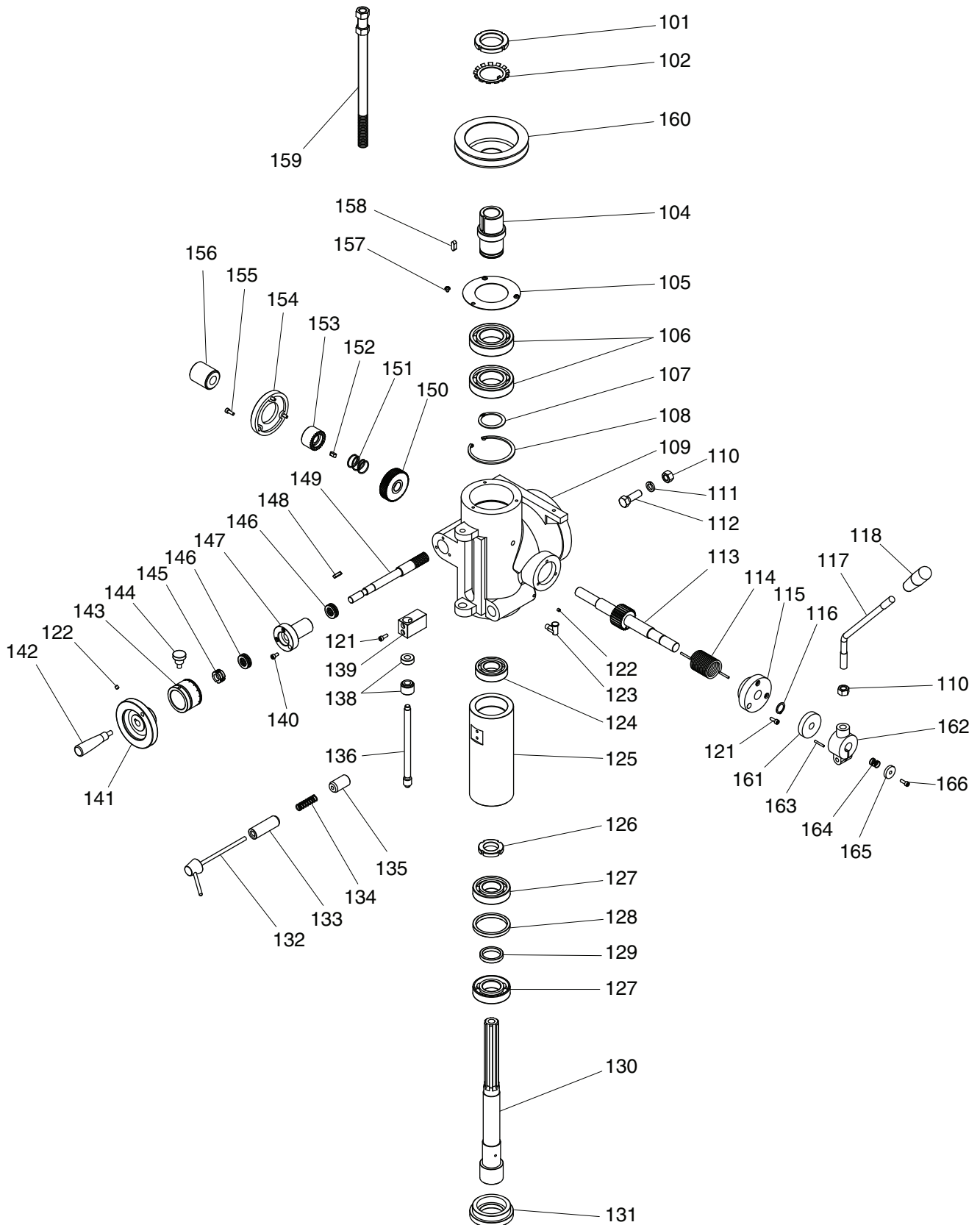

Head Parts List

REF	PART #	DESCRIPTION
101	P0695101	SPANNER NUT 45MM
102	P0695102	SPANNER LOCK WASHER 45MM
104	P0695104	SPLINE SLEEVE
105	P0695105	BEARING COVER
106	P6209ZZ	BALL BEARING 6209ZZ
107	PR56M	EXT RETAINING RING 45MM
108	P0695108	INT RETAINING RING 82MM
109	P0695109	HEAD CASTING
110	PN06	HEX NUT 1/2-13
111	PLW07	LOCK WASHER 1/2
112	PB55	HEX BOLT 1/2-13 X 1-1/2
113	P0695113	GEAR SHAFT
114	P0695114	TORSION SPRING
115	P0695115	FLANGE COVER
116	PR08M	EXT RETAINING RING 19MM
117	P0695117	DOWNFEED LEVER
118	P0695118	DOWNFEED LEVER KNOB
121	PCAP24M	CAP SCREW M5-.8 X 16
122	PSS03M	SET SCREW M6-1 X 8
123	P0695123	OIL CUP
124	P6206ZZ	BALL BEARING 6206ZZ
125	P0695125	QUILL
126	P0695126	SPANNER NUT 35MM
127	P7207	ANGULAR CONTACT BEARING 7207
128	P0695128	BEARING WASHER BIG
129	P0695129	BEARING WASHER SMALL
130	P0695130	SPINDLE
131	P0695131	SPINDLE NUT
132	P0695132	SPINDLE LOCK SHAFT
133	P0695133	LOCK PLUNGER LARGE
134	P0695134	COMPRESSION SPRING

REF	PART #	DESCRIPTION
135	P0695135	LOCK PLUNGER SMALL
136	P0695136	DEPTH SCREW
138	P0695138	DEPTH ADJUSTMENT NUT
139	P0695139	THREADED BRACKET
140	PS09M	PHLP HD SCR M5-.8 X 10
141	P0695141	HANDWHEEL
142	P0695142	HANDWHEEL HANDLE
143	P0695143	FINE GRADUATED DIAL
144	P0695144	DIAL POSITIONING SCREW
145	P0695145	SPECIAL NUT 9/16-12
146	P51102	THRUST BEARING 51102
147	P0695147	FLANGE SLEEVE
148	PK34M	KEY 5 X 5 X 20
149	P0695149	WORM SHAFT
150	P0695150	COUPLING WORM GEAR
151	P0695151	COMPRESSION SPRING
152	PK99M	KEY 6 X 6 X 15
153	P0695153	CLUTCH
154	P0695154	END CAP
155	PS09M	PHLP HD SCR M5-.8 X 10
156	P0695156	DOWNFEED SELECTOR KNOB
157	PS05M	PHLP HD SCR M5-.8 X 8
158	P0695158	SPECIAL KEY
159	P0695159	DRAWBAR
160	P0695160	SPINDLE PULLEY
161	P0695161	SPACER
162	P0695162	LEVER HUB
163	P0695163	SPECIAL PIN
164	P0695164	COMPRESSION SPRING
165	P0695165	SPECIAL FLAT WASHER
166	PCAP38M	CAP SCREW M5-.8 X 25



Motor & Ram Breakdown

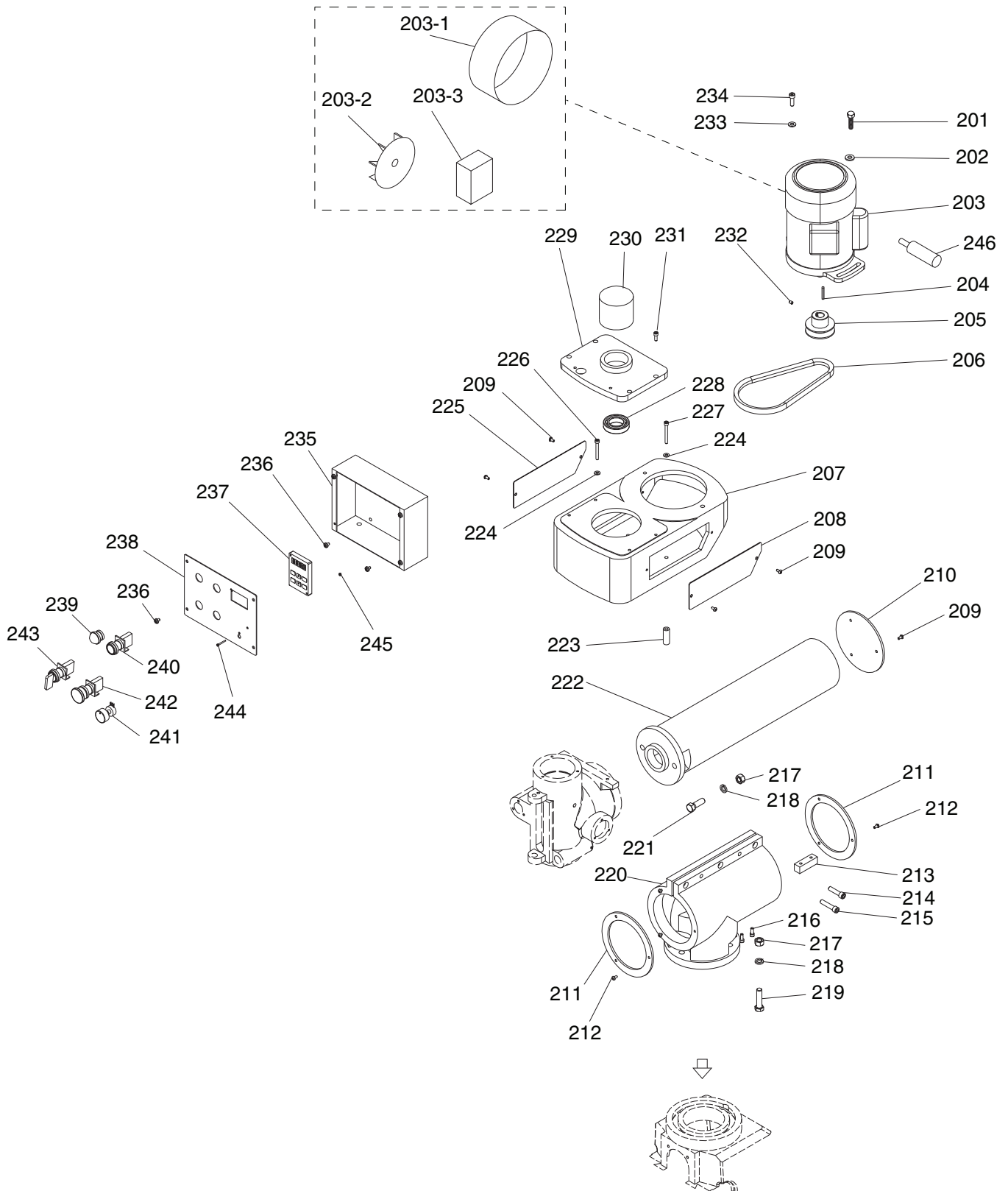

Motor & Ram Parts List

REF	PART #	DESCRIPTION
201	PB24	HEX BOLT 3/8-16 X 1-1/4
202	PW04M	FLAT WASHER 10MM
203	P0695203	MOTOR 1-1/2HP 220V 3PH
203-1	P0695203-1	MOTOR FAN COVER
203-2	P0695203-2	MOTOR FAN
203-3	P0695203-3	MOTOR WIRING JUNCTION BOX
204	PK02M	KEY 5 X 5 X 40
205	P0695205	MOTOR PULLEY
206	PVB28	V-BELT 5L280
207	P0695207	V-BELT HOUSING
208	P0695208	RIGHT V-BELT COVER
209	PS08M	PHLP HD SCR M5-.8 X 12
210	P0695210	RAM END COVER
211	P0695211	RAM FLANGE
212	PCAP04M	CAP SCREW M6-1 X 10
213	P0695213	RAM GIB
214	PCAP72M	CAP SCREW M10-1.5 X 30
215	PCAP47M	CAP SCREW M10-1.5 X 40
216	PCAP02M	CAP SCREW M6-1 X 20
217	PN06	HEX NUT 1/2-13
218	PLW07	LOCK WASHER 1/2
219	PB56	HEX BOLT 1/2-13 X 1-3/4
220	P0695220	RAM HOUSING
221	PB55	HEX BOLT 1/2-13 X 1-1/2
222	P0695222	RAM

REF	PART #	DESCRIPTION
223	P0695223	BUSHING
224	PW03M	FLAT WASHER 6MM
225	P0695225	LEFT V-BELT COVER
226	PCAP37M	CAP SCREW M6-1 X 50
227	PCAP83M	CAP SCREW M6-1 X 55
228	P6007ZZ	BALL BEARING 6007ZZ
229	P0695229	BEARING COVER
230	P0695230	DRAWBAR COVER
231	PCAP02M	CAP SCREW M6-1 X 20
232	PSS03M	SET SCREW M6-1 X 8
233	PW01M	FLAT WASHER 8MM
234	PCAP31M	CAP SCREW M8-1.25 X 25
235	P0695235	CONTROL BOX
236	PS11M	PHLP HD SCR M6-1 X 16
237	P0695237	SPINDLE SPEED READOUT UNIT
238	P0695238	CONTROL PANEL
239	P0695239	POWER LIGHT
240	P0695240	ON/OFF BUTTON
241	P0695241	SPINDLE SPEED DIAL
242	P0695242	STOP BUTTON
243	P0695243	SPINDLE DIRECTION SWITCH
244	PS34	PHLP HD SCR M3-.5 X 25
245	PN07M	HEX NUT M3-.5
246	P0695246	HANDLE



Table Breakdown

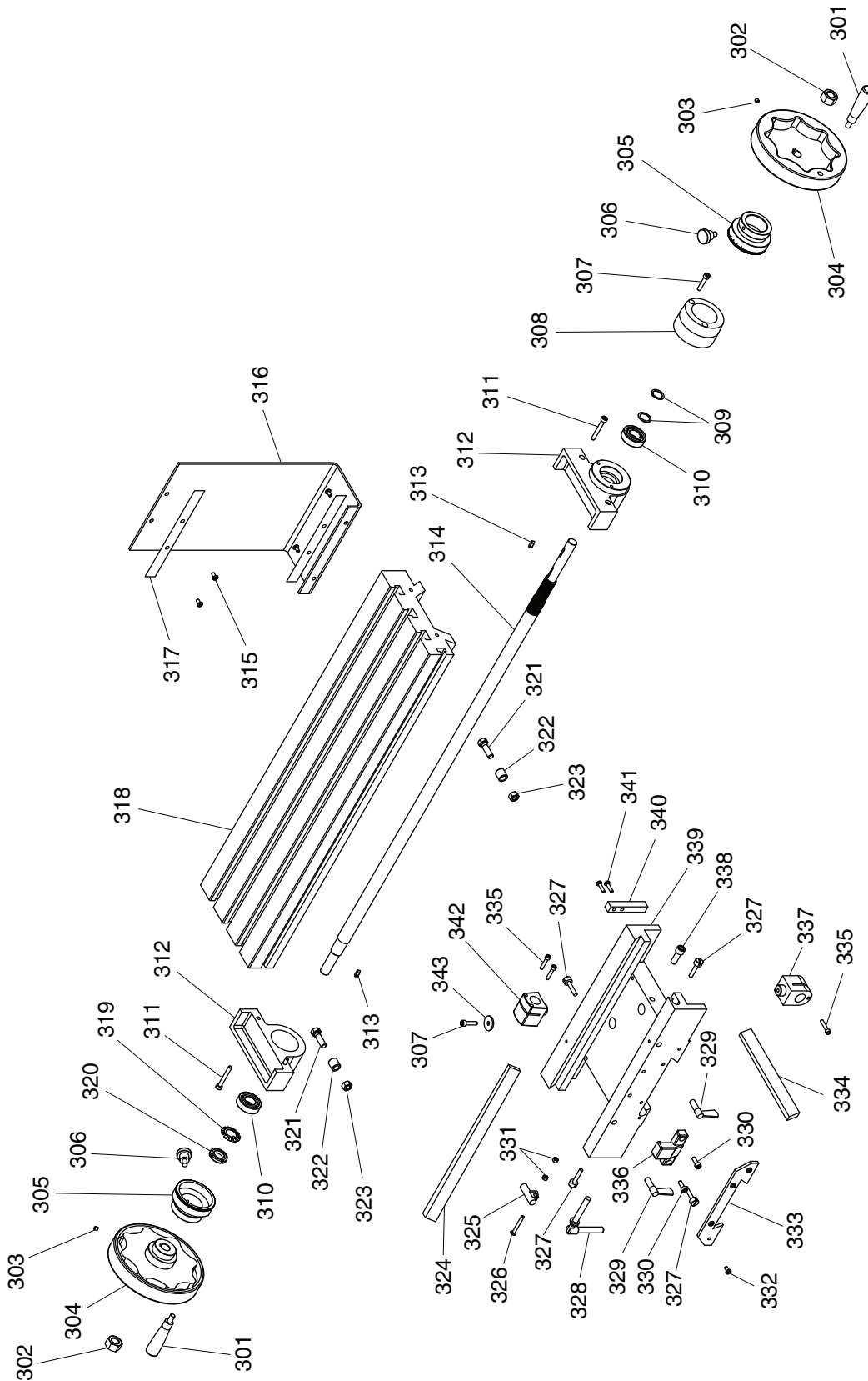

Table Parts List

REF	PART #	DESCRIPTION
301	P0695301	HANDWHEEL HANDLE
302	PN04	HEX NUT 5/8-11
303	PSS03M	SET SCREW M6-1 X 8
304	P0695304	HANDWHEEL
305	P0695305	LONGITUDINAL GRADUATED DIAL
306	P0695306	DIAL POSITIONING SCREW
307	PCAP06M	CAP SCREW M6-1 X 25
308	P0695308	SPACER
309	PR09M	EXT RETAINING RING 20MM
310	P6004ZZ	BALL BEARING 6004ZZ
311	PCAP30M	CAP SCREW M6-1 X 45
312	P0695312	LEADSCREW BRACKET
313	PK34M	KEY 5 X 5 X 20
314	P0695314	LONGITUDINAL LEADSCREW
315	PS03M	PHLP HD SCR M6-1 X 8
316	P0695316	WAY COVER
317	P0695317	WAY COVER HOLDER
318	P0695318	TABLE
319	P0695319	SPANNER LOCK WASHER 20MM
320	P0695320	SPANNER NUT 20MM
321	PB01M	HEX BOLT M10-1.5 X 30
322	P0695322	TABLE STOP SLEEVE

REF	PART #	DESCRIPTION
323	PN02M	HEX NUT M10-1.5
324	P0695324	LONGITUDINAL GIB
325	P0695325	LIMIT STOP
326	PS60M	PHLP HD SCR M5-.8 X 30
327	P0695327	GIB ADJUSTMENT SCREW
328	P0695328	CROSS LOCK HANDLE
329	P0695329	LONGITUDINAL LOCK HANDLE
330	PCAP01M	CAP SCREW M6-1 X 16
331	PN06M	HEX NUT M5-.8
332	PS09M	PHLP HD SCR M5-.8 X 10
333	P0695333	WAY WIPER
334	P0695334	CROSS GIB
335	PCAP31M	CAP SCREW M8-1.25 X 25
336	P0695336	LIMIT BRACKET
337	P0695337	CROSS LEADSCREW NUT
338	PCAP31M	CAP SCREW M8-1.25 X 25
339	P0695339	SADDLE
340	P0695340	LIMIT BLOCK
341	PS06M	PHLP HD SCR M5-.8 X 20
342	P0695342	LONGITUDINAL LEADSCREW NUT
343	PW03M	FLAT WASHER 6MM



Label Placement

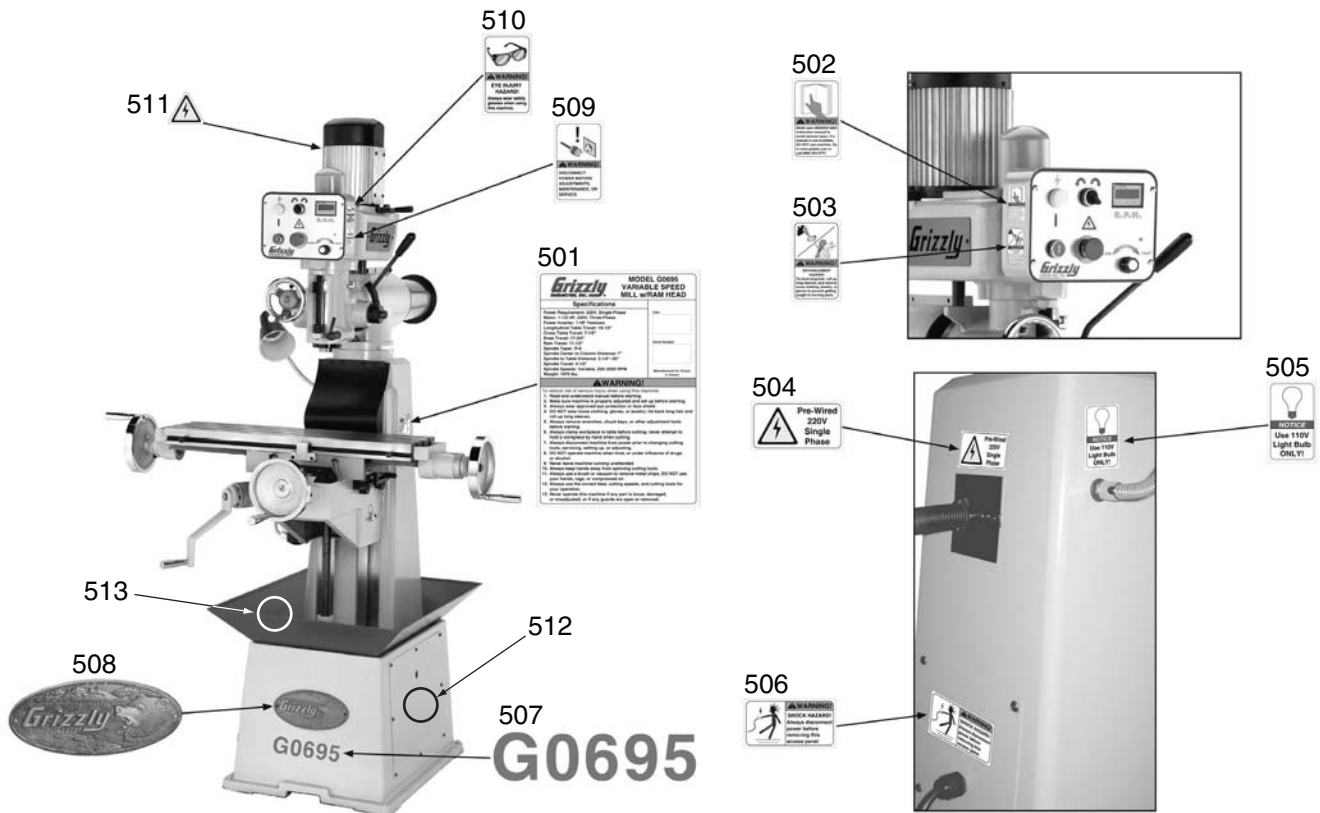

REF	PART #	DESCRIPTION
501	P0695501	MACHINE ID LABEL
502	PLABEL-12A	READ MANUAL LABEL
503	PLABEL-55	ENTANGLEMENT HAZARD LABEL
504	P0695504	PREWIRED 220V LABEL
505	P0695505	LIGHT BULB 110V LABEL
506	PLABEL-64B	ELECTROCUTION HAZARD LABEL
507	P0695507	MODEL NUMBER LABEL

REF	PART #	DESCRIPTION
508	G8588	GRIZZLY OVAL NAMEPLATE
509	PLABEL-63	DISCONNECT WARNING LABEL
510	PLABEL-11A	EYE INJURY WARNING LABEL
511	PLABEL-14A	ELECTRICITY LABEL
512	PPAINT-11	GRIZZLY PUTTY TOUCH-UP PAINT
513	PPAINT-1	GRIZZLY GREEN TOUCH-UP PAINT

WARNING

Safety labels warn about machine hazards and ways to prevent injury. The owner of this machine **MUST** maintain the original location and readability of the labels on the machine. If any label is removed or becomes unreadable, **REPLACE** that label before using the machine again. Contact Grizzly at (800) 523-4777 or www.grizzly.com to order new labels.





WARRANTY CARD

Name _____
 Street _____
 City _____ State _____ Zip _____
 Phone # _____ Email _____ Invoice # _____
 Model # _____ Order # _____ Serial # _____

The following information is given on a voluntary basis. It will be used for marketing purposes to help us develop better products and services. **Of course, all information is strictly confidential.**

1. How did you learn about us?

Advertisement Friend Catalog
 Card Deck Website Other:

2. Which of the following magazines do you subscribe to?

<input type="checkbox"/> Cabinetmaker & FDM	<input type="checkbox"/> Popular Science	<input type="checkbox"/> Wooden Boat
<input type="checkbox"/> Family Handyman	<input type="checkbox"/> Popular Woodworking	<input type="checkbox"/> Woodshop News
<input type="checkbox"/> Hand Loader	<input type="checkbox"/> Precision Shooter	<input type="checkbox"/> Woodsmith
<input type="checkbox"/> Handy	<input type="checkbox"/> Projects in Metal	<input type="checkbox"/> Woodwork
<input type="checkbox"/> Home Shop Machinist	<input type="checkbox"/> RC Modeler	<input type="checkbox"/> Woodworker West
<input type="checkbox"/> Journal of Light Cont.	<input type="checkbox"/> Rifle	<input type="checkbox"/> Woodworker's Journal
<input type="checkbox"/> Live Steam	<input type="checkbox"/> Shop Notes	<input type="checkbox"/> Other:
<input type="checkbox"/> Model Airplane News	<input type="checkbox"/> Shotgun News	
<input type="checkbox"/> Old House Journal	<input type="checkbox"/> Today's Homeowner	
<input type="checkbox"/> Popular Mechanics	<input type="checkbox"/> Wood	

3. What is your annual household income?

\$20,000-\$29,000 \$30,000-\$39,000 \$40,000-\$49,000
 \$50,000-\$59,000 \$60,000-\$69,000 \$70,000+

4. What is your age group?

20-29 30-39 40-49
 50-59 60-69 70+

5. How long have you been a woodworker/metalworker?

0-2 Years 2-8 Years 8-20 Years 20+ Years

6. How many of your machines or tools are Grizzly?

0-2 3-5 6-9 10+

7. Do you think your machine represents a good value? Yes No

8. Would you recommend Grizzly Industrial to a friend? Yes No

9. Would you allow us to use your name as a reference for Grizzly customers in your area?
Note: We never use names more than 3 times. Yes No

10. Comments: _____

CUT ALONG DOTTED LINE

FOLD ALONG DOTTED LINE



Place
Stamp
Here



GRIZZLY INDUSTRIAL, INC.
P.O. BOX 2069
BELLINGHAM, WA 98227-2069



FOLD ALONG DOTTED LINE

Send a Grizzly Catalog to a friend:

Name _____
Street _____
City _____ State _____ Zip _____

TAPE ALONG EDGES--PLEASE DO NOT STAPLE

WARRANTY AND RETURNS

Grizzly Industrial, Inc. warrants every product it sells for a period of **1 year** to the original purchaser from the date of purchase. This warranty does not apply to defects due directly or indirectly to misuse, abuse, negligence, accidents, repairs or alterations or lack of maintenance. This is Grizzly's sole written warranty and any and all warranties that may be implied by law, including any merchantability or fitness, for any particular purpose, are hereby limited to the duration of this written warranty. We do not warrant or represent that the merchandise complies with the provisions of any law or acts unless the manufacturer so warrants. In no event shall Grizzly's liability under this warranty exceed the purchase price paid for the product and any legal actions brought against Grizzly shall be tried in the State of Washington, County of Whatcom.

We shall in no event be liable for death, injuries to persons or property or for incidental, contingent, special, or consequential damages arising from the use of our products.

To take advantage of this warranty, contact us by mail or phone and give us all the details. We will then issue you a "Return Number," which must be clearly posted on the outside as well as the inside of the carton. We will not accept any item back without this number. Proof of purchase must accompany the merchandise.

The manufacturers reserve the right to change specifications at any time because they constantly strive to achieve better quality equipment. We make every effort to ensure that our products meet high quality and durability standards and we hope you never need to use this warranty.

Please feel free to write or call us if you have any questions about the machine or the manual.

Thank you again for your business and continued support. We hope to serve you again soon.

grizzly.com[®]

TOOL WEBSITE

Buy Direct and Save with Grizzly[®] – Trusted, Proven and a Great Value!
~Since 1983~

*Visit Our Website Today For
Current Specials!*

**ORDER
24 HOURS A DAY!
1-800-523-4777**



Free Manuals Download Website

<http://myh66.com>

<http://usermanuals.us>

<http://www.somanuals.com>

<http://www.4manuals.cc>

<http://www.manual-lib.com>

<http://www.404manual.com>

<http://www.luxmanual.com>

<http://aubethermostatmanual.com>

Golf course search by state

<http://golfingnear.com>

Email search by domain

<http://emailbydomain.com>

Auto manuals search

<http://auto.somanuals.com>

TV manuals search

<http://tv.somanuals.com>