

Catalog Number 8990

# **Sigma 900 MAX Refrigerated Sampler**

INSTRUMENT MANUAL

07/03 4ed





Catalog Number 8990

# **Sigma 900 MAX Refrigerated Sampler**

INSTRUMENT MANUAL

© Hach Company, 2002, 2003. All rights reserved. Printed in the U.S.A.  
eac 07/03 4ed



Safety Precautions .....	7
Specifications .....	9
<b>Section 1 Introduction</b> .....	<b>15</b>
1.1 Controller Cover .....	15
1.2 Front Panel .....	15
1.2.1 Keypad Description .....	16
1.2.2 Liquid Crystal Display .....	16
1.2.3 Internal Humidity Indicator .....	17
1.3 Interface Connectors .....	18
1.3.1 Receptacle Caps .....	18
1.4 Principle of Operation .....	19
1.4.1 Liquid Sensing .....	19
<b>INSTALLATION</b> .....	<b>21</b>
<b>Section 2 Installation</b> .....	<b>23</b>
2.1 Unpacking the Instrument .....	23
2.2 Selecting the Installation Site .....	23
2.3 Installing the Pump Tube in the Sensor Body .....	24
2.3.1 Attaching the Intake Line .....	25
2.3.1.1 Attaching the Vinyl Tubing .....	25
2.3.1.2 Attaching the Teflon®-Lined Tubing .....	25
2.3.2 Setting Up the Intake Line and Strainer .....	26
2.4 Choosing Bottle and Retainer Configurations .....	26
2.5 Setting Up the Bottles .....	27
2.5.1 One-Bottle Sampling .....	27
2.5.2 Two- and Four-bottle Sampling .....	27
2.5.3 Eight-, 12-, or 24-bottle Sampling .....	28
2.6 Installing the Distributor (Multiple Bottle Operation) .....	29
2.6.1 Distributor Arm Alignment .....	30
2.7 Installing the Full-Bottle Shut-Off Device (Single Bottle Operation) .....	31
2.8 Power Connections .....	31
2.9 Auxiliary Receptacle Pin Identification .....	32
2.9.1 Splitter Interface .....	33
<b>OPERATION</b> .....	<b>35</b>
<b>Section 3 Basic Programming Setup</b> .....	<b>37</b>
3.1 Initial Power-Up of Sampler .....	37
3.2 Basic Programming Setup .....	37
3.3 Advanced Sampling .....	49
<b>Section 4 Sensor Setup</b> .....	<b>61</b>
4.1 Downlook Ultrasonic Sensor .....	61
4.1.1 Downlook Ultrasonic Sensor Connection .....	61
4.1.2 Downlook Ultrasonic Sensor Programming .....	61

# Table of Contents

---

4.1.3 Downlook Ultrasonic Sensor Calibration .....	61
4.1.3.1 Liquid Depth.....	61
4.1.3.2 Sensor Height .....	62
4.1.3.3 Setting the Invisible Range .....	62
4.2 Submerged Area/Velocity Sensor .....	63
4.2.1 Submerged Area/Velocity Sensor Connection.....	63
4.2.2 Submerged Area/Velocity Sensor Programming .....	63
4.2.3 Submerged Area/Velocity Submerged Area/Velocity Sensor Calibration .....	64
4.3 Submerged Pressure Sensor.....	65
4.3.1 Submerged Pressure Sensor Connection .....	65
4.3.2 Submerged Pressure Sensor Programming.....	66
4.3.3 Submerged Pressure Sensor Calibration .....	66
<b>Section 5 Optional Device Installation.....</b>	<b>69</b>
5.1 Rain Gauge .....	69
5.1.1 Rain Gauge Programming.....	70
5.2 pH Probe .....	70
5.2.1 pH Probe Connection .....	70
5.2.2 pH Probe Programming .....	71
5.2.3 pH Probe Calibration .....	71
5.3 ORP Probe.....	72
5.3.1 ORP Probe Connection .....	72
5.3.2 ORP Probe Programming.....	73
5.3.3 ORP Probe Calibration .....	73
5.3.3.1 ORP Preamplifier/Junction Box Calibration .....	73
5.4 Dissolved Oxygen Probe.....	74
5.4.1 Dissolved Oxygen Probe Connection .....	74
5.4.2 Dissolved Oxygen Probe Programming.....	74
5.4.3 Dissolved Oxygen Probe Temperature Programming .....	75
5.4.4 Dissolved Oxygen Probe Calibration .....	75
5.5 Conductivity Probe .....	76
5.5.1 Conductivity Probe Connection .....	76
5.5.2 Conductivity Probe Programming.....	76
5.5.3 Conductivity Temperature Programming .....	76
5.5.4 Conductivity Probe Calibration .....	77
<b>Section 6 Communication Setup.....</b>	<b>79</b>
6.1 RS232 Cable.....	79
6.1.1 RS232 Connection .....	79
6.1.2 RS232 Programming .....	79
6.2 Modem .....	80
6.2.1 Modem Connection .....	80
6.2.2 Modem Programming .....	80
6.2.2.1 Cellular Communication Option .....	81
6.2.2.2 Reliable Communications .....	82
6.2.2.3 Cellular Modem Scheduling.....	82
6.2.2.4 Cellular Modem Scheduling Basis .....	83
6.2.2.5 Cellular Modem Triggering .....	84
6.2.2.6 Pager Option.....	84
6.2.2.7 Reporting Devices .....	85

6.3 4–20 mA Option .....	87
6.3.1 4–20 mA Connection .....	87
6.3.2 4–20 mA Programming .....	87
6.3.3 4–20 mA Calibration .....	88
6.4 Alarm Relays .....	89
6.4.1 Alarm Relays Connection .....	90
6.4.2 Alarm Relays Programming .....	91
6.4.2.1 Trouble Alarms .....	91
6.4.2.2 Set Point Alarms .....	91
6.5 Analog Inputs .....	93
6.5.1 Analog Inputs Connection .....	93
6.5.2 Analog Inputs Programming .....	94
<b>MAINTENANCE</b> .....	<b>95</b>
<b>Section 7 Maintenance</b> .....	<b>97</b>
7.1 Cleaning the Sampler .....	97
7.1.1 Cleaning the Sampler Cabinet .....	97
7.1.2 Cleaning the Sample Bottles .....	97
7.1.3 Cleaning the Intake Tubing and Pump Tubing .....	97
7.1.4 No Lubrication Required .....	97
7.2 Pump Tubing Maintenance .....	97
7.2.1 Tubing Life Estimates .....	97
7.2.2 Replacing Pump Tubing .....	98
7.3 Upgrades, Repairs, General Maintenance .....	98
Electrostatic Discharge (ESD) Considerations .....	99
7.4 Internal Maintenance Items .....	99
7.5 Removing and Opening the Controller .....	99
7.6 Re-installing the Bottom Panel .....	100
7.7 Circuit Board Identification .....	101
7.8 Replacing the Fuse .....	103
7.9 Motor/Gear Box .....	103
7.10 Internal Desiccant Module .....	103
7.10.1 Replacing the Desiccant .....	103
7.11 Memory Battery .....	104
<b>Appendix A Quick Start Guides</b> .....	<b>105</b>
Sigma 900 MAX Refrigerated Sampler Main Menu Flow Chart .....	105
Sigma 900 MAX Refrigerated Sampler Setup Flow Chart .....	106
Sigma 900 MAX Refrigerated Sampler Options Flow Chart .....	107
Sigma 900 MAX Refrigerated Sampler Advanced Sampling Flow Chart .....	108
Sigma 900 MAX Refrigerated Sampler Alarms Flow Chart .....	109
Sigma 900 MAX Refrigerated Sampler Calibration Flow Chart (1 of 2) .....	110
Sigma 900 MAX Refrigerated Sampler Calibration Flow Chart (2 of 2) .....	111
<b>Appendix B Programming Features</b> .....	<b>113</b>
Review All Items .....	113
Running a Program .....	113
Displaying Data .....	113

# Table of Contents

---

Selecting the Channel .....	114
Tabular or Graph Format.....	114
Graph Manipulation .....	115
Graphic Display Averaging .....	115
Sample History .....	115
Options Menu Features .....	116
Setting the Time and Date .....	116
Volume Calibration .....	116
Data Log .....	119
Logging Intervals .....	119
Dynamic Memory Allocation .....	120
Data Logging Configuration.....	121
Diagnostics .....	121
Load Program.....	124
Screen Saver Mode.....	124
Flow Totalizer .....	125
<b>Appendix C</b> Troubleshooting and Error Messages .....	127
Error Messages .....	127
Trouble Alarm Conditions, Causes, and Solutions .....	129
Downlook Ultrasonic Sensor Troubleshooting.....	130
pH Troubleshooting .....	131
Sigma 900 MAX Refrigerated Sampler Troubleshooting Issues .....	132
<b>Appendix D</b> How to Calculate Pulses/Counts.....	133
<b>Appendix E</b> Exploded Drawings .....	137
Sigma 900 MAX Refrigerated Sampler Assembly Drawing (1 of 3) .....	137
Sigma 900 MAX Refrigerated Sampler Assembly Drawing (2 of 3) .....	138
Sigma 900 MAX Refrigerated Sampler Assembly Drawing (3 of 3) .....	139
Sigma 900 MAX Refrigerated Composite Sampler Assembly.....	140
Sigma 900 Composite Refrigerator Assembly.....	141
Sigma 900 MAX Refrigerated Discrete Sampler Assembly.....	142
Sigma 900 Discrete Refrigerator Assembly.....	143
Transition Tray Assembly .....	144
Sigma 900 MAX Refrigerated Sampler Reference Dimensions .....	145
<b>GENERAL INFORMATION</b> .....	147
Parts and Accessories .....	149
Contact Information for U.S.A. and Outside Europe .....	153
Contact Information for Europe .....	154
Warranty .....	155



Please read this entire manual before unpacking, setting up, or operating this instrument.

Pay particular attention to all danger and caution statements. Failure to do so could result in serious injury to the operator or damage to the equipment.

To ensure the protection provided by this equipment is not impaired, do not use or install this equipment in any manner other than that which is specified in this manual.

## Use of Hazard Information

If multiple hazards exist, this manual will use the signal word (Danger, Caution, Note) corresponding to the greatest hazard.

### **DANGER**

*Indicates a potentially or imminently hazardous situation which, if not avoided, could result in death or serious injury.*

### **CAUTION**









*Indicates a potentially hazardous situation that may result in minor or moderate injury.*

### **NOTE**

*Information that requires special emphasis.*

## Precautionary Labels

Read all labels and tags attached to the instrument. Personal injury or damage to the instrument could occur if not observed.

	This symbol, if noted on the instrument, references the instruction manual for operation and/or safety information.
	This symbol, when noted on a product enclosure or barrier, indicates that a risk of electrical shock and/or electrocution exists and indicates that only individuals qualified to work with hazardous voltages should open the enclosure or remove the barrier.
	This symbol, when noted on the product, identifies the location of a fuse or current limiting device.
	This symbol, when noted on the product, indicates that the marked item can be hot and should not be touched without care.
	This symbol, when noted on the product, indicates the presence of devices sensitive to Electro-static Discharge and indicates that care must be taken to prevent damage to them.
	This symbol, when noted on the product, identifies a risk of chemical harm and indicates that only individuals qualified and trained to work with chemicals should handle chemicals or perform maintenance on chemical delivery systems associated with the equipment.
	This symbol, if noted on the product, indicates the need for protective eye wear.
	This symbol, when noted on the product, identifies the location of the connection for Protective Earth (ground).

## Hazardous Locations

The Sigma 900 MAX Refrigerated Sampler is not approved for use in hazardous locations as defined in the National Electrical Code.

### **DANGER**

*Although some Sigma products are designed and certified for installation in hazardous locations as defined by the National Electrical Code, many Sigma products are not suitable for use in hazardous locations. It is the responsibility of the individuals who are installing the products in hazardous locations to determine the acceptability of the product for the environment. Additionally, to ensure safety, the installation of instrumentation in hazardous locations must be per the manufacturer's control drawing specifications. Any modification to the instrumentation or the installation is not recommended and may result in life threatening injury and/or damage to facilities.*

### **DANGER**

*Bien que certains produits Sigma soient conçus et certifiés pour être installés dans des endroits dangereux tels que définis par le National Electric Code, de nombreux produits Sigma ne conviennent pas pour de tels endroits. Il relève de la responsabilité des personnes qui placent les produits dans des endroits dangereux de déterminer s'ils sont adaptés à cet environnement. En outre, à des fins de sécurité, le placement de machines dans des endroits dangereux doit s'effectuer dans le respect des consignes des schémas de contrôle du fabricant. Toute modification apportée aux machines ou tout déplacement de celles-ci est déconseillé, car susceptible de provoquer des accidents matériels et/ou corporels.*

## Confined Space Entry

***Important Note:** The following information is provided to guide users of samplers on the dangers and risks associated with entry into confined spaces.*

On April 15, 1993, OSHA's final ruling on CFR 1910.146, Permit Required Confined Spaces, became law. This new standard directly affects more than 250,000 industrial sites in the United States and was created to protect the health and safety of workers in confined spaces.

## Definition of Confined Space

A Confined Space is any location or enclosure that presents or has the immediate potential to present one or more of the following conditions:

- An atmosphere with less than 19.5% or greater than 23.5% oxygen and/or more than 10 ppm Hydrogen Sulfide (H<sub>2</sub>S)
- An atmosphere that may be flammable or explosive due to gases, vapors, mists, dusts, or fibers
- Toxic materials which upon contact or inhalation, could result in injury, impairment of health, or death

Confined spaces are not designed for human occupancy. They have restricted entry and contain known or potential hazards. Examples of confined spaces include manholes, stacks, pipes, vats, switch vaults, and other similar locations.

Standard safety procedures must always be followed prior to entry into confined spaces and/or locations where hazardous gases, vapors, mists, dusts, or fibers may be present. Before entering any confined space check with your employer for procedures related to confined space entry

Specifications are subject to change without notice.

General	
<b>Dimensions</b>	Width 61 cm (24 in.), Depth 61 cm (24 in.), Height 110 cm (43.5 in.), Weight 63.3 kg (140 lb)
<b>Cabinet</b>	Fiberglass reinforced plastic with beige UV inhibited polymer laminate.
<b>Temperature Range</b>	-29 to +50 °C (-20 to 122 °F); With optional controller compartment heater, -40 to +50 °C (-40 to 122 °F).
<b>Recovery Time</b>	With door open one minute in 24 °C (75 °F) ambient and 4 °C sample temperature, 5 minutes.
<b>Pull-Down Time</b>	From 24 °C (75 °F) to 4 °C (39 °F), 15 minutes.
<b>Thermal System</b>	Top mounted compressor/condenser with fan forced air cooled condenser; three-sided wrap-around evaporator plate; 2 in. rigid foam insulation; microprocessor controlled thermostat maintains sample liquid at 4 °C (±1 °C); frost free; compression gasket door seal; refrigeration components and plumbing are corrosion protected with conformal coating.
<b>Power Requirements</b>	115 V ac, 60 Hz (230 and 100 V ac optional); Compressor Running Amperage 1.5–2.0 A. Locked rotor current 12 amps. Installation Category II.
<b>Optional ac Power Backup (Pump Controller Only)</b>	Pump/Controller Only: Rechargeable 6 amp-hour gel lead acid battery takes over automatically with ac line power failure. Integral trickle charger maintains battery at full charge (factory installed option).
<b>Internal Battery</b>	Two C cell alkaline batteries; maintains program logic and real time clock for five years. Internal battery current draws less than 40 micro amps.
<b>Control Panel</b>	21 key membrane switch keypad with 4 multiple function soft keys; 8 line x 40 character alphanumeric, back lit liquid crystal graphics display. Self prompting/menu driven program.
<b>Data Logging</b>	Records program start time and date, stores up to 400 sample collection times/dates, all program entries, operational status including number of minutes or pulses to next sample, bottle number, number of samples collected, number remaining, sample identification number, and all logged data (i.e. level, flow, pH, stream temperature, refrigerated compartment sample temperature, ORP, rainfall, and any externally logged data - up to 7 external channels). Also, up to 200 events are logged, including alarm conditions, program run/stop events, etc.
<b>Set Point Sample Trigger</b>	When equipped with integral flow meter, pH/temperature/ORP meter, conductivity, and/or D.O. monitoring options, sampling can be triggered upon an upset condition when field selectable limits are exceeded. Concurrent with normal sampling routine, sample liquid is deposited in designated "trouble bottle(s)".
<b>Sampling Modes</b>	Multiple Bottle Time, Multiple Bottle Flow, Composite Multiple Bottle Time, Composite Multiple Bottle Flow, Composite Time, Composite Flow, Flow with Time Override, Variable Interval, Start/Stop, and Level Actuation.
<b>Program Delay</b>	Three formats: (1) 1-9,999 minutes or flow pulses in one unit increments (2) programmable sampler start time/date, and (3) programmable time/day of week.
<b>Overload Protection</b>	Controller: 5 amp dc line fuse. Compressor: Thermal overload relay opens at 110 °C (230 °F).
<b>Diagnostics</b>	Tests keypad, display, ROM, pump, liquid sensors, velocity signal, and distributor.
<b>Program Lock</b>	Access code protection precludes tampering.
Communications	
<b>EPROM Flash Memory</b>	Via RS232. Permits embedded software upgrades in the field.
<b>Serial Interface</b>	RS232 compatible; allows on-site collection of stored data.
<b>Modem (optional)</b>	14400, V.32 bis, V.42, MNP2-4 error correction. V.42 bis MNP5 data compression. MNP10-EC Cellular Protocol.
<b>Pager</b>	Alarm codes sent to up to three separate pagers' telephone numbers.

# Specifications

Sample Bottle Capacity	
<b>Single Bottle Mode</b>	6 gal polyethylene (with polypropylene cap)
<b>Multiple Bottle Mode</b>	Two Bottle Sampling: Set of two 2.5 gal glass (with Teflon®-lined lid) or 3 gal polyethylene bottle (with polypropylene cap)
	Four Bottle Sampling: Set of four 2.5 gal glass (with Teflon-lined lid) or 3 gal polyethylene bottles (with polypropylene cap)
	Eight Bottle Sampling: Set of eight 1.9 liter glass bottles (with Teflon-lined lid) or 2.3 L polyethylene bottles (with polypropylene cap)
	Twenty-four Bottle Sampling: Set of twenty-four 350 mL glass bottles (with Teflon-lined lid) or 1000 mL polyethylene bottles (with polypropylene cap)
Sampling Features	
<b>Multiple Programs</b>	Stores up to five separate sampling programs.
<b>Cascade</b>	Allows using two samplers in combination where the first sampler at the completion of the program initiates the second.
<b>Upset Sampling</b>	When equipped with integral flow meter, pH/temperature/ORP meter, conductivity, and/or D.O. monitoring options, sampling can be triggered upon an upset condition when field selectable limits are exceeded, concurrent with normal sampling routine, sample liquid is deposited in designated "trouble bottle(s)". Can also be triggered from an external trigger.
<b>Status Output</b>	Alerts operator to low main battery, low memory power, plugged intake, jammed distributor arm, sample collected, and purge failure.
<b>Automatic Shutdown</b>	Multiple Bottle Mode: After complete revolution of distributor arm (unless Continuous Mode selected). Composite Mode: After preset number of samples have been delivered to composite container, from 1–999 samples, or upon full container.
<b>Sample Volume</b>	Programmed in milliliters, in one mL increments from 10 to 9999 mL.
<b>Sample Volume Repeatability</b>	±5% typical
<b>Sampling Interval</b>	Time Proportional Sampling: Selectable in single increments from 1 to 9999 minutes in one minute increments. Flow Proportional Sampling: Continuous Volume, Variable Time (CVVT): 1 to 9999 "units" of flow volume, where "units" are whatever is set up for in the integral flow option or -1 to 9999 external-meter flow pulses: (momentary contact closure 25 msec. Or 5–12 V dc pulse; 4–20 mA interface optional) Flow Proportional Sampling: Constant Time, Variable Volume (CTVV): Format: 999: 00 hrs:min. Selectable in 1-minute increments of 1 to 59,940 minutes.
<b>Interval Between Samples</b>	Selectable in single increments form 1 to 9,999 flow pulses (momentary contact closure 25 msec. or 5–10 V dc pulse; 4–20 mA interface optional), or 1 to 9,999 minutes in one minute increments, or 1 to 9,999,999 "units" of volume, where "units" are whatever is set up for the integral flow option.
<b>Multiplex (Multiple Bottle Mode)</b>	Multiple Bottle Mode: Programming allows multiple samples per bottle and/or multiple bottles per sample collection.
Sample Pump and Strainer	
<b>Sample Pump</b>	High speed peristaltic, dual roller, with 3/8 in. ID by 5/8 in. OD medical grade silicone rubber pump tube.
<b>Pump Body</b>	Impact/corrosion resistant, glass reinforced Delrin®
<b>Vertical Lift</b>	27 ft maximum (Remote Pump Option recommended for lifts from 22 to 35 ft).
<b>Sample Transport Velocity</b>	2 fps minimum, at 15 ft vertical lift in a 3/8 in. ID intake tube.
<b>Pump Flow Rate</b>	60 mL/sec at 3 ft vertical lift in a 3/8 in. ID intake line.
<b>Liquid Sensor</b>	Non-wetted, non-contact, ultrasonic.

<b>Intake Purge</b>	Air purged automatically before and after each sample; duration automatically compensates for varying intake line lengths.
<b>Pump/Controller Housing</b>	High impact injection molded ABS; submersible, watertight, dust tight, corrosion & ice resistant; NEMA 4X,6.
<b>Internal Clock</b>	Indicates real time and date; 0.007% time base accuracy.
<b>Manual Sample</b>	Initiates a sample collection independent of program in progress.
<b>Intake Rinse</b>	Intake line automatically rinsed with source liquid prior to each sample, from 0 to 3 rinses.
<b>Intake Retries</b>	Sample collection cycle automatically repeated from 0 to 3 times if sample is not obtained on initial attempt.
<b>Intake Tubing</b>	¼ in. and ¾ in. ID vinyl or ¾ in. ID Teflon* lined polyethylene with protective outer cover.
<b>Intake Strainers</b>	Choice of Teflon® and 316 stainless construction, and all 316 stainless steel in standard size and low profile for shallow depth applications.

## Factory Installed Options

pH/Temperature/ORP Meter	
<b>Control/Logging</b>	Field selectable to log pH/temperature or ORP independent of sample operation or to control sample collection in response to volume exceeding low/high setpoints.
<b>pH/Temperature Sensor</b>	Temperature compensated; impact resistant ABS plastic body Combination electrode with porous Teflon junction
<b>Measurement Range</b>	0 to 14 pH, -10 to 105 °C
<b>Operating Temperature</b>	-18 to 80 °C (0 to 176 °F)
<b>Dimensions</b>	1.9 cm dia. × 15.2 cm long (0.75 in. × 6 in.) with 1.9 cm (0.75 in.) mpt cable end
Dissolved Oxygen Meter	
<b>Control/Logging</b>	Field selectable to log dissolved oxygen independent of sampler operation or to control sample collection in response to volume exceeding low/high setpoints.
<b>Measurement Method</b>	Galvanic
<b>Sensor</b>	Temperature compensated; impact resistant polypropylene body
<b>Measurement Range</b>	0 to 20 mg/L
<b>Resolution</b>	0.01 mg/L
<b>Accuracy</b>	±3% of reading or 0.1 mg/L
<b>Operating Temperature</b>	0 to 50 °C (32 to 122 °F)
<b>Dimensions</b>	1.7 mm diameter × 15.7 cm long (0.65 in. × 6.25 in.) with 1.9 cm (0.75 in.)
Conductivity Meter	
<b>Control/Logging</b>	Field selectable to log conductivity independent of sampler connection or to control sample collection in response to volume exceeding low/high setpoints.
<b>Sensor</b>	Temperature compensated; impact resistant polypropylene body
<b>Measurement Range</b>	0 to 20 mS/cm
<b>Resolution</b>	0.01 mS/cm or 1 mS/cm
<b>Accuracy</b>	±2% of reading or 0.01 mS
<b>Operating Temperature</b>	0 to 50 °C (32 to 122 °F)
<b>Dimensions</b>	1.7 cm diameter × 15.2 cm long (0.67 in. × 6 in.) with 1.9 cm (0.75 in.) mpt cable end

# Specifications

Rain Gauge Input	
<b>General Information</b>	For use with the Tipping Bucket Rain Gauge. The Sampler Program can be initiated upon field selectable rate of rain. Sampler records rainfall data. Each tip = 0.25 mm (0.01in.) of rain.
Analog Input Channels	
<b>General Information</b>	Up to 3 additional data logging channels record data from external source(s) Field assignable units -4.0 to +4.0 V dc and 0 to 20 mA
4–20 mA Output	
<b>General Information</b>	Up to 2 output signals available. User assignable
<b>Maximum Resistive Load</b>	600 ohms
<b>Output Voltage</b>	24 V dc—no load
<b>Insulation Voltage</b>	Between flow meter and 4–20 mA output—2500 V ac Between the two 4–20 mA outputs—1500 V ac
Alarm Relays	
<b>General Information</b>	(4) 10 amp/120 V ac or 5 amp/220 V ac form C relays ±0.1% FS Error User assignable for any internal or external data channel or event.
Downlook Ultrasonic Sensor 40 kHz	
<b>Accuracy</b>	0.003 m (±0.01 ft)
<b>Maximum Range</b>	3.35 m (11 ft) with a 3.05 m (10 ft) span
<b>Deadband</b>	38 cm (15 in.) maximum, self-minimizing
<b>Material</b>	PVC housing with Buna-N acoustic window
<b>Cable</b>	4 conductor with integral stainless steel support cable
Submerged Pressure Transducer	
<b>Material</b>	Epoxy body with stainless steel diaphragm.
<b>Cable</b>	Polyurethane sensor cable with air vent.
<b>Cable Length</b>	7.6 m (25 ft) standard; 76 m (250 ft) maximum
<b>Sensor Dimensions</b>	2 cm H x 3.8 cm W x 12.7 cm L (0.8 in. x 1.5 in. x 5 in.)
<b>Maximum Range</b>	5 psi, 0.063 to 3.5 mm (0.018 to 11.5 ft) 15 psi, 0.063 m to 10.5 m (0.018 to 34.6 ft)
<b>Maximum Allowable Level</b>	3x over pressure
<b>Operating Temperature Range</b>	0 to 71 °C (32 to 160 °F)
<b>Compensated Temperature Range</b>	0 to 30 °C (32 to 86 °F)
<b>Air Intake</b>	Atmospheric pressure reference is desiccant protected.

Submerged Area/Velocity Probe	
<b>Method</b>	Doppler Principle/Pressure Transducer.
<b>Material</b>	Polymer body, 316 series stainless steel diaphragm.
<b>Cable</b>	8-conductor urethane sensor cable with air vent.
<b>Cable Length</b>	7.6 m (25 ft) standard
<b>Sensor Dimension</b>	Length: 12.7 cm (5 in.) Width: 3.8 cm (1.5 in.) Height: 2 cm (0.8 in.)
<b>Velocity</b>	Velocity accuracy: 2% of reading; Zero Stability: <0.015 mps (<0.05 fps). Response time: 4.8 seconds. Profile Time: 4.8 seconds. Range: -1.52 to 6.1 mps (-5 to +20 fps). Resolution: 0.3 cm (0.01 fps).
<b>Depth</b>	Depth Accuracy: 0–3.35 m (0–11 ft) 1.37 mm ( $\pm 0.054$ in.) 0–10.06 m (0–33 ft) 4.09 mm ( $\pm 0.161$ in.)
	Maximum Allowable Level: 3x over pressure.
	Operating Temperature Range: 0 to 71 °C (32 to 160 °F).
	Compensated Temperature Range: 0 to 30 °C (32 to 86 °F).
	Temperature Error: 0.005 to 3.5 m $\pm 0.0022$ m/°C (0.018 to 11.5 ft $\pm 0.004$ ft/°F) 0.005 to 10.5 m $\pm 0.006$ m/°C (0.018 to 34.6 ft $\pm 0.012$ ft/°F) (maximum error w/in compensated temperature range - per degree of change)
	Velocity Induced Error on Depth (patent pending): 0 to 3.05 mps (0 to 10 fps) = 0.085% of reading.
Air Intake: Atmospheric pressure reference is desiccant protected.	





## 1.1 Controller Cover

The controller is mounted on top of a specially designed refrigerator. The sample line passes through the top of the refrigerator and into the refrigerated compartment where the sample container(s) are located. The compartment is surrounded by rigid foam insulation and utilizes a 120 CFM condenser fan. An optional controller cover locks and protects the controller from damage and unauthorized users.

Sample temperature is controlled by an adjustable air sensing thermostat maintaining samples at 4 °C (39 °F) in ambients up to 50 °C (120 °F). The unit has a magnetic door seal and does not require rear ventilation. The refrigerator interior is food grade plastic and the exterior is coated galvanized steel (304 stainless steel is optional). As a further barrier against corrosion, the refrigeration components and copper plumbing are treated with phenolic resin coating.

## 1.2 Front Panel

The front panel (Figure 1) of the sampler consists of the keypad, liquid crystal display, and the internal case humidity indicator.

Figure 1 Front Panel

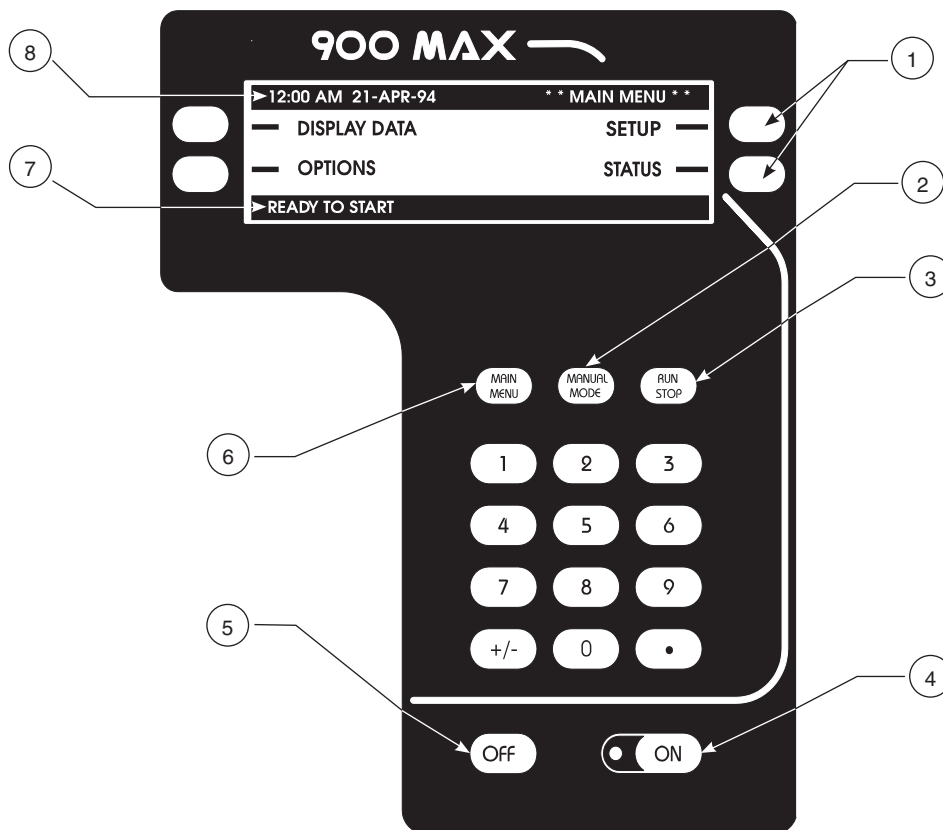

1. Soft Keys	5. Power OFF Key
2. Manual Mode Key	6. Main Menu Key
3. Run/Stop Key	7. Status Bar
4. Power ON Key	8. Menu Bar

# Section 1

## 1.2.1 Keypad Description

The keypad includes the numeric keypad, soft keys, and function keys.

### Numeric Keypad

The numeric keypad consists digits 0 through 9, a +/- key, and a decimal key.

### “Soft” Keys

Soft keys are blank, white keys located to the left and right of the display. If no function is shown for a specific key, that key is not currently active. The soft key labels appear on the display and indicates (with a straight line) the proper soft key to push for that action.

In some cases during a programming step an item from a list needs to be selected. The soft keys on the right side of the display will change to display **UP** and **DOWN** arrows. Scroll through the list of choices.

### Power ON/OFF Key

To turn the instrument on, press the **ON** key. When the instrument is turned on, a green light located next to the **ON** key flashes to indicate that the sampler power is turned on. To turn the instrument off, press the **OFF** key.

### Function Keys

Three white function keys ([Table 1](#)) are located just above the numeric keypad re used often while operating the sampler. These functions are dedicated keys to allow quick access.

**Table 1**Function Key Descriptions

Function Key	Description
<b>Main Menu</b>	This is the starting point to get to any other point in the program. Press the Main Menu key at any time during programming to return to the Main Menu Screen. The current action is cancelled if changes are not yet accepted.
<b>Manual Mode</b>	Manually controls the operation of the sample pump and the distributor arm. <b>ADVANCED DISTRIBUTOR</b> soft key: Moves the distributor arm to the user selected bottle. Used to verify the operation of the distributor or when repositioning the arm if it was moved by hand. <b>GRAB SAMPLE</b> soft key: Takes a sample in the same manner as when a program is running. Includes all pre-rinses and sample retries, if programmed. <b>PUMP OPERATION</b> soft key: Allows manual control of the pump in both forward and reverse directions. Once started, the pump is stopped by pressing any key.
<b>Run/Stop</b>	Runs (or resumes) a program and stops a currently running program.

## 1.2.2 Liquid Crystal Display

The liquid crystal display (LCD) works in conjunction with the four soft keys. When a soft key changes function, the display shows the new function.

### Menu Bar

The Menu Bar appears in a black band on the top edge of the display. The upper left corner of the menu bar shows the time and date. The upper right corner shows the name of the current menu ([Figure 1](#)).

### Status Bar

The Status Bar appears along the bottom edge of the display. The appearance of the status bar changes depending upon the function performed (Figure 1). The lower left corner of the Status Bar indicates whether a program is Complete, Running, Halted, or Ready To Start. If it is not needed during a programming step, it disappears.

The lower right corner displays system alarm conditions, such as low memory battery, jammed distributor etc. For a list of possible alarms refer to [section 6.4 on page 89](#). The status bar also lists the valid choices when entering certain programming information.

### 1.2.3 Internal Humidity Indicator

The round window of the internal case humidity indicator (Cat. No. 2660) turns pink when the internal case humidity exceeds 60 percent.

The sampler is equipped with an internal desiccant module (Cat. No. 8849) to absorb any humidity that may have been trapped in the case during final assembly. Under normal operating conditions, this desiccant provides long-term protection against condensed moisture inside the case.

Replacement of the internal desiccant module is only necessary if the indicator turns pink. (Refer to [section 7.10 on page 103](#) for details on replacing the internal desiccant.)

Figure 2 Humidity Indicator



## 1.3 Interface Connectors

Interface connectors are located on the left side of the controller housing. An optional weather tight terminal box located on the back of the sampler provides conduit termination for all input/output lines.

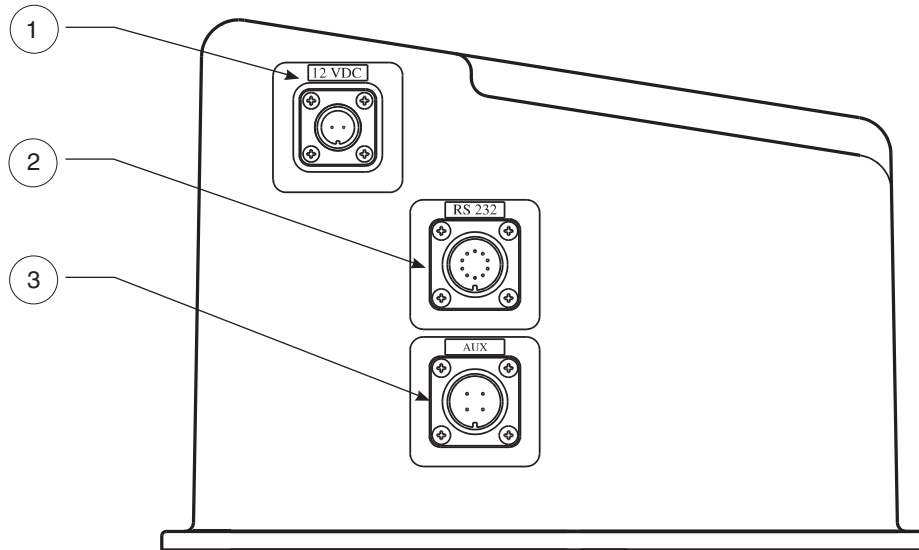

1. 12 V dc	2. RS232	3. Auxiliary
------------	----------	--------------

The sampler comes standard with two interface receptacles.

- 12 V dc (Power Input)
- Auxiliary (Multi-purpose input/output port)
- RS232 (Serial communications port)
- Thermal (Control port for heating and cooling system)

In addition, the sampler can be used with a wide variety of optional devices:

- Level and Flow Monitoring (Sensors)      Three additional analog inputs of 4–20 mA or -4.0 V dc to +4.0 V dc
- pH/ORP      • 4–20 mA Current Loop Output
- Conductivity      • Modem
- Dissolved Oxygen      • Rain Gauge
- Temperature

### 1.3.1 Receptacle Caps

Interface receptacles are covered with push-on receptacle caps. These caps protect the connector pins from dirt and moisture and should be attached to any receptacle not in use.

## 1.4 Principle of Operation

### 1.4.1 Liquid Sensing

The sampler is designed for indoor, permanent installation. All controls are located on the front panel. Capped, watertight connectors for interfacing to external devices are located along the left side of the controller.

The sampler uses a liquid sensing system to detect the absence or presence of liquid at the peristaltic pump intake. The liquid sensor ([Figure 3](#)) is located on the front of the control housing.

The liquid sensing system provides three primary benefits:

- Accurate, repeatable sample volumes
- Intake tube prerinse
- Sample retry

**Figure 3**      **Liquid Sensor**

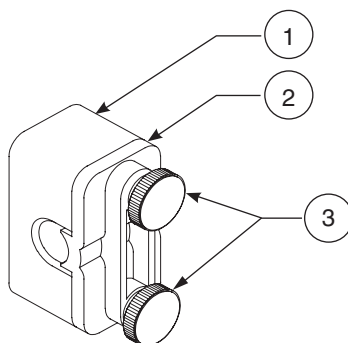

1. Sensor Body	2. Sensor Cover	3. Knobs (turn to remove)
----------------	-----------------	---------------------------

#### **Accurate, Repeatable Sample Volumes**

The liquid sensor detects the presence and velocity of the incoming sample. This information allows the sampler to automatically dispense the correct amount of liquid into the sample bottle.

The liquid sensing system allows the sampler to deliver repeatable sample volumes even with changing suction lifts. Each time the peristaltic pump pulls a sample, the microprocessor determines the time required for liquid to travel to the liquid sensor. If the suction lift increases due to a drop in level at the sample source, the time required for liquid to reach the sensor will increase. The microprocessor automatically compensates for this change by allowing the peristaltic pump to deliver sample liquid for a corresponding longer period of time. Conversely, if suction lift decreases due to an increase in level at the sample source, the time required for liquid to the sensor will decrease. Again, the microprocessor automatically compensates for this change by decreasing the sample delivery time.

### **Intake Tube Pre-Rinse**

The liquid sensor also rinses the intake tubing with the liquid from the sample source before taking each sample.

Upon sample initiation, the pump purges the intake line. The pump then reverses, pulling liquid through the tubing, until it reaches the liquid sensor. When the sensor detects liquid, the pump purges back to the source, and then draws a sample. After the desired sample is collected, the pump purges the intake line and awaits the next sample cycle. The sampler can be programmed for up to 3 rinses before each sample.

### **Sample Retry**

The liquid sensing system permits the sampler to repeat a collection cycle if a sample is not obtained during the regular cycle.

The intake line length is user-programmed into the sampler memory. For a line length of 3 to 99 feet, the sampler has a built-in “look up” table that detects the maximum time required for liquid to reach the sensor. If liquid does not reach the sensor within the defined time period, the pump will automatically purge the intake line and initiate another sample cycle. The sampler may be programmed for up to three repeated attempts. If a sample is not obtained, the sampler retains in memory the time, date and reason for the missed sample.



# INSTALLATION

## **DANGER**

*Some of the following manual sections contain information in the form of warnings, cautions and notes that require special attention. Read and follow these instructions carefully to avoid personal injury and damage to the instrument. Only personnel qualified to do so, should conduct the installation/maintenance tasks described in this portion of the manual.*

## **DANGER**

*Certains des chapitres suivants de ce mode d'emploi contiennent des informations sous la forme d'avertissements, messages de prudence et notes qui demandent une attention particulière. Lire et suivre ces instructions attentivement pour éviter les risques de blessures des personnes et de détérioration de l'appareil. Les tâches d'installation et d'entretien décrites dans cette partie du mode d'emploi doivent être seulement effectuées par le personnel qualifié pour le faire.*

## **PELIGRO**

*Algunos de los capítulos del manual que presentamos contienen información muy importante en forma de alertas, notas y precauciones a tomar. Lea y siga cuidadosamente estas instrucciones a fin de evitar accidentes personales y daños al instrumento. Las tareas de instalación y mantenimiento descritas en la presente sección deberán ser efectuadas únicamente por personas debidamente cualificadas.*

## **GEFAHR**

*Einige der folgenden Abschnitte dieses Handbuchs enthalten Informationen in Form von Warnungen, Vorsichtsmaßnahmen oder Anmerkungen, die besonders beachtet werden müssen. Lesen und befolgen Sie diese Instruktionen aufmerksam, um Verletzungen von Personen oder Schäden am Gerät zu vermeiden. In diesem Abschnitt beschriebene Installations- und Wartungsaufgaben dürfen nur von qualifiziertem Personal durchgeführt werden.*

## **PERICOLO**

*Alcune parti di questo manuale contengono informazioni sotto forma d'avvertimenti, di precauzioni e di osservazioni le quali richiedono una particolare attenzione. La preghiamo di leggere attentivamente e di rispettare quelle istruzioni per evitare ogni ferita corporale e danneggiamento della macchina. Solo gli operatori qualificati per l'uso di questa macchina sono autorizzati ad effettuare le operazioni di manutenzione descritte in questa parte del manuale.*





**DANGER**

*This instrument should be installed by qualified technical personnel to ensure adherence to all applicable electrical codes.*

**DANGER**

*Cet appareil doit être installé par du personnel technique qualifié, afin d'assurer le respect de toutes les normes applicables d'électricité.*

## 2.1 Unpacking the Instrument

Remove the sampler from the shipping carton and inspect it for any damage. Contact Hach Customer Service at 1-800-227-4224 if any items are missing or damaged.

## 2.2 Selecting the Installation Site

**DANGER**

*This product is not designed for hazardous locations where combustible environments may exist.*

**DANGER**

*Ce produit n'est pas conçu pour des endroits dangereux dans lesquels il peut exister des environnements combustibles.*

See [Figure 4](#) and follow the simple guidelines below to allow complete drainage of the intake line and prevent cross-contamination between samples.

- Install the sampler as close to the sample source as site conditions permit. This will increase pump tube life and optimize overall sampler performance.
- Install the sampler above the sample source, with the intake tubing sloping downward to the sample.
- Make sure that the intake tubing is free of kinks or loops.

**Figure 4**      **Setting Up the Instrument**

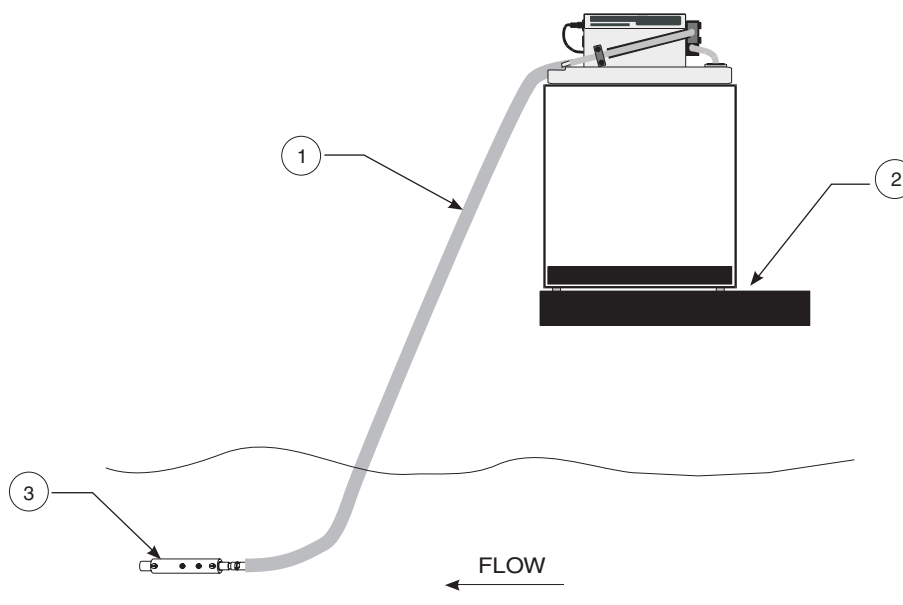

<p><b>1.</b> Slope tubing down to source (no loops, kinks, or excessive tubing)</p>	<p><b>2.</b> Place sampler on a level surface.</p>	<p><b>3.</b> Locate strainer in an area of turbulent and well mixed flow.</p>
---	--	---

### 2.3 Installing the Pump Tube in the Sensor Body

**Note:** Do not stretch the tubing in the sensor body, as this could affect the ability of the sensor to detect liquid through the pump tubing.

**Note:** Use the proper length of silicone tubing in the pump body. An improper length can reduce the life of the tubing and pump rollers. Refer to [Figure 5](#) for the correct length.

1. Remove the four screws on the pump cover ([Figure 5](#)).
2. Remove the front cover of the pump housing. Remove the tubing. Locate the black dots on the tubing. The end of the tube that extends farthest beyond the black dot attaches to the stainless steel tubing connector.
3. Install the pump tube in the pump housing so the black dots are visible just outside the pump body.
4. After inserting the new pump tube as shown, reinstall the front cover and secure it with the four screws until finger tight.
5. Make sure that the tubing extends through the liquid sensor and out of the controller as shown in [Figure 6](#).

**Figure 5 Pump Tube Loading**

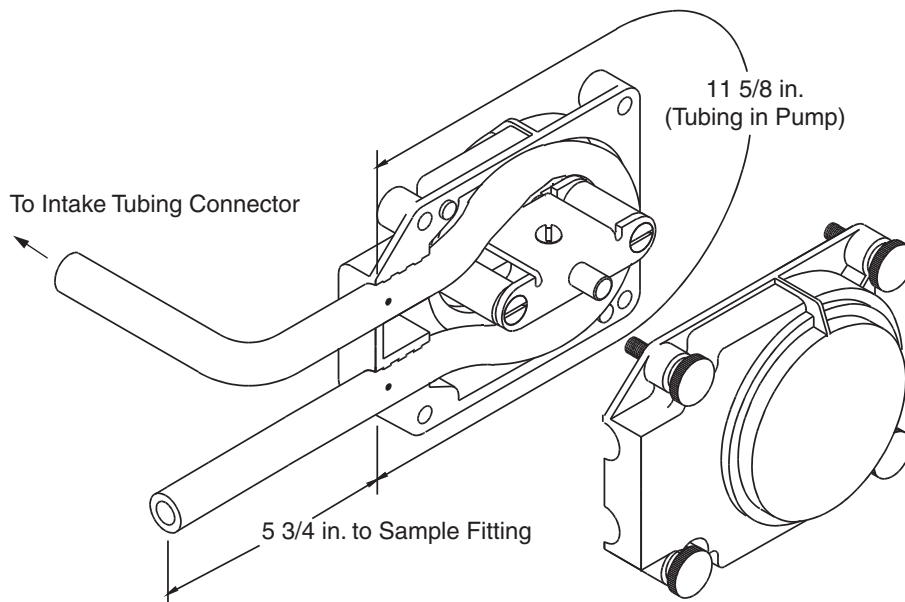

**Figure 6 Installing Pump Tube Through the Sensor Body**

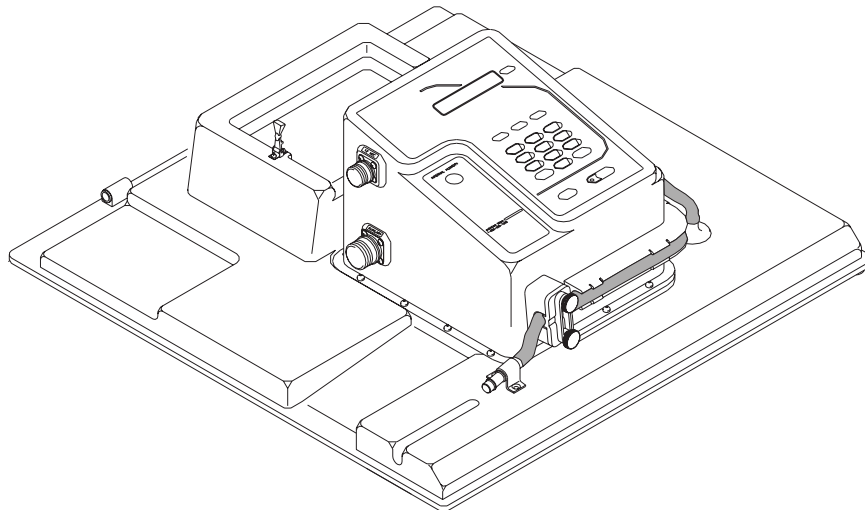

## 2.3.1 Attaching the Intake Line

### 2.3.1.1 Attaching the Vinyl Tubing

The connection kit (Cat. No. 2248) contains two identical assemblies, one for connecting vinyl tubing to the tubing attached to the sampler, and the other for connecting the vinyl tubing to an intake strainer or remote pump. The kit contains four hose clamps and two stainless-steel tubing connectors.

1. Push one end of the tubing connector into the vinyl tubing attached to the controller until the tubing abuts the shoulder of the tubing connector. Secure with a tubing clamp (Figure 7).
2. Push the other end of the tubing connector into the vinyl tubing until the tubing abuts the shoulder of the tubing connector and secure with a tubing clamp (Figure 7).
3. Repeat Step 1 and Step 2 for the fitting that connects the vinyl tubing to an intake strainer or a remote pump.

**Figure 7** 3/8" Vinyl Tubing Connector

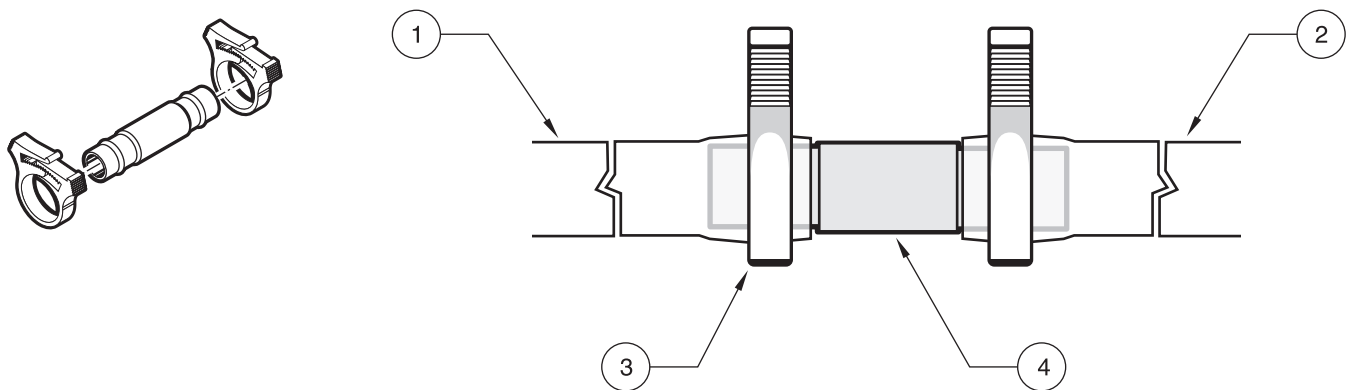

1. Vinyl tubing to controller	3. Tubing clamp (2 required)
2. Vinyl tubing to strainer or pump.	4. Stainless-steel tubing connector

### 2.3.1.2 Attaching the Teflon®-Lined Tubing

The Connection Kit for Teflon-lined Tubing (Cat. No. 2186) contains two identical assemblies, one for connecting the Teflon-lined tubing to the stainless steel tubing connector and the other for connecting the Teflon-lined tubing to the intake strainer. The kit contains six clamps, two lengths of silicone tubing, and two stainless-steel barbed fittings.

To connect the Teflon-lined tubing follow the instructions and Figure 8 below:

1. Place the Teflon-lined tubing over the tubing connector nipple until it abuts the shoulder of the tubing connector and secure with a tubing clamp.
2. Place one end of the silicone tubing over the wide end of the tubing connector and secure with a tubing clamp.
3. Slide a second tubing clamp over the other end of the silicone tubing. Push the silicone tubing over the stainless-steel fitting on the intake strainer and tighten the tubing clamp.

- Repeat the procedure for the fitting that connects the Teflon-lined tubing to the silicone pump tubing.

**Figure 8** 3/8" ID Teflon-lined Tubing Attached to Intake Strainer and Tubing Connector

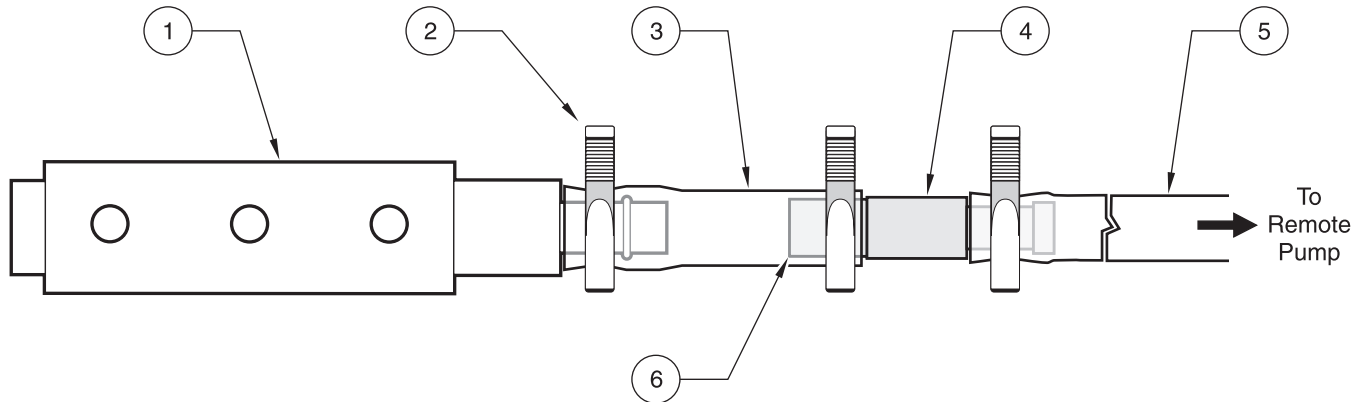

1. Intake strainer	4. Stainless-steel tubing connector
2. Tubing clamp (3 required)	5. Teflon-lined intake tubing
3. Two-inch piece of silicone tubing	6. Wide end of stainless steel tubing connector

### 2.3.2 Setting Up the Intake Line and Strainer

**Note:** If site conditions do not permit the intake to slope downward from the sampler to the sample source, disable the liquid sensors by calibrating the sample volume using the Timed Calibrate method when programming the sampler.

**Note:** Vertical lift should not exceed 27 ft. If the site requires more lift, you may purchase the Remote Pump Option. The remote pump option is factory installed. Any remote pump installed outside the factory will void the warranty.

For each sampling location, the intake line should be as short as practical, and be free of any sharp bends, coils, or loops. Install the intake line with a downward slope from the sampler to the sample source because:

- This will ensure the complete drainage of the intake line when it is air-purged before and after each sample, and will help to prevent cross-contamination of the individual samples.
- Complete drainage is important in freezing conditions, as any liquid slugs that remain could freeze and plug the line and possibly damage the sampler.

Place the sample intake and strainer in the mainstream of the sampling source, in an area of turbulent and well mixed flow.

Also, you must account for the vertical location of the intake. A position too near the surface may yield excess lighter materials, while a position too near the bottom may yield excess heavy materials. The constituents of interest must be considered when positioning the intake strainer.

## 2.4 Choosing Bottle and Retainer Configurations

A broad range of bottle configurations are available for the Sigma 900 MAX Refrigerated Sampler.

Figure 9 Bottle Configurations

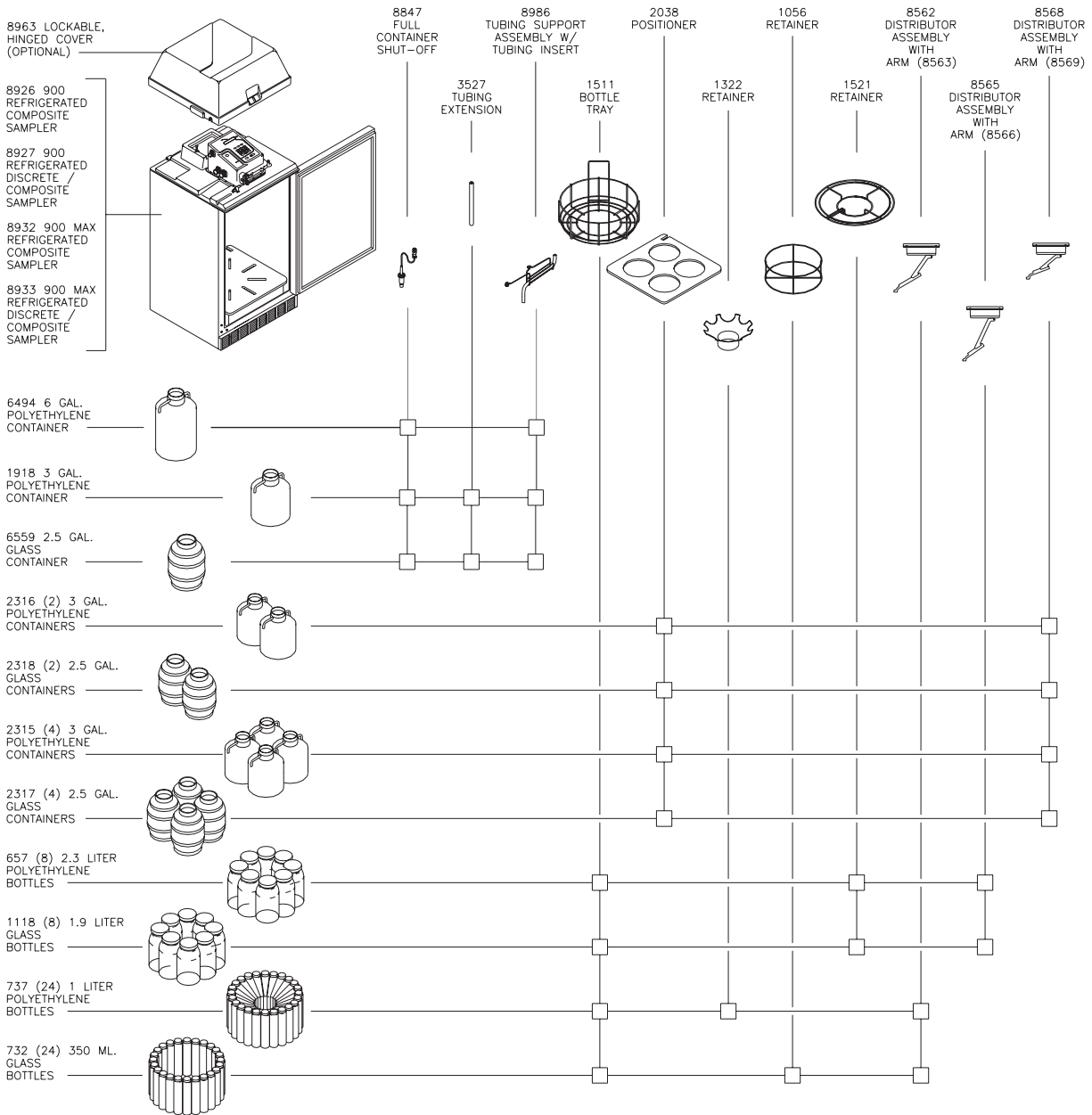

## 2.5 Setting Up the Bottles

### 2.5.1 One-Bottle Sampling

For single bottle composite sampling, install the Full Bottle Shut-off (refer to Section 2.7 on page 31) and place the bottle in the center of the refrigerator (Figure 15 on page 31). The Full Bottle Shut-off positions the sample tubing over the bottle mouth.

### 2.5.2 Two- and Four-bottle Sampling

For two-bottle sampling, install the distributor (refer to Section 2.6.1 on page 30) and place the bottles in the Bottle #1 and Bottle #2 positions in the tray as shown in Figure 10.

## Section 2

For four-bottle sampling, install the distributor and place all four bottles in the tray as shown in [Figure 11](#).

**Figure 10** Two-bottle Locations

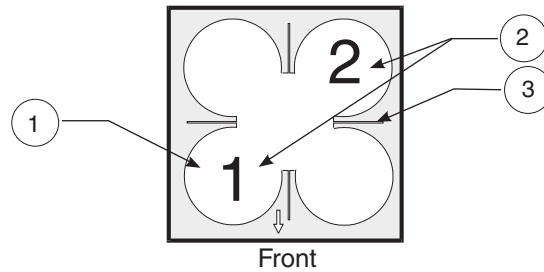

1. Single Bottle Location	2. Two Bottle Location	3. Slots for Wire From Bottle Tray (8 or 24 bottle)
---------------------------	------------------------	---

**Figure 11** Four-bottle Locations

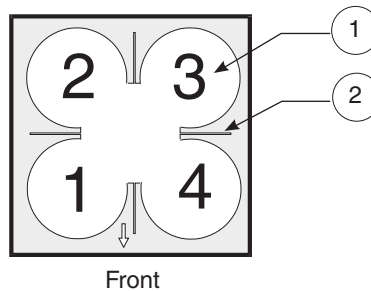

1. 1, 2, or 4 Bottle Locations	2. Slot for Wire From Bottle Tray (8 or 24 bottles)
--------------------------------	---

### 2.5.3 Eight-, 12-, or 24-bottle Sampling

For eight-, 12- or 24-bottle sets, install the distributor (refer to [section 2.6.1 on page 30](#)). Place the bottles in the tray and install the proper bottle retainer ([Figure 12](#)).

Bottle #1 is the first bottle clockwise (looking down on the tray) from the right side of the tray. Bottle #1 is located on the inside of each bottle tray for all multiple bottle sets ([Figure 12](#)).

Figure 12 Eight-, 12-, or 24-bottle Configuration

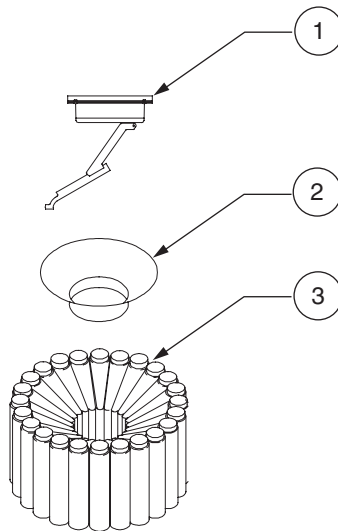

1. Distributor	2. Retainer	3. Bottles and Bottle Tray
----------------	-------------	----------------------------

## 2.6 Installing the Distributor (Multiple Bottle Operation)

**Note:** Make sure the sampler is powered off before removing or installing the distributor.

For multiple bottle sampling, a motorized arm (Distributor) is provided to automatically position the sample tube over the proper bottle. The microprocessor-controlled distributor arm can automatically locate two, four, eight, 12, or 24 discrete bottles.

To install the distributor:

1. Locate the two slots along one edge of the distributor assembly base plate (Figure 14). Slide the distributor assembly, slots first, under the shoulder screws located on the top inside surface of the controller section.
2. When fully seated, hand tighten the knurled thumbscrew to hold the distributor in place.
3. To ensure the arm has sufficient freedom of movement, hand-rotate the arm to the opposite end of the Arm Stop.
4. Install the silicone distributor tubing to the sample fitting on the top underside surface of the controller housing.

**Note:** Use care not to force the arm past the Arm Stop clip. The Arm Stop keeps the arm from being rotated more than 360 degrees and keeps the distributor tubing from kinking.

The distributor tubing should be installed so that the end of the tubing extends out of the nozzle end of the distributor arm no more than 1/8 in. (Figure 13). Do not let the tubing extend more than 1/8 in. past the nozzle end of the arm.

## Section 2

### 2.6.1 Distributor Arm Alignment

1. Program the sampler for 24-bottle operation.
2. Press **START PROGRAM** to set the distributor shaft to the Bottle #1 position.
3. Place the arm on the distributor shaft and align the rib on the inside wall of the control housing skirt.
4. Secure the arm to the shaft by tightening the 1/8 in. hex-head screw, located on the distributor arm.

**Figure 13** Distributor Tubing in Arm

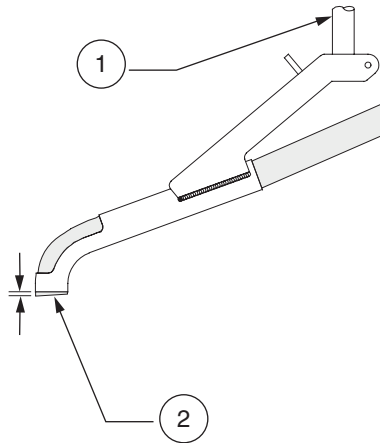

1. Distributor Shaft	2. Nozzle End (1/8 in. max)
----------------------	-----------------------------

**Figure 14** Distributor Installation

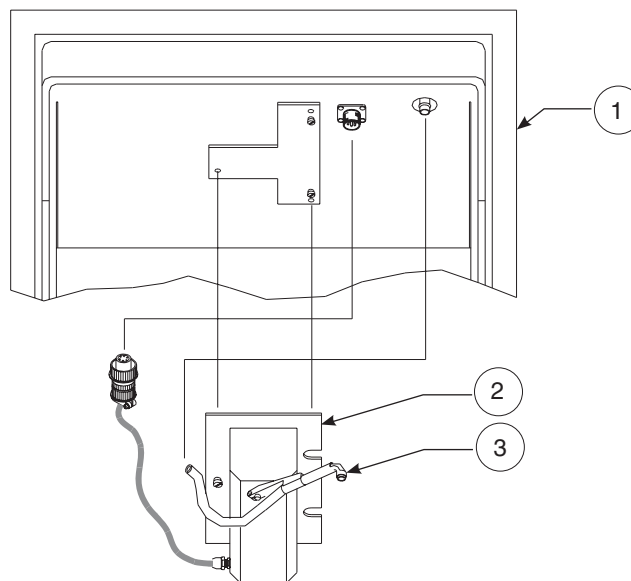

1. Refrigerator	2. Distributor Assembly	3. Distributor Arm
-----------------	-------------------------	--------------------



## 2.7 Installing the Full-Bottle Shut-Off Device (Single Bottle Operation)

1. Install the rubber grommet into the hole provided in the cap of the composite bottle.
2. Slide the Full Bottle Shut-Off, float first, into the bottle through the center of the grommet.
3. Insert the Full Bottle Shut-Off connector into the receptacle (Figure 15) and securely tighten.

Figure 15 Full Bottle Shut-off Installation

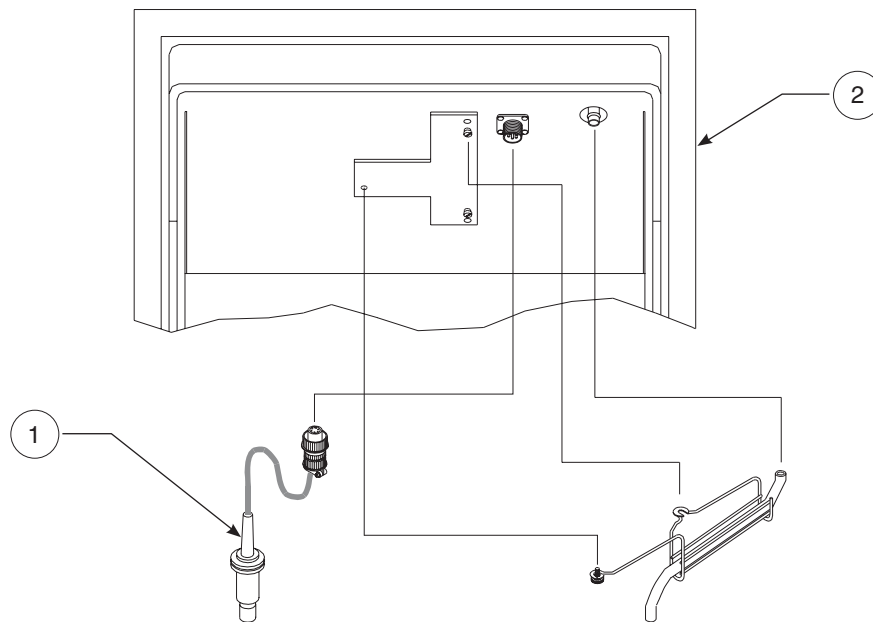

1. Full Bottle Shut-off	2. Refrigerator
-------------------------	-----------------

## 2.8 Power Connections

**Note:** Install the sampler on its own circuit to ensure a continuous, stable source of power.

Use the ac power cords to apply ac power to the controller and the refrigerator.

The sampler controller operates on a 12 V dc which is supplied by a built-in ac/dc power converter. The power supply is permanently sealed in the compartment located behind the transition plate. An ac line fuse is located on the left side of the controller.

An optional power backup assembly is located on top of the ac power supply. The ac power backup is designed to power the pump and controller only. Pull the rubber hold-downs up and over the clips at each end of the ac Power Backup to hold it in place.

The short, 2-pin cable on the power supply (or battery) connects to the controller receptacle labeled 12 V dc.

**Important:** Whenever electricity is present, there is a possibility of electrical shock. Before connecting the sampler to an ac power source, the following safety precautions should be taken:

- Check the power source to make sure that it satisfies the ac power requirements of the sampler.
- Make sure that all electrical installations and connections are in accordance with national and local electrical codes.
- Before performing any maintenance, disconnect the sampler from the power source.
- Do not attempt to make any connection or otherwise handle the electrical components of the sampler when connected to ac line power if the immediate area is wet, or if hands or clothing are wet.
- If the circuit breaker or fuse in the ac power source is tripped, determine the cause before restoring power to the sampler.
- Make sure the power circuit is grounded and protected with a Ground Fault Interrupter (GFI).

### 2.9 Auxiliary Receptacle Pin Identification

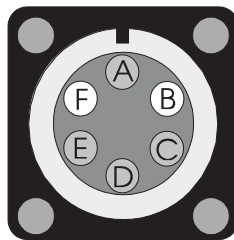

<b>Pin A/White (12 V dc)</b>	Powers an external device or flow meter. Must be used in conjunction with Pin B (ground).
<b>Pin B/Blue (Ground)</b>	Connected to dc ground and is isolated from the earth ground found in the ac power line.
<b>Pin C/Yellow (Pulse Input)</b>	With the sampler in Flow Proportional mode and connected to an external flow meter, a 5 to 12 V dc input pulse lasting at least 25 milliseconds will cause the sampler to decrement one count. The 12 V dc line found on Pin A can be used directly with a simple contact closure to Pin C or an external 5 to 12 V dc pulse may be applied providing the ground side of the external signal is connected to the sampler ground at Pin B. This count is actuated at the beginning of the input signal (the leading edge of the pulse).
<b>Pin D/Black (Liquid Level Actuator/ Auxiliary Control Input)</b>	This line is held at 5 V dc inside the sampler. When shorted to ground (Pin B), a signal is sent to the microprocessor inside the sampler causing it to “wake up” and begin or resume its sampling program. It can be used in conjunction with a simple level float to actuate the sampler when liquid is present or to take over after a second sampler has finished its program. It may also be used with any device (such as a pH meter) that produces a dry contact output to control the sampler in response to some user-defined condition (i.e. high or low pH); must be used in conjunction with Pin B.
<b>Pin E/Red (Special Output)</b>	Normally at 0 V dc, this line goes to 12 V dc upon any of the selected events described in.
<b>Pin F/Green (Program Complete Output)</b>	Normally an open circuit, this line switches to ground for 90 seconds at the conclusion of the sampling program. Used to “wake up” another sampler to take over sampling or to signal an operator or data logger upon the completion of the sampling program. This pin is also used to signal the bottle full condition in a single bottle/continuous mode, and will transmit the bottle # to an 950 Flow Meter if the program complete signal is disabled.

### 2.9.1 Splitter Interface

Use the Splitter Interface (Cat. No. 939) when more than one signal is needed simultaneously. Connecting the interface to the 6-pin connector on the sampler provides three additional connectors. Two or more interfaces may be connected in series to allow for additional connections.

**Figure 16** Splitter Interface

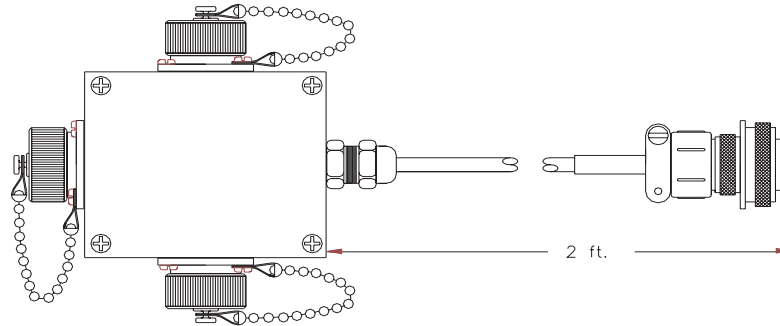





## OPERATION

### **DANGER**

*Handling chemical samples, standards, and reagents can be dangerous. Review the necessary Material Safety Data Sheets and become familiar with all safety procedures before handling any chemicals.*

### **DANGER**

*La manipulation des échantillons chimiques, étalons et réactifs peut être dangereuse. Lire les Fiches de Données de Sécurité des Produits (FDSP) et se familiariser avec toutes les procédures de sécurité avant de manipuler tous les produits chimiques.*

### **PELIGRO**

*La manipulación de muestras químicas, estándares y reactivos puede ser peligrosa. Revise las fichas de seguridad de materiales y familiarícese con los procedimientos de seguridad antes de manipular productos químicos.*

### **GEFAHR**

*Das Arbeiten mit chemischen Proben, Standards und Reagenzien ist mit Gefahren verbunden. Es wird dem Benutzer dieser Produkte empfohlen, sich vor der Arbeit mit sicheren Verfahrensweisen und dem richtigen Gebrauch der Chemikalien vertraut zu machen und alle entsprechenden Material Sicherheitsdatenblätter aufmerksam zu lesen.*

### **PERICOLO**

*La manipolazione di campioni, standard e reattivi chimici può essere pericolosa. La preghiamo di prendere conoscenza delle Schede Tecniche necessarie legate alla Sicurezza dei Materiali e di abituarsi con tutte le procedure di sicurezza prima di manipolare ogni prodotto chimico.*



### 3.1 Initial Power-Up of Sampler

After pressing the ON key, the sampler performs a complete diagnostic test and displays the menu shown when the unit was last turned off. Set the instrument programming features when the Main Menu is displayed. The Main Menu is the starting point for all programming operations. The Main Menu offers four choices:

- Setup—Basic and Advanced Sampling programming
- Status—Lists all current sampling status, power supply voltage, and values of any data channels that are enabled.
- Display Data—Shows graphs and tables of logged data ([Displaying Data on page 113](#))
- Options—Optional Device Programming

Setup and Option functions lead to sub-menus and will configure the basic and advanced features of the sampler. Refer to the [Quick Start Guides on page 105](#). The Display Data and Status Menus lead to sub-menus and will provide information only. Press **STATUS** to display any data channels that have enabled logging (flow, pH, temp., etc.)

11:00 AM 21 - APR - 01		* MAIN MENU*	
DISPLAY DATA		SETUP	
OPTIONS		STATUS	
READY TO START			

### 3.2 Basic Programming Setup

Basic programming setup must be performed, step-by-step and in its entirety, after the instrument is installed. Refer to the [Quick Start Guides on page 105](#) for more information. The basic program setup will modify the following items:

- Bottles
- Program Lock
- Sample Collection
- Liquid Sensor
- Intake Rinses
- Site ID
- Intake Tubing
- Program Delay
- Sample Distribution
- Sample Volume
- Sample Retries

In addition, several advanced sampling features are found on a sub-menu called Advanced Sampling. Refer to [section 3.3 on page 49](#) for Advanced Sampling Basic Programming Setup.

## Section 3

To make changes to the program entries after the basic programming setup, press **MAIN MENU** and select **SETUP>MODIFY SELECTED ITEMS** and highlight the program entry using the **UP** and **DOWN** keys.

To review all information in the Setup and Option menus without worrying about accidentally changing the information, use the Review All Items function to verify that the program is properly set up. For more information on this function refer to [Review All Items on page 113](#).

1. Press **SETUP** from the Main Menu to prepare the instrument for use.

11:00 AM 21 - APR - 01		* MAIN MENU*
DISPLAY DATA		SETUP
OPTIONS		STATUS
READY TO START		

2. From the Main Menu select **SETUP>MODIFY ALL ITEMS**.

11:00 AM 21 - APR - 01		* MAIN MENU*
		MODIFY ALL ITEMS
REVIEW ALL ITEMS		MODIFY SELECTED ITEMS
READY TO START		

3. Press **ACCEPT** to begin setting up the bottles.

### Step 1 - Bottles

- 1-A. Enter the total number of sample bottles in the refrigeration compartment, using the numeric keypad.

11:00 AM 21 - APR - 01		BOTTLES
ACCEPT	NUMBER OF BOTTLES:	
	—	
BACKUP		CLEAR ENTRY
ENTER: 1, 2, 4, 8, 12, OR 24		

*Note: The bottles may be installed directly in the refrigeration compartment or in the removable bottle tray when using sets greater than four bottles.*

- 1-B. Press **ACCEPT** to continue and move to the Bottle Volume menu.



- 1-C. Enter the bottle volume using the numeric keypad and select gallons or milliliters using the **CHANGE UNITS** key.

11:00 AM 21 - APR - 01		BOTTLES
ACCEPT	BOTTLE VOLUME	CHANGE UNITS
	— —	
BACKUP		CLEAR ENTRY
ENTER: 0.500—99.90		

- 1-D. Press **ACCEPT** and continue to Intake Tubing.

## Step 2 - Intake Tubing

11:00 AM 21 - APR - 01		INTAKE TUBING
ACCEPT	INTAKE TUBE LENGTH:	CHANGE UNITS
	—	
BACKUP		CLEAR ENTRY
ENTER: 3—99		

- 2-A. Enter the intake tube length attached to the sampler, using the numeric keypad. Length values from 100 to 3000 cm (3 to 99 ft) are valid. Change the measurement unit using the **CHANGE UNITS** key.

**Note:** Intake tube length affects sample volume accuracy, cut the tubing to the nearest whole foot. Avoid excessively long tubing runs. Doubling the intake tubing length can quadruple the pump tubing wear if intake rinses or sample retries are enabled. Always locate the sampler close to the sample liquid source to minimize tubing, pump, motor, and gearbox maintenance.

- 2-B. Press **ACCEPT** to move to the Intake Tube Type menu.
- 2-C. Select the type of intake tube ( $\frac{3}{8}$  in. Vinyl,  $\frac{1}{4}$  in. Vinyl,  $\frac{3}{8}$  in. Teflon®) using the **CHANGE UNITS** key.
- 2-D. Press **ACCEPT** to select the intake tube type and continue with Program Lock.

## Step 3 - Program Lock

**Note:** The program lock password is configured at the factory as “9000” and cannot be changed.

Enabling the Program Lock will provide a protective “password” which will keep unauthorized personnel from tampering with the instrument keypad.

- 3-A. Enable or Disable Program Lock using the **CHANGE CHOICE** key.

**Note:** When program lock is enabled and a user attempts to make a change in the program, a screen will ask the operator to enter the password. The operator must enter 9000 and press **ACCEPT**.

- 3-B. Press **ACCEPT** to continue the basic program setup and continue with Program Delay.

### Step 4 - Program Delay

*Note: If both Setpoint Sampling and Program Delay are enabled, the program delay is evaluated first, prior to any checking for setpoint conditions.*

- 4-A. Enable or Disable Program Delay using the **CHANGE CHOICE** key. Enabling the Program Delay will cause the sampling program to delay starting until a user specified time and day of week are programmed.
- 4-B. After enabling the program delay, enter the time and day of week that the program will begin. Use the soft keys to change the day of week as well as the AM/PM indicator.

11:00 AM 21 - APR - 01		PROGRAM DELAY
ACCEPT	START PROGRAM: 00:00 AM MON	CHANGE AM/PM
CLEAR ENTRY		CLEAR DAY
(USE THE NUMERIC KEYPAD)		

- 4-C. Press **ACCEPT** to continue with Sample Collection.

### Step 5 - Sample Collection

- 5-A. Select the type of sample collection; Time Proportional, Flow- Proportional Constant Volume, Variable Time (CVVT), or Flow-Proportional Constant Time, Variable Volume (CTVV).

11:00 AM 21 - APR - 01		SAMPLE COLLECTION
ACCEPT	SAMPLE COLLECTION	CHANGE CHOICE
BACKUP		
CHOICES: TIMED, FLOW PROPORTIONAL		

#### Timed-Proportional Sampling Intervals

When the program starts, a sample is taken immediately or delayed until after the first interval has elapsed. Select either, Take First Sample Immediately or After the First Interval.

Timed-Proportional samples are taken each time a user defined time interval has elapsed. Samples can be continually taken at that interval until the completion of the program.

- a. From the Sample Collection menu, press **CHANGE CHOICE** until Timed Proportional is displayed. Press **ACCEPT** to continue.

11:00 AM 21 - APR - 01		SAMPLE COLLECTION
ACCEPT	SAMPLE COLLECTION TIMED PROPORTIONAL	CHANGE CHOICE
BACKUP		
CHOICES: TIMED, FLOW PROPORTIONAL		

b. Enter the Interval Between Samples. Press **ACCEPT** to continue.

11:00 AM 21 - APR - 01		SAMPLE COLLECTION
<b>ACCEPT</b>	INTERVAL:	
<b>CANCEL</b>	00:00 (hrs:min)	<b>CLEAR ENTRY</b>
<b>ENTER: 000:01—999.00 (hrs:min)</b>		

c. Select either Take First Sample Immediately or After The First Interval?

*Note: When the program is started, the first sample is taken immediately upon pressing the start button or after the first interval has elapsed.*

11:00 AM 21 - APR - 01		SAMPLE COLLECTION
<b>ACCEPT</b>	TAKE FIRST SAMPLE:	<b>CHANGE CHOICE</b>
<b>CANCEL</b>	_____	
<b>CHOICES: IMMEDIATE, AFTER 1<sup>st</sup> SAMPLE</b>		

d. Press **ACCEPT** to continue to Sample Distribution.

**Flow Proportional Constant Volume, Variable Time (CVVT)**

CVVT sampling is a flow-proportional method of sampling. CVVT samples are taken when a user-defined flow volume occurs in the flow stream. This occurs when the sampler is programmed to take a sample every time a specified volume of flow occurs in the flow stream. Specified flow volume intervals can vary with the flow rate of the stream, therefore varied time intervals can occur when constant (fixed) volume occurs.

Flow volume is determined internally, by the optional integral flow meter or by an external flow meter.

a. Press **CHANGE CHOICE** until Flow Proportional is displayed. Press **ACCEPT**.

11:00 AM 21 - APR - 01		SAMPLE COLLECTION
<b>ACCEPT</b>	SAMPLE COLLECTION: FLOW-PROPORTIONAL	<b>CHANGE UNITS</b>
<b>CANCEL</b>		
<b>ENTER: 1.00 - 99999999</b>		

b. In the Flow Proportional menu, press **CHANGE CHOICE** until Constant Volume, Variable Time is displayed. Press **ACCEPT**.

11:00 AM 21 - APR - 01		FLOW PACING
<b>ACCEPT</b>	FLOW PACING MODE: CONST VOL / VAR TIME	<b>CHANGE CHOICE</b>
<b>CANCEL</b>		
<b>CHOICES: VAR T / CST VOL, CST T / VAR VOL</b>		

## Section 3

- c. Select either Integral or External flow meter and press **ACCEPT**.
- d. Enter the flow volume between samples using the numeric keypad and select a unit of measure using the **CHANGE UNITS** key, then press **ACCEPT**. Refer to [Table 2](#) for flow unit choices.

11:00 AM 21 - APR - 01		SAMPLE COLLECTION
<b>ACCEPT</b>	<b>TAKE SAMPLE EVERY:</b> 1500 gal	<b>CHANGE UNITS</b>
<b>CANCEL</b>		<b>CLEAR ENTRY</b>
<b>ENTER: 1.00—99999999</b>		

**Table 2 Sampler Pacing Flow Units**

Abbreviation	Volume
gal	gallons
ltr	liters
m <sup>3</sup>	cubic meters
af	acre-feet
cf	cubic feet

- e. Enable or Disable Timed Over-Ride using the **CHANGE CHOICE** key. Press **ACCEPT** to continue, then enter a time period using the numeric keypad.

*Note: Select Timed Over-Ride if the flow rate drops to an unusually low value during flow-proportional sampling and if the sample is collected once an hour for example, even if the flow interval has not elapsed.*

11:00 AM 21 - APR - 01		SAMPLE COLLECTION
<b>ACCEPT</b>	<b>TIMED OVER-RIDE:</b> 00:00 (hrs:min)	
<b>CANCEL</b>		<b>CLEAR ENTRY</b>
<b>ENTER: 000:01 — 999:00 (hrs:min)</b>		

- f. Select Take First Sample Immediately or After First Interval?

*Note: When the program is started, the first sample is taken immediately upon pressing the start button or after the first interval has elapsed.*

11:00 AM 21 - APR - 01		SAMPLE COLLECTION
<b>ACCEPT</b>	<b>TAKE FIRST SAMPLE:</b> _____	<b>CHANGE CHOICE</b>
<b>CANCEL</b>		
<b>CHOICES: IMMEDIATE, AFTER 1<sup>st</sup> SAMPLE</b>		

- g. Press **ACCEPT** to continue to Sample Distribution.

**Flow Proportional Constant Time, Variable Volume Sampling (CTVV)**

A Level-Velocity Sensor Input must be logged and electrically connected for the CTVV feature to work correctly.

CTVV samples are taken at user-specified constant (fixed) intervals. However the actual volume of each sampling is based on the known average flow rate of the site, the actual metered flow rate for each specific interval, the total sample volume desired, the user-specified collection period, and the specified Sampling Interval. Depending on the flow volumes of a stream and various intervals within the Collection Period, the volume of individual sampling can vary. Also, the total sample collected during the entire period can carry slightly above or below the Total Volume Desired. For these reasons, the manufacturer advises to use a sampling container that has a larger volume than the Total Volume Desired value.

- Sample Distribution menus are not available when CTVV is selected.
- A level-velocity sensor input must be logged and electrically connected for the CTVV feature to correctly work.
- The Flow Pacing Mode menu within the Flow Proportional menus sequence will not remember the previous setting whenever you re-enter this menu, it will revert to the CVVT default. When re-entering this menu, press **CHANGE CHOICE** to select the sampling method, CVVT or CTVV.

**Example:**

This is an example of how the instrument determines sample volume, based on user inputs and actual metered flow volume.

The user entered values are the following:

- Average Flow Rate (historical, site specific): 150 gph
- Sampling Interval: 2 minutes
- Total Sample Volume Desired: 1500 mL
- Collection Sampling Period: 30 minutes

Calculation 1: Total Number of Samples

$$\frac{\text{Sample Period}}{\text{Sampling Interval}} = \frac{30 \text{ min.}}{2 \text{ min.}} = 15 \text{ samples total within specified period}$$

Calculation 2: Average Sample Volume

$$\frac{\text{Total Sample Volume Desired}}{\text{Total Number of Samples}} = \frac{1500 \text{ mL}}{15 \text{ samples Total}} = 100 \text{ mL/sample}$$

Calculation 3: Sample's Volume per unit of Flow Rate

$$\frac{\text{Avg. Sample Volume}}{\text{Avg. Flow Rate}} = \frac{100 \text{ mL/Sample}}{150 \text{ gph}} = 0.7 \text{ mL/gph}$$

Calculation 4: Actual Sample Volume to be Collected

Sample Volumes per unit of Flow Rate × Actual metered Flow Rate

$$0.7 \text{ mL/gph} \times 150 \text{ gph} = 105 \text{ mL for this sample interval}$$

## Section 3

- a. In the Sample Collection menu, press **CHANGE CHOICE** until Flow Proportional is displayed. Press **ACCEPT**.

11:00 AM 21 - APR - 01		SAMPLE COLLECTION
ACCEPT	SAMPLE COLLECTION: FLOW-PROPORTIONAL	CHANGE UNITS
CANCEL		
ENTER: 1.00 - 99999999		

- b. In the Flow Pacing menu, press **CHANGE CHOICE** until Const Time/Var Vol appears. Press **ACCEPT**.

11:00 AM 21 - APR - 01		FLOW PACING
ACCEPT	FLOW PACING MODE: CONST TIME/ VAR VOL	CHANGE CHOICE
CANCEL		
CHOICES: VAR T / CST VOL, CST T / VAR VOL		

- c. In the Average Flow Rate menu use the numeric keypad to enter the known historical Average Flow Rate for a particular site.

11:00 AM 21 - APR - 01		CONST TIME/ VAR VOL
ACCEPT	AVERAGE FLOW RATE: 150.00 gph	
CANCEL		CLEAR ENTRY
ENTER: 1.00—99999999		

- d. In the Interval menu use the numeric keypad to enter the time interval between sample collections. Press **ACCEPT**.

11:00 AM 21 - APR - 01		CONST TIME/ VAR VOL
ACCEPT	INTERVAL: 0:02 (hrs:min)	
CANCEL		CLEAR ENTRY
ENTER: 1.00—999:00 (hrs:min)		

- e. In the Total Volume Desired menu use the numeric keypad to enter the total volume of the sample. Press **ACCEPT**.

11:00 AM 21 - APR - 01		CONST TIME/ VAR VOL
ACCEPT	TOTAL VOLUME DESIRED: 1500 MI	
CANCEL		CLEAR ENTRY
ENTER: 10—9999		

- f. In the Collection Period menu use the numeric keypad to enter the time period for collecting samples.

11:00 AM 21 - APR - 01		CONST TIME/ VAR VOL
ACCEPT	COLLECTION PERIOD 0:30 (hrs:min)	
CANCEL		CLEAR ENTRY
ENTER: 000:01—999:00 (hrs: min)		

- g. Press **ACCEPT** to continue to Sample Distribution.

## Step 6 - Sample Distribution

Sample distribution describes the way samples are deposited in a bottle(s). Several bottle combinations are available with the sampler ([Figure 10 on page 24](#)). Sample distribution is deposited into a single bottle or multiple bottles. Multiple bottle applications use a distributor arm to automatically aim the sample intake tubing into the proper bottle. Multiple bottle sets deliver each sample to all bottles or deliver each sample into individual bottles or a subset of bottles.

### Single Bottle

- 6-A.** Select either Stop After Last Bottle or Run Continuously Stop After Last Bottle mode stops the program when the sample is deposited into the last bottle. Run Continuously mode continues running until it is manually stopped.

11:00 AM 21 - APR - 01		SAMPLE DISTRIBUTION
ACCEPT	RUN MODE: RUN CONTINUOUSLY	CHANGE CHOICE
CANCEL		
CHOICES: CONTINUOUS, STOP AFTER LAST		

- 6-B.** Press **ACCEPT** to continue to Liquid Sensor setup.

### Multiple Bottle Sets

Multiple bottle applications use a distributor arm to automatically aim the sample intake tubing into the proper bottle. Multiple bottle sets deliver each sample to all bottles or deliver each sample into individual bottles or a subset of bottles.

- 6-A.** Select **YES** or **NO** for Deliver Each Sample to All Bottles.

11:00 AM 21 - APR - 01		SAMPLE DISTRIBUTION
ACCEPT	DELIVER EACH SAMPLE TO ALL BOTTLES?	CHANGE CHOICE
CANCEL	NO	
CHOICES: YES, NO		

If **NO** is selected:

- a. Select Samples per Bottle or Bottles per Sample.

**Example 1: Samples Per Bottle**

- Bottles— 8
- Sample Collection; Time-Proportional; Sampling Interval—30 min.
- Sample Distribution; Deliver Each Sample to All Bottles?— No  
Samples Per Bottle— Yes  
Number of Samples Per Bottle— 3
- Sample Volume—100 mL

Every 30 minutes a sample is initiated. A 100 mL sample is drawn into bottle #1, 30 minutes later a second sample is drawn into bottle #1, 30 minutes later a third sample is drawn into bottles #1. Thirty minutes later the distributor arm advances to bottle #2 and a 100 mL sample is drawn into bottle #2. The sequence continues until all bottles are filled. Each bottle receives three samples before the distributor moves to the next bottle.

**Example 2: Bottles Per Sample**

- Bottles— 4
- Sample Collection; Timed Proportional; Sampling Interval— 30 min.
- Sample Distribution; Deliver Each Sample to All Bottles?— No  
Bottles Per Sample— Yes  
Number of Bottles Per Sample— 2
- Sample Volume— 1000 mL

Every 30 minutes a sample cycle is initiated. A 1000 mL sample is drawn into the first bottle. The distributor arm immediately advances to bottle #2 and a 1000 mL sample is drawn into the second bottle. Thirty minutes later, the distributor arm advances to bottle #3, and a 1000 mL sample is taken. The distributor arm immediately advances to bottle #4 and a 1000 mL sample is drawn into the fourth bottle. The pattern continues each sample cycle with each set of two bottles receiving a sample each time.

- b. Press **ACCEPT** to continue with Liquid Sensor setup.

If **YES** is selected:

Each time a sample is taken it is consecutively placed in all bottles. This allows for split samples.

- a. Select Stop After Last Sample or Run Continuously.

11:00 AM 21 - APR - 01		SAMPLE DISTRIBUTION
<b>ACCEPT</b>	<b>RUN MODE:</b>	<b>CHANGE CHOICE</b>
<b>BACKUP</b>	<b>RUN CONTINUOUSLY</b>	
<b>CHOICES: CONTINUOUS, STOP AFTER LAST</b>		

***Note:** A high pressure air purge is automatically applied to the intake tube between each sample intake cycle.*



- b. If Stop After Last Sample is chosen, enter the samples to collect using the numeric keypad. Press **ACCEPT** to continue to Liquid Sensor.

11:00 AM 21 - APR - 01		SAMPLE DISTRIBUTION	
<b>ACCEPT</b>		<b>SAMPLES TO COLLECT:</b>	
<b>BACKUP</b>	2	<b>CLEAR ENTRY</b>	
<b>ENTER: 1 — 999</b>			

**Example 1:** The following example creates four identical composite samples automatically if the sampler is programmed as follows:

- Bottles— 4
- Sample Collection; Sampling Interval— 30 minutes
- Sample Collection; Samples to Collect— 25
- Sample Volume— 100 mL

Every 30 minutes a sample is initiated and a 100 mL sample is drawn into the first bottle. The distributor arm advances to bottle #2 and 100 mL of sample is drawn into the second. This also occurs in bottles #3 and #4.

Sampling will continue every 30 minutes until 25 samples are deposited. Once all samples are deposited the program will terminate. If Run Continuously is selected the sampling will restart automatically.

## Step 7 - Liquid Sensor

The liquid sensor contains a pair of ultrasonic transducers which sense the presence of liquid inside silicone tubing.

**7-A.** Enable or Disable Liquid Sensor using the **CHANGE CHOICE** key.

*Note: Sample retries cannot be enabled when the liquid sensor is disabled.*

### Enabling the Liquid Sensor

When the liquid sensor is enabled, the sampler will perform two duties:

- It senses when liquid reaches the pump during an intake cycle. The pump then reverses to rinse the line, up to three times.
- It senses the absence of liquid during a sample intake cycle if the intake tubing is plugged or if the water level has dropped below the level of the intake tube strainer. This initiates a Sample Retry if programmed

### Disabling the Liquid Sensor/Timed Calibration

Disabling the liquid sensor turns the liquid sensor off. The sample volume is then metered using a timed method (Timed Calibration), instead of a sensed method.

**7-B.** Press **ACCEPT** to continue to Sample Volume.

### Step 8 - Sample Volume

**Note:** The minimum sample volume is ten milliliters.

When multiple bottles are selected in Bottle Per Sample mode all bottles in a subset receive a full sample volume. The volume is not divided among the bottles.

- 8-A.** Enter the desired volume of each sample using the numeric keypad. Press **ACCEPT** to continue to Intake Rinses.

11:00 AM 21 - APR - 01		SAMPLE VOLUME
<b>ACCEPT</b>	<b>SAMPLES VOLUME:</b>	
<b>BACKUP</b>	_____	<b>CLEAR ENTRY</b>
<b>ENTER: 10 — 9999</b>		

### Step 9 - Intake Rinses

- 9-A.** Enter number of rinses using the numeric keypad. Press **ACCEPT** to continue to Sample Retries.

11:00 AM 21 - APR - 01		INTAKE RINSES
<b>ACCEPT</b>	<b>INTAKE RINSES:</b>	
<b>BACKUP</b>	0	<b>CLEAR ENTRY</b>
<b>ENTER: 0 — 3</b>		

Up to three intake rinses are enabled per sample cycle. After the sample cycle's initial purge has been completed, the sample liquid is drawn in until it reaches the liquid sensor. The pump stops and purges the line before any liquid enters the bottle. This is repeated up to three times before the actual sample is taken and the line purged for the final time during that cycle.

Intake rinse can prevent cross contamination of samples. When the line is purged at the end of each sample cycle, a few droplets of sample liquid may cling to the inside walls of the tubing and the droplets are drawn in with the following sample. Intake rinses will condition the intake line with a source liquid that minimizes contamination from the previous sample.

### Step 10 - Sample Retries

**Note:** Excessive intake tube line lengths combined with multiple Intake Rinses and Sample Retries can increase the pump tube and drive train wear. Locate the sampler as close to the sample liquid source as possible to minimize wear and maintenance requirements.

- 10-A.** Enter the number of Sample Retries using the numeric keypad. Press **ACCEPT** to continue to Site ID.

Up to three sample retries are enabled per sample cycle. After the initial purge is completed, the sample liquid is drawn until it reaches the liquid sensor. If the sample liquid does not reach the sensor within a reasonable time (determined using the tubing length), the sample attempt is aborted, a purge is initiated and the first of up to three sample retries is attempted.

After three attempts and no sample liquid has been collected, the cycle is aborted, a Missed Sample is reported to the Sample History Log, and the sampler begins a new sample interval.

## Step 11 - Site ID

**11-A.** Enter a site identification number of up to 8 digits. This Site ID will appear on all data printouts. This feature is useful when multiple sites are monitored using a single flow meter or if data readings from multiple flow meters are collected.

11:00 AM 21 - APR - 01		SITE ID
ACCEPT	SITE ID:	
BACKUP	00000000	CLEAR ENTRY
(USE NUMERIC KEYPAD)		

**11-B.** Press **ACCEPT**.

**11-C.** After Site ID is accepted the following menu will appear:

11:00 AM 21 - APR - 01		ADVANCED SAMPLING
DO YOU WISH TO ACCESS THE ADVANCED SAMPLING FEATURES?		YES
		NO
ENTER: 1 — 999		

**11-D.** If **NO**, the basic setup program is complete.

**Note:** To return to the Advanced Sampling options at a later time, from the Main Menu select, **SETUP>MODIFY SELECTED ITEMS>PROGRAM ENTRIES**. Highlight Advanced Sampling and press **SELECT**. In the Advanced Sampling menu highlight an item using the **UP** and **DOWN** keys and press **SELECT**.

11:00 AM 21 - APR - 01		PROGRAM ENTRIES
SELECT	INTAKE RINSES SAMPLE RETRIES SITE ID	↑
	ADVANCED SAMPLING	
RETURN		↓

**11-E.** If **YES**, continue to Advanced Sampling, [section 3.3](#).

## 3.3 Advanced Sampling

When enabled, the Advanced Sampling option will have an arrow pointing at it on the Advanced Sampling menu display.

Advanced Sampling Choices Include:

- Program Complete Output
- Setpoint Sampling
- Special Output
- Start/Stop Times
- Storm Water
- Timed Bottle Sets
- Upset Sample
- Variable Intervals
- Variable Volumes

## Step 12 - Program Complete Output

Program Complete Output sends a +12 V dc signal out Pin F of the Auxiliary Receptacle at the completion of the sampling program. This signal is also sent when a Full Bottle condition causes the program to complete. The Program Complete signal remains on (+12 V dc) for 61 seconds and then turns back off (0 V dc).

Program Complete Output is used for the following purposes:

- Multiple Sampler Operation. Samplers are arranged in a “Cascade” control where the first sampler signals a second sampler to start its program when the first sampler’s program is complete. This feature requires the second sampler to be programmed for external start operation.
- To interface to a PC to signal the end of the sampling program.
- To interface to a relay that trips a signal light in a control room to indicate that sampling is finished and samples are ready to be picked up.

**12-A.** From the Advanced Sampling menu highlight Program Complete using the **UP** and **DOWN** keys. Press **SELECT** to continue.

11:00 AM 21 - APR - 01		ADVANCED SAMPLING
SELECT	PGM CMLPT OUTPUT	↑
RETURN	SETPOINT SAMPLING SPECIAL OUTPUTS	↓

**12-B.** Enable or Disable Program Complete using the **CHANGE CHOICE** key.

**12-C.** Press **ACCEPT** to continue to Set Point Sampling.

## Step 13 - Setpoint Sampling

Setpoint sampling allows the control of an automatic liquid sampler from one of up to 14 sources. Setpoint sampling defines a set of limits that inhibit sampling until an upset condition occurs, causing the limits to exceed. Sampling is enabled only when the waste stream falls outside the setpoints.

**13-A.** Highlight Setpoint Sampling using the **UP** and **DOWN** keys on the Advanced Sampling Menu. Press **SELECT**.

11:00 AM 21 - APR - 01		ADVANCED SAMPLING
SELECT	PGM CMLPT OUTPUT SETPOINT SAMPLING	↑
RETURN	SPECIAL OUTPUTS START/STOP TIMES	↓

**13-B.** Enable or Disable Setpoint Sampling using the **CHANGE CHOICE** key. Press **ACCEPT** to continue.

**13-C.** Select either Start on Setpoint or Stop on Setpoint by pressing **CHANGE CHOICE**. Press **ACCEPT** to continue.

- Start on Setpoint will start a program when the setpoint condition is met. The program continues to run even if the condition falls back within the setpoint limits.
- Stop On Setpoint halts the program if the setpoint condition falls back within the setpoint limits and starts again if the limits are exceeded.

**13-D.** Highlight the desired channel to trigger from, then press **SELECT**.

**13-E.** Press either **HIGH CONDITION** or **LOW CONDITION**.

11:00 AM 21 - APR - 01		SETPOINT SAMPLING
<b>SETPOINT CONDITION:</b>		<b>HIGH CONDITION</b>
		<b>LOW CONDITION</b>

*Note: Flow Rate of Change and Rainfall are signals that only increase and never decrease in value, therefore these signals do not require Low Condition.*

The external control signal must be configured on the external equipment for the desired setpoint. An external control device must provide a dry contact and can include a float switch, push-button, external flow meter, etc. For interface connections refer to [section 2.10 on page 29](#).

**13-F.** Enable or Disable the trigger point using the **CHANGE CHOICE** key.

**13-G.** Select the desired high or low trigger point using the numeric keypad. Press **ACCEPT**. Refer to [Table 3](#).

11:00 AM 21 - APR - 01		SETPOINT SAMPLING
<b>ACCEPT</b>	<b>SETPOINT SAMPLING: HIGH TRIGGER POINT:</b>	
<b>CANCEL</b>	00000 in.	<b>CLEAR ENTRY</b>
<b>(USE NUMERIC KEYPAD)</b>		

**13-H.** Enter the Deadband value if required or, if programming Flow Rate of Change or Rainfall, enter a time interval that the flow or rainfall change must take place (refer to [section 6.4 on page 87](#)).

11:00 AM 21 - APR - 01		SETPOINT SAMPLING
<b>ACCEPT</b>	<b>SETPOINT SAMPLING DEADBAND:</b>	
<b>CANCEL</b>	0.000	<b>CLEAR ENTRY</b>
<b>(USE NUMERIC KEYPAD)</b>		

## Section 3

**13-I.** Enter a delay when input is active. This delay will keep the program from starting until the end of the delay period. Using the numeric keypad, enter the delay in minutes and/or hours. Press **ACCEPT**.

11:00 AM 21 - APR - 01		SETPOINT SAMPLING
<b>ACCEPT</b>	<b>DELAY WHEN INPUT BECOMES ACTIVE:</b>	
<b>CANCEL</b>	(hrs:min)	<b>CLEAR ENTRY</b>
<b>(USE NUMERIC KEYPAD)</b>		

**Table 3 Sampling Triggers and Settings**

Channel	Sampling Trigger	Settings
1	Level	High and/or Low Condition, Deadband
2	Flow	High and/or Low Condition, Deadband
3	Flow Rate of Change	High Condition within Time Interval
4	pH or ORP	High and/or Low Condition, Deadband
5	Process Temperature	High and/or Low Condition, Deadband
6	Rainfall	High Condition within Timed Interval
7	Analog Input Channel 1	High and/or Low Condition, Deadband
8	Analog Input Channel 2	High and/or Low Condition, Deadband
9	Analog Input Channel 3	High and/or Low Condition, Deadband
10	Analog Input Channel 4 or DO	High and/or Low Condition, Deadband
11	Analog Input Channel 5 or DO Temperature	High and/or Low Condition, Deadband
12	Analog Input Channel 6 or Conductivity	High and/or Low Condition, Deadband
13	Analog Input Channel 7 or Conductivity Temperature	High and/or Low Condition, Deadband
14	External Control	Configured in External Equipment

### Step 14 - Special Output

The Special Output is a +12 V dc signal that appears on Pin E of the Auxiliary Receptacle (refer to [section 2.10 on page 29](#)).

**14-A.** Highlight Special Output using the **UP** and **DOWN** keys on the Advanced Sampling Menu. Press **SELECT** to continue.

11:00 AM 21 - APR - 01		ADVANCED SAMPLING
<b>SELECT</b>	<b>PGM CMLPT OUTPUT SETPOINT SAMPLING SPECIAL OUTPUTS</b>	↑
<b>RETURN</b>	<b>START/STOP TIMES STORM WATER</b>	↓

**14-B.** Enable or Disable Special Outputs using the **CHANGE CHOICE** key. Press **SELECT** to continue.

**14-C.** If enabled, select After Each Sample, Only When Pumping, or From Rinse to Purge.

**Bottle Number**

If the Program Complete Output is disabled, then it is used in conjunction with this Special Output to transmit the bottle number to the connected device.

The Special Output signal can be configured to activate during one of the following conditions:

- **After Each Sample**—One second pulse at the completion of each sample cycle. It signals an external datalogger or PC that a sample cycle was initiated. When this choice is enabled, the sample success/failure is also transmitted to the external datalogger by means of Pin F on the Auxiliary connector.
- **Only When Pumping**—During sample intake portion of cycle only, ignoring all purges and rinse cycles. Used for tripping solenoid or ball valves when sampling from a pressurized line.
- **From Rinse To Purge**—During entire sample cycle, including all purge and rinse cycles. Used for tripping solenoid or ball valves when sampling from a pressurized line.

**Step 15 - Start/Stop Times**

Start/Stop Times start and stop a program at pre-arranged times. For example, this feature can be used to run a program during weekdays and stop the program during weekends, restarting on the following Monday. It can also halt sampling for nighttime shutdowns.

Up to 12 Start and 12 Stop time entries can be set in any one program. Either a Start Time and Date or a Start Time and Day of the Week may be selected.

**15-A.** Highlight the Start/Stop Time choices on the Advanced Sampling menu. Press **SELECT** to continue.

11:00 AM 21 - APR - 01		ADVANCED SAMPLING
SELECT	PGM CMPLT OUTPUT	↑ ↓
	SETPOINT SAMPLING	
SPECIAL OUTPUT		
<b>START/STOP TIMES</b>		
STORM WATER		
RETURN	TIMED BOTTLE SETS	

**15-B.** Enable or Disable Start/Stop Times using the **CHANGE CHOICE** key. Press **ACCEPT** to continue.

**15-C.** Press **CHANGE CHOICE** to select either Time/Date or Time/Weekday. Select Time/Date if the start and stop times are longer than one week. Select Time/Weekday if the program repeats on a daily or weekly basis.

**15-D.** Press **ACCEPT** to continue.

**15-E.** Enter the Start Time #1, press **ACCEPT** to continue. Enter Stop Time # and press **ACCEPT** to continue.

11:00 AM 21 - APR - 01		START/STOP TIMES	
<b>ACCEPT</b>	<b>PROGRAM START #</b>	<b>1</b>	<b>CHANGE AM/PM</b>
	<b>(TIME:DAY)</b>		
<b>CLEAR ENTRY</b>			<b>CHANGE DAY</b>
<b>HIT CLEAR, THEN ACCEPT, AFTER LAST ENTRY</b>			

11:00 AM 21 - APR - 01		START/STOP TIMES	
<b>ACCEPT</b>	<b>PROGRAM STOP #</b>	<b>1</b>	<b>CHANGE AM/PM</b>
	<b>(TIME:DATE)</b>		
<b>CLEAR ENTRY</b>			<b>CHANGE DAY</b>
<b>HIT CLEAR, THEN ACCEPT, AFTER LAST ENTRY</b>			

**15-F.** Continue entering Start and Stop times until finished. To exit and save entries, enter a blank time and date. Press **CLEAR ENTRY** and then press **ACCEPT** to continue to Storm Water.

## Step 16 - Storm Water

EPA regulations for storm water discharges require monitoring of precipitation, flow, and water samples in order to assess the impact of storm or snow melt runoff on receiving waters. The manufacturer can help you create a storm water monitoring system that consists of a multiple bottle sampler, an external flow meter, and a tipping bucket rain gauge.

In addition to performing basic sampling routines, 900 MAX Series Samplers that are equipped with the storm water monitoring program have the following additional capabilities:

- The storm water sampling routine allows collection of automatic grab sample(s) at user-selectable timed intervals (up to 24 different intervals may be selected) during the storm's early stage or "first flush." First flush grab and main program flow weighted composite samples are automatically segregated. The first flush sample volume may be set independently of the sample volume for the flow weighted composite.
- The special storm water program allows an external device to initiate the start of the sampling program. A dry contact closure across Pins B and D on the Auxiliary receptacle, held closed for at least 61 seconds, is required.
- When sampling with multiple bottles, the sampler can be programmed to collect one large "first flush" sample (or small multiple samples) at timed interval(s). The number of bottles segregated for the first flush sample is selectable. Concurrently, flow weighted samples are collected from the beginning of the storm until all remaining bottle(s) are filled, or after a user selected time has elapsed.



- Storm water samplers are equipped with a special prerinse that occurs only with the first sample collection. This “one time only” rinse ensures a clean intake for installations that may remain dormant for extended periods, and extends battery life by eliminating the prerinse for subsequent samples.

**16-A.** Highlight Storm Water using the **UP** and **DOWN** keys on the Advanced Sampling Menu. Press **SELECT** to continue.

<b>11:00 AM 21 - APR - 01</b>		<b>ADVANCED SAMPLING</b>
<b>SELECT</b>	SETPOINT SAMPLING SPECIAL PUTPUT START/STOP TIMES <b>STORM WATER</b>	↑
<b>RETURN</b>	TIMED BOTTLE SETS UPSET SAMPLE	↓

**16-B.** Enable or Disable Storm Water using the **CHANGE CHOICE** key. Press **ACCEPT** to continue.

**16-C.** Select a Start Condition using the **CHANGE CHOICE** key.

- Rain
- Level
- Rain or Level (either conditions must be met for the program to begin)
- Rain and Level (both conditions must be met for the program to begin)
- Immediate (program starts as soon as the **RUN** key is pressed, a start condition is not required)
- External Trigger (program starts when signaled by an external device at least 61 seconds through the Auxiliary connector. No start condition is required).

**16-D.** Enter the Start Condition Limits. Rainfall times will depend on the historical rainfall in a specific area. Consult your state or an EPA regional office for details.

**Table 4 Start Condition Requirements**

Rain	Enter the amount of rainfall and the time period when it must fall.
Level	Level Limit
Rain and Level	Enter the amount of rainfall and the time period when it must fall, and desired level limit.
Immediate	No start condition required
External Trigger	No start condition required

**First Flush Bottles**

First flush describes the initial storm water runoff. This runoff may contain higher concentrations of pollutants and is sequestered in separate bottles from the flow or time-weighted composite samples.

- Enter the number of bottles to set aside for the First Flush portion of the sampling program using the numeric keypad.

## Section 3

The number of first flush bottles will depend on the sample volume requirements in the NPDES permit.

11:00 AM 21 - APR - 01		STORM WATER
ACCEPT	FIRST FLUSH: NUMBER OF BOTTLES:	
CANCEL	1	CLEAR ENTRY
ENTER: 1— 4		

- b. Enter number of samples to collect using the numeric keypad.

11:00 AM 21 - APR - 01		STORM WATER
ACCEPT	FIRST FLUSH: SAMPLER TO COLLECT:	
CANCEL	6	CLEAR ENTRY
ENTER 1 — 999		

- c. Enter the first flush sampling interval. This is the time period between sample cycles. The first flush samples are usually collected within thirty minutes of the storm.

11:00 AM 21 - APR - 01		SETPOINT SAMPLING
ACCEPT	FIRST FLUSH INTERVAL:	
CANCEL	(hrs:min)	CLEAR ENTRY
ENTER: 000:00 — 999:00 (hrs:min)		

Variable time intervals may be entered or the same interval may be carried through the entire first flush. Pressing **FINAL ENTRY** carries the last displayed interval through the remainder of the first flush sampling period.

- d. Enter the first flush sample volume using the numeric keypad.

11:00 AM 21 - APR - 01		STORM WATER
ACCEPT	FIRST FLUSH: SAMPLE VOLUME	
CANCEL	100 mL	CLEAR ENTRY
ENTER 10 — 9999		

- e. Enable or Disable Program Time Limit using the **CHANGE CHOICE** key. When enabled, the Program Time Limit will stop all sampling activity at the end of the time limit, however data logging will continue.

- f. Enter the Program Time Limit. NPDES typically requires monitoring during the first three hours of any given storm. If the flow volume was not as high as expected, flow-weighted sampling could continue for some time as flow rates drop off and sample intervals become longer.

11:00 AM 21 - APR - 01		SETPOINT SAMPLING
ACCEPT	STORM WATER: PROGRAM TIME LIMIT:	
CANCEL	(hrs:min)	CLEAR ENTRY
ENTER: 000:01 — 999:00 (hrs:min)		

- g. Press **ACCEPT** to continue to Timed Bottle Sets.

## Step 17 - Timed Bottle Sets

Timed Bottle Sets enables a single sampler to function like multiple samplers. Timed Bottle Sets takes a 24-bottle sampler and sample using the first 12 bottles on the first day and the second bottles on the next day.

When a subset of bottles is set aside for each user defined time interval the sampler will treat that subset as if it were the entire set. At the end of the time interval the sampler will switch to the next subset and continue sampling.

- 17-A.** Highlight Timed Bottle Sets using the **UP** and **DOWN** keys on the Advanced Sampling Menu. Press **SELECT** to continue.

11:00 AM 21 - APR - 01		ADVANCED SAMPLING
SELECT	SPECIAL PUTPUT START/STOP TIMES STORM WATER <b>TIMED BOTTLE SETS</b>	↑
RETURN	UPSET SAMPLE VARIABLE INTERVALS	↓

- 17-B.** Enable or Disable Timed Bottle Sets using the **CHANGE CHOICE** key. Press **ACCEPT** to continue.

- 17-C.** Select a method for switching bottle sets. Select either clock time that switches bottle sets every 24 hours or select duration that sets the bottles sets in minutes and hours.

11:00 AM 21 - APR - 01		TIMED BOTTLE SETS
ACCEPT	USE CLOCK TIME OR DURATION: DURATION (hh:mm)	CHANGE CHOICE
CANCEL		

The number of bottles that were selected in bottles-per-sample mode are used as the bottle set size. Two bottles per-sample means two bottles per Timed Bottle Set.

**17-D.** Enable or Disable Continuous Mode using the **CHANGE CHOICE** key. If Continuous Mode is enabled the program will continuously run and switch bottle sets after every specified duration elapses, until manually stopped. If Continuous Mode is disabled, then the sampling halts when the last bottle set in the tray is full.

**17-E.** Press **ACCEPT** to continue to Upset Sample.

**Step 18 - Upset Sample**

Upset Sampling analyzes the collected samples to determine when samples meet or exceed specified upset limits. The sampler will swing the distributor arm around to a sequestered set of bottles and grab an upset bottle.

The upset sample bottles are always the last bottles in the tray. For example, if there are 24 bottles in the tray, 4 first flush bottles and 4 upset bottles, then the bottles assignment is 1–4 first flush, 5–20 main program, and 21–24 upset samples.

***Note:** Unlike Setpoint Sampling, Upset Sampling can be enabled while the sampler is performing its regular sampling program. There must be more than one bottle in the sampler to perform Upset Sampling.*

Upset Samples are collected even when there are no more regular samples to be taken; when the status screen says Program Complete, but the bottom line of the display says Program Running.

Refer to the [Quick Start Guides on page 103](#) for more setup information for individual channels.

**18-A.** Highlight Upset Sampling using the **UP** and **DOWN** keys on the Advanced Sampling Menu. Press **SELECT** to continue.

<b>11:00 AM 21 - APR - 01</b>		<b>ADVANCED SAMPLING</b>
<b>SELECT</b>	START/STOP TIMES STORM WATER TIMED BOTTLE SETS <b>UPSET SAMPLING</b>	↑
<b>RETURN</b>	VARIABLE INTERVALS VARIABLE VOLUME	↓

**18-B.** Enable or Disable Upset Sampling using the **CHANGE CHOICE** key. Press **ACCEPT** to continue.

**18-C.** Press **CHANGE CHOICE** to select the desired channel to trigger from. Press **ACCEPT** to make the selection.

**18-D.** Press either **HIGH CONDITION** or **LOW CONDITION**.

- Flow Rate of Change and Rainfall are signals that only increase in value and do not require Low Condition.
- The external control signal (such as an external flow meter) must be configured in the external equipment for the desired setpoint.

<b>11:00 AM 21 - APR - 01</b>		<b>UPSET SAMPLES</b>
<b>UPSET CONDITION:</b>		<b>HIGH CONDITION</b>
		<b>LOW CONDITION</b>

**18-E.** Enter the desired high or low trigger point using the numeric keypad.  
Press **ACCEPT** to continue.

11:00 AM 21 - APR - 01		UPSET SAMPLES
<b>ACCEPT</b>	<b>UPSET SAMPLING:</b>	
	<b>HIGH TRIGGER POINT:</b>	
<b>CANCEL</b>	00000 in.	<b>CLEAR ENTRY</b>
<b>(USE NUMERIC KEYPAD)</b>		

**18-F.** Enter the Deadband value or, if programming for Flow Rate Of Change or Rainfall, enter a time interval when the flow or rainfall change must take place (refer to [Alarm Relays Programming on page 91](#)).

11:00 AM 21 - APR - 01		UPSET SAMPLES
<b>ACCEPT</b>	<b>UPSET SAMPLING</b>	
	<b>DEADBAND:</b>	
<b>CANCEL</b>	0.000	<b>CLEAR ENTRY</b>
<b>(USE NUMERIC KEYPAD)</b>		

**18-G.** Enter the number of bottles (out of the total set) to set aside for upset samples. These will be the last bottles in the tray.

11:00 AM 21 - APR - 01		UPSET SAMPLES
<b>ACCEPT</b>	<b>UPSET SAMPLING:</b>	
	<b>NUMBER OF BOTTLES</b>	
<b>CANCEL</b>	2	<b>CLEAR ENTRY</b>
<b>ENTER 1 — 4</b>		

**18-H.** Select the method of distribution, Sample Per Bottle or Bottles Per Sample.

**18-I.** Enter the sample volume using the numeric keypad.

11:00 AM 21 - APR - 01		UPSET SAMPLES
<b>ACCEPT</b>	<b>UPSET SAMPLING</b>	
	<b>SAMPLE VOLUME:</b>	
<b>CANCEL</b>	0000	<b>CLEAR ENTRY</b>
<b>ENTER 10 — 9999</b>		

**18-J.** Press **ACCEPT** to continue to Variable Intervals.

Step 19 - Variable Intervals

19-A. Highlight Variable Intervals using the **UP** and **DOWN** keys on the Advanced Sampling Menu. Press **SELECT** to continue.

11:00 AM 21 - APR - 01		ADVANCED SAMPLING
SELECT	STORM WATER	↑
	TIMED BOTTLE SETS	
UPSET SAMPLING		
<b>VARIABLE INTERVALS</b>		
RETURN	VARIABLE VOLUME	↓

19-B. Enable or Disable Variable Intervals using the **CHANGE CHOICE** key. Press **ACCEPT** to continue.

19-C. Set sample intervals using the numeric keypad. Press **ACCEPT** to enter another interval or press **ACCEPT AS FINAL** to return to the Advanced Sampling menu and continue to Variable Volumes.

Step 20 - Variable Volume

20-A. Highlight Variable Volume using the **UP** and **DOWN** keys on the Advanced Sampling Menu. Press **SELECT** to continue.

11:00 AM 21 - APR - 01		ADVANCED SAMPLING
SELECT	TIMED BOTTLE SETS	↑
	UPSET SAMPLES	
	VARIABLE INTERVALS	
<b>VARIABLE VOLUME</b>		
RETURN		↓

20-B. Enable or Disable Variable Volume using the **CHANGE CHOICE** key. Press **ACCEPT** to continue.

20-C. Enter the Sample Volume counts using the numeric keypad. Press **ACCEPT** to return to the Advanced Sampling Menu.

## 4.1 Downlook Ultrasonic Sensor

### 4.1.1 Downlook Ultrasonic Sensor Connection

The downlook ultrasonic sensor connection is located on the back side of the refrigerated cabinet. The gray rectangular box houses the ultrasonic module and the transducer connector labeled ULTRASONIC. The connector is keyed and can only be inserted in the proper orientation (key up).

### 4.1.2 Downlook Ultrasonic Sensor Programming

The downlook ultrasonic sensor does not require specific programming, unless more than one sensor option is connected to the sampler. When more than one sensor option is connected to the sampler:

1. From the Main Menu, select **OPTIONS>LEVEL SENSOR**.
2. Select Ultra-Sonic using the **CHANGE CHOICE** key. Press **ACCEPT**.

### 4.1.3 Downlook Ultrasonic Sensor Calibration

Calibrate the current water level via one of two methods; Liquid Depth or Sensor Height. An Invisible Range can also be set which allows the transducer to ignore reflections from obstructions between the sensor and the water surface, such as ladder rungs, channel side walls, etc. Each method has its own advantages and disadvantages; selecting the proper method will depend upon the site conditions. Calibrate the ultrasonic sensor each time the sensor is installed at a new site.

#### 4.1.3.1 Liquid Depth

This method requires the level or depth of liquid in the channel that is contributing to flow. In a round pipe, the entire depth typically contributes to flow. In a weir, only the depth that is flow over the weir plate contributes to flow. Level Depth calibration is primarily used when:

- Access is available to the primary device for a physical measurement of the liquid depth, and
- When water is flowing during installation (channel is not dry).

**Note:** Always re-check the Level Adjust when re-installing the flow meter.

1. From the Main Menu, select **OPTIONS>ADVANCED OPTIONS>CALIBRATION>ULTRASONIC SENSOR**.
2. Select Calibrate U-Sonic using the **UP** and **DOWN** keys. Press **SELECT**.
3. Select Standard as the type of Ultrasonic Transducer using the **CHANGE CHOICE** key. Press **ACCEPT** to continue.

#### Temperature Time Constant

The speed of sound in air varies with the temperature of the air. The ultrasonic sensor is equipped with temperature compensation to help eliminate the effect of temperature variation under normal site conditions. The transducer must be equal to the ambient air temperature at the site prior to calibration for optimum results. The manufacturer recommends that sensors be shielded from direct sunlight for this reason.

4. Enter the ambient air temperature at the transducer location. For optimum results, allow enough time (100 minutes) to ensure that the sensor is at equilibrium with the surrounding ambient temperature. Press **ACCEPT**.
5. Select the Liquid Depth method and enter the new level.
6. Take a physical measurement of the liquid depth (level) and enter the value. Press **ACCEPT** when finished.

### 4.1.3.2 Sensor Height

This method requires entering the distance between the face of the ultrasonic sensor and the zero flow point in the primary device. The zero flow point in a primary device is the level at which flow ceases. In a round pipe the zero flow point would typically be the invert or bottom of the pipe. In a V-notch weir the zero flow point occurs when the liquid behind the weir is level with the bottom of the 'V'. (There would still be liquid behind the weir plate but it would not be contributing to flow). Sensor Height calibration is generally used when:

- Access to the primary device is difficult (such as confined space entry in a manhole) or
- There is no liquid flowing during installation of the flow meter

1. From the Main Menu, select **OPTIONS>ADVANCED OPTIONS>CALIBRATION>ULTRASONIC SENSOR**.
2. Select Calibrate U-Sonic using the **UP** and **DOWN** keys. Press **SELECT**.
3. Select Standard as the type of Ultrasonic Transducer using the **CHANGE CHOICE** key. Press **ACCEPT** to continue.

The speed of sound in air varies with the temperature of the air. The ultrasonic sensor is equipped with temperature compensation to help eliminate the effect of temperature variation under normal site conditions.

4. Enter the ambient air temperature at the transducer location. For optimum results, allow enough time (100 minutes) to ensure that the sensor is at equilibrium with the surrounding ambient temperature. Press **ACCEPT**.
5. Select the Sensor Height method and enter the new level.
6. Enter the distance from the face of the transducer to the zero flow point of the primary device.
7. Press **ACCEPT** when finished.

### 4.1.3.3 Setting the Invisible Range

1. From the Main Menu, select **OPTIONS>ADVANCED OPTIONS>CALIBRATION>ULTRASONIC SENSOR**.
2. Select the Invisible Range option using the **UP** and **DOWN** keys. Press **SELECT** to continue.
3. Enter the Distance to End of the Invisible Range.



4. Select either inches or centimeters using the **CHANGE UNITS** key. The distance must be greater than the minimum deadband of 10 in. (25.4 cm) for the 75 kHz sensor and 15 in. (38.1 cm) for the 50 kHz sensor.
5. Press **ACCEPT** when finished.

## 4.2 Submerged Area/Velocity Sensor

The Submerged area/velocity sensor simultaneously measures level and velocity.

### 4.2.1 Submerged Area/Velocity Sensor Connection

**Table 5 Submerged/Area Velocity Sensor Connection**

Pin	Signal Description	Wire Color	Bare Leads
A	+12 V dc	Red	Red
B	ground	Green	Green
C	Receive (ground)	B/W Shield	Yellow
D	Receive (+)	B/W Center	Orange
E	Transmit (ground)	Black Shield	Violet
F	Transmit (+)	Black Center	Gray
G	Depth (-)	Black	Black
H	Depth (+)	White	White

#### **Recommended Routing of Submerged Area/Velocity Cable**

Proper routing of the cable serves two functions:

- Keeps the in-line desiccant assembly inside the cover and out of the way when installing and removing the sampler from tight manholes.
- Keeps the desiccant out of direct contact with the elements. Also, keeps water from dripping directly onto the desiccant assembly.

To secure the submerged area velocity cable, route the cable around the battery and clip it under the battery hold downs.

### 4.2.2 Submerged Area/Velocity Sensor Programming

1. From the Main Menu, select **OPTIONS>LEVEL SENSOR**.
2. Select Submerged Xducer using the **CHANGE CHOICE** key. Press **ACCEPT**.
3. From the **MAIN MENU**, select **SETUP>MODIFY SELECTED ITEMS**.
4. Highlight Velocity Direction using the **UP** and **DOWN** keys. Press **SELECT**.
5. Set the velocity direction (upstream, downstream, or always positive) using the **CHANGE CHOICE** key. Press **ACCEPT** to continue.
6. Highlight Velocity Units using the **UP** and **DOWN** keys. Press **SELECT**.

7. Set the Velocity Units (fps or m/s), using the **UP** and **DOWN** arrow keys. Press **ACCEPT** to continue.
8. Highlight Velocity Cutoff, using the **UP** and **DOWN** keys. Press **SELECT**.
9. Read the Velocity Cutoff information screen. Press any key to continue.
10. Set the Velocity Cutoff using the numeric keypad. Press **ACCEPT**.
11. Set the Velocity Default, using the numeric keypad. Press **ACCEPT**. Press **RETURN** to go back to the Setup Menu or **Main Menu** to return to the Main Menu display.

### 4.2.3 Submerged Area/Velocity Submerged Area/Velocity Sensor Calibration

This calibration requires a graduated cylinder or bucket with at least 16 cm (6 in.) of water and a ruler. Calibrating the Submerged Area/Velocity Sensor characterizes the sampler electronics to the unique characteristics of each individual sensor. In addition, the calibration compensates for any sensor drift that may occur over time (6 months or greater) as the materials in the sensor age.

The Submerged Area/Velocity Sensor is a pressure transducer that contains a stainless steel diaphragm. As the water pressure increases, (with increasing level in the flow stream) the diaphragm is deflected, or pushed, against a solid state device called a strain gauge. The strain gauge converts the pressure against the diaphragm to a voltage. As the level in the flow stream increases, so does the voltage coming from the Submerged Area/Velocity Sensor. The voltage is read by the microprocessor in the sampler at regular intervals and converted to a number that represents the level in the flow stream.

The manufacturer recommends calibrating the submerged area/velocity sensor when:

- The sensor is first used.
- Installing a new or different sensor on a flow meter or input receptacle.
- The difference between the level reading of the flow meter and the independent verification (measurement with a dipstick or ruler) is increasing.

**Note:** *The data is constant if the difference between the level reading of the flow meter and the independent verification is constant; recalibration is not required.*

**Note:** *Errors can occur with the flow meter level reading and the independent verification. Errors are caused by variation in site conditions and measurement abilities. These errors may cause slight changes in the difference, therefore, not indicating a true change in the difference.*

1. From the Main Menu, select **OPTIONS > ADVANCED OPTIONS > CALIBRATION > SUBMERGED PROBE**.
2. Place the sensor flat on a table top or floor with the sensor (the plate with holes) facing down onto the surface ([Figure 17](#)). Press any key to continue.

**Note:** Always check the Level Adjust when reinstalling the sampler following a calibration. (See [Keypad Description on page 16.](#))

3. Place the sensor face up in the bucket or liquid. Tap lightly to remove air bubbles. If these bubbles are not removed you can receive false readings from the sensor during calibration ([Figure 17](#)).
4. Place the sensor face down under at least 16 cm (6 in.) of water and wait 20 seconds. Make sure the water surface is calm and the sensor is stable.
5. Press any key to continue.
6. Measure the depth from the bottom of the bucket to the surface of the water and enter the value using the numeric keypad ([Figure 17](#)).
7. Press **ACCEPT**.

**Figure 17** Calibrating the Submerged Area/Velocity Sensor

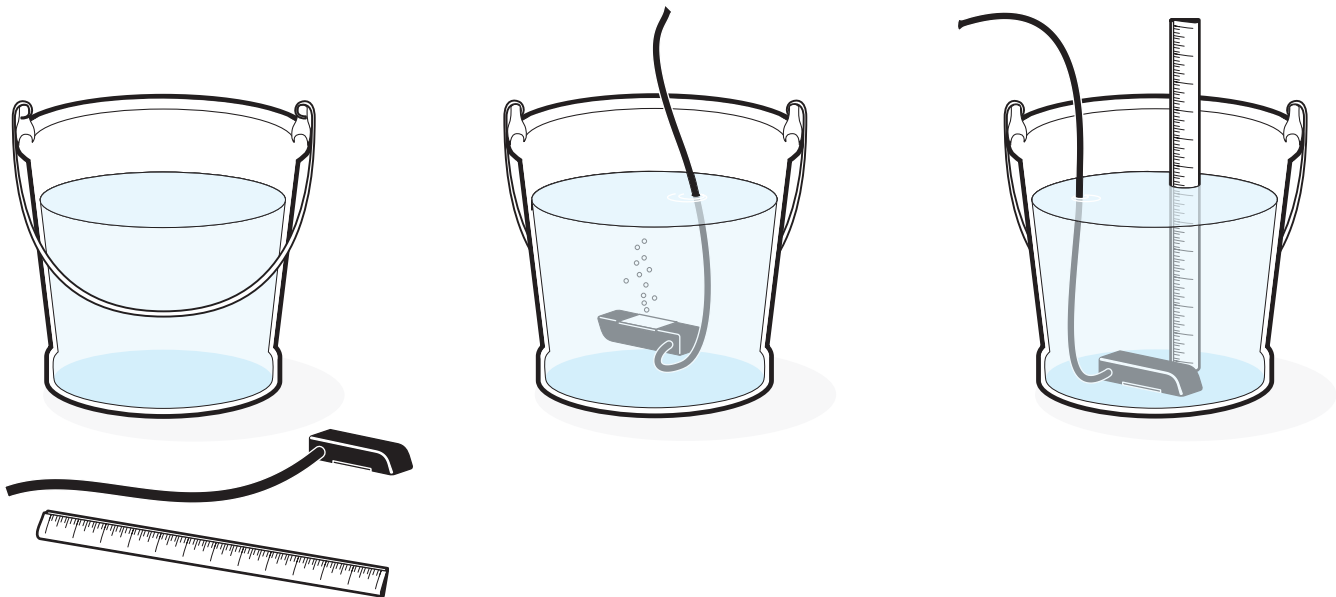

### 4.3 Submerged Pressure Sensor

The submerged pressure sensor is a pressure transducer that contains a titanium diaphragm. As the water pressure increases, (with increasing level in the flow stream) the diaphragm is deflected, or pushed, against a solid state device called a strain gauge. The strain gauge converts the pressure against the diaphragm to a voltage. As the level in the flow stream increases, the voltage coming from the submerged pressure sensor increases. The voltage is read by the microprocessor in the Sampler at a regular interval and converted to a number which represents the level in the flow stream. The level reading can then be converted by the meter to a flow rate based on the mathematical formula for the selected primary device.

#### 4.3.1 Submerged Pressure Sensor Connection

The submerged pressure sensor connection is located on the left side of the controller housing and is labeled submerged pressure sensor. The connector is keyed and can only be inserted in the proper orientation (key up).

**Table 6 Submerged Level Sensor Base Board Connection (J21)**

Pin	Signal Description	Wire Color
A	V +	Red
B	Out +	Yellow
C	Out -	Green
D	Ground	Black

### 4.3.2 Submerged Pressure Sensor Programming

1. From the Main Menu, select **OPTIONS>LEVEL SENSOR**.
2. Select Submerged Xducer using the **CHANGE CHOICE** key and press **ACCEPT**.

### 4.3.3 Submerged Pressure Sensor Calibration

In sites with harsh conditions (extremes of level, temperature, harsh chemicals, etc.) calibration should be performed more often.

1. From the Main Menu, select **OPTIONS > ADVANCED OPTIONS > CALIBRATION > SUBMERGED PROBE**.
2. Choose the orientation that the sensor will be mounted in the flow stream, horizontal or vertical, using the **CHANGE CHOICE** key. Press **ACCEPT**.

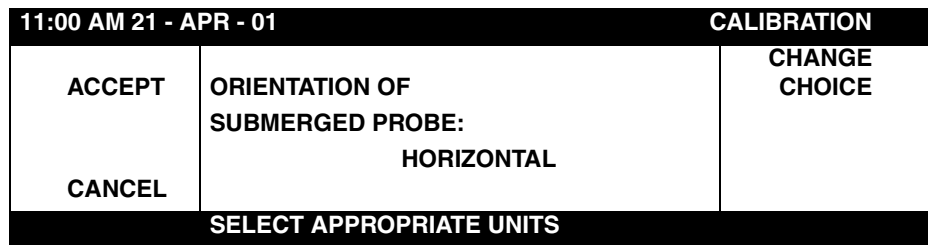

3. Lift the sensor out of the water and hold it in the air in the same orientation that you selected in the previous step (horizontal or vertical) ([Figure 18](#)). Then press **ACCEPT** to continue.

**Figure 18 Lifting the Sensor Out of the Water**

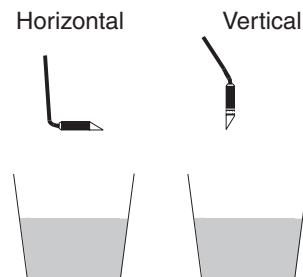

4. Follow either the vertical or horizontal procedure below.

### Vertical Orientation Only

- a. Place the sensor under at least 16 cm (6 in.) of water in a vertical orientation. Make sure the sensor is stable and not moving around. Then press **ACCEPT** to continue.
- b. Carefully measure the depth ( $D_1$ ) from the surface of the water to the first weld mark that encircles the sensor body just above the breather vent holes (Figure 19). The weld mark indicates the location of the internal diaphragm.
- c. Enter the depth ( $D_1$ ) and press **ACCEPT** when done.

**Figure 19** Measuring Submerged Depth, Vertical Orientation

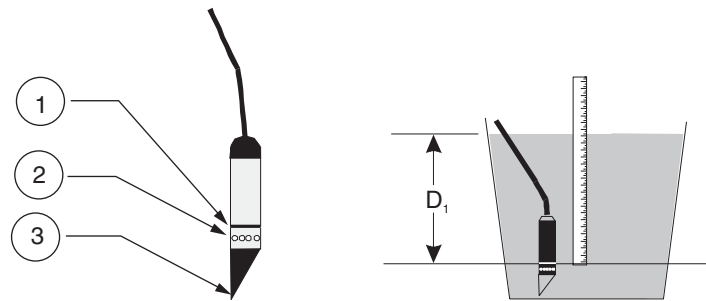

1. Gray Band	2. Breather Vents	3. Detachable Nose Cone
--------------	-------------------	-------------------------

### Horizontal Orientation Only

**Note:** Always check the Level  
Adjust when reinstalling the sampler  
following a calibration.

- a. Place the sensor under at least 16 cm (6 in.) of water in a horizontal orientation. Make sure the sensor is stable and not moving around. Then press **ACCEPT** to continue.
- b. Measure the depth from the bottom of the bucket to the surface of the water ( $D_1$ ) (Figure 20) and enter the value. Press the **ACCEPT**.

**Figure 20** Measuring Submerged Depth, Horizontal Orientation

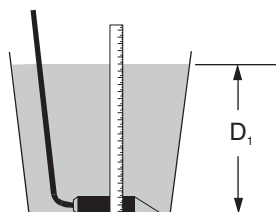



This section describes how to setup a rain gauge to the Sampler as well as how to connect, program, calibrate, and maintain the optional water quality probes:

- Rain Gauge (section 5.1 on page 69)
- pH Probe (section 5.2 on page 70)
- ORP Probe (section 5.3 on page 72)
- Dissolved Oxygen Probe (section 5.4 on page 74)
- Conductivity Probe (section 5.5 on page 76)

## 5.1 Rain Gauge

An external “tipping bucket” rain gauge (Cat. No. 2149) can be connected to the Rain Gauge connector of the sampler (Figure 21). The rain gauge provides a dry contact closure to the sampler.

As rainfall collects in the 20 cm (8 in.) diameter funnel, it is directed into one side of a “tipping bucket” assembly. As each bucket fills, it causes the bucket assembly to tip and empty out into the bottom of the rain gauge. Each tip of the bucket causes a single contact closure to the rain gauge and sends a short 12 V dc pulse into pin C of the Rain Gauge connector. Each pulse (tip) represents 0.025 cm (0.01 in.) of rain.

**Figure 21 Rain Gauge Tipping Bucket**

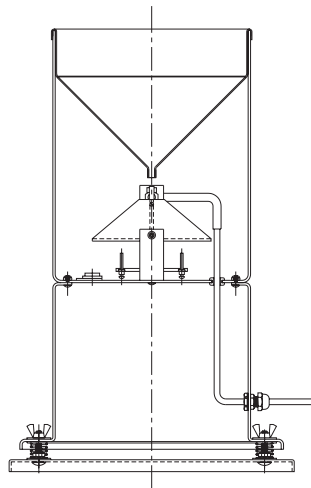

**Table 7 Rain Gauge Base Board Connections (J5)**

Pin	Signal Description
A	+12 V dc source output
B	not used
C	+12 V dc pulse input
D	not used
E	not used
F	not used

### 5.1.1 Rain Gauge Programming

**Note:** When logging is enabled, an arrow will point to the logged channel.

1. From the Main Menu select **OPTIONS>ADVANCED OPTIONS>DATALOG**.
2. Highlight **Select Inputs** using the **UP** and **DOWN** keys and press **SELECT**.
3. Highlight Rainfall using the **UP** and **DOWN** keys and press **SELECT**.
4. Press the **CHANGE CHOICE** key to cycle between Logged and Not Logged, then press **ACCEPT**.
5. Enter a logging interval using the numeric keypad, then press **ACCEPT**. Valid logging intervals are shown on the status bar along the bottom edge of the display.
6. Select Rainfall Units (in. or cm).
7. Select another channel to configure, or press **RETURN** to back up one step. Press the **MAIN MENU** key to return to the Main Menu.

## 5.2 pH Probe

The pH probes are shipped with a wetting cap that covers the probe tip. Remove the cap by turning it counter-clockwise and gently easing it off. Keep this cap for long-term probe storage. Rinse the probe tip with distilled water.

Store the probe in a pH 4.0 buffer (Cat. No. 2104) for both overnight and long term storage. Never store a probe in distilled or deionized water because this will deplete the probe filling solution.

### 5.2.1 pH Probe Connection

This connector is for installing the pH or ORP pre-amp interface junction box or a stand-alone temperature sensor. The pH probe is attached to a terminal strip in the junction box. The stand-alone temperature probe plugs directly into the receptacle on the case.

The pre-amplifier junction box is provided to allow for fast, easy replacement of the pH probe.

**Table 8 pH Connector Pin Assignments (J3)**

Pin	Signal Description	Wire Color
A	+5 V dc	White
B	ground	Blue
C	reference	Yellow
D	pH/ORP	Black
E	-5 V dc	Red
F	RTD	Green

Since the pH reading needs to compensate for temperature variation, a temperature sensor is built into every pH electrode. The pH probe consists of five wires, three for the pH probe and two for the temperature sensor.

Stray electrical currents are sometimes found in wastewater stream. These stray electrical currents can affect the pH readings. In the case of stray electrical currents, a grounded pH probe is required. See [Figure 22](#).



Figure 22 pH Probe Wiring to Junction Box (grounded)

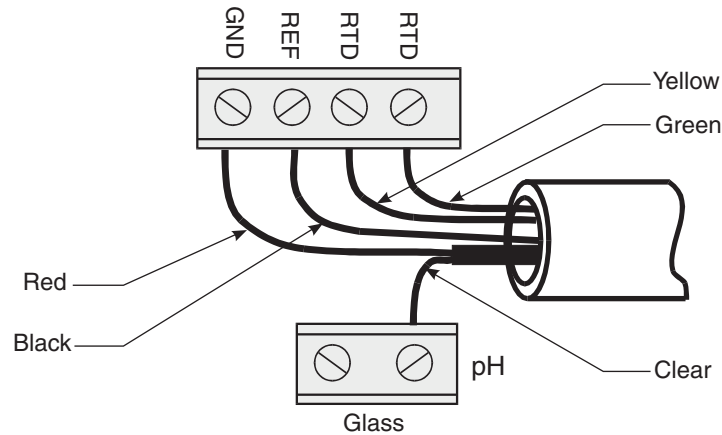
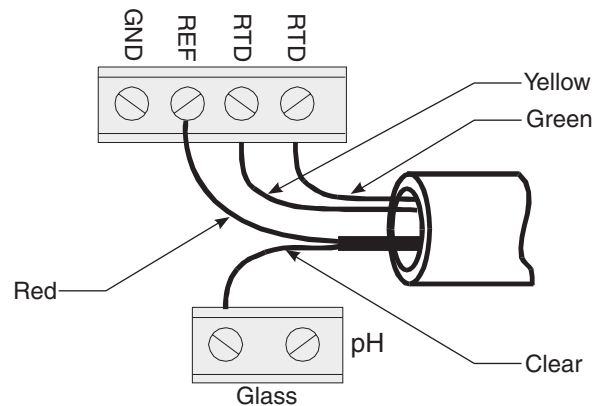

Figure 23 pH Probe Wiring to Junction Box (un-grounded)



## 5.2.2 pH Probe Programming

1. From the Main Menu, select **OPTIONS>ADVANCED OPTIONS>DATALOG**.
2. Highlight Select Inputs using the **UP** and **DOWN** keys and press **SELECT**.
3. Highlight pH using the **UP** and **DOWN** keys, then press **SELECT**.
4. Press the **CHANGE CHOICE** key to cycle between Logged and Not Logged, then press **ACCEPT**.
5. Enter a logging interval, then press **ACCEPT**. Valid logging intervals are shown on the status bar along the bottom edge of the display.
6. Select another channel to configure or press **RETURN** to back up one step. Press **MAIN MENU** to return to the Main Menu display.

## 5.2.3 pH Probe Calibration

Calibrate the pH probe after the pH probe is connected and programmed. Calibrating the pH probe requires a thermometer and any two of the following buffer solutions: 4, 7, or 10 pH.

The pH probe is an application sensitive device. When used in harsh environments, the accuracy and life expectancy of pH probes can decrease.

Probes must be calibrated to the sampler each time they are cleaned or replaced. Regular inspection and comparison to a hand-held pH meter can help determine the optimum cleaning and calibration schedule for specific applications.

1. From the Main Menu, select **OPTIONS > ADVANCED OPTIONS > CALIBRATION > pH**.
2. Place the pH probe into the first buffer solution, then press any key to continue.
3. Enter the temperature of the first buffer solution using the numeric keypad. Press **ACCEPT** to continue.
4. Select the pH for the first buffer solution (4, 7, or 10 pH) using the **CHANGE CHOICE** key, then press **ACCEPT**.
5. Remove the probe from the first buffer solution, rinse it under distilled water and place it into the second buffer solution (4, 7, or 10 pH, different from the first buffer used). Press any key to continue.
6. Select the pH for the second buffer solution using the **CHANGE CHOICE** key, then press **ACCEPT**.

If the pH probe is damaged and cannot be calibrated or if the buffer solutions do not fall within an acceptable range, an error message will be displayed as shown below.

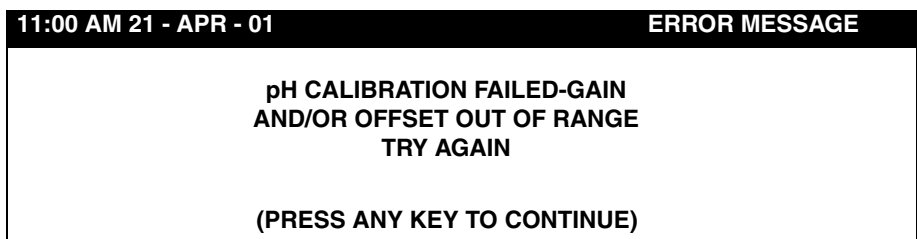

Another attempt at reading the second buffer solution will be made after pressing a key. If this fails, it is likely that you have a bad pH probe or bad buffer solutions. Try a new set of buffer solutions and if that fails try a different pH probe

### 5.3 ORP Probe

The probes are shipped with a wetting cap that covers the probe tip. Remove the cap by turning it counter-clockwise and gently easing it off. Keep this cap for long-term probe storage. Rinse the probe tip with distilled water.

Store the probe in a pH 4.0 buffer (Cat. No. 22834-49) for both overnight and long term storage. Never store a probe in distilled or deionized water because this will deplete the probe filling solution.

#### 5.3.1 ORP Probe Connection

This connector is for installing the pH or ORP pre-amp interface junction box or a stand-alone temperature sensor. The ORP probe is attached to a terminal strip in the junction box.

Table 9 ORP Connector Pin Assignments (J3)

Pin	Signal Description	Wire Color
A	+5 V dc	White
B	ground	Blue
C	reference	Yellow
D	pH/ORP	Black
E	5 V dc	Red
F	RTD	Green

The ORP probe consists of three wires; a pink, black, and red wire. There is no temperature sensor on the ORP probe.

1. Attach the clear wire to either screw on the terminal strip labeled GLASS.
2. Attach the black wire to the REF screw on the other terminal strip.
3. Attach the red wire to the GND screw on the terminal strip.

### 5.3.2 ORP Probe Programming

1. From the Main Menu, select **OPTIONS>ADVANCED OPTIONS>DATALOG**.
2. Highlight Select Inputs using the **UP** and **DOWN** keys and press **SELECT**.
3. Highlight ORP using the **UP** and **DOWN** keys, then press **SELECT**.
4. Press **CHANGE CHOICE** to cycle between Logged and Not Logged, then press **ACCEPT** to continue.
5. Enter a logging interval, then press **ACCEPT**. Valid logging intervals are shown on the status bar along the bottom edge of the display.
6. Select another channel to configure or press **RETURN** to back up one step. Press **MAIN MENU** to return to the Main Menu.

### 5.3.3 ORP Probe Calibration

#### 5.3.3.1 ORP Preamplifier/Junction Box Calibration

Calibration of the ORP input circuit requires a source of dc voltage between 500 and 2000 mV dc. The reference voltage must be applied to the ORP input terminals on the preamplifier/junction box during calibration. A regulated dc power supply or a standard "C" cell battery (1500 mV dc) make excellent sources for reference voltage.

1. From the Main Menu, select **OPTIONS > ADVANCED OPTIONS > CALIBRATION > ORP**.
2. Install the ORP junction box on the sampler with the ORP probe removed.
3. Apply a positive reference voltage to the ORP probe terminals in the junction box, using either a 1.5 V dc "C" cell battery or a regulated power supply.

4. Attach the positive battery terminal to the terminal block screw labeled "glass" and the negative battery terminal to the terminal block screw labeled "ref."
5. After making all connections, measure the exact voltage on the "C" cell or power supply with a voltmeter. Then press a key to continue. The sampler displays the message "Waiting for ORP to Stabilize."
6. Once the reading is sufficiently stable enter a new millivolt level. The "C" cell battery should be approximately 1500 mV (or 1.5 V) when new. Enter the exact voltage of the current source in millivolts.
7. Press **ACCEPT** to store the new calibration values.
8. Disconnect the "C" cell battery or regulated power supply from the ORP input terminals.
9. Reconnect the ORP Probe leads to the input terminals.

### 5.4 Dissolved Oxygen Probe

#### 5.4.1 Dissolved Oxygen Probe Connection

This connection is for interfacing the optional D.O. probe to the D.O./Conductivity Pre-Amp (Cat. No. 3369).

**Table 10 D.O. Connections (J20)**

Pin	Signal Description	Wire Color
A	DO - (neg)	Green
B	DO + (pos)	Red
C	Thermister	Black
D	Thermister	Yellow

#### **Strain Relief Recommendation**

A strain relief is recommended to protect the cable/probe junction during application where the sensor will be thrown or tossed into liquid.

#### 5.4.2 Dissolved Oxygen Probe Programming

**Note:** The *membrane thickness must be programmed into the instrument*. The instrument uses this information to determine if the sensor is generating a reasonable current. Failure to program this value may result in false error conditions

1. From the Main Menu, select **OPTIONS>ADVANCED OPTIONS>DATALOG**.
2. Highlight Select Inputs using the **UP** and **DOWN** keys and press **SELECT**.
3. Highlight D.O. using the **UP** and **DOWN** keys, then press **SELECT**.
4. Press **CHANGE CHOICE** to cycle between Logged and Not Logged, then press **ACCEPT**.
5. Enter a logging interval, then press **ACCEPT**. Valid logging intervals are shown on the status bar.
6. Press **CHANGE CHOICE** to select the appropriate units (ppm, ppb, mg/L, sat). Press **ACCEPT** to continue.
7. Select another channel to configure, press **RETURN** to back up one step or press **MAIN MENU** to return to the Main Menu.

### 5.4.3 Dissolved Oxygen Probe Temperature Programming

1. From the Main Menu, select **OPTIONS>ADVANCED OPTIONS>DATALOG**
2. Highlight Select Inputs using the **UP** and **DOWN** keys and press **SELECT**.
3. Highlight D.O. Temp. using the **UP** and **DOWN** keys, then press **SELECT**.
4. Cycle between Logged and Not Logged, then press **ACCEPT**.
5. Enter a logging interval using the numeric keypad, then press **ACCEPT**. Valid logging intervals are shown on the status bar.
6. Select temperature units (°C, °F) using **CHANGE CHOICE**. Press **ACCEPT**.

### 5.4.4 Dissolved Oxygen Probe Calibration

The Dissolved Oxygen Probe is shipped without an electrolyte or membrane installed. Install these items before initial use.

1. Connect a suitable power supply to the sampler, and power up the unit by pressing the **ON** button.
2. From the Main Menu, select **OPTIONS > ADVANCED OPTIONS > CALIBRATION > DO**.
3. Enter the ambient air temperature (the current reading is displayed for reference) using the numeric keypad.
4. Enter the elevation above sea level for the specific location.
5. Enter the membrane thickness. The operation of the sampler will be affected by membrane thickness for the oxygen sensor.

**Note:** *The membrane of a charged sensor must be kept moist. If the membrane is allowed to dry completely, the electrolyte film between the membrane and the platinum will evaporate, destabilizing the sensor. If the sensor will be out of water for more than 30 minutes, put a small amount of water in the silicon soaking cap, and install it over the protective guard. Lift the edge of the cap to break the seal as it is being removed. This will prevent a vacuum from forming inside the soaking cap while it is being removed which can result in the membrane becoming stretched.*

For general purpose applications, the 1-Mil membrane is standard. This membrane allows measurements in the 0 to 20 ppm range of dissolved oxygen and provides the best response time and durability.

The 2-Mil membrane can be used to measure up to 40 ppm dissolved oxygen. Its increased thickness slows the response time of the sensor, but this membrane has increased resistance to cuts and tears. For this reason, it is recommended for use in wastewater aeration basins where solids in the water are in rapid motion.

6. Enter the chlorinity (salinity) of the flow stream (typical wastewater is zero, sea water is higher).
7. Place the D.O. probe in open air and press any key. The sampler will wait for the reading to stabilize before storing the calibration value. The screen will automatically return to the calibration menu.

#### Calibrating the D.O. Temperature

1. Place the probe and the thermometer in a liquid.
2. Wait for the temperature reading to stabilize.
3. Enter the actual temperature of the liquid.

### 5.5 Conductivity Probe

#### 5.5.1 Conductivity Probe Connection

Table 11 Conductivity Probe Wiring (J20)

Pin	Signal Description	Wire Color
A	Probe	Black
B	Probe	Red
C	RTD	White
D	RTD	Green

#### 5.5.2 Conductivity Probe Programming

1. From the Main Menu, select **OPTIONS>ADVANCED OPTIONS>DATALOG**.
2. Highlight Select Inputs using the **UP** and **DOWN** keys. Press **SELECT**.
3. Highlight Conductivity (COND.) using the **UP** and **DOWN**. Press **SELECT**.
4. Press **CHANGE CHOICE** to cycle between Logged and Not Logged, then press **ACCEPT**.
5. Enter a logging interval using the numeric keypad, then press **ACCEPT**. Valid logging intervals are shown on the status bar along the bottom edge of the display.
6. Press **CHANGE CHOICE** to select the appropriate units (ms,  $\mu$ s). Press **ACCEPT** to continue.
7. Select another channel to configure or press **RETURN** to back up one step. Press **MAIN MENU** to return to the Main Menu display.

#### 5.5.3 Conductivity Temperature Programming

1. From the Main Menu, select **OPTIONS>ADVANCED OPTIONS>DATALOG**.
2. Highlight Select Inputs using the **UP** and **DOWN** keys and press **SELECT**.
3. Highlight Conductivity Temperature (COND. TEMP.) using the **UP** and **DOWN** keys, then press **SELECT**.
4. Press **CHANGE CHOICE** to cycle between Logged and Not Logged, then press **ACCEPT**.
5. Enter a logging interval using the numeric keypad, then press **ACCEPT**. Valid logging intervals are shown on the status bar along the bottom edge of the display.
6. Press **CHANGE CHOICE** to select temperature units ( $^{\circ}$ C,  $^{\circ}$ F). Press **ACCEPT**.

### 5.5.4 Conductivity Probe Calibration

1. From the Main Menu, select **OPTIONS > ADVANCED OPTIONS > CALIBRATION > CONDUCTIVITY**.
2. Clean and dry the probe.
3. Place the sensor and thermometer in the calibration solution (Cat. No. 3230). The temperature sensor is located in the middle of the sensor body allowing the probe to be completely submerged in the solution.
4. Allow the sensor to stabilize in the solution about 10 minutes to ensure that the probe and the solution are the same temperature.
5. Enter the temperature correction factor or enter zero for no correction factor.

**Note:** The temperature correction factor is used to compensate for the effects of temperature on the conductivity readings at the point of installation. The conductivity of a solution is temperature sensitive. Therefore the actual conductivity of the solution will change with the temperature. Each site may have a different correction factor depending on the major constituent of the flow stream. This is not used for calibration and has no effect on the calibration of the sensor. Below are some examples of compensation factors of various liquids.

- 0.96%/°C 5% Sulfuric Acid
  - 1.88%/°C Dilute Ammonia
  - 1.91%/°C 'Typical' Wastewater
  - **1.97%/°C Potassium Chloride**
  - 2.12%/°C Salt (Sodium Chloride)
  - 2.84%/°C 98% Sulfuric Acid
  - 4.55%/°C Ultra-pure Water
6. With the sensor still in the calibration solution, press any key. Wait for the sensor to stabilize. Calculate the actual conductivity of the calibration solution. If using the KCl solution provided by the manufacturer, make your selection from the [Table 12 on page 78](#). If using a solution other than 1.0 mS @ 25 °C KCl available from manufacturer, calculate the conductivity of the solution using temperature correction factors. See the following example.

**Example:** The KCl calibration solution is 1.0 mS at 25°C. If the actual temperature of the KCl at the time of calibration is 18.4 °C, then the solution has a conductivity value of 0.870 mS.

- a. Find the difference between the labeled temperature and the actual temperature of the calibration solution at the time of calibration.

$$25\text{ °C} - 18.4\text{ °C} = 6.6\text{ °C}$$

- b. Multiply the difference (6.6) by the correction factor per °C (1.97% or 0.0197).

$$6.6\text{ °C} \times 0.0197/\text{°C} = 0.13002$$

## Section 5

- c. If the calibration temperature is lower than the labeled value, then subtract that value from the standard (1.0 mS) to get the actual value to be used for calibration.

$$1.0 \text{ mS} - (\text{correction factor}) 0.13002 = 0.86998 \text{ mS}$$

- d. If the calibration temperature is higher than the labeled value, then add that value to the standard (1.0 mS) to get the actual value to be used for calibration.

7. Using the value that was calculated in step 6, enter the conductivity of the solution then press **ACCEPT** to complete the calibration.

### Calibrating the Conductivity Temperature

**Note:** Conductivity temperature calibration is only necessary when logging temperature.

1. Place the probe in a liquid and wait for the temperature reading to stabilize.
2. Enter the actual temperature of the liquid (the current reading is shown for reference). Temperature calibration is complete.

**Table 12 Conductivity Values at Temperature for Hach KCl Solution**

Solution Temp °C	Calibration Value to be Entered	Solution Temp °C	Calibration Value to be Entered	Solution Temp °C	Calibration Value to be Entered
30	1.099	25	1.000	20	0.902
29.8	1.095	24.8	0.996	19.8	0.898
29.6	1.091	24.6	0.992	19.6	0.894
29.4	1.087	24.4	0.988	19.4	0.890
29.2	1.083	24.2	0.984	19.2	0.886
29	1.079	24	0.980	19	0.882
28.8	1.075	23.8	0.976	18.8	0.878
28.6	1.071	23.6	0.972	18.6	0.874
28.4	1.067	23.4	0.968	18.4	0.870
28.2	1.063	23.2	0.965	18.2	0.866
28	1.059	23	0.961	18	0.862
27.8	1.055	22.8	0.957	17.8	0.858
27.6	1.051	22.6	0.953	17.6	0.854
27.4	1.047	22.4	0.949	17.4	0.850
27.2	1.043	22.2	0.945	17.2	0.846
27	1.039	22	0.941	17	0.842
26.8	1.035	21.8	0.937	16.8	0.838
26.6	1.032	21.6	0.933	16.6	0.835
26.4	1.028	21.4	0.929	16.4	0.831
26.2	1.024	21.2	0.925	16.2	0.827
26	1.020	21	0.921	16	0.823
25.8	1.016	20.8	0.917	15.8	0.819
25.6	1.012	20.6	0.913	15.6	0.815
25.4	1.008	20.4	0.909	15.4	0.811
25.2	1.004	20.2	0.905	15.2	0.807



Communication setup details connections and programming features of the:

- RS232 Serial Port ([section 6.1 on page 79](#))
- Optional Modem ([section 6.2 on page 80](#))
- 4–20 mA Option ([section 6.3 on page 87](#))
- Alarm Relays ([section 6.4 on page 89](#))
- Analog Inputs ([section 6.5 on page 93](#))

## 6.1 RS232 Cable

### 6.1.1 RS232 Connection

The RS232 connector is a serial input/output port for communicating with a sampler from an external device such as a Data Transfer Unit (DTU-II) or direct serial connection to a personal computer with application software.

**Table 13 RS232 Connection**

Pin	Signal Description	Wire Color
A	not used	White
B	ground	Blue
C	DSR	Yellow
D	RCD	Black
E	DTR	Red
F	TXD	Green

#### Cable Required

RS232 Sampler/Flow Meter to PC Cable Assembly (Cat. No. 1727), 10 ft long, 6-pin connector on one end, 9-pin D connector on the other end (9-pin to 25-pin D type adapter included).

### 6.1.2 RS232 Programming

**Note:** Some early generation IBM compatibles may have a serial port that is not capable of communicating reliably at 19,200 baud. If errors develop at high baud rates, try lowering the baud rate one step at a time (on both the sampler and Streamlogg II™, InSight®, or Vision® software) until error free communications is achieved.

1. From the Main Menu, select **OPTIONS > ADVANCED OPTIONS > COMMUNICATIONS SETUP > RS232 SETUP**.
2. Select a baud rate for data communications by pressing the **CHANGE CHOICE** key to cycle through the possible choices; 1200, 2400, 4800, 9600 or 19,200 baud. The higher the baud rate setting, the faster data will transfer. Set the baud rate to the highest setting allowed by the computer. The baud rate must correspond to the baud rate selected in the software. Press **ACCEPT**.

**Note:** Long runs of RS232 cable, especially if they are run near large motors or fluorescent lights can cause communication errors and may require a slower baud rate.

## 6.2 Modem

### 6.2.1 Modem Connection

This connection is for interfacing the optional internal modem (Cat. No. 1602) with a standard public telephone line.

**Table 14 Modem CPU Connections (J8)**

Pin	Signal Description
A	Tip
B	Ring
C	12 V dc
D	12 V dc Reference

### 6.2.2 Modem Programming

- From the Main Menu, select **OPTIONS>ADVANCED OPTION>COMMUNICATIONS SETUP**.

*Note: There is no way of independently enabling power to just the internal modem without also enabling the power to the Cellular Communications Option if it is present. However, this poses no problem even if the sampler is physically connected directly to a phone line without a cellular phone.*

- Highlight Modem Setup using the **UP** and **DOWN** keys. Press **ACCEPT**.

11:00 AM 21 - APR - 01		COMMUNICATION SETUP
SELECT		↑ ↓
	<b>MODEM SETUP</b>	
	RS232 SETUP	
RETURN		

- Enable modem power by pressing the **CHANGE CHOICE** key. Modem power is turned off when not in use to conserve battery power.

11:00 AM 21 - APR - 01		MODEM SETUP
ACCEPT		CHANGE CHOICE
	MODEM POWER: ENABLED	
CANCEL		
CHOICES: ENABLED, DISABLED		

4. Select either pulse or tone dialing modes. This will depend on the type of phone service selected for the site phone line. Press **ACCEPT**.

11:00 AM 21 - APR - 01		MODEM SETUP
ACCEPT	DIAL METHOD: TONE	CHANGE CHOICE
CANCEL		
CHOICES: TONE, PULSE		

5. Enter a phone number using the numeric keypad. This phone number is used by the modem when it sends an alarm report to a personal computer running InSight software.

11:00 AM 21 - APR - 01		MODEM SETUP
ACCEPT	INPUT CHANNEL: FLOW	CHANGE CHOICE
CANCEL		
(USE NUMERIC KEYPAD)		

### 6.2.2.1 Cellular Communication Option

**Note:** To ensure reliable communications between the sampler and the host computer, it is required that the host computer is equipped with a Cellular Compatible modem, it must support the MNP.10EC protocol. Computers equipped with modems that do not support this protocol are able to connect to the sampler but will not be able to maintain a reliable connection.

This option couples the sampler to an external, 3-watt, cellular phone. The cellular phone is mounted in a NEMA 4X enclosure and is powered through the sampler by the sampler power supply. Enabling Modem Power also provides power to the Cellular Communication via a connector cable.

The cellular phone is set to activate upon an alarm. Additionally, the end user can use the phone to make cellular voice calls directly from the installation site as needed.

#### Site Selection

The quality and availability of cellular service varies considerably from one geographical location and from day to day. Factors that affect the quality of cellular service include but are not limited to: weather, time of day, distance to the nearest cell tower, other cellular traffic, etc.

#### Installation and Setup

1. Connect the four conductor cable between the four pin connector on the side of the cellular phone housing and to the connector in the side of the sampler case labeled MODEM. This cable supplies both the data and the 12 V dc power for the cell modem.
2. Attach the magnetic base cell phone antenna to any flat metal object in the immediate area. For optimum performance, mount the antenna in a vertical position.

**Note:** Mount the antenna as high and as far away from the sampler as possible. RF power radiated during transmission by the cell phone antenna in close proximity to the sampler may have adverse affects on data measurements.

3. When necessary, reposition the antenna to obtain optimum signal strength.

**Note:** If the display on the cell phone is not present, check to make sure the cell phone power is enabled in the setup of the sampler. Also check to make sure that the sampler is connected to a power source and is turned on.

- Loosen the four screws on the cover of the cell phone enclosure and remove the cover, to view the signal strength. The signal strength is indicated by the number of dashes across the bottom of the cell phone display. The more dashes the greater the signal.

### 6.2.2.2 Reliable Communications

In order to ensure reliable communications between the sampler and the host computer, it is absolutely essential that the host computer is equipped with a Cellular Compatible modem. The modem on the host computer must support the "MNP.10ED" protocol. Computers equipped with modems that do not support this protocol may be able to connect to the sampler but will not be able to maintain reliable connections.

### 6.2.2.3 Cellular Modem Scheduling

With Cellular Modem Scheduling enabled, both the modem and cell phone power will simultaneously be turned off and on at user defined intervals to conserve battery power. If Cellular Modem Scheduling is disabled the sampler will assume that a land line is available and that the cell phone is not connected to the sampler. With Cellular Modem Scheduling disabled (and the sampler on battery power) the sampler will leave the modem turned off until a call is received on the land line.

**Note:** If the Cellular Modem Scheduling is disabled and the sampler is connected to a cell phone rather than a land line, the sampler will not be able to answer any incoming calls.

If the sampler is on ac power or the battery voltage is over 14.5 volts, the power to both the cell phone and modem will constantly be on regardless of whether Cellular Modem Scheduling is enabled or not.

If the sampler is configured to call a pager for alarms and the alarm condition is met, the sampler will still call the pager even if modem scheduling is disabled. In this situation the cell phone and modem will temporarily be powered back up again to allow the sampler to call the pager and transmit the alarm code. However, as soon as the alarm code is transmitted, the power to the cell phone and modem will again be turned off.

**Note:** If Modem Power is disabled, the Cellular Modem Scheduling prompt will not appear.

- To enable Cellular Modem Scheduling, Modem Power must be enabled.
- Enable the Cellular Modem Scheduling using the **CHANGE CHOICE** key.

11:00 AM 21 - APR - 01		MODEM SETUP
ACCEPT	CELLULAR MODEM SCHEDULING:	CHANGE CHOICE
CANCEL	ENABLED	
CHOICES: ENABLED, DISABLED		

- Press **ACCEPT** to continue.

### 6.2.2.4 Cellular Modem Scheduling Basis

After enabling Cellular Modem Scheduling it will be necessary to choose the type of scheduling; Hourly, Daily or Weekly. If Hourly is chosen the modem and cell phone are powered up once every hour on the hour for a user defined duration. If Daily is chosen the modem and cell phone are powered up once a day, every day, at a user defined time and duration. If Weekly is chosen the cell phone and modem are powered up only once a week, every week, on a user defined day, time, and duration.

1. To set the Cellular Modem Scheduling Basis press **CHANGE CHOICE** until the correct choice appears in the center of the display. Press **ACCEPT**.

11:00 AM 21 - APR - 01		MODEM SETUP
ACCEPT	CELLULAR MODEM SCHEDULING BASIS: DAILY	CHANGE CHOICE
CANCEL		
CHOICES: HOURLY, DAILY, WEEKLY		

2. Set up the actual time and duration when the modem will be enabled.
3. For Hourly, schedule the duration that the modem will be turned on.

11:00 AM 21 - APR - 01		MODEM SETUP
ACCEPT	CELLULAR SCHEDULING DURATION: 5 min.	
CANCEL		CLEAR ENTRY
ENTER: 1 - 59		

4. If Daily is selected enter the Cellular Scheduling Start Time and Duration.

11:00 AM 21 - APR - 01		MODEM SETUP
ACCEPT	CELLULAR SCHEDULING START TIME: 1:00 (hrs:min)	
CANCEL		CLEAR ENTRY
ENTER: 000:01 - 024:00 (hrs:min)		

5. If Weekly is selected, enter the Cellular Modem Schedule Day, Start time, and Duration.

11:00 AM 21 - APR - 01		MODEM SETUP
ACCEPT	CELLULAR MODEM SCHEDULE DAY: FLOW	
CANCEL		CLEAR ENTRY
CHOICES: MON, TUE, WED, THU, FRI, SAT, SUN		

## 6.2.2.5 Cellular Modem Triggering

When Cellular Modem Triggering is enabled both the cell phone and modem remains on for a user specified duration after calling a pager or remote computer when an alarm condition is met. It is useful when calling back to a site via modem, after receiving an alarm, or viewing the current status.

11:00 AM 21 - APR - 01		MODEM SETUP
ACCEPT	CELLULAR MODEM TRIGGERING:	CLEAR ENTRY
CANCEL	ENABLED	
CHOICES: ENABLED, DISABLED		

If Cellular Modem Triggering is disabled the sampler is still able to call a pager or remote computer when an alarm condition is met. However, both the modem and cell phone will immediately turn off after the call is completed.

### Cellular Modem Triggered Duration

After enabling Cellular Modem Triggering, enter a value for Cellular Modem Triggered Duration. This is the amount of time that the modem remains on after it dials a pager or remote computer when an alarm condition has been met. The value is in minutes and can be anywhere between 1 to 120 minutes.

11:00 AM 21 - APR - 01		MODEM SETUP
ACCEPT	CELLULAR MODEM TRIGGERING DURATION:	CLEAR ENTRY
CANCEL	30 min.	
ENTER 1 - 120		

*Note: This display will not appear unless Cellular Modem Triggering is enabled.*

## 6.2.2.6 Pager Option

The sampler can be set to call up to three individual pagers or a remote computer when an alarm condition has been met. The pager setup is an extension of the Modem Setup menus. To have the sampler call a pager, the Pager Option must be enabled.

1. Enable the Pager Option, using the **CHANGE CHOICE** key. Press **ACCEPT**.

11:00 AM 21 - APR - 01		MODEM SETUP
ACCEPT	PAGER OPTION:	CHANGE CHOICE
CANCEL	ENABLED	
CHOICES: ENABLED, DISABLED		

2. Enter the phone number of the paging service. Press **ACCEPT**.

11:00 AM 21 - APR - 01		MODEM SETUP
<b>ACCEPT</b>	<b>PAGER SERVICE</b> <b>PHONE NUMBER:</b> 555-5555	<b>CLEAR</b> <b>ENTRY</b>
<b>CANCEL</b>		
<b>(USE NUMERIC KEYPAD)</b>		

3. Enter the number of pagers to call when an alarm occurs. Press **ACCEPT**.

11:00 AM 21 - APR - 01		MODEM SETUP
<b>ACCEPT</b>	<b>NUMBER OF PAGERS:</b> 3	<b>CLEAR</b> <b>ENTRY</b>
<b>CANCEL</b>		
<b>ENTER 1 - 3</b>		

4. Enter the phone numbers of the individual pagers to send the message to. This is usually the phone number that is given to the pager when it is purchased. Press **ACCEPT**.

11:00 AM 21 - APR - 01		MODEM SETUP
<b>ACCEPT</b>	<b>PAGER #1</b> <b>PHONE NUMBER:</b> 555-5555	<b>CHANGE</b> <b>CHOICE</b>
<b>CANCEL</b>		
<b>CHOICES: ENABLED, DISABLED</b>		

### 6.2.2.7 Reporting Devices

The reporting order of the communication devices can be set to **MODEM ONLY**, **PAGER ONLY**, **PAGER THEN MODEM**, and **MODEM THEN PAGER**.

1. Press **CHANGE CHOICE** until the desired reporting method is displayed then press **ACCEPT**.

11:00 AM 21 - APR - 01		MODEM SETUP
<b>ACCEPT</b>	<b>REPORTING ORDER:</b> <b>PAGER THAN MODEM</b>	<b>CHANGE</b> <b>CHOICE</b>
<b>CANCEL</b>		
<b>CHOICES: MODEM AND / OR PAGER</b>		

When the sampler calls the pager service, it will transmit a Pager Alarm Code number (Table 15) which corresponds to a specific alarm condition.

## Section 6

**Table 15 Pager Alarm Codes**

Alarm	Code	Equipment	Reason	Alarm	Code	Equipment	Reason
Low Main Battery	1	—	Battery pack is less than 11.5 V	High CH5	28	—	—
Memory Battery	2	—	Internal memory battery is low	High CH6	29	—	—
Low Slate Memory	3	—	Less than 10% slate memory left	High CH7	30	—	—
Slate Memory Full	4	—	Slate memory is used up	High Reference Temp.	31	—	—
Modem Failure	5	—	Modem chip/modem board failure	High Velocity	32	—	—
Missed Sample	6	—	No liquid detected when sampling	High D.O.	33	—	—
Purge Failure	7	—	Water present at sensors after purge	High D.O. Temp.	34	—	—
Jammed Distributor	8	—	Sensors indicate arm is not moving	High Conductivity	35	—	—
Bottle is Full	9	—	Full bottle option indicator is on	High Cond. Temp.	36	—	—
U-Sonic Echo Loss	10	—	No return signal detected	Low Level	37	—	—
Xducer Ringing	11	—	The return signal is detected too soon	Low Flow	38	—	—
U-Sonic failure	12	—	Ultrasonic board detects an error	Low pH/ORP	39	—	—
RS485 Timed Out	13	—	Comm. problems with RS485	Low Process Temp.	40	—	—
Unable to Cool	14	AWRS only	Too high temperature in a compartment	Low CH1	41	—	—
Unable to heat	15	AWRS only	Too cold a temperature in compartment	Low CH2	42	—	—
Low Bubbler Pres.	16	(not applicable)	Possible leak in bubble tank	Low CH3	43	—	—
Clogged Bubbler	17	(not applicable)	Bubbler tube is plugged	Low CH4	44	—	—
High Level	18	—	—	Low CH5	45	—	—
High Flow	19	—	—	Low CH6	46	—	—
High Flow Rate of Chg.	20	—	—	Low CH7	47	—	—
High pH/ORP	21	—	—	Low Reference Temp.	48	—	—
High Process Temperature	22	—	—	Low Velocity	49	—	—
High Rainfall	23	—	—	Low D.O.	50	—	—
High CH1	24	—	—	Low D.O. Temp.	51	—	—
High CH2	25	—	—	Low Conductivity	52	—	—
High CH3	26	—	—	Low Cond. Temp.	53	—	—
High CH4	27	—	—				



## 6.3 4–20 mA Option

The 4–20 mA option provides a current loop for controlling external devices such as a chart recorder or PC. Either one or both of the 4–20 mA outputs can be factory installed and are isolated from each other.

### 6.3.1 4–20 mA Connection

The interface has a 3-ft cable with a connector on one end, and a 10-ft cable with two open wire leads on the other. Insert the connector into the sampler receptacle labeled “Auxiliary”, located on the left side of the control housing. On the 10-ft cable, the wire with clear insulation is positive (+) and the wire with black insulation is negative (-).

**Table 16 4–20 mA Connections (J18)**

Pin	Signal Description	Wire Color
A	Output 1 + (pos)	Yellow
B	Output 1 - (neg)	Black
C	Output 2 + (pos)	Red
D	Output 2 - (neg)	Green

#### Rating:

- Isolation Voltage:  
Between sampler and either 4–20 mA output: 2500 V ac  
Between the two 4–20 mA outputs: 1500 V ac
- Maximum Resistive Load: 600 ohm
- Output Voltage: 24 V dc - no load

#### Cable Required

4–20 mA Interface Cable (Cat. No. 2924), 25 ft long, 4-pin connector on one end, tinned wire leads on the other end.

### 6.3.2 4–20 mA Programming

**Note:** When the 4–20 mA outputs are disabled and not completely turned off, they will continue to output a steady 4 mA.

1. From the Main Menu, select **OPTIONS > ADVANCED OPTIONS > 4–20 mA OUTPUTS > SELECT**.
2. Enable the 4–20 mA outputs by pressing **CHANGE CHOICE** while in the 4–20 mA output menu.
3. When the display shows the outputs as enabled, press **ACCEPT**.
4. Choose either **OUTPUT A** or **OUTPUT B**. Use the **UP** and **DOWN** keys to highlight the choice, then press **SELECT**.

11:00 AM 21 - APR - 01		4–20 mA OUTPUTS
SELECT	OUTPUT A OUTPUT B	↑
RETURN		↓

5. Select an analog Input Channel (e.g., channel 1, 2, 3, or, flow, etc.) to assign to that output. Press **CHANGE CHOICE** to cycle through the channel names. When the desired channel is displayed, press **ACCEPT**.

11:00 AM 21 - APR - 01		4-20 mA OUTPUTS
ACCEPT	INPUT CHANNEL: FLOW	CHANGE CHOICE
CANCEL		
<b>SELECT APPROPRIATE UNITS</b>		

6. Assign a channel value to the 4 mA current value. This value is typically 0, however any value can be set. Enter the value of the input needed to generate 4 mA of current at the output.

11:00 AM 21 - APR - 01		4-20 mA OUTPUTS
ACCEPT	4 mA INPUT VALUE 0.00 mgd	CANCEL
CLEAR ENTRY		
<b>SELECT APPROPRIATE UNITS</b>		

7. Assign an input value to the 20 mA current level.
8. Repeat this process to configure the other 4-20 mA output.

### 6.3.3 4-20 mA Calibration

After wiring the 4-20 mA connection perform a 4-20 mA output calibration. The 4-20 mA output calibration requires a digital multimeter or access to the 4-20 mA current loop wiring. Two 4-20 mA outputs are available and are designated Output A and Output B. Both outputs are calibrated the same way and are isolated from each other.

Calibration may be performed while the 4-20 mA device is in the current loop, as shown in [Figure 24](#) or disconnected from the current loop as shown in [Figure 25](#). In either case, the multimeter must be set to a 20 milliamp dc range or greater.

1. From the Main Menu, select **OPTIONS > ADVANCED OPTIONS > CALIBRATION > 4-20 mA OUTPUTS**.
2. Connect a multimeter to the 4-20 mA current outputs per [Figure 24](#) and [Figure 25](#).
3. Make sure that the 4-20 mA output is enabled. If it is not enabled, press **CHANGE CHOICE** so that the display shows Enabled and press **ACCEPT**.
4. Select the output (A or B) to calibrate.
5. Press any key to set the selected output to 4.00 mA dc.
6. Measure the current on the selected output using the multimeter and enter the measured value using the numeric keypad. Press **ACCEPT**.

7. Press any key to set the output to 20.00 mA dc.
8. Measure the current on the selected output using the multimeter and enter the measured value using the numeric keypad. Press **ACCEPT** to complete the calibration.

By entering the measured current values, the microprocessor will electronically adjust the outputs to compensate for the difference between the measured values and the expected values.

**Figure 24** Calibration with the Meter in the Loop

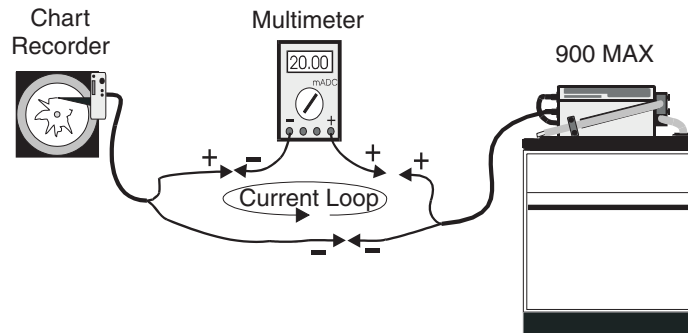

**Figure 25** Calibration with the 4–20 mA Device Disconnected from the Loop

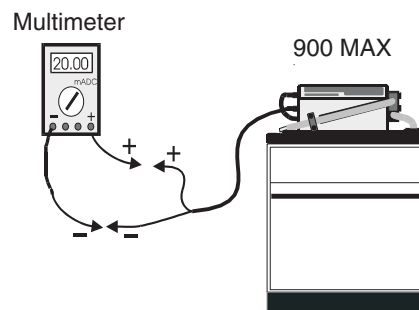

## 6.4 Alarm Relays

**Note:** Current to the relay contacts must be limited to 5 amps. A means to remove power from the relays locally in case of an emergency or for servicing the product must be provided by the user. This can be accomplished with an external switch and a 5-amp fuse or with a switched 5-amp circuit breaker.

Four alarm relay outputs are available as a factory installed option. The relays are mounted in an external NEMA 4X enclosure for installation to a wall or panel. Alarm contacts are rated for 10 amps at 240 V ac (resistive load).

The alarm wiring can be sized according to the load being used. The relay connector will accept wire sizes from 18–12 AWG with a rating of 300 V, 80 °C minimum. Do not use wire smaller than 18 AWG.

For relay pin assignments refer to [Table 17](#) and [Figure 26](#).

## Section 6

### 6.4.1 Alarm Relays Connection

**Table 17 Relay Connector (J17)**

Pin	Signal Description	Wire Color
A	+12 V dc	Red
B	Relay #1	Yellow
C	Relay #2	Black
D	Relay #3	Red
E	Relay #4	Green

**Figure 26 Relay Pin Connections**

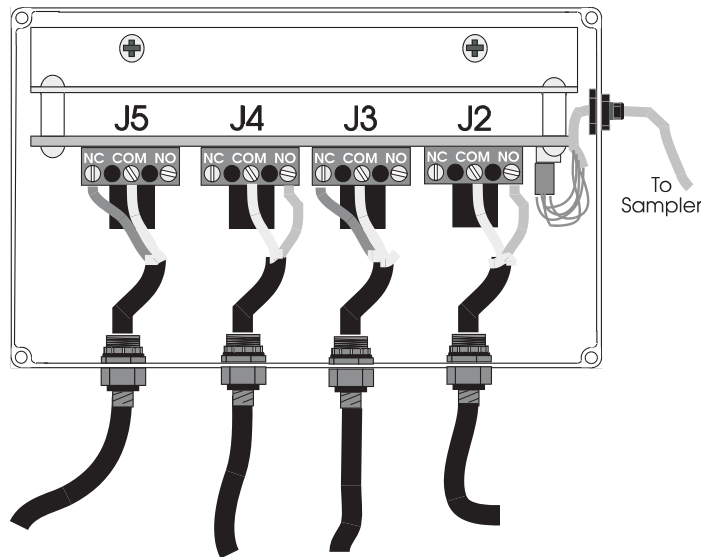

**Table 18 Relays**

Connector	Relay
J2	1
J3	2
J4	3
J5	4

#### Relay Junction Box

Required relay box is an alarm relay box assembly with a 10-ft long cable with a 6-pin connector on one end and a relay box on the other end (Figure 27).

1. Choose Normally Closed (NC) or Normally Open (NO) connections.
2. Connect one wire to the common (COM) and the other to the connector with the preferred signal.

**Figure 27** Single Relay Wiring Inside the Relay Junction Box

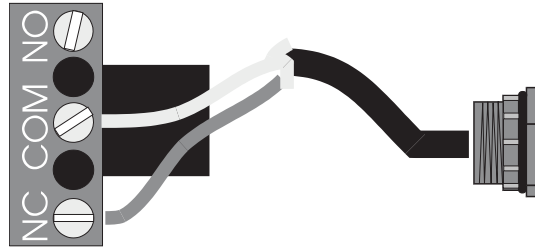

## 6.4.2 Alarm Relays Programming

Program alarms activate based on certain conditions (low battery, low memory, etc.). When an alarm is tripped, an action is initiated (report via modem, dial a pager, or set a relay). There are two types of alarms: Trouble Alarms and Set Point Alarms.

### 6.4.2.1 Trouble Alarms

Trouble Alarms initiate an action when a trouble condition occurs. For example, a relay may close when the memory is full. Refer to [Troubleshooting and Error Messages on page 127](#) for more information on trouble alarms.

1. From the Main Menu, select **SETUP > ADVANCED OPTIONS > ALARMS**.
2. Select one of the trouble conditions.
3. Select an action to occur when the alarm is activated. The table below lists each Trouble Condition. Refer to [Appendix C on page 127](#) for causes and solutions.

#### Trouble Conditions:

- Low Main Battery
- Low Slate Memory
- Modem Failure
- Purge Failure
- RS485 Timed Out
- Memory Battery
- Slate Memory Full
- Missed Sample
- Jammed Distributor

#### Alarm Actions:

- Set Relay #1
- Set Relay #3
- Report Via Modem
- Set Relay #2
- Set Relay #4

### 6.4.2.2 Set Point Alarms

Set Point Alarms look for trip points to be reached (either high or low or both) before initiating an action. For example an initiated action may be the closing of a relay when the water level exceeds 60 cm (24 in.) or drops below 10 cm (4 in.) Set Point Alarms activate when a user-definable high and/or low set point is reached.

1. Enable one of the alarm conditions.
2. Select an action to occur when the alarm is activated.
3. Set either a High trip point or a Low trip point.
4. After entering the trip point enter the deadband value. The deadband is the area between the alarm “turn on” and “turn off.”

*Note: Log rainfall to use an alarm on a rainfall condition; likewise, log flow in order to implement an alarm on a flow rate of change.*

### Set Point Alarm Conditions:

- Level
- Flow
- Flow Rate of Change
- pH
- ORP
- Process Temperature
- Rainfall
- Cabinet Temperature (refrigerated samplers)
- Analog Channels 1–3
- Analog Ch. 4 or D.O.
- Analog Ch. 5 or D.O. Temp.
- Analog Ch. 6 or Conductivity
- Analog Ch. 7 or Conductivity Temp.

*Note: Rainfall and Flow Rate of Change alarms are HIGH set point conditions; they take no deadband and they are time dependant.*

### Deadband

After entering the trip point, enter a deadband value. The deadband is the area between alarm “turn-on” and “turn-off”.

The purpose of setting the deadband is to eliminate alarm chatter which may occur if the “turn-on” and “turn-off” values are too close together. Small fluctuations occurring when the reading is at or near the trip point can rapidly toggle an alarm relay on and off.

In the pH example ([Figure 28](#)) the deadband is set to 0.10 pH. When the pH reached 6.9 (lower dashed line), the alarm tripped, but the alarm did not turn off until the pH came back up to 7.00. This difference is the deadband setting which should be set according to the characteristics of the item being measured.

Figure 28 Deadband Concept

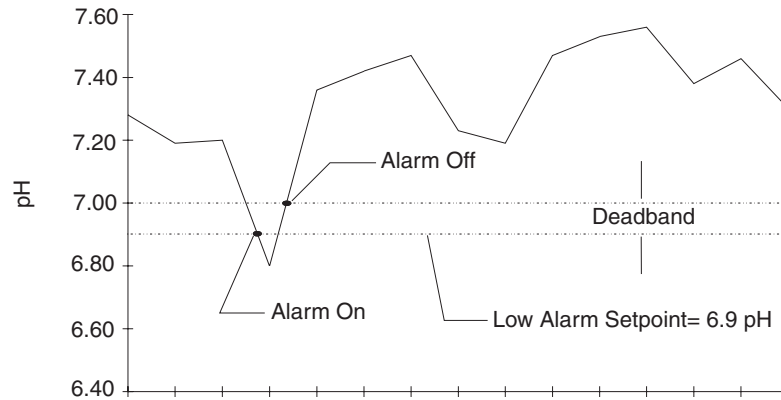

## 6.5 Analog Inputs

### 6.5.1 Analog Inputs Connection

**Note:** 4–20 mA inputs must be isolated. Maximum load per unit is 200 ohms.

Analog voltage as well as analog current input signals are accommodated in a single connector.

To connect the analog voltage signal (-4.0 to +4.0 V dc):

1. Tie ground wire to Pin B (ground).
2. Tie analog voltage wire to the appropriate voltage input pin (Pin C, E, or G).

For example, to connect an analog voltage input to analog input channel 1, tie the ground wire to pin B and your positive wire to pin C.

To connect an analog current signal (4–20 mA dc)

1. Tie ground wire to Pin B (ground).
2. Connect analog current wire to both voltage and current input pins for the appropriate channel (Pin C and D, or E and F, or G and H).

**Table 19** Analog Input Pin Assignments

Pin	Signal Description	Wire Color
A	+12 V dc	White
B	Signal Ground	Blue
C	Voltage Input 1 (-4.0 V dc to +4.0 V dc)	Yellow
D	Current Input 1 (4–20 mA dc)	Black
E	Voltage Input 2 (-4.0 V dc to +4.0 V dc)	Red
F	Current Input 2 (4–20 mA dc)	Green
G	Voltage Input 3 (-4.0 V dc to +4.0 V dc)	Gray
H	Current Input 3 (4–20 mA dc)	Brown
J	not used	Violet
K	not use	Orange

There are a total of three analog input channels available on the sampler. These inputs accept 4–20 mA dc or -4.0 to +4.0 V dc analog signals. They can be logged and graphed and can also be used to trigger alarms, cause setpoint samples, and control 4–20 mA outputs.

### 6.5.2 Analog Inputs Programming

Analog input channels can accept a signal from an external device. This signal may range from -4.0 V dc (min) to +4.0 V dc (max) or from 4 to 20 mA dc depending on the input selected. In some cases, input signals from certain devices may also fall somewhere within those ranges. For that reason, each analog input channel must be mapped to the minimum and maximum signal limits of the external device.

To map an external device to an analog input channel:

1. From the Main Menu, select **OPTIONS>ADVANCED OPTIONS>DATALOG**.
2. Highlight Select Inputs using the **UP** and **DOWN** keys and press **SELECT**.
3. Highlight the analog channel to log using the **UP** and **DOWN** keys, then press **SELECT**.
4. Press **CHANGE CHOICE** to cycle between Logged and Not Logged, then press **ACCEPT**.
5. Enter a Logging Interval using the numeric keypad. Press **ACCEPT** to continue.
6. Select Unit of measurement (ppm, ppb, afd, cfs, cfm, cfd, cms, cmm, cmh, cmd, gps, gpm, gph, lps, lpm, lph, or mgd).
7. Enter Low Point.
8. Enter High Point.
9. Select another channel to configure, or press **RETURN** to back up one step. Press **MAIN MENU** to return to the Main Menu display.

*Note: If logging is enabled on any channel, then that channel will have an arrow in front of the channel name to signify the channel is logged.*





## MAINTENANCE

### **DANGER**

*Some of the following manual sections contain information in the form of warnings, cautions and notes that require special attention. Read and follow these instructions carefully to avoid personal injury and damage to the instrument. Only personnel qualified to do so, should conduct the installation/maintenance tasks described in this portion of the manual.*

### **DANGER**

*Certains des chapitres suivants de ce mode d'emploi contiennent des informations sous la forme d'avertissements, messages de prudence et notes qui demandent une attention particulière. Lire et suivre ces instructions attentivement pour éviter les risques de blessures des personnes et de détérioration de l'appareil. Les tâches d'installation et d'entretien décrites dans cette partie du mode d'emploi doivent être seulement effectuées par le personnel qualifié pour le faire.*

### **PELIGRO**

*Algunos de los capítulos del manual que presentamos contienen información muy importante en forma de alertas, notas y precauciones a tomar. Lea y siga cuidadosamente estas instrucciones a fin de evitar accidentes personales y daños al instrumento. Las tareas de instalación y mantenimiento descritas en la presente sección deberán ser efectuadas únicamente por personas debidamente cualificadas.*

### **GEFAHR**

*Einige der folgenden Abschnitte dieses Handbuchs enthalten Informationen in Form von Warnungen, Vorsichtsmaßnahmen oder Anmerkungen, die besonders beachtet werden müssen. Lesen und befolgen Sie diese Instruktionen aufmerksam, um Verletzungen von Personen oder Schäden am Gerät zu vermeiden. In diesem Abschnitt beschriebene Installations- und Wartungsaufgaben dürfen nur von qualifiziertem Personal durchgeführt werden.*

### **PERICOLO**

*Alcune parti di questo manuale contengono informazioni sotto forma d'avvertimenti, di precauzioni e di osservazioni le quali richiedono una particolare attenzione. La preghiamo di leggere attentivamente e di rispettare quelle istruzioni per evitare ogni ferita corporale e danneggiamento della macchina. Solo gli operatori qualificati per l'uso di questa macchina sono autorizzati ad effettuare le operazioni di manutenzione descritte in questa parte del manuale.*



## **DANGER**

*Always disconnect power to the sampler before performing any maintenance or service.*

## **DANGER**

*Débranchez toujours l'alimentation de l'analyseur d'échantillonneur avant de procéder à un entretien ou une réparation.*

## 7.1 Cleaning the Sampler

### 7.1.1 Cleaning the Sampler Cabinet

Clean the interior and exterior of the sampler cabinet with a damp sponge and mild detergent. Do not use abrasive cleaners.

### 7.1.2 Cleaning the Sample Bottles

Clean the bottles using a brush and water with a mild detergent, followed by a fresh water rinse and a distilled water rinse. Glass bottles may also be autoclaved.

### 7.1.3 Cleaning the Intake Tubing and Pump Tubing

Clean the tubing by pumping water with mild detergent or other cleaning solution through the tubing, using the peristaltic pump in Manual Pump Mode. Press **MANUAL MODE**.

### 7.1.4 No Lubrication Required

The sampler **does not** require routine lubrication. Do not lubricate the pump tube with petroleum jelly, silicone grease, oil, or any other lubricant, as this will substantially reduce the life of the pump tube and roller assembly.

## 7.2 Pump Tubing Maintenance

### **DANGER**

*Always disconnect power to the sampler before removing the pump cover.*

### **DANGER**

*Débranchez toujours l'alimentation de l'analyseur d'échantillonneur avant de déposer le couvercle de la pompe.*

Replacement pump tubing is available from the manufacturer in 15' bulk length (Cat. No. 4600-15), and 50' bulk length (Cat. No. 4600-50). Use of tubing other than that supplied by the manufacturer may cause excessive wear on mechanical parts and/or poor pump performance.

### 7.2.1 Tubing Life Estimates

Pump tubing life depends on several factors:

- Distance from sample source. Locate the sampler as close to the sample source as possible.
- Vertical lift. Minimize the vertical lift (ideally, 15 feet or less).
- Intake Rinses. Minimize the number of intake rinses prior to sample collection.
- Pump roller assembly condition. Remove (clean) the silicone residue in the interior of the pump housing and on the rollers before installing a new tube.
- Constituents in the sample liquid. Grit and other abrasive solids cause greater wear on the tubing as they are squeezed through the pump rollers.

## Section 7

**Note:** To extend the life of the tubing, rotate the pump tube 90 degrees in the pump housing after approximately 2/3 of the life has been realized (once the tube life has been determined through use).

Experience at a particular site will be your best indicator of tubing life. Visually inspect the tubing and rollers on a regular basis after initial installation to get a feel for what maintenance your site will require. Be sure to replace the pump tubing before it splits to prolong the life of the sampler and keep the work area free of contamination from the sample liquid.

The proper length of silicone tubing must be used in the pump body. An improper length can reduce the life of the tubing and pump rollers. Refer to [Figure 29](#) for the correct length.

**Figure 29 Pump Tube Loading**

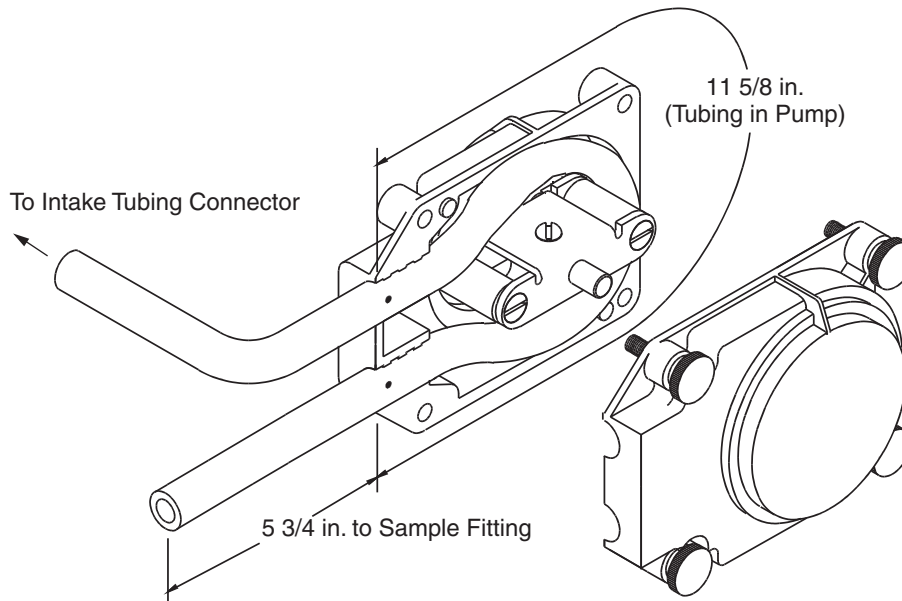

### 7.2.2 Replacing Pump Tubing

1. To replace the pump tube, remove the four screws on the pump cover.
2. Remove the front cover of the pump housing.
3. Remove the existing tubing. Locate the black dot on the new tubing. The end of the tube that extends farthest beyond the black dot attaches to the stainless steel tubing connector.
4. Install the pump tube in the pump housing until the black dots are visible just outside the pump body.
5. After inserting the new pump tube, reinstall the front cover and secure it with the four screws until finger tight.

### 7.3 Upgrades, Repairs, General Maintenance

Only a qualified technician should service the sampler. For example, steps that require knowledge of CMOS electrostatic discharge precautions and advanced electronics training and should only be performed by a qualified technician. If you need assistance in performing any of the following service steps, contact the manufacturer.



## Electrostatic Discharge (ESD) Considerations

**To minimize ESD risks, maintenance procedures not requiring power to the sampler should be performed with power removed.**

Delicate internal electronic components can be damaged by static electricity, resulting in degraded instrument performance or eventual failure.

The manufacturer recommends taking the following steps to prevent ESD damage to your instrument:

- Before touching any instrument electronic components (such as printed circuit cards and the components on them) discharge static electricity from your body. This can be accomplished by touching an earth-grounded metal surface such as the chassis of an instrument, or a metal conduit or pipe.
- To reduce static build-up, avoid excessive movement. Transport static-sensitive components in anti-static containers or packaging.
- To discharge static electricity from your body and keep it discharged, wear a wrist strap connected by a wire to earth ground.

Handle all static-sensitive components in a static-safe area. If possible, use anti-static floor pads and work bench pads.

### 7.4 Internal Maintenance Items

The following items require access to the inside of the case for service:

- Fuses for the RS485 and analog interface connectors (if equipped)
- Internal desiccant module
- RAM memory batteries
- System upgrades (4–20 mA, modem, alarm relays, etc.)
- Circuit board repair

### 7.5 Removing and Opening the Controller

#### **CAUTION**

**Always power the unit OFF and then disconnect all cables from the sampler before removing the controller.**

#### **ATTENTION**

**Débranchez toujours l'alimentation de l'analyseur d'échantillonneur et débranchez tous les câbles de l'analyseur avant de déposer l'unité de commande.**

To remove the controller from the refrigerator:

1. Turn the unit off by pressing the **OFF** key.
2. Disconnect and remove all cables to the controller housing, including the distributor/full bottle shutoff cable.
3. Disconnect all tubing.
4. Remove the two refrigerator mounting screws from the inside of the refrigerator.
5. Carefully lift the controller assembly up and off the refrigerator.

To open the controller:

1. Remove the 17 screws from around the perimeter of the controller back panel.
2. Carefully pull open the bottom panel and let the attached connectors swing out of the way.
3. If necessary for the repair being performed, unplug the appropriate connectors. Always note each connector location before unplugging anything. **Re-installing a plug into the wrong connector can cause extensive damage.**

**Note:** The front panel gasket has a light coating of grease to help ensure a watertight seal. Do not contaminate the grease or gasket area with dirt or debris during servicing. Always replace the gasket if it is damaged or missing. Never reassemble the case without the gasket properly installed.

### 7.6 Re-installing the Bottom Panel

**Note:** Always follow the procedure below when re-installing the sampler bottom panel. Improper panel installation may result in damage to the instrument.

1. Hand tighten each nut until it makes contact with the panel.
2. Tighten the nuts in sequence shown in [Figure 30](#) to 5 in.-lb (0.56 N-m).
3. Repeat the tightening procedure in the same sequence to 10 in.-lb (1.13 N-m).

**Figure 30** Tightening the Nuts on the Bottom Panel

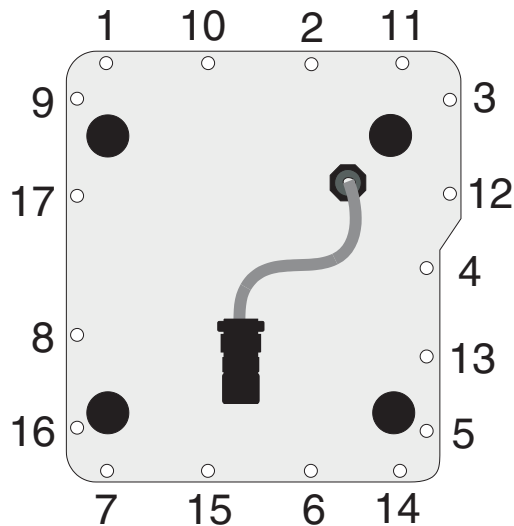

## 7.7 Circuit Board Identification

There are two main circuit boards in the sampler; the Utility Board and the CPU board. The CPU board is attached to the bottom panel and the Utility board is located inside the control housing behind the motor/gearbox assembly.

**Note:** Removal and handling of the circuit boards used in the sampler requires knowledge of ESD (Electro-Static Discharge) precautions and the CMOS (Complementary Metal-Oxide Semiconductor) circuit components used in the sampler. Static electricity has the potential to damage the CMOS components of the sampler when the boards are unplugged and removed from the case. Precautions must be taken to assure static-free personnel and work area prior to handling the circuit boards.

**Figure 31 CPU Board**

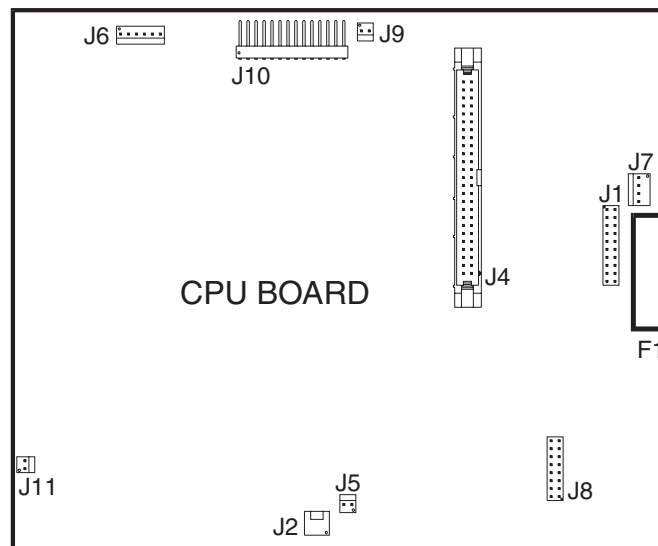

**Table 20 CPU Board Connectors**

ID	Description	ID	Description
J1	Liquid Crystal Display	J7	RS485 Submerged Pressure Transducer
J2	Mechanical Totalizer	J8	Modem Option Module
J3	not used	J9	Liquid Crystal Display (LED back-light)
J4	Base Board	J10	Keypad
J5	Memory Backup Battery Pack	J11	not used
J6	RS232 Serial Port		

Figure 32 Utility Board

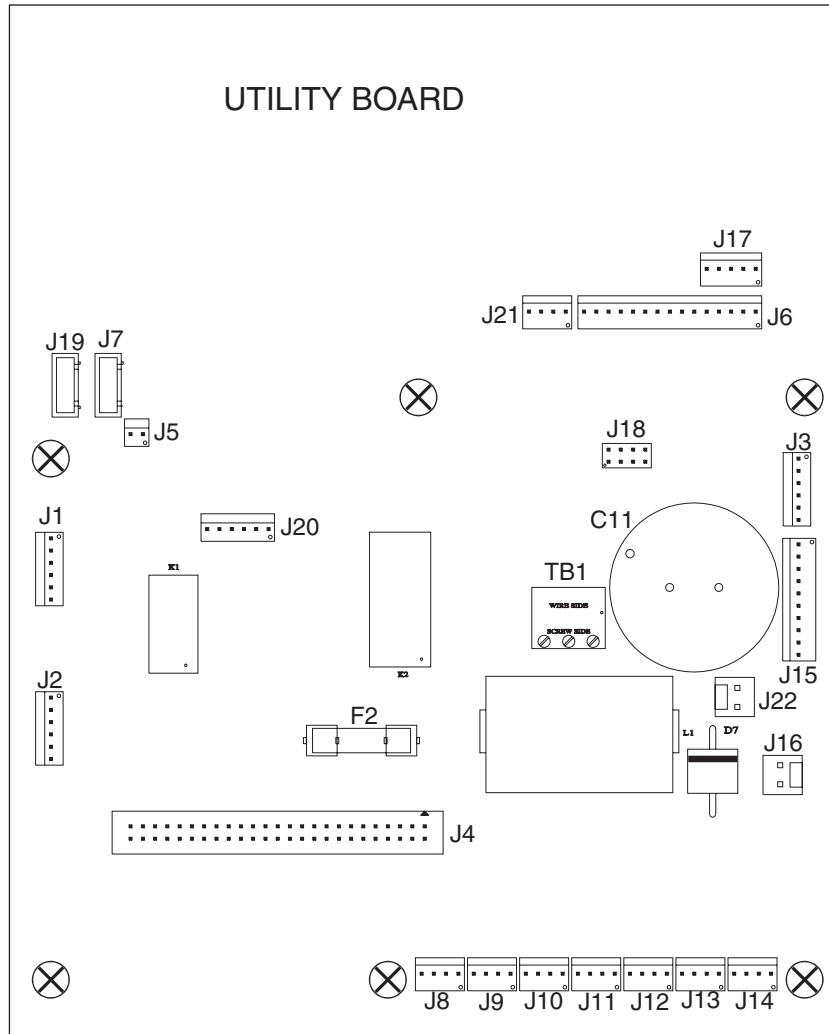

Table 21 Utility Board Connections

ID	Description	ID	Description
J1	Distributor	J12	Analog Input Channel 5
J2	Auxiliary	J13	Analog Input Channel 6
J3	pH/ ORP	J14	Analog Input Channel 7
J4	CPU Board	J15	Thermal Control
J5	Rain Gauge	J16	12 V dc Main
J6	Bubbler Module	J17	Relay Output
J7	Fluid Sensor #1	J18	4–20 mA PCB
J8	Analog Input Channel 1	J19	Fluid Sensor #2 (closest to pump)
J9	Analog Input Channel 2	J20	D.O. / Conductivity
J10	Analog Input Channel 3	J21	Submerged Sensor
J11	Analog Input Channel 4	J22	5 amp External Fuse



## 7.8 Replacing the Fuse

### **DANGER**

*For continued protection against fire, replace fuses with only fuses of specified type and current rating.*

### **PELIGRO**

*Para una continua protección contra incendios, reemplace los fusibles únicamente por los del tipo y capacidad recomendados.*

### **Medium Delay Fuse, 5 Amp**

The main 12 volt line is fused as soon as it enters the controller housing. This is a 5-amp medium delay fuse (Cat. No. 8753) and is accessible from outside the case on the back side of the controller housing. To remove the fuse unscrew the cap on the fuse holder with a flat blade screwdriver.

### **PCB Fuse Removal and Inspection**

Pull the fuse straight out of the holding clips to remove the fuse. The wire strand inside the glass tube will be broken. Use an ohmmeter to tell for sure if a fuse needs to be replaced.

## 7.9 Motor/Gear Box

The motor/gear box requires no regular maintenance. The special formulation gears are self lubricating and require no oil or grease.

## 7.10 Internal Desiccant Module

**Note:** *The desiccant module cannot be recharged by heating. Do not attempt to bake the desiccant module in an oven to remove the moisture as this could be a fire hazard.*

The Internal Desiccant Module (Cat. No. 8849) consists of a moisture-absorbent material inside a poly bag. If the humidity indicator on the front panel turns pink, replace the module and the back panel perimeter gasket (Cat. No. 8606). The desiccant module is located under the CPU board.

### 7.10.1 Replacing the Desiccant

To replace the desiccant, detach the controller from the refrigerator cabinet, and remove the screws from the controller bottom panel. Remove the desiccant bag and replace with a new one. Replace the controller gasket and cover plate. Reattach the controller to the refrigerator. After replacing the desiccant module and re-sealing the case, the Internal Case Humidity Indicator Disc (Cat. No. 2660) should return to its original blue color. If the humidity indicator is blue the desiccant is dry. Replace the indicator disc if it fails to return to blue after replacing the desiccant module. To replace the indicator disc, remove the bottom panel that is held in place by a small clip and screw.

### 7.11 Memory Battery

Random Access Memory (RAM) is a very reliable data storage medium for microprocessor applications. However, RAM requires power at all times. If power is removed, the data stored in the RAM chip is lost. Therefore, RAM chips cannot be powered from the sampler power supply because data and program settings would be lost every time the power cord was unplugged. A separate battery located inside the sampler controller is provided to power the RAM chips and the real-time clock. The memory battery keeps the program entries and logged sample data alive inside the RAM memory when the main power fails or is removed for transport or replacement.

The sampler memory battery consists of two "C" cell alkaline batteries.

Should the memory battery voltage fall too low to properly maintain the program settings, a warning: **MEMORY POWER LOW** will alert to replace the battery. The sampler utilizes a very small amount of energy from the memory battery during normal operation. The service life of the batteries in this application is typically five years.

For best results, read the instrument manual before beginning. Use this guide as a reminder.

## Sigma 900 MAX Refrigerated Sampler Main Menu Flow Chart

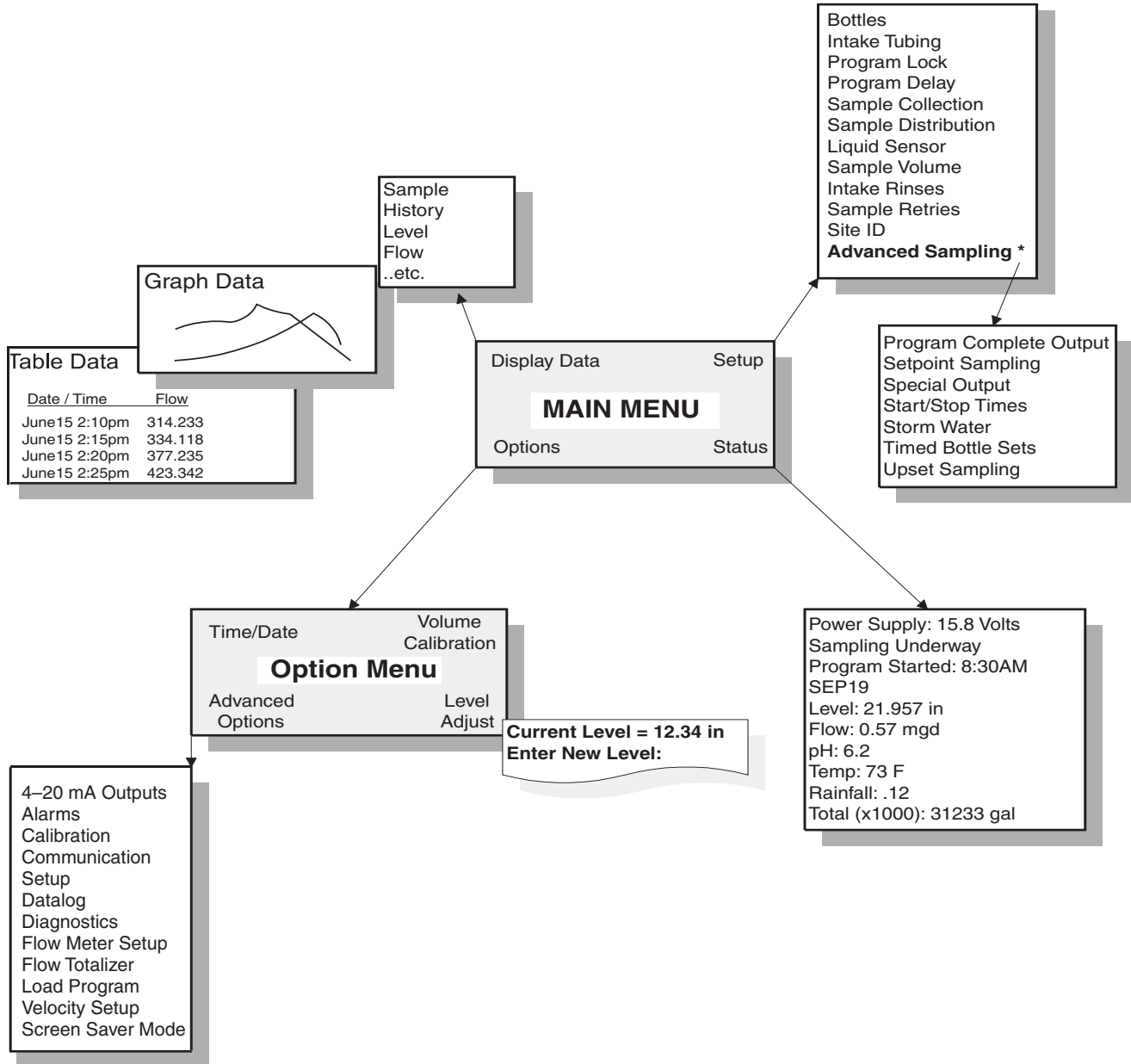

# Sigma 900 MAX Refrigerated Sampler Setup Flow Chart

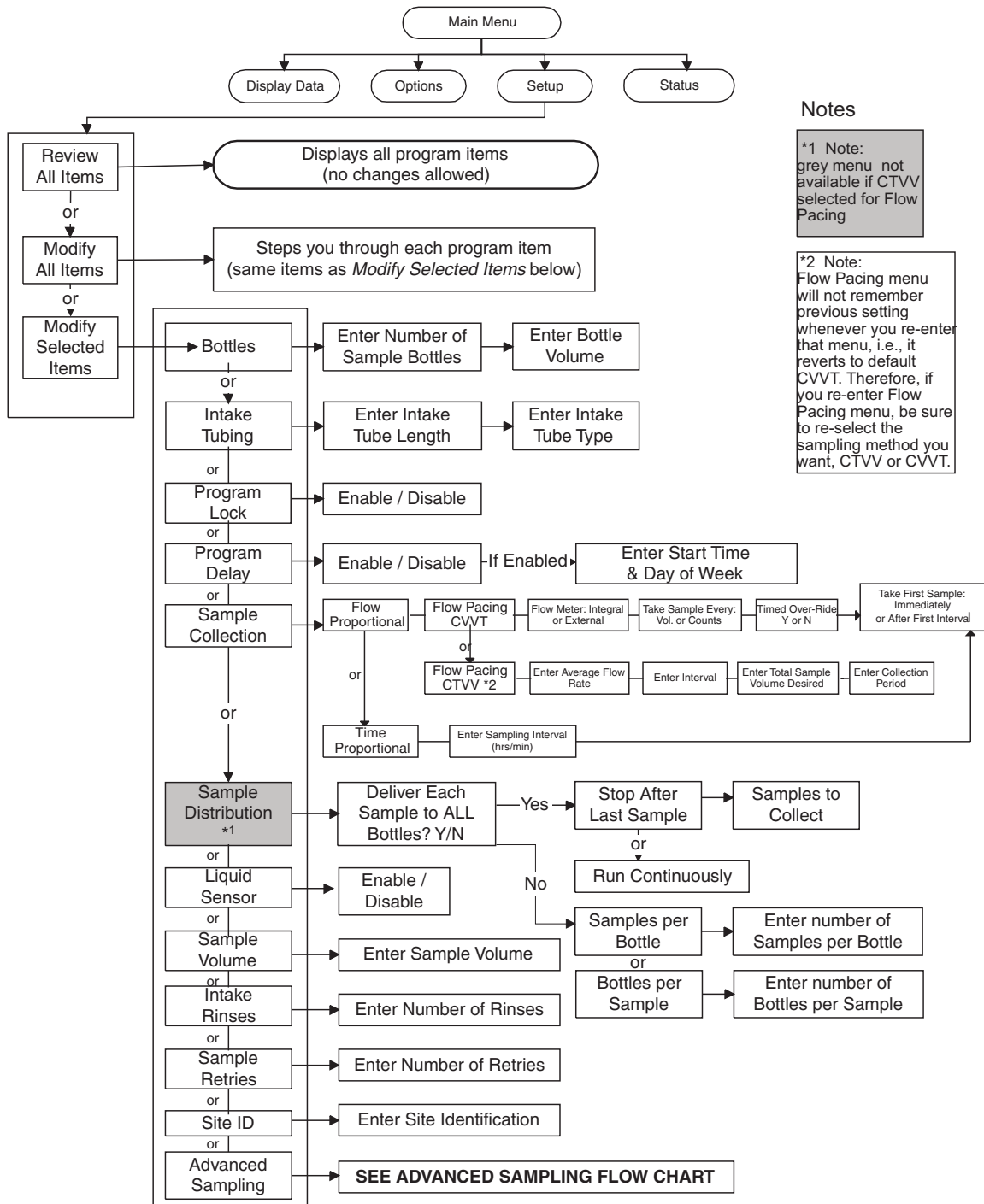

**Notes**

\*1 Note: grey menu not available if CTVV selected for Flow Pacing

\*2 Note: Flow Pacing menu will not remember previous setting whenever you re-enter that menu, i.e., it reverts to default CVVT. Therefore, if you re-enter Flow Pacing menu, be sure to re-select the sampling method you want, CTVV or CVVT.

# Sigma 900 MAX Refrigerated Sampler Options Flow Chart

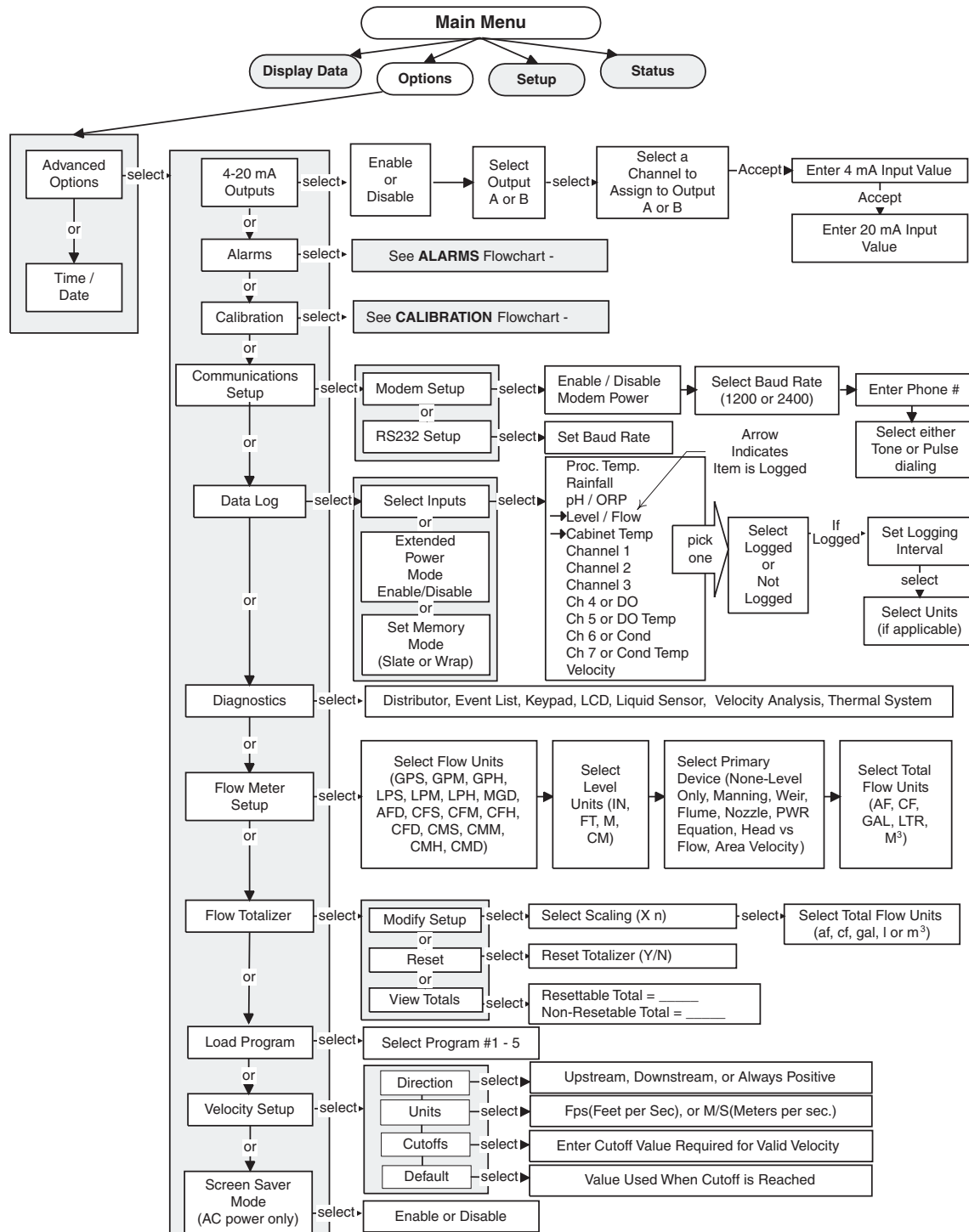

# Sigma 900 MAX Refrigerated Sampler Advanced Sampling Flow Chart

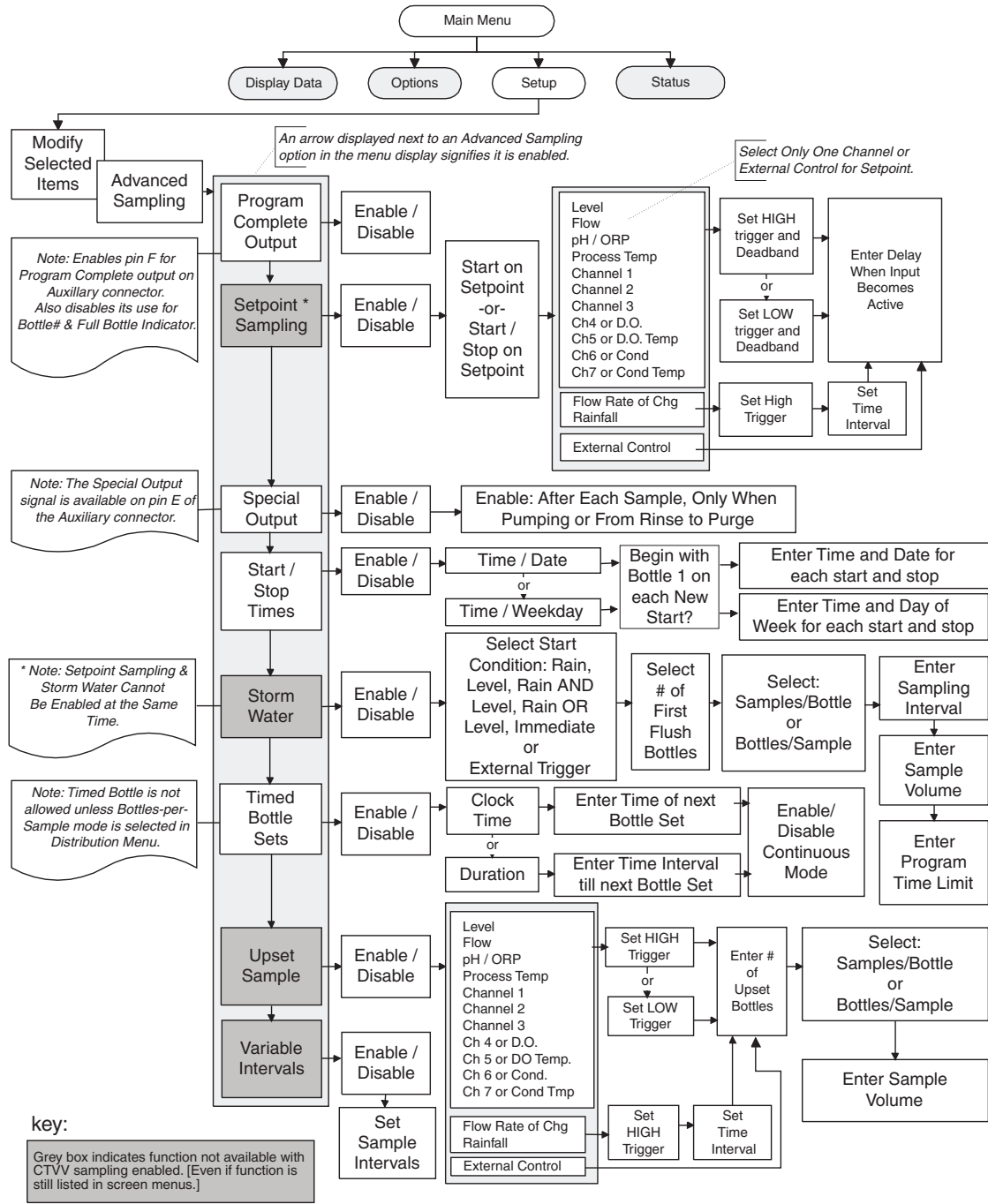

# Sigma 900 MAX Refrigerated Sampler Alarms Flow Chart

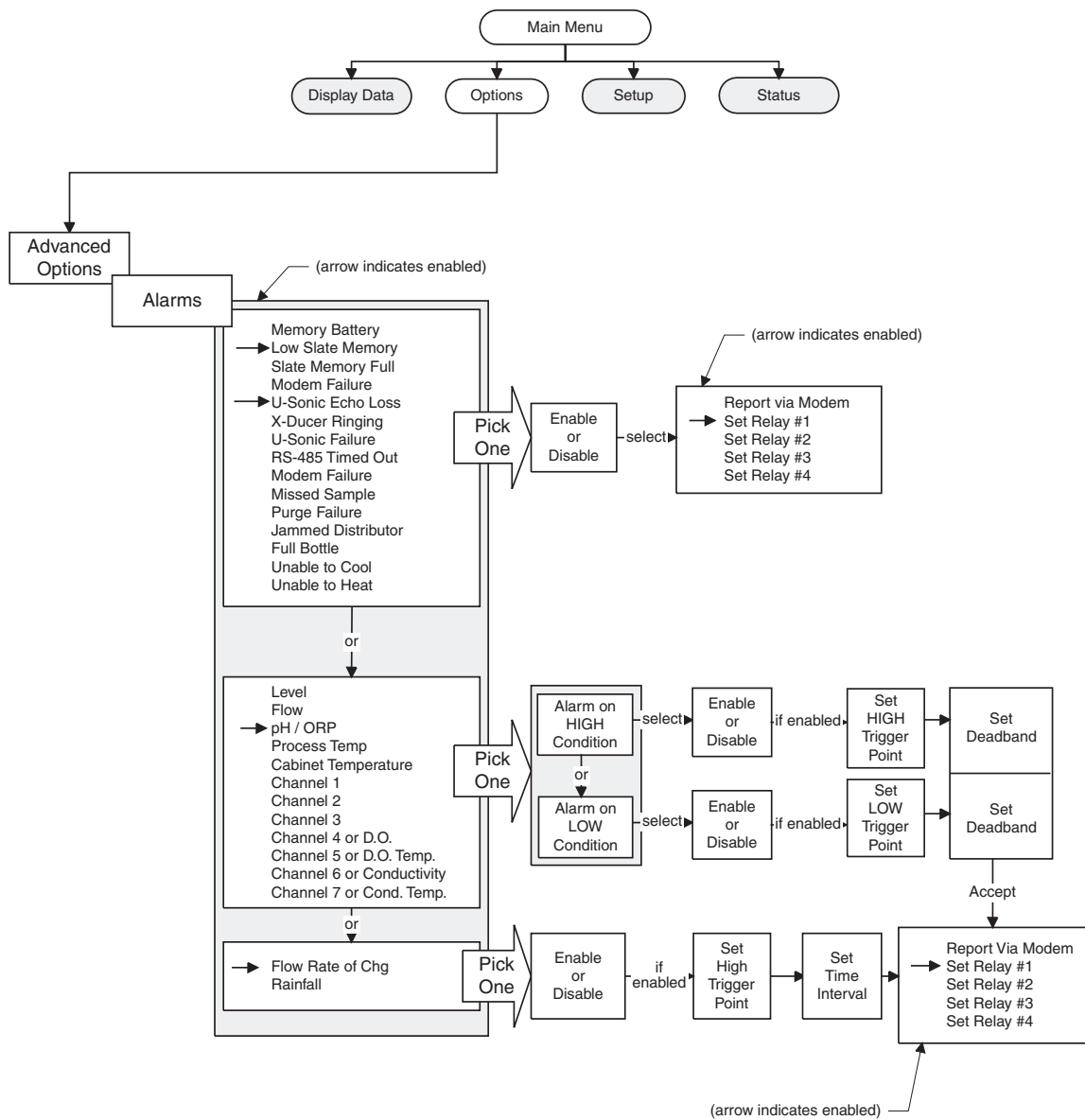

Sigma 900 MAX Refrigerated Sampler Calibration Flow Chart (1 of 2)

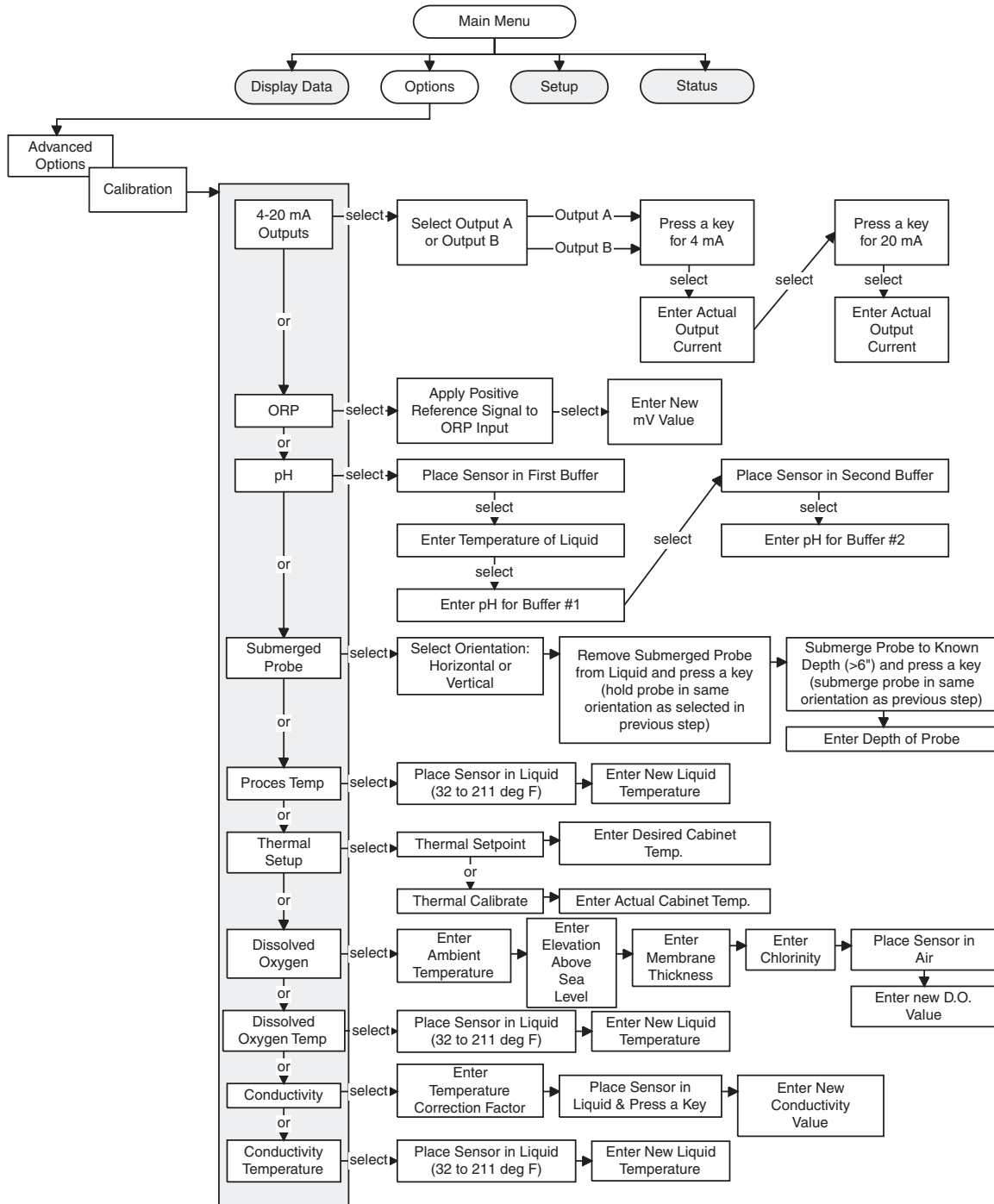



# Sigma 900 MAX Refrigerated Sampler Calibration Flow Chart (2 of 2)

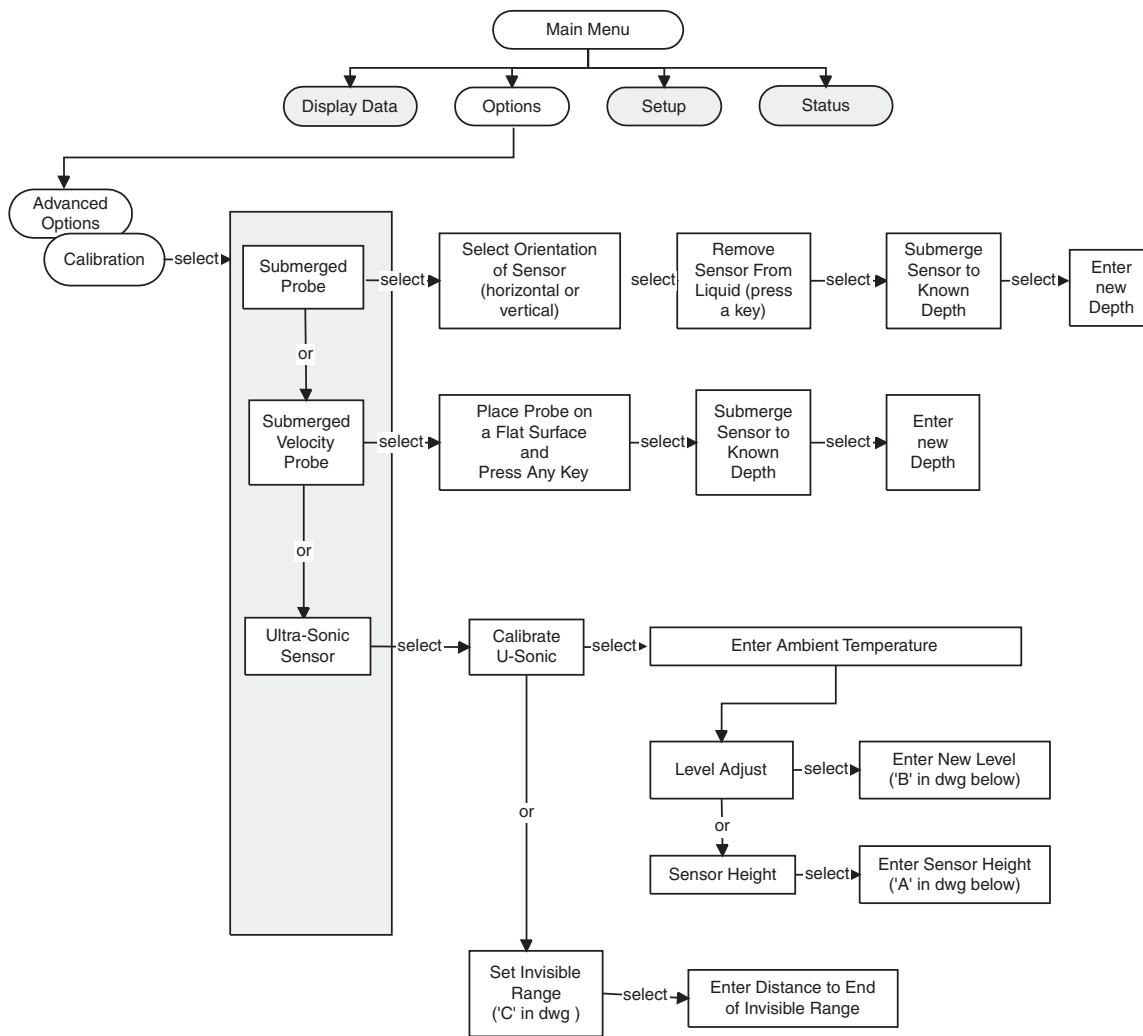



## Review All Items

This function reviews all information in the Setup and Option menus without worrying about accidentally changing the information. Use this function to verify that the program is set up properly.

All program entries and the status of all logged channels are displayed. Since this information fills more than one screen, scroll through the setup information one page at a time with the arrow keys.

11:00 AM 21 - APR - 01		SETUP REVIEW
900 MAX VERSION:	1.00	
NUMBER OF BOTTLES:	4	
BOTTLE VOLUME:	10.00 gal	
INTAKE TUBE LENGTH	50 ft	
INTAKE TUBE TYPE	3/8" VINYL	
PROGRAM LOCK	OFF	↓

When you get to the last screen an **UP** key will be displayed. Scroll back up the list or press **MAIN MENU** to exit.

11:00 AM 21 - APR - 01			SETUP REVIEW
CHANNEL 3	ppm	NOT LOGGED	1min
CHANNEL 4	ppm	NOT LOGGED	1min
CHANNEL 5	ppm	NOT LOGGED	1min
CHANNEL 6	ppm	NOT LOGGED	1min
CHANNEL 7	ppm	NOT LOGGED	1min
MEMORY MODE	WRAP		↑

When you are satisfied that all program entries are set up properly, press **MAIN MENU** to exit this screen and return to the main menu.

### Review All Items Screen Contents

The first line of the Setup Review screen shows the software revision level for the internal embedded software (firmware) of the sampler and should be noted before calling the factory.

## Running a Program

**Note:** When selecting Start from Beginning, all logged data will be cleared from memory. If this data needs to be saved make sure it is downloaded to a DTU or personal computer prior to pressing **START FROM BEGINNING**.

To run or halt a program, press the **RUN/STOP** key on the front panel. If the program has been stopped (and no changes to the program settings were made while it was stopped), pressing the **RUN** key will cause the program to ask to resume the previously running program (and retain all logged data) or **START FROM BEGINNING** (and clear all logged data).

## Displaying Data

The Display Data function provides the recorded data for any channel being logged in a tabular report or a graph.

In addition, for tabular reports, the data can be viewed from the beginning, from the end, or from a specific point in time. A graph can display any 24-hour period, zoom in to any portion of the 24-hour period for finer detail, or center the graph on a specific point in time.

## Selecting the Channel

**Note:** Only the channels for which logging has been enabled will be listed.

1. Press **DISPLAY DATA** from the Main Menu to display a list of logged channels.
2. Highlight the desired channel using the **UP** and **DOWN** keys then press **SELECT**.

11:00 AM 21 - APR - 01		DISPLAY DATA
SELECT	FLOW	↑
	<b>RAINFALL</b>	
PH		
RETURN		↓

## Tabular or Graph Format

1. Highlight the desired display method using the **UP** and **DOWN** keys then press **SELECT**.

11:00 AM 21 - APR - 01		DISPLAY DATA
SELECT	DISPLAY DATA	↑
	<b>DISPLAY BY GRAPH</b>	
RETURN		

**Table 22 Display Data Functions and Descriptions**

Function	Description
<b>Display Data by Table</b>	
	<b>View from start:</b> Displays the data for the selected channel beginning with the first (oldest) data point in memory.
	<b>View from end:</b> Displays the data for the selected channel beginning from the most recent point in memory.
	<b>View from time/date:</b> Displays the data for the selected channel beginning from any desired time and date. Enters a new desired time and date.
	<b>Note:</b> Totals displayed are calculated by summing the logged data. If the date selected precedes available logged data (memory has wrapped), the total will be incorrect.
<b>Display Data by Graph</b>	
	<b>Graph day:</b> Displays data for a specified date. Data for the selected date is graphed from midnight to midnight.
	<b>Graph point in time:</b> Displays data for a specified time and date. The graph displays three hours of data with the selected point in the time at the corner of the graph.
	<b>Graph partial day:</b> Zooms in on a portion of the logged data.

## Graph Manipulation

**Table 23 Graphing Functions and Descriptions**

Functions	Description
<b>Status Bar</b>	
	Displays the time, date, measured value, and unit of measure at the intersection of the data cursor. Placing the cursor's data on the status bar eliminates the need for X or Y axis labels and provides a larger graph viewing area.
<b>Moving the Data Cursor with the Arrow Keys</b>	
	The data cursor appears as a vertical line in the center of the graph. Move the data cursor to the left or right by using the soft keys or the numeric keypad.
<b>Moving the Data Cursor with the Numeric Keypad</b>	
	The keys 0–9 represent a percentage of full scale. Pressing a numeric key on the keypad while a graph is displayed causes the data cursor to jump to the location on the graph that is represented by that key. For example, pressing the 0 key moves the data cursor to the far left end or 0% position on the graph. Pressing the 5 key moves the data cursor to the middle or 50% position of the graph. Pressing the 9 key moves the cursor to the 90% position.
<b>Next Channel Soft Key</b>	
	Graphs data from the next logged channel. For example, if the sampler is logging Level, Flow, and pH and the Level graph is currently displayed, the <b>NEXT CHANNEL</b> key causes the Flow channel to be graphed. Pressing Next Channel again will create a graph for pH channel. Pressing <b>NEXT CHANNEL</b> again returns to the Level graph, selects a time period of interest, and compares different graphs.

## Graphic Display Averaging

The sampler can display a graph that consists of a maximum of 180 individual dots. Since a 24-hour period could contain as many as 1440 data points (assuming a one-minute recording interval, one reading each minute) it would be impossible to plot every data point on the graph.

When more than three hours (more than 180 minutes worth) of data is graphed, the data points must be averaged. When graphing a partial day of three hours or less, all data points are graphed with no averaging.

When viewing a graph with more than 180 data point, zoom in to the area of interest (using the Graph Partial Day option) before all of the individual data points are displayed.

## Sample History

Sample History displays a running history of the sampling program. Displays include sampler number, date and time of each sample, the bottle number it was put in, and the results of the sample cycle. Result messages include:

Message	Results
Success	Sample taken as expected.
No Liquid	No liquid was detected at the liquid sampler.
Key Press	A key was pressed twice during pumping, canceling that sample.

## Options Menu Features

1. From the Main Menu, select **OPTIONS**.

<b>11:00 AM 21 - APR - 01</b>		<b>OPTION MENU</b>
<b>TIME / DATE</b>		<b>VOLUME CALIBRATION</b>
<b>ADVANCED OPTIONS</b>		<b>LEVEL ADJUST</b>
<b>READY TO START</b>		

### Optional Programs

- Time and Date for internal real-time clock
- Calibrate the sample volume
- Advanced Features
- Adjust level readings of optional integral flow meter

## Setting the Time and Date

1. From the Main Menu, select **OPTIONS>TIME/DATE**

<b>11:00 AM 21 - APR - 01</b>		<b>TIME / DATE</b>
<b>ACCEPT</b>		<b>CHANGE AM / PM</b>
	<b>__ : __ AM __ -APR- __</b>	
<b>CLEAR ENTRY</b>	<b>MODE: 12-HR FORMAT</b>	<b>CHANGE MONTH</b>
<b>USE +/- KEY TO CHANGE 12/24 HR FORMAT</b>		

2. Adjust the real time clock and date setting, using **CHANGE AM/PM** and **CHANGE MONTH** keys.

## Volume Calibration

From the Main Menu, select **OPTIONS> VOLUME CALIBRATION**.

The liquid sensor on the sampler offers unparalleled sample accuracy and repeatability. For most site conditions, no volume calibration is necessary, and the volume collected is accurate within 10% of the requested volume. To improve volume accuracy to 5%, or when sample volume accuracy is adversely affected by unusual site conditions (such as the sample source located higher than the sampler pump), or when the liquid sensor is disabled, then volume calibration should be performed.

### Sensor Disabled

When the sensor is disabled, you must calibrate the sample volume(s). If more than one volume is programmed (such as when using storm water or upset sampling), you must calibrate each volume independently (see chart below).

**Sensor Enabled**

When the sensor is enabled, and volume calibration is selected, a single manual calibration is taken. It does not matter if multiple volumes are programmed (such as when using stormwater or upset sampling). When the sensor is enabled, a single “Manual Calibration” choice provides sufficient information to adjust the sensor to all programmed volumes (see [Table 24](#)).

**Table 24 Calibration Volumes**

Liquid Sampler	Available Calibration Volumes
Enabled	Manual Calibration
Disabled	Main Sample Volume
Disabled/Stormwater	Main Sample Volume
	First Flush Volume
Disabled/Upset Sampling	Main Sample Volume
	Upset Sample Volume
Disabled/Storm & Upset	Main Sample Volume
	Upset Sample Volume
	First flush Volume
Disabled/If Timed Rinses Set	Timed Rinse (in addition to the above)

**Calibration Procedure—Sensor Disabled:**

**Note:** Before calibrating, make certain the desired sample volume in the Setup menu is selected.

1. From the Main Menu, press **OPTIONS**.
2. Press **VOLUME CALIBRATION**.
3. Select the desired volume to calibrate if more than one is listed (see [Table 24](#)).
4. Slip the pump tube off the sample fitting (near where it exits the pump housing) and direct the end of the pump tube into a graduated cylinder.
5. Press **START PUMPING**. The pump will purge the line, and start pumping a sample.
6. Press any key when the desired sample volume has been reached in the graduated cylinder. The pump will stop to allow the line to completely drain and then reverse to post-purge the line.
7. If the pumped sample volume is correct, press **DONE**. If not, repeat the calibration cycle by pressing **TRY AGAIN**.
8. When finished, re-install the pump tube onto the sample fitting.

**Note:** To check the sample size after calibration use the Manual Mode function key to take a grab sample. Do not go back into calibration to check the volume since the volume compensation is reset to zero at the start of a calibration.

If one or more Timed Rinses are selected (sensor disabled), then they must be calibrated as well. The Timed Rinse will rinse the intake line up to 3 times prior to taking a sample.

When calibrating a Timed Rinse, the line is purged, then liquid is pumped toward the sensor. When the liquid reaches the predetermined point, press any key to stop the pump. The pump will reverse and purge the line.

### Timed Rinse Calibration Procedure—Sensor Disabled:

1. From the Main Menu, press **OPTIONS**.
2. Press **VOLUME CALIBRATION**.
3. Select Timed Calibrate and press **SELECT**.
4. Press **START PUMPING**. Wait while the pump purges the line, it will then start pulling liquid toward the pump.
5. Press any key when the liquid reaches the desired point. The pump then reverses to post-purge the line. The pump should be stopped when liquid has reached the point past the sensor, but not into the pump body.
6. If the timed rinse stopped where you wanted, press **DONE**. If not, repeat the timed rinse cycle by pressing **TRY AGAIN**.

### Calibration Procedure—Sensor Enabled:

**Note:** Before calibrating, make certain the desired sample volume in the Setup menu is selected.

1. From the Main Menu, press **OPTIONS**.
2. Press **VOLUME CALIBRATION**,
3. Main Calibration is the only choice with the sensor enabled. Press **SELECT**.
4. Slip the pump tube off the sample fitting (near where it exits the pump housing) and direct the end of the pump tube into a graduated cylinder.
5. Press **START PUMPING**. The pump will purge the line, and pump a sample into the graduated cylinder. The pump will then stop to allow the line to completely drain and finally reverse to post-purge the line.

**Note:** To check the sample size after calibration use the Manual Mode function key to take a grab sample. Do not go back into calibration to check the volume since the volume compensation is reset to zero at the start of a calibration.

6. If the sample was taken, then press **DONE**. If not, repeat the cycle by pressing **TRY AGAIN**.
7. After pressing **DONE**, a screen will be displayed asking for the Actual Volume. This is the volume measured in the graduated cylinder. Enter this volume and press **ACCEPT** when done. Note that the requested sample volume is shown on top for reference.
8. When finished, re-install the pump tube onto the sample fitting.



## Data Log

From the Main Menu, select **SETUP > ADVANCED OPTIONS > DATALOG**.

The sampler can record up to 116,000 readings from any or all input channels and store them in solid state, battery-backed memory for later viewing or retrieval.

This option allows the selection of channels to log, how often to log, and how to treat the memory when it becomes full (Slate or Wrap).

The sampler has two data logging modes:

- Power Save Mode
- Continuous Mode

## Logging Intervals

Logging Intervals are designed to optimize the available memory so that readings can be logged for a longer period of time. A logging interval is the time period over which readings are taken and then averaged.

### Power Save Mode

Power Save Mode is automatically initiated upon power-up if a battery is installed on the sampler. When operating in Power Save Mode, the sampler microprocessor spends most of its time asleep conserving battery power. Once per minute, the sampler wakes up, logs the readings from all enabled input channels, performs any other necessary functions and then goes back to sleep.

Selecting a five-minute logging interval means that the readings are still taken every minute but the data is not logged until the five-minute logging interval is complete. At that time the readings are averaged over the previous five minutes and that average is logged

### Continuous Mode

Continuous Mode is automatically initiated upon power up if ac power is supplied. The microprocessor stays awake at all times taking readings every second. At the end of the specified logging interval, the readings are averaged over the previous interval and stored in memory. If a one-minute logging interval is selected, a reading will be taken approximately every second but no data is logged until the logging interval ends. At that time, the readings are averaged over the logging interval and only the average is logged.

If a five-minute logging interval is selected, readings are still taken every second but the data are not logged until the five-minute logging interval ends. At that time, the readings are averaged over the previous five minutes and the average is logged.

### Extended Power Mode

Extended Power Mode provides additional battery life by keeping a sampler powered down during the entire logging interval. For example, if a logging interval of five minutes is selected, the sampler stays asleep until the five minutes has expired. It then wakes up, takes a reading, logs it in memory and goes back to sleep for another five minutes. The sampler does not wake up every minute as it does in normal

## Power Save Mode.

Selecting a five minute logging interval in Extended Power Mode causes a reading to be taken and logged every five minutes. All channels must share the same logging interval.

**Note:** The Review All Items selection from the Setup menu indicates the maximum available logging hours for the channels and recording intervals you selected. The sampler calculates this information when the program is run using the RUN/STOP key.

Longer logging intervals result in a longer total recording time. Lower resolution also occurs since more averaging is done at higher logging intervals. Choose the shortest logging interval possible, while still making data collection convenient. If possible, visit the site once per month to collect data, and choose a logging interval that almost fills memory over the course of one month.

For example, if the sampler is equipped with the standard complement of RAM memory (128K) and only one channel is logged, a two-minute logging interval would take 24 days to completely fill the available memory. If, on the other hand, a one-minute logging interval is selected, the memory would become full after 12 days.

**Table 25 Logging Intervals vs. Total Recording Time for Each Memory Configuration\***

Logging Interval	Total Recording Time (days) before memory is full, with 128K Bytes of RAM (standard) (approx. 18,482 readings)	Total Recording Time (days) before memory is full with 512K Bytes of RAM (optional) (approx. 115,630 readings)
1	12.15	80.55
2	24.30	161.10
3	36.45	241.65
5	60.75	402.75
6	72.90	483.30
10	121.50	805.50
12	145.80	966.60
15	182.25	1208.25
20	243.00	1611.00
30	364.50	2416.50
60	729.00	4833.00

\* Assuming one logged channel.

## Dynamic Memory Allocation

The sampler uses a management scheme called “Dynamic Memory Allocation.” All readings are logged in battery-backed Random Access Memory (RAM). RAM memory is allocated to each channel dynamically during operation. If one channel is logging at five-minute intervals and a second channel logging at one-minute intervals, the sampler automatically configures memory so that both channels fill memory at the same time. Five times as much memory is assigned to the channel that is logging at one-minute intervals than the channel that is logging at five-minute intervals.

Memory can be configured in two ways:

- Slate Modem
- Wrap Mode

**Slate Memory Mode**

Slate mode causes logging to stop when memory becomes full. The sampler continues to operate but no more data is logged. Use this mode to keep data from the beginning of the logging period.

**Wrap Memory Mode**

In Wrap mode, when memory becomes full, the oldest reading is discarded each time a new reading is taken. When memory becomes full, the sampler continues to operate and log data. This mode is best used when interested in the most recent data readings.

**Memory Mode Configuration**

To configure the Memory Mode for either Slate mode or Wrap mode:

1. Select Data Log from the Advanced Options menu.
2. Select Memory Mode using the **UP** and **DOWN** keys, then press **ACCEPT**.
3. Press **CHANGE CHOICE** to choose either Slate or Wrap, then press **ACCEPT** to complete.

**Data Logging Configuration**

To configure the sampler for data logging:

*Note: If logging is enabled on any channel, then that channel will have an arrow in front of it to signify that the channel is logged.*

1. Select Data Log from the Advanced Options menu.
2. Highlight Select Inputs using the **UP** and **DOWN** keys and press **SELECT**.
3. Highlight the channel you wish to log using the **UP** and **DOWN** keys, then press **SELECT**.
4. Press **CHANGE CHOICE** to cycle between Logged and Not Logged, then press **ACCEPT**.
5. Enter a logging interval using the numeric keypad, then press **ACCEPT**. Valid logging intervals are shown on the status bar along the bottom edge of the display for your reference.
6. Select another channel to configure or press **RETURN** to back up one step or press **MAIN MENU** to return to the Main Menu display.

**Diagnostics**

From the Main Menu, select **OPTIONS > ADVANCED OPTIONS > DIAGNOSTICS**.

In addition to the automatic diagnostics that are performed upon power up, the following manual diagnostics are available:

- Distributor Test
- Event List
- Keypad Test
- LCD Test
- Liquid Sensor
- Velocity Analysis

## Distributor Test

The distributor positions the sample tube over the appropriate bottle during multiple bottle sampling. If the distributor arm is obstructed or if a problem exists with the distributor assembly, the arm will not position over the desired bottle correctly.

This test assumes that 24 bottles are installed which is the most difficult to position for the distributor (the most stops and the smallest bottle mouth). Upon selecting the Distributor Test, the arm returns to the bottle #1 position then moves one bottle at a time for all 24 bottle positions. The arm then reverses direction and again stops at all 24 positions on its way back to the bottle #1 position. Make sure no obstructions interfere with the distributor arm rotation.

## Event List

The Event List diagnostic provides a time/date stamped list of significant events occurring in the sampler. You can review these events to find out when an event occurred and what events preceded or followed the event of interest. Events may be viewed in chronological order from the beginning or end of the event list by selecting View From Start or View From End.

The event list cannot be erase, even when the program is started. Up to 200 events are logged before the list wraps around and the oldest entry is discarded as each new entry is posted.

Logged events include:

- Power On/Off
- Level Adjustments
- Program started, stopped, halted, or resumed
- Error Messages
- Alarm Activation/De-activation
- Calibration
- Missed Samples (if liquid sensor is enabled)

## Keypad Test

Keypad Test provides a simple means of verifying the operation of all front panel keys. Select Keypad Test from the diagnostics menu to bring up the following screen:

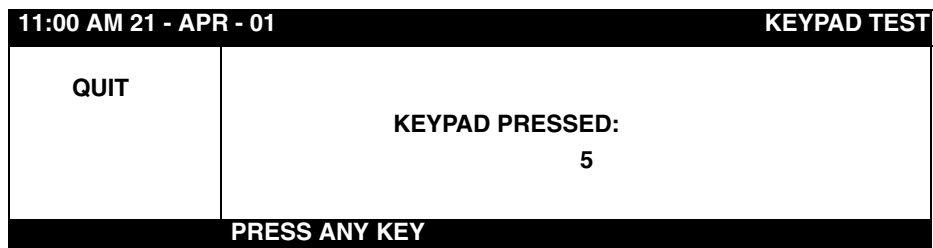

Pressing any key on the front panel (except for the upper left soft key) will cause that key label to appear in the center of the display.

All numeric keypad keys, soft keys, and function keys may be tested in this manner. To end, press **QUIT** (this also verifies the upper left soft key operation).

**LCD Test**

Display Test allows you to verify that all pixels in the Liquid Crystal Display (LCD) are functional. The LCD is made up of 14,400 pixels that are turned on and off as needed to create the display of graphics and text. Each individual pixel is turned on and off by its own transistor, which means that if a transistor failed, the pixel might not turn on, which could cause an unreadable or confusing display.

Selecting LCD Test from the Diagnostics menu will cause the display to become black for 3 seconds. This allows verification that all pixels are functional. A defective pixel will stand out as a white dot in the field of black dots. A message, "The display will remain inverted for 3 seconds" is shown for 2 seconds followed by a 3 second period with all dots turned on.

**Liquid Sensor**

The liquid sensor contains a high frequency sound transmitter and receiver. High frequency sound waves are sent through the silicone pump tubing by vibrating a piezo-electric crystal. They are picked up on the other side of the tubing by a receiving crystal acting much like a microphone. Since sound waves travel much more efficiently through a liquid than they do through air, the receiving crystal gets a much louder signal when water passes through the tubing in the sensor. The signal from the receiving crystal is converted to a voltage which is proportional to the signal strength. This voltage is used by the sampler microprocessor to sense the exact moment water reaches the sensor. the liquid sensor compares the voltage (signal strength) when the tubing is dry (such as when purging the line) to the voltage when the tubing is full of water (such as when pumping a sample). The dry verses wet voltage reading must be at least 0.8 V dc higher than the 0.3 volts, then when the voltage needed to sense liquid would be 1.1 volts or higher.

The Liquid Sensor is designated as #1. The diagnostic screen displays the voltage coming from the sensor electronics. Should a problem arise where the liquid sensor is not reliably sensing the liquid, (inaccurate sample volumes, water getting to the bottle during an intake rinse, purge failure), use of the Liquid Sensor diagnostics values will provide valuable information as to the sensor sensitivity.

**Velocity Analysis**

A velocity probe must be installed in the flow stream and be connected to the meter in order for this diagnostic to work. This diagnostic allows viewing a 'real time' reading directly from the Submerged Area Velocity Probe. It will show the current velocity Signal Strength (percentage of Doppler signal returning to the probe) and a 'real time' velocity measurement of the flow stream. Use this diagnostic to determine if the probe is mounted for optimal velocity measurement. The closer to 100% the Signal Strength is, the more stable the velocity reading will be. If the signal seems low (50% or less), it may be due to improper installation of the probe or a lack of particulate in the flow stream.

11:00 AM 21 - APR - 01		VELOCITY ANALYSIS
<b>RETURN</b>	<b>SIGNAL STRENGTH: 90%</b> <b>VELOCITY: 7.00 fps</b>	

### Load Program

From the Main Menu, select **OPTIONS> ADVANCED OPTIONS> LOAD PROGRAM**.

The sampler stores up to five sets of program instructions. Each program consists of entries made in the Setup Menu and the Advanced Options Menu.

The sampler is shipped with PROGRAM #1 as the loaded program. To see what program is currently loaded, press **REVIEW ALL ITEMS** in the Setup Menu. All program entries made in the Setup Menu and the Advanced Options Menu pertain to the currently loaded program. To change programs, select the program number (1–5), in the Load Program menu, then make the desired changes in both the Setup Menu and the Advanced Options Menu.

To load a new program

1. Highlight Load Program in the Advanced Options Menu. Press **SELECT**.
2. Enter a number from 1 to 5 using the numeric keypad. Press **ACCEPT**.

The Site ID is also displayed on the Load Program Menu for your reference. The Site ID can be modified in the Setup menu.

### Screen Saver Mode

From the Main Menu, select **SETUP > ADVANCED OPTIONS > SCREEN SAVER MODE**.

The power required to properly light the LCD can consume valuable battery life. Screen Saver Mode is a power saving feature of the sampler.

#### Battery Power

When the sampler senses that it is operating on battery power, Screen Saver Mode conserves battery life by automatically turning the LCD display off after 3 minutes of keypad inactivity. Pressing any key will turn the LCD display back on. No configuration is required; the meter automatically senses ac or battery operation on power up.

#### ac Power

When operated under ac power, Screen Saver Mode can be enabled or disabled manually. Enabling the Screen Saver when operating on ac power will prolong the life of the LCD display by minimizing its use.

To change the Screen Saver mode:

1. Highlight **SCREEN SAVER MODE** on the Advanced Options Menu using the **UP** and **DOWN** keys, then press **SELECT**.
2. Press **CHANGE CHOICE** to select a new Screen Saver Mode (Enabled or Disabled). When you have made your selection, press **ACCEPT** to save the changes.

## Flow Totalizer

The Flow Totalizer consists of three numeric counters that keep track of the total flow being measured. Two software totalizers are standard with a third external mechanical totalizer as an option. The two software totalizers consist of a resettable totalizer and a non-resettable totalizer. Both totalizers are set to zero upon program start.

Scaling multipliers are provided to allow tailoring of the totalizer response to meet the requirements of the application. Some applications with high flow rates will require a high scaling factor, while low flow rates will require a low scaling factor.

The scaling factor is displayed whenever a total flow number is displayed. As indicated in the Status Screen below, the total flow is displayed as "TOTAL (x1000): 465 gal." Multiplying the displayed total flow by the scaling factor (1000) gives an actual total flow of 465,000 gallons.

11:00 AM 21 - APR - 01		STATUS SCREEN
LEVEL:	8.688 in.	
FLOW:	71.39 mgd	
TOTAL (X1000):	465 gal	
pH:	7.2 pH	
BATTERY:	16.9 volts	
<b>RUNNING</b>		

- From the Main Menu, select **OPTIONS> ADVANCED OPTIONS > FLOW TOTALIZER** to display the Modify Setup, Reset, and View Total screen.

### Modify Setup

Modify Setup selects a totalizer scaling factor and a flow unit of measure.

- Highlight Modify Setup using the **UP** and **DOWN**. Press **SELECT**.
- Set the Totalizer Scaling factor using the **CHANGE CHOICE** key. All three totalizers are scaled with one of seven scaling factors: X1, X10, X100, X1000, X10,000, X100,000 or X1,000,000. The selected scaling factor always applies to all totalizers. Press **CHANGE CHOICE** to cycle through the available scaling choices.
- Press **ACCEPT** to continue.
- Set the Total Flow Units using the **CHANGE CHOICE** key to cycle through the choices. Total Flow Units are independent of the flow units selected in the Setup Menu. Flow units of measure include:
  - Acre-feet
  - Cubic Feet
  - Liters
  - Cubic Meters
  - Gallons
- Press **ACCEPT** to continue.

### Reset (Totalizer)

The non-resettable totalizer will only be reset if one of the following conditions occur:

- Change in totalizer scaling
- Change in primary device
- Change in totalizer units of measure
- Start of new program

**Note:** *The totalizer cannot be reset manually.*

1. Select **RESET** from the Totalizer menu. A confirmation message will be displayed.
2. Press **YES** to reset the totalizer or press **NO** to not reset the totalizer.

To reset both software totalizers at once, start a program with the **RUN/STOP** key.

**Note:** *If any type of condition occurs, both the resettable and the non-resettable totalizers are reset. The resettable totalizer can be used to total flow over a finite period and can be reset as often as desired without affecting the other totalizers.*

### View Totals

To view the current totals of both the resettable and non-resettable totalizers, press **VIEW TOTALS** from the Totalizer menu. Both totalizer values will appear



## Error Messages

Error Message	Reason
*****Warning!***** Logged data will be lost if you choose to continue? Yes/No.	Making a program change when a program is halted.
<ul style="list-style-type: none"> <li>A minimum of 4 points are required.</li> <li>The entered level value must be greater than the previous value.</li> <li>No values have been entered in the selectable table.</li> </ul>	When entering level-flow or area-level tables, or when attempting to use the tables, a minimum of four points must be entered to create a valid table, and level values must increase value as they are entered.
Bottle number must be: 1–xx (where xx = #bottles in the tray).	When selecting a bottle to move to after selecting distributor movement from the manual menu screen.
Bottle quantity must be: 1, 2, 4, 8, 12, 24.	An invalid bottle quantity was entered.
Calibration requires a minimum submersion of six inches.	Level sensor calibration of the bubbler or submerged sensor.
Day must be: 01–xx (where xx is the last day in month).	Invalid number when setting a date.
Distributor movement halted due to key press.	A key was pressed during the distributor test (diagnostics) or distributor movement from the manual menu screen.
Error: Distributor arm is not functioning properly!	The distributor test failed due to an arm obstruction, cable not installed properly, or defect in the distributor assembly.
Function disabled while a program is running. Use <b>RUN/STOP</b> key.	Attempted to use manual menu functions or the distributor test while the program is running.
Hours must be: 00–23.	Invalid number entered when setting a time, 24-hour format.
Hours must be: 01–12.	Invalid number entered when setting a time, 12-hour format.
Incorrect password! Access denied.	Incorrect password was entered (password is <b>9000</b> ).
Interval must be: 000:01–xxx:xx (where xxx:xx is max. interval).	An invalid duration (hrs:min) was entered.
Invalid floating point format, only one decimal point allowed.	A number was entered with two or more decimal points.
Logging intervals must be: 1,2,3,5,6,10,12,15,20,30,60.	An invalid logging interval was entered.
Minutes must be: 00–59.	Invalid number entered when setting a time.
No changes allowed while a pgm is running. Use run/stop key.	An inaccessible selection was made on a menu screen. Stop the program before proceeding.
No retries are possible when the liquid sensor is disabled.	Occurs if Sample Retries is selected from the Modify Selected Items scrolling list, and liquid sensor are disabled. Enable liquid sensor to use retries.
No year entered.	Invalid number entered when setting a date.
pH calibration failed—gain and/or offset out of range. Try again.	The pH calibration calculations yielded an invalid number. Try fresh buffers or a new probe.
Pumping took too long, please try again.	Occurs when the maximum time for timed calibration of a sample volume (or rinse) is exceeded (the maximum is 65000 tens-of-milliseconds, which is roughly equal to 10.5 minutes).
<ul style="list-style-type: none"> <li>Sampling halted because of key press.</li> <li>Sampling halted because the bottle is full.</li> <li>Sampling halted due to fluid presence after pre-purge.</li> <li>Sampling halted during rinse—no liquid detected.</li> <li>Sampling halted due to fluid presence after rinse purge.</li> <li>Sampling halted—no liquid detected during sample phase.</li> </ul>	May occur at the end of a sample attempt. Messages are self explanatory. Investigate the tubing setup from strainer to liquid sensor. Strainer may be plugged or out of water. Tubing may not be installed properly in liquid sensor.
Sensor output voltage too low—cannot calibrate.	The D.O. calibration yielded an invalid result. Try another probe.
Setpoint Sampling and Storm Water cannot both be enabled.	Enabled Setpoint Sampling with Storm Water enabled, or enabled Storm Water with Setpoint Sampling enabled.

## Appendix C

Stormwater mode is not allowed when the sampler is configured with one bottle.	Tried to enable Storm Water with a single bottle.
The program cannot start: timed rinse required.	Occurs if the liquid sensor is disabled and timed calibration has not been performed for the rinse cycle.
The program cannot start: the primary device is not properly set up.	If the operator goes partially through the flow meter setup screens but stops before entering all necessary parameters.
The program cannot start: volume calibration required.	If the liquid sensor is disabled and timed calibration has not been performed for the main sample, the first flush or the upset sample volume.
The program setup needs flow to be logged at an interval $<$ or $=$ the flow time limit.	If an alarm, setpoint or stormwater uses flow rate-of-change as a trip point.
The program setup needs rain to be logged at an interval $<$ or $=$ the rainfall time limit.	If an alarm, setpoint or stormwater uses rainfall as a trip point.
The signal did not stabilize in time—calibration failed.	When calibrating pH, process temperature, ORP, D.O., D.O. temperature, conductivity, or conductivity temperature, the signal from the probe did not respond within the calibration time limits. Replace buffer solutions (if applicable) or try another probe.
<ul style="list-style-type: none"> <li>The time entered is before the first logged value. Data will be display from beginning.</li> <li>The time entered is after the last logged value. Data will be displayed from the end.</li> </ul>	When selecting the time/date for graphing and the selected beginning or ending time falls outside the range of data.
The value must be: xxx—yyy (xxx is minimum, yyy is maximum).	The value entered was out of the legal range, when changing any numeric parameter. The appropriate range is always displayed on the bottom line on the entry screen.
<ul style="list-style-type: none"> <li>This program stop is prior to the last program start.</li> <li>This program start is prior to the last program stop.</li> </ul>	When entering start/stop times. Start/stop times must be entered in chronological order.
Timed bottle sets are not allowed unless distribution is bottles-per-sample mode.	Tried to enable Timed Bottle Sets when bottles per sample have not been specified (the bottles-per-sample is used as the bottle set quantity).
Timed bottle sets are not allowed when the sampler is configured with one bottle.	Tried to enable Timed Bottle Sets with a single bottle.
Times cannot be more than 24 hours apart.	When selecting a start and stop time for a graph display the limit (due to screen resolution) is 24 hours.
Too few bottles—review timed bottle sets, upset sampling, & stormwater. Minimum needed:	Occurs if there are not enough bottles to perform all the various functions. Either install more bottles or decrease number of programmed functions.
Too many alarms and setpoints have been requested.	Occurs if more than 20 alarm and setpoint conditions are set. Storm Water start conditions use one or two setpoints.
Too many samples-per-bottle for the bottle volume: The sample volume is too large for the bottle volume:	Occurs when the sample volume is checked, if the requested sample volume is too big to fit in the bottle.
Upset sampling is not allowed when the sampler is configured with one bottle.	Tried to enable Upset Sampling with a single bottle.

## Trouble Alarm Conditions, Causes, and Solutions

Trouble Condition	Cause	Solution
Low Main Battery	Power supply voltage is less than 11 V dc.	Change batteries.
Memory Battery	Internal memory battery voltage is too low.	Change memory batteries.
Low Slate Memory	Free slate memory is less than 20%. RAM memory is almost full and will stop recording soon.	Download data from unit, halt and restart the program or download data, halt, and change data to wrap mode.
Slate Memory Full	No more slate memory. Unit is in slate memory mode and cannot log any more data.	Download data and restart the program or download data then change the memory mode.
Modem Failure	Unable to initialize modem PCB.	If the modem is enabled, the problem may be found on the modem board and the board may need to be replaced.
Missed Sample	Sample cycle did not result in getting a sample.	—
Purge Failure	Sensor(s) still detecting liquid after a line purge.	—
Jammed Distributor	Distributor arm has jammed on an obstruction.	Remove obstruction
Unable to Cool	Refrigeration system is unable to reduce temperature in refrigeration compartment to user defined setpoint.	—
Unable to Heat	Heater is unable to increase temperature in refrigeration compartment to user defined setpoint.	—
U-Sonic Echo Loss	The echo has been temporarily deflected by a change in site conditions such as floating debris or foam in the channel, wind, etc.	Check for excessive foam. Remove any debris or build-up.
Xducer Ringing	Transducer is operating within the deadband	—
U-Sonic Failure	Transducer not plugged in. Cable damaged. Transducer thermal sensor damaged.	Check that the transducer is plugged in and that there is no damage to the sensor.
RS485 Timed Out	Communication error between CPU and remote ultrasonic module.	—
	CPU is not communicating with the Velocity board.	Wait a few minutes to see if it goes away, if it continues it is an indication that there is a problem with the CPU board.
	Not receiving a good velocity reading.	If the logging interval is 1 or 2 minutes and conditions are poor with the problem continuing indefinitely, try increasing the logging interval to allow more time to capture the signal.

Downlook Ultrasonic Sensor Troubleshooting

Problems	Causes	Solutions
RS485 Time Out—Did not get a reading with the specified time allotted.	CPU is having trouble communicating with the Ultrasonic board.	Wait a few minutes and see if the condition goes away. If it continues there may be a problem in the Ultrasonic, Velocity, or CPU board.
	Difficulty receiving a velocity reading.	Indicates an internal problem.
Loss of Ultrasonic as Level Measuring Device.	Blown fuse on CPU board.	Replace fuse. The fuse is located in position F1 under the gray ribbon cable that connects at position J1.
	Problem with the ultrasonic board.	Replace if necessary.
U-Sonic Echo Loss—Flow Meter Not Receiving a Return Echo from the Ultrasonic Transducer.	Excessive foam on the water surface causes sound waves to be absorbed rather than reflected.	Check for excessive foam.
	Sensor is knicked or cut or improperly installed.	Check for knicks, cuts, and the sensor installation.
	Sensor must be level for proper return of signals.	Make sure the ultrasonic transducer is level.
	Convection currents are present which varies the speed of sound.	Try shielding the transducer from convection currents. Echo loss should not exceed more than two hours.
	Temperature calibration set up incorrectly. Extreme high or low temperature indicates a bad temperature transducer in the temperature sensor.	Go through the temperature calibration procedure and determine what the temperature the unit is sensing. Replace transducer if necessary.
U-Sonic Failure—No Signal from the Ultrasonic Transducer.	Transducer is not connected.	Check the ultrasonic sensor connection on the flow meter.
	Cut or broken cable.	Check for any nick or cuts in the cable.
	Unusual temperature or inability to read new calibrated level.	Re-calibrate the unit.
XDucer Ringing—False Return Echo mask Real Echoes.	Liquid is too close to the transducer.	Try moving the transducer farther from the liquid.
	Obstructions under the transducer.	Check for obstructions on the front and sides of the transducer.
	Coating on the face of the transducer.	Clean the transducer face. If this is a constant problem, try coating the face of the transducer with a very thin film of silicone grease to keep the debris from collecting.
	The transducer resonates against steel mounting rails.	Use the proper rubber isolation washers.
No Change in Level Readings or Inaccurate Level Readings.	—	Check the logged data to see when this started to occur. Go to the event log to see if anything happened during the same time.
	Calibration	Re-calibrate the unit.
	Bad transducer.	Try a different transducer.

## pH Troubleshooting

Symptom	Possible Cause	Solution
Meter continuously reads pH 14 or drifts above 14.	Open circuit in either glass or reference electrode.	<ul style="list-style-type: none"> <li>Inspect the cable and connector of the faulty electrode for evidence of a crushed or broken cable jacket or brittleness of the cable due to exposure to heat. Discard the electrode if damage is present.</li> <li>Manipulate meter/electrode connections to check for intermittent continuity. Replace if faulty.</li> <li>Inspect the bulb, making sure it is filled with solution. If not, shake down (like a clinical thermometer) to displace air in the pH bulb. Retest.</li> <li>Inspect the bulb for signs of coating.</li> </ul>
Temperature is constant or incorrect.	Interface is wired wrong.	Check interface wiring.
	Thermistor is open.	Check interface wiring. Check for open at electrode RTD wire. Disconnect to make measurement. (Should read approximately 100–110 ohms.)
Electrode won't calibrate.	Gain or offset error.	<ul style="list-style-type: none"> <li>Ensure that solutions are fresh and labeled properly.</li> <li>Confirm that electrode and buffer temperatures have stabilized.</li> <li>Confirm that the wetting cap is removed.</li> <li>Check bulb for cracks or other damage.</li> <li>Confirm that interface wires are connected properly.</li> <li>Check interface connections for corrosion.</li> </ul>
Slow response and/or erratic readings.	Very high impedance in either glass or reference electrode.	<ul style="list-style-type: none"> <li>Inspect the pH bulb for coating or clogging. If present, clean thoroughly.</li> <li>Keep the electrode wet at all times. If it dries out, the impedance will increase dramatically. To restore performance, soak in 0.1 N HCl (Cat. No. 1481253) for 30 minutes and rinse well with distilled water.</li> <li>Chemical degradation of pH glass can occur rapidly in a high temperature or high pH environment, yielding sluggish response. Low temperature environments can double the impedance for every 8 °C drop below 25°C.</li> <li>A high impedance electrode is extremely sensitive to electrical noise, e.g., oscillating electrical fields generated by motors, generators or discharges from electrical thermostats. A free-hanging cable swinging due to air currents will also generate erratic signals.</li> <li>Manipulate electrode cable and connections to check for intermittent continuity. Replace as necessary.</li> </ul>
	Ground loop problem.	<ul style="list-style-type: none"> <li>Check to see if the ground wire is connected properly at the pre-amp junction box.</li> <li>Check for continuity between the stainless steel lug on the electrode and the ground wire at the interface.</li> </ul>
	Temperature is incorrect.	See "Temperature" symptom in this table.
No response to pH change.	Cracked glass bulb.	If the electrode gives readings between 5.8 and 6.2 pH in all solutions, inspect the glass bulb. If damaged, discard.
	Short Circuit.	If a constant reading of 7.0 pH or 0.0 mV is obtained, inspect the cable. If no visible damage exists, remove the connector and test for a short circuit. Replace if faulty.
	High impedance bridge.	Inspect the connector for moisture or corrosion. If wet, rinse well with distilled water and dry thoroughly. Determine the cause of wetness and correct it.

**Sigma 900 MAX Refrigerated Sampler Troubleshooting Issues**

<b>Problem</b>	<b>Cause</b>	<b>Solution</b>
Instrument Will Not Power Up With ac Power.	Blown Fuse.	Check the 5-amp fuse on the back of the controller.
	Circuit breaker issue.	Check the circuit breaker for the main power.
	Breaker is good, but still no power.	Check to see if the outlet is receiving power.
	Breaker and outlet are good, still no power.	Try using a battery or another power supply
Sampler Will Not Create Sufficient Lift.	If any holes on the anchor strainer are not submerged the sampler will not create a lift.	Make sure the anchor strainer is completely submerged.
	Intake tubing is nicked or has a small hole.	Replace with new tubing.
	Worn roller assembly and/or pump tubing.	Replace assembly and/or tubing.
Inaccurate Sample Volumes	The volume was calibrated incorrectly the first time.	Make sure the proper calibration method is used for the site conditions (Auto or Timed calibrate).
	Incorrect intake tube length is programmed in the sampler.	Re-enter the tube length.
	Intake tubing is not completely purging.	Place the tubing at a downward slope from the sampler to the liquid source.
	Anchor stainer is intermittently submerged.	Install the shallow depth anchor strainer, (Cat. No. 2071 or 4652).
	Worn roller assembly and/or pump tubing.	Replace assembly and/or pump tubing.
	When using "Timed Calibrate" (liquid sensor disabled) variable lifts will cause variable sample volumes.	Enable sensor and calibrate volume if site conditions allow.
	Liquid sensor is not functioning properly.	Check the liquid diagnostics screen for valuable information about sensor sensitivity.
	RPM's of the motor vary.	Replace motor if necessary.
Submerged Pressure Sensor level readings are inaccurate or no change in level readings.	Improper calibration.	Make sure the unit has been calibrated.
	Desiccant is pink.	Replace the desiccant.
	The sensor was not acclimated to the air temperature before calibrated.	Re-calibrate the sensor making sure the sensor is at ambient temperature.
	Water or debris in the atmospheric reference tube.	Clean the area and re-calibrate. To reduce debris on the cable and mounting band, route the cable along the edge of the band and wrap the cable and mounting band with plastic tape. The cable should exit at or near the top of the pipe to keep it out of the flow stream.
	Level is trending downward because debris at the diaphragm.	Remove the plate and carefully clean the transducer. Re-calibrate the sensor.

The sampler is equipped to receive either a momentary dry contact closure or a +5 to +12 V dc pulse from a flow meter, where each pulse represents a known flow increment.

For example, if the flow meter is set to send a flow pulse for every 1000 gallons of measured flow and the sampler can count 1 to 9,999 flow pulses between sample intervals, you can program the sampler to receive 10 pulses between samples to take one sample for every 10,000 gallons of liquid flow.

To determine the number of flow pulses between sample intervals, you must determine the total number of samples (represented by  $n$  in the following examples) to be collected, and the period of time over which they are to be collected. You must also know the total flow,  $Q$ , during the sampling program. The following two-step method should be useful for determining the value for  $INTV = \text{---} \text{CNTS}$  during setup.

1. Determine  $f$ , where  $f$  represents the flow increment between samples and  $n$  represents the total number of samples to be collected.

$$f = \frac{Q}{n}$$

2. Multiply the flow increment between samples,  $f$ , by the pulse frequency output of the flow meter (i.e. 1 pulse per 100 gallons, 1 pulse per 1000 gallons, etc.). If the pulse frequency output of the flow meter is not known, consult the flow meter manufacturer.

**Note:** The final result is not necessarily a whole number. You must round off the result to the nearest whole number.

#### Flow-Proportional Sampling Intervals - Using External Pulses

Hach samplers are equipped to receive either a momentary dry contact closure or +5 to +12 V dc pulse from a flow meter, where each pulse represents a known flow increment.

#### Example 1

You want to collect 35 samples over a 24-hour period. The total expected flow over this period is 235,000 gallons. The flow meter pulse frequency is one pulse for every 100 gallons.

1. Determine the flow increment between samples:

$$f = \frac{Q}{n} = \frac{235,000 \text{ gallons}}{35 \text{ samples}} = 6,714 \text{ gallons/sample}$$

2. Multiply the flow increment,  $f$ , by the pulse frequency output of the flow meter.

$$6,714 \text{ gallons/sample} \times \frac{1 \text{ pulse}}{100 \text{ gallons}} = 67.14 \text{ pulse/sample}$$

Therefore, the value for  $INTV = \text{---} \text{CNTS}$  is 67.  
(67.14 is rounded off to 67.)

#### Example 2

You want to collect 24 samples over an 8-hour period. The total expected flow over this 8-hour period is 85,000 gallons. The flow meter pulse frequency output is one pulse for every 50 gallons.

1. Determine the flow increment between samples:

$$f = \frac{Q}{n} = \frac{85,000 \text{ gallons}}{24 \text{ samples}} = 3,542 \text{ gallons/sample}$$

2. Multiply the flow increment,  $f$ , by the pulse frequency output of the flow meter.

$$3,542 \text{ gallons/sample} \times \frac{1 \text{ pulse}}{50 \text{ gallons}} = 70.84 \text{ pulse/sample}$$

Therefore, the value for **INTV** = \_ \_ \_ \_ **CNTS** is 71.

### Example 3

You want to collect 48 samples over a 16-hour period. The total expected flow over this period is 1,750,000 gallons. The flow meter pulse frequency output is one pulse for every 1,000 gallons.

1. Determine the flow increment between samples:

$$f = \frac{Q}{n} = \frac{1,750,000 \text{ gallons}}{48 \text{ samples}} = 36,458 \text{ gallons/sample}$$

2. Multiply the flow increment,  $f$ , by the pulse frequency output of the flow meter.

$$36,458 \text{ gallons/sample} \times \frac{1 \text{ pulse}}{1,000 \text{ gallons}} = 36.458 \text{ pulses/sample}$$

Therefore, the value for **INTV** = \_ \_ \_ \_ **CNTS** is 36.

### Flow Proportional Sampling, External—Using 4–20 mA Signal Converted to Pulses, Flow Signal Interface

The Flow Signal Interface (Cat. No. 2021) is an optional 4–20 mA interface that converts 4–20 mA current signals (from a flow meter) to 12 V dc pulses.

At 20 mA, the interface transmits 10 12-volt pulses per minute. As the current signal decreases, the 12 V pulses decrease proportionally. Typically, users collect a certain number of samples over a given period of time when sampling in proportion to the flow rate.

To calculate the number of 12 V dc output pulses between samples, determine the total number of samples (represented by  $n$  in the following examples) that you want to collect, and the period of time over which you want to collect them. Use the three-step method presented below to determine the “Total Count” value that you will enter while programming the Setup section of the sampler.

1. Calculate  $Q$ , where  $Q$  is the average flow rate (during the sampling program) divided by the maximum flow rate. (The maximum flow rate corresponds to the 20 mA output of the flow meter.)
2. Calculate  $t$ , where  $t$  is defined as  $a/n$ ;  $n$  is the total number of samples collected over a given period of time; and  $a$  represents time in minutes, over which  $n$  samples are collected.
3. Multiply  $Q \times t \times 10$ . Enter the result in the programming step:  
**INTV** = \_ \_ \_ \_ **CNTS**.

**Note:** The product of  $Q \times t \times 10$  is not necessarily a whole number. You must round off the result to the nearest whole number.



Use the following examples to help you determine the value that you need to enter when programming for sampling based on counts.

**Example 1**

You want to collect 24 samples over a 24-hour period on a 4–20 mA flow proportional basis.

Average Flow Rate = 3.5 mgd (average flow rate over the 24-hour period)

Maximum Flow Rate = 10 mgd

a = 1440 minutes

1. Calculate  $Q$ .

$$Q = \frac{\text{Average Flow Rate}}{\text{Maximum Flow Rate}} = \frac{3.5 \text{ mgd}}{10 \text{ mgd}} = 0.35 \text{ mgd}$$

2. Calculate  $t$ .

$$t = \frac{a}{n} = \frac{1440 \text{ min}}{24 \text{ samples}} = 60 \text{ min/sample}$$

3. Multiply  $Q \times t \times 10$ .

$$0.35 \text{ mgd} \times 60 \text{ min/sample} \times 10 = 210$$

Therefore, the value entered for **INTV** = \_\_\_\_\_ **CNTS** is 210.

**Example 2**

You want to collect 48 samples over a 24-hour period on a 4–20 mA flow proportional basis.

Average Flow Rate = 1.75 mgd (average flow rate over the 24-hour period)

Maximum Flow Rate = 3 mgd

a = 1440 minutes

1. Calculate  $Q$ .

$$Q = \frac{\text{Average Flow Rate}}{\text{Maximum Flow Rate}} = \frac{1.75 \text{ mgd}}{3 \text{ mgd}} = 0.583 \text{ mgd}$$

2. Calculate  $t$ .

$$t = \frac{a}{n} = \frac{1440 \text{ min}}{48 \text{ samples}} = 30 \text{ min/sample}$$

3. Multiply  $Q \times t \times 10$ .

$$0.583 \text{ mgd} \times 30 \text{ min/sample} \times 10 = 174.9$$

Therefore, the value entered for **INTV** = \_\_\_\_\_ **CNTS** is 175.

**Example 3**

You want to collect 96 samples over a 24-hour period on a 4–20 mA flow proportional basis.

Average Flow Rate = 0.52 mgd (average flow rate over the 24-hour period)

Maximum Flow Rate = 2 mgd

a = 1440 minutes

1. Calculate  $Q$ .

$$Q = \frac{\text{Average Flow Rate}}{\text{Maximum Flow Rate}} = \frac{0.52 \text{ mgd}}{2.0 \text{ mgd}} = 0.26 \text{ mgd}$$

2. Calculate  $t$ .

$$t = \frac{a}{n} = \frac{1440 \text{ min}}{96 \text{ samples}} = 15 \text{ min/sample}$$

3. Multiply  $Q \times t \times 10$ .

$$0.26 \text{ mgd} \times 15 \text{ min/sample} \times 10 = 39$$

Therefore, the value entered for INTV = \_\_\_\_\_ CNTS is 39.

### Example 4

You want to collect 32 samples over an 8-hour period.

Average Flow Rate = 70 gpm (average flow rate over the 8-hour period)

Maximum Flow Rate = 210 gpm

$a = 480$  minutes

1. Calculate  $Q$ .

$$Q = \frac{\text{Average Flow Rate}}{\text{Maximum Flow Rate}} = \frac{70 \text{ gpm}}{210 \text{ gpm}} = 0.33 \text{ gpm}$$

2. Calculate  $t$ .

$$t = \frac{a}{n} = \frac{480 \text{ min}}{32 \text{ samples}} = 15 \text{ min/sample}$$

3. Multiply  $Q \times t \times 10$ .

$$0.33 \text{ mgd} \times 15 \text{ min/sample} \times 10 = 49.5$$

Therefore, the value entered for INTV = \_\_\_\_\_ CNTS is 50.

### Example 5

It is desired to collect 30 samples over a 2-day period.

Average Flow Rate = 0.25 cfs (average flow rate over the 48-hour period)

Maximum Flow Rate = 1 cfs

$a = 2,880$  minutes

1. Calculate  $Q$ .

$$Q = \frac{\text{Average Flow Rate}}{\text{Maximum Flow Rate}} = \frac{0.25 \text{ cfs}}{1 \text{ cfs}} = 0.25 \text{ cfs}$$

2. Calculate  $t$ .

$$t = \frac{a}{n} = \frac{2,880 \text{ min}}{30 \text{ samples}} = 96 \text{ min/sample}$$

3. Multiply  $Q \times t \times 10$ .

$$0.25 \text{ cfs} \times 96 \text{ min/sample} \times 10 = 240$$

Therefore, the value entered for INTV = \_\_\_\_\_ CNTS is 240.

You will notice from the previous five examples that the average and maximum flow rate can be expressed in any units, i.e. mgd, gpm, cfs, etc. However, express the average and maximum flow rate in the **same units** for any given situation.

## Sigma 900 MAX Refrigerated Sampler Assembly Drawing (1 of 3)

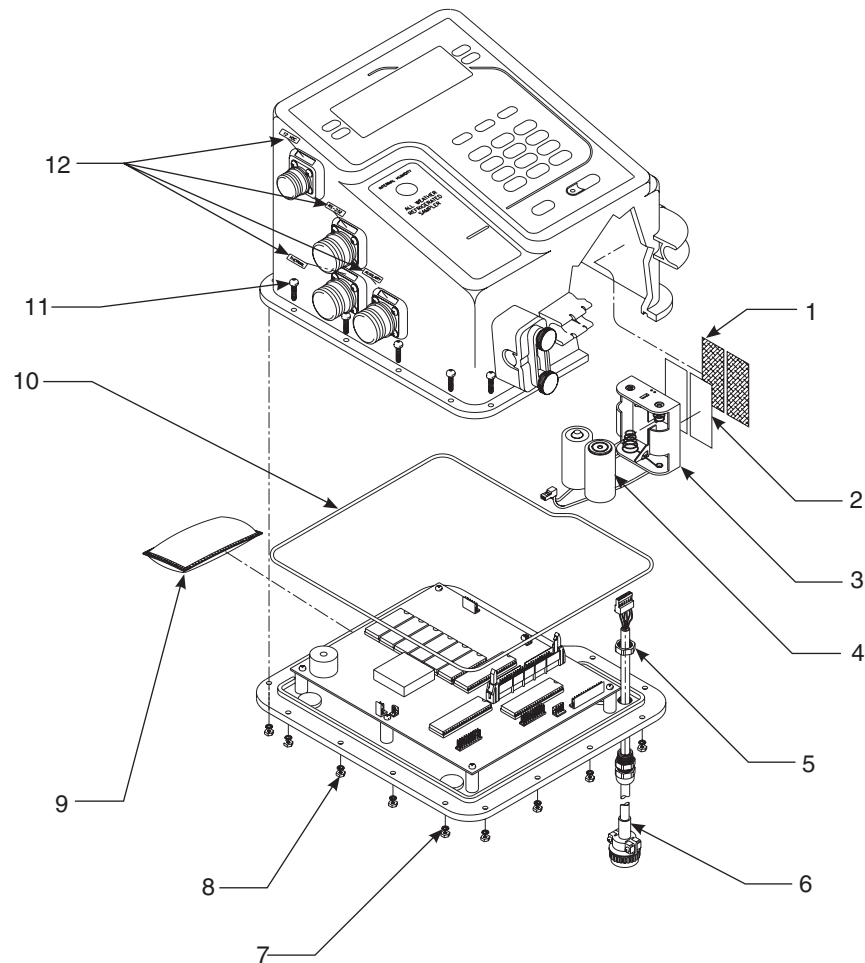

Item	Description	Quantity	Catalog Number
1	Hook and Loop Fastener	2	8791
2	Hook Fastener	1	8792
3	Battery Pack	1	8765
4	C-cell Battery	2	2709
5	Power Supply Cable Assembly	1	8783
6	Distributor Cable Assembly	1	8623
7	Nut	17	SE 301
8	Lock Washer	17	SE 306
9	Desiccant Bag	1	8849
10	O-ring (8606) Lubricant	1	SE 1048
11	Screw	17	SE 343
12	Overlay	1	8807

Sigma 900 MAX Refrigerated Sampler Assembly Drawing (2 of 3)

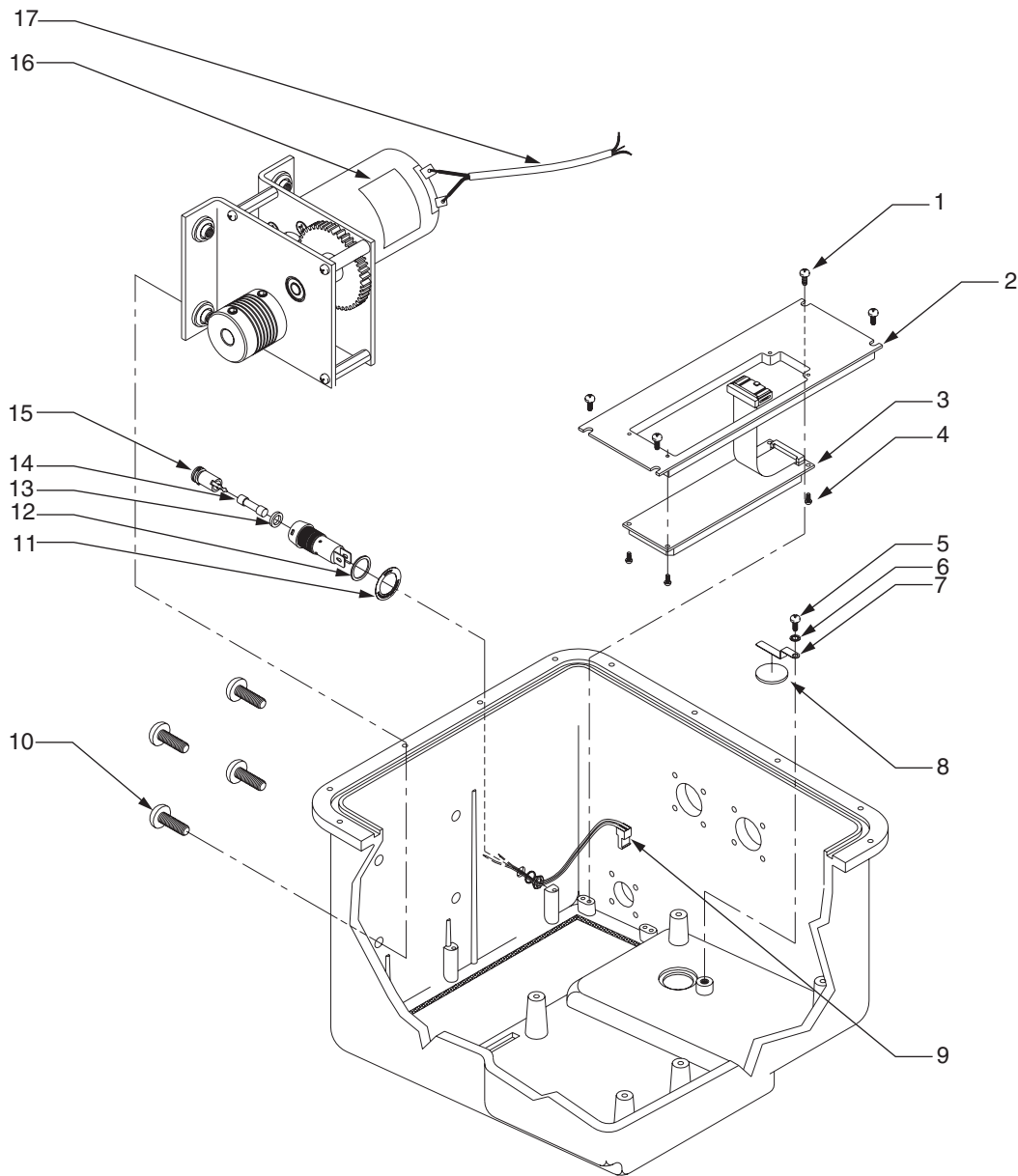

Item	Description	QTY	Cat. No.	Item	Description	QTY	Cat. No.
1	Screw	4	SE 244	10	Screw	4	SE 738
2	Bracket	1	8898	11	Overlay, Fuse Holder	1	1436
3	Display Assembly	1	8911	12	O-ring, 1 x 10 mm	1	3319
4	Screw	4	SE 105	13	O-ring	1	3321
5	Screw	1	SE 214	14	Fuse, 5-A, 250-V, Slow-blow	1	8753
6	Washer	1	SE 208	15	Fuse Holder, 5 x 20 mm	1	3320
7	Bracket, Desiccant Card	1	2594	16	Gear Box Assembly	1	8910
8	Humidity Indicator Card	1	2660	17	Cable Assembly, Motor	1	8859
9	Cable Assembly, Fuse Holder	1	3146				

## Sigma 900 MAX Refrigerated Sampler Assembly Drawing (3 of 3)

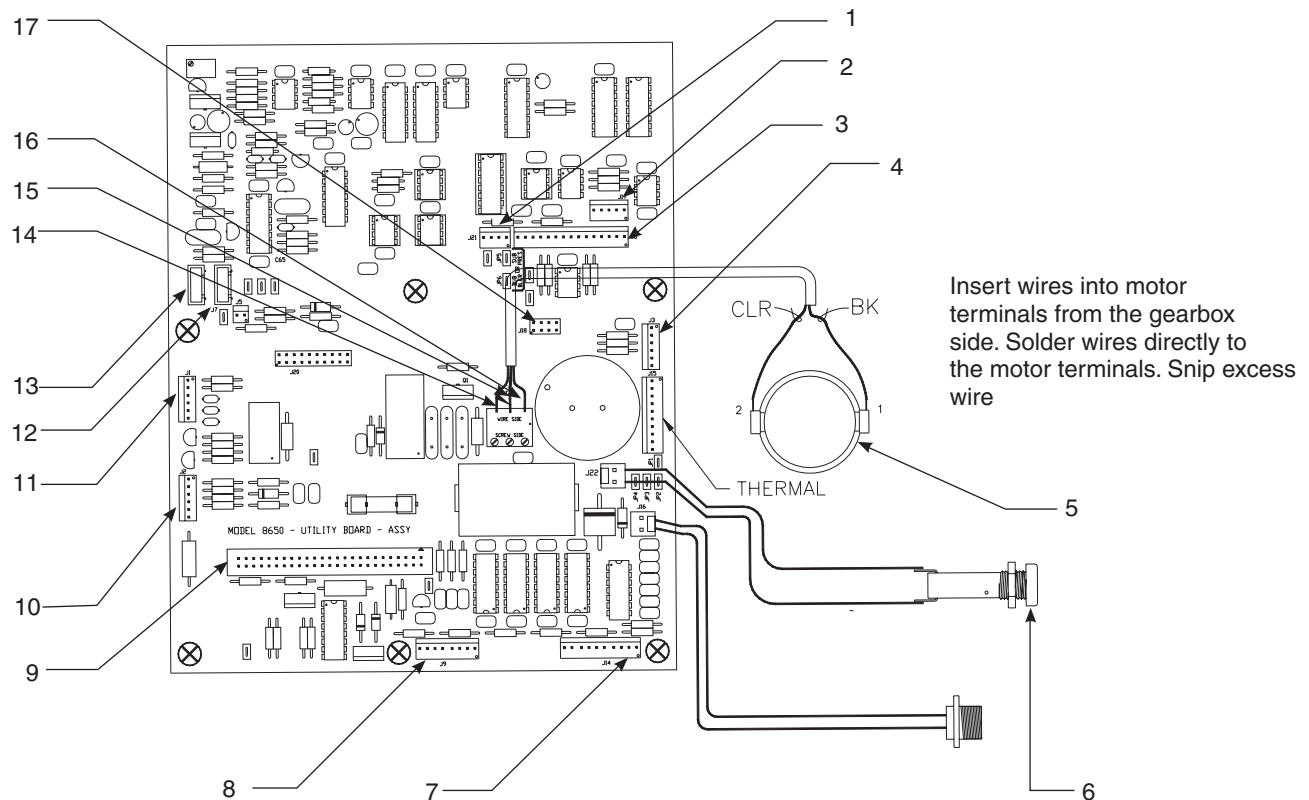

Item	Description
1	Sub Probe
2	Relay Option
3	Bubbler
4	pH/ORP
5	Gearbox Assembly (Cat. No. 8910)
6	Fuse Holder, 5 x 20 mm (Cat. No. 3320)
7	DO and Conductivity
8	Three Channel Data Log
9	CPU
10	AUX
11	Distributor
12	Sensor 2
13	Sensor 1
14	Black TB1-3
15	Shield TB1-2
16	Clear TB1-1
17	4-20 mA

Sigma 900 MAX Refrigerated Composite Sampler Assembly

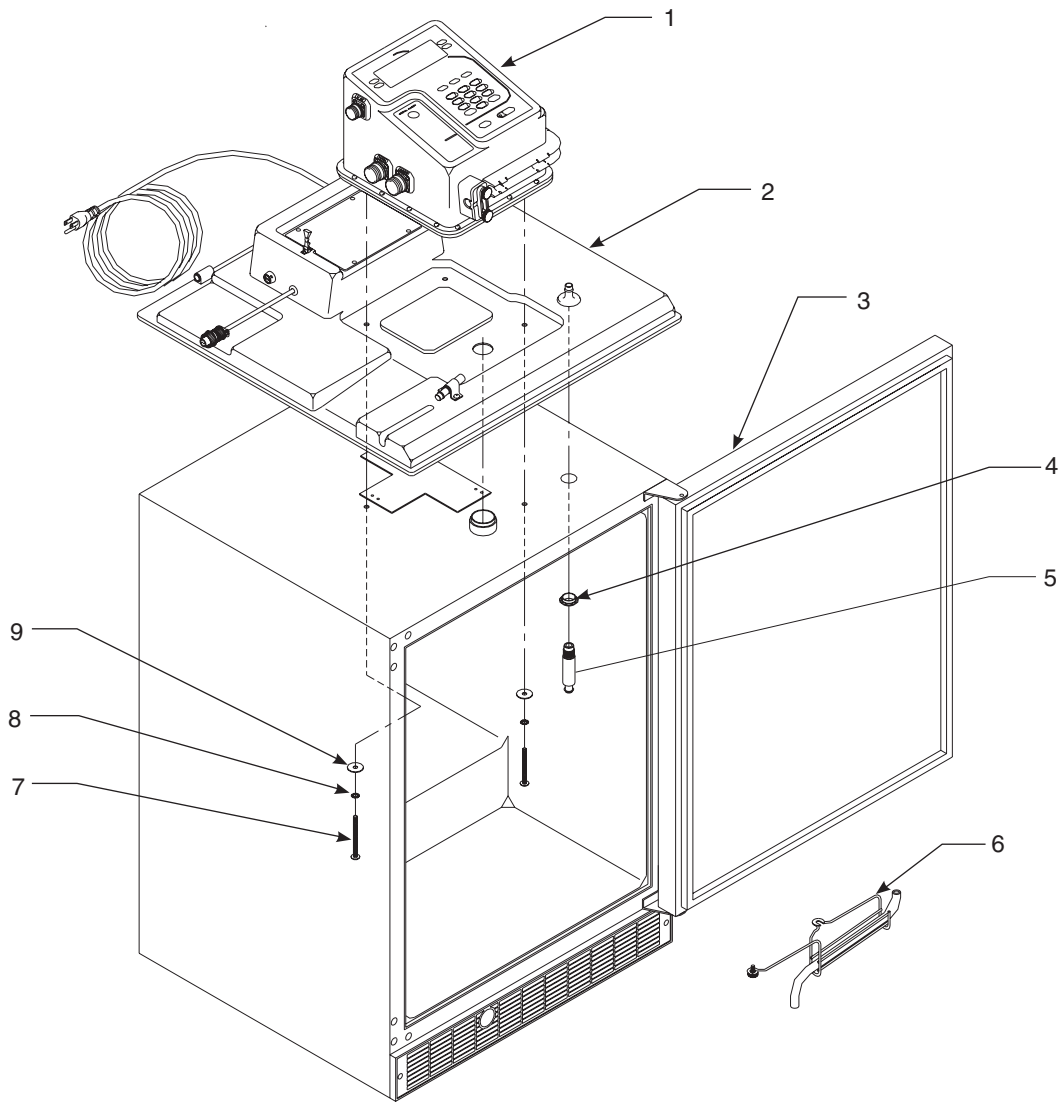

Item	Description	Catalog Number
1	900 Refrigerated Sampler	8971
2	120-V Transition Assembly	8924
3	Composite Refrigerator Sampler	8955
4	Grommet	2050
5	Sample Extension Fitting	8966
6	Composite Tube Support	8938
7	Screw	SE 724
8	Lock Washer	SE 708
9	Washer	SE 728

## Sigma 900 Composite Refrigerator Assembly

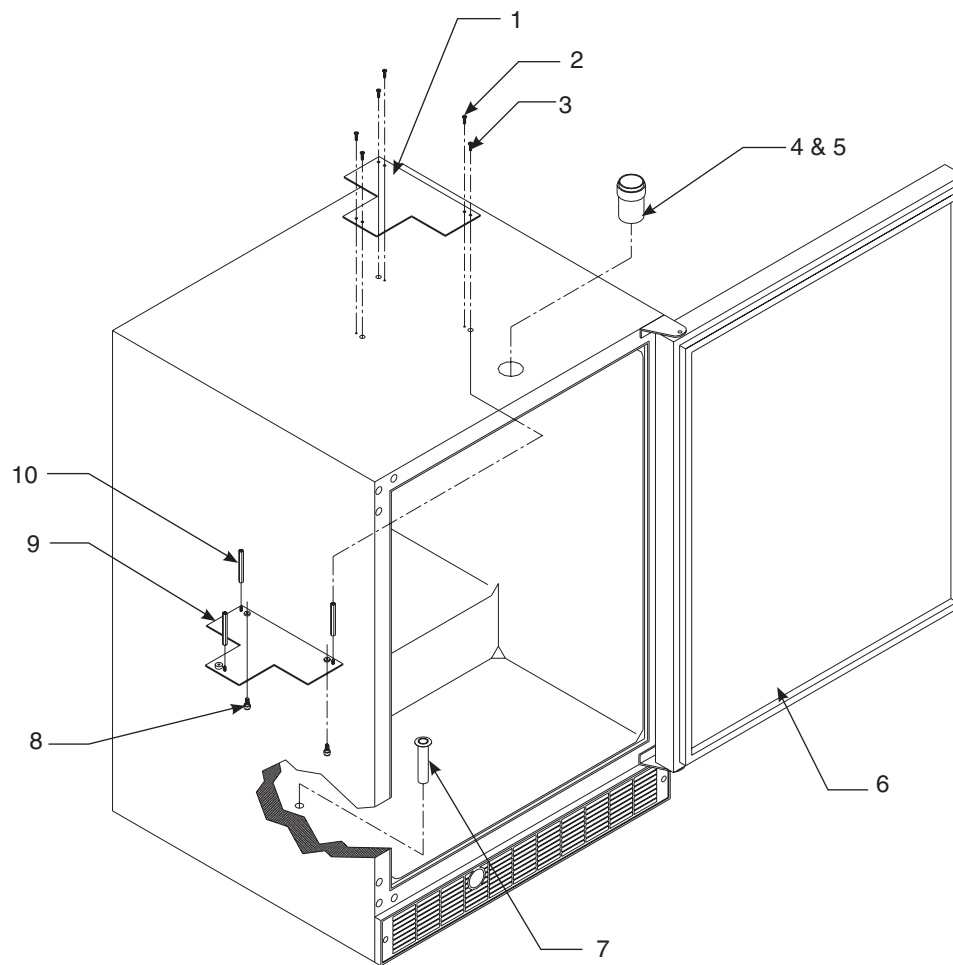

Item	Description	Quantity	Catalog Number
1	Plate	1	8979
2	Screw	3	SE 313
3	Screw	3	SE 312
4	Cable Feed-thru Fitting	1	8967
5	Sealant	1	SE 979
6	120-V Refrigerator	1	7686
7	Molded Fitting (Adhesive SE 1054)	1	8936
8	Screw	2	1519
9	Distributor Mounting Plate	1	8978
10	Standoff	3	1772

Sigma 900 MAX Refrigerated Discrete Sampler Assembly

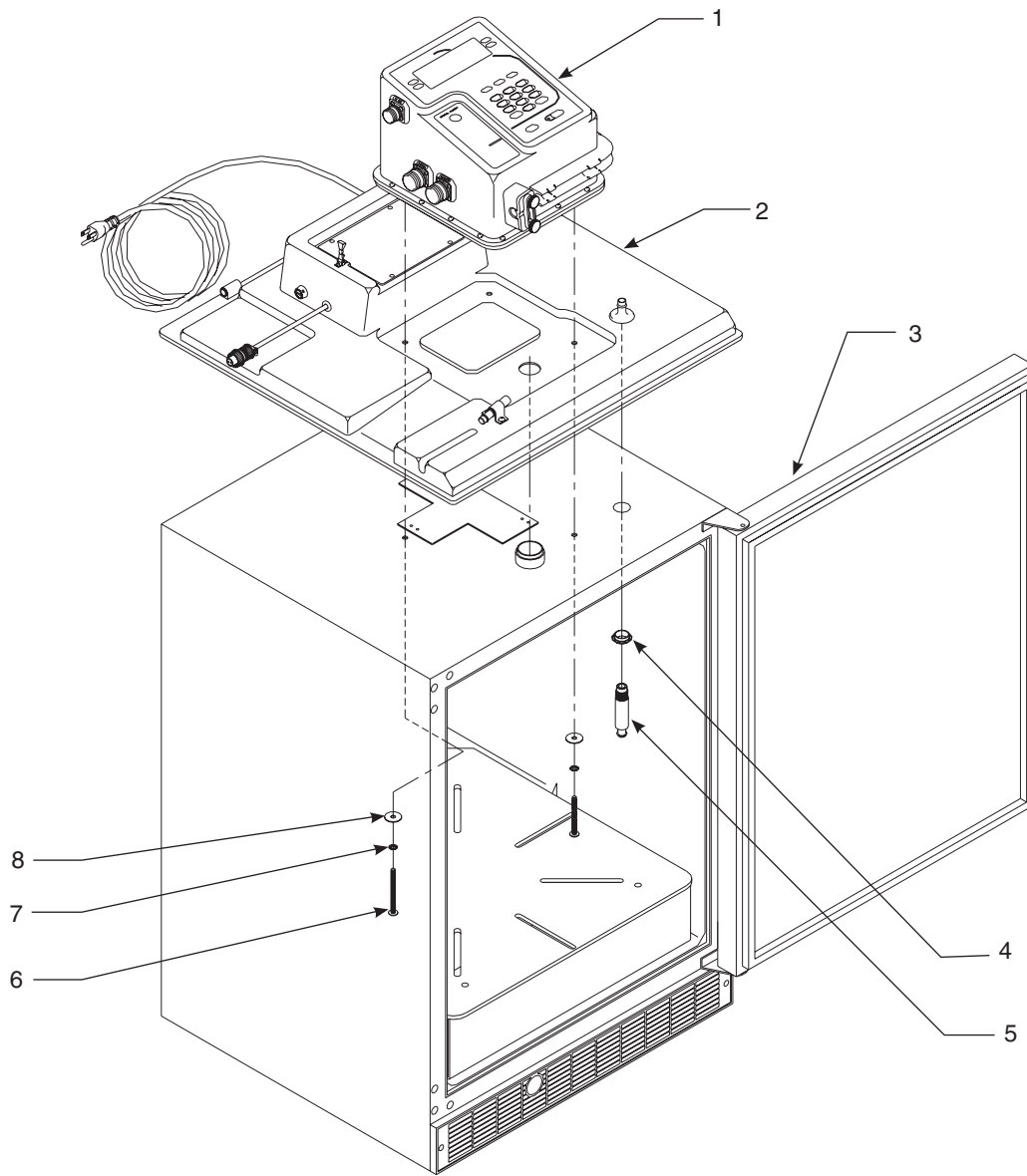

Item	Description	Catalog Number
1	Sigma 900 MAX Refrigerated Sampler	8973
2	120-V Transition Assembly	8924
3	Steel Refrigerator	8959
4	Grommet	2050
5	Sample Extension Fitting	8966
6	Screw	SE 724
7	Lock Washer	SE 708
8	Washer	SE 728



## Sigma 900 Discrete Refrigerator Assembly

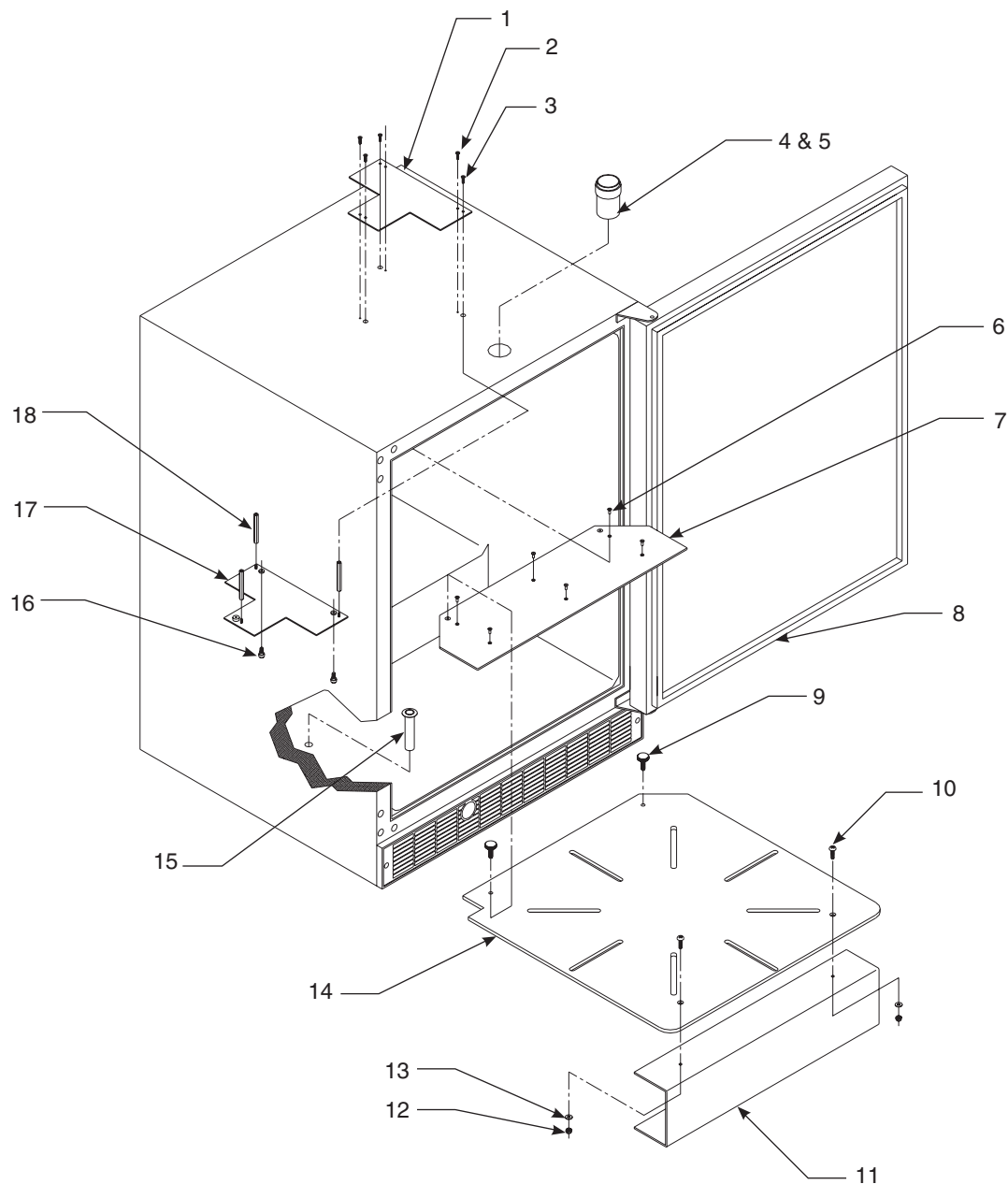

Item	Description	QTY	Cat. No.	Item	Description	QTY	Cat. No.
1	Plate	1	8979	10	Screw	2	SE 534
2	Screw	3	SE 313	11	Support Bracket	1	2135
3	Screw	3	SE 312	12	Nut	2	SE 404
4	Cable Feed-thru Fitting	1	8967	13	Washer	2	SE 503
5	Sealant	1	SE 979	14	8 & 24 Bottle Positioner	1	1512
6	Rivet	6	SE 840	15	Molded Fitting	1	8936
7	Positioner Mounting Plate	1	2136	16	Screw	2	1519
8	Thumbscrew	2	2137	17	Distributor Mounting Plate	1	8978
9	Screw	2	SE 534	18	Standoff	3	1772

Transition Tray Assembly

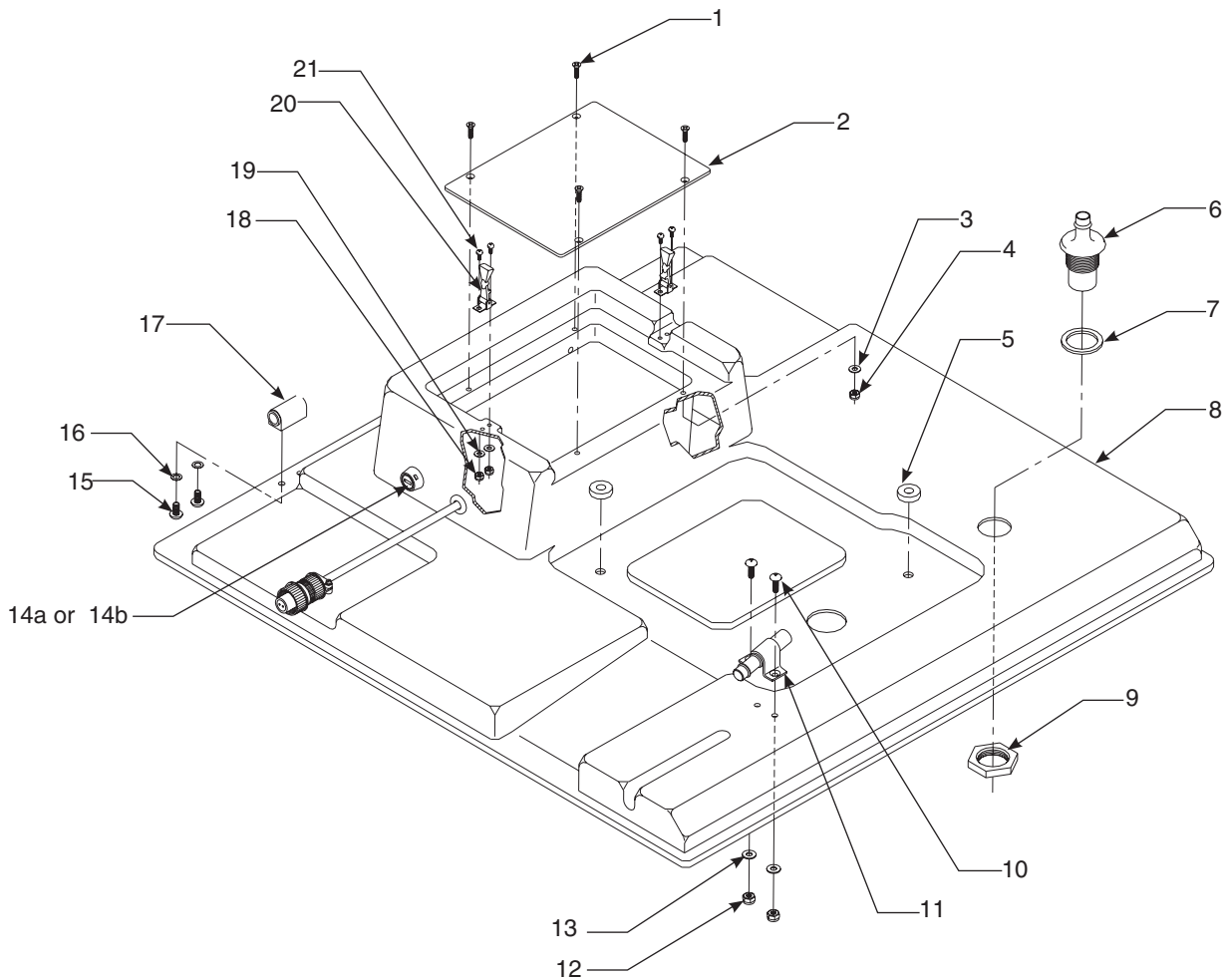

Item	Description	QTY	Cat. No.	Item	Description	QTY	Cat. No.
1	Screw	4	SE 225	12	Washer	2	SE 400
2	Power Supply Plate Cover	1	8939	13	Nut	2	SE 407
3	Washer	4	SE 210	14	Replacement Fuse	1	3231
4	Nut	4	SE 201	15	Screw	4	SE 529
5	Gasket	2	8981	16	Lock Washer	4	SE 501
6	Fitting	1	1794	17	Hinge	2	8941
7	Gasket	1	2885	18	Nut	4	SE 201
8	Transition Plate	1	8892	19	Washer	4	SE 210
9	Nut	1	1429	20	Hold Down Latch	1	1593
10	Screw	2	SE 402	21	Screw	4	SE 215
11	Strain Relief	1	8940				

# Sigma 900 MAX Refrigerated Sampler Reference Dimensions

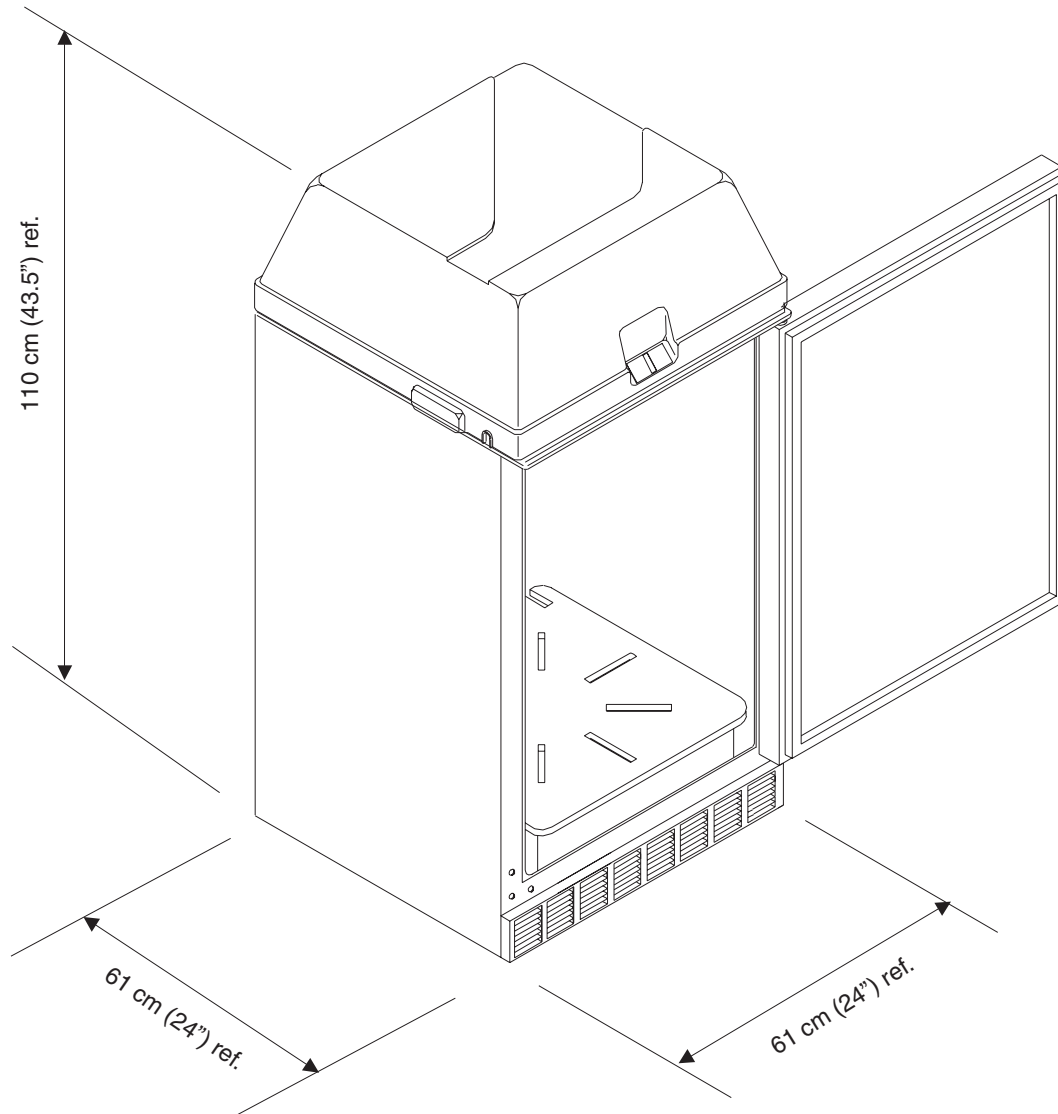





## GENERAL INFORMATION

**At Hach Company, customer service is an important part of every product we make.**

**With that in mind, we have compiled the following information for your convenience.**



Description	Part Number
3-way Splitter Assembly .....	939
4–20 mA Interface, 10 ft Cable.....	2021
Cascade Sampling for 25-ft Cable .....	2817
Cover.....	8963
Desiccant Bag (1 pillow inside case).....	8849
Distributor Arm for 2 and 4 Sampling.....	8569
Distributor Arm for 8 Bottle Sampling.....	8566
Distributor Arm for 24 Bottle Sampling.....	8563
DTU II, 115 V ac .....	3516
DTU II, 230 V ac .....	3517
Flow-thru Module .....	2471
Humidity Indicator .....	2660
Instrument Manual .....	8990
Liquid Level Actuator.....	943
Lockable Hasp .....	2143S
Multi-purpose Full Cable, 10 ft .....	940
Multi-purpose Full Cable, 25 ft .....	540
Multi-purpose Half Cable, 10 ft.....	941
Multi-purpose Half Cable, 25 ft.....	541
Peristaltic Pump Tube Insert .....	8957
Peristaltic Pump Tubing, 15 ft.....	460015
Peristaltic Pump Tubing, 50 ft.....	460050
Peristaltic Pump Tubing for All Distributors and 800 Series, 15 ft .....	386615
Peristaltic Pump Tubing for All Distributors and 800 Series, 50 ft .....	386650
Refrigerator Assembly.....	8959
Refrigerator, 115 V ac, Stainless Steel .....	1030
Refrigerator, 230 V ac, Stainless Steel .....	2188
Sampler Locking Assembly.....	1354
Strainer, All 316 Stainless Steel, 6.0 in. long x 0.406 in. OD .....	2071
Strainer, All 316 Stainless Steel, 7.94 in. long, x 1.0 in. OD .....	2070
Strainer, Stainless Steel, 3.9 in. long x 0.406 in. OD .....	4652
Strainer, Teflon®/Stainless Steel, 5.5 in. long x 0.875 in. OD.....	926
Strainer, Teflon/Stainless Steel, 11.0 in. long x 0.875 in. OD.....	903
Suspension Harness.....	1355
Synchronizing Sampling for 25-ft Cable .....	2818
Teflon-Lined Connection Kit .....	2186
Teflon-lined Tubing, 3/8 in., 10 ft .....	921
Teflon-lined Tubing, 3/8 in., 25 ft .....	922
Teflon-lined Tubing, 3/8 in., 100 ft .....	925
Vinyl Intake Tubing, 3/8 in., 25 ft .....	920
Vinyl Intake Tubing, 3/8 in., 100 ft .....	923
Vinyl Intake Tubing, 3/8 in., 500 ft .....	924

# Parts and Accessories

## Base/Bottle, Composite/Multiple Sampling Accessories

Sampler	Bottle Type	Part Number						
		Bottle	Full Bottle Shut-Off	Tube Support	Extension Tube	Bottle Tray/Positioner	Retainer	Distributor
Composite	2.5 gal Glass	6559	8847	8986	3527	N/A	N/A	N/A
	3 gal Poly.	1918	8847	8986	3527	N/A	N/A	N/A
	6 gal Poly.	6494	8847	8986	N/A	N/A	N/A	N/A
Multiple Bottle	(24) 1 L Poly.	737	N/A	N/A	N/A	1511	1322	8562
	(24) 350 mL Glass	732	N/A	N/A	N/A	1511	1056	8562
	(8) 2.3 L Poly.	657	N/A	N/A	N/A	1511	1322	8565
	(8) 1.9 L Glass	1118	N/A	N/A	N/A	1511	1322	8565
	(4) 2.5 gal Glass	2317	N/A	N/A	N/A	2038	N/A	8568
	(4) 3 gal Poly.	2315	N/A	N/A	N/A	2038	N/A	8568
	(2) 3 gal Poly.	2316	N/A	N/A	N/A	2038	N/A	8568
	(2) 2.5 gal Glass	2318	N/A	N/A	N/A	2038	N/A	8568

## Area x Velocity Measurement Sensors

Option	Description	Part Numbers	
		Connectors	Bare Leads
Standard Submerged Area/Velocity Sensor	Factory Installed Integral Area x Velocity Flow Meter Option <b>Note:</b> Factory Installed Integral Depth Only Flow Meter Option is not available with this option. <b>Note:</b> When ordering flow option and 14.4 modem, flow option must be remote.	4041	4041
	Standard Sensor, Range 0-10 ft (requires cable P/N 3564)	88000	88001
	Standard Sensor, Range 0-30 ft (requires cable P/N 3564)	88002	88003
	Cable, sold by the ft, specify length needed per sensor. Min=10' Max=250'	3564	3564
	Junction Box, required for bare lead sensor connection to flow meter	N/A	4730
	Remote AV, use when the flow meter to sensor distance is greater than 250 ft (requires cable SE818 and sensor).	5250	5250
	Remote AV Cable, sold by the ft, specify length needed per sensor. Min=10' Max=1,000'	SE818	SE818
Keppler Submerged Area/Velocity Sensor <b>Note:</b> For cleaner water/few particulates.	Factory Installed Integral Area x Velocity Flow Meter Option <b>Note:</b> Factory Installed Integral Depth Only Flow Meter Option is not available with this option. <b>Note:</b> When ordering flow option and 14.4 modem, flow option must be remote.	4041	4041
	Standard Sensor, Range 0-10 ft (requires cable P/N 3564)	88012	88013
	Standard Sensor, Range 0-30 ft (requires cable P/N 3564)	88014	88015
	Cable, sold by the ft, specify length needed per sensor. Min=10' Max=250'	3564	3564
	Junction Box, required for bare lead sensor connection to flow meter	N/A	4730
	Remote AV, use when the flow meter to sensor distance is greater than 250 ft (requires cable SE818 and sensor).	5250	5250
	Remote AV Cable, sold by the ft, specify length needed per sensor. Min=10' Max=1,000'	SE818	SE818



## Depth Measurement Sensors

Option	Description	Part Number
Ultrasonic Sensor 40 kHz	Factory Installed Integral Ultrasonic Flow Meter Option	8851
	40 KHz Range 0-10 ft, with 25-ft cable	3028
	Ultrasonic Sensor with Horn, 40 KHz, with 25-ft cable	4008
	Ultrasonic Sensor, CSA Approved for Class I, Division I, Groups A, B, and D Hazardous Locations; with 50-ft cable	4010
	Ultrasonic Sensor, 40 KHz, Range 0-10 ft, with 25-ft cable with bare lead ends	2653
	Junction Box for ultrasonic sensor conduit installations	3658
Depth Sensor	Factory Installed Depth Only Flow Meter Option <b>Note:</b> <i>Factory Installed Integral Area x Velocity Flow Meter Option is not available with Factory Installed Integral Depth Only Flow Meter Option</i>	8794
	General Purpose Depth Sensor, Range 0-0.576 ft with 25-ft cable	2963
	Range 0-10 ft with 25-ft cable	2343
	Range 0-23 ft with 50-ft cable	2333
<b>Note:</b> <i>Depth sensor cables cannot be extended.</i>		

## Sensor Mounting Hardware

Type	Pipe Diameter (Inches)	Part Number	
		Mounting Ring/Band	Mounting Clip
Submerged Area/Velocity Sensor Mounting Rings For 6-24 in. Pipes	6	1361	3263
	8	1362	3263
	10	1363	3263
	12	1364	N/A
	15	1365	N/A
	18	1366	N/A
	20-21	1353	N/A
	24	1370	N/A
Submerged Depth/Veloccity Mounting Bands for 15-42 in. Pipes	15	9706100	N/A
	18	9706200	N/A
	21	9706300	N/A
	24	9706400	N/A
	27	9706500	N/A
	30	9706600	N/A
	33	9706700	N/A
	36	9706800	N/A
	42	9706900	N/A
Submerged Depth Only Sensor Mounting Ring for 6-24 in. Pipes	6	1361	1771
	8	1362	1771
	10	1363	1771
	12	1364	1771
	15	1365	1771
	18	1366	1771
	20-21	1353	1771
	24	1370	1771

## Parts and Accessories

Submerged Depth Only Sensor Mounting Band for 15–42 in. Pipes	15	9706100	1771
	18	9706200	1771
	21	9706300	1771
	24	9706400	1771
	27	9706500	1771
	30	9706600	1771
	33	9706700	1771
	36	9706800	1771
	42	9706900	1771

Option	Description	Part Number
Insertion Tool	To remove P/N 1361–1370 mounting rings.	9574

### Mounting Plate Hardware for Directly Mounting to Pipe Wall

Option	Pipe Diameter	Part Number
Submerged Depth/Velocity Mounting Plate	All Pipe Sizes	4939
Submerged Depth Only Mounting Plate	All Pipe Sizes	2312

### Ultrasonic Sensor Mounting Hardware

Part Description	Part Number
Permanent Wall Mounting Bracket	2974
Adjustable for Floor or Wall	2904
Tripod with Mounting Bracket for Sensor	9538
Cable Straightener	2883
Cable Grip (Requires P/N 2883)	3183

# Contact Information for U.S.A. and Outside Europe

---

## Ordering Information for the U.S.A.

**By Telephone:**  
(800) 635-4567

**By Fax:**  
(970) 461-3915

**Ordering information by E-mail:**  
orders@hach.com

**By Mail:**  
Hach Company  
P.O. Box 389  
Loveland, Colorado 80539-0389  
U.S.A

### Information Required

- Hach account number (if available)
- Your name and phone number
- Purchase order number
- Brief description or model number
- Billing address
- Shipping address
- Catalog number
- Quantity

## Ordering Information for Outside the U.S.A. and Europe

Hach Company maintains a worldwide network of dealers and distributors. To locate the representative nearest you, send E-mail to [intl@hach.com](mailto:intl@hach.com) or visit [www.hach.com](http://www.hach.com).

## Technical Support

Technical and Customer Service Department personnel are eager to answer questions about our products and their use. In the U.S.A., call 1-800-635-1230. Outside the U.S.A. and Europe, send E-mail to [intltech@hach.com](mailto:intltech@hach.com).

## Repair Service

Authorization must be obtained from Hach Company before sending any items for repair. Please contact the Hach Company Service Center serving your location.

Hach Company  
P.O. Box 389  
Loveland, Colorado, 80539-0389 U.S.A.

Telephone: 1-800-635-1230 or (970) 669-3050

Fax: (970) 669-2932

# Contact Information for Europe

---

For technical support, repair service, and ordering information please refer to the contact information below for your specific country.

## Belgium

Lange Group  
Ragheno Business Center 2  
Motstraat 54  
B-2800 Mechelen  
Tel.: ++32/(0)15 42/ 35 00  
Fax: ++32/(0)15 41/ 61 20  
email: info@langegroup.be

## Germany (TCS & Service)

Dr. Bruno Lange GmbH & CO. KG  
Willstätterstr. 11  
D-40549 Düsseldorf  
Tel.: ++49/(0)211/52 88-0  
Fax: ++49/(0)211/52 88-143  
email: kundenservice@drlange.de  
www.drlange.com

## Spain

NEURTEK. M.A-LANGE GROUP  
c/ Araba, 45.  
Apdo. 220  
E-20800 ZARAUZ  
Tel.: ++34 943 894.379  
Fax: ++ 34 943 130.241  
email: info@drlange.com  
www.drlange.com

## Great Britain

Dr. Lange (UK) Ltd.  
Lennox Road  
GB-Basingstoke  
Hampshire  
RG22 4AP  
Tel.: ++44/(0)12 56/ 33 34 03  
Fax: ++44/(0)12 56/ 33 07 24  
email: info@drlange.co.uk  
www.drlange.co.uk

## Sweden

Dr. Lange AB  
LAB Products  
Box 9008  
S-40091 Göteborg  
Tel.: ++46-31-28 50 50  
Fax: ++46-31-28 50 39  
email: info@lange.se  
www.lange.se

## Denmark

Dr. Lange Danmark A/S  
Jernhoolmen 34-40  
DK-2650 Hvidovre  
Tel.: ++45/(0)36 77/ 2911  
Fax: ++45/(0)36 77/ 4911  
email: drlange@drlange.dk  
www.drlange.de

## Germany (Ordering)

Dr. Bruno Lange GmbH & CO. KG  
Königsweg 10  
D-14163 Berlin  
Tel.: ++49/(0)30/80 98 60  
Fax: ++49(0)30/80 98 62 70  
www.drlange.de

## France

Polymetron/Dr. Lange  
Division Lab  
33 rue du ballon  
F-93165 Noisy le Grand  
Tel.: ++33/(0)1/ 48 15 68 70  
Fax: ++33/(0)1/ 48 15 68 79  
email: info@drlange.fr  
www.drlange.fr

## The Netherlands

Dr. Lange Benelux  
Postbus 6299  
NL-4000 HG Tiel  
Tel.: ++31/(0)344/ 63 11 30  
Fax: ++31/(0)344/ 63 11 50  
email: info@langegroup.nl  
www.langegroup.nl

## Sweden

Dr. Lange AB  
PROCESS Products  
Box 410  
S-13525 Tyresö  
Tel.: ++46-87-98 05 00  
Fax: ++46-87-42 17 24  
email: info@lange.se  
www.lange.se

## Poland

Dr. Lange Sp. z o.o.  
ul. Opolska 143a  
PL-52-013 Wroclaw  
Tel.: ++48/(0)71/ 3 42 10 -81/-83  
Fax: ++48/(0)71/ 3 42 10 79  
email: mail@drlange.pl  
www.drlange.de

## Austria

Dr. Bruno Lange Ges.m.b.H.  
Industriestraße 12  
A - 3200 Obergrafendorf  
Tel.: ++43/(0)2747 - 7412  
Fax: ++43/(0)2747 - 4218  
email: lange@via.at  
www.drlange.de

## Italy

Dr. Bruno Lange s.r.l.  
via Riccione, 14  
IT-20156 Milano  
Tel.: ++39/(0)2 39 23 14 1  
Fax: ++33/(0)2 39 23 14 39  
email: info@drlange.it  
www.drlange.it

## Switzerland

Dr. Bruno Lange AG  
Juchstrasse 1  
CH-8604 Hegnau  
Tel.: ++41/(0)1/ 9 45 66 10  
Fax: ++41/(0)1/ 9 45 66 76  
email: info@drlange.ch  
www.drlange.ch

Hach Company warrants this product to the original purchaser against any defects that are due to faulty material or workmanship for a period of one year from date of shipment.

In the event that a defect is discovered during the warranty period, Hach Company agrees that, at its option, it will repair or replace the defective product or refund the purchase price, excluding original shipping and handling charges. Any product repaired or replaced under this warranty will be warranted only for the remainder of the original product warranty period.

This warranty does not apply to consumable products such as chemical reagents; or consumable components of a product, such as, but not limited to, lamps and tubing.

Contact Hach Company or your distributor to initiate warranty support. Products may not be returned without authorization from Hach Company.

## Limitations

This warranty does not cover:

- Damage caused by acts of God, natural disaster, labor unrest, acts of war (declared or undeclared), terrorism, civil strife or acts of any governmental jurisdiction
- Damage caused by misuse, neglect, accident or improper application or installation
- Damage caused by any repair or attempted repair not authorized by Hach Company
- Any product not used in accordance with the instructions furnished by Hach Company
- Freight charges to return merchandise to Hach Company
- Freight charges on expedited or express shipment of warranted parts or product
- Travel fees associated with on-site warranty repair

This warranty contains the sole express warranty made by Hach Company in connection with its products. All implied warranties, including without limitation, the warranties of merchantability and fitness for a particular purpose, are expressly disclaimed.

Some states within the United States do not allow the disclaimer of implied warranties and if this is true in your state the above limitation may not apply to you. This warranty gives you specific rights, and you may also have other rights that vary from state to state.

This warranty constitutes the final, complete, and exclusive statement of warranty terms and no person is authorized to make any other warranties or representations on behalf of Hach Company.

## Limitation of Remedies

The remedies of repair, replacement or refund of purchase price as stated above are the exclusive remedies for the breach of this warranty. On the basis of strict liability or under any other legal theory, in no event shall Hach Company be liable for any incidental or consequential damages of any kind for breach of warranty or negligence.

## Numerics

4-20 mA Option .....	87
Calibration .....	88
Connection .....	87
Interface Connector .....	87
Programming .....	87
Pulse Duration Input .....	133

## A

ac Power .....	124
Access Code .....	39
Advanced Sampling .....	49
Program Complete .....	50
Setpoint Sampling .....	50
Special Output .....	52
Start/Stop Times .....	53
Storm Water .....	54
Timed Bottle Sets .....	57
Upset Sample .....	58
Variable Intervals .....	60
Variable Volume .....	60
Alarm .....	91
Alarm Relays .....	89
Connections .....	90
Interface Connector .....	90
Junction Box .....	90
Programming .....	91
Alarms .....	
Deadband .....	92
Set Point Alarms .....	91
Trouble Alarm Troubleshooting .....	129
Trouble Alarms .....	91
Analog Inputs .....	93
Connection .....	93
Programming .....	94
Arm Stop .....	29
Auxiliary Receptacle .....	32

## B

Basic Programming Setup .....	37
Battery Power .....	124
Baud Rate .....	79
Bottle Number .....	53
Bottle Volume .....	38
Bottles .....	26, 38
Bottom Panel .....	100

## C

Calibration .....	
4-20 mA .....	88
Conductivity Probe .....	77
Dissolved Oxygen Probe .....	75

Downlook Ultrasonic Sensor .....	61
ORP Probe .....	73
pH Probe .....	71
Submerged Area/Velocity Sensor .....	64
Submerged Pressure Sensor .....	66
Cellular Communications .....	80
Cellular Modem Scheduling .....	82
Cellular Modem Triggering .....	84
Circuit Board .....	101
Cleaning the Sampler .....	97
Conductivity Probe .....	76
Calibration .....	77
Connection .....	76
Programming .....	76
Temperature Calibration .....	78
Temperature Programming .....	76
Constant Time, Variable Volume Sampling .....	43
Constant Volume, Variable Time .....	41
Continous Mode .....	119
Controller Cover .....	15
Controller, opening .....	99
Controller, removal of .....	99

## D

Data Log .....	119
Deadband .....	92
Desiccant module, internal .....	17, 103
Desiccant module, replacement .....	103
Diagnostics .....	121
Distributor Test .....	122
Event Log .....	122
Keypad Test .....	122
LCD Test .....	123
Liquid Sensor .....	123
Velocity Analysis .....	123
Displaying Data .....	113
Dissolved Oxygen Probe .....	
Calibration .....	75
Connection .....	74
Membrane Thickness .....	75
Programming .....	74
Strain Relief .....	74
Temperature Calibration .....	75
Temperature Programming .....	75
Distributor .....	
Arm Alignment .....	30
Installation .....	29
Downlook Ultrasonic Sensor .....	
Calibration .....	61
Connection .....	61
Programming .....	61
DTU-II .....	79

<b>E</b>		
Eight-, 12-, or 24-bottle Sampling .....	28	
Electrostatic Discharge .....	99	
Error Messages .....	127	
Extended Power Mode .....	119	
<b>F</b>		
First Flush Bottles .....	55	
Flow Totalizer .....	125	
Flow Units .....	42, 125	
Front Panel .....	15	
Full-Bottle Shut-Off .....	31	
Function Keys .....	16	
Fuse Replacement .....	103	
<b>G</b>		
Graph Manipulation .....	115	
Graphic Display Averaging .....	115	
Graphs .....	114	
<b>H</b>		
Humidity Indicator .....	17	
<b>I</b>		
Installation site .....	23	
Intake Line .....	25, 26	
Intake Rinses .....	48	
Intake Tubing .....	39	
Interface Connectors .....	18	
Invisible Range .....	62	
<b>K</b>		
Keypad .....	16	
<b>L</b>		
Level Adjust .....	65, 67	
Liquid Crystal Display .....	16	
Liquid Depth .....	61	
Liquid Sensor .....	19, 47	
Load Program .....	124	
Logging Intervals .....	119	
Lubrication .....	97	
<b>M</b>		
Maintenance .....	97	
Memory Allocation .....	120	
Memory Battery .....	86, 104, 129	
Memory Modes .....	120	
Menu Bar and Status Bar .....	16	
Modem		
Connection .....	80	
Programming .....	80	
Modify Setup .....	125	
Motor/Gear Box .....	103	
Multiple Bottle .....	45	
<b>N</b>		
Numeric Keypad .....	16	
<b>O</b>		
ON/OFF Key .....	16	
Option Menu .....	116	
ORP Probe		
Calibration .....	73	
Junction Box .....	73	
Junction Box Calibration .....	73	
Programming .....	73	
<b>P</b>		
Pager Alarm Codes .....	86	
Pager Option .....	84	
Password .....	39	
pH Probe		
Calibration .....	71	
Connection .....	70	
Junction Box (grounded) .....	71	
Junction Box (un-grounded) .....	71	
Programming .....	71	
Troubleshooting .....	131	
Pin .....	32	
Power Connectors .....	31	
Power connectors .....	31	
Power Save Mode .....	119	
Program Delay .....	40	
Program Lock .....	39	
Pulses/Counts .....	133	
Pump Tube		
Installation .....	24, 26	
Pump Tube Replacement .....	98	
Pump tube, installation .....	24	
<b>Q</b>		
Quick Start Guides .....	105	
<b>R</b>		
Rain Gauge .....	69	
Connection .....	69	
Programming .....	70	
Tipping Bucket .....	69	
RAM .....	120	

# Index

---

Receptacle Caps .....	18
Reliable Communications .....	82
Reporting Devices .....	85
Reset (Totalizer) .....	126
Retainers .....	26
Review All Items .....	113
RS232	
Connection .....	79
Programming .....	79
Running a Program .....	113

## S

Sample Collection .....	40
Sample Distribution .....	45
Multiple Bottle .....	45
Single Bottle .....	45
Sample History .....	115
Sample Retries .....	48
Sample Volume .....	48
Sample, retry .....	20
Sampling Triggers and Settings .....	52
Screen Saver Mode .....	124
Sensor Body .....	24
Sensor Height .....	62
Set Point Alarms .....	91
Setpoint Sampling .....	50
Single Bottle Sampling .....	27
Single-Bottle Sampling .....	45
Site Selection .....	81
Site selection .....	23
Slate Mode .....	121
Soft Keys .....	16
Specifications .....	9
Splitter Interface .....	33

Status .....	37
Strain Relief .....	74
Strainer .....	26
Submerged Area Velocity Sensor .....	63
Cable Routing .....	63
Calibration .....	64
Connection .....	63
Programming .....	63
Submerged Pressure Sensor .....	65
Calibration .....	66
Connection .....	65
Programming .....	66

## T

Tables .....	114
Time/Date .....	116
Timed Over-Ride .....	42
Timed Proportional Sampling .....	40
Trouble Alarms	
Troubleshooting .....	129
Trouble Condition .....	91
Troubleshooting .....	127
Tubing, pre-rinse .....	20
Two- and Four-bottle Sampling .....	27

## U

Utility Board .....	102
---------------------	-----

## V

Vertical Lift .....	10
Vinyl Tubing .....	25
Volume Calibration .....	116

## W

Wrap Mode .....	121
-----------------	-----



## Free Manuals Download Website

<http://myh66.com>

<http://usermanuals.us>

<http://www.somanuals.com>

<http://www.4manuals.cc>

<http://www.manual-lib.com>

<http://www.404manual.com>

<http://www.luxmanual.com>

<http://aubethermostatmanual.com>

Golf course search by state

<http://golfingnear.com>

Email search by domain

<http://emailbydomain.com>

Auto manuals search

<http://auto.somanuals.com>

TV manuals search

<http://tv.somanuals.com>