

High Sanitation Pumps

310622L

For use in sanitary applications.

Models 1590 & 3150 SA__ Sanitary Diaphragm Pump 

Models 1590 & 3150 SB__ Sanitary Ball Check Pump 

Model 3150 SF__ Sanitary Flapper Check Pump 

120 psi (0.8 MPa, 8 bar) Maximum Fluid Working Pressure

120 psi (0.8 MPa, 8 bar) Maximum Air Input Pressure



Important Safety Instructions.

Read all warnings and instructions in this manual. Save these instructions.

See page 2 for Table of Contents.

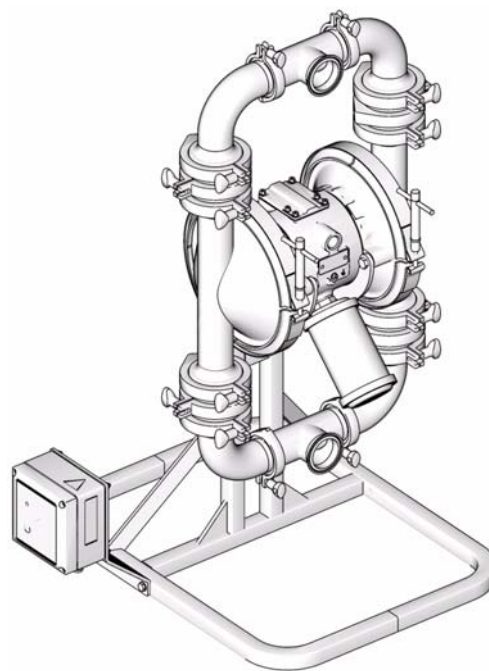

Model SA3AAA Shown

T18760a

US and Foreign Patents Pending
US Patent No. 5,368,452

PROVEN QUALITY. LEADING TECHNOLOGY.

Graco Inc. P.O. Box 1441 Minneapolis, MN 55440-1441
Copyright 2004, Graco Inc. is registered to I.S. EN ISO 9001



Contents





Warning	3	Model 1590	33
Installation	5	Dimensional Drawing	33
Operation	10	Technical Data	34
Maintenance	11	Performance Chart	35
Troubleshooting	14	Model 3150	36
Service	16	Dimensional Drawing	36
Pump Matrix	25	Technical Data	37
Parts	26	Performance Chart	38
Accessories	32	Graco Warranties	40
3150 Conversion Kits	32	Graco Information	40







Models

Refer to page 25 to determine the model number of your pump.

Warnings

The following general warnings are for the safe setup, use, grounding, maintenance, and repair of this equipment. The exclamation point symbols alert you to general warnings and the hazard symbols refer to procedure-specific risks. Refer back to these Warnings. Additional, product-specific warnings may be found throughout the body of this manual where applicable.

 Warning	
	<p>FIRE AND EXPLOSION HAZARD</p> <p>Flammable fumes, such as solvent and paint fumes, in work area can ignite or explode. To help prevent fire and explosion:</p> <ul style="list-style-type: none"> • Use equipment only in well ventilated area. • Eliminate all ignition sources; such as pilot lights, cigarettes, portable electric lamps, and plastic drop cloths (potential static arc). • Keep work area free of debris, including solvent, rags and gasoline. • Do not plug or unplug power cords, or turn power or light switches on or off when flammable fumes are present. • Ground equipment and conductive objects in work area. See Grounding instructions. • Use only grounded hoses. • Hold gun firmly to side of grounded pail when triggering into pail. • If there is static sparking or you feel a shock, stop operation immediately. Do not use equipment until you identify and correct the problem.
	<p>PRESSURIZED EQUIPMENT HAZARD</p> <p>Fluid from the gun/dispense valve, leaks, or ruptured components can splash in the eyes or on skin and cause serious injury.</p> <ul style="list-style-type: none"> • Follow Pressure Relief Procedure in this manual, when you stop operating and before cleaning, checking, or servicing equipment. • Tighten all fluid connections before operating the equipment. • Check hoses, tubes, and couplings daily. Replace worn or damaged parts immediately.
	<p>EQUIPMENT MISUSE HAZARD</p> <p>Misuse can cause death or serious injury.</p> <ul style="list-style-type: none"> • Do not exceed the maximum working pressure or temperature rating of the lowest rated system component. See Technical Data in all equipment manuals. • Use fluids and solvents that are compatible with equipment wetted parts. See Technical Data in all equipment manuals. Read fluid and solvent manufacturer's warnings. • Check equipment daily. Repair or replace worn or damaged parts immediately with genuine Graco replacement parts only. • Do not alter or modify equipment. • For professional use only. • Use equipment only for its intended purpose. Call your Graco distributor for information. • Route hoses and cables away from traffic areas, sharp edges, moving parts, and hot surfaces. • Do not use hoses to pull equipment. • Comply with all applicable safety regulations.
	<p>TOXIC FLUID OR FUMES HAZARD</p> <p>Toxic fluids or fumes can cause serious injury or death if splashed in the eyes or on skin, inhaled, or swallowed.</p> <ul style="list-style-type: none"> • Read MSDS's to know the specific hazards of the fluids you are using. • Store hazardous fluid in approved containers, and dispose of it according to applicable guidelines.

 Warning	
	<p>BURN HAZARD</p> <p>Equipment surfaces and fluids that are heated can become very hot during operation. To avoid severe burns, do not touch hot fluid or equipment. Wait until equipment/fluid has cooled completely.</p>
   	<p>PERSONAL PROTECTIVE EQUIPMENT</p> <p>You must wear appropriate protective equipment when operating, servicing, or when in the operating area of the equipment to help protect you from serious injury, including eye injury, inhalation of toxic fumes, burns, and hearing loss. This equipment includes but is not limited to:</p> <ul style="list-style-type: none">• Protective eyewear• Clothing and respirator as recommended by the fluid and solvent manufacturer• Gloves• Hearing protection

Installation

General Information

- The typical installation shown in FIG. 3 is only a guide for selecting and installing system components. Contact your Graco distributor for assistance in planning a system to suit your needs.
- Always use genuine Graco parts and accessories.
- Reference numbers and letters in parentheses refer to the callouts in the figures and the parts lists on pages 26 - 31.

<p>The pump is very heavy (see Technical Data on pages 34 and 37 for specific weights). If the pump must be moved, follow the Pressure Relief Procedure on page 10 and have two people lift the pump by grasping the outlet manifold securely, or use appropriate lifting equipment. Never have one person move or lift the pump.</p>							

Leak Detection System

A leak detection system will be included with all approved pumps. See manual 311200 included with leak detector for leak detector installation instructions.

Tighten Clamps Before First Use

After you unpack the pump, and before you use it for the first time, check all clamps, and tighten as necessary.

Stand

See pages 30 and 31 for parts.

1. Place the stand assembly on a level surface.
2. Mount the pump securely to the brackets using bolts (659).
3. Tighten the bolts (V) to hold the slotted bracket in place. See FIG. 1.

Bolts (V) must be tightened to hold the bracket in place during operation.

<p>Moving Parts Hazard Keep clear of moving parts.</p>							

Bolts (V) may be loosened to allow the pump, while still securely mounted to the bracket, to be rotated for draining or servicing.

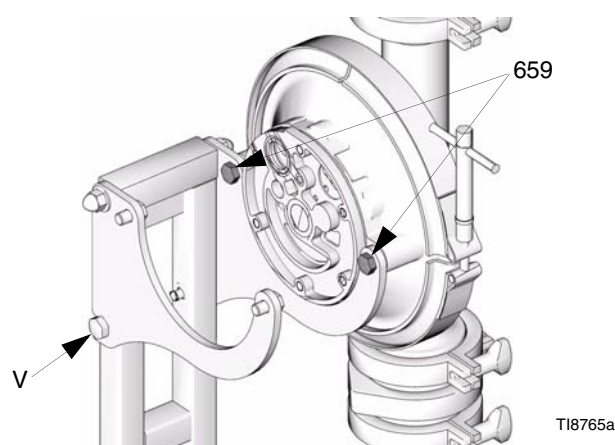

FIG. 1

Grounding

To reduce the risk of static sparking, ground the pump and all other equipment used or located in the pumping area. Check your local electrical code for detailed grounding instructions for your area and type of equipment.

--	--	--	--	--	--	--	--

- **Pump:** Connect a ground wire and clamp as shown in FIG. 2. Loosen the grounding screw (W). Insert one end of a 12 ga (1.5 mm²) minimum ground wire (X) behind the grounding screw and tighten the screw securely. Connect the clamp end of the ground wire to a true earth ground. To order a ground wire and clamp, order part number 222011.

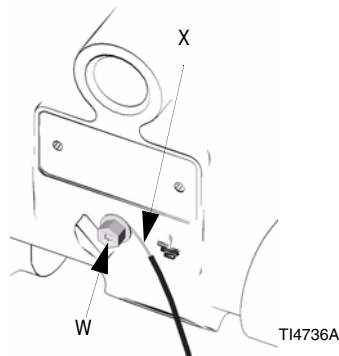

Ground Wire Connection

FIG. 2

- *Air and fluid hoses:* Use only grounded hoses with a maximum of 500 ft (150 m) combined hose length to ensure grounding continuity.
- *Air compressor:* Follow the manufacturer's recommendations.
- *Fluid supply container:* Follow the local code.

Mountings

CAUTION
The pump exhaust air may contain contaminants. Ventilate to a remote area if the contaminants could affect your fluid supply. See Air Exhaust Ventilation on page 8.

- Be sure the mounting surface can support the weight of the pump, hoses, and accessories, as well as the stress caused during operation.
- For ease of operation and service, mount the pump so the air valve cover (2), air inlet, and fluid inlet and outlet ports are easily accessible.

Air Line

A bleed-type master air valve (B) is required in the system to relieve air trapped between this valve and the pump. Trapped air can cause the pump to cycle unexpectedly, which could result in serious injury including splashing in the eyes or on the skin, injury from moving parts, or contamination from hazardous fluids. See FIG. 3.						

1. Install the air line accessories as shown in FIG. 3. Mount these accessories on the wall or on a bracket. Be sure the air line supplying the accessories is grounded.
 - a. Install an air regulator (C) and gauge to control the fluid pressure. The fluid outlet pressure will be the same as the setting of the air regulator.
 - b. Locate one bleed-type master air valve (B) close to the pump and use it to relieve trapped air. Locate the other master air valve (E) upstream from all air line accessories and use it to isolate them during cleaning and repair.
 - c. The air line filter (F) removes harmful dirt and moisture from the compressed air supply.
2. Install a grounded, flexible air hose (A) between the accessories and the 1/2 npt(f) pump air inlet (M). Use a minimum 3/8 in. (9.5 mm) ID air hose. Screw an air line quick disconnect coupler (D) onto the end of the air hose (A), and screw the mating fitting into the pump air inlet snugly.

Do not connect the coupler (D) to the fitting until you are ready to operate the pump. Connecting the coupler too early can result in unintentional operation of the pump, leading to serious injury from to moving parts, splashing fluid in the eyes or on the skin, and contact with hazardous fluids.						

Fluid Suction Line

--	--	--	--	--	--	--

1. Use flexible, grounded fluid hoses (G) where possible.
2. For best sealing results, use a standard Tri-Clamp® style sanitary gasket of a flexible material such as EPDM, Buna-N, fluoroelastomer, or silicon.
3. If the fluid inlet pressure to the pump is more than 25% of the outlet working pressure, the ball check valves will not close fast enough, resulting in inefficient pump operation.

- At inlet fluid pressures greater than 15 psi (0.1 MPa, 1 bar), diaphragm life will be shortened.

- See the **Technical Data** on pages 34 and 37 for maximum suction lift (wet and dry).

Fluid Outlet Line



A fluid drain valve (J) is required to relieve pressure in the hose if it is plugged. The drain valve reduces the risk of serious injury, including splashing in the eyes or on the skin, or contamination from hazardous fluids when relieving pressure. Install the valve close to the pump fluid outlet. See FIG. 3.

- Use flexible, grounded fluid hoses (L) where possible.
- For best sealing results, use a standard Tri-Clamp® style sanitary gasket of a flexible material such as EPDM, Buna-N, fluoroelastomer, or silicon
- Install a fluid drain valve (J) near the fluid outlet. See FIG. 3.
- Install a shutoff valve (K) in the fluid outlet line.

Typical Installation

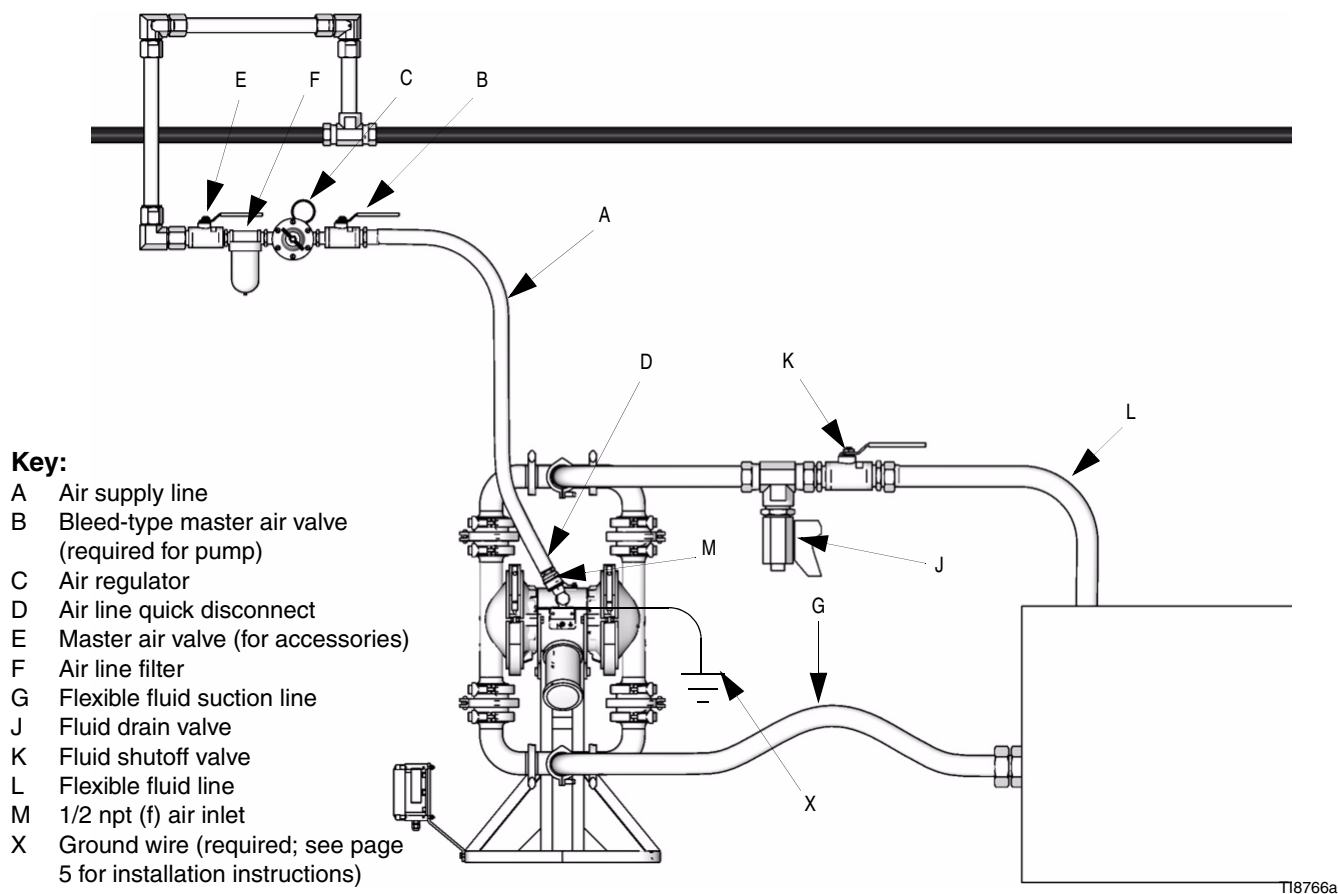

FIG. 3 Typical Floor-Mount Installation

Changing the Orientation of the Fluid Inlet and Outlet Ports

The pump is shipped with the ports facing the same direction. To re-orientate the ports into any position:

1. Remove the clamps (130) holding the inlet and/or outlet tee to the elbows.
2. Rotate the manifold tee (339) and reattach. Install the clamps (130) and tighten handtight.

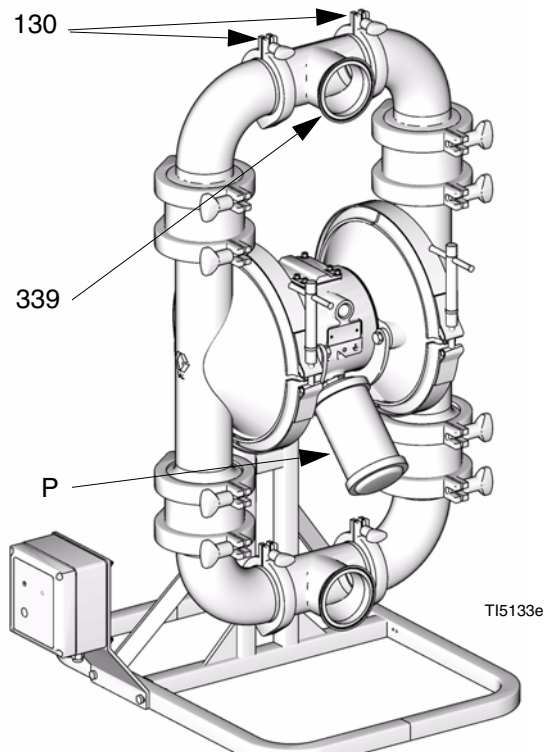

FIG. 4 Orientation of Fluid Ports

Air Exhaust Ventilation



Be sure the system is properly ventilated for your type of installation. You must vent the exhaust to a safe place, away from people, animals, food handling areas, and all sources of ignition when pumping flammable or hazardous fluids.

Diaphragm failure can cause the fluid being pumped to exhaust with the air. Place an appropriate container at the end of the air exhaust line to catch the fluid. See FIG. 5.

The air exhaust port is 3/4 npt(f). Do not restrict the air exhaust port. Excessive exhaust restriction can cause erratic pump operation.

To provide a remote exhaust:

1. Remove the muffer (P) from the pump air exhaust port. See FIG. 5.
2. Install a grounded air exhaust hose (T) and connect the muffer (P) to the other end of the hose. The minimum size for the air exhaust hose is 3/4 in. (19 mm) ID. If a hose longer than 15 ft (4.57 m) is required, use a larger diameter hose. Avoid sharp bends or kinks in the hose.
3. Place a grounded container (U) at the end of the air exhaust line to catch fluid in case of a diaphragm rupture. See FIG. 5.

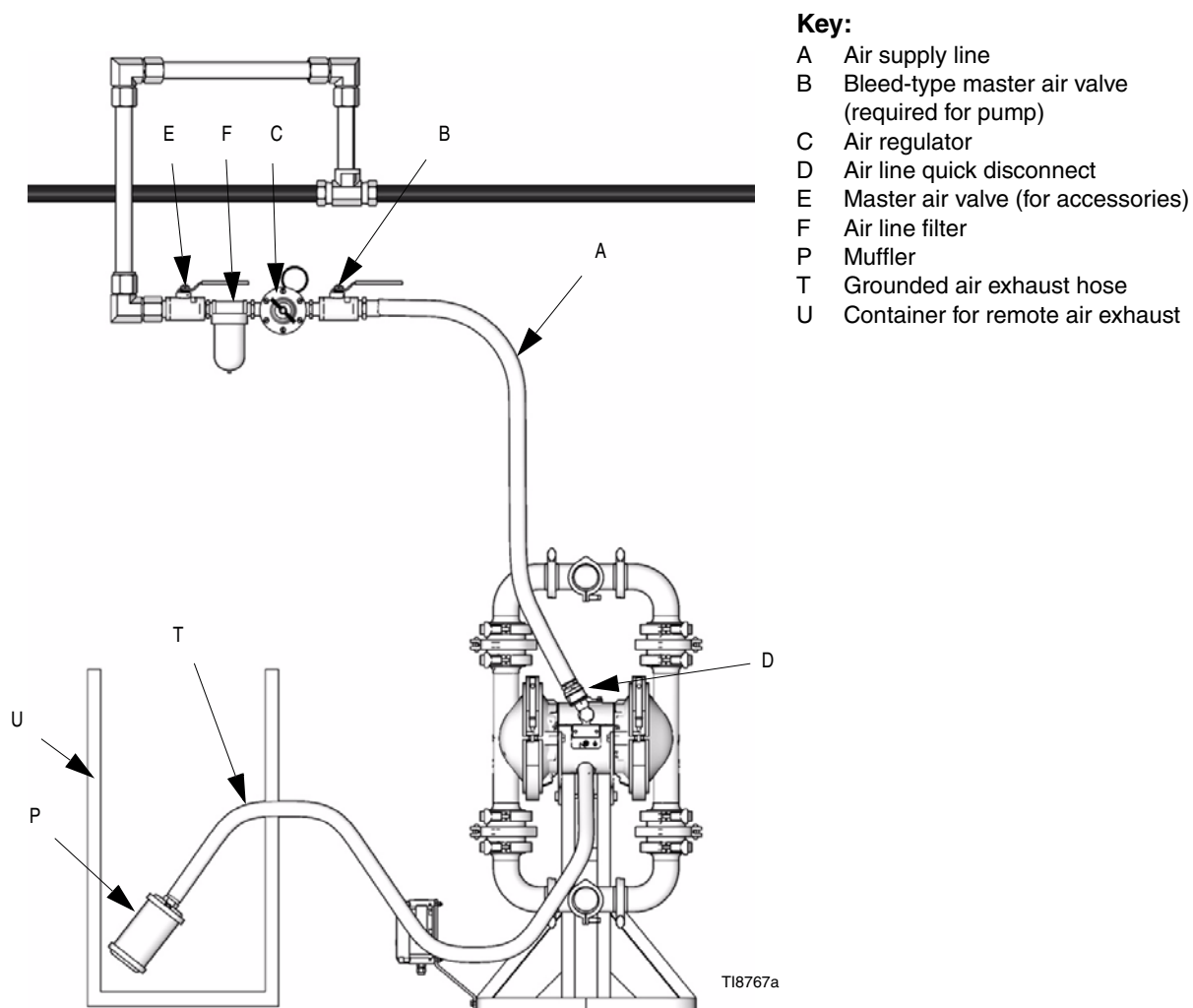

FIG. 5 Venting Exhaust Air

Operation

Pressure Relief Procedure



1. Shut off the air to the pump.
2. Open any available outbound fluid valve to relieve fluid pressure from the pump.
3. If fluid is still in the outbound fluid lines, isolate this fluid as follows:
 - a. Close the outbound fluid valves.
 - b. Slowly remove the fluid connections from the pump, and have a container ready to catch any fluid that runs out.

Sanitizing the Pump Before First Use

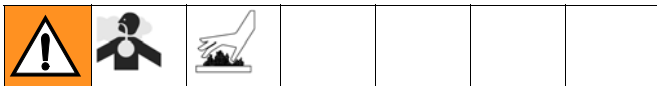

 The pump was built and tested using a food grade lubricant.

It is the user's responsibility to properly sanitize the pump before first use. It is up to the user whether this will include disassembling and cleaning individual parts or simply flushing pump with a sanitizing solution. As necessary, follow the steps under **Starting and Adjusting the Pump** below, under **Flushing** on page 11, or under **Disassembly** in the **Service** section on pages 19, 21.

Starting and Adjusting the Pump

1. Be sure the pump is properly grounded. Refer to **Grounding** on page 5.

2. Check connections to be sure they are tight. Tighten fluid inlet and outlet connections securely.
3. Place the suction tube (if used) in fluid to be pumped.



If fluid inlet pressure to the pump is more than 25% of the outlet working pressure, the ball check valves will not close fast enough, resulting in inefficient pump operation.

4. Place the end of fluid hose (L) into an appropriate container.
5. Close the fluid drain valve (J).
6. Back out the air regulator (C) knob, and open all bleed-type master air valves (B, E).
7. If the fluid hose has a dispensing device, hold it open while continuing with the following step.
8. Slowly increase air pressure with the air regulator (C) until the pump starts to cycle. Do not exceed the maximum operating air pressure as listed in the Technical Data section on pages 34 and 37. Allow the pump to cycle slowly until all air is pushed out of the lines and the pump is primed.

Pump Shutdown



At the end of the work shift, relieve pressure.

Maintenance

Lubrication

The air valve is designed to operate unlubricated, however if lubrication is desired, every 500 hours of operation (or monthly) remove the hose from the pump air inlet and add two drops of machine oil to the air inlet.

CAUTION

Do not over-lubricate the pump. Oil is exhausted through the muffler and could contaminate your fluid supply or other equipment. Excessive lubrication can also cause the pump to malfunction.

Flushing



Insert suction tube into cleaning solution. Open air regulator to supply low pressure air to the pump. Run the pump long enough to thoroughly clean the pump and hoses. Close the air regulator. Remove the suction tube from the cleaning solution and drain pump. Place suction tube in the fluid to be pumped.

Flush the pump often enough to prevent the fluid you are pumping from drying or freezing in the pump and damaging it. Flushing schedule will be based on what the pump is being used for. Use a compatible cleaning solution and always cycle the pump during the entire flushing process.

Always flush the pump and relieve the pressure before storing it for any length of time.

Routine Cleaning of Product Contact Section of Pump



The pump and the system should be cleaned in accordance with your state sanitary standard codes and local regulations.

1. Flush the system. See **Flushing** above.
2. Relieve pressure in the system. See **Pressure Relief Procedure** on page 10.
3. Disassemble the fluid section of the pump and accessories. See **Check Valve Repair** on page 19 and **Diaphragm Repair** on page 21.
4. Using a brush or other C.I.P. methods, wash all product contact pump parts with an alkaline detergent at the manufacturer's recommended temperature and concentration.
5. Rinse these parts again with water and allow parts to completely dry.
6. Inspect the parts and reclean any soiled parts.
7. Immerse all product contact parts in an approved sanitizer before assembly. Leave the parts in the sanitizer, taking them out only one by one as needed for assembly. See **Check Valve Repair** on page 19 and **Diaphragm Repair** on page 21.
8. Lubricate the clamps, clamping surfaces, and gaskets with waterproof sanitary lubricant.
9. Circulate the sanitizing solution through the pump and the system prior to use. Cycle the pump as the sanitizing solution is circulated.

Tightening Connections

Before each use, check all hoses for wear or damage, and replace as necessary. Check to be sure all connections are tight and leak-free.

Preventive Maintenance Schedule

Establish a preventive maintenance schedule based on the pump's service history. This is especially important for prevention of spills or leakage due to diaphragm failure.

The following is a list of recommended maintenance procedures and frequencies to operate your equipment safely. Maintenance must be performed by trained personnel per this schedule to assure safety and reliability of the equipment.

Task	Operator	Maintenance Person	
	Daily	Weekly	Monthly
Inspect system for leaks	✓		
Depressurize fluid, after operation	✓		
Remove heat from system, after operation	✓		
Inspect diaphragm for wear	✓		
Inspect check valve components for wear	✓		
Check hoses for wear		✓	
Check/tighten fluid connections		✓	
Check/tighten air connections		✓	
Lubricate air valves			✓

Troubleshooting

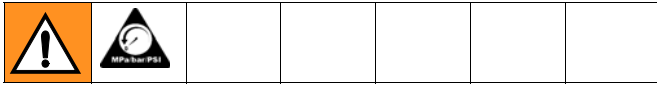

- Relieve the pressure before checking or servicing the equipment.
- Check all possible problems and causes before disassembling the pump.

PROBLEM	CAUSE	SOLUTION
Pump cycles at stall or fails to hold pressure at stall.	Worn check valve balls (541) or seats (233).	Replace. See page 19.
Pump will not cycle, or cycles once and stops.	Air valve is stuck or dirty.	Disassemble and clean air valve. See page 16. Use filtered air.
	Check valve ball (541) severely worn and wedged in seat (233) or manifold.	Replace ball and seat. See page 19.
	Check valve ball (541) is wedged into seat (233), due to overpressurization.	Follow Pressure Relief Procedure , page 10. Disassemble ball check assembly and inspect for damage, see page 19.
	Dispensing valve clogged.	Relieve pressure and clear valve.
	Leak detector has activated a shut-down solenoid	Investigate failure and reset leak detector
Pump operates erratically.	Clogged suction line.	Inspect; clear.
	Sticky or leaking balls (541).	Clean or replace. See page 19.
	Diaphragm ruptured.	Replace. See page 21.
	Restricted exhaust.	Remove restriction.
Air bubbles in fluid.	Suction line is loose.	Tighten.
	Diaphragm ruptured.	Replace. See page 21.
	Loose inlet manifold, damaged seal between manifold and seat, damaged gaskets.	Tighten manifold clamps or replace seats or gaskets. See page 19.

PROBLEM	CAUSE	SOLUTION
Leak in inlet or outlet sanitary fitting.	Loose sanitary clamp.	Tighten clamp.
	Damaged or worn gasket.	Replace gasket.
	Misalignment of inlet/outlet hose or pipe.	Use flexible hoses at pump inlet and outlet.
	Gasket does not seal.	Use a standard sanitary gasket of flexible material such as EPDM, Buna-N, fluoroelastomer, or silicon.
Fluid in exhaust air.	Diaphragm ruptured.	Replace. See page 21.
	Loose diaphragm plate.	Tighten or replace. See page 21.
Pump exhausts excessive air at stall.	Worn air valve block, plate, pilot block, u-cups, or pilot pin o-rings.	Repair or replace. See page 16.
	Worn shaft seals.	Replace. See page 21.
Pump leaks air externally.	Air valve cover is loose.	Tighten screws. See page 16.
	Air valve gasket or air cover gasket is damaged.	Inspect; replace. See page 16.
	Air cover clamps are loose	Tighten clamps.
Pump leaks fluid externally from ball check valves.	Loose manifolds, damaged seal between manifold and seat, damaged gaskets.	Tighten manifold clamps or replace seats or clamps (32). See page 19.
Chattering.	Check balls not seating properly/cleanly due to imbalance between fluid inlet and outlet line sizing. Noise is accentuated with light viscosity fluids.	Reduce size/diameter of inlet line relative to outlet line. Outlet line size should not exceed pump size.

Service

Repairing the Air Valve

Tool Required

- Torque wrench
- Torx (T20) screwdriver or 7 mm (9/32 in.) socket wrench
- Needle-nose pliers
- O-ring pick
- Lithium base grease

 Air Valve Repair Kit 255122 is available. Refer to **Parts** on page 31. Parts included in the kit are marked with ♦ symbol. Use all the parts in the kit for the best results.

Disassembly

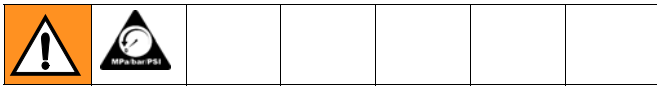

1. Relieve the pressure.
2. With a Torx (T20) screwdriver or 7 mm (9/32 in.) socket wrench, remove the six screws (103), air valve cover (102), and gasket (104). See FIG. 6.

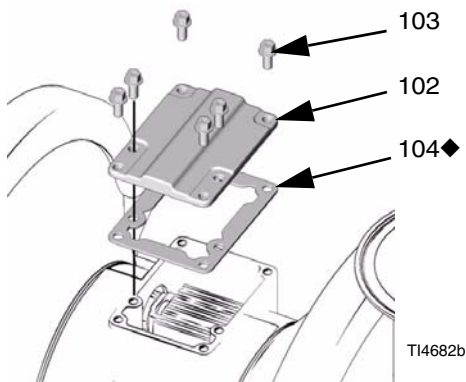

FIG. 6

3. Move the valve carriage (105) to the center position and pull it out of the cavity. Using a needle-nose pliers, pull the pilot block (116) straight up and out of the cavity. See FIG. 7.

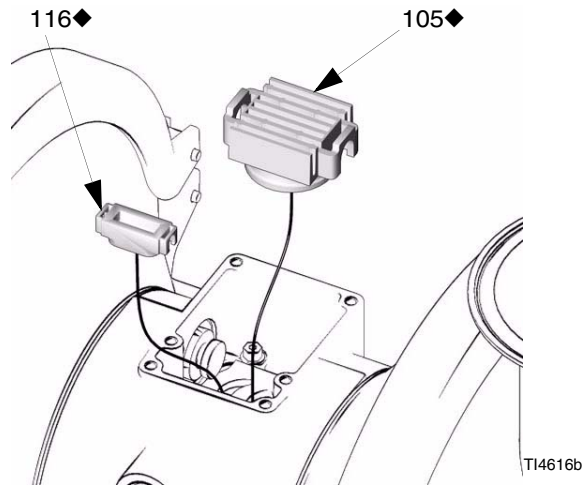

FIG. 7

4. Pull the two actuator pistons (111). Remove the u-cups (110) from the pistons. Pull the pilot pins (114). Remove the o-rings (115) from the pilot pins. See FIG. 8.

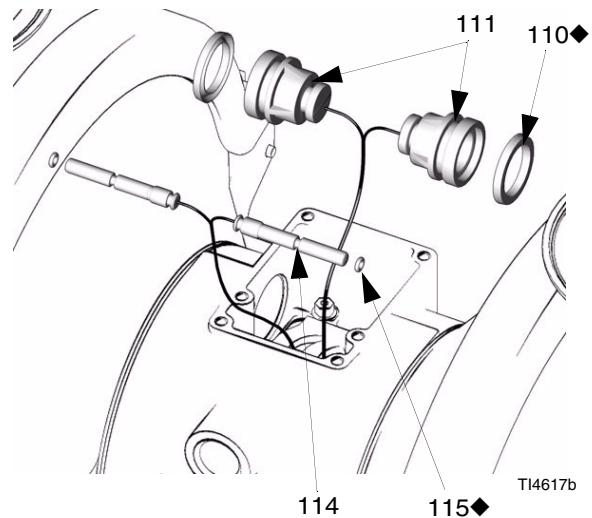

FIG. 8

5. Inspect the valve plate (108) in place. If damaged, use a Torx (T20) screwdriver or 7 mm (9/32 in.) socket wrench to remove the three screws (103). Remove the valve plate (108). See FIG. 9.

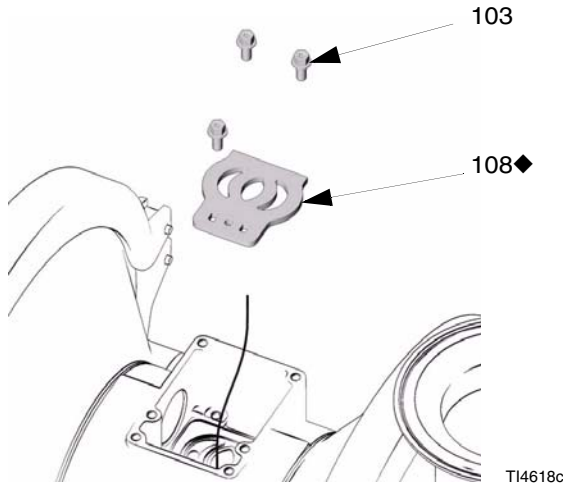

FIG. 9

6. Inspect the bearings (112, 117) in place. See **Parts** on page 31. The bearings are tapered and, if damaged, must be removed from the outside. This requires disassembly of the fluid section. See page 23.
7. Clean all parts and inspect for wear or damage. Replace as needed. Reassemble, page 17.

Reassembly

1. *If you replaced the bearings (112, 117),* reinstall as explained on page 24. Reassemble the fluid section.
2. Install the valve plate (108) in the cavity, seal down. Install the three screws (103), using a Torx (T20) screwdriver or 7 mm (9/32 in.) socket wrench. Tighten until the screws bottom out on the housing. See FIG. 9.

3. Install an o-ring (115) on each pilot pin (114). Grease the pins and o-rings. Insert the pins into the bearings, **narrow** end first. See FIG. 10.

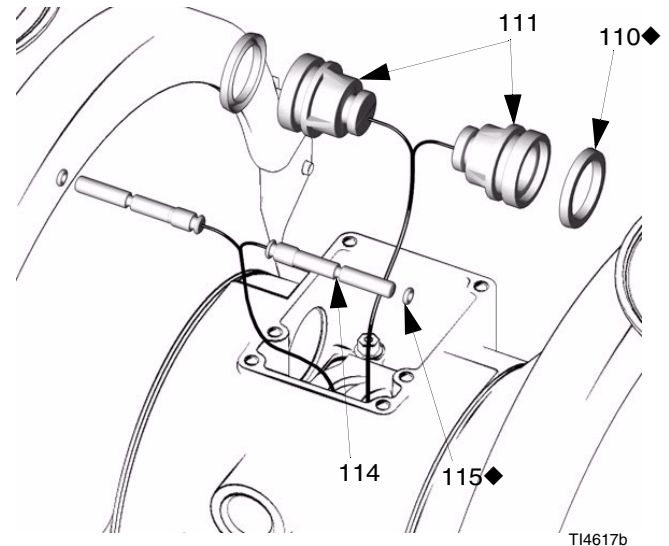

FIG. 10

4. Install u-cups (110) on each actuator piston (111), so the lips of the packings face the **narrow** end of the pistons. See FIG. 10.
5. Lubricate the u-cups (110) and actuator pistons (111). Insert the actuator pistons in the bearings, **wide** end first. Leave the narrow end of the pistons exposed. See FIG. 10.
6. Grease the lower face of the pilot block (116) and install so its tabs snap into the grooves on the ends of the pilot pins (114). See FIG. 11.
7. Grease the lower face of the valve carriage (105). See FIG. 11.

8. Install the valve carriage (105) so its tabs slip into the grooves on the narrow end of the actuator pistons (111). See FIG. 11.

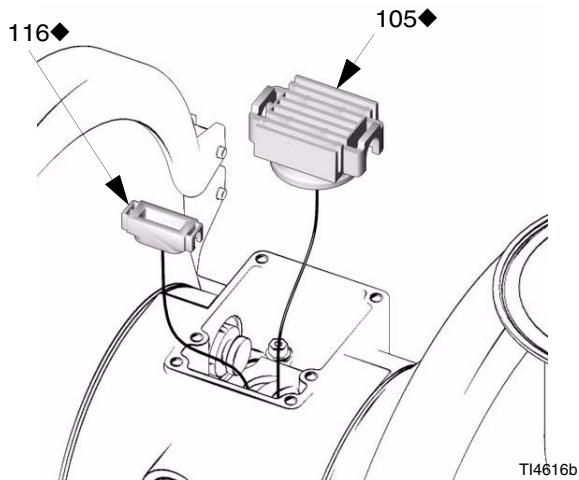

FIG. 11

9. Align the valve gasket (104) and cover (102) with the six holes in the center housing (101). Secure with six screws (103), using a Torx (T20) screwdriver or 7 mm (9/32 in.) socket wrench. Torque to 50-60 in-lb (5.7-6.8 N•m). See FIG. 12.

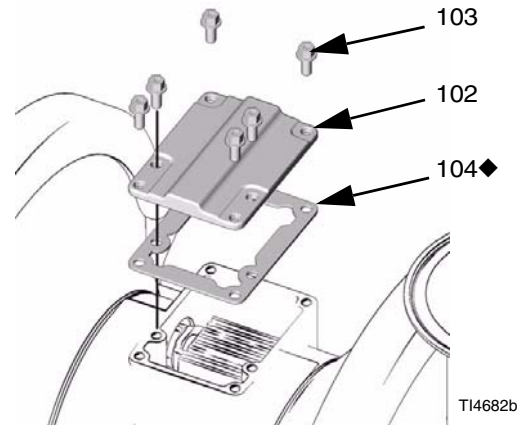

FIG. 12

Check Valve Repair

Disassembly



Reference numbers with an asterisk (*) are replacement parts. For a complete list of replacement parts see **Parts**, page 26.

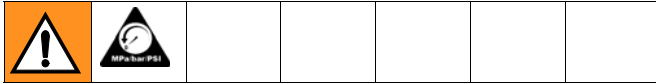

1. Relieve the pressure. Disconnect all hoses.
2. Remove the pump from its mounting. Drain.
3. From the outlet manifold, remove both upper clamps (132a).
4. Remove outlet manifold leaving elbows (128), gaskets (129), clamps (130), and tee (339) assembled.
5. *For 3A Ball Check pumps:* remove ball gasket (240). Remove middle clamp (132c) and ball stop housing (2XA). Remove middle gasket (240) and ball (541). Remove lower clamp (132b), seat (2XB), and gasket (240). Clean all parts and inspect for wear or damage. Replace parts as needed.

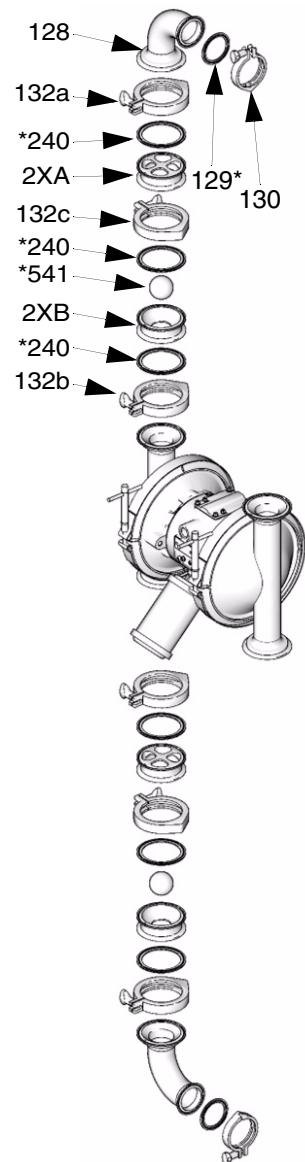

3A Ball Check Assembly

T18768a

FIG. 13

For Sanitary Ball Check pumps: remove ball gasket (242) and ball (541). Remove lower clamp (132b), seat (233), and gasket (240). Clean all parts and inspect for wear or damage. Replace parts as needed.

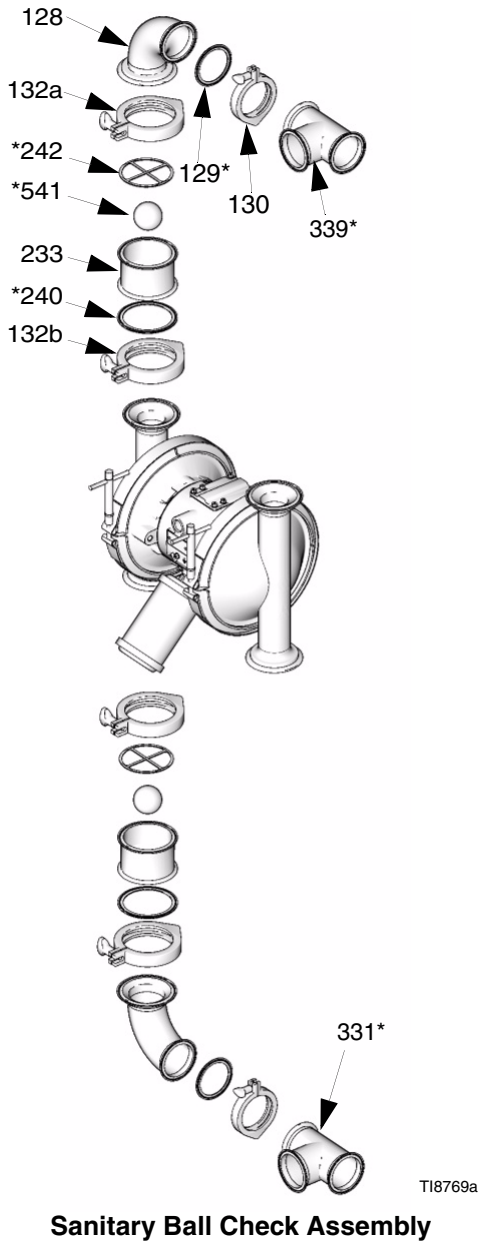
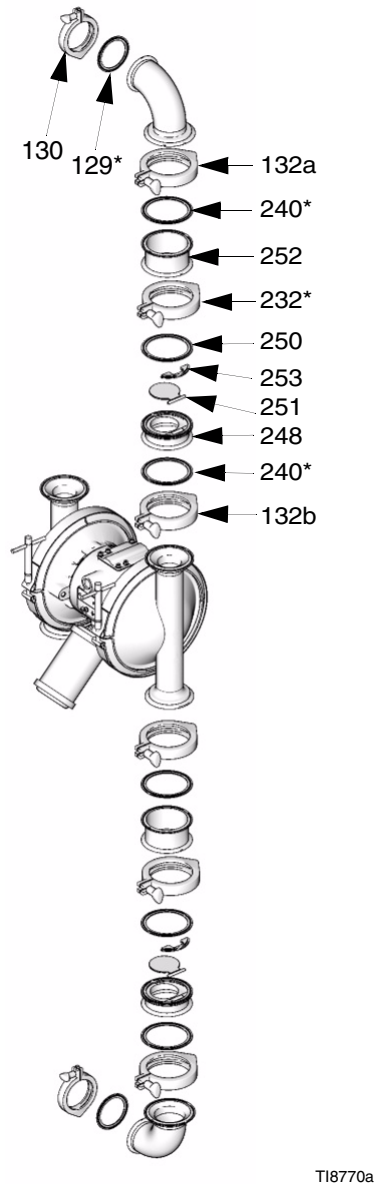

FIG. 14

For Flapper Check pumps: remove gasket (240). Remove middle clamp (232) and housing (252). Remove middle gasket (250), flapper retainer (253), and flapper valve (251). Remove lower clamp (132b), lower flapper housing (248), and gasket (240). Clean all parts and inspect for wear or damage. Replace parts as needed.



Flapper Check Assembly

FIG. 15

- Disassemble the outlet manifold. Remove clamps (130), tee (339), gasket (129), and elbow (128). Clean all parts and inspect for wear or damage. Replace parts as needed.

- Repeat for inlet manifold.

Reassembly

 Lubricate clamps, clamping surfaces, and gaskets with waterproof, sanitary lubricant.

- Reassemble inlet and outlet fluid manifolds in reverse order. See step 6. Tighten clamps handtight.
- Reassemble ball or flapper check assembly in reverse order. See step 5. Tighten clamps handtight.

 For flapper check, make sure flapper check (251) is placed properly in housing (248) groove and flapper retainer (253) is aligned with housing groove. Ensure that the flapper check moves freely.

Diaphragm Repair

Tools Required

- Torque wrench
- 5/8 in. wrench
- 19 mm open end wrench
- O-ring pick
- Lithium-base grease
- Spanner wrench

Disassembly



- Relieve the pressure.
- Remove the manifolds and disassemble the ball check valves as explained on page 19.
- Hold fluid covers in place and remove the clamps (135). Pull the fluid covers (234) off the pump

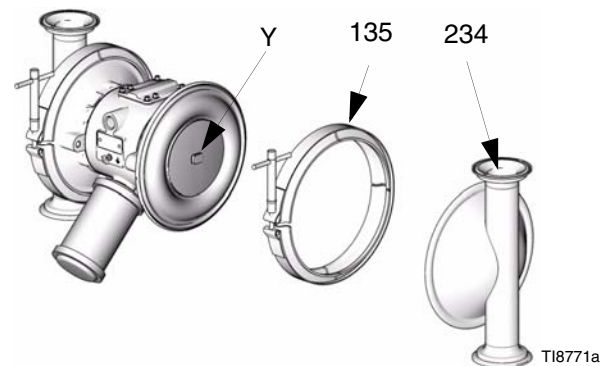

FIG. 16

- Non 3A approved diaphragms:* With both fluid covers removed, using two 5/8 in. wrenches hold the wrench flats (Y) on the plates of each diaphragm assembly and loosen. One diaphragm assembly will come free and the other will remain attached to the shaft.
3A approved diaphragms: Diaphragms are assembled handtight. To loosen, grip both diaphragms securely around the outer edge and rotate counter clockwise. One diaphragm assembly will come free and the other will remain attached to the shaft. Continue to step 6.
- Disassemble the free diaphragm assembly.
- Remove plate (444) with bolt (143) installed, diaphragm (446), backer (447) if present, and plate (445)

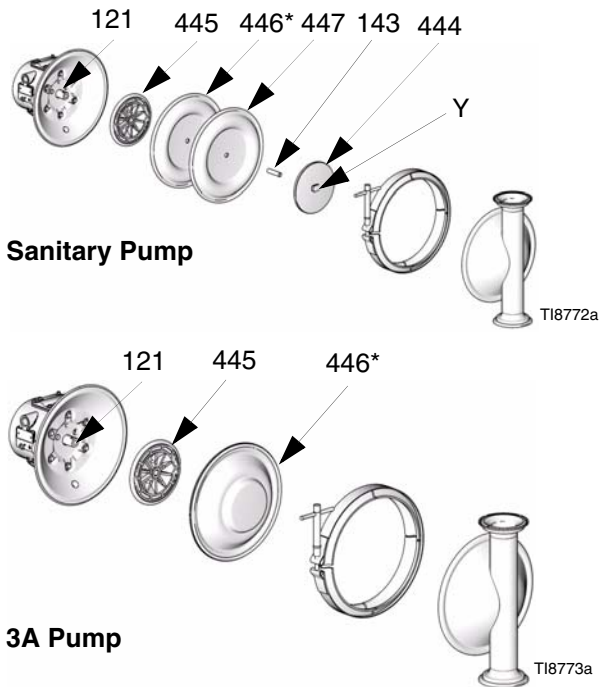

FIG. 17

7. Pull the other diaphragm assembly and the diaphragm shaft (121) out of the center housing (101). Hold the shaft flats with a 19 mm open end wrench, and remove the diaphragm assembly from the shaft. Disassemble the remaining diaphragm assembly.

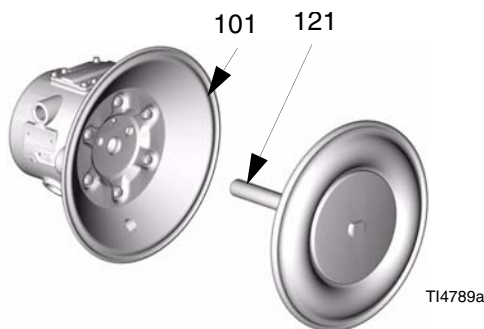

FIG. 18

8. Inspect the diaphragm shaft (121) for wear or scratches. If it is damaged, inspect the bearings (117) in place. If the bearings are damaged, refer to **Bearing and Air Gasket Removal** on page 23.
9. Reach into the center housing (101) with an o-ring pick and hook the u-cups (110), then pull them out of the housing. This can be done with the bearings (117) in place. See FIG. 22.
10. Clean all parts and inspect for wear or damage. Replace parts as needed.

Reassembly

1. Install the shaft u-cups (110) so the lips face **out** of the housing (101). Lubricate the u-cups. See reassembly of bearing and air gasket removal, page 24.
2. *Non 3A approved diaphragms:* Assemble diaphragm (446), backer (447) if present, and plate (445) onto plate (444) with screw (143). Rounded side of plate (445) should face diaphragm. Make sure the side marked AIR SIDE faces the center housing.
3A approved diaphragms: Assemble plate (445) onto diaphragm assembly (446). Round side of plate should face diaphragm.

Thread locker must be applied to screw (143) and to threads of 3A diaphragm assembly as shown in FIG. 19 for all diaphragm assemblies.

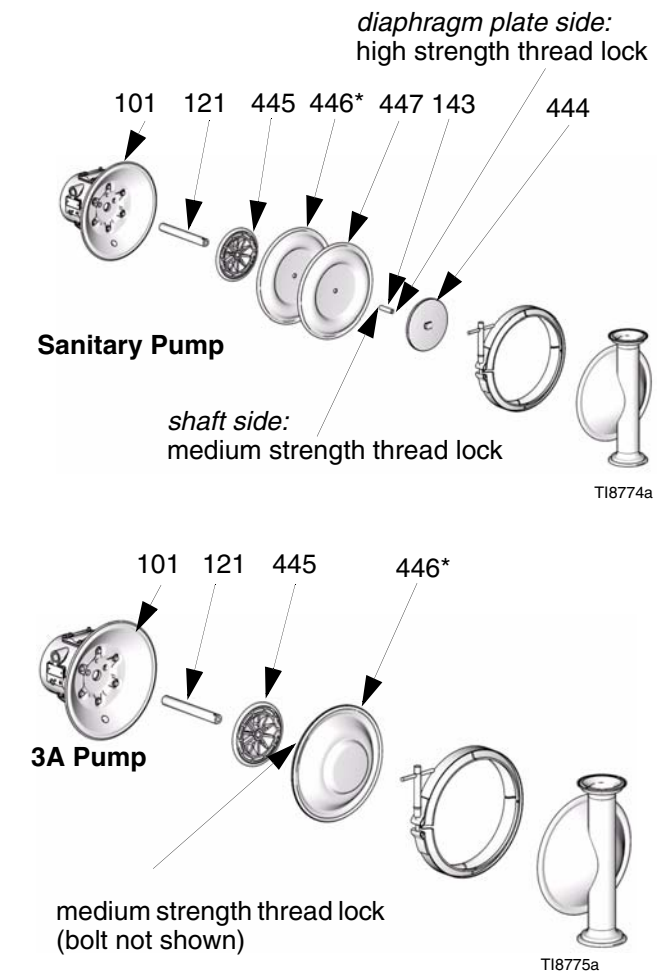



FIG. 19

3. Screw assembled diaphragm assembly into shaft (121) and hand tighten.

4. Grease the length of the diaphragm shaft (121), and slide it through the housing (101).
5. Assemble the other diaphragm assembly to the shaft as explained in step 2.
6. *Non 3A approved diaphragms:* Using a 5/8 in. wrench hold the wrench flats of one diaphragm assembly and torque the other diaphragm to 60-70 ft-lb (81-94 N•m).
3A approved diaphragms: Grip both diaphragms securely around the outer edge and handtighten.

 Waterproof, sanitary lubricant may be applied to the clamp (135) and clamping surface of the cover (234) to ease assembly.

7. Align the fluid covers (234) and the center housing. Secure the covers with the clamps (135) and hand tighten.

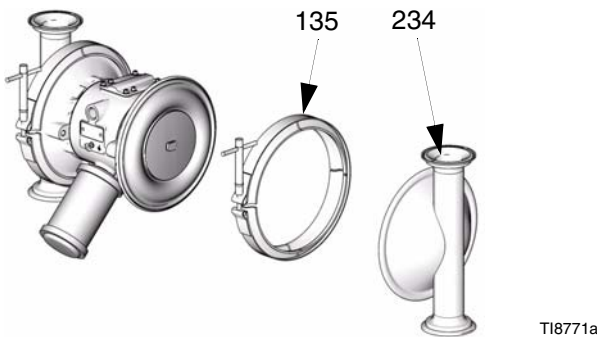

FIG. 20

8. Reassemble the ball check valves and manifolds as explained on page 19.

Bearing and Air Gasket Removal

Tools Required

- Torque wrench
- 10 mm socket wrench
- Bearing puller
- O-ring pick
- Press, or block and mallet

Disassembly

 Do not remove undamaged bearings.



1. Relieve the pressure.
2. Remove the manifolds and disassemble the ball check valves as explained on page 19.
3. Remove the fluid covers and diaphragm assemblies as explained on page 21.

 If you are removing only the diaphragm shaft bearing (117), skip step 4.

4. Disassemble the air valve as explained on page 16.
5. Using a 10 mm socket wrench, remove the screws (122) holding the air covers (120) to the center housing (101).

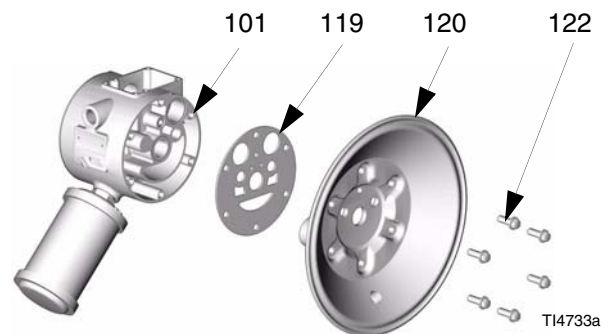

FIG. 21

6. Remove the air cover gaskets (119). Always replace the gaskets with new ones.
7. Use a bearing puller to remove the diaphragm shaft bearings (117), air valve bearings (112) or pilot pin bearings (113). Do not remove undamaged bearings

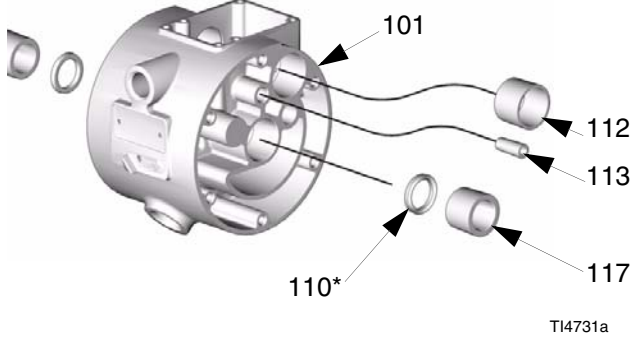



FIG. 22

8. If you removed the diaphragm shaft bearings (117) reach into the center housing (101) with an o-ring pick and hook the u-cups (110), then pull them out of the housing. Inspect the u-cups. See FIG. 22. Replace parts as needed.

Reassembly

 Adhesive must be applied to the outside surface of the bearing (112) and the inside surface of bore (Z) prior to assembly.

1. Install the shaft u-cups (110) so the lips face **out** of the housing.
2. Insert new bearings (112, 113, and 117) into the center housing (101), **tapered end first**. Using a press or a block and rubber mallet, press-fit the bearing so it is flush with the surface of the center housing.

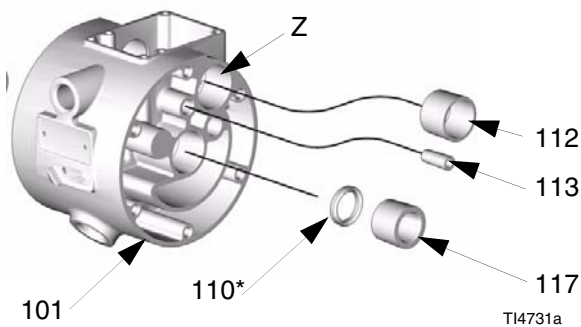

FIG. 23

3. Reassemble the air valve as explained on page 16.
4. Align the new air cover gasket (119) so the pilot pin (114) protruding from the center housing (101) fits through the proper hole in the gasket

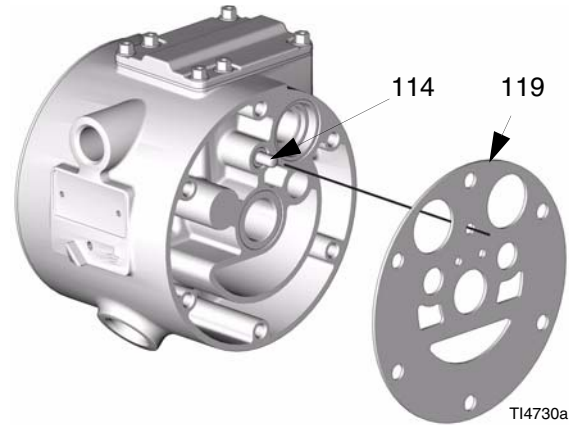

FIG. 24

5. Align the air cover (120) so the pilot pin (114) fits in the middle hole (M) of the three small holes near the center of the cover.

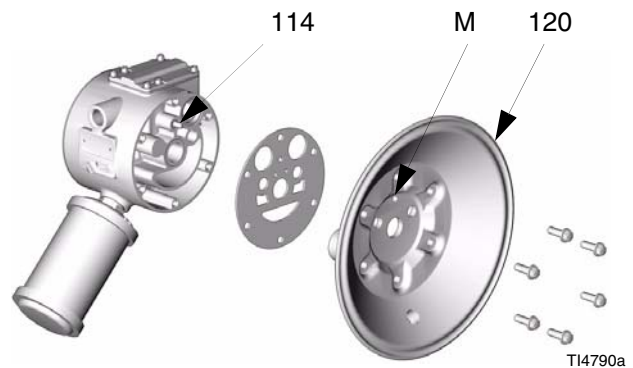

FIG. 25

6. Apply medium-strength (blue) Loctite® or equivalent to the threads of the screws (122). Install the screws (122), handtight. Using a 10 mm socket wrench, torque the screws oppositely and evenly to 130-150 in-lb (15-17 N•m). Install the diaphragm assemblies and fluid covers as explained on page 21.



FIG. 26

7. Reassemble the ball check valves and manifolds as explained on page 19.

Pump Matrix

3150 Stainless Steel Sanitary Pumps

Your Model No. is marked on the pump's serial plate. To determine the Model No. of your pump from the following matrix, select the six digits which describe your pump, working from left to right. The first digit is always **S**, designating Graco Sanitary diaphragm pumps. The remaining five digits define the pump configuration, size, and materials of construction. For example, a sanitary

ball check pump with a three inch inlet and outlet, Santoprene balls and diaphragms, a pump stand, and no leak detector is model **SB3661**. To order replacement parts, refer to the part lists on pages 26 - 31. *The digits in the matrix **do not** correspond to the reference numbers in the parts drawing and lists.*

Sanitary Pump	Pump Configuration	Inlet and Outlet (in.)	Diaphragm	Check Ball Material	Leak Detector, Pump Stand
S - (for all pumps)	A 3A Approved	1 1 1/2 x 1 1/2	A 3A Approved (EPDM)	A 3A Approved (PTFE)	A Leak Detector and Pump Stand
	B Ball Check	2 2 x 2	6 Santoprene®	6 Santoprene®	1 Pump Stand
	F Flapper Check	3 3 x 3	7 Buna-N	7 Buna-N	3 None
		4 4 x 4	8 fluoroelastomer	8 fluoroelastomer	
		5 3 x 2		F Flapper	
		P NONE			

1590 Stainless Steel Sanitary Pumps

The table below shows all available configurations for 1590 Stainless Steel Sanitary Pumps.

Model Number	Pump Configuration	Inlet and Outlet (in.)	Check Valve Style	Check Ball Material	Diaphragm Material
SABAAA	3A Approved	2 x 2	3A Ball Checks	3A PTFE	3A Approved EPDM
SBBAAA	Non-3A Approved No Leak Detector	2 x 2	3A Ball Checks	3A PTFE	3A Approved EPDM
SBBA11	Non-3A Approved No Leak Detector	2 x 2	3A Ball Checks	(3A) PTFE	PTFE
SBBA22	Non-3A Approved No Leak Detector	2 x 2	3A Ball Checks	Santoprene	Santoprene

Parts Drawing

3A Pump Shown

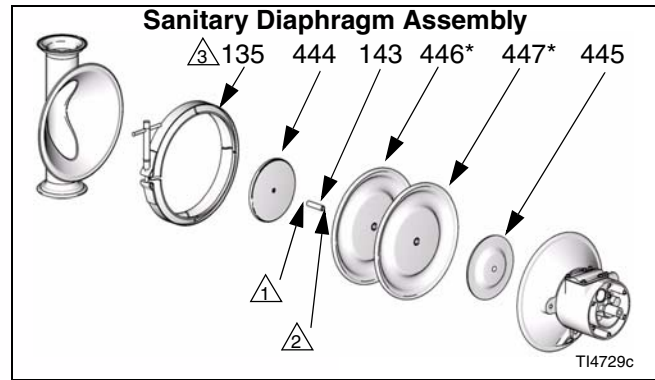
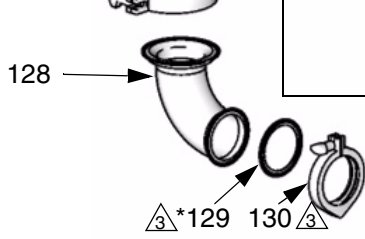
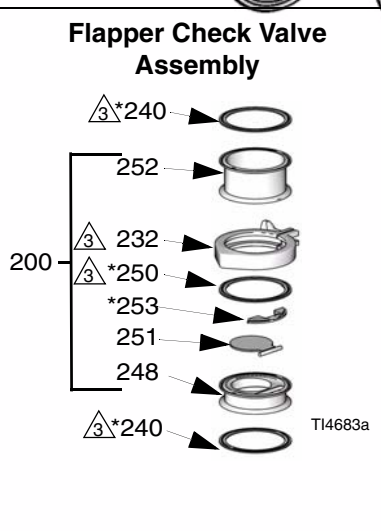
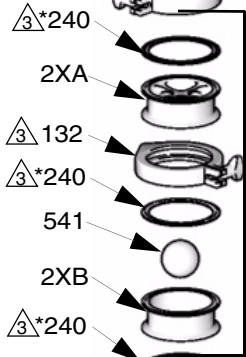
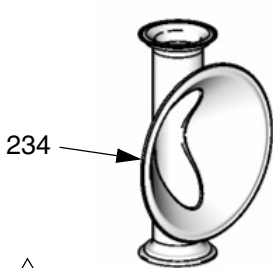
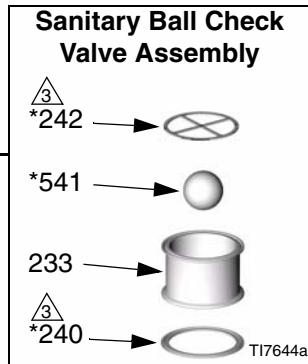
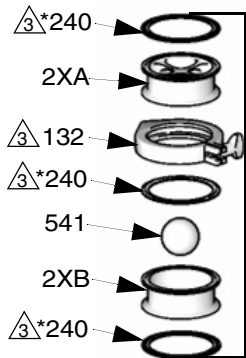
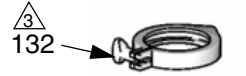
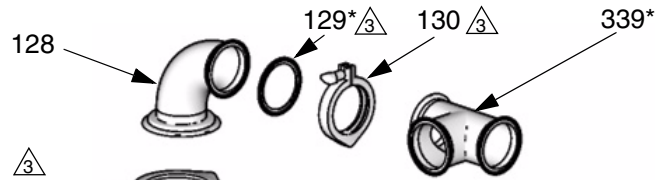

- ① Apply a high strength thread locker to diaphragm plate side of screw threads.
- ② Apply a medium strength thread locker to shaft side of screw threads.
- ③ Apply a waterproof sanitary lubricant to clamps, clamping surfaces, and gaskets.

TI7645c

Parts List

Pump Configuration Parts List

Digit	Ref. No.	Part No.	Description	Qty
Model 3150				
A 3A Approved Ball Check				
	132	510490	CLAMP, 4 in.	4
	2XB	15H406	SEAT	4
	234	249533	COVER, fluid	2
	240*	15H460	GASKET, 4 in., EPDM	12
	2XA	15H407	STOP, ball	4
B Ball Check				
	233	15D026	SEAT	4
	234	234530	COVER, fluid	2
	240*	15H460	GASKET, 4 in., EPDM	4
	242*	15D346	GASKET, ball stop	4
F Flapper Check				
	234	234530	COVER, fluid	2
	240*	15H460	GASKET, 4 in., EPDM	8
	200	249535	MODULE, flapper; includes items 232, 248, 250, 251, 252, 253	4
	232	510490	CLAMP, 4 in.	4
	248	15D079	HOUSING, lower flapper	4
	250*	15H460	GASKET, 4 in., EPDM	4
	251	15D091	VALVE, flapper, weldment	4
	252	15D090	HOUSING, upper flapper	4
	253*	15K693	RETAINER, flapper	4
Model 1590				
3A Approved Ball Check				
All	132	15D475	CLAMP, 3 in.	4
All	2XB	15H481	SEAT	4
All	234	249892	COVER, Fluid	2
All	240*	15H459	GASKET, 3 in., EPDM	12
All	2XA	15H482	STOP, Ball	4

* Indicates replacement parts.

Inlet and Outlet Parts List

Digit	Ref. No.	Part No.	Description	Qty
Model 3150				
1 1 1/2 x 1 1/2 in. tee				
	331*	234536	TEE, inlet	1
	339*	234536	TEE, outlet	1
2 2 x 2 in. tee				
	331*	234534	TEE, inlet	1
	339*	234534	TEE, outlet	1
3 3 x 3 in. tee				
	331*	234532	TEE, inlet	1
	339*	234532	TEE, outlet	1
4 4 x 4 in. tee				
	331*	234535	TEE, inlet	1
	339*	234535	TEE, outlet	1
5 3 x 2 in. tee				
	331*	234532	TEE, inlet	1
	339*	234534	TEE, outlet	1
Model 1590				
2 x 2 in. Tee				
All	331*	249893	TEE, Inlet	1
All	339*	249893	TEE, Outlet	1

* Indicates replacement parts.

Diaphragm Material Parts List

Digit	Ref.	Part	Description	Qty
Model 3150				
A	253224 3A Approved, EPDM, Overmolded; includes 110 and 446			
	110	112181	U-CUP	2
	446*†		DIAPHRAGM ASSY	2
	445	189298	PLATE, diaphragm (air side)	2
6	253225 Santoprene; includes 110, 446			
	110	112181	U-CUP	2
	446*†		DIAPHRAGM	2
	143	15D021	BOLT	2
	444	15D018	PLATE, diaphragm	2
	445	189298	PLATE, diaphragm	2
7	253223 Buna-N; includes 110, 446			
	110	112181	U-CUP	2
	446*†		DIAPHRAGM	2
	143	15D021	BOLT	2
	444	15D018	PLATE, diaphragm	2
	445	189298	PLATE, diaphragm	2
8	253222 fluoroelastomer; includes 110, 446			
	110	112181	U-CUP	2
	446*†		DIAPHRAGM	2
	143	15D021	BOLT	2
	444	15D018	PLATE, diaphragm	2
	445	189298	PLATE, diaphragm	2

Model	Ref.	Part	Description	Qty
Model 1590				
255058 3A Approved, EPDM, Overmolded; includes 110 and 446				
SABAAA SBBAAA	110	112181	U-CUP	2
	446*†		DIAPHRAGM ASSEMBLY	2
	445	15K448	PLATE, Diaphragm (air side)	
255059 Santoprene; includes 110 and 446				
SBBAA2	110	112181	U-CUP	2
	446*†		DIAPHRAGM	2
	143	15D021	BOLT	2
	444	15K288	PLATE, Diaphragm (fluid side)	2
	445	15K448	PLATE, Diaphragm (air side)	2
255060 PTFE; includes 110 and 446 and 447				
SBBAA1	110	112181	U-CUP	2
	446*†		DIAPHRAGM	2
	447*†		BACKER	2
	143	15D021	BOLT	2
	444	15K288	PLATE, Diaphragm (fluid side)	2
	445	15K448	PLATE, Diaphragm (air side)	2



All diaphragm modules above include 2 u-cups (110) to replace seals around shaft (121). See page 30.

- * Indicates replacement parts.
- † Indicates a recommended spare part.

Check Ball Material Parts List

Digit	Ref.	Part	Description	Qty
Model 3150				
A	3A Approved, PTFE			
	541*†	112359	BALL	4
F	Flapper check			
		NONE		
6	Santoprene			
	541*†	112361	BALL	4
7	BUNA-N			
	541*†	15B492	BALL	4
8	fluoroelastomer			
	541*†	15B491	BALL	4
Model 1590				
	3A Approved PTFE			
SABAAA SBBAAA SBBA11	541*†	112419	BALL	4
	Santoprene			
SBBA22	541*†	112421	BALL	4

* Indicates replacement parts.

† Indicates a recommended spare part.

Parts Drawing

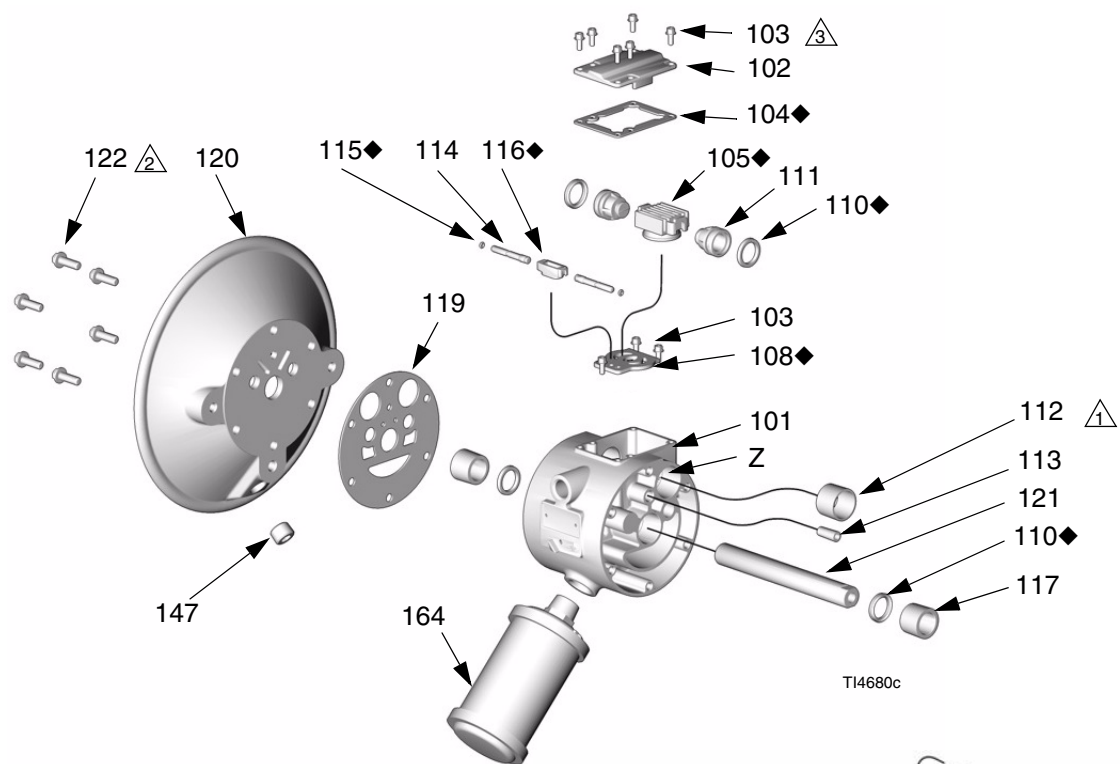

- △ Apply medium strength adhesive to outside surface of piston bearing and inside surface of center housing bore.
- △ Apply a medium strength thread locker to screw threads and torque to 130-150 in-lbs (14.6-16.9 N•m).
- △ Torque to 50-60 in-lb (5.7-6.8 N•m).

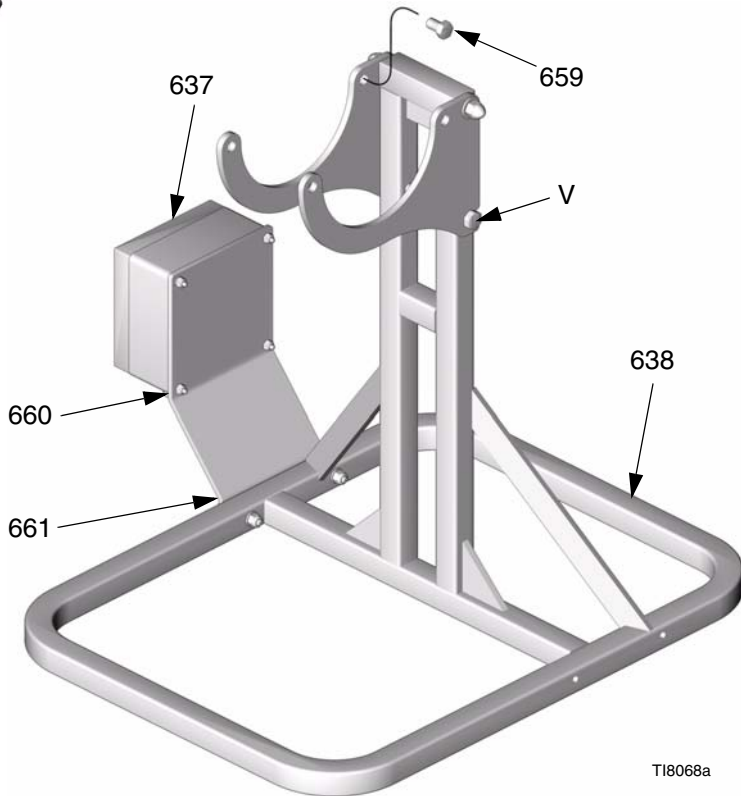

Parts List

Air Section Parts

Ref.	Part	Description	Qty.
101	15K010	HOUSING, center	1
102	15K697	HOUSING, cover	1
103	116344	SCREW, mach, torx	10
104◆	188618	GASKET, cover	1
105◆	248904	CARRIAGE, manifold assy	1
108◆	15H178	VALVE, plate	1
110◆	112181	U-CUP, packing	4
111	188612	PISTON, actuator	2
112	188613	BEARING, piston	2
113	188611	BEARING, pin	2
114	188610	PIN, push	2
115◆	157628	O-RING	2
116◆	188614	BLOCK, pilot	1
117	188609	BEARING, shaft	2
119	188603	GASKET air cover	2
120	15D016	COVER, machined air, 3150	2
	15G694	COVER, machined air, 1590	2
121	189245	SHAFT	1
122	112178	SCREW	12
147	103778	PLUG	2
162▲	188621	TAG, warning	1
164	15G332	MUFFLER	1

◆ Parts included in Air Valve Repair Kit 255122 (purchase separately).

▲ Replacement Danger and Warning labels, tags, and cards are available at no cost.

Fluid Section Parts

Ref.	Part	Description	Qty.
Model 3150			
128	234531	ELBOW	4
129	15H459	GASKET, sanitary, EPDM, 3 in.	4
130	15D475	CLAMP, sanitary, 3 in.	4
132	510490	CLAMP, sanitary, 4 in.	8
135	15G323	CLAMP, sanitary, diaphragm	2
Model 1590			
128	249894	ELBOW	4
129	15H598	GASKET, sanitary, EPDM, 2 in.	4
130	500984	CLAMP, sanitary, 2 in.	4
132	15D475	CLAMP, sanitary, 3 in.	8
135	15H341	CLAMP, sanitary, dia-phragm	2

Leak Detector and Pump Stand Parts List

Digit	Ref.	Part	Description	Qty
A	3A Approved, Leak Detector and Pump Stand 3150 and 1590 SABAAA			
	637	15D990	LEAK DETECTOR	1
	638	15F694	FRAME	1
	659	15D008	BOLT, sst	4
	660	15H971	GASKET, upper	1
	661	15H972	GASKET, lower	1
1	Pump Stand Only 3150 and 1590 SBBAAA, SBBA11, SBBA22			
	638	15F694	FRAME	1
	659	15D008	BOLT, sst	4
3	Bare Pump			
			none	

* Indicates replacement parts.

† Indicates a recommended spare part.

Accessories

15D990 Leak Detector

Sensor and control package that monitors the diaphragm condition. In case of diaphragm failure, the control will provide an audible alarm and relay contacts for remote alarms or solenoids. See Leak Detector manual 311200.

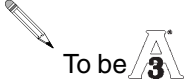

To be **3A** approved, a leak detection system must be used on the pump. Any pump with a leak detector installed is NOT Atex approved.

3150 Conversion Kits

15H461 3A Approved Ball Check Conversion Kit

Converts flapper check valve to 3A ball check valve. Includes four seats and four ball stops. Balls need to be ordered separately.

Part No.	Description	Qty.
15B406	SEAT, ball	4
15H460	GASKET, 4 in.	12
510490	CLAMP, 4 in.	4
15H407	STOP, ball	4

15D989 Flapper Valve Conversion Kit

Converts ball check valve to flapper check valve. Includes four flapper assemblies. See **Flapper Valve Assembly**, page 26.

Part No.	Description	Qty.
513548	GASKET, 4 in.	8
249535	MODULE, flapper	4

15E285 Sanitary Ball Check Conversion Kit

Converts flapper check valve to sanitary ball check valve. Includes four seats and four ball stops. Balls need to be ordered separately.

Part No.	Description	Qty.
15D026	SEAT, ball	4
15D346	GASKET, ball stop	4

Model 1590 Dimensional Drawing

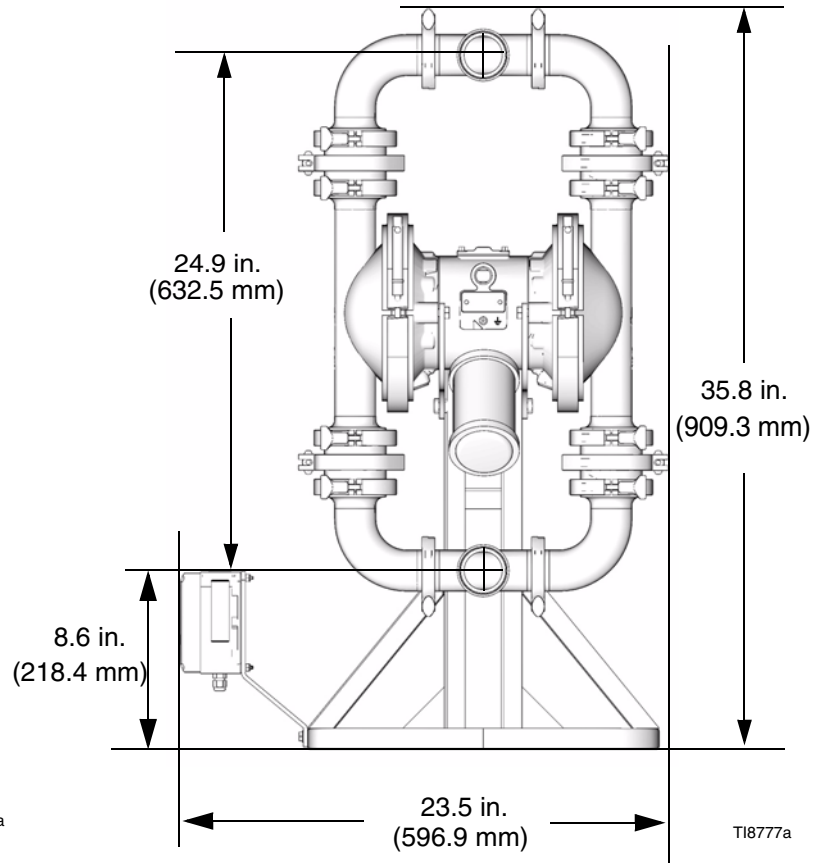
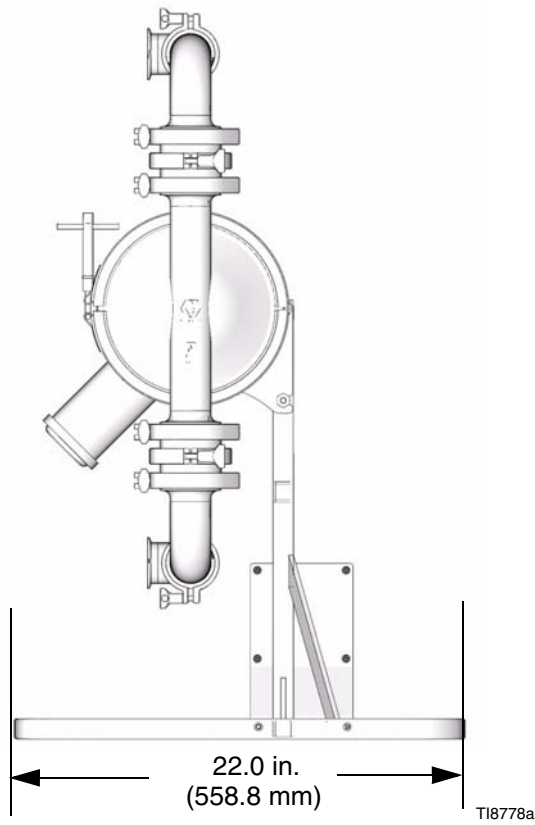

Model 1590

Technical Data

Maximum fluid working pressure	120 psi (0.8 MPa, 8 bar)
Air pressure operating range	20-120 psi (0.14-0.8 MPa, 1.4-8 bar)
Maximum air consumption	125 scfm
Air consumption at 70 psi air inlet pressure/60 gpm.	50 scfm (see chart)
Maximum free-flow delivery	100 gpm (378.5 l/min)
Maximum pump speed	200 cpm
* Gallons (Liters) per cycle	0.5 (1.96)
Maximum suction lift.	28 ft (8.5 m) wet, 15 ft (4.57 m) dry
Maximum size pumpable solids	5/8 in. (15.9 mm)

** Maximum Noise Level at 100 psi, full flow	90 dBa
** Sound Power Level.	103 dBa
** Noise Level at 70 psi and 50 cpm.	85 dBa

Maximum fluid operating temperature is based on the following maximum diaphragm, ball, and o-ring temperature ratings.	PTFE 220°F (104.4°C) Santoprene® 180°F (82.2°C) 3A Approved EPDM 275°F (135°C)
--	--

Air inlet size 0.5 in. npt(f)

Wetted parts

***All fluid contact materials are FDA-compliant and meet the United States Code of Federal Regulations (CFR) Title 21, Section 177.

All fluid contact materials are FDA-compliant.

Wetted materials on all models	316 SST, 3A Approved EPDM, PTFE,
Wetted material depending on model.	Santoprene®, 3A Approved EPDM, PTFE

CAUTION:

Santoprene® may be used only with non-fatty, non-oily foods or alcohols up to 15%.

Non-wetted external parts	300 series stainless steel, polyester (labels), LDPE foam (gasket)
-------------------------------------	--

Weight 97 lb (44 kg)

Santoprene® is a registered trademark of the Monsanto Co.

Loctite® is a registered trademark of the Loctite Corporation.

* *Displacement per cycle may vary based on suction condition, discharge head, air pressure, and fluid type.*

** *Noise levels measured with the pump mounted on the stand. Sound power measured per ISO Standard 9614-1.*

*** *The pump user must verify that the construction materials meet their specific application requirements.*

Model 1590 Performance Chart

Test Conditions: Pump tested in water with inlet submerged

To find Fluid Outlet Pressure

(psi/MPa/bar) at a specific fluid flow (gpm/lpm) and operating air pressure (psi/MPa/bar):

1. Locate fluid flow rate along bottom of chart.
2. Follow vertical line up to intersection with selected fluid outlet pressure curve.
3. Follow left to scale to read fluid outlet pressure.

To find Pump Air Pressure

(scfm or m³/min) at a specific fluid flow (gpm/lpm) and operating air pressure (psi/MPa/bar):

1. Locate fluid flow rate along bottom of chart.
2. Read vertical line up to intersection with selected air consumption curve.
3. Follow left to scale to read fluid outlet pressure.

1590 3A Performance Chart

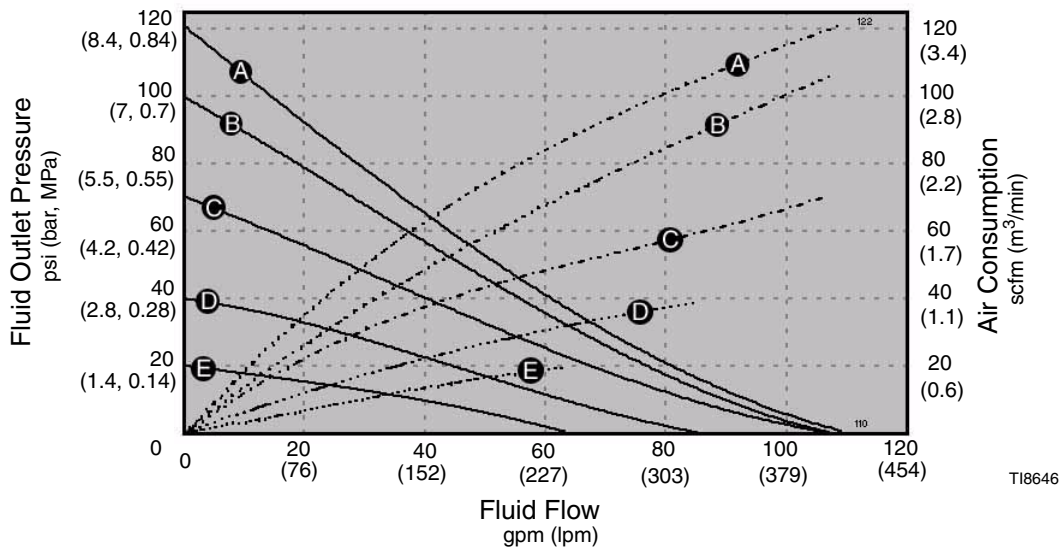

AIR PRESSURES	LEGEND
(A) = @ 120 psi (8.4 bar, 0.84 MPa)	Air Consumption - - - - -
(B) = @ 100 psi (7.0 bar, 0.7 MPa)	Fluid Flow - - - - -
(C) = @ 70 psi (4.8 bar, 0.5 MPa)	
(D) = @ 40 psi (2.8 bar, 0.3 MPa)	
(E) = @ 20 psi (1.4 bar, 0.14 MPa)	

T18647

Model 3150

Dimensional Drawing

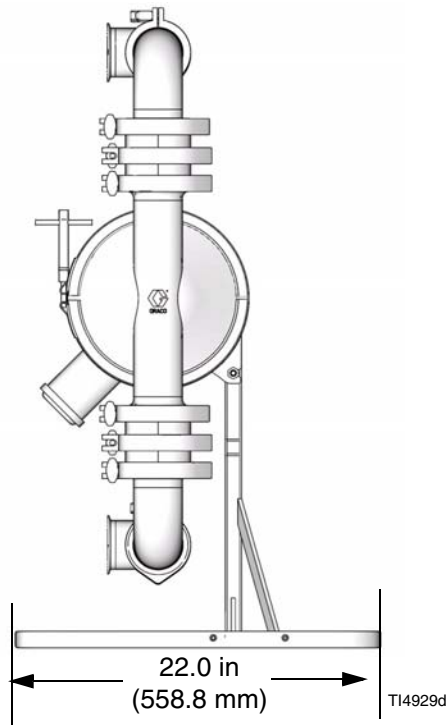

3A Ball Check Valve Pumps

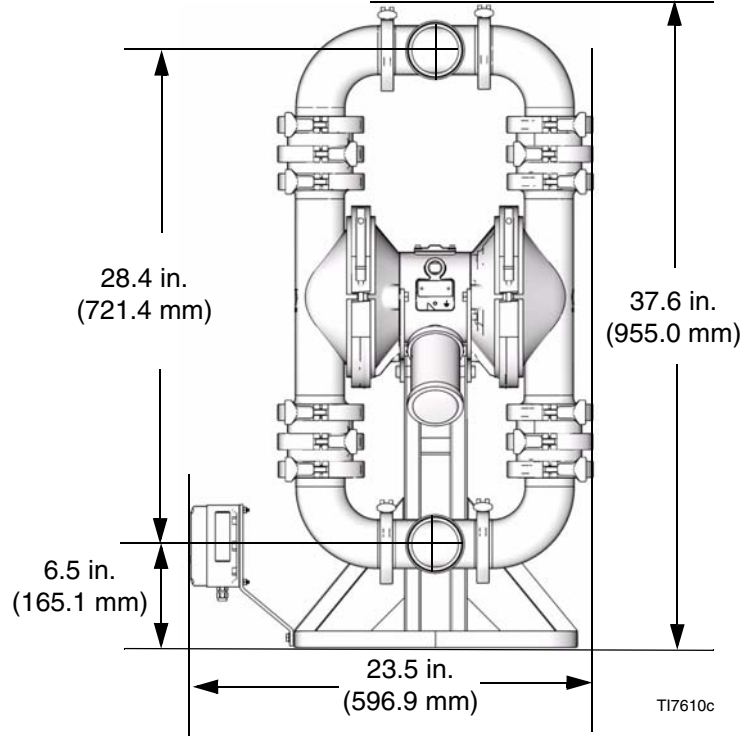

Sanitary Ball Check Valve Pumps

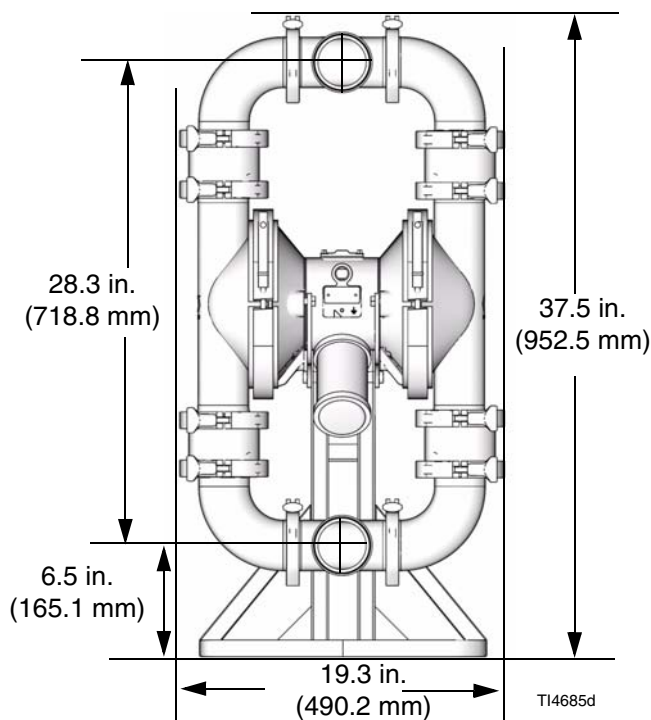

Flapper Check Valve Pumps

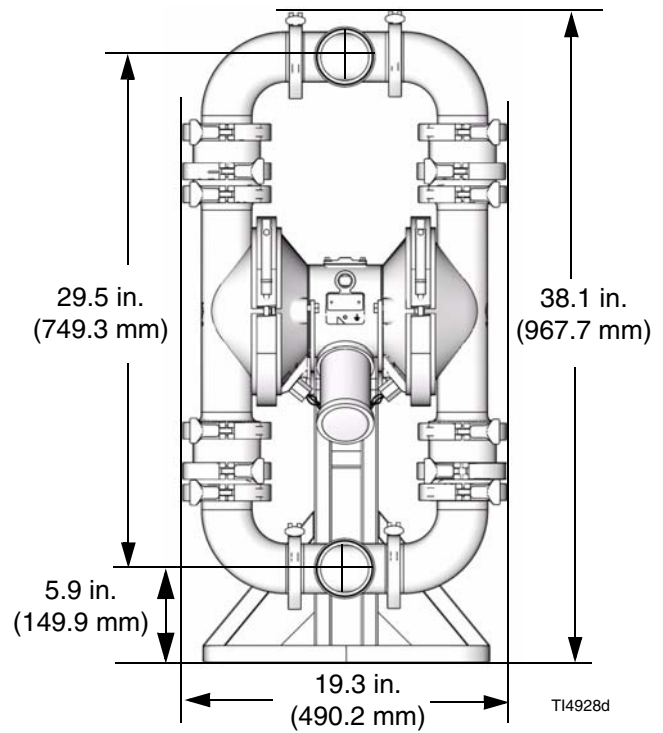

Model 3150

Technical Data

Maximum fluid working pressure	120 psi (0.8 MPa, 8 bar)
Air pressure operating range	20-120 psi (0.14-0.8 MPa, 1.4-8 bar)
Maximum air consumption	175 scfm
Air consumption at 70 psi air inlet pressure/60 gpm.	50 scfm (see chart)
Maximum free-flow delivery	150 gpm (570 l/min)
Maximum pump speed	145 cpm
* Gallons (Liters) per cycle	1.03 (3.90)
Maximum suction lift	Flapper 10 ft (3.5 m) wet, 5 ft (1.75 m) dry Ball 18 ft (5.5 m) wet, 9 ft (2.75 m) dry
Maximum size pumpable solids	Flapper 2.5 in. (63.5 mm) Ball 1.0 in. (25.4 mm)
** Maximum Noise Level at 100 psi, full flow 90 dBa	
** Sound Power Level 103 dBa	
** Noise Level at 70 psi and 50 cpm. 85 dBa	
Maximum fluid operating temperature is based on the following maximum diaphragm, ball, and seat temperature ratings.	PTFE 220°F (104.4°C) Santoprene® 180°F (82.2°C) Buna-N 180°F (82.2°C) fluoroelastomer 250°F (121.1°C) 3A Approved EPDM 275°F (135°C)

Air inlet size 0.5 in. npt(f)

Wetted parts

***All fluid contact materials are FDA-compliant and meet the United States Code of Federal Regulations (CFR) Title 21, Section 177.

Wetted materials on all models.	316 SST, 3A Approved EPDM
Wetted material depending on model.	316 SST, Santoprene®, Buna-N (Nitrile), fluoroelastomer, 3A Approved EPDM, PTFE

CAUTION:

Santoprene® may be used only with non-fatty, non-oily foods or alcohols up to 15%.

Non-wetted external parts. 300 series stainless steel, polyester (labels), LDPE foam (gasket)

Weight 145 lb (66 kg)

Santoprene® is a registered trademark of the Monsanto Co.

Loctite® is a registered trademark of the Loctite Corporation.

- * Displacement per cycle may vary based on suction condition, discharge head, air pressure, and fluid type.
- ** Noise levels measured with the pump mounted on the stand. Sound power measured per ISO Standard 9614-1.
- *** The pump user must verify that the construction materials meet their specific application requirements.

Model 3150 Performance Chart

Test Conditions: Pump tested in water with inlet submerged

To find Fluid Outlet Pressure

(psi/MPa/bar) at a specific fluid flow (gpm/lpm) and operating air pressure (psi/MPa/bar):

1. Locate fluid flow rate along bottom of chart.
2. Follow vertical line up to intersection with selected fluid outlet pressure curve.
3. Follow left to scale to read fluid outlet pressure.

To find Pump Air Pressure

(scfm or m³/min) at a specific fluid flow (gpm/lpm) and operating air pressure (psi/MPa/bar):

1. Locate fluid flow rate along bottom of chart.
2. Read vertical line up to intersection with selected air consumption curve.
3. Follow left to scale to read fluid outlet pressure.

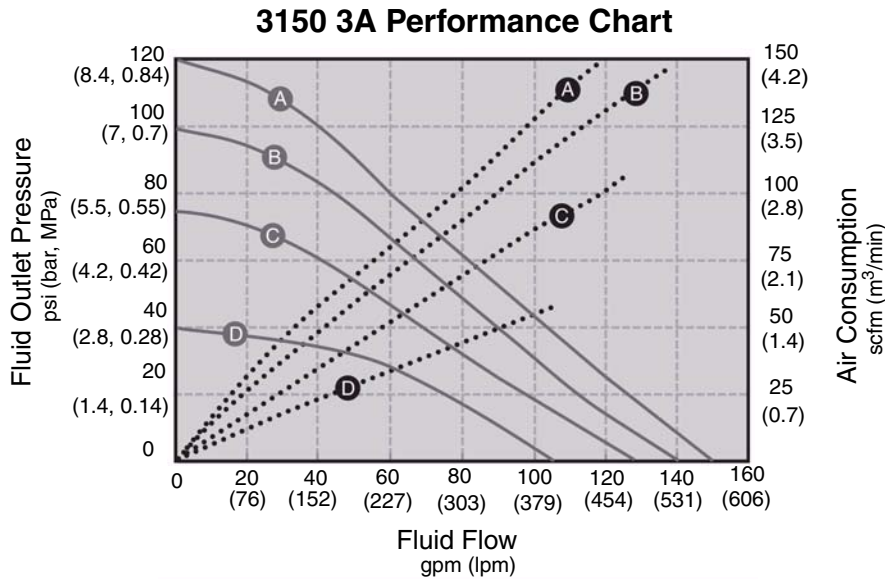

T18644a

AIR PRESSURES	LEGEND
(A) = @ 120 psi (8.4 bar, 0.84 MPa)	Air Consumption (dotted line)
(B) = @ 100 psi (7.0 bar, 0.7 MPa)	Fluid Flow _____ (solid line)
(C) = @ 70 psi (4.8 bar, 0.5 MPa)	
(D) = @ 40 psi (2.8 bar, 0.3 MPa)	

T18645a



A series of horizontal lines for writing, starting from the top line and extending down to the bottom line.

Graco Warranties

Graco Standard Pump Warranty

Graco warrants all equipment manufactured by Graco and bearing its name to be free from defects in material and workmanship on the date of sale to the original purchaser for use. With the exception of any special, extended, or limited warranty published by Graco, Graco will, for a period of five years from the date of sale, repair or replace any part of the equipment determined by Graco to be defective. This warranty applies only when the equipment is installed, operated and maintained in accordance with Graco's written recommendations.

This warranty does not cover, and Graco shall not be liable for general wear and tear, or any malfunction, damage or wear caused by faulty installation, misapplication, abrasion, corrosion, inadequate or improper maintenance, negligence, accident, tampering, or substitution of non-Graco component parts. Nor shall Graco be liable for malfunction, damage or wear caused by the incompatibility of Graco equipment with structures, accessories, equipment or materials not supplied by Graco, or the improper design, manufacture, installation, operation or maintenance of structures, accessories, equipment or materials not supplied by Graco.

This warranty is conditioned upon the prepaid return of the equipment claimed to be defective to an authorized Graco distributor for verification of the claimed defect. If the claimed defect is verified, Graco will repair or replace free of charge any defective parts. The equipment will be returned to the original purchaser transportation prepaid. If inspection of the equipment does not disclose any defect in material or workmanship, repairs will be made at a reasonable charge, which charges may include the costs of parts, labor, and transportation.

THIS WARRANTY IS EXCLUSIVE, AND IS IN LIEU OF ANY OTHER WARRANTIES, EXPRESS OR IMPLIED, INCLUDING BUT NOT LIMITED TO WARRANTY OF MERCHANTABILITY OR WARRANTY OF FITNESS FOR A PARTICULAR PURPOSE.

Graco's sole obligation and the buyer's sole remedy for any breach of warranty shall be as set forth above. The buyer agrees that no other remedy (including, but not limited to, incidental or consequential damages for lost profits, lost sales, injury to person or property, or any other incidental or consequential loss) shall be available. Any action for breach of warranty must be brought within six years of the date of sale.

Graco makes no warranty, and disclaims all implied warranties of merchantability and fitness for a particular purpose in connection with accessories, equipment, materials or components sold but not manufactured by Graco. These items sold, but not manufactured by Graco (such as electric motors, switches, hose, etc.), are subject to the warranty, if any, of their manufacturer. Graco will provide purchaser with reasonable assistance in making any claim for breach of these warranties.

In no event will Graco be liable for indirect, incidental, special or consequential damages resulting from Graco supplying equipment hereunder, or the furnishing, performance, or use of any products or other goods sold hereto, whether due to a breach of contract, breach of warranty, the negligence of Graco, or otherwise.

FOR GRACO CANADA CUSTOMERS

The parties acknowledge that they have required that the present document, as well as all documents, notices and legal proceedings entered into, given or instituted pursuant hereto or relating directly or indirectly hereto, be drawn up in English. Les parties reconnaissent avoir convenu que la rédaction du présente document sera en Anglais, ainsi que tous documents, avis et procédures judiciaires exécutés, donnés ou intentés, à la suite de ou en rapport, directement ou indirectement, avec les procédures concernées.

Extended Product Warranty

Graco warrants all 205, 307, 515, 716, 1040, 1590, 2150, 3150, and 3275 air valve center sections to be free from defects in material and workmanship for a period of fifteen years from date installed in service by the original purchaser. Normal wear of items such as packings or seals are not considered to be defects in material and workmanship.

Five years	Graco will provide parts and labor.
Six to Fifteen years	Graco will replace defective parts only.

Graco Information

TO PLACE AN ORDER, contact your Graco distributor, or call this number to identify the distributor closest to you.

1-800-328-0211 Toll Free

612-623-6921

612-378-3505 Fax

*All written and visual data contained in this document reflects the latest product information available at the time of publication.
Graco reserves the right to make changes at any time without notice.*

This manual contains English. MM 310622

Graco Headquarters: Minneapolis
International Offices: Belgium, China, Japan, Korea

GRACO INC. P.O. BOX 1441 MINNEAPOLIS, MN 55440-1441

www.graco.com

5/2004, Revised 4/2007

Free Manuals Download Website

<http://myh66.com>

<http://usermanuals.us>

<http://www.somanuals.com>

<http://www.4manuals.cc>

<http://www.manual-lib.com>

<http://www.404manual.com>

<http://www.luxmanual.com>

<http://aubethermostatmanual.com>

Golf course search by state

<http://golfingnear.com>

Email search by domain

<http://emailbydomain.com>

Auto manuals search

<http://auto.somanuals.com>

TV manuals search

<http://tv.somanuals.com>