

INSTALLATION INSTRUCTIONS Uromat 3000

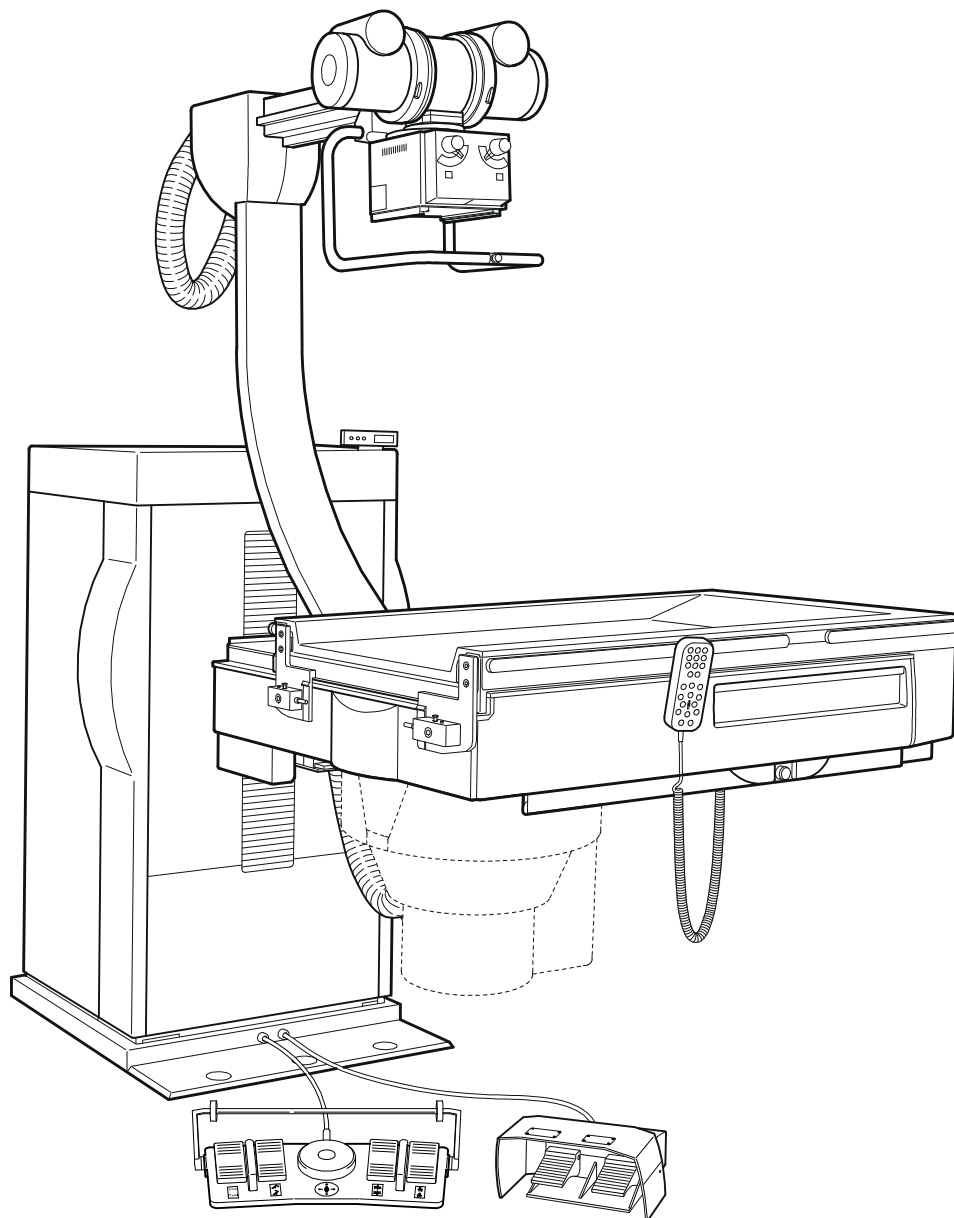

English Version

06/00

- 1 of 90 -

0116 7201

Rev. 00 © 2000 Hans Pausch Röntgengerätebau Graf-Zeppelin-Str. 1 D-91056 Erlangen ALL RIGHTS RESERVED Ru

CONTENTS

Page

1. Technical Data

1.1	General Safety Information	4
1.2	Component Weights	4
1.3	Component Dimensions	4
1.4	Packaging Dimensions and Weights	4
1.5	Component Designations	5
1.6	Dimensional Drawing	6
1.7	Cable Lengths of the High Voltage, Collimator, Adjustable Bucky and Image Intensifier Cables	10
1.8	Power Line Connection Data	11
1.9	Required Special Tools	11
1.10	Required Test Equipment	11
1.11	Environmental Conditions	11
1.12	Operating Conditions	11
1.13	Circuit Diagram Overview	12
1.14	Component Designations for the Circuit Diagram	27
1.15	Function Description of the Controller	31

2. Installation

2.1	Preparations for Installation	35
2.2	Unpacking the Unit Parts	35
2.3	Taking the Unit Off the Pallet	36
2.4	Installing the Unit	37
2.5	Aligning the Unit	38
2.6	Temporarily Connecting Line Power	39
2.7	Installing the Tube Unit Support Arm	39
2.8	Preinstallation of the Tube Unit - Collimator	40
2.9	Installing the Tube Unit - Collimator on the Tube Unit Support Arm	40
2.10	Installing the Image Intensifier (I.I.)	41
2.11	Laying the Collimator Cables	41
2.12	Laying the High Voltage Cables	42
2.13	Laying the I.I. Cables	44
2.14	Connecting the Power Supply via the Generator	44
2.15	Installing the Measuring Chamber	45
2.16	Installing the Grid	46
2.17	Installing the Tilt Angle Indicator - Error Display	46
2.18	Installing the Cover Panels	47
2.19	Installing the Monitor Support Arm	47
2.20	Installing the Holder for the Flush Bowl	47
2.21	Sealing the Table Frame Cover Panel	48

1. TECHNICAL DATA

1.1 General Safety Information

Maintenance and repair may be performed only by an office that is authorized by the manufacturer.

In the Federal Republic of Germany, electrical installation of medically used rooms must conform to VDE Regulation 0107. In all other countries, the particular applicable national regulations take precedence and must be observed. These can be found in the system project plan.

During installation, it must be assured that all ground wire connections provided by the manufacturer must be connected prior to starting up the unit.

The ground wire between the individual components and the power supply must be connected as shown in the Wiring Diagram.

The regulations provided by the trade unions for occupational safety and prevention of accidents must be observed.

No work may be performed on parts that are under power (above 42 V).

This condition applies for both measurement and adjustment work steps. However, special care is required when performing these worksteps.

If the operating instructions call for voltage to be switched on for unit movements, the system must be shut down immediately following such tests.

The radiation regulations must be observed while making settings and checks that must be performed under X-radiation; radiation protective clothing must be worn.

1.2 Component Weights

Unit column	approx. 320 kg
Table	approx. 230 kg
Tube unit support arm	approx. 50 kg
Footswitch	approx. 5 kg
Total weight, incl. tube unit, collimator, adjustable Bucky and I.I.:	approx. 730 kg

1.3 Component Dimensions

Unit column with table and tube unit support arm on the pallet.

2050 mm x 1015 x 1800 mm

1.4 Packaging Dimensions and Weights

Unit column with table, incl. accessories	2050 mm x 1015 mm x 1890 mm approx. 900 kg
Transport carriage	1800 mm x 200 mm x 200 mm approx. 85 kg

1.5 Component Designations

(the illustration shows the right-handed version, the left-handed version is the mirror image)

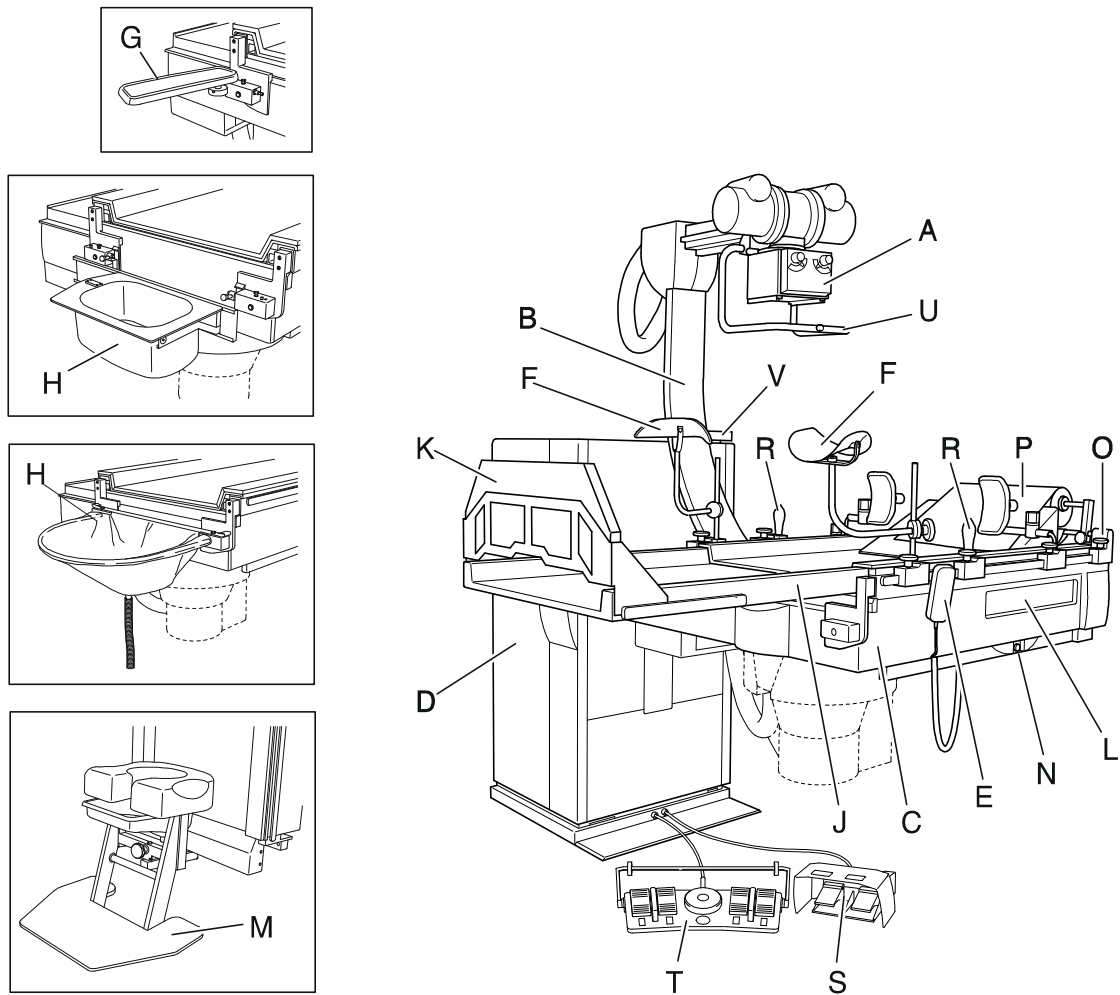

- A** X-ray tube unit - collimator
- B** Tube unit support arm, adjustable
- C** Unit table with four-way table movement
- D** Unit column
- E** Manual control unit
- F** Leg supports
- G** Elbow supports
- H** Flush bowl and rinse bag holder
- J** Table extension
- K** Footrest for table extension
- L** Cassette shaft cover
- M** Micturation seat
- N** Emergency stop switch
- O** Head cushion with holder
- P** Paper roll with holder
- R** Patient handgrips
- S** Footswitch for exposure and fluoroscopy
- T** Multi-function footswitch
- U** Grip handle
- V** Tilt angle display / position memory display / error display

1.6 Dimensional Drawing, Right-handed Version

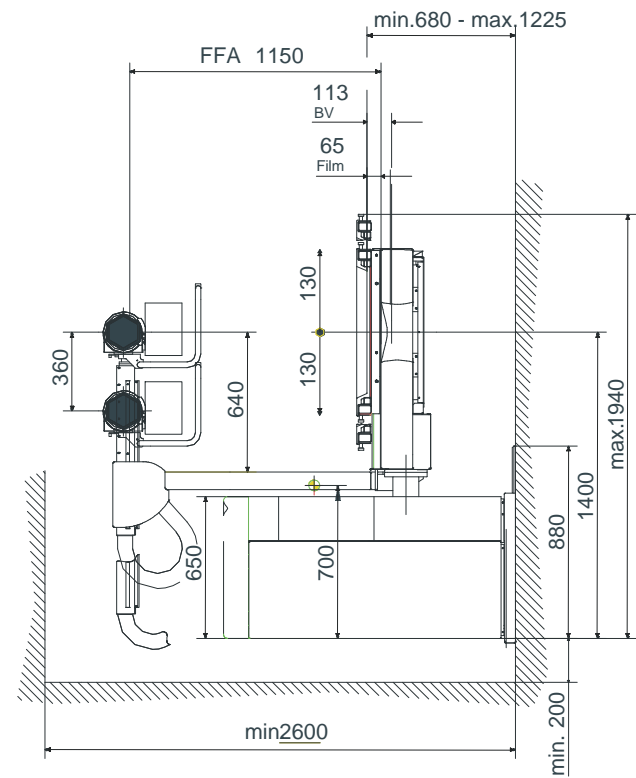

mm	inch
680	26.772
700	27.559
760	29.921
780	30.709
880	34.646
920	36.220
1150	45.276
1200	47.244
1225	48.228
1335	52.559
1340	52.756
1400	55.118
1450	57.087
1750	68.898
1940	76.378
2600	102.362

mm	inch
20	0.787
65	2.559
113	4.449
130	5.118
145	5.709
180	7.087
200	7.874
240	9.449
300	11.811
325	12.795
360	14.173
495	19.488
500	19.685
640	25.197
650	25.591
662	26.063

Der angegebene Schwerpunkt gilt ohne Ringkomponenten und Zubehör. Tisch horizontal in oberster Stellung, Röhrentragarm auf der Kopfseite.

The mentioned centre of gravity applies without X-ray components and accessories. Table horizontal in highest position, tube support arm at the head end.

Gewicht ca. 670 kg
weight approx. 670 kg

* gemäß DIN EN 349
according to DIN EN 349

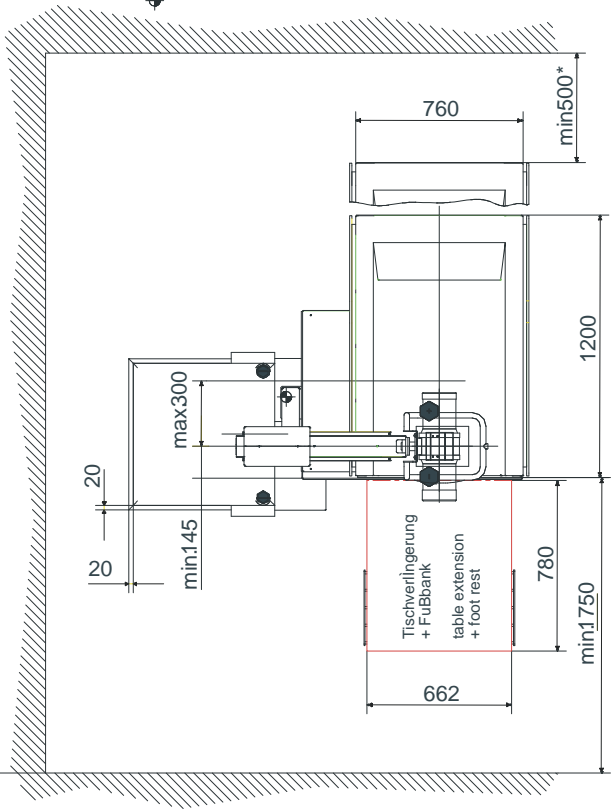
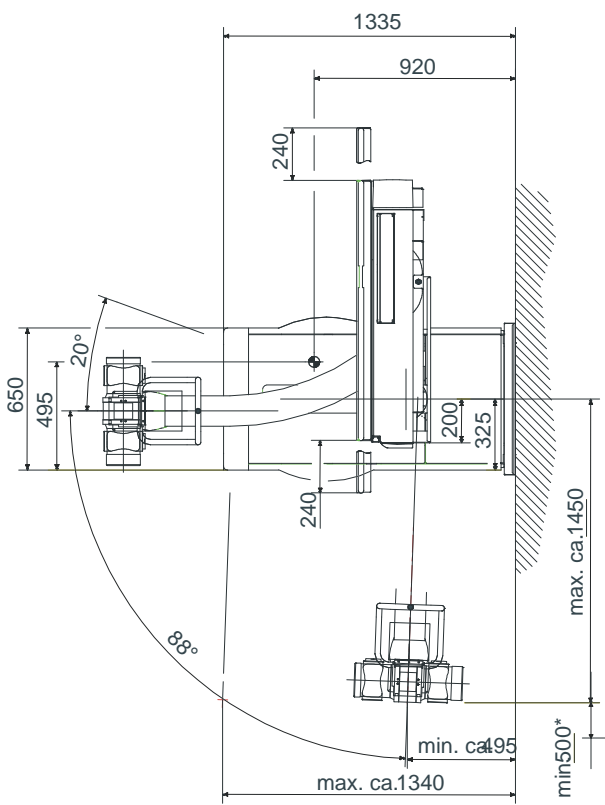

1.6.1 Dimensional Drawing, Left-handed Version

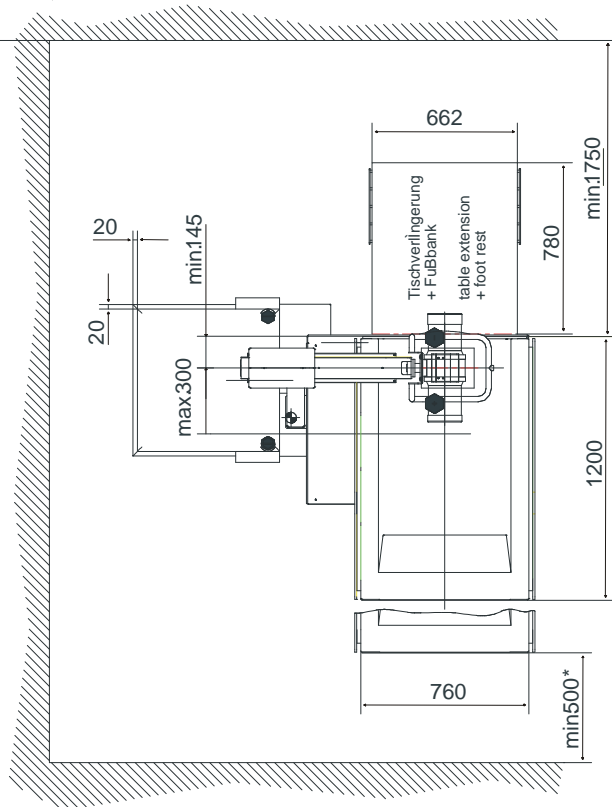
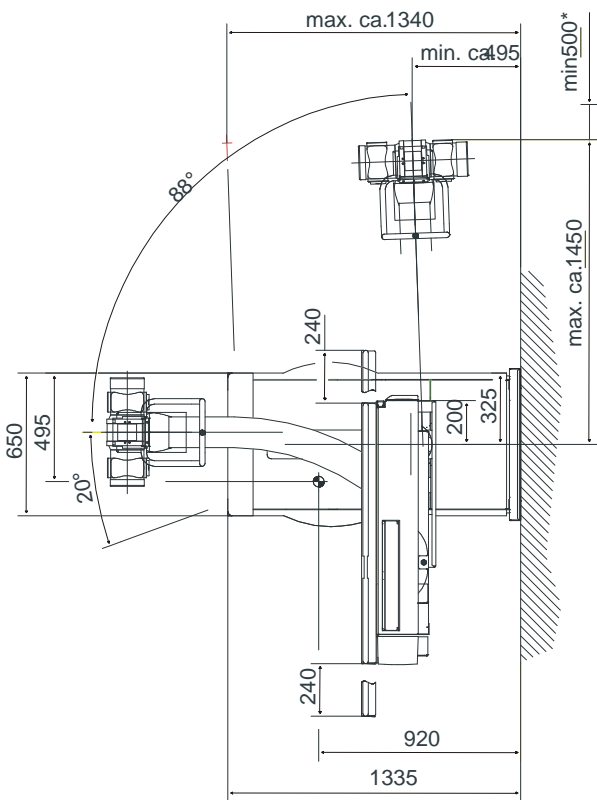
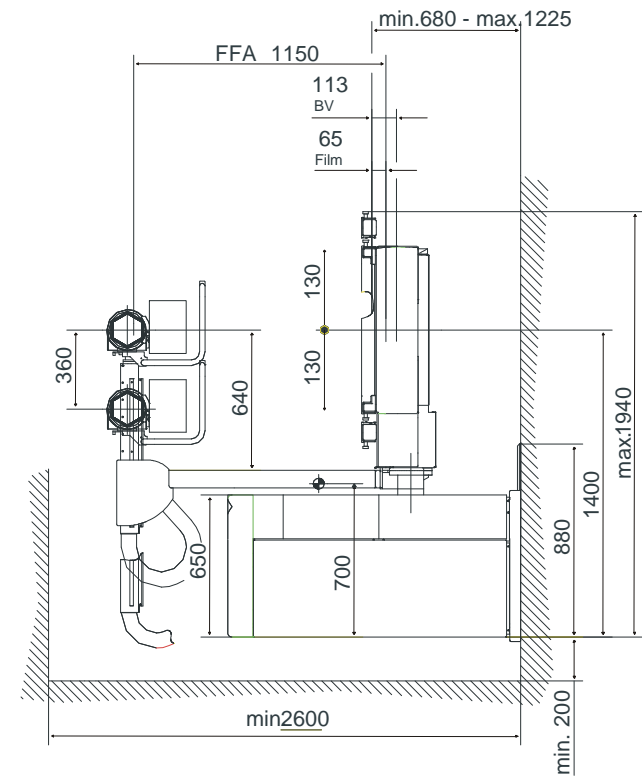

Der angegebene Schwerpunkt gilt ohne Röntgenkomponenten und Zubehör. Tisch horizontal in oberster Stellung, Röhrentragarm auf der Kopfseite.

The mentioned centre of gravity applies without X-ray components and accessories. Table horizontal in highest position, tube support arm at the head end.

Gewicht ca. 670 kg
weight approx. 670 kg

* gemäß DIN EN 349
according to DIN EN 349

mm	inch
680	26,772
700	27,559
760	29,921
780	30,709
880	34,646
920	36,220
1150	45,276
1200	47,244
1225	48,228
1335	52,559
1340	52,756
1400	55,118
1450	57,087
1750	68,898
1940	76,378
2600	102,362

mm	inch
20	0,787
65	2,559
113	4,449
130	5,118
145	5,709
180	7,087
200	7,874
240	9,449
300	11,811
325	12,795
360	14,173
495	19,488
500	19,685
640	25,197
650	25,591
662	26,063

1.6.2 Dimensional Drawing for Floor Mounting, Right-handed Version

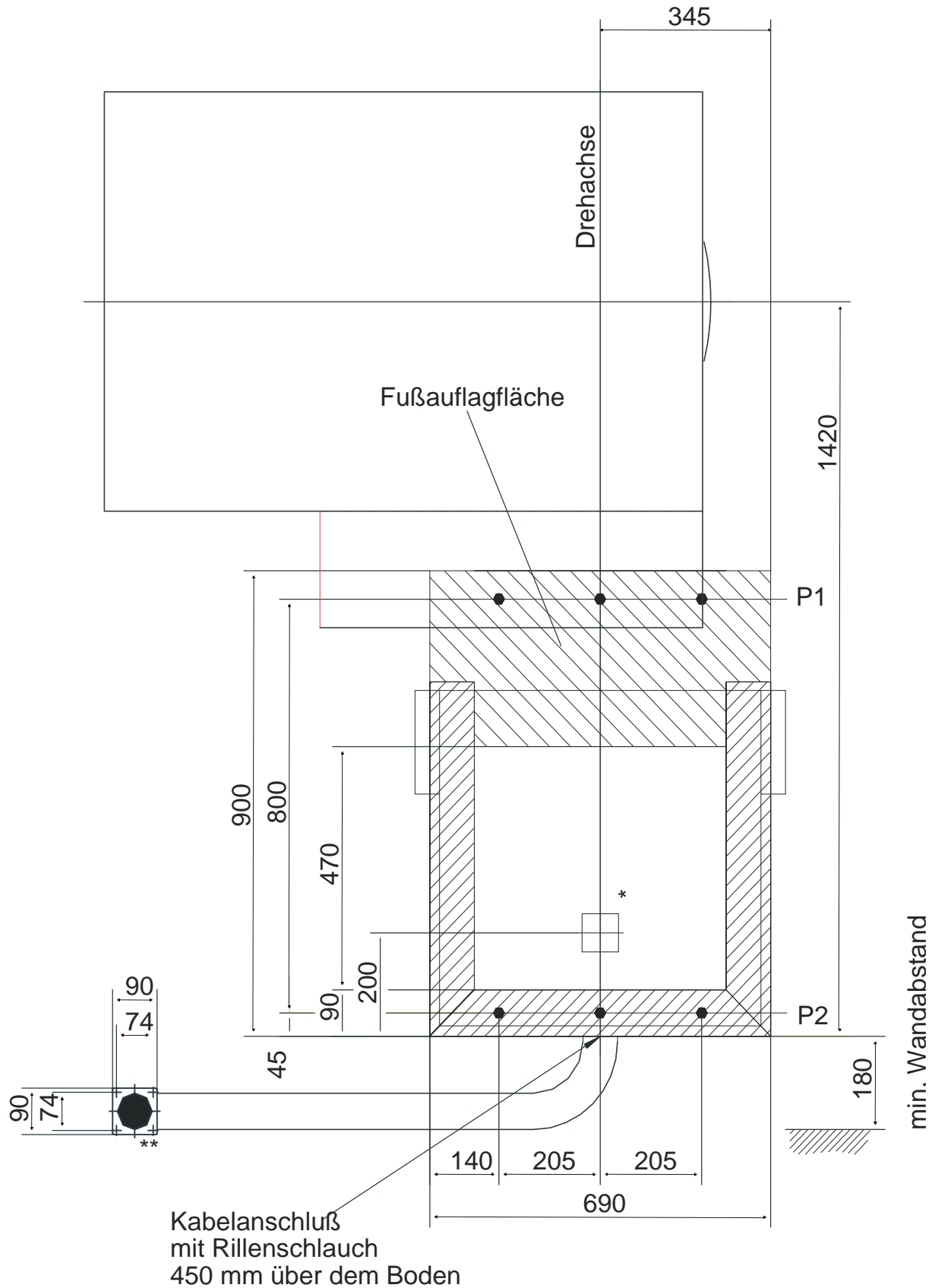

- * Cable intake through the floor
- ** End of flexible hose for wall connection of 2000 mm flexible hose length

1.6.3 Dimensional Drawing for Floor Mounting, Left-handed Version

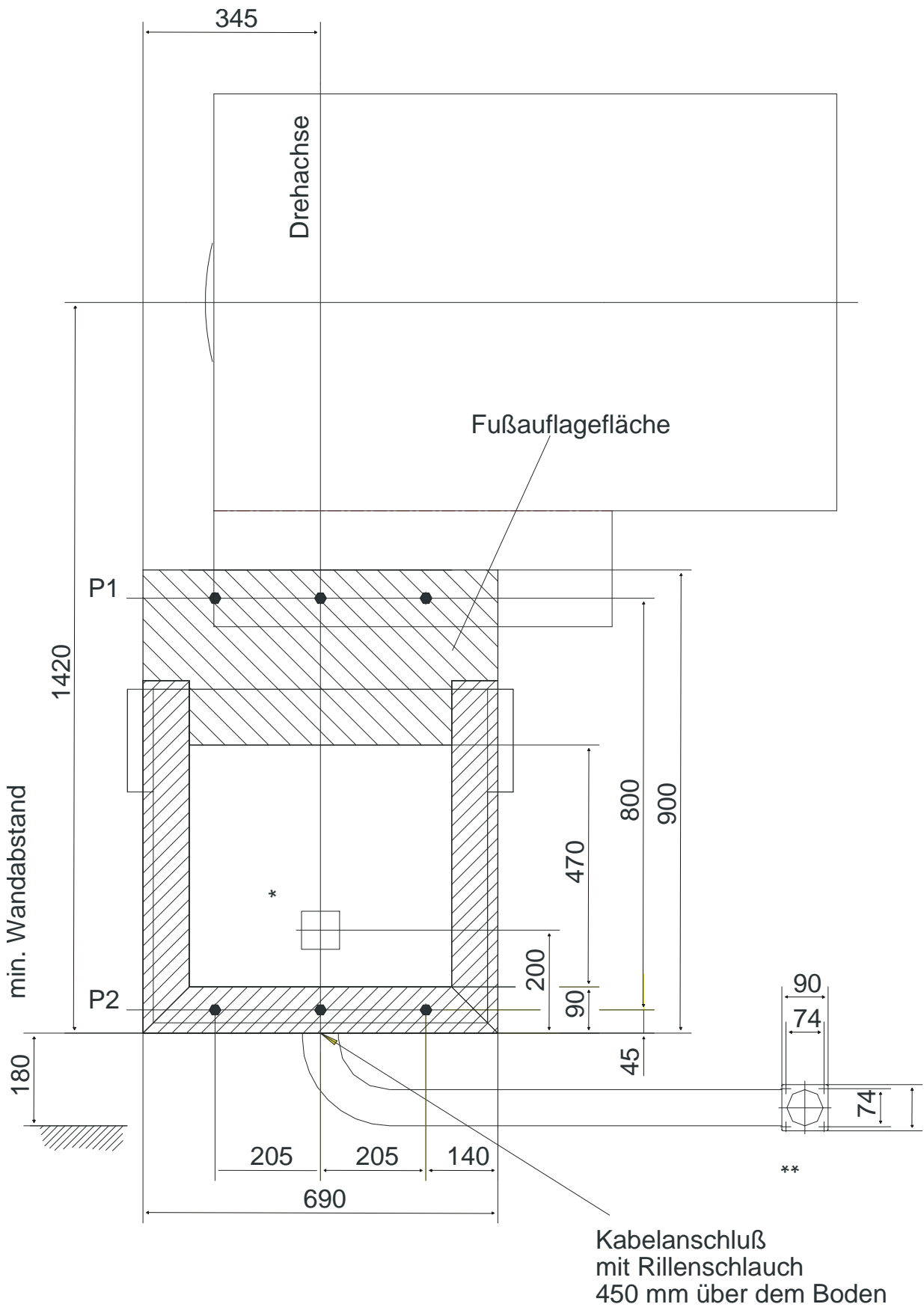

* Cable intake through the floor

** End of flexible hose for wall connection of 2000 mm flexible hose length

1.7 Cable Lengths of the High Voltage, Collimator, Bucky and Image Intensifier Cables

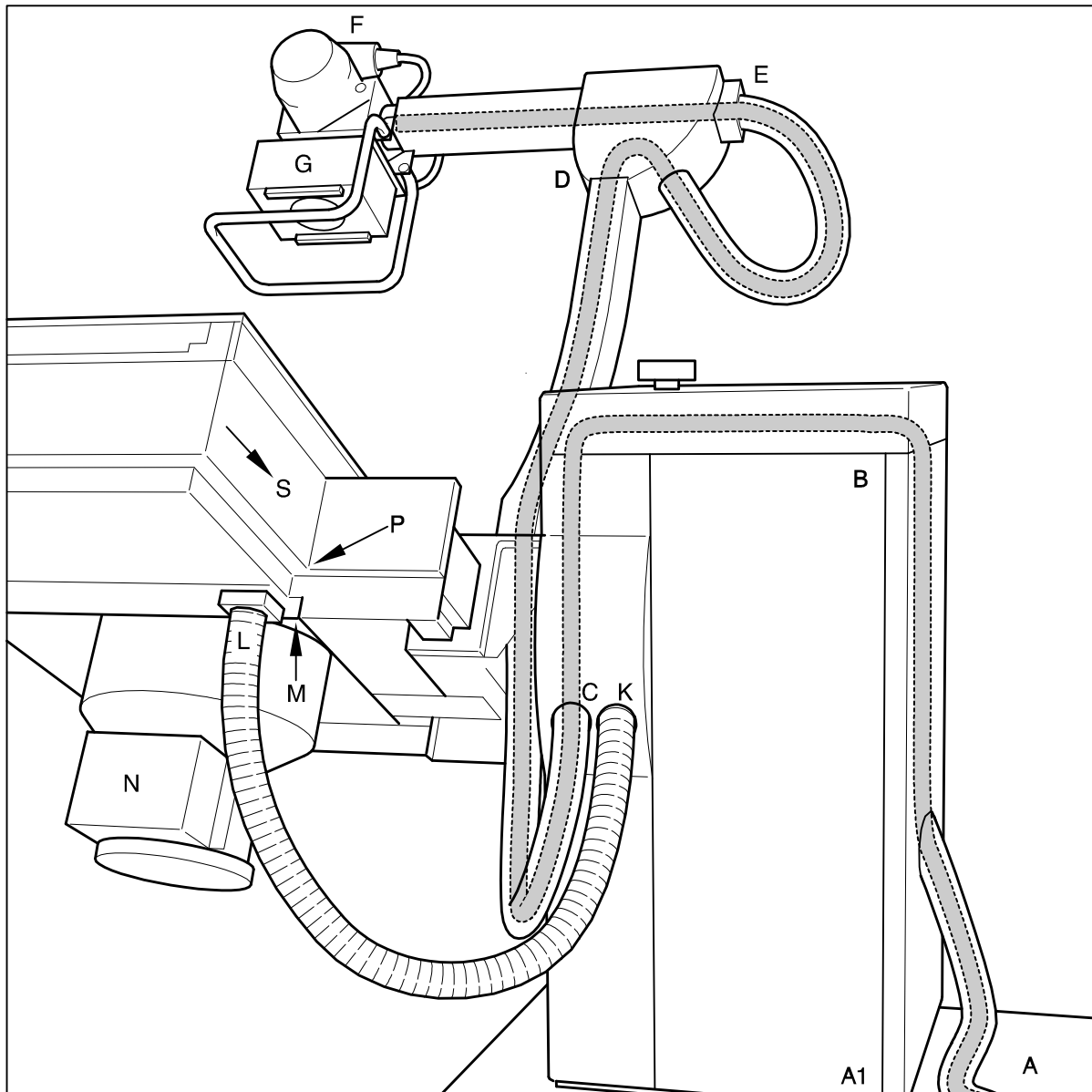

High voltage cables	A, C, D, E, F,	700 cm
Collimator cables	B, C, D, E, G,	650 cm
Bucky, measuring chamber	A, K, L, M, P, S,	490 cm
Image intensifier cables	A, K, L, M, N,	630 cm

1.8 Power Line Connection Data

Power lead-in must be routed over a 30 mA fault current interrupter that is provided by the customer. The room installation must comply with VDE 0107.

In all other countries outside the Federal Republic Germany, the legally specified country regulations take precedence and must be maintained.

Prerequisite:

The unit is designed for single-phase DC current with a fixed installation and for a fixed connection using an all-pole separator from the Network (IEC 601, Chapter 57.1).

During installation, it must be possible to adapt the power line voltage and frequency to correspond to the order.

Power connection:	1 N	115 /200/208/ 230/240 V AC
Frequency:		50 / 60 Hz
Nominal current (fuse):		13/7.5/7.2/6.5/6.25 A
Nominal line power:		1500 VA
Heat dissipation:		240 W

1.9 Required Special Tools

Torque wrench	50 Nm (5 mkp)
Masonry drill bit	12 mm dia.
Sista sanitary caulking	F 101
Special grease - Tunap Tungrease BS	Pa. Nr.: 9026 0001

1.10 Required Test Equipment

PC or laptop with color display (black/white is also sufficient, but operation is made more difficult); min. 486 processor; 16 MB RAM; with a 3 ½" diskette drive and hard drive.

Windows 3.x ; Win 95 operating system (Windows NT can cause difficulties with the Com interface).

Serial connection cable (9-pole, Sub-D connector to 9-pole Sub-D socket, 1-1 connection), length > 1m.

Spirit level

Tape measure

Multimeter test instrument

1.11 Conditions for Transport and Storage

Ambient temperature range	-25 C to 70 C
Relative humidity in the range	5% to 95%
Air pressure in the range	700 hPa to 1100 hPa

1.12 Operating Conditions

Ambient temperature range	10 C to 40 C
Relative humidity in the range	20% to 80%
Air pressure in the range	700 hPa to 1100 hPa

1.13 Circuit Diagram, Page 1

1.13.1 Description of Circuit Diagram

..... Circuit Diagram, Page 2

= AX Control unit

= system, designation

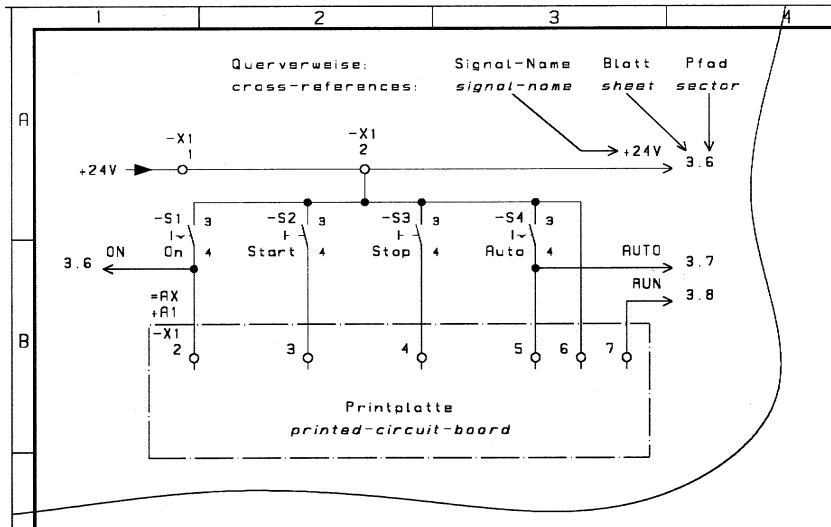

..... Circuit Diagram, Page 3

= AX + A2 Display unit

= system, + location, designation

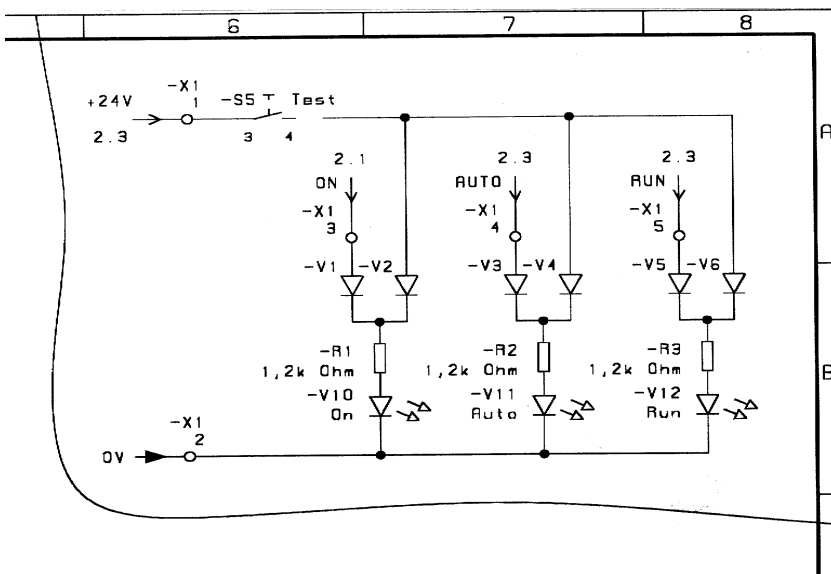

1.13.2 Contents of Circuit Diagram

1.13	Circuit Diagram, Page 2	Page	13
1.13	Circuit Diagram, Page 3	Page	14
1.13	Circuit Diagram, Page 4	Page	15
1.13	Circuit Diagram, Page 5	Page	16
1.13	Circuit Diagram, Page 6	Page	17
1.13	Circuit Diagram, Page 7	Page	18
1.13	Circuit Diagram, Page 8	Page	19
1.13	Circuit Diagram, Page 9	Page	20
1.13	Circuit Diagram, Page 10	Page	21
1.13	Circuit Diagram, Page 11	Page	22
1.13	Circuit Diagram, Page 12	Page	23
1.13	Circuit Diagram, Page 13	Page	24
1.13	Circuit Diagram, Page 14	Page	25
1.13	Circuit Diagram, Page 15	Collimator	Page 26

1.13 Circuit Diagram, Page 2

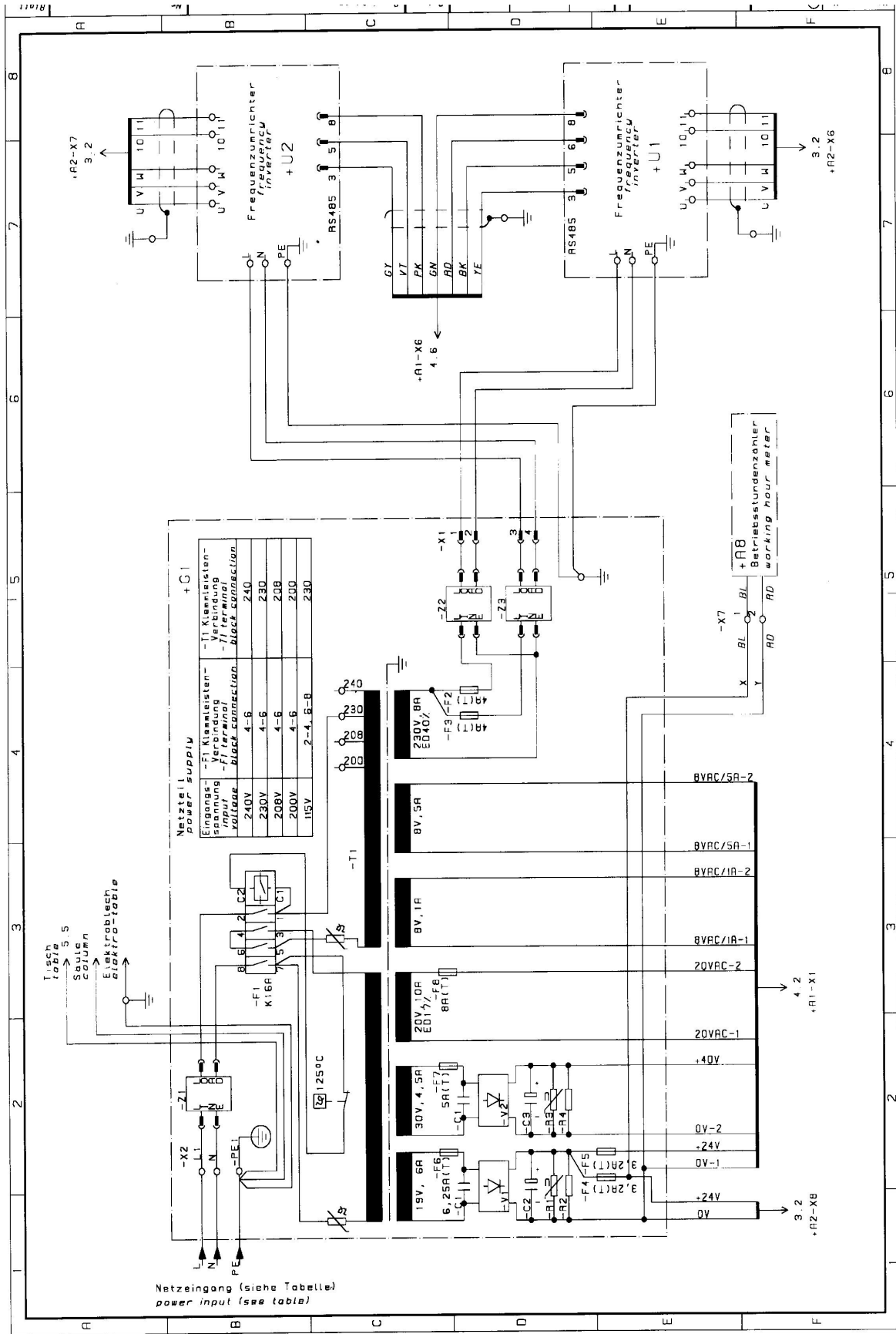

1.13 Circuit Diagram, Page 3

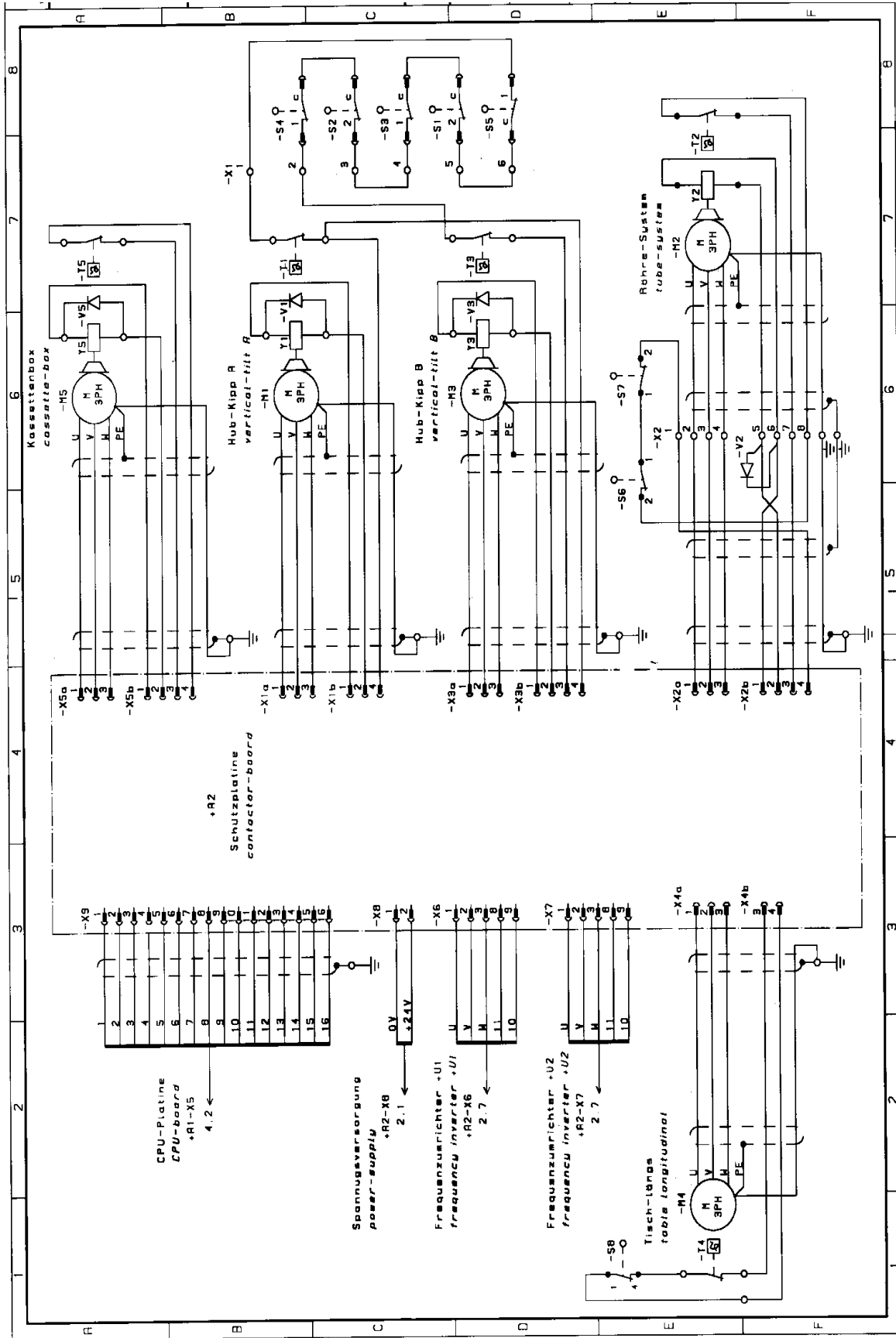

1.13 Circuit Diagram, Page 4

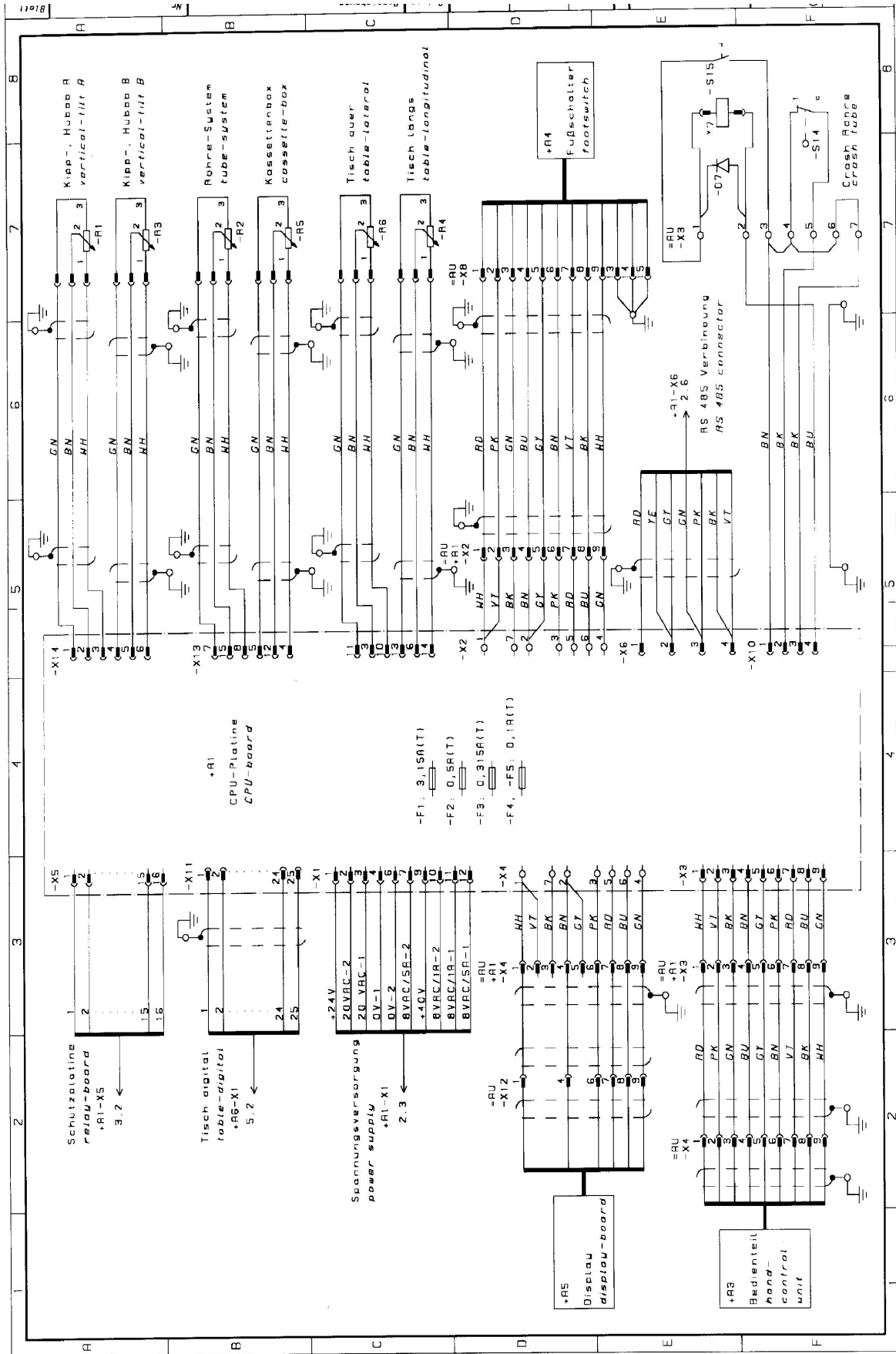

1.13 Circuit Diagram, Page 5

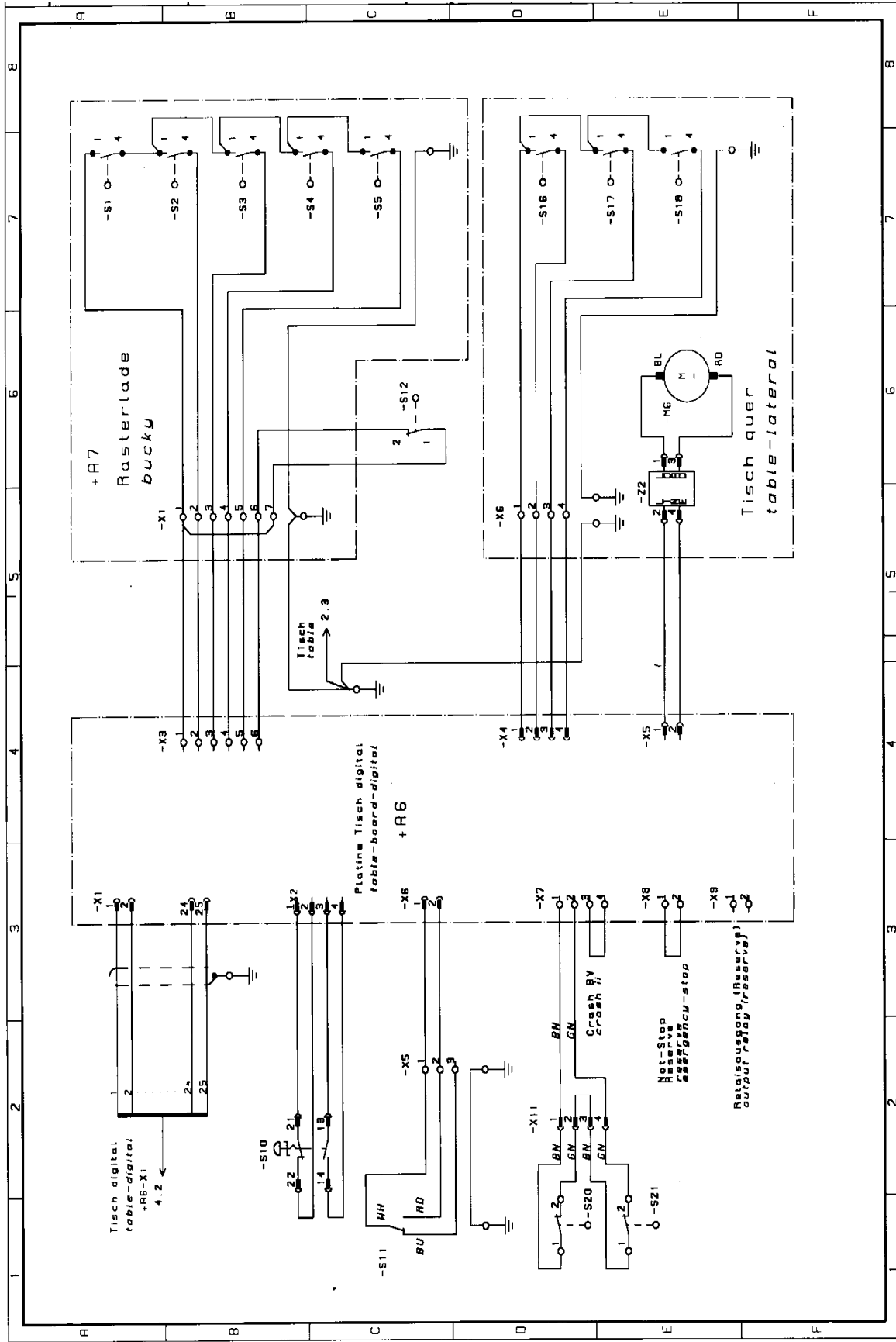

1.13 Circuit Diagram, Page 6

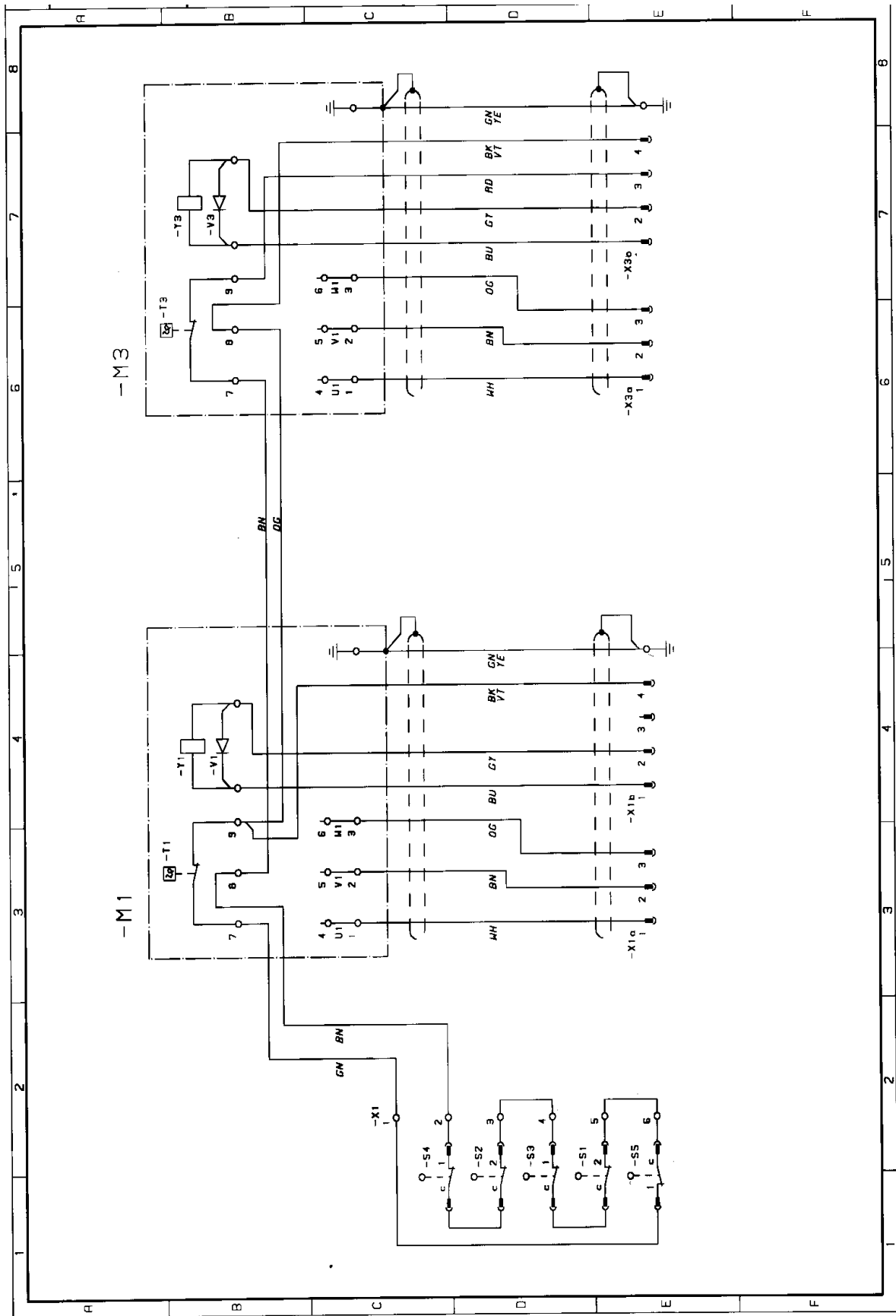

1.13 Circuit Diagram, Page 7

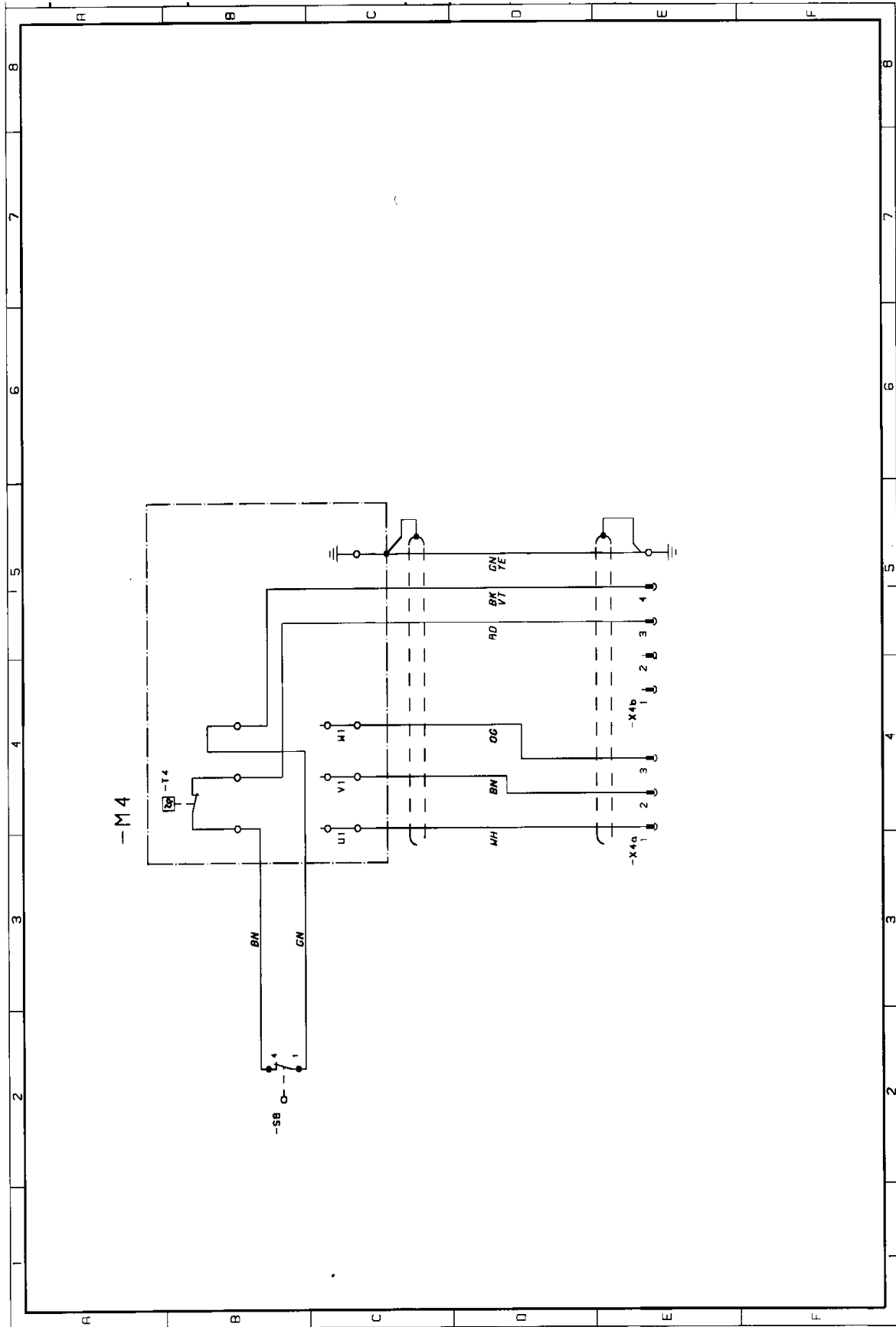

1.13 Circuit Diagram, Page 8

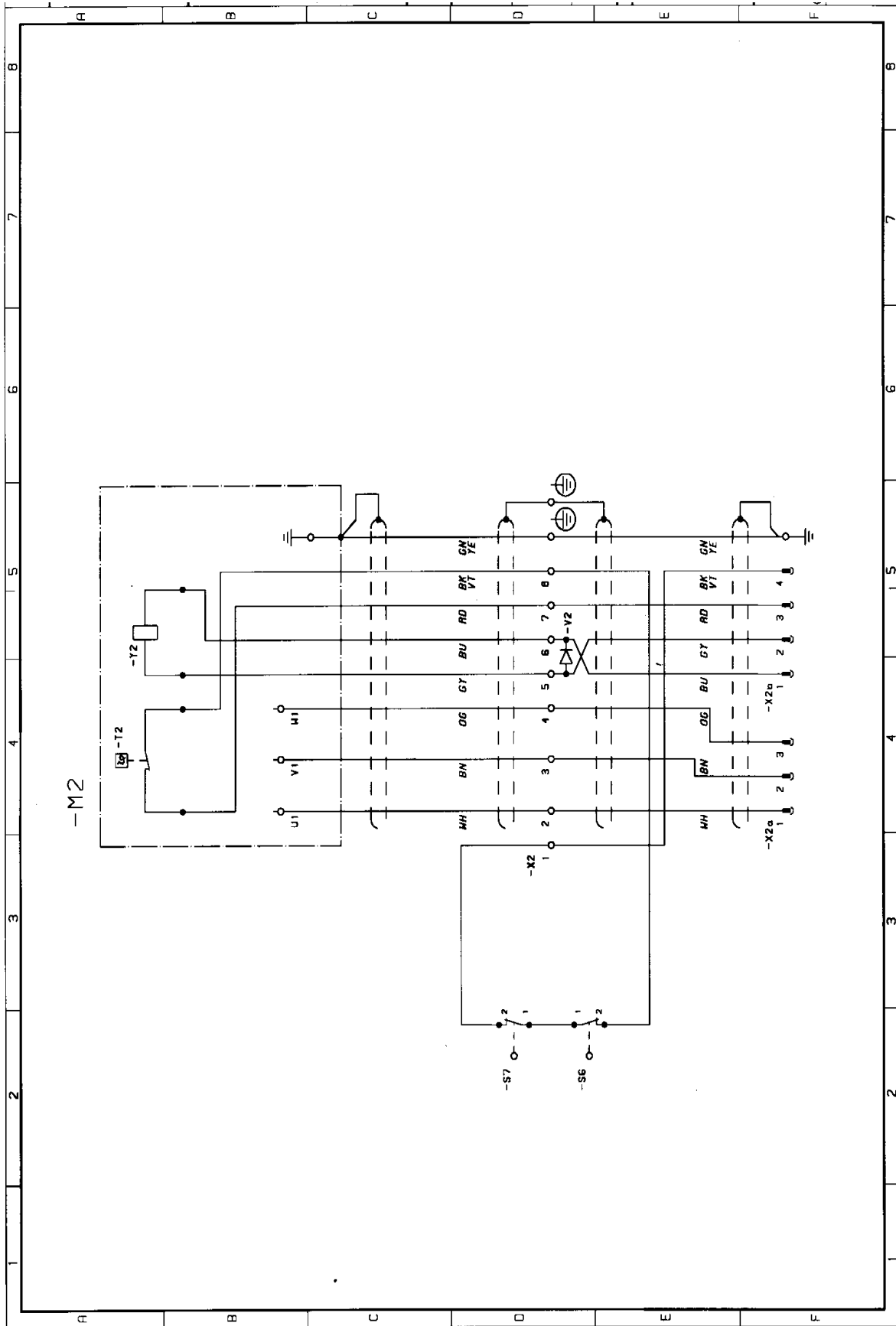

1.13 Circuit Diagram, Page 9

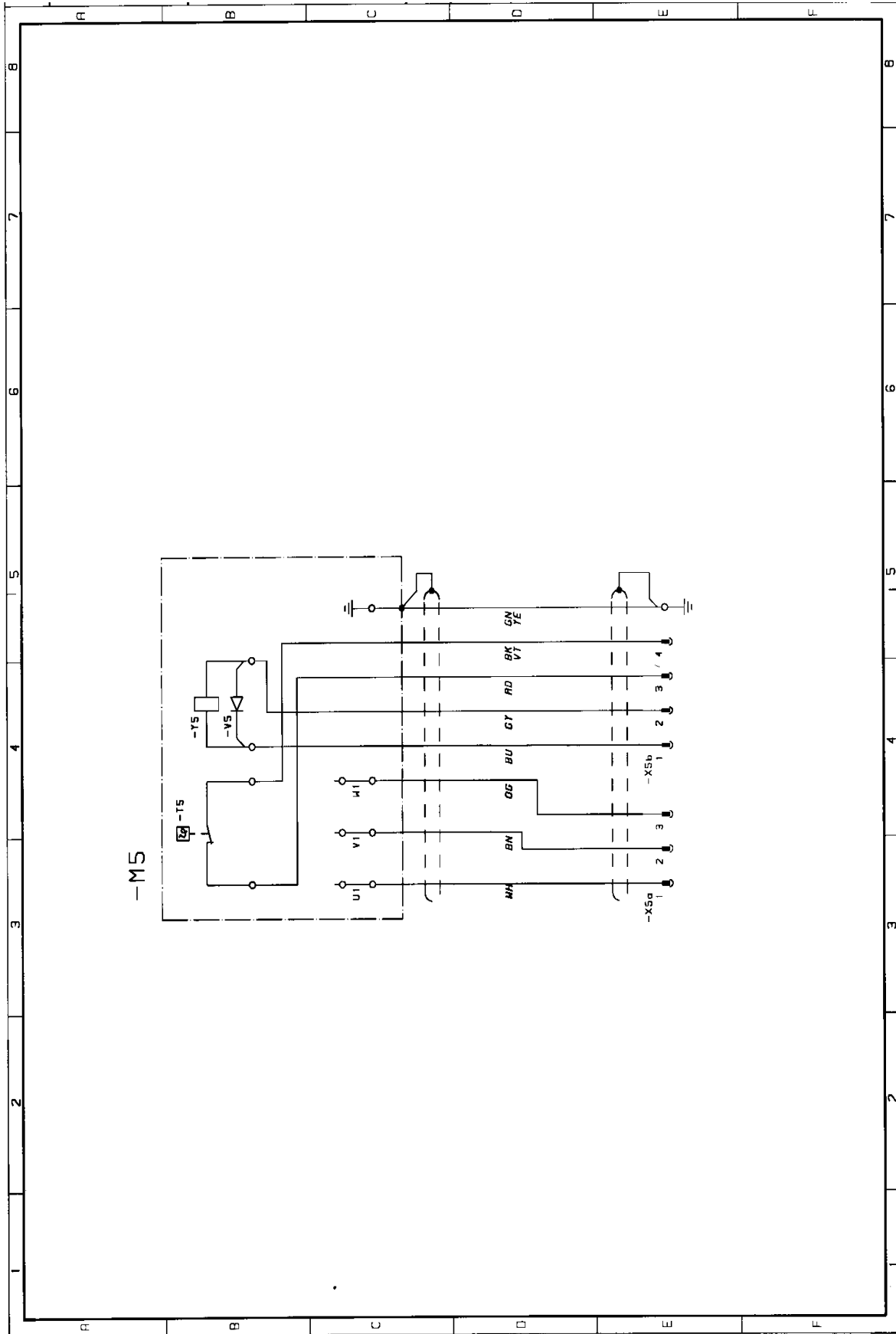

1.13 Circuit Diagram, Page 10

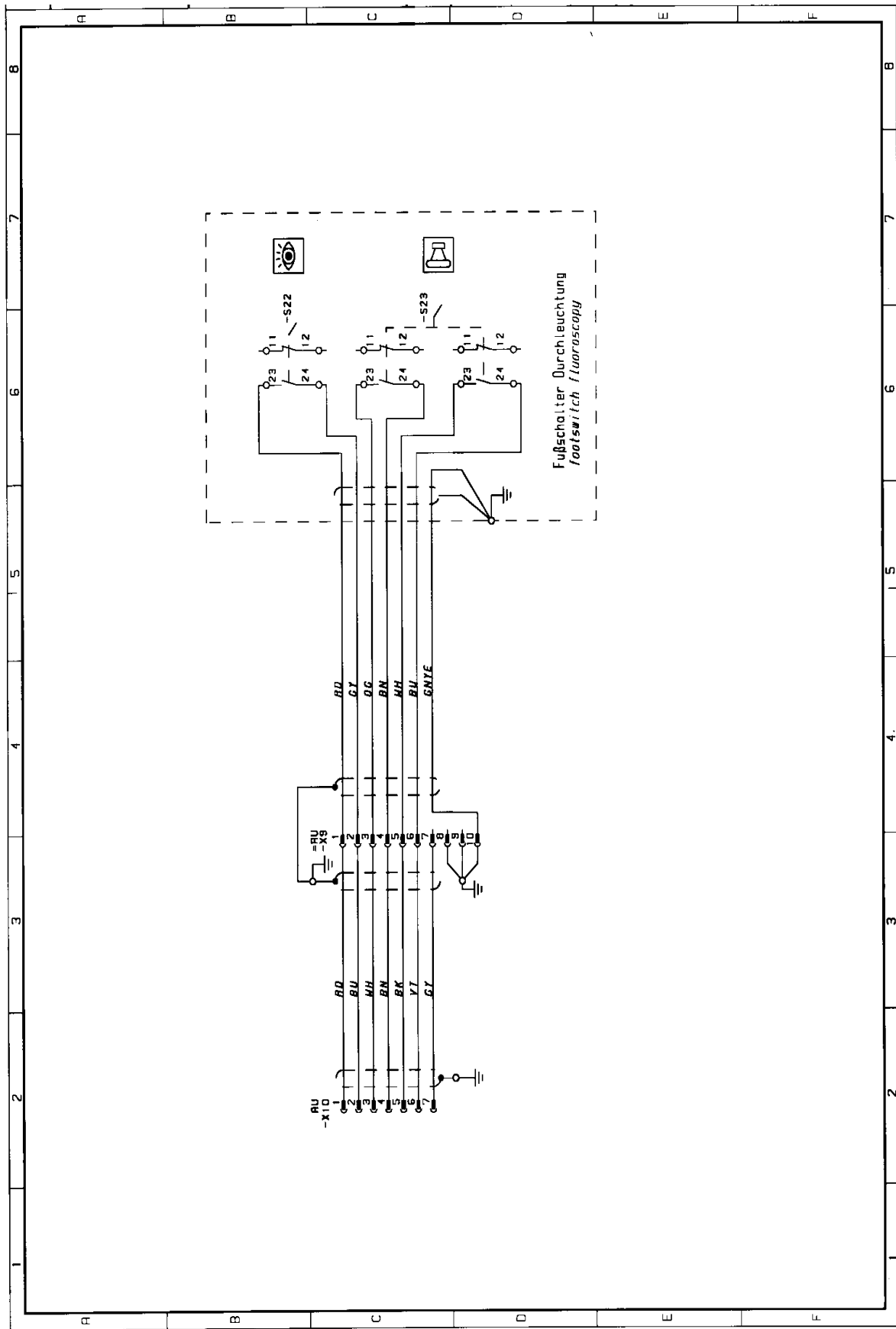

1.13 Circuit Diagram, Page 11

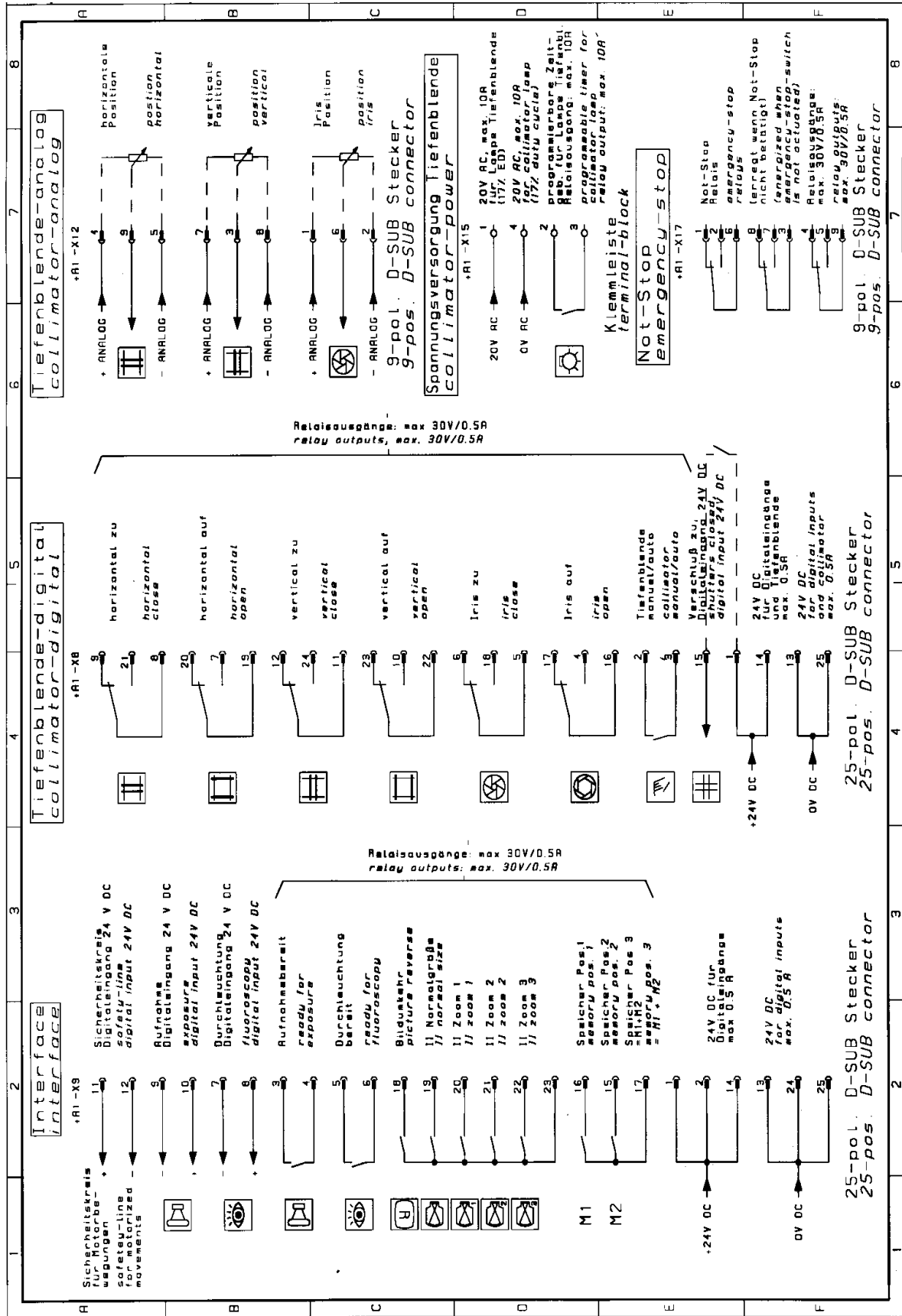

1.13 Circuit Diagram, Page 12

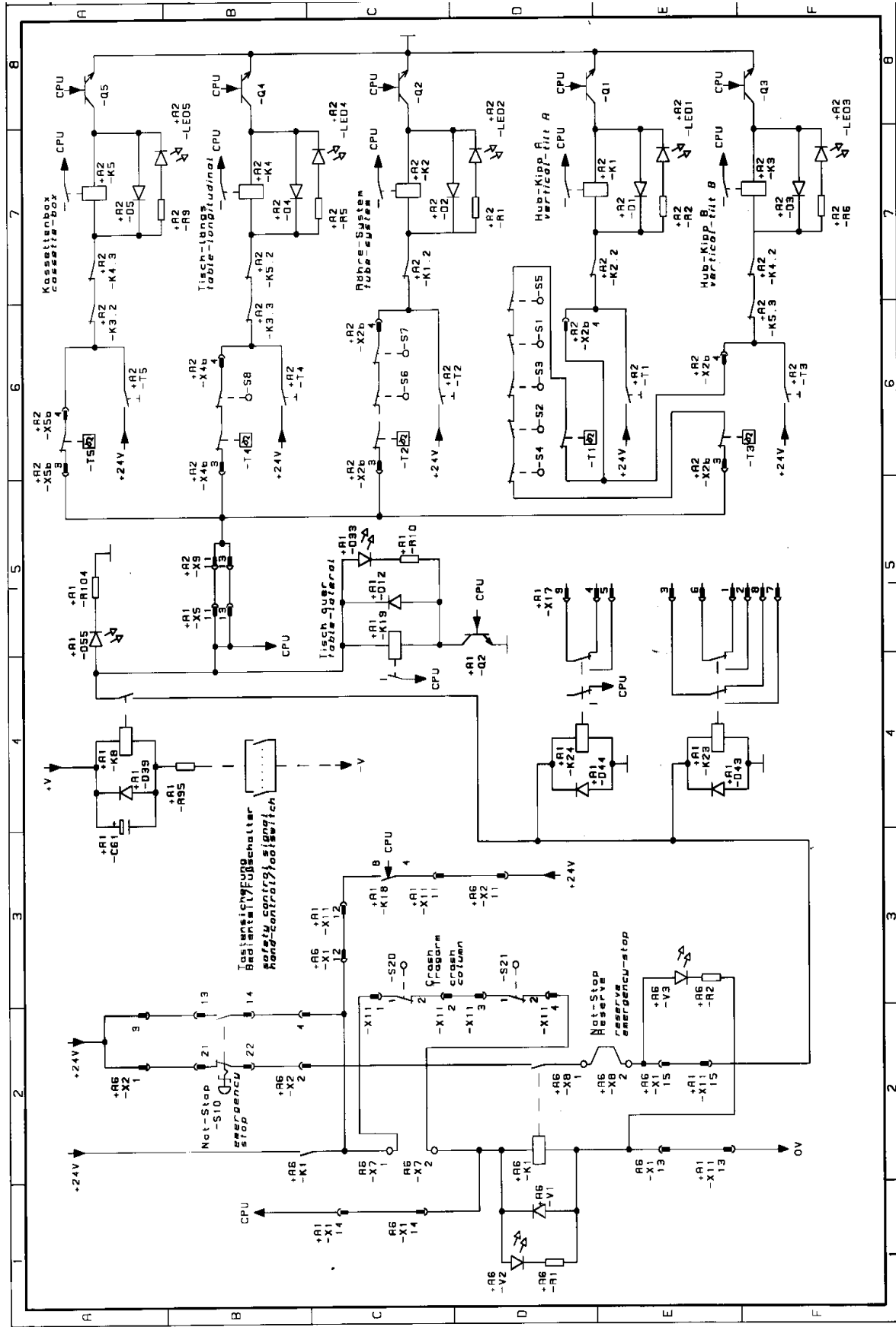

1.13 Circuit Diagram, Page 13

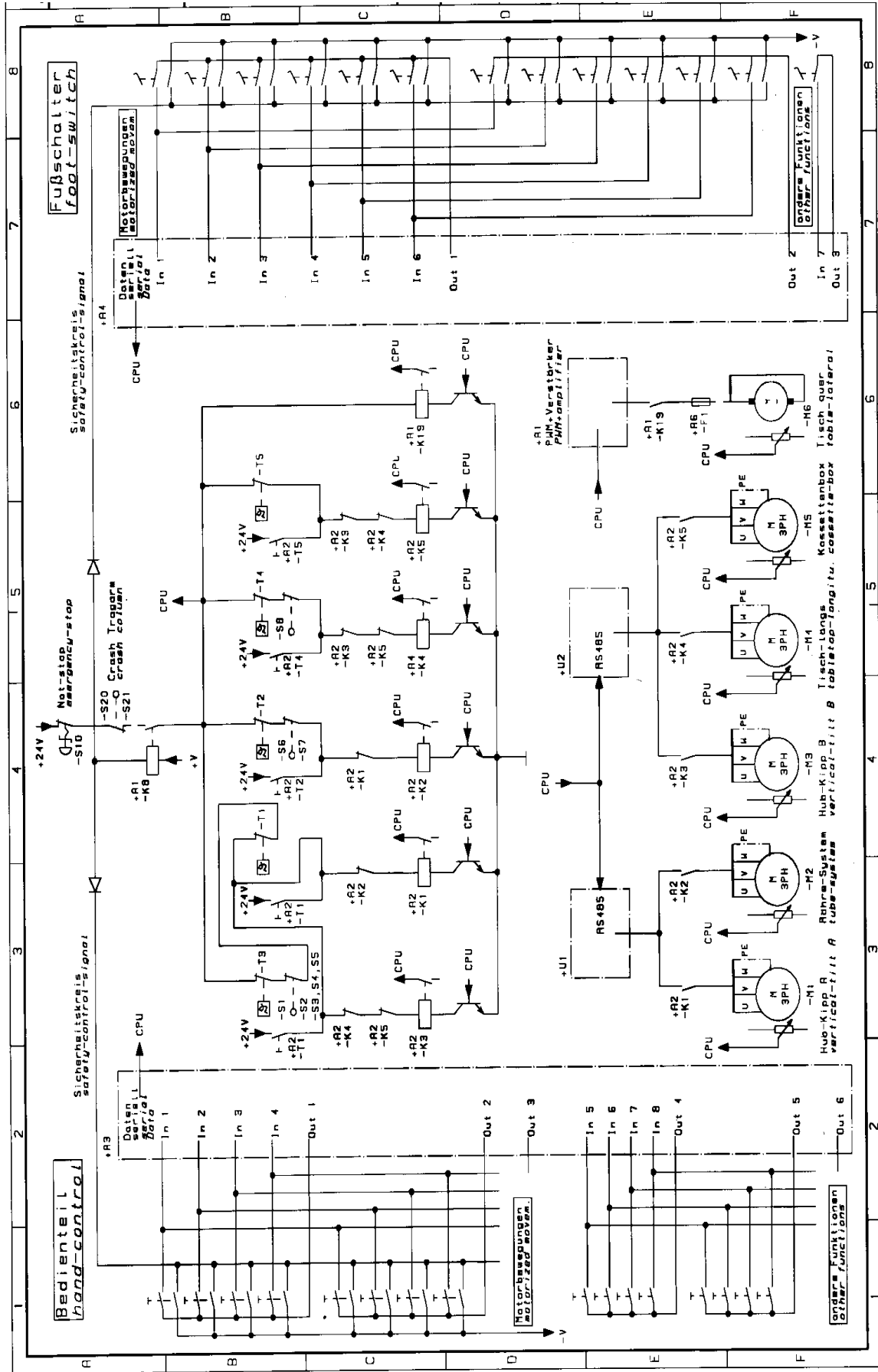

1.13 Circuit Diagram, Page 14

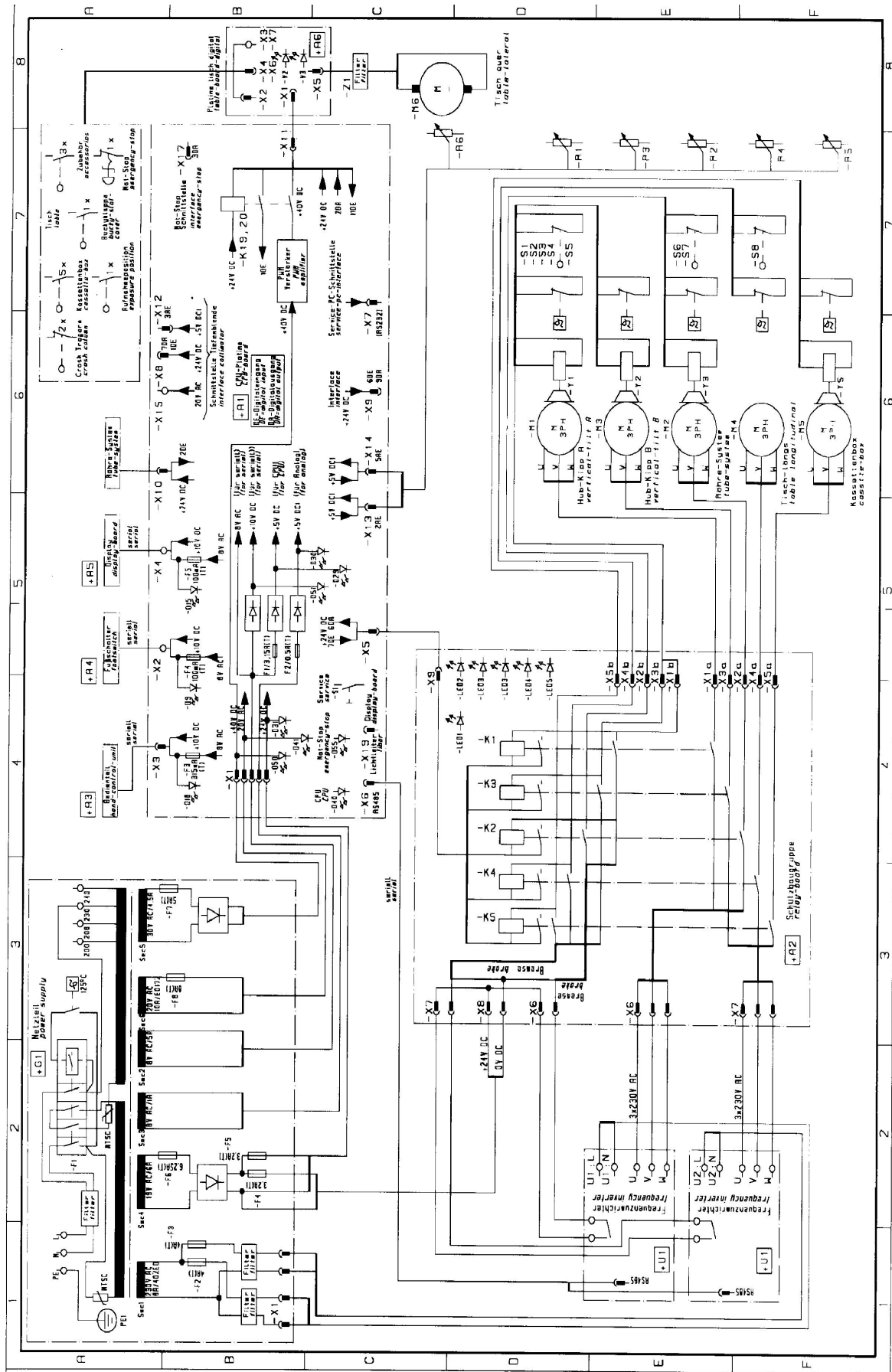

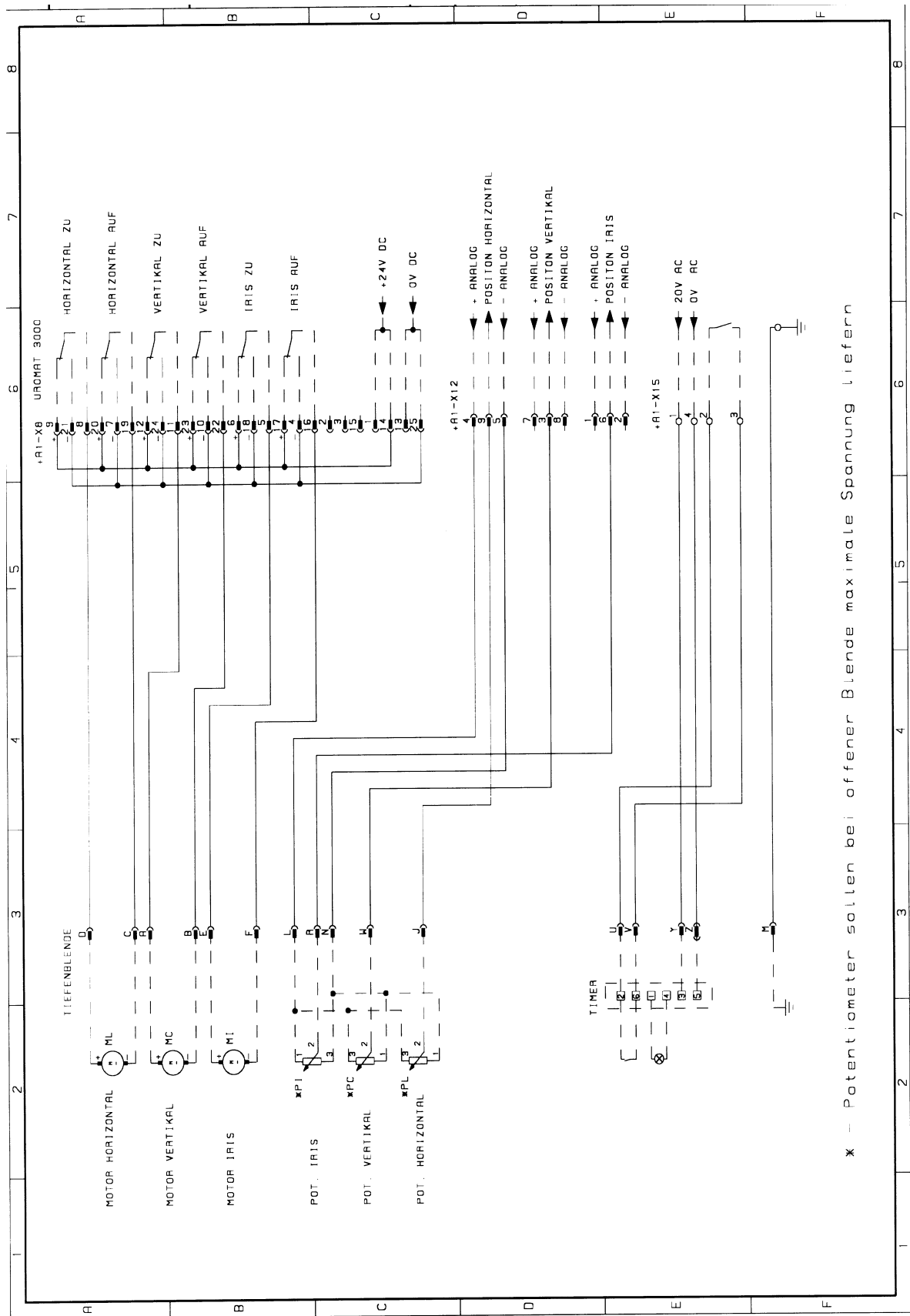

1.14 Component Designations for the Circuit Diagram

System Location	Component	Function
=AU		Uromat 3000
=AU	+A1	CPU board
=AU	+A1	-D9 LED, footswitch power supply
=AU	+A1	-D15 LED, display power supply
=AU	+A1	-D18 LED, control console power supply
=AU	+A1	-D29 LED, CPU power supply
=AU	+A1	-D30 LED, Analog power supply
=AU	+A1	-D31 LED, + 24 V power supply
=AU	+A1	-D33 LED, K19 relay activated
=AU	+A1	-D40 LED, CPU status
=AU	+A1	-D41 LED, 20VAC power supply
=AU	+A1	-D50 LED, +24V DC power supply
=AU	+A1	-D51 LED, +10V DC power s
=AU	+A1	-D55 LED, emergency stop
=AU	+A1	-F1 Fuse, CPU power supply
=AU	+A1	-F2 Fuse, analog power supply
=AU	+A1	-F3 Fuse, control console power supply
=AU	+A1	-F4 Fuse, footswitch power supply
=AU	+A1	-F5 Fuse, display power supply
=AU	+A1	-K8 Button fuse relay
=AU	+A1	-K19 Enable table transverse movement relay
=AU	+A1	-K20 Table, transverse, left, right movement relay
=AU	+A1	-K23 Emergency stop interface relay
=AU	+A1	-K24 Emergency stop interface relay
=AU	+A1	-Q2 Transistor for K19 pull-in relay
=AU	+A1	-S1 Service switch
=AU	+A1	-X1 Power supply plug-in connector
=AU	+A1	-X2 Footswitch plug-in connector
=AU	+A1	-X3 Control console plug-in connector
=AU	+A1	-X4 Display connector strip
=AU	+A1	-X5 Display connector strip
=AU	+A1	-X6 RS 485 plug-in connector
=AU	+A1	-X7 Service PC plug-in connector
=AU	+A1	-X8 Collimator plug-in connector
=AU	+A1	-X9 Interface plug-in connector
=AU	+A1	-X10 Tube unit system plug-in connector
=AU	+A1	-X11 Digital table plug-in connector
=AU	+A1	-X12 Collimator plug-in connector
=AU	+A1	-X13 Analog table plug-in connector
=AU	+A1	-X14 Analog column plug-in connector
=AU	+A1	-X15 Power supply terminal strip
=AU	+A1	-X17 Emergency stop plug-in connector
=AU	+A1	-X19 Display fiber-optic cable plug-in connector

System Location		Component	Function
=AU	+A2		Breaker board
=AU	+A2	-K1	Motor breaker for M1 motor
=AU	+A2	-K2	Motor breaker for M2 motor
=AU	+A2	-K3	Motor breaker for M3 motor
=AU	+A2	-K4	Motor breaker for M4 motor
=AU	+A2	-K5	Motor breaker for M5 motor
=AU	+A2	-LED1	Motor breaker LED - K1 energized
=AU	+A2	-LED2	Motor breaker LED - K2 energized
=AU	+A2	-LED3	Motor breaker LED - K3 energized
=AU	+A2	-LED4	Motor breaker LED - K4 energized
=AU	+A2	-LED5	Motor breaker LED - K5 energized
=AU	+A2	-LED6	+24V power supply LED
=AU	+A2	-Q1	Transistor for K1 breaker
=AU	+A2	-Q2	Transistor for K2 breaker
=AU	+A2	-Q3	Transistor for K3 breaker
=AU	+A2	-Q4	Transistor for K4 breaker
=AU	+A2	-Q5	Transistor for K5 breaker
=AU	+A2	-T1	M1 safety circuit override button
=AU	+A2	-T2	M2 safety circuit override button
=AU	+A2	-T3	M3 safety circuit override button
=AU	+A2	-T4	M4 safety circuit override button
=AU	+A2	-T5	M5 safety circuit override button
=AU	+A2	-X1a	M1 power supply plug-in connector
=AU	+A2	-X1b	M1 brake safety switch plug-in connector
=AU	+A2	-X2a	M2 power supply plug-in connector
=AU	+A2	-X2b	M2 brake safety switch plug-in connector
=AU	+A2	-X3a	M3 power supply plug-in connector
=AU	+A2	-X3b	M3 brake safety switch plug-in connector
=AU	+A2	-X4a	M4 brake safety switch plug-in connector
=AU	+A2	-X4b	M4 brake safety switch plug-in connector
=AU	+A2	-X5a	M5 power supply plug-in connector
=AU	+A2	-X5b	M5 brake safety switch plug-in connector
=AU	+A2	-X6	+U1 frequency converter plug-in connector
=AU	+A2	-X7	+U2 frequency converter plug-in connector
=AU	+A2	-X8	+24V DC power supply plug-in connector
=AU	+A2	-X9	CPU board plug-in connector
=AU	+A3		Control unit
=AU	+A4		Footswitch
=AU	+A5		Display
=AU	+A6		Digital table board
=AU	+A6	-V2	LED, K1 relay energized
=AU	+A6	-V3	LED, emergency stop not pressed and K1 energized
=AU	+A6	-X1	CPU board cable plug-in connector
=AU	+A6	-X2	Emergency stop switch plug-in connector

System Location		Component	Function
=AU	+A6	-X3	Terminal strip for Bucky
=AU	+A6	-X4	Plug-in connectors for accessories
=AU	+A6	-X5	Table, transverse motor plug-in connector
=AU	+A6	-X6	Bucky shaft cover plug-in connector
=AU	+A6	-X7	Support arm collision, I.I. collision terminal strip
=AU	+A6	-X8	Spare emergency stop plug-in connector
=AU	+A7		Bucky
=AU	+A7	-S1	Cassette inserted switch
=AU	+A7	-S2	24x43 cassette switch
=AU	+A7	-S3	30x43 cassette switch
=AU	+A7	-S4	24x30 cassette switch
=AU	+A7	-S5	18x43 cassette switch
=AU	+A8		Operating hours counter
=AU	+G1		Power supply
=AU	+G1	-F1	Trip breaker
=AU	+G1	-F2	+U1 frequency converter fuse
=AU	+G1	-F3	+U2 frequency converter fuse
=AU	+G1	-F4	Fuse for breaker, motor brake
=AU	+G1	-F5	Fuse for inputs/outputs
=AU	+G1	-F6	+24V power supply fuse
=AU	+G1	-F7	Table transverse power supply fuse
=AU	+G1	-F8	Collimator power supply fuse
=AU	+G1	-PE1	Main grounding stud
=AU	+G1	-T1	Isolation transformer
=AU	+G1	-X1	Frequency converter plug-in connector
=AU	+G1	-X2	Power supply terminal strip
=AU	+G1	-Z1	Power input filter
=AU	+G1	-Z2	+U2 frequency converter filter
=AU	+G1	-Z3	+U1 frequency converter filter
=AU	+U1		Frequency converter
=AU	+U2		Frequency converter
=AU		-M1	Lift motor tilt A
=AU		-M2	Tube unit system motor
=AU		-M3	Lift motor tilt B
=AU		-M4	Table longitudinal motor
=AU		-M5	Cassette box motor
=AU		-M6	Table transverse motor
=AU		-R1	Lift motor tilt A potentiometer
=AU		-R2	Tube unit system motor potentiometer
=AU		-R3	Lift motor tilt B potentiometer
=AU		-R4	Table longitudinal motor potentiometer

System Location	Component	Function
=AU	-R5	Cassette box motor potentiometer
=AU	-R6	Table transverse motor potentiometer
=AU	-S1	M1 spindle nut safety switch
=AU	-S2	M3 spindle nut safety switch
=AU	-S3	M1 counterweight safety switch
=AU	-S4	M3 counterweight safety switch
=AU	-S5	Vertical movement safety switch
=AU	-S6	Tube unit system safety switch, foot end
=AU	-S7	Tube unit system safety switch, head end
=AU	-S8	Table longitudinal safety switch
=AU	-S10	Emergency switch
=AU	-S11	Bucky shaft cover switch
=AU	-S12	System cassette exposure position switch
=AU	-S14	Tube unit support arm exposure position switch
=AU	-S15	Tube unit support arm movement switch
=AU	-S16	Accessory switch
=AU	- S17	Accessory switch
=AU	- S18	Accessory switch
=AU	- S20	Support arm collision switch
=AU	- S21	Support arm collision switch
=AU	- S22	Fluoroscopy switch
=AU	- S23	Exposure switch
=AU	- T1	Lift motor tilt A thermoswitch
=AU	- T2	Tube unit system motor thermoswitch
=AU	- T3	Lift motor tilt B thermoswitch
=AU	- T4	Table longitudinal motor thermoswitch
=AU	- T5	Tube unit system motor thermoswitch
=AU	- T6	Table transverse motor thermoswitch
=AU	- X1	Lift, tilt movement safety circuit connector strip
=AU	- X2	Tube unit system motor connector strip
=AU	- X3	Tube unit support arm connector strip
=AU	- X4	Control unit plug-in connector
=AU	- X5	Bucky shaft cover connector strip
=AU	- X6	Accessories connector strip
=AU	- X7	Operating hours counter connector strip
=AU	- X8	Footswitch plug-in connector
=AU	- X9	Fluoro plug-in connector (table)
=AU	- X10	Fluoro connector (electronics panel)
=AU	- X11	Support arm collision plug-in connector
=AU	- X12	Display plug-in connector
=AU	- Y1	M1 motor brake
=AU	- Y2	M2 motor brake
=AU	- Y3	M3 motor brake
=AU	- Y5	M5 motor brake
=AU	- Y7	Tube unit support arm lift magnet
=AU	- Z1	Table transverse motor filter

1.15 Function Description of the Controller

a. System Overview

The electronic controller for the UROMAT 3000 is comprised of a max. of 5 units that are connected to each other via a bus.

UNIT	FUNCTION	LOCATION	REMARK
CPU board	Central unit for the entire controller with all interfaces.	Behind the cover panel, top.	All connectors on the CPU board are labeled.
Breaker board	Board with 5 breakers for the 5 AC motors.	Behind the cover panel, below the CPU board.	
Footswitch	Operation using pedals, equivalent to control unit, but does not have all functions.	Metal housing on the floor, connected to the CPU board via cables.	If there is a foot-switch, not absolutely necessary for operation.
Control unit	Portable manual control unit with all functions.	External, connected by a spiral cable to the CPU.	If there is a foot-switch, not absolutely necessary for operation.
Display unit	Display of the tilt angle and of various statuses.	Permanently mounted on the housing. Connected to the CPU by cable.	Not absolutely necessary for operation.

Additional peripheral equipment can be connected via the USS interface.

All interfaces are located on the CPU board:

INTERFACE	FUNCTION	MODE	REMARK
MOTRON bus	Connection of the CPU in the star configuration to the display unit, control unit and footswitch.	Serial, two-wire bit bus via optocoupler with full duplex connection.	
USS bus	Connection to the frequency converters.	Serial two-wire bit bus via RS485 with full duplex connection with USS protocol.	
Fiber optic	Connection to status display (customer request)	Optical serial bus with USS protocol.	1 direction only: write!

b. Boards

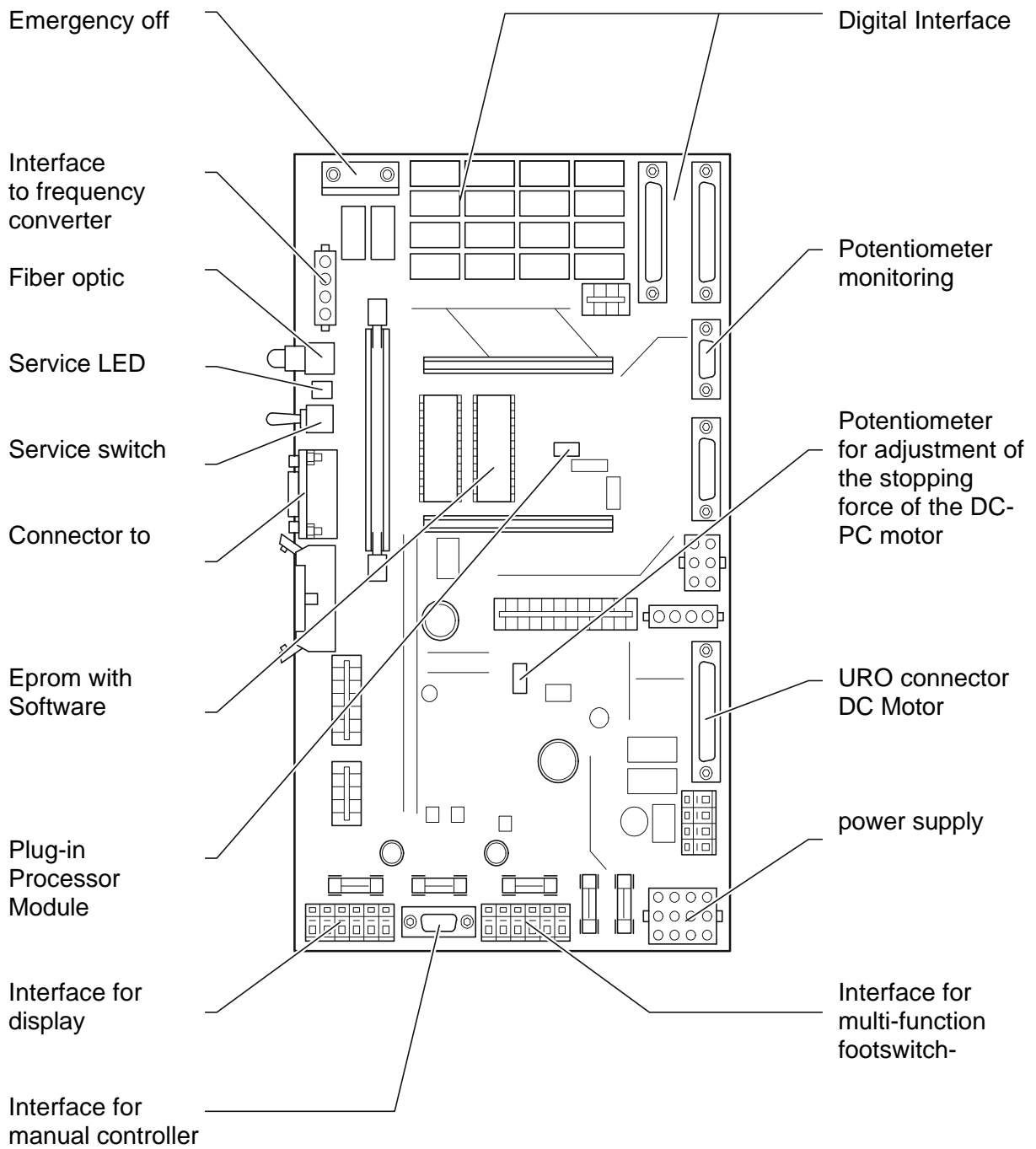

CPU Board

5 buttons with LED
to freely move
out of the limit
positions

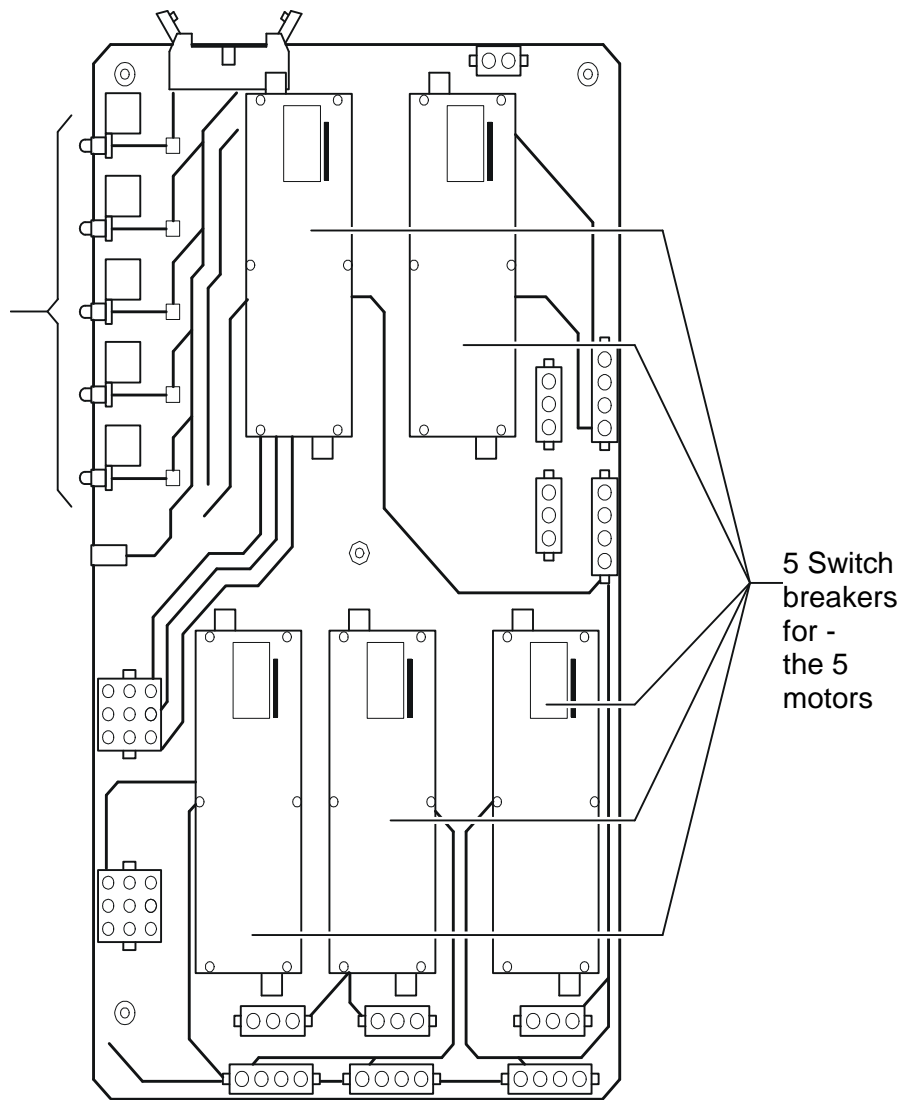

5 Switch
breakers
for -
the 5
motors

Breaker Board

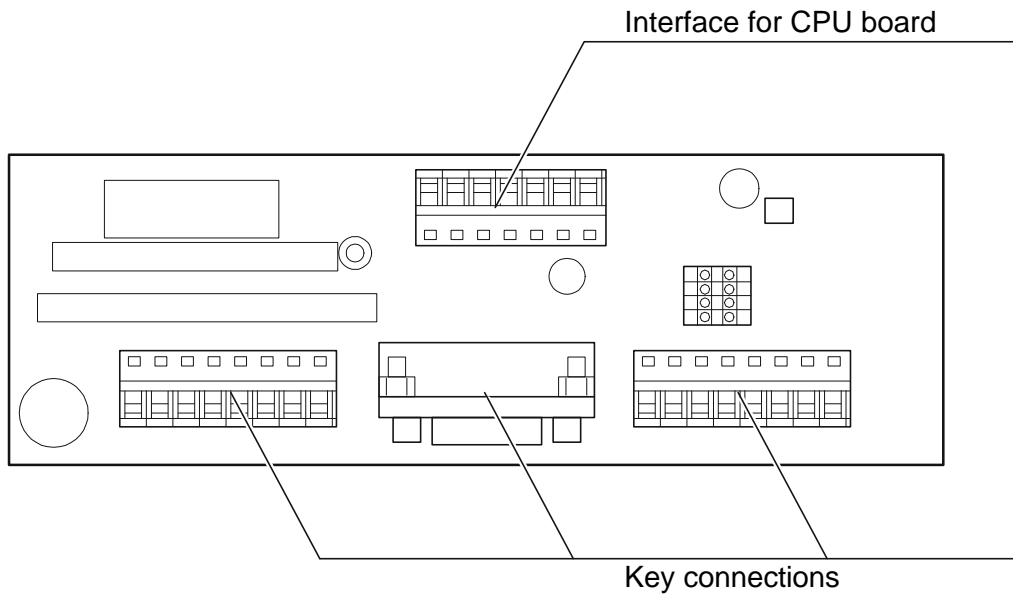

Footswitch Board

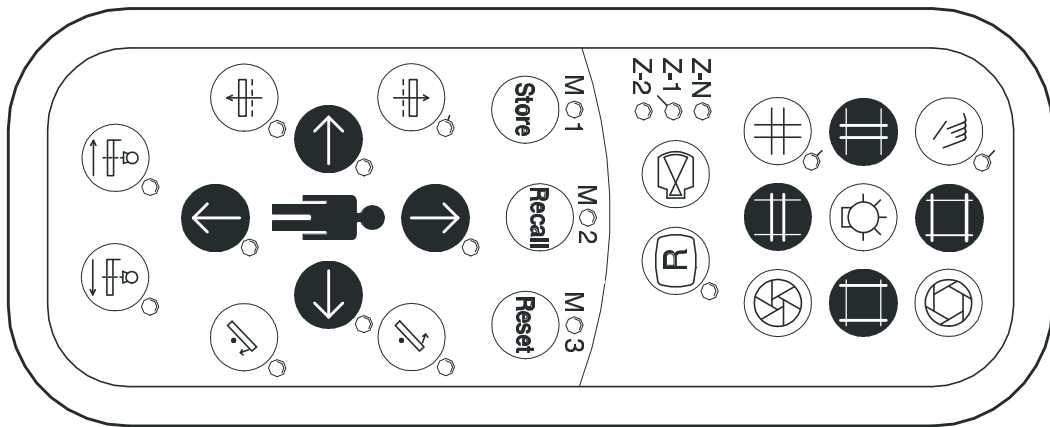

Control Unit

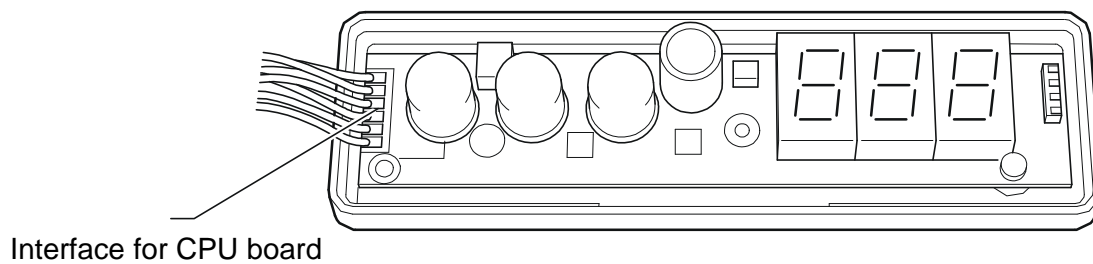

Display Board

2. Installation

2.1 Preparations for Mounting

Prepare the unit location according to the dimensional drawing, Page 6 or 7 or Page 8 or 9.

Caution: The minimum distances listed in the dimensional drawings must be maintained to assure that all movements of the system are possible.

The floor must be capable of bearing a load of 10,450 N on the front mounting points according to Dimensional Drawing, Pages 8 and 9.

The P2 mounting points on the back of the unit must each be capable of assuming 1020 N pull.

Example: Liebig S12/40 or S12/65 expansion bolts with an image quality of 2 with a concrete quality of B 25, DIN 1045. The minimum drill hole depth may be 80 or 105 mm.

With a vinyl tile floor, the floor covering must be cut out in the area of the unit base.

2.2 Unpacking the Unit

Open the crate and remove the protective film (Fig. 01 /Pos. 1). Only open the cartons (Pos. 2,3+4) and place them to one side until it is time to use them.

Check the items included in the shipment or the parts for completeness and for good condition.

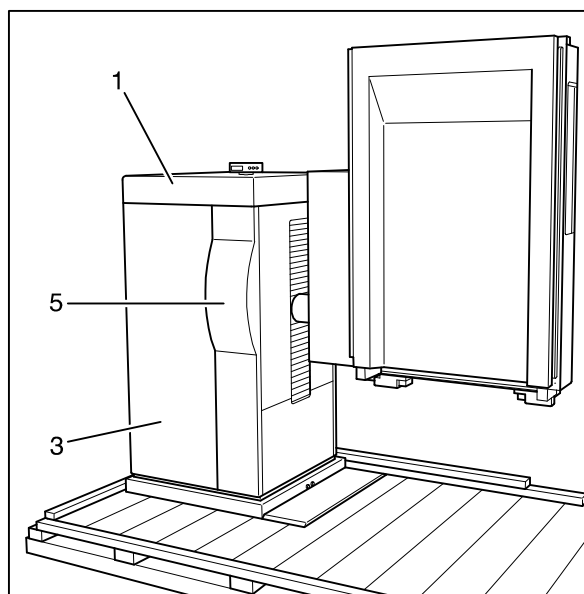
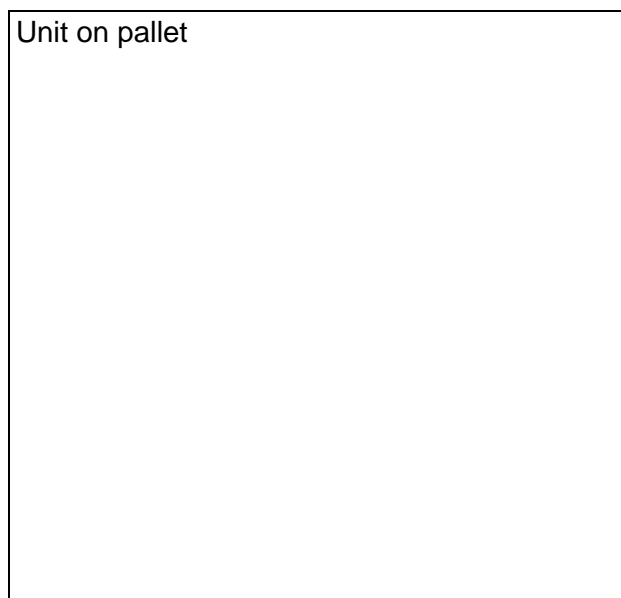

Fig. 01

Fig. 02

Remove the securing screws on the unit base cover panel (Fig. 02/Pos.1). The left cover panel (Fig.03/Pos. 2) and right cover panel (Fig.02/Pos. 3) after removing the mounting screws closest to the floor.

Remove the narrow left (Fig.03/Pos. 4) and narrow right cover panel (Fig.02/Pos. 5).

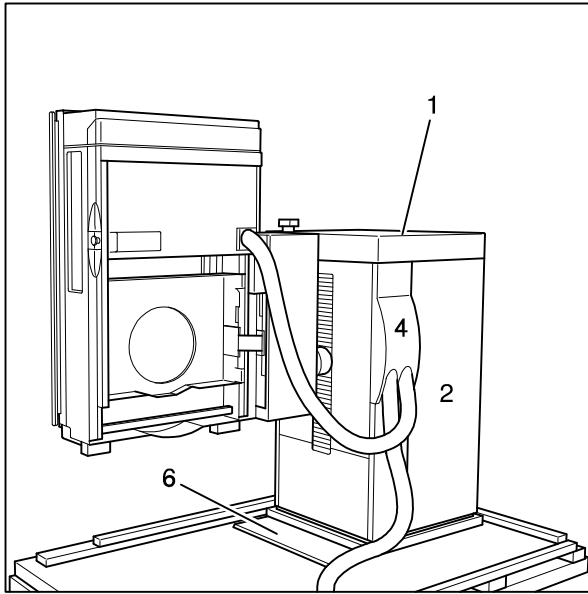

Fig. 03

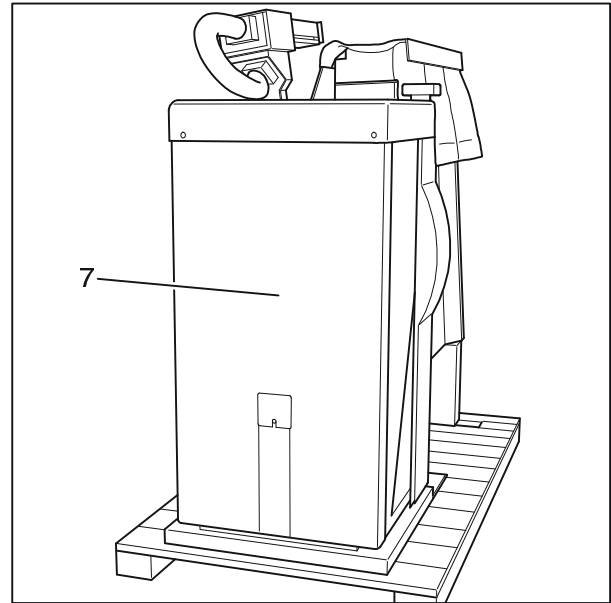

Fig. 04

Take off the back wall (Fig. 04/Pos. 7).

Notice:

The tube unit support arm (Fig. 05/Pos. 1) is hooked onto the opening of the base with the mounting bracket (painted red) (Pos. 2) and secured on the floor plate. The tube unit support arm is unhooked from its holder only after it is installed.

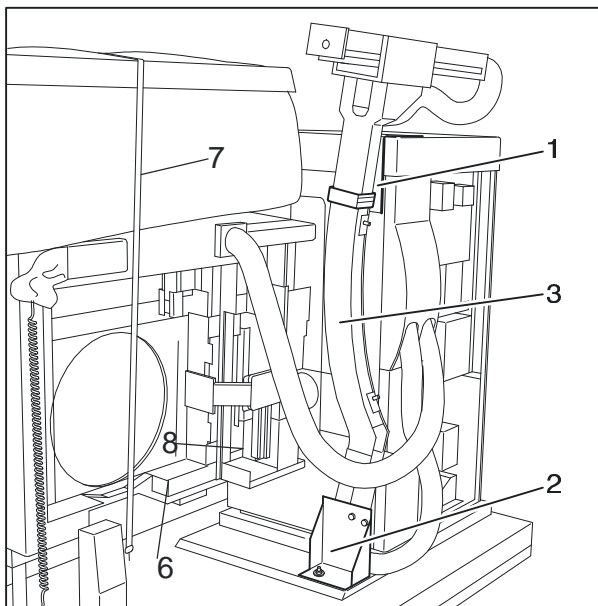

Fig. 05

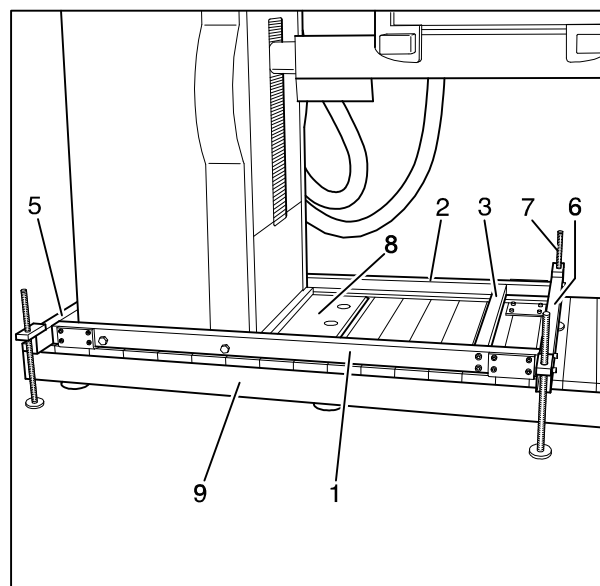

Fig. 06

2.3 Removing the Unit from the Pallet

Remove the transport safety devices (Fig. 05/Pos. 6, 7 + 8).

Install the two support struts of the installation frame (Fig. 06/Pos. 1+2) on both sides of the unit column and the connector piece (Pos. 3) between the two support struts.

Install a spindle cross piece (Pos. 5+6) on each end of both support struts.
 Remove the mounting screws (Fig. 07/Pos. 1+ Fig.06/Pos. 8) of the unit column from the pallet and press it down onto the pallet.
 Use the 4 lift spindles (Fig. 06/Pos. 7) to evenly raise the unit until the transport pallet (Pos.9) is free and then slide it out from under the unit.
 Install the 4 castors (Fig. 08/Pos. 3+4) (transport castors) for transport on the support studs (Pos. 1+2). Use the 4 lift spindles to lower the unit (with narrow transport pathways, remove the spindle cross pieces, Pos. 5+6) and move the unit to its installation location.
 At the installation location, use the spindles to raise the unit until the castors are off the floor. Remove the castors and evenly lower the unit.

Caution:

The two support struts on the installation frame (Fig. 06/Pos. 1+2) may be removed only when the unit is secured to the floor.

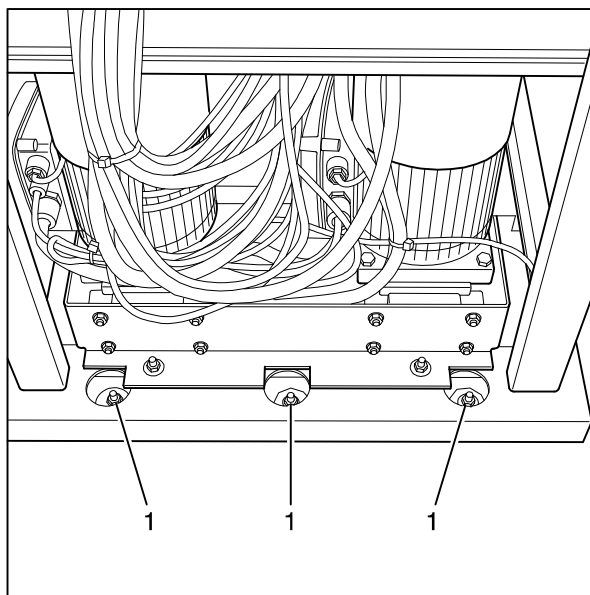

Fig. 07

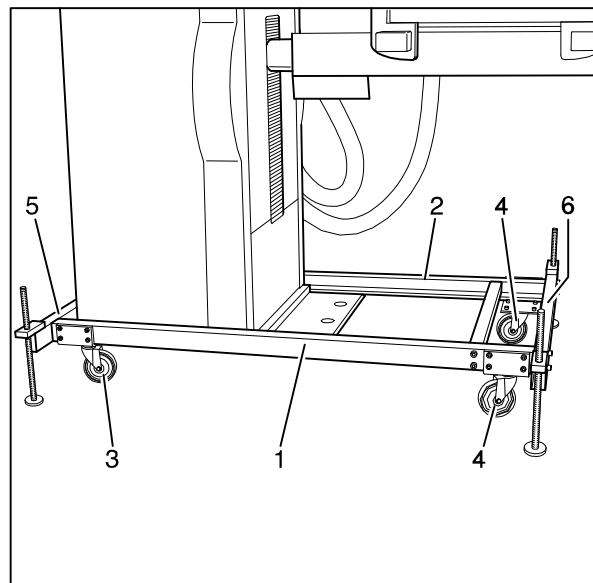

Fig. 08

2.4 Installing the Unit Column

Remove the lower transport bracket (Fig. 05/Pos. 2) on the tube unit support arm.
 While observing the tensile strength data that is listed on them, use the 6 heavy-duty load expansion bolts (for example, Liebig S12/40 or S12/65 expansion bolts) (Fig. 07/Pos. 1 and Fig. 09/Pos. 2).
 Remove the transport frame (Fig. 06/Pos. 1+2).
 Disengage the tube unit support arm (Fig. 03/Pos. 3) towards the top out of the unit base and carefully place it down on the floor next to the unit.
 Disconnect the plug-in connector for the display.
 Remove the cover panel on the unit base (Fig. 02/Pos. 1).

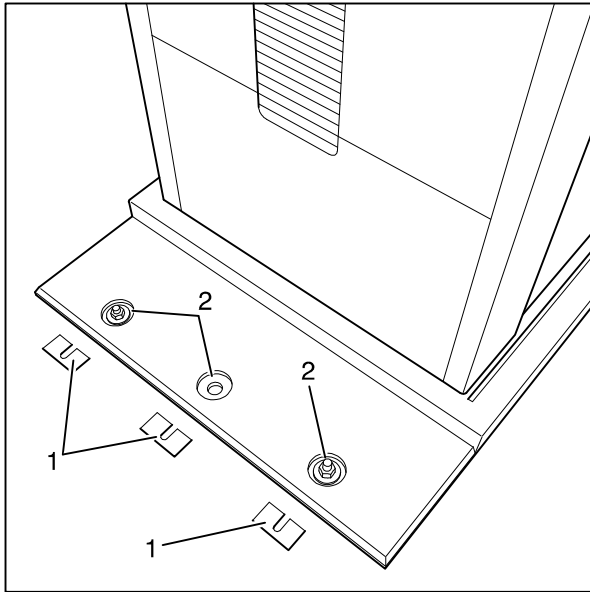

Fig.09

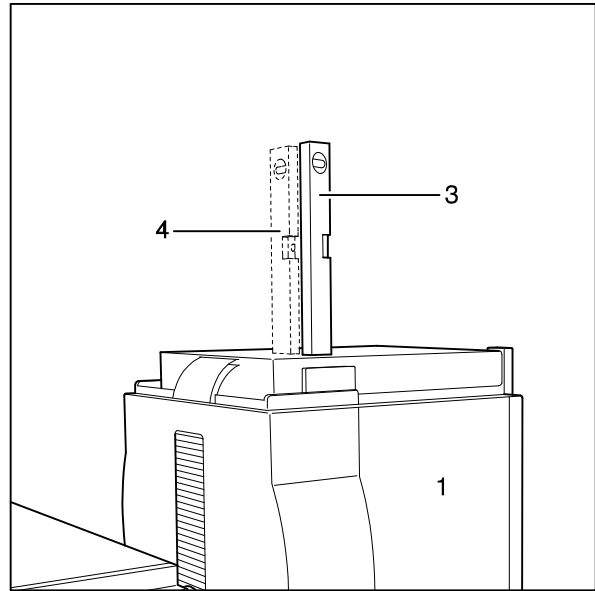

Fig. 10

2.5 Aligning the Unit Column

Check the unit column (Fig. 10/Pos. 1) in both directions using a spirit level that has been placed on the guide rail (Fig. 10/Pos. 3+4).

Compensate for the differences using shims (Fig. 11/Pos. 1+2) from the items included in the shipment.

Caution: The unit column may not be under tension in any direction.

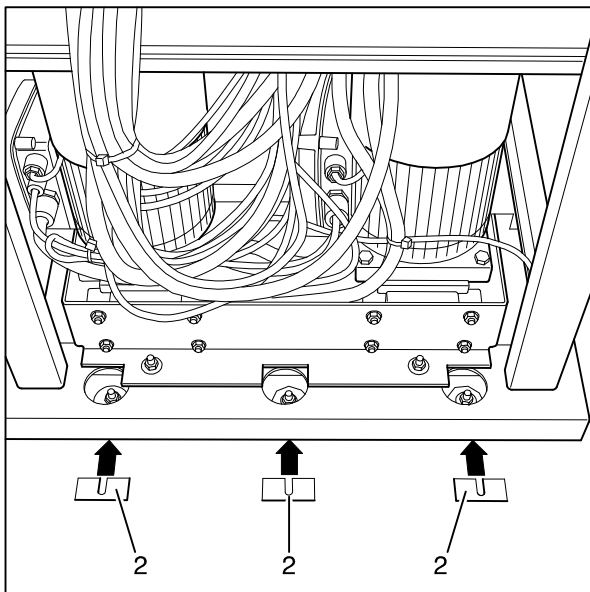

Fig. 11

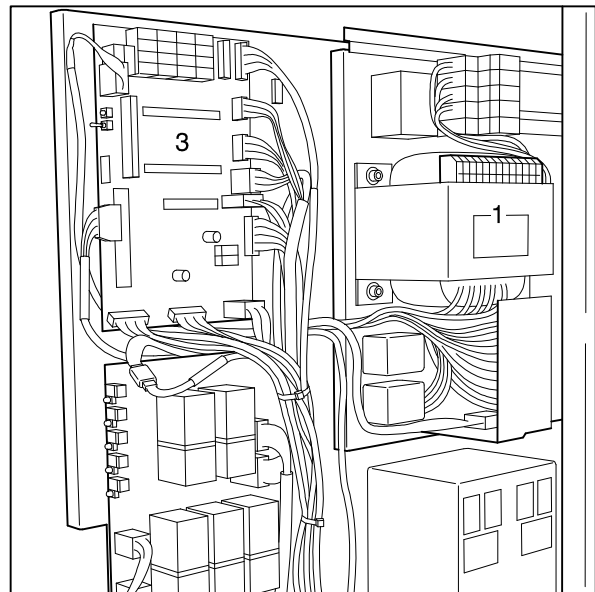

Fig. 12

2.6 Temporarily Connecting Line Power

Caution:

If the unit is connected to a different line power than that listed on the order, the setting must be changed to the one that corresponds to the local line power **as specified by the Wiring Diagram** to the power line transformer (Fig. 12/Pos. 1).

Provide the unit with power by connecting a temporary connection cable (plug-in cable) to move the table for individual installation steps.

Connect the multi-function footswitch on the bottom of the table.

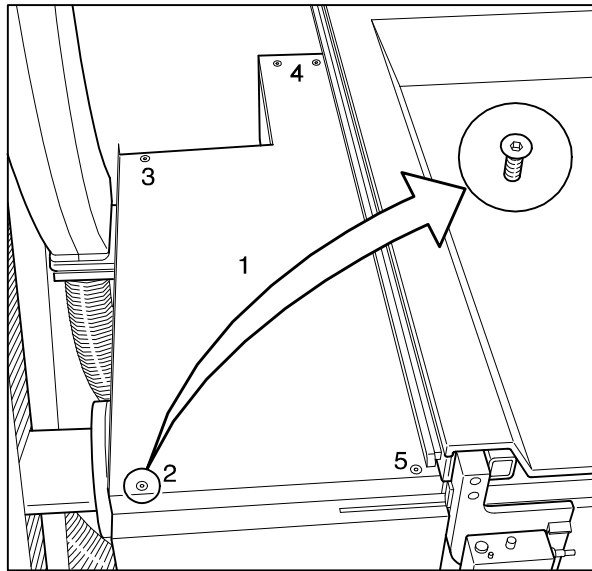

Fig. 13

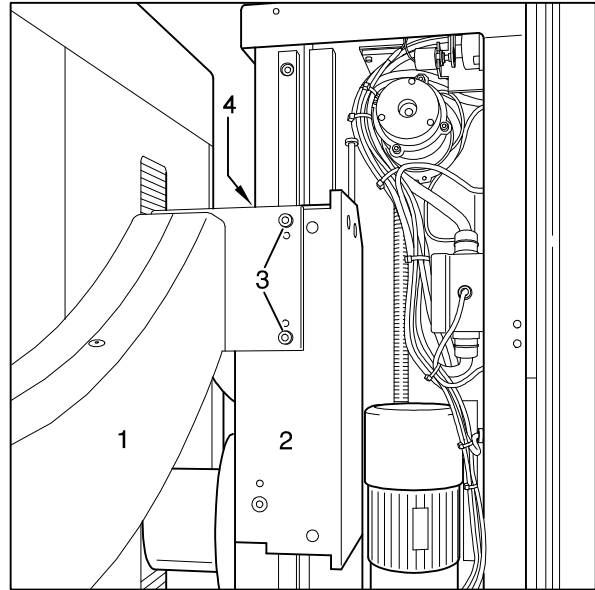

Fig. 14

2.7 Installing the Tube Unit Support Arm

Tilt the tabletop all the way down into the horizontal position and move it towards the front, transversely to the user, until it is in the end position. Move the tube unit carriage (system carriage) max. to the head end.

Remove the drain panel (Fig. 13/Pos. 1) after loosening the 5 mounting screws (Pos. 2,3+4). Place the tube unit support arm (Fig. 14/Pos. 1) on the longitudinal carriage (Pos. 2) and secure it in place with the 6 screws (Pos. 3+4).

Remove the red transport bracket (Fig. 05/Pos. 1) (hooking device).

Reinstall the drain panel (Fig. 13/Pos. 1).

2.8 Preinstalling the Tube Unit – Collimator Combination

Assemble the tube unit – Collimator combination according to the description in the manufacturer's installation instructions. See Fig. 15

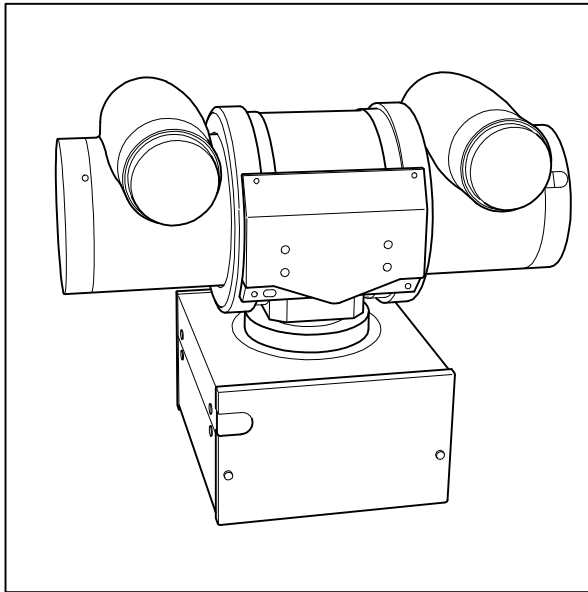

Fig. 15

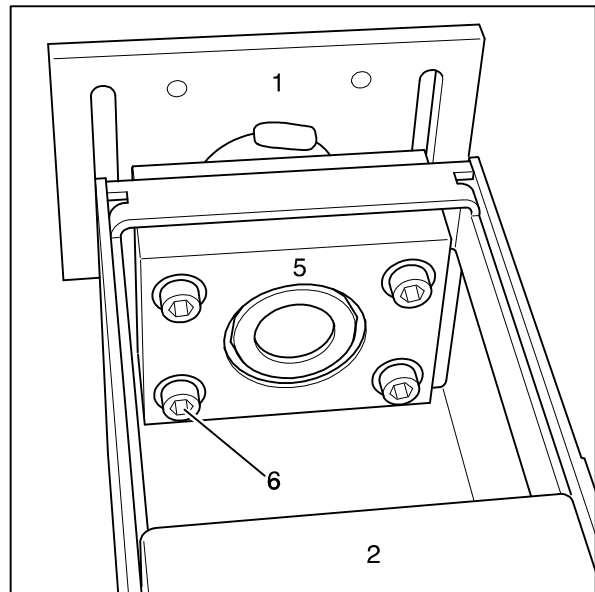

Fig. 16

2.9 Installing the Tube Unit – Collimator on the Tube Unit Support Arm

Tilt the tabletop until it is vertical and move the tube unit carriage towards the foot-end. Remove the cover (Fig. 18/Pos. 6) on the tube unit support arm. Remove the support studs (Fig. 16/Pos. 1) from the tube unit support arm (Pos. 2). Place the preinstalled tube unit – collimator combination (Fig. 17/Pos. 1) down on its side and move the command arm (Pos. 2) between the support studs (Pos. 3) and the tube unit housing (Pos. 1) and secure them in place with the 4 screws (Pos. 5).

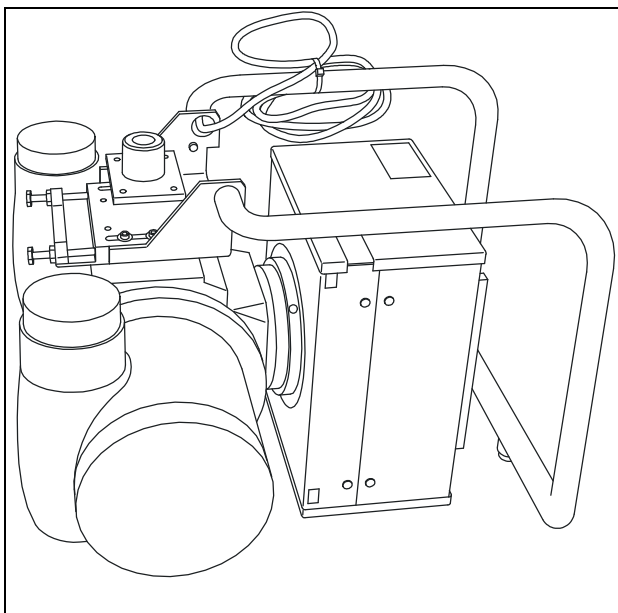

Fig. 17

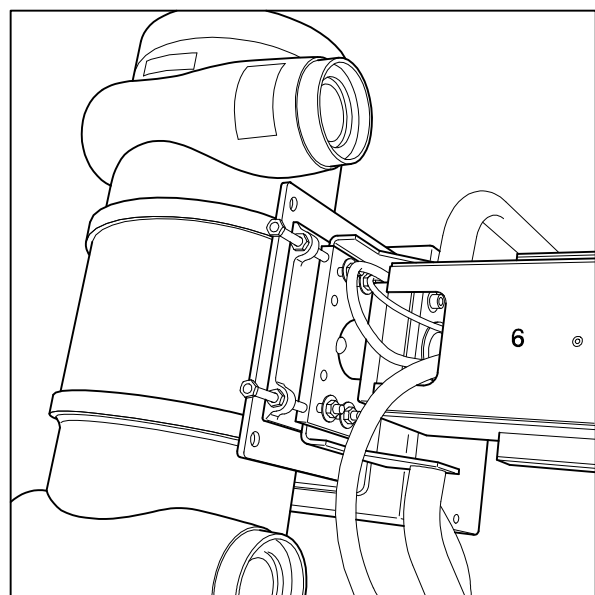

Fig. 18

Place the assembled tube unit – collimator combination (Fig. 17/Pos. 1) on the tube unit support arm (Fig. 18/Pos. 2) using the support studs (Pos. 3), insert the shims (Fig. 16/ Pos. 5) and secure it in place using the 4 screws (Pos. 6).

2.10 Installing the Image Intensifier

Remove the I.I. adapter plate (Fig. 20/Pos. 1) from the I.I. carriage (Pos. 2). Secure the I.I. adapter plate (Fig. 19/Pos. 1) in position on the I.I. housing (Pos. 2) with the screws. Install the I.I. unit on the I.I. carriage (Fig. 20/Pos. 2) using the two strips (Pos. 4+5) the 8 washers and the 8 nuts (Pos. 7). Max. torque: 20 Nm.

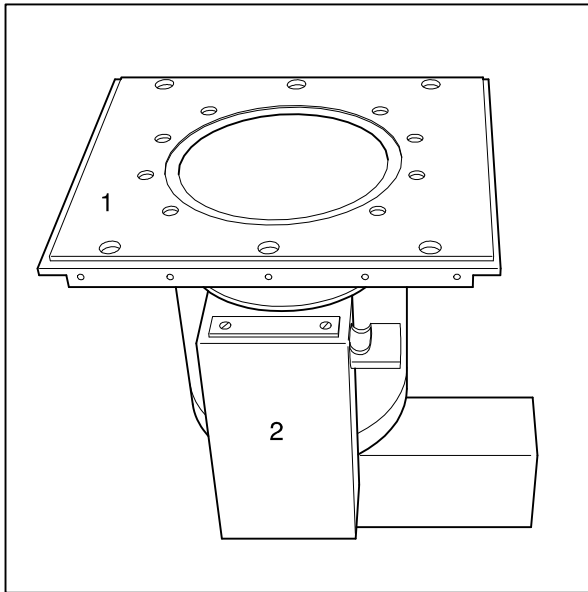

Fig. 19

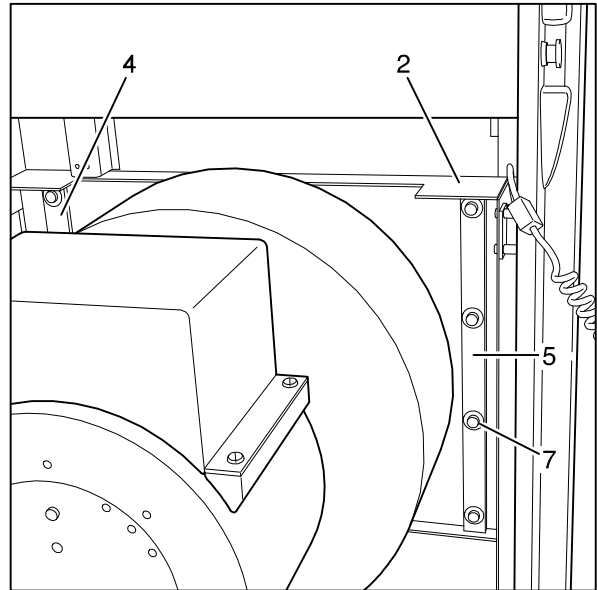

Fig. 20

2.11 Laying the Collimator Cables

The cable for the collimator is laid in the unit base parallel to the high voltage cables. The cable for the collimator is laid parallel from the unit controller in the unit base to the high voltage cables.

Clamp, or plug in, the cable (Fig. 12/Pos. 2) on the unit controller (Pos. 3), at the connection points provided.

Lay the cables later in Section 2.12, Section 2.12.

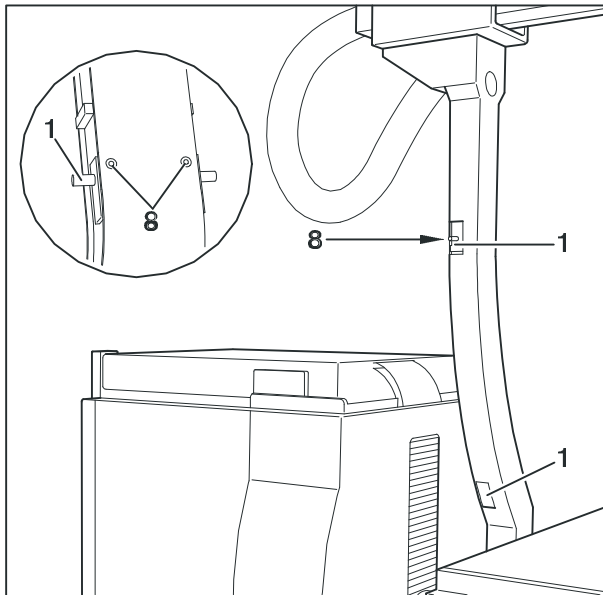

Fig.21

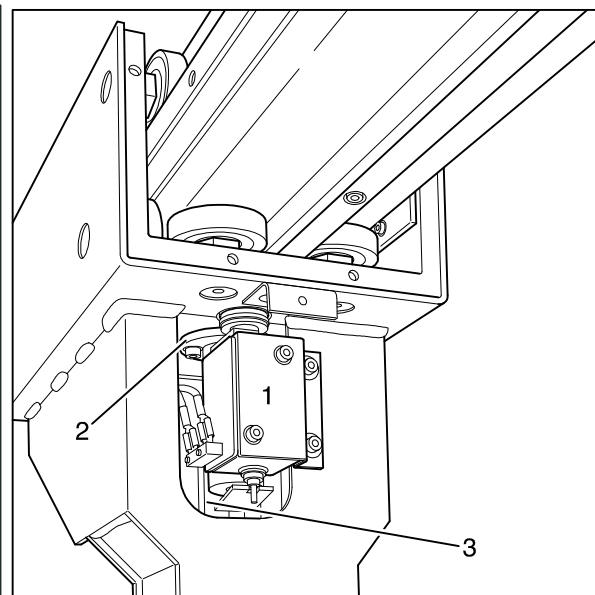

Fig. 22

2.12 Laying the High Voltage Cables

Preparations:

Remove the cover (Fig. 18/Pos. 6), the flexible hose holder (Fig. 23/Pos. 1), the flexible hose mount (Pos. 3) and the flexible hose holder (Pos. 5).

Remove the lift magnet (Fig. 22/Pos. 1), the latching stud (Pos. 2) and the cable deflector (Pos. 3).

Take the two safety limit switches (Fig. 21/Pos. 1+2) out of the tube unit support arm after removing the screws (Pos. 8).

Lay the high voltage cables and the stator cable coming from the generator up to the wall or to the floor outlet.

To lay cables in the unit, 7 meters are required.

The high voltage cable coming from the wall and the stator cable must first be laid through the flexible hose (Fig. 23/Pos. 9), through the back wall (Pos. 10), or if it is coming directly from the floor, then lay it directly to the cable channel (Pos. 11) and up into the unit base.

Lay the cable for the collimator, the high voltage cable and the stator cable parallel to the cables for the unit controller to the cable outlet (to the side of the unit table) (Fig. 23/Pos. 14).

Gather the cables together so that they are slightly staggered, pass them through the flexible hose (Pos. 16) while being careful of the flexible hose mounting, and then pull them through the hose mounting and through the support arm (Pos. 17), in the direction of the tube unit (Pos. 20).

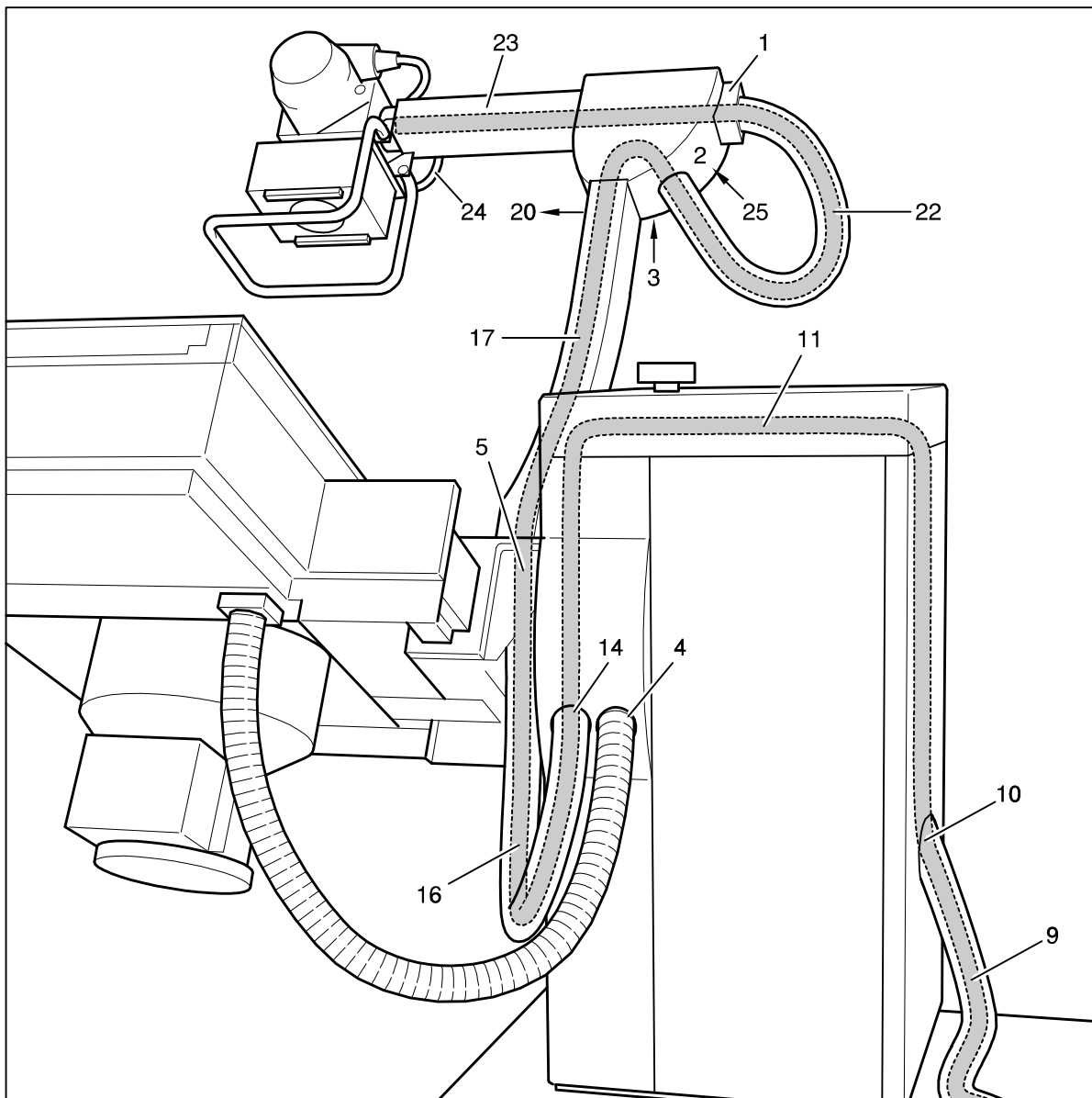

Fig. 23

Lay the cables through the support arm towards the back, through the flexible hose (Pos. 22) and through the carriage (Pos. 23) to the tube and to the collimator.

Guide the cable for the control handle (Pos. 24) to the connector strip (Pos. 25) in the support arm and clamp it in place.

Secure the cables in place with the cable ties provided.

Reinstall the cable deflector (Fig. 22/Pos. 1) the latching studs (Pos. 2) and reinstall the lift magnet (Pos. 3).

Reinstall the two safety switches (Fig. 21/Pos. 1+2) for the tube unit support arm and secure them in place with the screws (Pos. 8).

Reinstall the flexible hose holder (Fig. 23/Pos. 1), the flexible hose mount (Pos. 3) and the flexible hose holder (Pos. 5). Reinstall the cover panel (Fig. 18/Pos. 6).

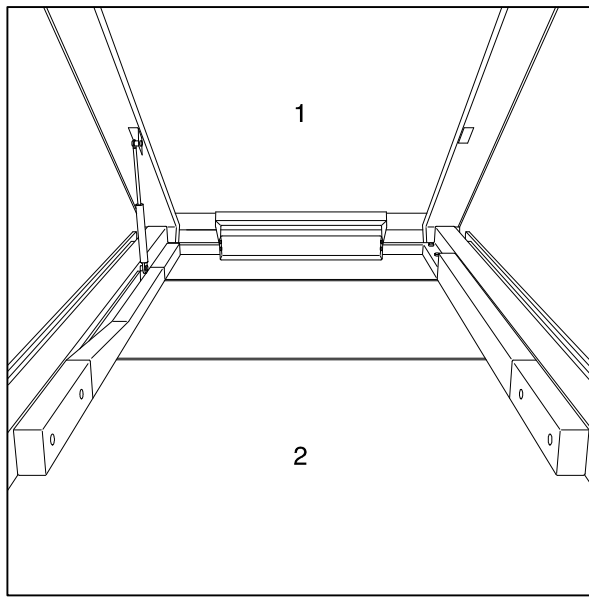

Fig.25

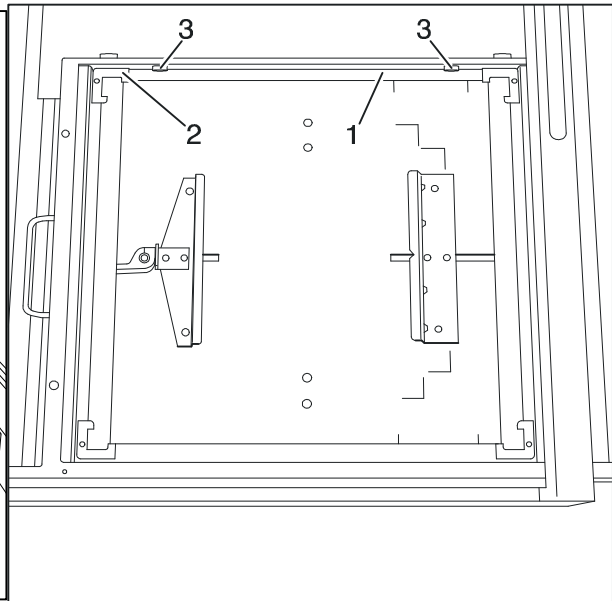

Fig. 26

2.13 Laying the I.I. Cable

First lay the I.I. cable coming from the wall through the flexible hose (Fig. 23/ Pos. 9), through the back wall (Pos. 10) and then – if it is coming directly through the floor – to the cable channel (Fig. 23/Pos. 11) and up into the unit base.

Lay the I.I. cable parallel to the cables for the unit controller to the cable outlet (on the side of the unit base) (Fig. 25/Pos. 4).

Remove the flexible hose (Fig. 26/Pos. 1). Pull the I.I. cable through the flexible hose to the table, place it in the flexible plastic link chain (Pos. 2) and lay it to the I.I. connector (Pos. 3).

2.14 Making the Power Connection through the Generator

Remove the temporary power connection and connect the power via the generator.

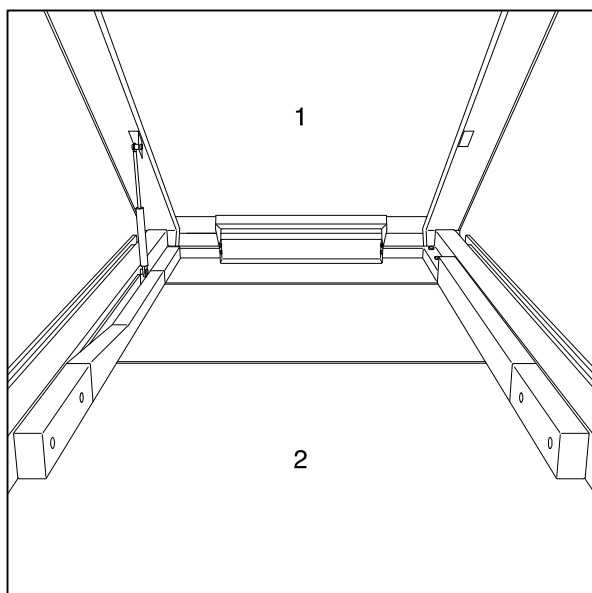

Fig. 27

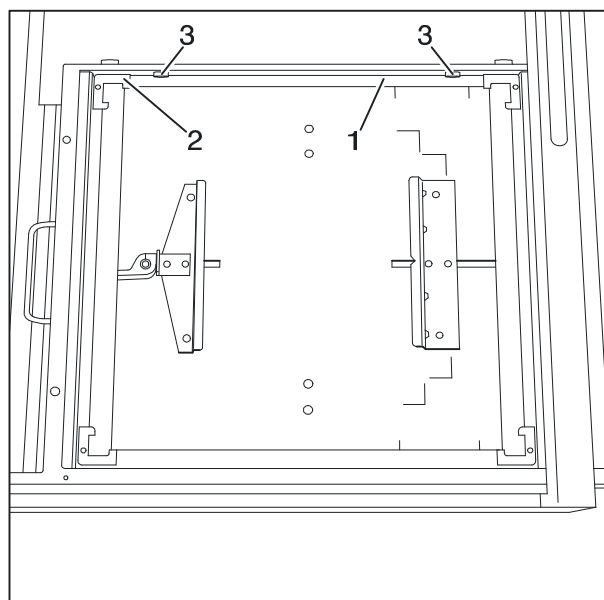

Fig. 28

2.15 Installing the Measuring Chamber

Lift up the tabletop (CFC panel) (Fig. 27/Pos. 1), it will be held by the gas spring. Move the tabletop towards the back and remove the front Nirosta panel. Move the tabletop towards the front and remove the rear Nirosta panel. Remove the left (Fig. 27/Pos. 3) and right (Pos. 4) cover panels. Remove the screws for the spiral cable guide panel and remove the cable guide panel. Move the tabletop longitudinally, remove the 6 mounting screws in the polycarbonate panel (Pos. 2) and remove the polycarbonate panel towards the front.

Switch the unit into the service mode, the green LED on the controller goes on and stays on. Press the Store and Reset buttons on the control unit simultaneously, the three memory LED's on the control unit will blink green and the LED on the controller will blink very rapidly.

The cassette Bucky can be moved slowly forward and backward using the Recall and Reset buttons.

Move the Bucky into the exposure position using the Recall button. Remove the grid frame (Fig. 28/Pos. 1) after removing the two screws (Pos. 3). Insert the measuring chamber into the holder (take note of the measuring chamber orientation) and secure it in place.

First lay the measuring chamber cable coming out of the wall through the corrugated hose (Fig. 23/ Pos. 9), through the back wall (Pos. 10), or the cable coming directly out of the floor, to the cable channel (Pos. 11) up and into the unit base.

Lay the measuring chamber cable parallel to the cables for the unit controller to the cable outlet (on the side of the unit base) (Fig. 25/Pos. 4).

Remove the corrugated hose holder (Fig. 26/Pos. 1). Pull the measuring chamber cable through the corrugated hose to the table. Insert the measuring chamber cable through the side frame box into the flexible plastic chain of the Bucky and bring it to the measuring chamber connector.

Caution:

The cable must be laid so that the cassette drive belt does not touch the cable.

Then reinstall the grid frame. Reinstall the polycarbonate panel (Pos. 2).

2.16 Installing the Grid – Replacing the Grid

Lift up the tabletop (CFC panel) (Fig. 27/Pos. 1), it will be held by the gas spring. Move the tabletop towards the back and remove the front Nirosta panel. Move the tabletop towards the front and remove the rear Nirosta panel. Remove the left (Fig. 27/Pos. 3) and right (Pos. 4) cover panels. Remove the screws for the spiral cable guide panel and remove the cable guide panel. Move the tabletop longitudinally, remove the 6 mounting screws in the polycarbonate panel (Pos. 2) and remove the polycarbonate panel towards the front.

Switch the unit to the service mode, the green LED on the controller will go on and stay on. Press the Store and Reset buttons on the controller simultaneously, the three memory LED's on the controller will blink green and the LED on the controller will blink very rapidly.

The cassette Bucky can now be moved slowly forward and backward using the Recall and Reset buttons.

Move the Bucky into the exposure position using the Recall button. Remove the mounting brackets (Fig. 28/ Pos. 2). Insert the grid with the focus mark facing up and secure it in place with the mounting brackets. Reinstall the polycarbonate panel (Fig. 27Pos. 2).

2.17 Installing the Tilt Angle Display- Error Display

Place the unit base cover panel (Fig. 29/Pos. 1) on the unit base. Guide the cable (Pos. 2) into the conduit (Pos. 3), install the tilt angle display (Pos. 4) and plug in the connector. Secure the plug-in connector with cable ties.

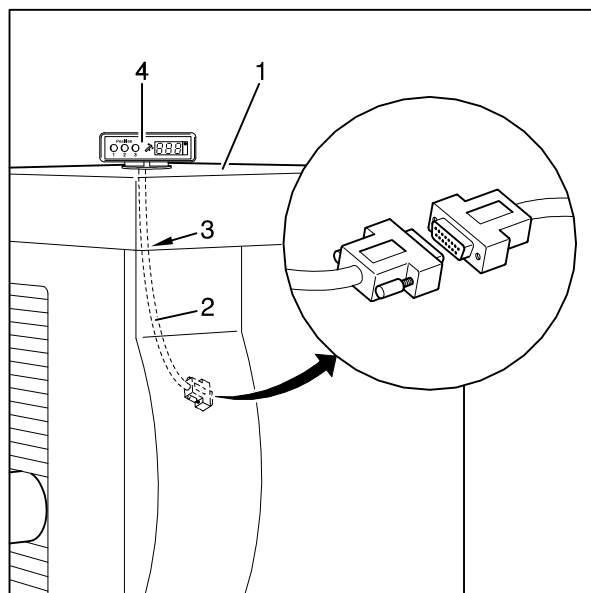

Fig. 29

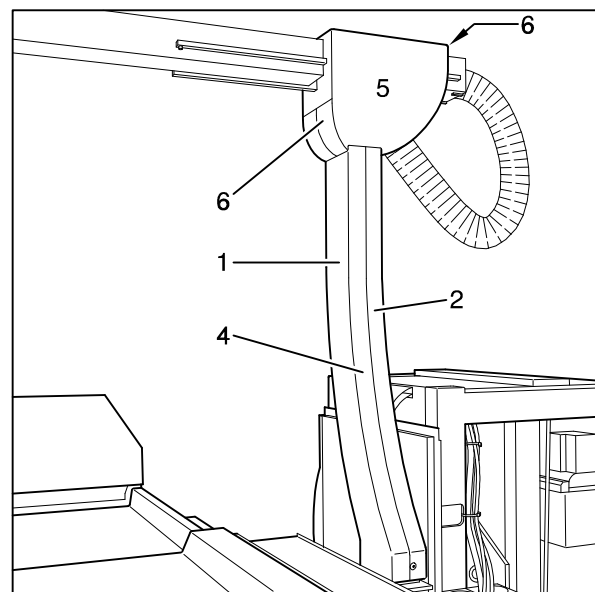

Fig. 30

2. 18 Installing the Cover Panels

Caution: Before the cover panels are installed, it is best to carry out the adjustment as described in Section 3.

Tube unit support arm:

Place the two halves of the cover panel (Fig. 30/Pos. 1) over the support arm (Pos. 2) while paying attention to the two safety switches (Fig. 21/Pos. 1+2) and secure them in place with the roll pins (Pos. 4). Place the two head cover panels (Pos. 5) over the support arm and secure them in place with the paneling screws (Pos. 6).

Unit base:

Reinstall the narrow left (Fig. 31/Pos. 4) and the narrow right cover panel (Pos. 5).

Reinstall the unit base cover panel (Fig. 29/Pos.1), the left (Pos. 2) and right cover panels (Pos. 3).

Reinstall the cover panel bracket for the floor panel (Pos. 6) and the back wall (Pos. 7).

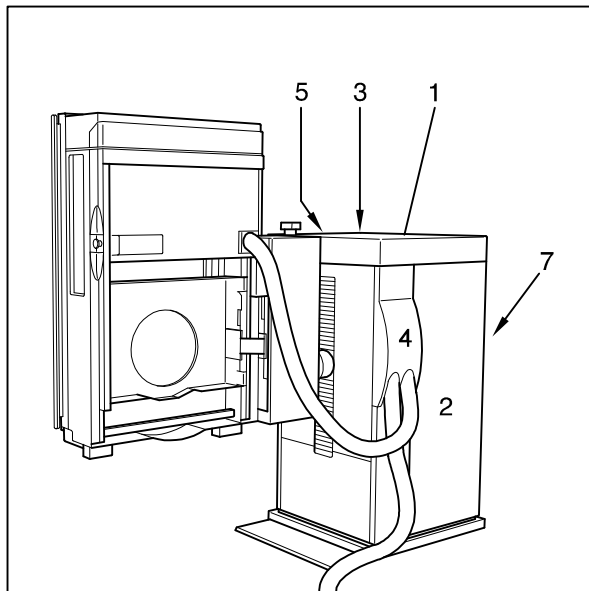

Fig. 31

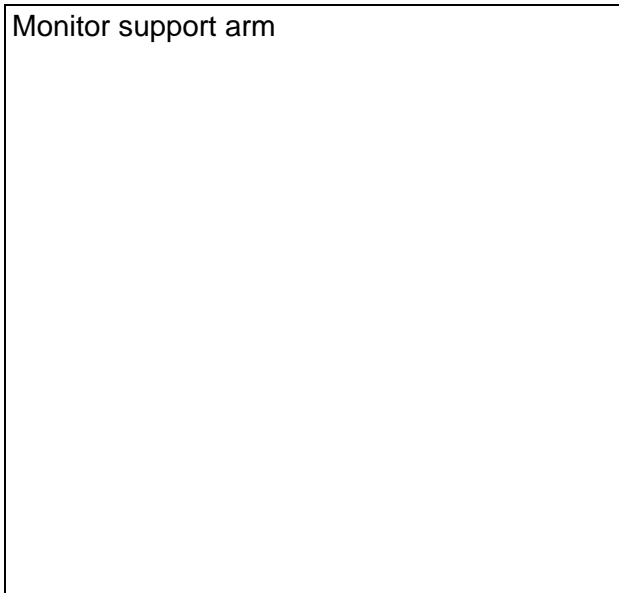

Fig. 32

2.19 Installing the Monitor Support Arm (Option)

Insert the monitor support arm (Fig. 32/Pos. 1) into the tube (Pos. 3).

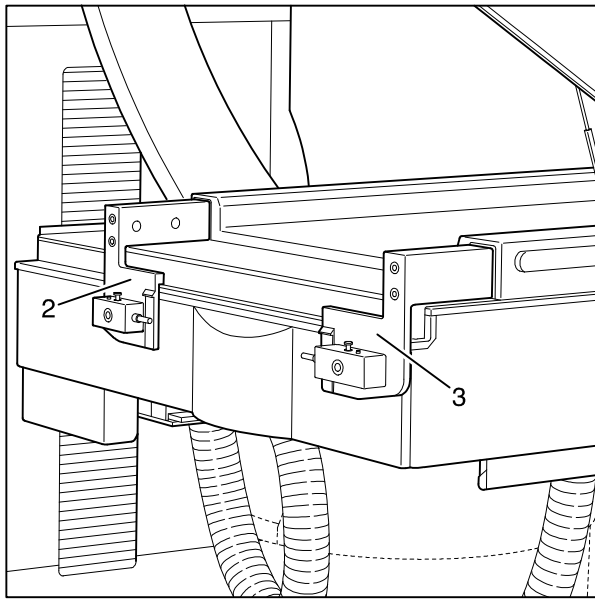

Fig. 33

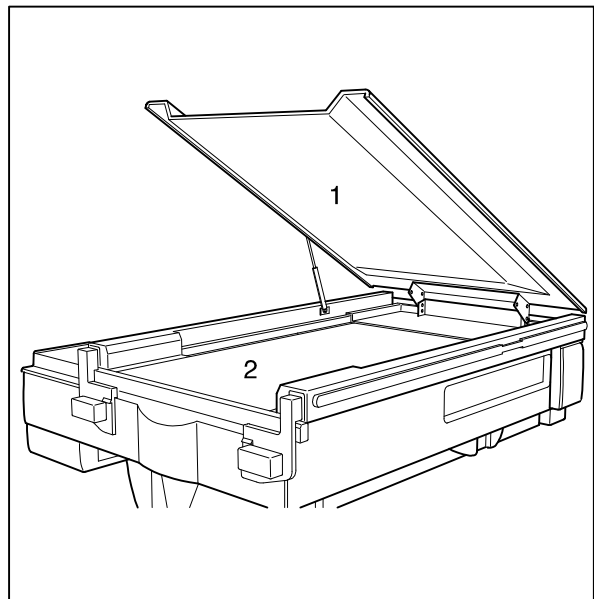

Fig. 34

2.20 Installing the Mount for the Flush Bowl

Lift up the tabletop (CFC panel) (Fig. 34/Pos. 1), it will be held in place by the gas spring. Remove the two covers on the tube frame. Insert the left and right mounts (Fig. 33/ Pos. 2+3) into the opening of the tube frame and secure them with 2 screws for each.

2.21 Sealing the Table Frame Cover Panel

Seal the table frame cover panel (Fig. 34/Pos. 2) along the table frame using the Sista F 101 sanitary caulking.

3. Adjustment

Caution: If changes are made to the movement paths, the software must afterward be corrected.

3.1 Tube Unit Support Arm

Check the tube unit support arm (Fig. 51/Pos. 1) with the spirit level (Pos. 2) and loosen the nuts (Fig. 51a/Pos. 5) and the mounting screws (Fig. 51b/Pos. 6). Correct any differences with the screws (Pos. 8). Retighten the mounting screws and nuts.

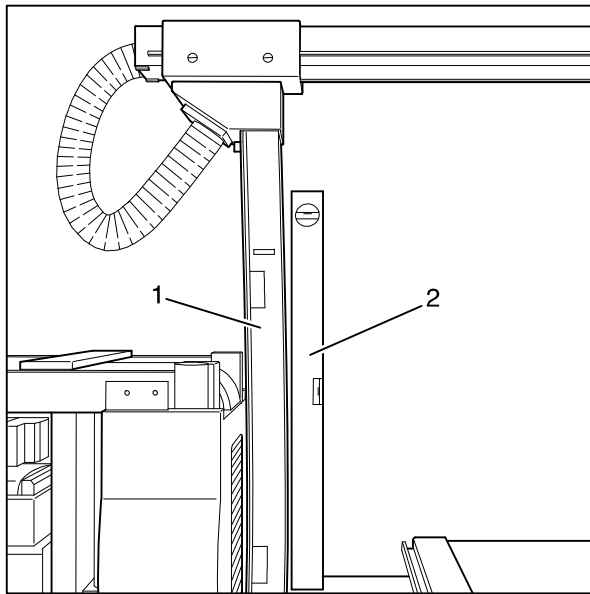

Fig.51

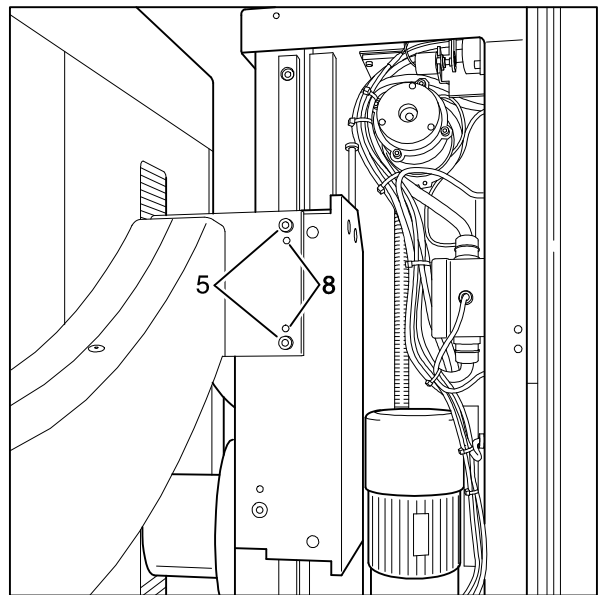

Fig.51a

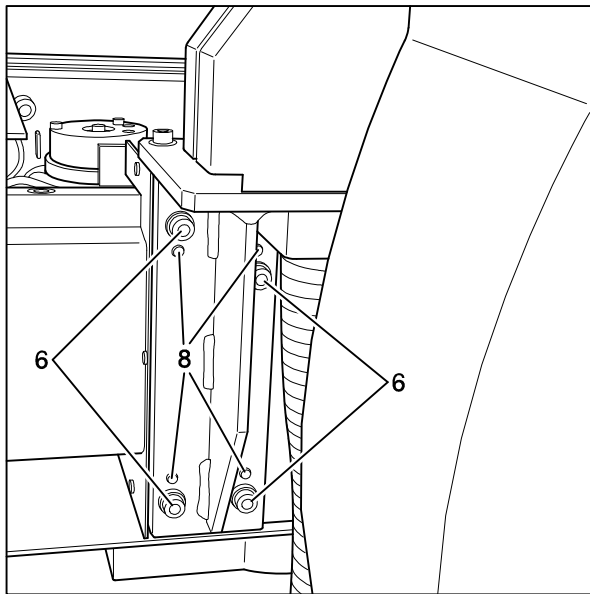

Fig.51b

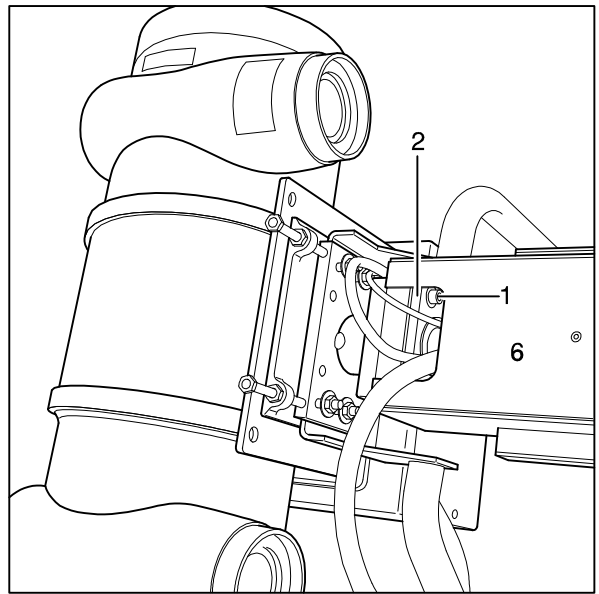

Fig.52

3.2 Central Beam - Center of Bucky

Determine the deviation of the central beam.

Transverse to the tabletop, for this:

Caution:

Risk of an accident exists here because the tube unit must be loosened.

Remove the cover panel (Fig. 52/Pos. 6). Remove the mounting screws (Fig. 52/Pos. 1), remove the shims (Pos. 2) for the tube unit and insert them to compensate for any difference in the central beam. Reinstall the mounting screws (Pos. 1).

Lengthwise to the tabletop, for this:

Remove the cover panel (Fig. 53/Pos. 1). Correct the exposure position of the system using the software and the switch strike plate (Fig. 54/ Pos. 2) by the amount of the difference. Reinstall the cover panel (Fig. 53/Pos. 1).

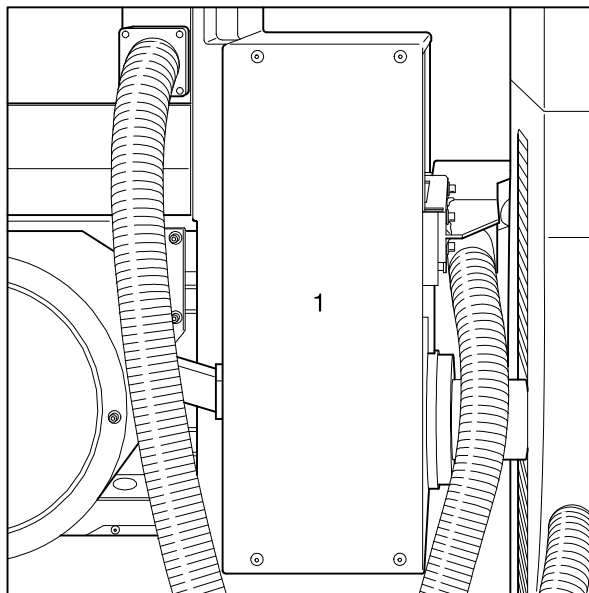

Fig.53

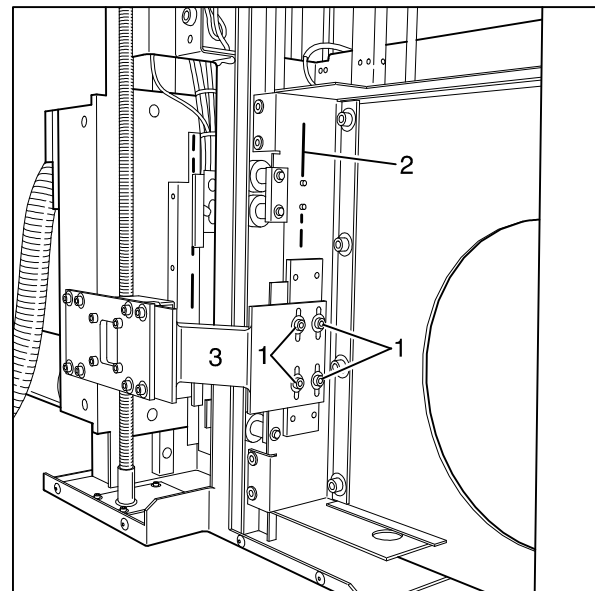

Fig.54

3.3 Central Beam – Center of I.I.

Determine the deviation of the central beam.

Loosen the screws (Fig. 54/Pos. 1), correct the connector brackets (Pos. 3) by the amount of the difference and retighten the screws.

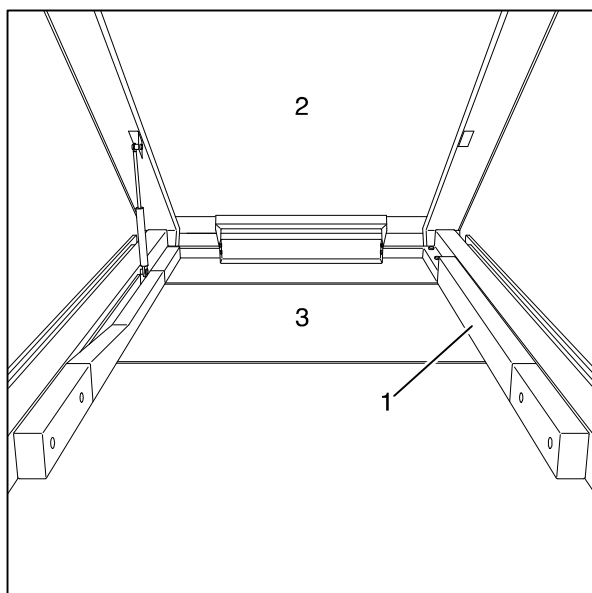

Fig.55

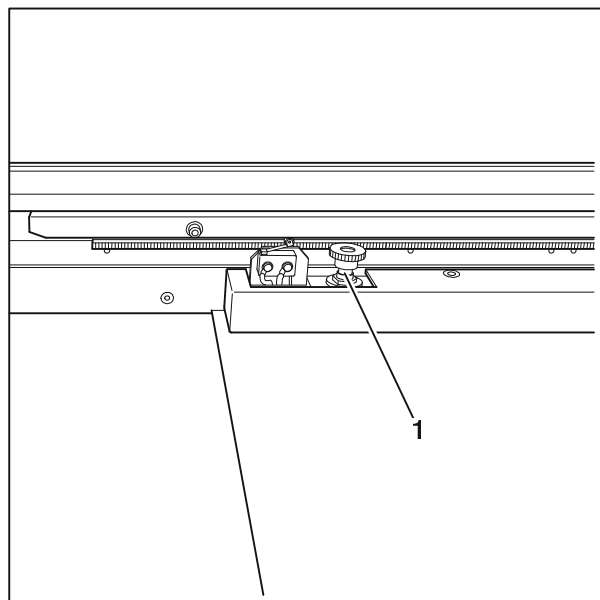

Fig.56

3.4 Movement Path Potentiometer, Tabletop longitudinal

Lift up the tabletop (Fig. 55/Pos. 2) (it will be held in place by the gas spring) and remove the cover panel (Fig. 55/Pos. 1). Move potentiometer =AU -R4 (Fig. 56/Pos. 1) away from the pinion rack, move the tabletop into the centered position. Turn the potentiometer to the middle position, mesh it back into the pinion rack and align the pinion on the rack. Check the function over the entire movement path and reinstall the cover panel.

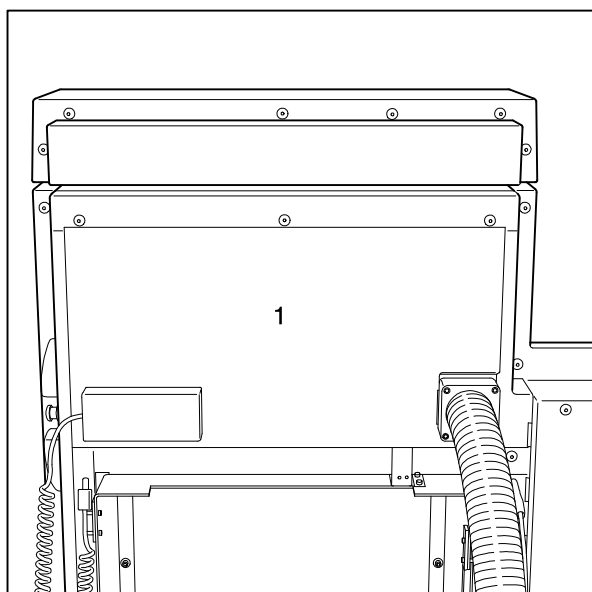

Fig.57

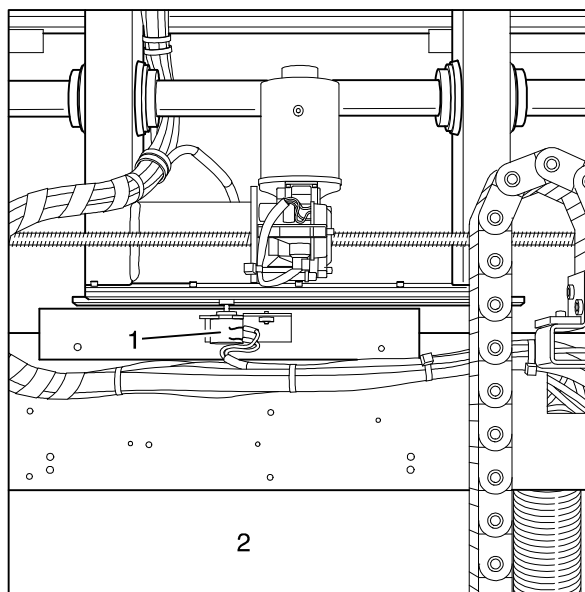

Fig.58

3.5 Movement Path Potentiometer, Tabletop transverse

Remove the cover panel (Fig. 57/Pos. 1). Move the tabletop transversely into the centered position, lift up potentiometer =AU -R6 (Fig. 58/Pos. 1) (*the view in Fig. 58 is visible only when the cover is removed Fig. 55/Pos. 3, however, the potentiometer can be reached from behind through the slot Pos.2*) and set it to the middle position. Mesh the pinion and align it to the rack. Move through the entire movement path and while doing this, check the function.

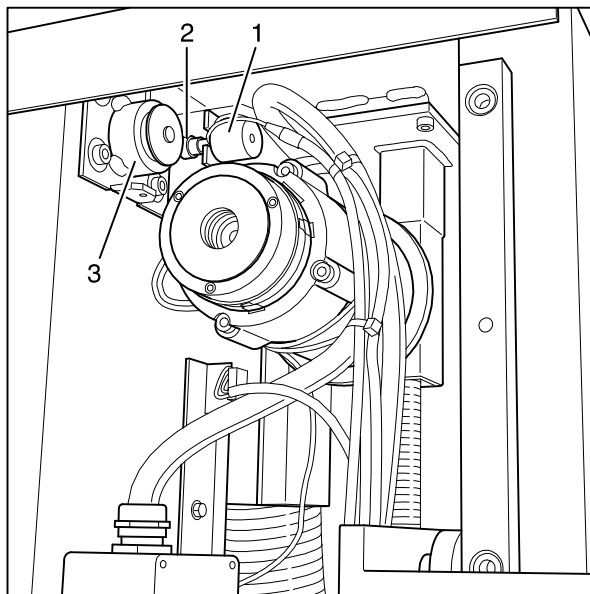

Fig.59

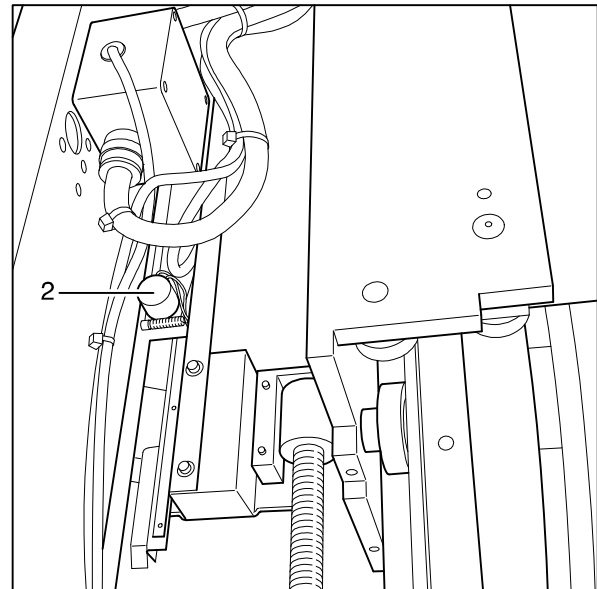

Fig.60

3.6 Bucky - Cassette Tray Movement Path Potentiometer

Move the cassette carriage into the park position and turn the potentiometer =AU -R5 (Fig. 59/Pos. 1) until it is one half turn before the mechanical end position, while doing this, take note of the direction of the turn. Adjust the potentiometer pinion (Pos. 2) to the opposing pinion (Pos. 3).

3.7 I.I. Carriage System Potentiometer

Move the support arm until it is at the mechanical end stop at the foot end. Turn the potentiometer =AU -R2 (Fig. 60/Pos. 2) until it is half a turn in front of the mechanical end position; while doing this, take note of the direction of the turn.

Move the system toward the head end until it is 7 mm in front of the stop and save the software limit for the head-end limit position.

Move the system toward the head end until it is 7 mm in front of the stop and save the software limit for the foot-end limit position.

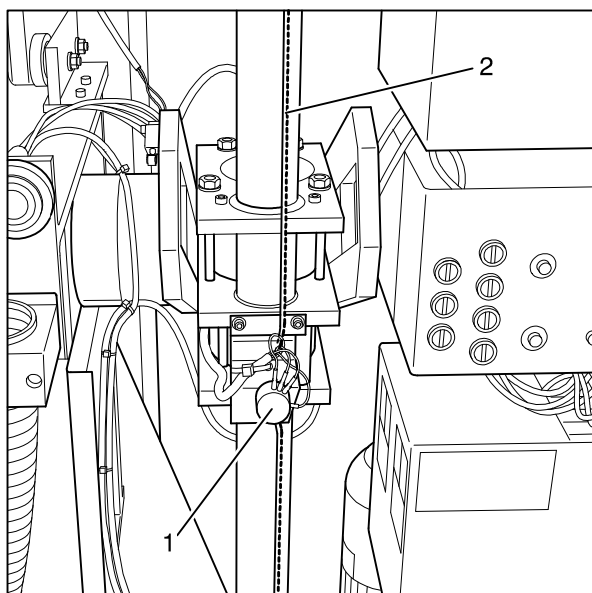

Fig.61

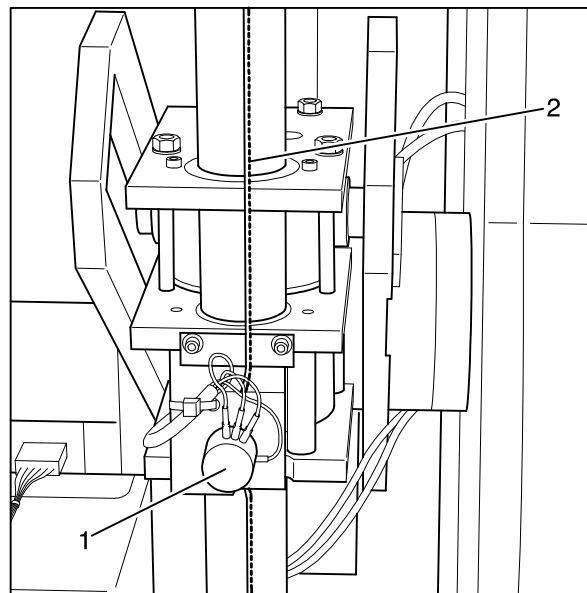

Fig.62

3.8 Potentiometer 1 – Table Tilt Movement Path

Take off the potentiometer belt (Fig. 61/Pos. 2). Move the vertical carriage into the top position and tilt the tabletop so that the potentiometer moves into the highest possible position, e.g. -20° position. Turn potentiometer =AU -R1 (Pos. 1) until it is half a turn in front of the mechanical end position; while doing this, take note of the direction of the turn. Place the potentiometer belt back on without turning the potentiometer and secure it in position.

3.9 Potentiometer 2 – Table Tilt Movement Path

Take off the potentiometer belt (Fig. 62/Pos. 2). Move the vertical carriage into the top position and tilt the tabletop so that potentiometer =AU -R3 (Pos. 1) moves into the highest possible position, e.g. $+88^\circ$ position. Turn the potentiometer until it is half a turn in front of the mechanical end position; while doing this, take note of the direction of the turn. Place the potentiometer belt back on without turning the potentiometer and secure it in position.

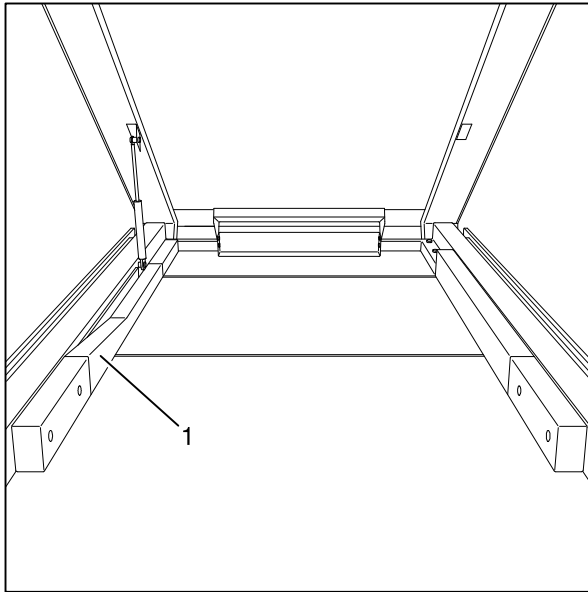

Fig.63

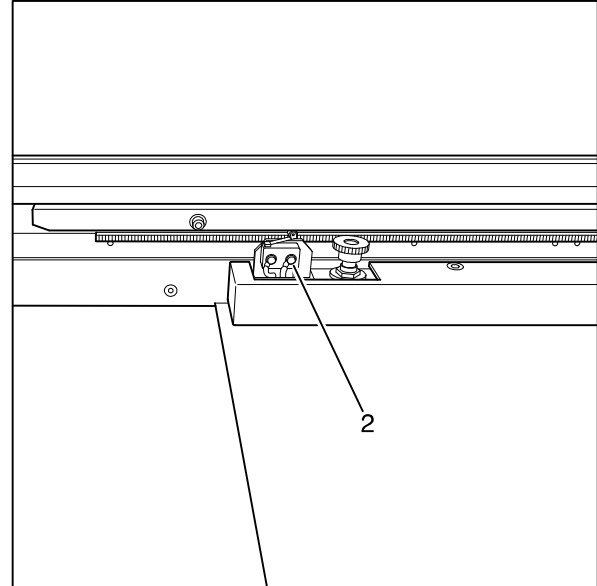

Fig.64

3.10 Tabletop Longitudinal Safety Switch

Lift up the tabletop (it will be held in place by the gas spring) and remove the cover panel (Fig. 63/Pos. 1). Set the software end positions to $240_{\pm 5}$ mm in each direction. Adjust the limit switch (Fig. 64/Pos. 2) so that it switches off approx. 3 - 5 mm behind each end position. To do this, either the limit switch or the switch strike place can be adjusted. Check the function over the entire movement path and reinstall the cover panel.

3.11 Tabletop Transverse Safety Switch

not configured

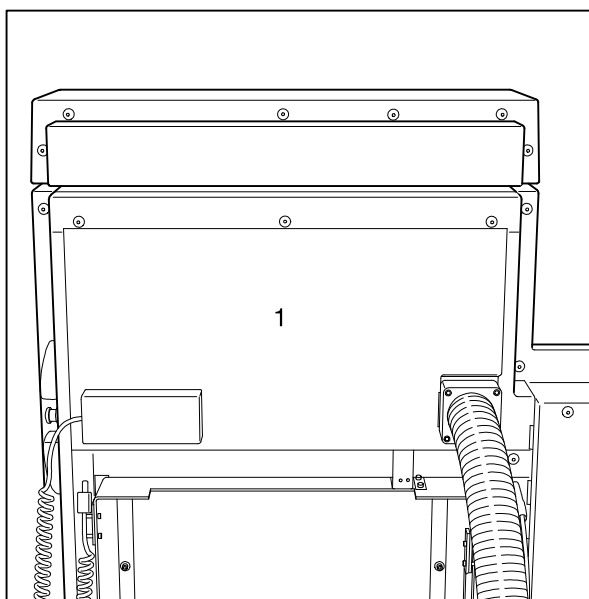

Fig.65

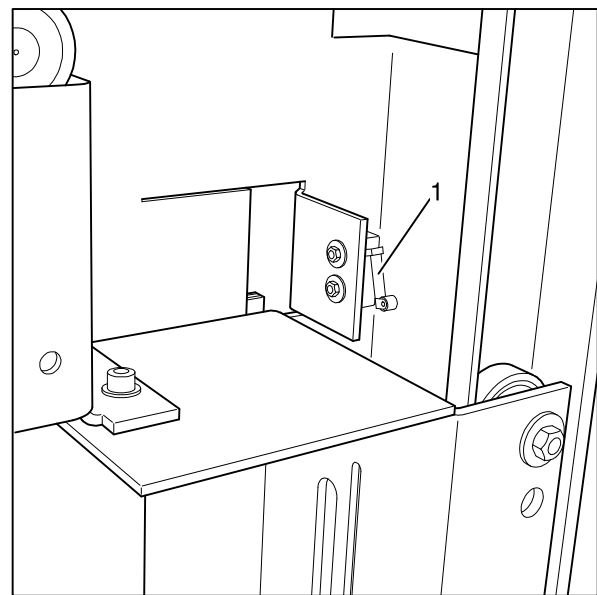

Fig.66

3.12 Bucky Movement Path Safety Switch

Move the Bucky to the foot end to the mechanical stop, move the system carriage into the exposure position. Adjust the S12 switch (Fig. 66/Pos. 1) so that it positively switches.

3.13 I.I. Carriage Movement Path Safety Switch

Remove the cover panel (Fig. 65/Pos. 1). Move the system carriage to the head end until there is 3 mm distance and adjust the switch strike plate (Fig. 67/ Pos. 1) so that it just actuates the S6 switch. Move the system carriage to the foot end until there is 3 mm distance and adjust the switch strike plate (Fig. 67/Pos. 2) so that it just actuates the S7 switch.

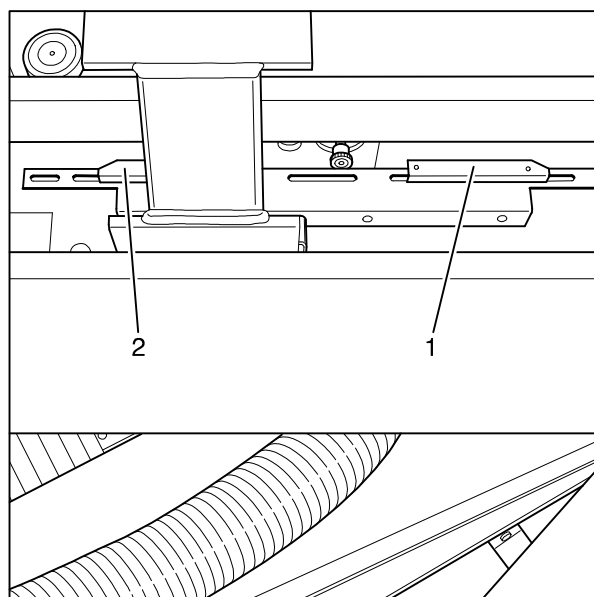

Fig.67

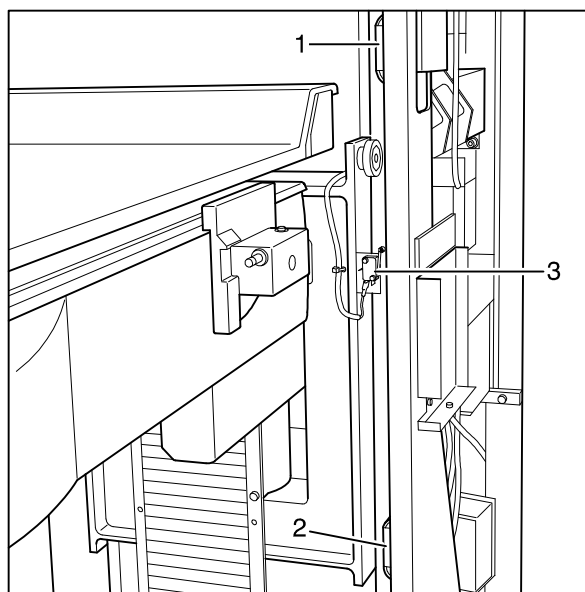

Fig.68

3.14 Table Up Movement Path Switch Strike Plate

Raise the table to max. $1225_{\pm 10}$ mm position.

When the software limit is set, the top switch strike plate (Fig. 68 / Pos. 1) can be adjusted so that the limit switch (Pos. 3) actuates approx. 2 - 5 mm behind the maximum height.

3.15 Table Down Movement Path Switch Strike Plate

Lower the table to the min. $680_{\pm 10}$ mm position.

When the software limit is set, the bottom switch strike plate (Fig. 68/ Pos. 2) can be adjusted so that the limit switch actuates approx. 2 - 5 mm behind the minimum height.

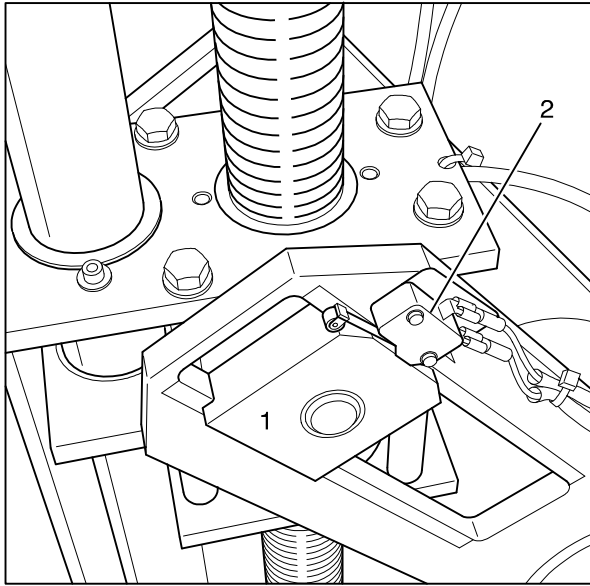

Fig.69

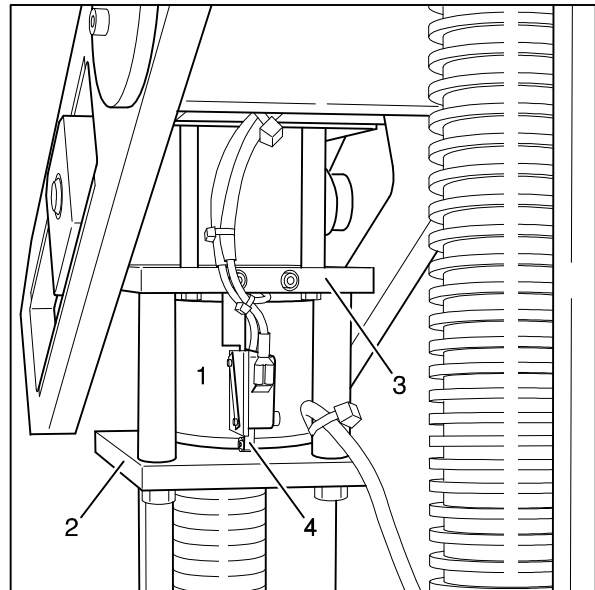

Fig.70

3.16 -20° Tilt Movement Safety Switch

Tilt the tabletop into the -20° end position.

The top of the two switches is the limit switch and the floating switch (bronze) is also the switch strike plate, respectively.

The floating switch (Fig. 69/Pos. 1) should actuate the microswitch approx. 2 mm after the end position (Pos. 2).

3.17 +88° Tilt Movement Safety Switch

Tilt the tabletop into the +88° end position.

The top of the two switches is the limit switch for tilt movement and the floating switch (bronze) is also the switch strike plate, respectively.

The floating switch (Fig. 69/Pos. 1) should actuate the microswitch (not shown in Fig. 69) approx. 2 mm after the end position.

3.18 Spindle Nut Safety Limit Switch

The safety nut (Fig. 70/Pos. 1) must be installed centered in the bottom half between the two steel plates (Pos. 2+3).

The switch strike plate in the microswitch with the roller must be up against the safety nut and actuated; when the safety nut moves up, the microswitch responds and the switch circuit is interrupted.

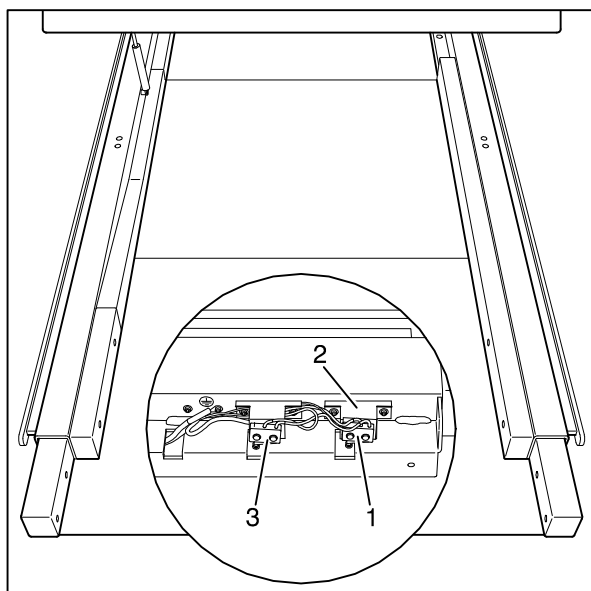

Fig.71

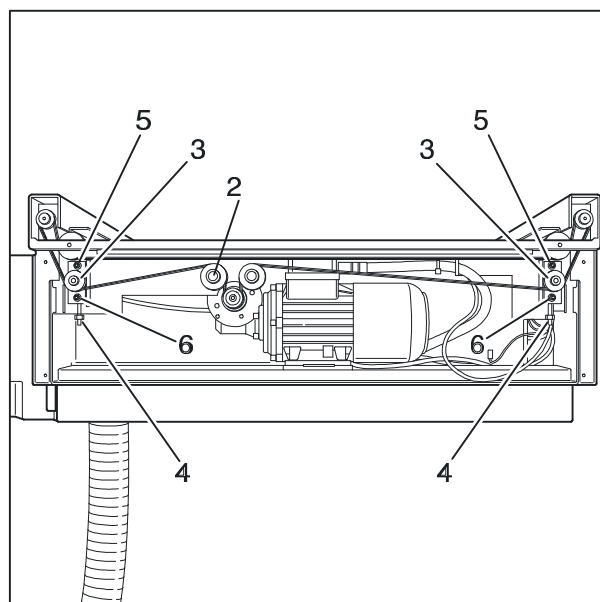

Fig.72

3.19 Accessory Sensor Switches

Securely and audibly insert the table extension or the micturation seat into the opening.

The corresponding microswitch is for sensing of the S17 table extension (Fig. 71/ Pos. 1) and S18 is for the micturation seat (Pos. 2). The switch strike plate must be adjusted so that it is on the tip of the nib so that any play will trigger a positive response of the S16 microswitch (Pos. 3).

3.20 Tabletop longitudinal Belt Tension

Belt tension should be determined as follows:

The spring balance should be placed centered between the belt return wheel (Fig. 72/Pos. 2) and the belt tension roller (Pos. 3) to achieve a deflection of 1 cm when a force of 35 N is applied. Adjustment can be made by means of the tension screw (Pos. 4) after loosening the two mounting screws (Pos. 5+6).

3.21 Raise-Lower Tabletop Belt Tension

Belt tension should be determined as follows:

The spring balance should be placed centered between the drive wheel (on motor side) and the belt wheel for the spindle (Fig. 73/Pos. 2) to achieve a deflection of 1 cm when a force of 80 N is applied. Adjustment can be made by means of the tension screw (Pos. 4) after loosening the two mounting screws (Pos. 5+6).

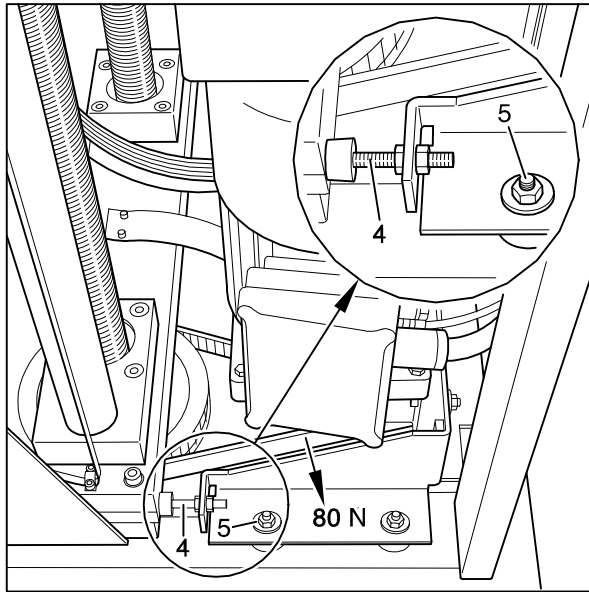

Fig.73

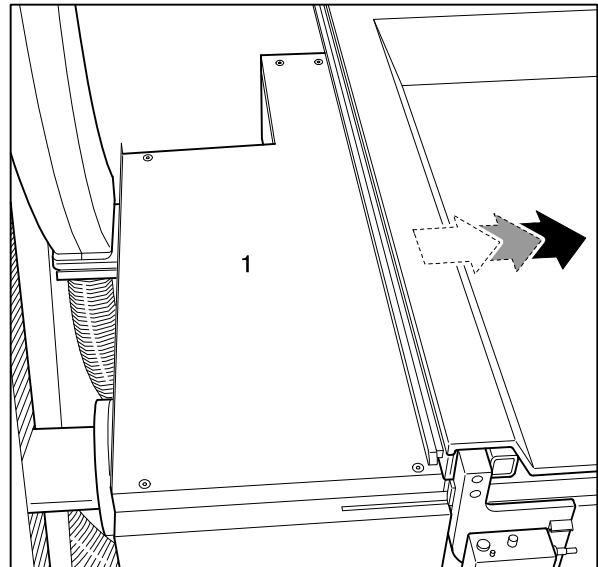

Fig. 74

3.22 Cassette Carriage Drive Belt Tension

Move the tabletop max. forward and take off the cover panel (Fig. 74/Pos. 1) after removing the 5 mounting screws.

Belt tension should be determined as follows:

The spring balance should be placed centered between the motor-side drive pulley (Fig. 75/Pos. 3) and the belt return pulley (Pos. 2) to achieve a deflection of 1 cm when a force of 25 N is applied. Adjustment can be made by means of the tension screw (Pos. 4) after loosening the 4 mounting screws (Pos. 5).

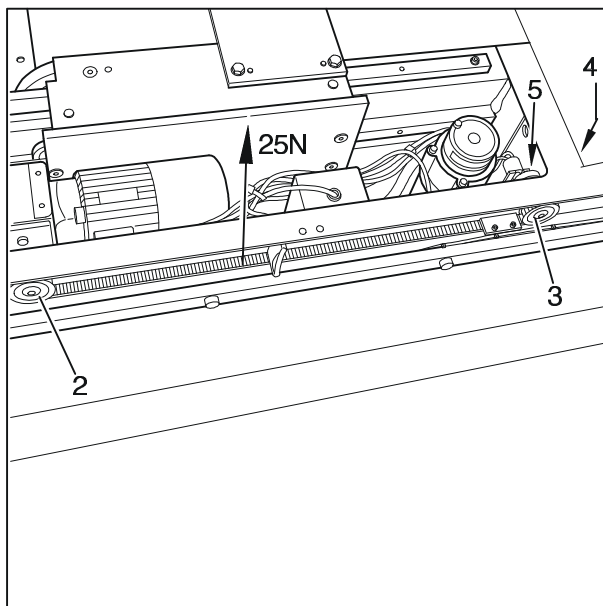

Fig.75

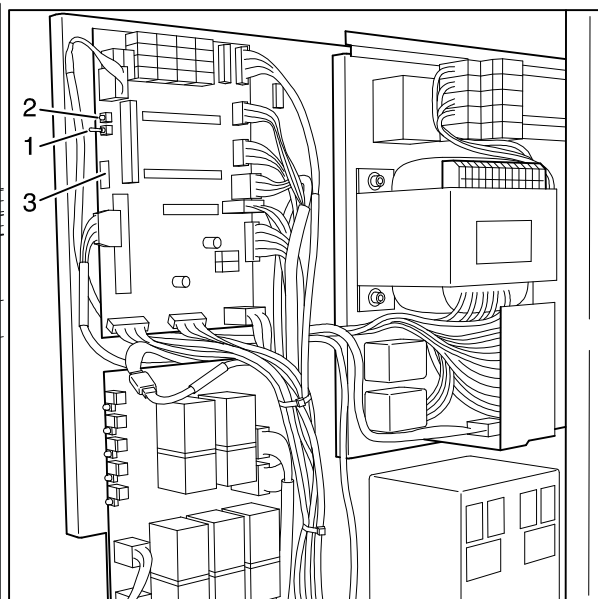

Fig. 76

3.23 Operation in the Service Mode

a. Connection of a Laptop

To establish a connection with the URO controller, a PC/laptop is required.

Equipment:

- ⇒ PC or laptop with color display (black/white is also sufficient, but makes operation more difficult)
- ⇒ 486 processor, 16 MB RAM
- ⇒ Windows 3.x Win 95 operating system (Windows NT can cause difficulties with the Com interface)
- ⇒ Hard drive
- ⇒ Serial connection cable (9-pole, Sub-D connector to a 9-pole, Sub-D socket, connected 1 - 1), length > 1m.

- ⇒ Current version of the "hp-Service" software

b. Procedure

- Switch off the URO
- Connect the PC and the URO CPU board using the connection cable
- Switch on the URO
- After approx. 1 s, the service LED will begin to blink
- Switch on the PC
- Start the PC software
- Set the PC software to monitor. The terminal screen will appear
- Set the service switch on the CPU board to the up "Service" position
- After approx. 1 s, the service LED will switch to continuously on
- The start message of the service menu will appear on the screen.

```
U  U  RRRR   OOO   333   000   000   000
U  U  R  R  O  O   3 0  00 0  00 0  00
U  U  RRRR   O  O   33  0 0 0  0 0 0  0 0
U  U  R  R   O  O   3 00 0 00 0 00 0
UUU  R  R   OOO   333   000   000   000

      Service mode

      (1) Input test
      (2) Analog test
      (3) Handcontrol and footswitch test
      (4) Axis calibration
      (5) Versioncheck

      Select testmode
```

The service technician can now start the desired adjustment. The above-listed sequence does not have to be followed when making the connection. However, it should be noted that the cable connection may not be plugged in while power is switched on!

c. Setting Parameters

A critical and often-used routine is setting the table parameters to adapt speeds or limits.

Procedure:

Once the URO controller has been set to the service mode (see above), the PC software is not switched to the monitor mode, but to the parameter mode after clicking on the "Parameters" button. (We also refer you to the Online Help of the PC software, which can be selected by pressing the F1 key).

A file window open with which the supplied adjustment file named "*.HPP" can be opened. Using data from this file, a complete parameter table is described. Please enter your name.

Data can be viewed, changed or saved this way in the usual manner.

Changing the parameters in the URO controller is performed as follows:

- ⇒ Read out the URO with "Read CPU".
- ⇒ Save these data under a new name as xxx.HPP as a backup.
- ⇒ Change the parameters as desired.
- ⇒ Write them into the URO with "Write CPU".
- ⇒ Test the new parameters.
- ⇒ If ok, save these new parameters in the URO with "EEPROM"

d. Self Test

All boards in the controller, with the exception of the breaker board, have a software self test, which is performed after switching on power. To the extent possible, this test can be viewed.

e. CPU Self Test

After switching on power, the CPU reads all inputs. This takes approx. 1 - 2 s. If this is correct, the service LED does into the blink mode.

If this does not happen, there is a malfunction.

If a peripheral unit is not connected or the bus traffic is malfunctioning, this is signaled on the display as an error code. If the display cannot be addressed, the error message can be read on the service laptop.

If an error occurs in the footswitch or in the control unit, the URO can still be operated using the other unit.

f. Display Self Test

After switching on power, all segments in the tilt display and the large round LED's are tested individually. If this does not happen, there is a malfunction.

Seven-segment display: visible by a circular sequence of the active segments. All segments must light up. If a segment does not go on, there is a malfunction.

LED's: All three LED's light up cyclically in the three colors: red, green and yellow. If one color does not appear, there is a malfunction.

g. Footswitch Self Test

This test cannot be viewed. However, correct function is signaled via the bus.

h. Control Unit Self Test

After switching on power, all LED's are individually tested by blinking, the multi-colored LED's also blink in the three colors. If this does not happen, there is a malfunction.

3.24 Startup

Adjusting the Axes

If a PC is not available, proceed as described below:

Switch the unit with the switch (Fig. 76/Pos. 1) into the service mode, the green LED (Pos. 2) on the controller goes on and stays on.

Press the Store and Reset buttons on the control unit at the same time, the three memory LED's on the control unit blink green and the LED on the controller blinks very quickly. Each axis can now be moved normally. Exception: the cassette can be moved slowly forward and backward by pressing the Recall and Reset buttons.

To save a new software limit, Store must be pressed and held (M1 LED blinks red) and the corresponding direction button for the desired movement must also be pressed.

If the controller has recognized this correctly, the M1 LED blinks red, and the position has been accepted and the keys can be released again. The M1 LED then blinks green again.

To save a centered position, the Store button must again be pressed and held and then the two buttons for the corresponding axis must either be pressed and held, or pressed in sequence.

To move past an incorrectly set software limit, the ZOOM button must be held down and the corresponding direction button must also be held. The software limit is now set to the maximum AD value.

If an axis is completely adjusted, the new limits should be saved in the EEPROM. To do this, the Store and Reset buttons must be pressed at the same time. During the save routine (approx. 5 sec) all three memory LED's will blink red.

When the save routine is completed, the memory LED's will again blink green.

3.25 Collimator Basic Setting

Switch the unit into the service mode using the switch (Fig. 77/Pos. 1), the green LED (Pos. 2) on the controller will go on and stay on. Simultaneously press the Store (Fig. 78/Pos. 54) and Reset (Pos. 56) buttons on the control unit, the three memory LED's (Pos. 51-53) on the control unit will blink green and the LED on the control unit (Fig. 77/Pos. 2) will blink very rapidly.

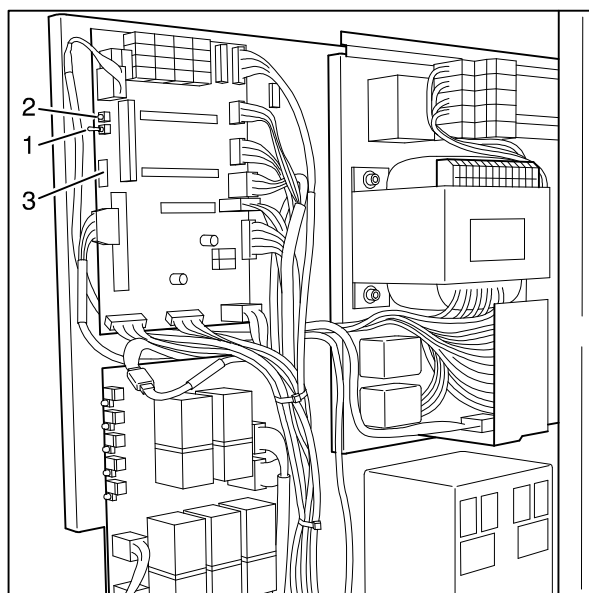

Fig. 77

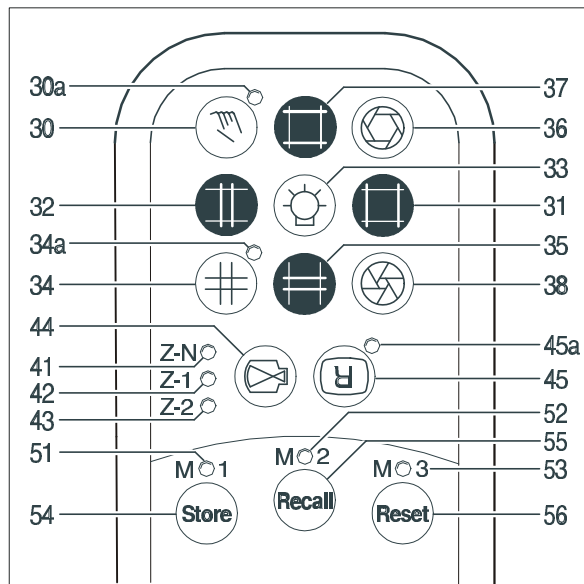

Fig. 78

The movement paths must be moved manually to the mechanical end stops using the direction buttons (the collimator plate will not move any further because the motor has a slip clutch).

Save the position that is established this way for each of the 6 end positions by holding the Store button (Fig. 78/Pos. 54) (M1 LED (Pos. 52) blinks red) and pressing the corresponding direction button for the movement at the same.

If the controller has correctly detected this position, the M1 LED (Pos. 52) goes on red. The position has been accepted and buttons can be released again. The M1 LED (Pos. 52) then blinks again green.

To move past an incorrectly set software limit, the Zoom (Pos. 54) must be pressed and held and the corresponding direction button (Pos. 31, 32, 37, 35, 36, 38) must be pressed at the same time. The software limit is now set to the maximum AD value and the axis can now be moved to a new position and stored again by pressing the Store (Pos. 54) and directional buttons (Pos. 31, 32, 37, 35, 36, 38) again.

To determine the tracking path of the motors, the collimator must be closed using the button (Pos. 34) and auto tuning started. All three collimator motors will then be started automatically 5 times and stopped again to save the tracking time that has been determined.

3.26 Setting the Collimator to the Cassette and I.I. Format

Cassette Format:

To adjust the collimator to the 4 possible film formats, the corresponding cassette must be inserted.

Use the button (Fig. 78/Pos. 33) to switch on the collimator light field and center the cassette template included in the shipment so it is centered on the tabletop.

With the light field switched on, move the collimator plates using the buttons (Fig. 78/Pos. 31, 32, 35, 37) horizontal open, horizontal closed, vertical open, vertical closed to the position of the cassette template and save the position with the Store (Pos. 54) and Light (Pos. 33) buttons.

Then as a control, make a radiographic exposure and, if needed, correct the collimator plate adjustment.

Caution:

During exposure, radiation protective measures must be observed.

Perform this routine with all 4 cassettes.

A format that has been saved previously can be overwritten by repeating the save routine.

I.I. Format:

The unit can store 3 Zoom steps.

LED`s Z-N (Pos. 41) = I.I. size, LED`s Z-1 (Pos. 42) = Zoom step 1, LED`s Z-2 (Pos. 43) = Zoom step 2, LED`s Z-1 + Z-2 (Pos. 41 + 42) = Zoom step 3.

The Zoom step is changed by pressing the Zoom button (Pos. 44).

Use the button (Fig. 78/Pos. 33) to switch on the collimator light field and center the cassette template included in the shipment on the tabletop.

Move the iris diaphragm to the desired position with the keys Iris open (Fig. 78/Pos. 38) or Iris closed (Pos. 36).

To save the currently selected zoom step, press and hold the Store button (Pos. 54) on the manual controller and then, both iris buttons (Pos. 36 and 38) should be pressed either together or in sequence.

Then the adjustment should be checked, and if needed, corrected under fluoroscopy.

Caution:

During radiographic fluoroscopy, radiation safety regulations must be observed.

Since the position of the horizontal and vertical collimator plates also need to be saved for improved radiation safety, they must be moved as exactly as possible to the limit of the iris diaphragm without them being visible in the radiation field.

Save the position of the collimator plates with the Store (Fig. 78/Pos. 54) and Light (Pos. 33) buttons.

Perform this routine for all zoom steps.

The values can be resaved as often as wished, the old settings will be overwritten when this is done.

After completing adjustment work, all parameters must be saved in the EEPROM by pressing the Reset button (Pos. 56).

The switch the unit into the normal mode with the switch (Fig. 77/Pos. 1), the green LED (Pos. 2) on the controller blinks.

3.27 Saving the Parameters in the PC

Switch off the unit. Connect the PC and the unit using the connection cable included in the shipment.

Switch the unit into the service mode with the switch (Fig. 77/Pos. 1), the green LED (Pos. 2) controller goes on continuously.

Start the URO service tool. See **3.23**

Open the parameter file included in the shipment and read the parameters from the Uromat and save them (do not overwrite the original file).

3.28 Electronic Adjustment Parameters

Setup Parameters

lf. Nr.:	Name	Min	Max	Wert
1	Tilt MAX	0	1023	
2	Tilt MIN	0	1023	
3	Tilt Null-Grad	0	1023	
4	Tilt V1 [Hz]	0	100	
5	Tilt ACC V1 [s/10]	0	255	
7	Tilt V2 [Hz]	0	100	
8	Tilt ACC V2 [s/10]	0	255	
9	Tilt DEC [s/10]	0	255	
10	Tilt DNS	0	255	
11	Vertical MAX	0	1023	
12	Vertical MIN	0	1023	
13	Vertical V1 [Hz]	0	40	
14	Vertical ACC V1 [s/10]	0	255	
15	Vertical V2 [Hz]	0	70	
16	Vertical ACC V2 [s/10]	0	255	
17	Vertical DEC [s/10]	0	255	
18	Vertical DNS	0	255	
19	System MAX	0	1023	
20	System MIN	0	1023	
21	System X-ray position	0	1023	
22	System V1 [Hz]	0	40	
23	System ACC V1 [s/10]	0	255	
24	System V2 [Hz]	0	70	
25	System ACC V2 [s/10]	0	255	
26	System DEC [s/10]	0	255	
27	System DNS	0	255	
28	Tabletop long. MAX	0	1023	
29	Tabletop long. MIN	0	1023	
30	Tabletop long. NULL	0	1023	
31	Tabletop long. V1 [Hz]	0	40	
32	Tabletop long. ACC V1 [s/10]	0	255	
33	Tabletop long. V2 [Hz]	0	70	
34	Tabletop long. ACC V2 [s/10]	0	255	
35	Tabletop long. DEC [s/10]	0	255	
36	Tabletop long. DNS	0	255	
37	Tabletop lateral MAX	0	1023	
38	Tabletop lateral MIN	0	1023	
39	Tabletop lateral NULL	0	1023	
40	Tabletop lateral V1 [PWM%]	0	150	
41	Tabletop lateral ACC V1 [s/10]	0	255	
42	Tabletop lateral V2 [PWM%]	0	255	
43	Tabletop lateral ACC V2 [s/10]	0	255	
44	Tabletop lateral DEC [s/10]	0	255	
45	Tabletop lateral DNS	0	255	
46	Cassette MAX	0	1023	
47	Cassette MIN	0	1023	
48	Cassette V1 [Hz]	0	255	
49	Cassette V2 [Hz]	0	255	
50	Cassette ACC V1 [s/10]	0	255	
51	Cassette DEC [s/10]	0	255	
52	Cassette DNS	0	255	
53	Cassette V X-ray [Hz]	0	25	
54	***** Colimator-Axisdata *****	0	0	
55	Col horizontal MAX	0	1023	
56	Col horizontal MIN	0	1023	
57	Col horizontal Format 1	0	1023	

58	Col horizontal Format 2	0	1023
59	Col horizontal Format 3	0	1023
60	Col horizontal Format 4	0	1023
61	Col horizontal delay	0	255
62	Col vertical MAX	0	1023
63	Col vertical MIN	0	1023
64	Col vertical Format 1	0	1023
65	Col vertical Format 2	0	1023
66	Col vertical Format 3	0	1023
67	Col vertical Format 4	0	1023
68	Col vertical delay	0	255
69	Iris MAX	0	1023
70	Iris MIN	0	1023
71	Iris Zoom-normal	0	1023
72	Iris Zoom-1	0	1023
73	Iris Zoom-2	0	1023
74	Iris Zoom-3	0	1023
75	Iris delay	0	255
76	***** Colimator-Zoom *****	0	0
77	Col horizontal Zoom-normal	0	1023
78	Col horizontal Zoom-1	0	1023
79	Col horizontal Zoom-2	0	1023
80	Col horizontal Zoom-3	0	1023
81	Col vertical Zoom-normal	0	1023
82	Col vertical Zoom-1	0	1023
83	Col vertical Zoom-2	0	1023
84	Col vertical Zoom-3	0	1023
85	***** Colimator *****	0	0
86	Lightvisor timer [s]	0	255
87	II Magnification [1..4]	1	4
88	Colimator-Typ [0=none]	0	0
89	Iris shut analog/digital [1/0]	0	255
90	Film cassette Detector/yes/no [2/1/0]	0	1
91	***** Image Intensifier *****	0	0
92	II depth [mm]	0	1000
93	II width-foot [mm]	0	1000
94	II width-head [mm]	0	1000
95	Distance II-center - footend [mm]	0	1023
96	***** Axis Positionmemory *****	0	0
97	Vertical store yes/no [1/0]	0	1
98	Tilt store yes/no [1/0]	0	1
99	System store yes/no [1/0]	0	1
100	Tabletop long. Store yes/no [1/0]	0	1
101	Tabletop lateral store yes/no [1/0]	0	1
102	Col horizontal store yes/no [1/0]	0	1
103	Col vertical store yes/no [1/0]	0	1
104	Iris store yes/no [1/0]	0	1
105	***** Table configuration *****	0	0
106	Slow motion [s/10]	0	255
107	Isocentric yes/no [1/0]	0	1
108	V1 isocentric [Hz]	0	255
109	V2 isocentric [Hz]	0	255
110	Uro-type right/left [1/0]	0	1
111	Tableextension [mm]	0	1000
112	Micturitionseat [mm]	0	1000
113	Elbowrests [mm]	0	1000
114	Saftydistance first [mm]	0	1000
115	Saftydistance end [mm]	0	1000

4. Technical Maintenance

NOTE:

The maintenance described below must be performed every 12 months.

If unit components need to be moved using the motor during maintenance, or if functions need to be checked while the unit is under power, the unit must be switched off immediately after reaching the new position or after completing the particular work step and the immediately disconnected from power again.

Components that are removed may only be replaced with original parts that are listed in the attached spare parts list. For maintenance, only acid-free grease may be used. Do not grease or oil bearings with seals.

4.1 Mechanical and Electrical Checks

Preparations:

- Move table to the max. up position.
- Switch power off to the system (line power)
- Remove the unit base cover cap
- Remove the unit base cover panels
- Remove the system carriage cover panels

Floor mounting:

- Check the unit column in both directions with the spirit level. Compensate any differences by using shims and retighten the mounting screws.
- Check the mounting screws for secure tightness. If needed, retighten.
Torque 25 Nm (2.5 kpm)

Manual control unit:

- Check cable lead-in for good condition and for secure connection.
- Check the function of all buttons
- Check the function of all LED's.

Multi-function footswitch:

- Check the cables for good condition and for secure connection.
If necessary, replace damaged cables.
- Clean the spaces between the individual footswitches.
- Check all switch functions.

Fluoroscopy and exposure footswitch:

- Check the cables for good condition and for secure connection.
If necessary, replace damaged cables.
- Clean the spaces between the individual footswitches.
- Check the switch functions.

Lift and tilt drive:

- Move through the entire lift and tilt range.
- Check for soft start and movement out of positions.
- Check automatic stop in the horizontal position.
- Check automatic stop in the vertical position (88°).
- Check automatic stop in the Trendelenburg position (-20°).
- Check stop with manual actuation of the limit switches.
- Clean the guide rails and the counterweight guides.
- Check for play in the bearings. If necessary, readjust them.

Tabletop drive:

- Move through the entire longitudinal and transverse movement range.
- Check for soft start and movement out of positions.
- Check automatic stop in head-end limit position.
- Check automatic stop in foot-end limit position.
- Check automatic stop in the left limit position.
- Check automatic stop in the right limit position.
- Check automatic stop in the center position.
- Lift up the tabletop and clean the space in between.

Tube unit carriage drive:

- Move through the entire movement range.
- Check soft start and movement out of positions.
- Check automatic stop in head-end limit position.
- Check automatic stop in foot-end limit position.
- Clean guide rails.
- Check for play in the bearings. If necessary, readjust them.

Bucky carriage drive:

Preparations:

Switch the unit to the service mode, the green LED on the controller goes on green continuously. Press the Store and Reset buttons at the same time, the three memory LED's on the controller will blink green and the LED on the controller will blink very quickly. See

3.24

The cassette can now be moved forward and backward slowly by pressing the Recall and Reset buttons.

- Move through the entire movement range.
- Check soft start and movement out of positions.
- Check automatic stop in head-end limit position.
- Check automatic stop in foot-end limit position.
- Clean the guide rails.
- Check for play in the bearings. If necessary, readjust.

I.I. carriage drive:

- Initiate movement through entire movement range.
- Check soft start and movement out of movements.
- Check automatic stop in head-end limit position.

- Check automatic stop in foot-end limit position
- Clean the guide rails.
- Check for play in the bearings. If necessary, readjust.

Tube unit support arm, exposure position, park position:

- Press the buttons on the control handle and move through the entire movement range.
- Check for even movement during the unit movements.
- Check for engagement into the end positions.
- Clean the guide rails.
- Check for play in the bearings. If necessary, readjust them.
- Check for fluoroscopy and exposure blocking when the tube unit support arm is not in the exposure position.

Component Panel:

- Switch power off to the system.
- Check all cables laid for good condition and secure connection.
If necessary, replace any damaged cables.
- Retighten any cable connections.
- Retighten the mounting screws of all components.
- Check P/C boards for secure seating.
- Check strain-reliefs and ground connections for secure connection.

Electronics:

- Electronic adjustment parameters per section.3.28

Accessories:

- Check all accessories present at the customer's location.
- Hook in the table extension, tilt the table and check the factory set safety distance of 12 cm; if necessary, adjust it.
- Check engagement of the leg support on the profile rail.
- Check for secure mounting of the head cushion mount.
- Check the patient table pad for good condition.
- Check the flush bowl for damage and check the function.

General:

- Reinstall the unit base cover panel.
- Reinstall the unit base cover panels.
- Reinstall the base cover panels.
- Reinstall the system carriage cover panels.
- Clean the unit.
- Clean surfaces with one of the following tested disinfecting agents:
Tego 103, Kosolin, Misty Multi-Purpose Disinfectant Cleaner, Misty Multi-Purpose Disinfectant Cleaner II, Misty Disinfectant and Deodorant RTU, Precise Hospital Foam Cleaner Disinfectant.
- Switch power back on.
- Carry out a function check according to 4.2.

4.2 Function Check

Switch on the system. Initiate movement through the entire movement path.

Vertical drive:

- Even movement?
- Automatic stop in the bottom and top positions?
- Soft start and smooth movement out?
- Movement initiated from footswitch?
- Movement initiated from manual control unit?
- Any uninitiated lowering with load applied?

Tilt drive:

- Even movement?
- Soft start and smooth movement out?
- Automatic stop in vertical limit position (88°) ?
- Automatic stop in horizontal limit position (0°) ?
- Automatic stop in Trendelenburg position (-20°) ?
- Movement initiated from footswitch?
- Movement initiated from manual control unit?
- Any uninitiated lowering with load applied?

System longitudinal movement:

- Even movement?
- Soft start and smooth movement out?
- Automatic stop in head-end limit position?
- Automatic stop in foot-end limit position?
- Movement initiated from footswitch?
- Movement initiated from manual control unit?
- Any movement with opened Bucky flap?

Tabletop longitudinal movement:

- Even movement?
- Soft bootup and soft outward movement?
- Automatic stop in the middle position?
- Automatic stop in the head-end limit position?
- Automatic stop in the foot-end limit position?
- Movement initiated from footswitch?
- Movement initiated from manual control unit?

Tabletop transverse movement:

- Even movement?
- Soft startup and soft outward movement?
- Automatic stop in the centered position?
- Automatic stop in the limit position?
- Movement initiated from footswitch?
- Movement initiated from the manual control unit?

Movable Tube Unit Support Arm:

- Easy separation in the exposure position?
- Easy separation in the park position?
- Even movement?
- Positive engagement into the limit positions?

Table extension:

- Does the table extension engage in place in the opening at the foot end?
- Is the table extension blocked from sliding out?
- Does the controller when the table extension is controlled?

Footrest:

- Does the footrest securely and easily engage the footrest?

Micturation seat:

- Does the micturation seat engage in place in the opening?
- Is the micturation seat secured against falling out?
- Does the controller sense the micturation seat?

Accessories:

- Are all configured accessories functional?

General:

- Is the centering of the tube unit to the adjustable Bucky okay?
- Is the centering of the tube unit to the I.I. okay?
- Is radiation blocked when the tube unit support arm is in the park position?

4.3 Spare Parts, Overview

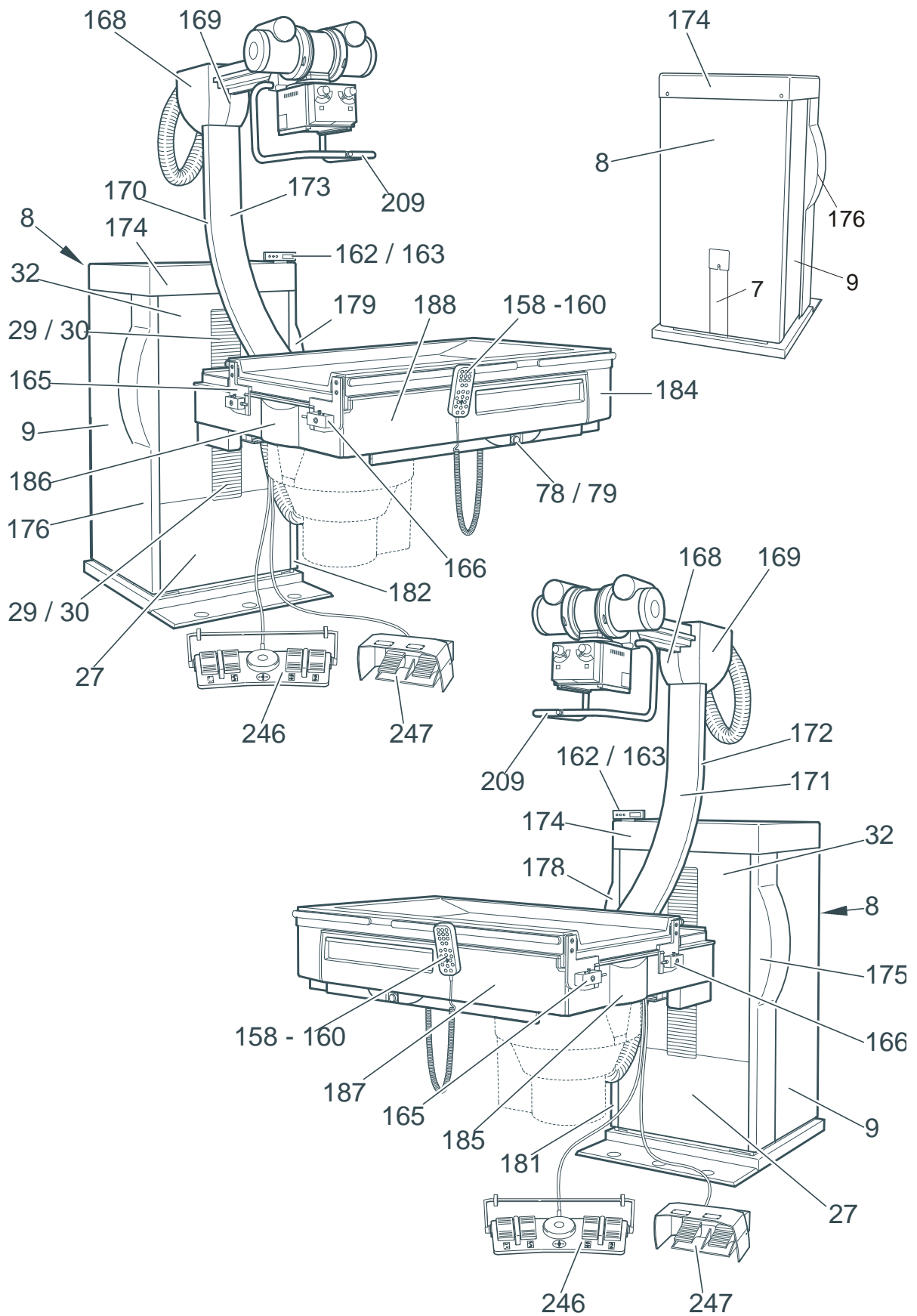

4.3.1 Spare Parts, Unit Column (Right-handed, Left-handed Versions)

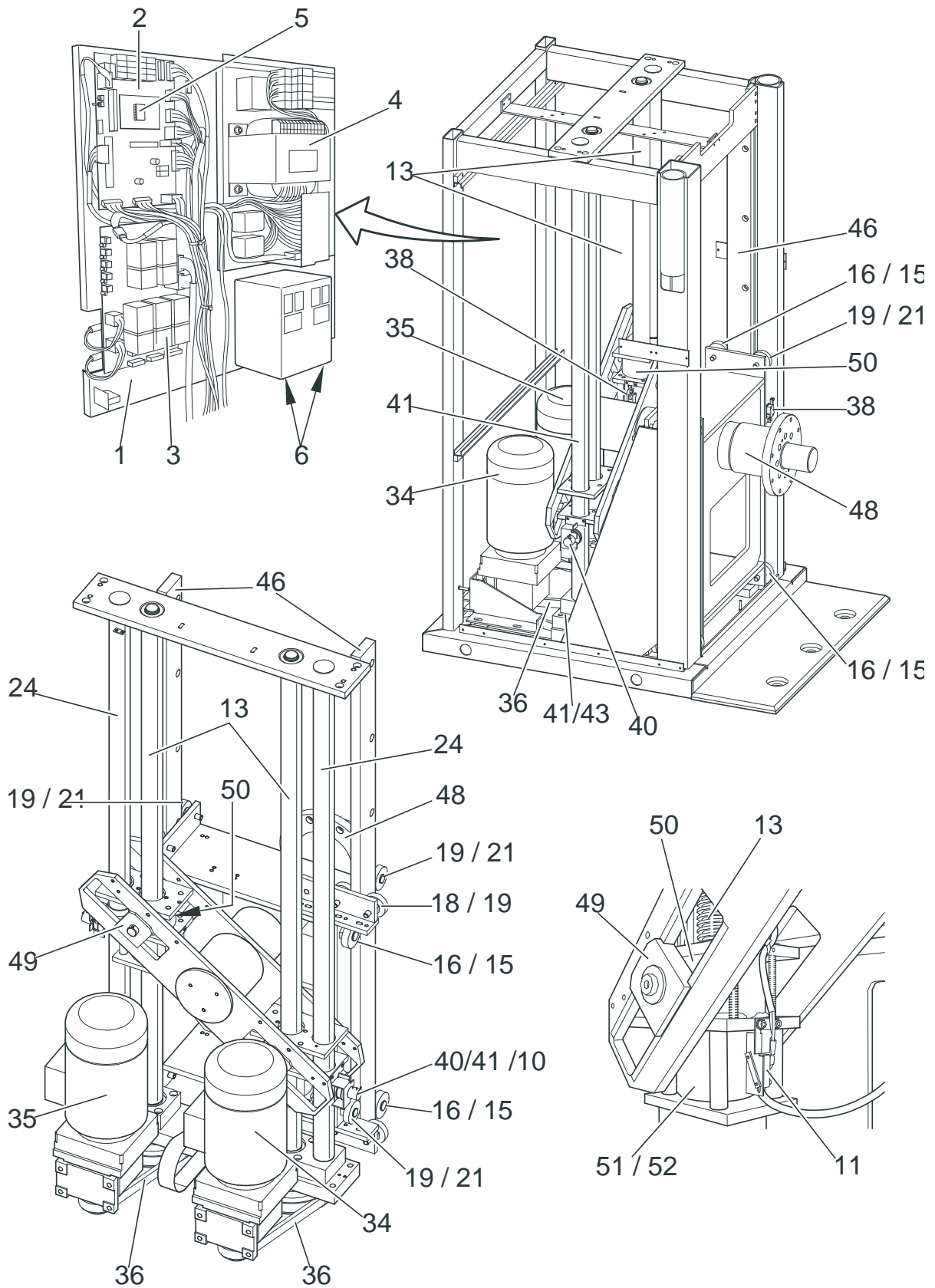

4.3.2 Spare Parts, Table Frame - Tabletop, Right-handed Version

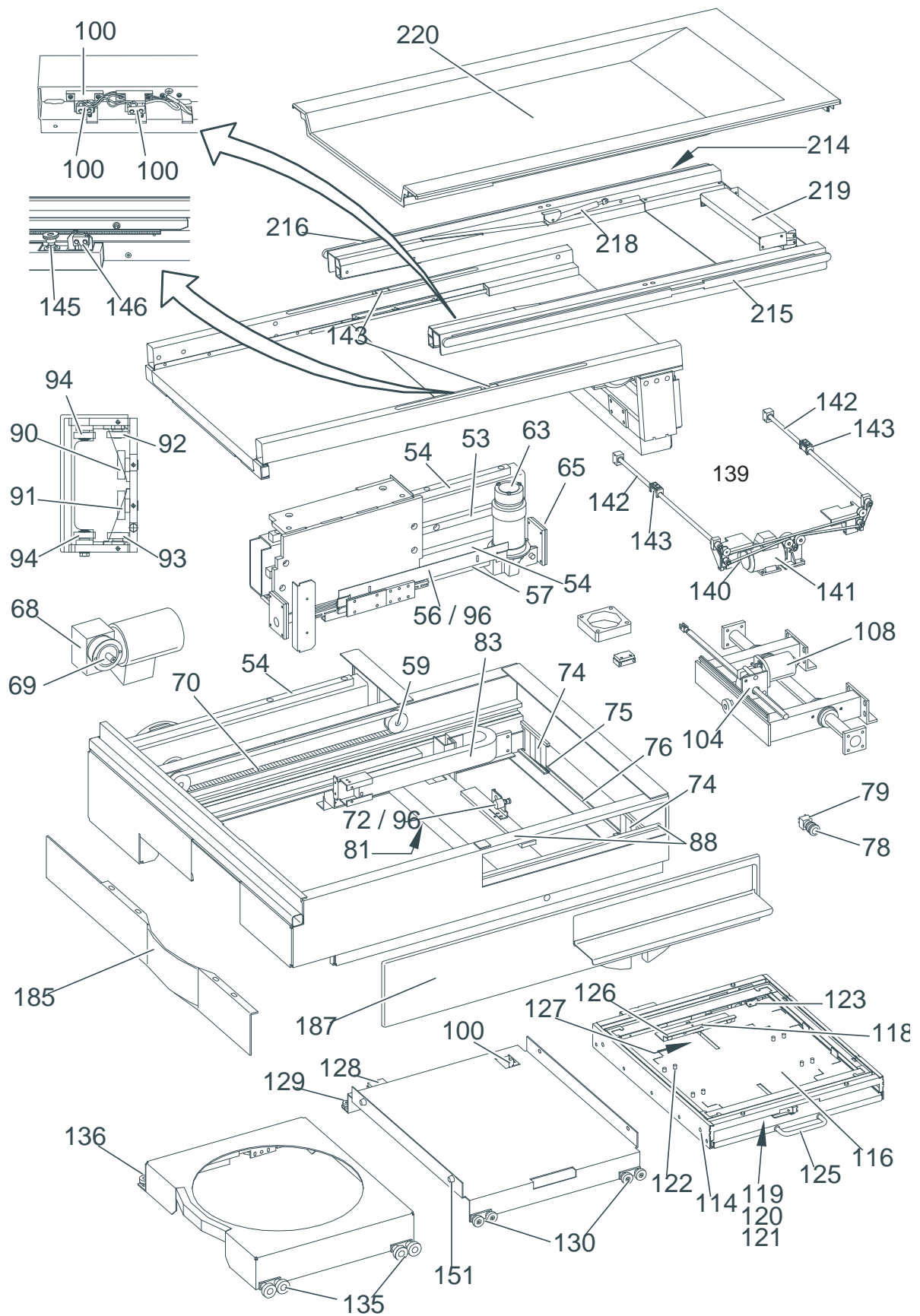

4.3.3 Spare Parts, Table Frame - Tabletop, Left-handed Version

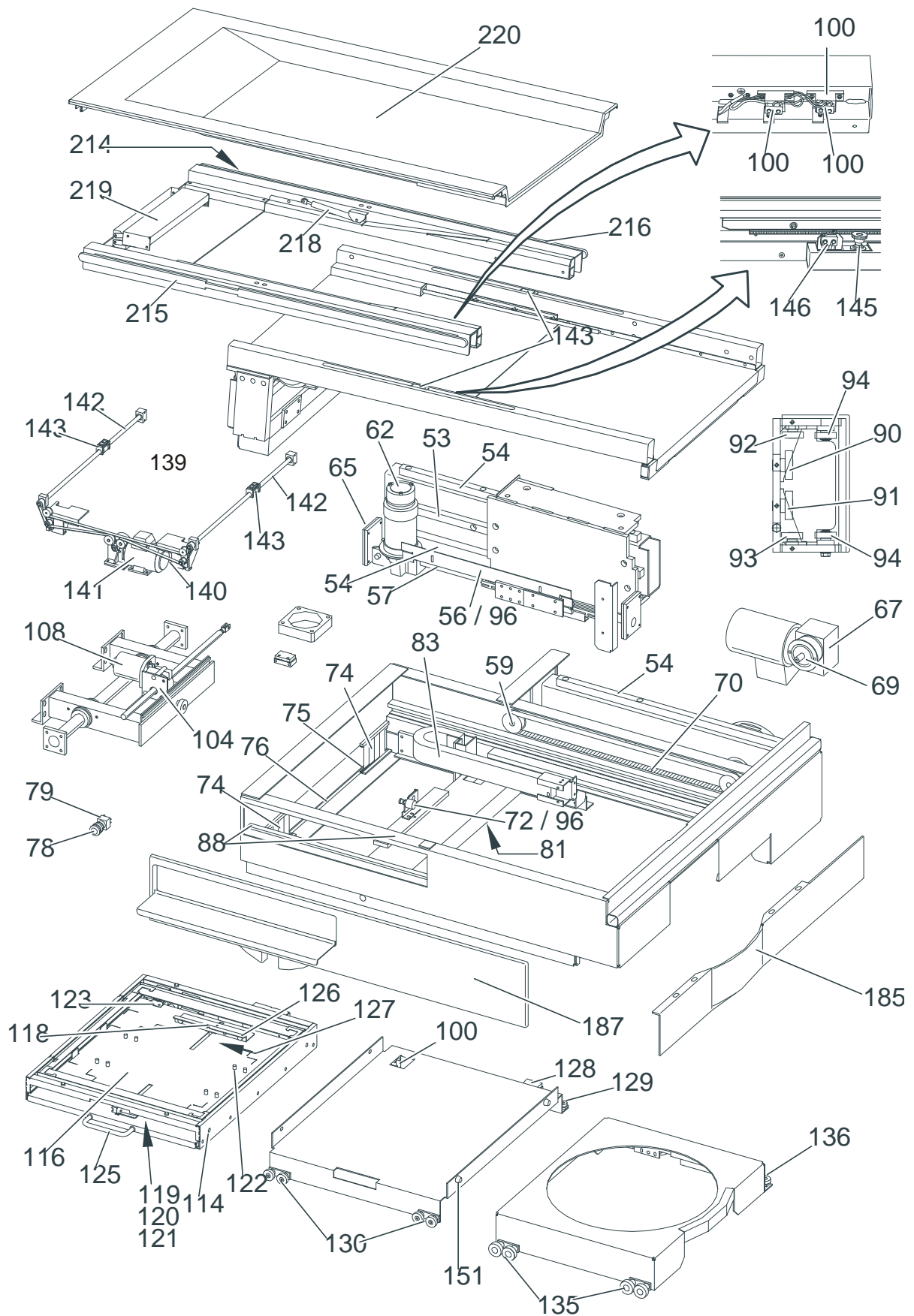

4.3.4 Spare Parts, Tube Unit Support - Right-handed Version

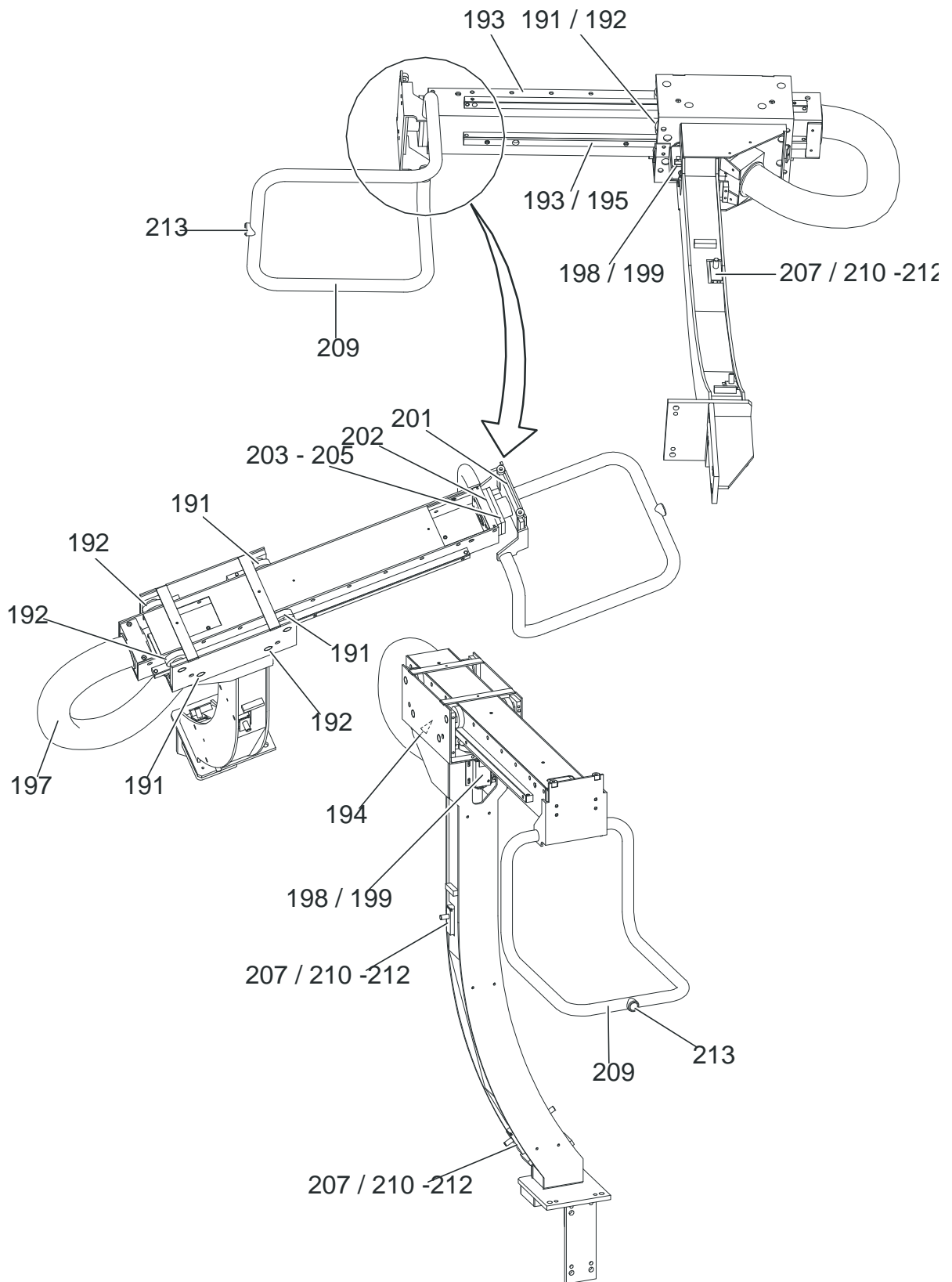

4.3.5 Spare Parts, Tube Unit Support - Left-handed Version

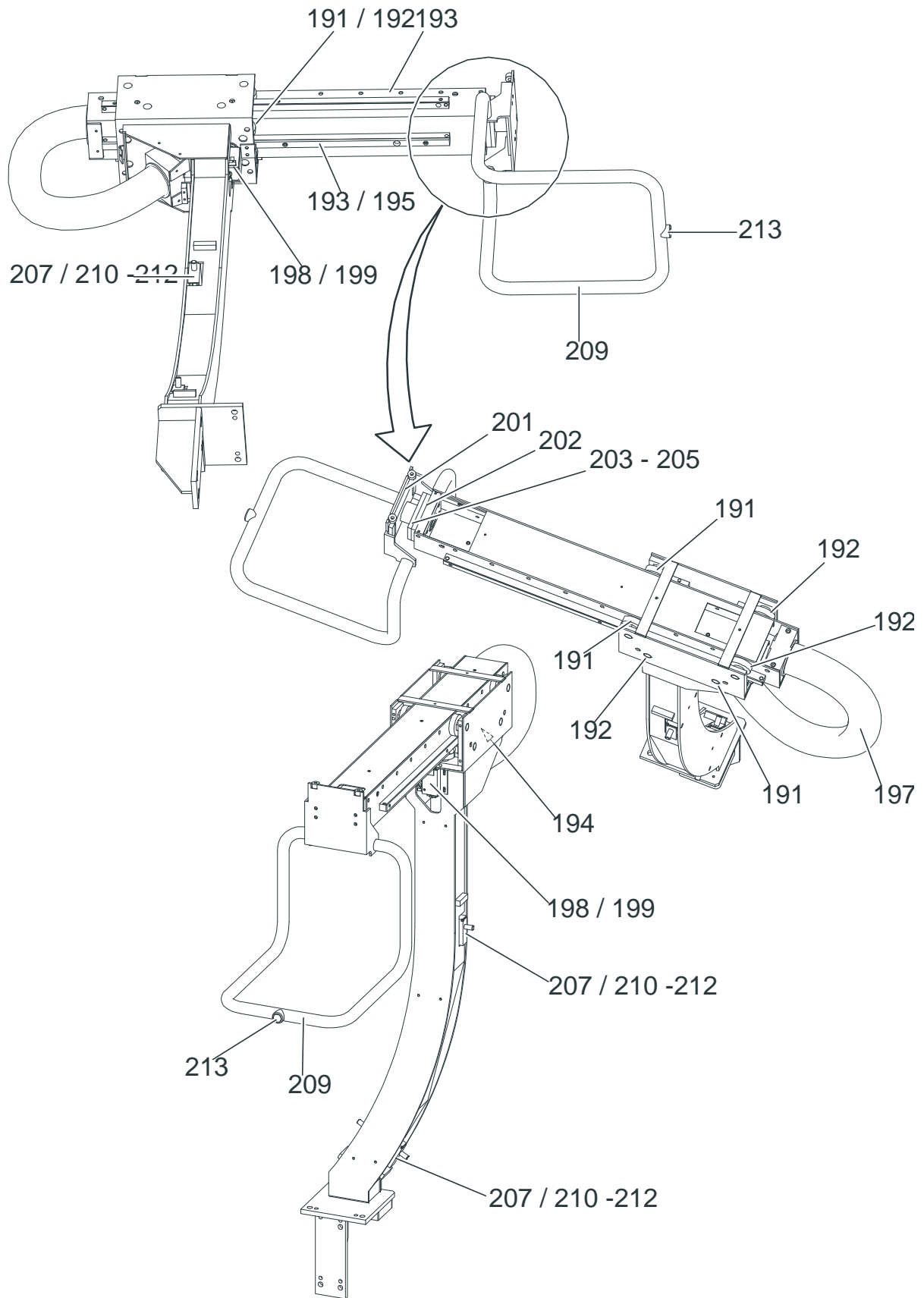

4.3.6 Spare Parts, Accessories

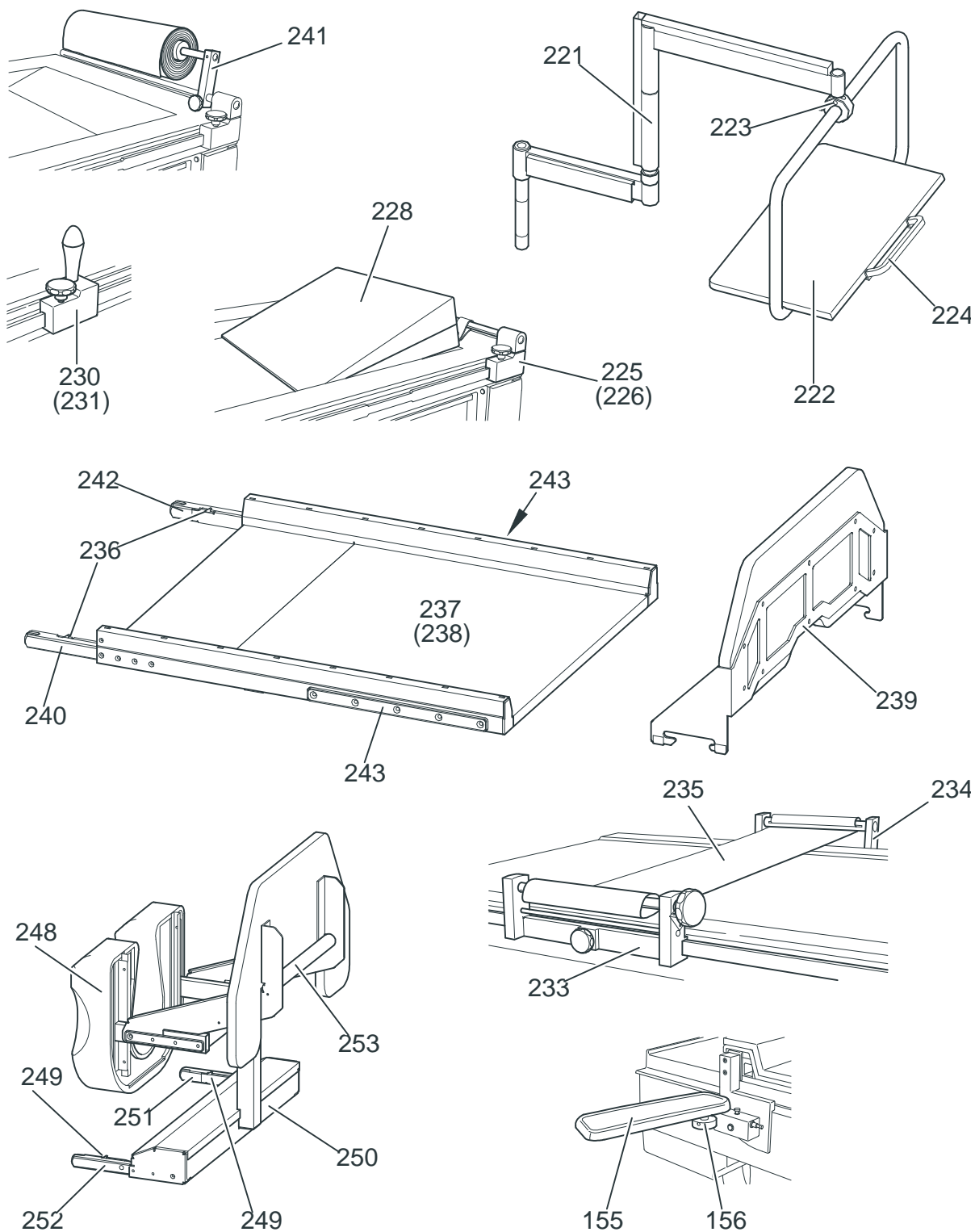

4.4 Spare Parts List

Note:

If there is a failure, components may only be replaced with the listed original parts. When ordering spare parts, always list the complete production number of the unit, the designation and the order number of the part.

Replacement of components or assemblies may only be done by us or by offices that have express authorization from us to do this. See also the chapter "Safety-technical Remarks".

Pos.	Designation	Part No.:
1	Electronics panel, complete	0116 2000
2	CPU board	0116 2020
3	Breaker assembly	0116 2025
4	Power supply	0116 2030
5	CPU	0116 2021
6	Frequency converter, three-phase	0006 0774a
7		
8	Back wall	0116 0310
9	Service door	0116 0306
10	Potentiometer, 10K, 10-turn	0006 0251b
11	Microswitch	0006 0184
12		
13	Spindle unit, installed	0116 0150
14		
15	Bearing stud, centered	0116 0421
16	Roller bearing	0005 0161i
17		
18	Bearing stud, centered	0116 0426
19	Roller bearing	0005 0161a
20		
21	Bearing stud, eccentric	0116 0431
22	Roller bearing	0005 0161a
23		
24	Complete shaft	0005 0145f
25		
26		
27	Front cover panel	0116 0303
28		
29	Roll bar 80 pcs.	0116 0333a
30	Roll bar 4 pcs.	0116 0333b
31		
32	Front cover panel	0116 0304
33		
34	Lift/tilt drive, compl.	0116 0185a
35	Lift/tilt drive, compl.	0116 0185b
36	HTD toothed belt 2 pcs.	0005 0243l
37		
38	Microswitch, complete	0116 0170
39		
40	Potentiometer, complete	0116 0171
41	Synchroflex toothed belt	0005 0170i
42		

Pos.	Designation	Part No.:
43	Clamp, potentiometer belt	0116 0174
44		
45		
46	Guide strip	0116 0135
47		
48	Tilt shaft, installed	0116 0140
49	Counterweight	0116 0164
50	Spindle nut	0116 0156
51	Locking nut	0116 0157
52	Compression spring	0005 0151au
53	Movement rail	0116 0560
54	Movement rail	0116 0561
55		
56	Switch mount	0116 0635
57	Pinion rack, installed	0116 0585
58		
59	Bearing block, installed	0116 0592
60		
61		
62	System drive, cpl.	0116 0583b
63	System drive, cpl.	0116 0583a
64		
65	Spindle bearing	0116 0567
66		
67	Worm gear drive motor, cpl.	0116 0550b
68	Worm gear drive motor, cpl.	0116 0550a
69	Synchroflex toothed belt pulley	0005 0157ae
70	Synchroflex toothed belt	0005 0146h
71		
72	Potentiometer mount, cpl.	0116 0613
73		
74	Radiation curtain guide	0116 0615
75	Radiation curtain guide	0116 0616
76	Extension spring	0116 0621
77		
78	EMERGENCY OFF switch latch	0006 0752
79	Switch element	0006 0751a
80		
81	Digital table board, cpl.	0116 2280
82		
83	Flexible plastic cable chain, cpl.	0116 0945
84		
85	Paneling screw, M 4 x 8	0005 0406d
86	Paneling screw, M 4 x 12	0005 0406k
87		
88	Reed switch	0006 0549b
89		
90	Eccentric stud	0116 1860b
91	Bearing stud	0116 1862b
92	Eccentric stud with bearing	0115 0395
93	Bearing stud with roller bearing	0115 0397
94	Roller bearing	0005 0161b
95		

Pos.	Designation	Part No.:
96	Spring, extension	0005 0040ac
97		
98	Potentiometer, cpl.	0116 0580
99		
100	Microswitch	0006 0779a
101		
102	Switch strip	0116 0589
103		
104	Pinion rack	0116 0587
105	Pinion rack	0116 0588
106		
107		
108	Worm gear drive motor	0006 0767
109	Spring, extension	0005 0040ac
110		
111	Rocker switch, cpl.	0116 0930
112	Switch strike plate	0116 0940
113	Rocker switch, cpl.	0116 0925
114	Cassette Bucky	0116 1305
115		
116	Cassette tray with sensor	0116 1335
117		
118	Cassette slider, rear	0116 1360
119	Cassette slider, front	0116 1362
120	Latching lever	0116 1383
121	Latching lever	0116 1384
122	Format stop, cpl.	0116 1389
123	Roller bearing grabber	0005 0246
124		
125	Grid handle, GN425	0005 0188b
126	Unit base	0005 0388
127	Switch, installed	0116 1410
128	Connector piece	0116 1107
129	Bearing unit	0116 1125
130	Bearing unit	0116 1110
131	Roller bearing	0005 0161b
132	Sleeve	0116 1537
133	Roller bearing stud	0116 1538
134		
135	Rocker switch	0116 0925
136	Rocker switch	0116 0930
137		
138		
139	Spindle unit, installed	0116 1540
140	Toothed belt	0005 0164h
141	Longitudinal drive, compl.	0116 1575
142	Threaded spindle	0116 1541
143	Spindle nut	0116 1542
144		
145	Potentiometer, complete	0116 1563
146	Microswitch	0006 0779a
147		
148		

Pos.	Designation	Part No.:
149		
150		
151	Rubber-metal bumper	0005 0164b
152		
153		
154		
155	Elbow support, cpl.	0900 1752
156	Outlet	0900 1754
157		
158	Control unit, cpl.	0116 2200
159	Control unit	0116 2210
160	Mount	0116 2220
161		
162	Display unit, cpl.	0116 2250
163	Display board	0116 2260
164		
165	Mount for flush bowl	0900 1703a
166	Mount for flush bowl	0900 1703b
167		
168	Housing cowl, left	0116 3024
169	Housing cowl, right	0116 3025
170	Cover panel	0116 3026
171	Cover panel	0116 3028
172	Cover panel	0116 3027
173	Cover panel	0116 3029
174	Cover	0116 3030
175	Side panel	0116 3031b
176	Side panel	0116 3031a
177		
178	Side panel	0116 3032b
179	Side panel	0116 3032a
180		
181	Side panel	0116 3033b
182	Side panel	0116 3033a
183		
184	Cover panel	0116 3050
185	Cover panel	0116 3051a
186	Cover panel	0116 3051b
187	Cover panel	0116 3053b
188	Cover panel	0116 3053a
189	Cover panel	0116 3052b
190	Cover panel	0116 3052a
191	Eccentric stud	0116 1860a
192	Bearing stud	0116 1862a
193	Movement rail	0116 1920
194	Switch mount, cpl.	0116 1855
195	Stop rail	0116 1922
196	Stop	0116 1865
197	Flexible corrugated hose	0115 0897c
198	Stop unit	0116 1988
199	Stop magnet, installed	0116 1990
200		

Pos.	Designation	Part No.:
201	Tube unit studs	0116 1930
202	Adjustment plate 10 thick	0116 1935
203	Adjustment plate 1 thick	0116 1936a
204	Adjustment plate 2 thick	0116 1936b
205	Adjustment plate 3 thick	0116 1936c
206		
207	Switch unit, installed	0116 1995
208		
209	Command arm, cpl.	0116 1950
210	Microswitch	0006 0480
211	Compression switch	0005 0151aw
212	Microswitch with roller lever	0006 0616ba
213	Button	0006 0761
214		
215	Table rail	0116 1738a
216	Table rail	0116 1738b
217		
218	Gas spring	0005 0394a
219	Hinge, installed	0116 1730
220	CFC tabletop	0116 1740
221	Monitor support arm	0900 1800
222	Monitor adjustment plate	0900 1844
223	Screw stud	0900 1846
224	Grip handle	0005 0415d
225	Mount for head cushion, right	0900 1732a
226	Mount for head cushion, left	0900 1732b
227		
228	Head cushion	0900 0085
229		
230	Handgrip	0900 0551a
231	Handgrip	0900 0551b
232		
233	Tension block	0900 0701
234	Block	0900 0702
235	Tension belt	0902 0022
236	Latch	0900 1530
237	Tabletop extension, 780 mm	0900 1500
238	Patient mat	0900 1720
239	Footrest for tabletop extension	0900 1580
240	Table insert	0900 1525a
241	Paper roll holder, incl. 1 paper roll	0900 1740
242	Table insert	0900 1525b
243	Mounting rail	0900 1518
244		
245		
246	Multi-function footswitch	0116 2320
247	Footswitch for fluoro / exposure	0900 1780
248	Seat cushion	0900 1131
249	Latch	0900 1625
250	Micturation seat, cpl. Including footrest	0900 1600
251	Insert	0900 1620b
252	Insert	0900 1620a
253	Footrest	0900 1680

5. Troubleshooting

Error Number	Cause	Corrective Measure
F 1	Frequency converter 0 for tilt/vertical, system failed.	Check connection cables, settings (address, Baud rate).
F 2	Frequency converter 1 for tilt/vertical, table longitudinal movement, cassette failed.	Check connection cables, settings (address, Baud rate).
F 3	Frequency converters 0+1 failed.	Check connection cables, settings (address, Baud rate).
F 10	Footswitch communication problem.	Check fuse, cabling.
F 11	Manual control unit communication problem.	Check fuse, cabling.
F 13	Incorrect footswitch software version.	Replace footswitch.
F 14	Incorrect manual control unit software version.	Replace manual control unit.
F 20	Analog voltage failed.	Check fuse.
F 21	M1 tilt/vertical potentiometer error.	Check potentiometer cables and potentiometer.
F 22	System potentiometer error.	Check potentiometer cables and potentiometer.
F 23	M3 tilt/vertical potentiometer error.	Check potentiometer cables and potentiometer.
F 24	Table longitudinal potentiometer error.	Check potentiometer cables and potentiometer.
F 25	Cassette potentiometer error.	Check potentiometer cables and potentiometer.
F26	Table transverse potentiometer error / motor defective.	Check motor potentiometer cables and potentiometer.
F 28	Collimator vertical potentiometer error.	Check potentiometer cables and potentiometer.
F 30	Button fuse malfunction.	Check buttons, cables.
F 31	Footswitch button sticking.	Check buttons.
F 32	Manual control unit button sticking.	Check buttons.
F 33	Exposure switch active during system start.	Check switches.
F 34	Fluoroscopy switch active during system start.	Check switches.
F 35	Exposure centering switch defective.	Check switches, cabling.

F 40	Format switch cassette incorrect.	Check 4 format switches.
F 41	M1 motor breaker stuck/defective.	Check K1 breaker.
F 42	M2 motor breaker stuck /defective.	Check K2 breaker.
F 43	M3 motor breaker stuck /defective.	Check K3 breaker.
F 44	M4 motor breaker stuck /defective.	Check K4 breaker.
F 45	M5 motor breaker stuck /defective.	Check K5 breaker.
F 46	M6 motor relay stuck /defective.	Check K19 relay (CPU board).
F 47	FU0 N>0 active.	FU0 relay defective/ input defective / check cabling.
F 48	FU1 N>0 active.	FU1 relay defective / input defective / check cabling.
F 50	Collimator malfunction.	Check cabling, potentiometers, setup parameters.
F 61	Limit switch, temperature, breaker malfunction, M1 tilt /vertical drive or M3.	Free run (press button on breaker board). Allow motor to cool down.
F 62	Limit switch, temperature, breaker malfunction, M2 system drive.	Free run (press button on breaker board). Allow motor to cool down.
F 64	Limit switch, temperature, breaker malfunction, M4 table longitudinal drive.	Free run (press button on breaker board). Allow motor to cool down.
F 79	Invalid parameter version	Initialize correct parameter version.
F 80	EEPROM memory error.	Download new parameter file.
F 99	Unit is in the service mode.	Set the service switch to the RUN mode.

F = Fatal Error = System error = cannot be corrected

6. Board Replacement

All boards are connected to each other by connectors and are replaceable. After they have been replaced correctly, they should perform a self test after power is switched on and log themselves into the CPU.

The CPU board and breaker board are accessible after opening the URO cover panel. They are seated on several round snap-on mounts, each of which must be pressed through.

The footswitch board is accessible only after opening the metal housing.

The control unit with spiral must be completely replaced.

The display with connection cable must be completely replaced.

Do not disconnect plug-in connections that are under voltage!

7. Version Update

Only the software of the CPU board can be updated to the latest version. The software in the other board cannot be updated.

The update is performed by replacing the EPROM on the processor module.

EPROM's are CMOS components. Please observe the guidelines for EMI protection.

8. MAINTENANCE VERIFICATION

Maintenance per the attached maintenance instructions has been performed. When required, parts were replaced only with original replacement parts per the listing.

Parts Replaced (list only Pos. No.)

.....
Date Company (stamp) Signature

Parts Replaced (list only Pos. No.)

.....
Date Company (stamp) Signature

Parts Replaced (list only Pos. No.)

.....
Date Company (stamp) Signature

Parts Replaced (list only Pos. No.)

.....
Date Company (stamp) Signature

Parts replaced (list only Pos. No.)

.....
Date Company (stamp) Signature

Parts replaced (list only Pos. No.)

.....
Date Company (stamp) Signature

9. Location of Identification Labels

Labeling:

see also opposite page

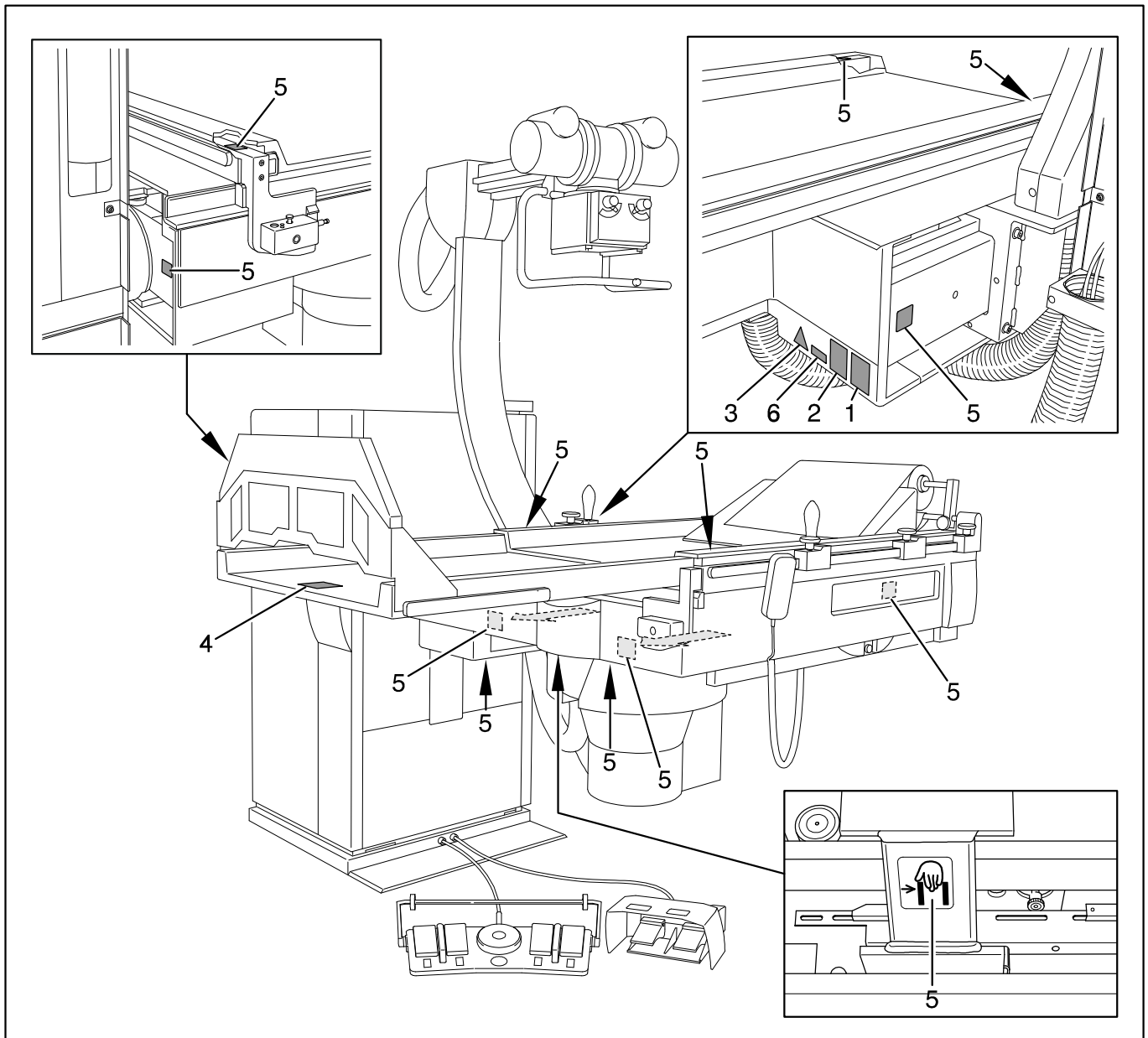

Overview of Labels:

1. Model plate

	HANS PAUSCH Röntgengerätebau
	D-91065 Erlangen Graf-Zeppelin-Str. 1
Type	<input type="text"/>
Fabr. Nr.	<input type="text"/>
Datum	<input type="text"/>
Spanng.	<input type="text"/> Volt
Frequenz	<input type="text"/> Hertz
Strom	<input type="text"/> Ampère
Made in Germany	

2. CE label



3. Observe operating instructions



4. Do not sit here - max. load, 30 kg

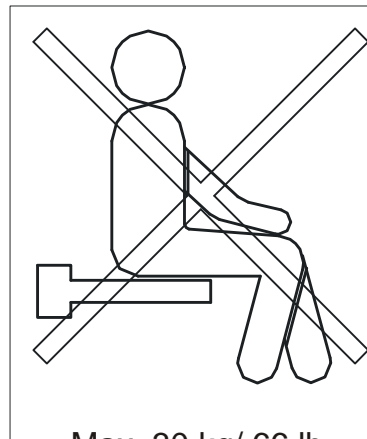

5. Caution: crush zone

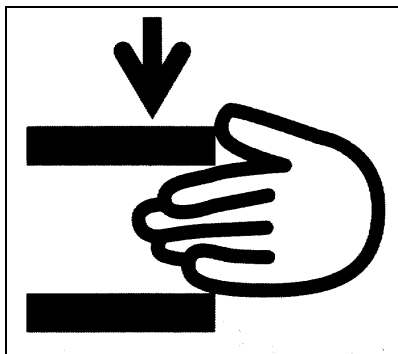

6. Inherent filtration

Eigenfilterung
(**INHERENT FILTRATION**)
= 1,0 mm AL

Notes:

We reserve the right to make changes resulting from subsequent technical advances.TV/Ru

Free Manuals Download Website

<http://myh66.com>

<http://usermanuals.us>

<http://www.somanuals.com>

<http://www.4manuals.cc>

<http://www.manual-lib.com>

<http://www.404manual.com>

<http://www.luxmanual.com>

<http://aubethermostatmanual.com>

Golf course search by state

<http://golfingnear.com>

Email search by domain

<http://emailbydomain.com>

Auto manuals search

<http://auto.somanuals.com>

TV manuals search

<http://tv.somanuals.com>