

**CHICAGO**  
**Electric Generators**

# GENERATOR

**6 HP ROBIN ENGINE RECOIL START  
2800 WATT (PEAK)**

**Model 92863**

## OPERATING INSTRUCTIONS

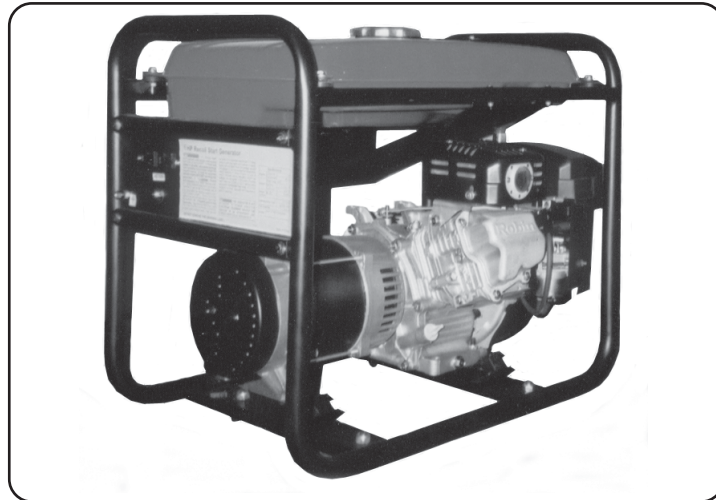

*Due to continuing improvements, actual product may differ slightly from the product described herein.*



3491 Mission Oaks Blvd., Camarillo, CA 93011

Visit our Web site at: <http://www.harborfreight.com>

**TO PREVENT SERIOUS INJURY,  
READ AND UNDERSTAND ALL WARNINGS  
AND INSTRUCTIONS BEFORE USE.**

Copyright© 2005 by Harbor Freight Tools®. All rights reserved. No portion of this manual or any artwork contained herein may be reproduced in any shape or form without the express written consent of Harbor Freight Tools.

**For technical questions, please call 1-800-444-3353.**

REV 08/05

## PRODUCT SPECIFICATIONS

Item	Description
Electrical Requirements	2800 Watt Output (Peak) 60 Hz Output Two Pole, Single Phase Alternator Overload Protection: 18 Amp Circuit Breaker Outlet Type: 20 AMP/120 VAC / 3 Prong Grounding (Qty. 2)
Engine Type	6 HP Robin® Subaru® Model #EX170D52011 Recoil Start Unleaded Gasoline Powered 3600 RPM Engine Speed 169cc Displacement Suggested Oil: F-SAE 30 (Above 32°F) / F-SAE 5W-30 (Below 32°F) Engine Approval: CARB & EPA Phase 2 Emission Compliance Fuel Tank Capacity: 3.2 Gallon Tank Run Time: 13 Hours On Full Fuel Tank @ 50% Load
Additional Features	Roll Cage For Additional Protection
Overall Dimensions	23-3/4" L x 15-5/8" W x 21-1/8" H
Unit Weight	95.7 Pounds

## SAVE THIS MANUAL

You will need this manual for the safety warnings and precautions, operating, inspection, maintenance and cleaning procedures, parts list and assembly diagram. Keep your invoice with this manual. Write the invoice number on the inside of the front cover. Keep this manual and invoice in a safe and dry place for future reference.

## UNPACKING

When unpacking, check to make sure the product is intact and undamaged. If any parts are missing or broken, please call Harbor Freight Tools at the number shown on the cover of this manual as soon as possible.

## GENERAL SAFETY RULES



**READ AND UNDERSTAND ALL INSTRUCTIONS**  
Failure to follow all instructions listed below may result in  
electric shock, fire, and/or serious injury.

**SAVE THESE INSTRUCTIONS**

REV 08/05

SKU 92863

For technical questions, please call 1-800-444-3353.

PAGE 2

## WORK AREA

1. **Keep your work area clean and well lit.** Cluttered benches and dark areas invite accidents.
2. **Do not operate the Generator and power tools in explosive atmospheres, such as in the presence of flammable liquids, gases, or dust.** Generators and power tools create sparks which may ignite the dust or fumes.
3. **Keep bystanders, children, and visitors away while operating the Generator and power tools.** Provide barriers or shields as needed.

## ELECTRICAL SAFETY

1. **Grounded tools must be plugged into an outlet properly installed and grounded in accordance with all codes and ordinances. Never remove the grounding prong or modify the plug in any way. Do not use any adapter plugs. Check with a qualified electrician if you are in doubt as to whether the outlet is properly grounded.** If the tools should electrically malfunction or break down, grounding provides a low resistance path to carry electricity away from the user.
2. **Double insulated tools are equipped with a polarized plug (one blade is wider than the other).** This plug will fit in a polarized outlet only one way. If the plug does not fit fully in the outlet, reverse the plug. If it still does not fit, contact a qualified electrician to install a polarized outlet. Do not change the plug in any way. Double insulation  eliminates the need for the three wire grounded power cord and grounded power supply system.
3. **Tools marked with “Grounding Required” have a three wire cord and a three prong grounding plug.** The plug must be connected to a properly grounded outlet. If the tool should electrically malfunction or break down, grounding provides a low resistance path to carry electricity away from the user, reducing the risk of electric shock. Do not modify the power cord plug provided with the tool. Never remove the grounding prong from the plug.
4. **Avoid body contact with grounded surfaces such as pipes, radiators, ranges, and refrigerators.** There is an increased risk of electric shock if your body is grounded.
5. **Do not expose the Generator or power tools to rain or wet conditions.** Water entering the Generator or power tools will increase the risk of electric shock.

6. **Do not abuse Power Cords on tools. Never use a Power Cord to carry the tools or pull the Plug from the Generator's outlet. Keep Power Cords away from heat, oil, sharp edges, or moving parts. Replace damaged Power Cords immediately.** Damaged Power Cords increase the risk of electric shock.

### PERSONAL SAFETY

1. **Stay alert. Watch what you are doing, and use common sense when operating the Generator. Do not use the Generator while tired or under the influence of drugs, alcohol, or medication.** A moment of inattention while operating the Generator may result in serious personal injury.
2. **Dress properly. Do not wear loose clothing or jewelry. Contain long hair. Keep your hair, clothing, and gloves away from moving parts.** Loose clothes, jewelry, or long hair can be caught in moving parts.
3. **Avoid accidental starting. Make sure the Power Switch is in its "OFF" position, and disconnect the Spark Plug Wire when not in use.**
4. **Remove adjusting keys or wrenches before turning the Generator on.** A wrench or a key that is left attached to a rotating part of the Generator may result in personal injury.
5. **Do not overreach. Keep proper footing and balance at all times.**
6. **Use safety equipment. Always wear eye protection.** Wear ANSI approved safety impact eye goggles when operating the Generator. Dust mask, non-skid safety shoes, hard hat, or hearing protection must be used for appropriate conditions.
7. **Do not force the Generator. Use the Correct Generator for your application.** The correct Generator will do the job better and safer at the rate for which it is designed.
8. **Do not use the Generator if the Power Switch does not turn it on or off.** Any Generator that cannot be controlled with the Power Switch is dangerous and must be replaced.

### GENERATOR USE AND CARE



1. **Make sure the Power Switch is in its "OFF" position and disconnect the spark plug wire before making any adjustments, changing accessories, or storing the Generator.** Such preventive safety measures reduce the risk of starting the Generator accidentally.

2. **Store idle generators out of reach of children and other untrained persons.** Generators are dangerous in the hands of untrained users.
3. **Maintain the Generator with care.** Do not use a damaged Generator. Tag damaged Generators “Do not use” until repaired.
4. **Check for misalignment or binding of moving parts, breakage of parts, and any other condition that may affect the generator’s operation. If damaged, have the Generator serviced before using.** Many accidents are caused by poorly maintained Generators.
5. **Use only accessories that are recommended by the manufacturer for your model.** Accessories that may be suitable for one Generator may become hazardous when used on another Generator.

### SERVICE

1. **Generator service must be performed only by qualified repair personnel.** Service or maintenance performed by unqualified personnel could result in a risk of injury.
2. **When servicing a Generator, use only identical replacement parts. Follow instructions in the “*Inspection, Maintenance, And Cleaning*” section of this manual.** Use of unauthorized parts or failure to follow maintenance instructions may create a risk of electric shock or injury.

### SPECIFIC PRODUCT WARNINGS AND PRECAUTIONS

1.  **WARNING!** The warnings, precautions, and instructions discussed in this manual cannot cover all possible conditions and situations that may occur. The operator must understand that common sense and caution are factors, which cannot be built into this product, but must be supplied by the operator.
2.  **WARNING!** People with pacemakers should consult their physician(s) before using this product. Electromagnetic fields in close proximity to a heart pacemaker could cause interference or failure of the pacemaker. In addition, people with pacemakers should adhere to the following: Caution is necessary when near the coil, spark plugs, or distributor of a running engine. The engine should always be off if adjustments are to be made to the distributor.
3. **Industrial applications must follow OSHA requirements.**

4. **Maintain labels and nameplates on the Generator.** These carry important information. If unreadable or missing, contact Harbor Freight Tools for a replacement.

### **Installation Precautions:**

1.  **WARNING!** Before using the Generator, read and understand the *Engine manufacturer's Operation, Maintenance, and Parts manual*. Also, read the safety precautions in *this manual*. These should always be followed to reduce the risk of personal injury and damage to equipment.
2. Ensure installation meets all applicable safety, and local and national electrical codes. Have installation performed by a qualified, licensed electrician and building contractor.
3. All electrical work, including the earth-ground connection, should be completed by a licensed electrician.
4. Any separate fuel storage Generator supply facility must be built or installed in full compliance with all relevant local, state, and federal regulations.
5. If the Generator is installed indoors, exhaust fumes must be piped out of the building using leak-free, heat-resistant piping. **Use the Generator only in well ventilated outdoor areas. Carbon monoxide fumes are a colorless, odorless gas that, if inhaled, can cause serious injury or death.** Pipes and silencer should not use any flammable materials, nor should they be installed near the same. Generator exhaust fumes must be within legal limits.
6. If the Generator is installed outdoors, it must be weatherproofed and should be soundproofed. It should not be run outdoors without protection to the Generator and wiring conduit.
7. Never lift the Generator using the engine or alternator lifting lugs. Connect lifting equipment to the Frame of the Generator.
8. Before lifting the Generator, ensure the lift rigging and supporting structure are in good condition, and are rated to lift such a load.
9. Keep all personnel away from the suspended Generator during relocating.
10. The supporting floor/ground surface should be level, and strong enough to safely hold the weight of the Generator. If the floor/ground surface is not level, strong cross members should be placed under the full length of the Generator Frame at its low side.

11. For trailer installation, the Generator should be mounted on the center point of the trailer, over the wheels. Consult your local DMV for possible installation regulations.
12. Install sound and weather proofing only when it is not raining or snowing to avoid trapping moisture within the Generator's area.

### **Fire And Explosion Precautions:**

1. Gasoline fuel and fumes are flammable, and potentially explosive. Use proper fuel storage and handling procedures. Always have multiple ABC class fire extinguishers nearby.
2. Keep the Generator and surrounding area clean at all times.
3. When spills of fuel or oil occur, they must be cleaned up immediately. Dispose of fluids and cleaning materials as per any local, state, or federal codes and regulations. Store oil rags in a covered metal container.
4. Never store fuel or other flammable materials near the Generator.
5. Do not smoke, or allow sparks, flames or other sources of ignition around the Engine and Fuel Tank. Fuel vapors are explosive.
6. Keep grounded conductive objects, such as tools, away from exposed, live electrical parts and connections to avoid sparking or arcing. These events could ignite fumes or vapors.
7. **Do not refill the Fuel Tank while the Engine is running or while the Engine is still hot. Do not operate the Generator with known leaks in the fuel system.**
8. Excessive buildup of unburned fuel gases in the exhaust system can create a potentially explosive condition. This buildup can occur after repeated failed start attempts, valve testing, or hot engine shutdown. If this occurs, open exhaust system drain plugs, if equipped, and allow the gases to dissipate before attempting to restart the Generator.
9. Use only engine manufacturer recommended fuel and oil.

### **Mechanical Precautions:**

1. **ALWAYS** make sure the Power Switch is in its "OFF" position. Disconnect the spark plug wire, and allow the Engine to completely cool before carrying out maintenance.

2. Check for damaged parts. Before using the Generator, any part that appears damaged should be carefully checked to determine that it will operate properly and perform its intended function. Check for alignment and binding of moving parts, any broken parts or mounting fixtures, and any other condition that may affect proper operation. Any part that is damaged should be properly repaired or replaced by a qualified technician.
3. The Generator is designed with guards for protection from moving parts. In any case, care must still be taken to protect personnel and equipment from other mechanical hazards when working around the generator.
4. Do not operate the Generator with safety guards removed. While the Generator is running, do not attempt to reach around the safety guards for maintenance or any other reason.
5. Keep hands, arms, long hair, loose clothing, and jewelry away from moving parts. Be aware that when engine parts are moving fast they cannot be seen clearly.
6. Keep access doors on enclosures closed and locked when access is not required.
7. When working on or around the Generator always wear protective clothing including ANSI approved safety gloves, safety eye goggles, and safety hat.
8. Do not alter or adjust any part of the Generator that is assembled and supplied by the manufacturer.
9. Always follow and complete scheduled Engine and Generator maintenance.

**Chemical Precautions:**

1. Avoid contact with hot fuel, oil, exhaust fumes, and solid surfaces.
2. Avoid body contact with fuels, oils, and lubricants used in the Generator. If swallowed, seek medical treatment immediately. Do not induce vomiting if fuel is swallowed. For skin contact, immediately wash with soap and water. For eye contact, immediately flush eyes with clean water.

**Noise Precautions:**

1. Prolonged exposure to noise levels above 85 dBA is hazardous to hearing. Always wear ANSI approved ear protection when operating or working around the Generator when it is running.



**Electrical Precautions:**

1. All connections and conduits from the Generator to the load must only be installed by trained and licensed electricians, and in compliance with all relevant local, state, and federal electrical codes and standards, and other regulations where applicable.
2. The Generator must be earth-grounded in accordance with all relevant electrical codes and standards before operation.
3. If an extension cord (not included) is used, make sure to use only UL<sup>®</sup> listed cords having the correct gauge and length. **(See Figure A.)**
4. Do not attempt to connect or disconnect load connections while standing in water, or on wet or soggy ground.
5. Do not touch electrically energized parts of the Generator and interconnecting cables or conductors with any part of the body, or with any non-insulated conductive object.
6. Connect the generator only to a load or electrical system (120 volt) that is compatible with the electrical characteristics and rated capacities of the Generator.
7. Before servicing equipment powered by the Generator, disconnect the equipment from its power input.
8. Keep all electrical equipment clean and dry. Replace any wiring where the insulation is cracked, cut, abraded or otherwise degraded. Replace terminals that are worn, discolored, or corroded. Keep terminals clean and tight.

<b>RECOMMENDED MINIMUM WIRE GAUGE FOR EXTENSION CORDS* (110 VOLT)</b>					
<b>NAMEPLATE AMPERES (At Full Load)</b>	<b>EXTENSION CORD LENGTH</b>				
	<b>25 FEET</b>	<b>50 FEET</b>	<b>75 FEET</b>	<b>100 FEET</b>	<b>150 FEET</b>
<b>0-2.0</b>	<b>18</b>	<b>18</b>	<b>18</b>	<b>18</b>	<b>16</b>
<b>2.1-3.4</b>	<b>18</b>	<b>18</b>	<b>18</b>	<b>16</b>	<b>14</b>
<b>3.5-5.0</b>	<b>18</b>	<b>18</b>	<b>16</b>	<b>14</b>	<b>12</b>
<b>5.1-7.0</b>	<b>18</b>	<b>16</b>	<b>14</b>	<b>12</b>	<b>12</b>
<b>7.1-12.0</b>	<b>16</b>	<b>14</b>	<b>12</b>	<b>10</b>	<b>-</b>
<b>12.1-16.0</b>	<b>14</b>	<b>12</b>	<b>10</b>	<b>-</b>	<b>-</b>
<b>16.1-20.0</b>	<b>12</b>	<b>10</b>	<b>-</b>	<b>-</b>	<b>-</b>

**\*Based on limiting the line voltage drop to five volts at 150% of the rated amperes.**

**FIGURE A**

9. Insulate all connections and disconnected wires.
10. Guard against electric shock. Prevent body contact with grounded surfaces such as pipes, radiators, ranges, and refrigerator enclosures.
11. Use only Class BC or Class ABC fire extinguishers on electrical fires.

## INSTALLATION

1. **NOTE:** Prior to powering tools and equipment, make sure the Generator's rated voltage, wattage, and amperage capacity (120V/20 AMPs) is adequate to supply all electrical loads that the unit will power. If powering exceeds the Generator's capacity, it may be necessary to group one or more of the tools and/or equipment for connection to a separate Generator.
2. Electrical and other permits may be required for the installation of emergency power systems. Investigate the local building and electrical codes before installing this unit. Installation must be completed by licensed contractors.
3.  **WARNING!** The Generator weighs 95.7 Lbs. (without fuel). Use care and the proper lifting or hoisting equipment when moving it to the installation location. Always connect hoist lines to the Frame (18) of the Generator.

## GENERAL LOCATION

1. It is recommended to locate and install the Generator outdoors where cooling air is readily available.
2. Install the Generator so that the air inlets and outlets are not blocked by obstructions such as bushes, trees, or snow drifts. Locating it in the path of heavy winds or snowdrifts may require the placement of a barrier for protection. The air inlet, in normal weather conditions, should face the prevailing wind direction.
3. Install the Generator on a concrete slab or other area where rain drainage or flood waters can not reach it.
4. Generator placement should allow four feet of access to all sides for maintenance.

5. Place the Generator as close as possible to the electrical tools and equipment being powered to reduce the length of extension cords.
6. If the Generator is located indoors, or in a Generator house, the Engine exhaust must be ventilated to the outdoors using leakproof, heat resistant, flexible, metal, flex tubing.

## GENERATOR SUPPORT AND MOUNTING

1. Mount the Generator on a concrete slab capable of supporting the weight of the Generator. The slab must extend on all sides beyond the Frame (18) by at least one foot. Contact a cement contractor for slab specifications if necessary. Attach the Frame to the concrete slab using 3/8" diameter expansion anchor bolts (not supplied).

## GROUNDING THE GENERATOR

1. **NOTE:** It is recommended that only a trained and licensed electrician perform this procedure.
2. Connect a #6 AWG grounding wire (not included) from the Ground Connector (17) on the Generator to a grounding rod (not included) that has been driven at least *24 inches* deep into the earth. The grounding rod must be an earth-driven copper or brass rod (electrode) which can adequately ground the Generator. (See Figure B.)

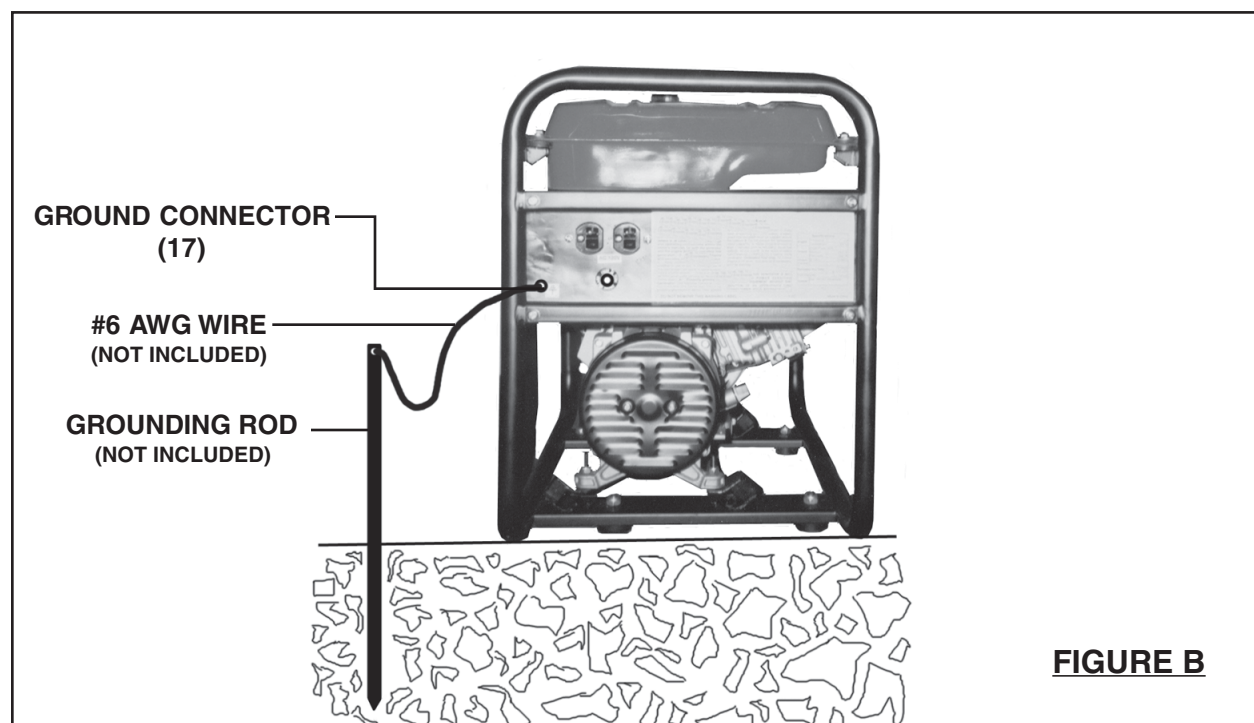

**FIGURE B**

## OPERATING INSTRUCTIONS

### NOTE:

For additional references to the parts discussed in the following pages, refer to the **Assembly Diagram on page 18** of this manual.

### ***Pre-Start Checks:***

1. Before operation, it will be necessary to refer to the *Engine manufacturer's Operation, Maintenance, and Parts manual* (included) for detailed information about starting, running, and stopping the Engine.
2. **IMPORTANT!** Engine oil **MUST** be added to the Engine's crankcase prior to starting and running the Engine. Failure to add oil, according to the Engine manufacturer's recommendations, will damage the Engine and void its warranty.
3. Check to make sure the Engine's "ON/OFF" Switch is in its "**OFF**" position. (See Figure C.)
4. *Unscrew* and remove one of the Engine's Oil Dipsticks located on both sides at the bottom of the Engine Crankcase. Fill the Engine's crankcase with the proper *type* and *amount* of engine oil as recommended by the Engine manufacturer. Then, replace the Oil Dipstick. (See Figure C.)

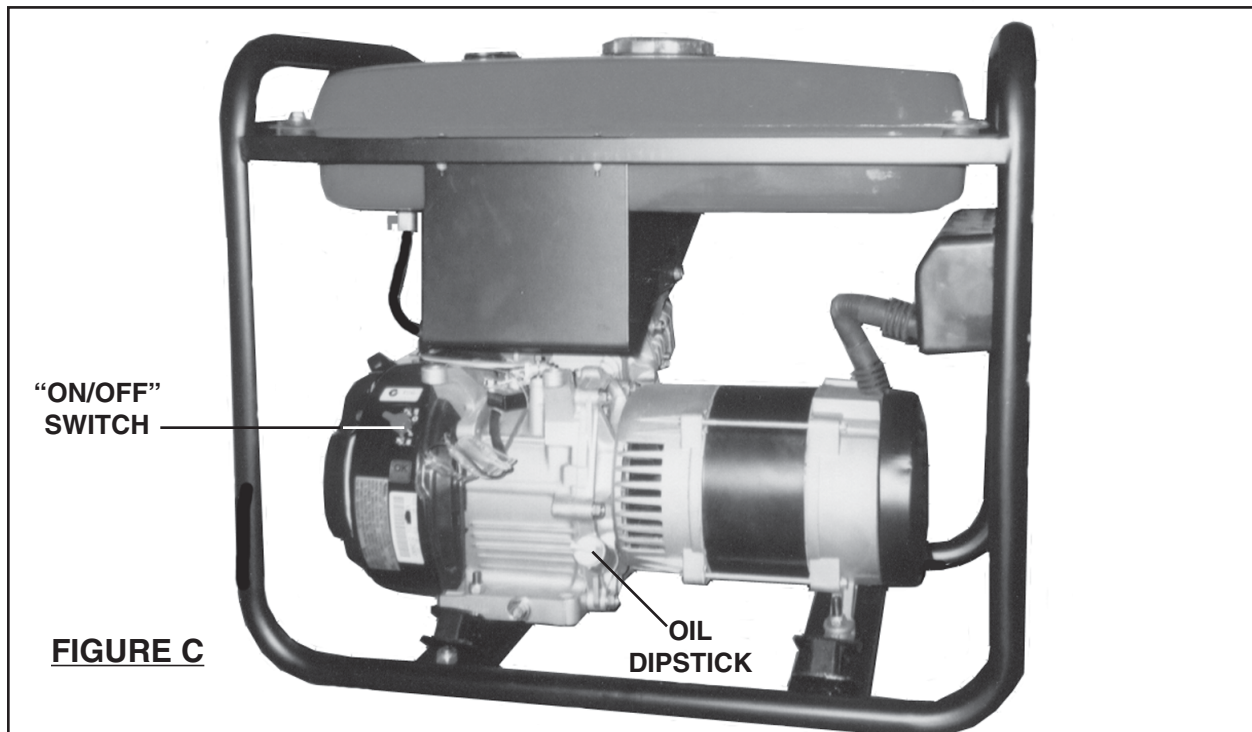

5. Before the first use, remove the Fuel Tank Cap (30) and fill the Fuel Tank (26) with unleaded gasoline. Then, replace the Fuel Tank Cap. Thereafter, check the Engine's Fuel Gauge (27) for the amount of *unleaded* gasoline in the Fuel Tank. If necessary, refill the Fuel Tank with unleaded gasoline. **(See Figure D.)**

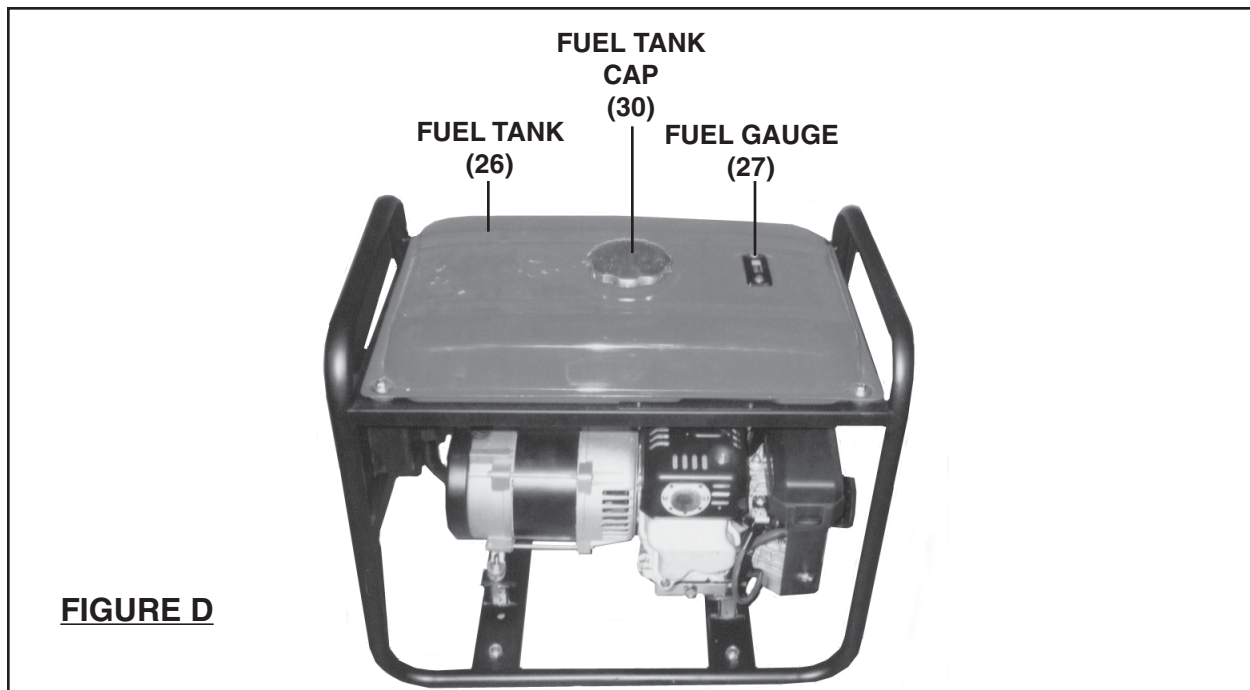

### **To Start The Generator:**

1. **IMPORTANT!** Engine oil **MUST** be added to the Engine's crankcase prior to starting and running the Engine. Failure to add oil, according to the Engine manufacturer's recommendations, will damage the Engine and void its warranty.
2. Turn the Fuel Valve (25) to its "OPEN" position. **(See Figure E, next page.)**
3. Move the Engine's Fuel Choke to its "START" position. **(See Figure E.)**
4. Turn the Engine's "ON/OFF" Switch to its "ON" position **(See Figure E.)**
5. Grasp the Handle of the Engine's Starter Rope and rapidly pull the Starter Rope to start the Engine. **NOTE:** It may take one or more pulls on the Starter Rope to start the Engine.
6. Allow the Engine to run for several seconds, then move the Engine's Fuel Choke all the way to the left to its "RUN" position. **(See Figure E.)**

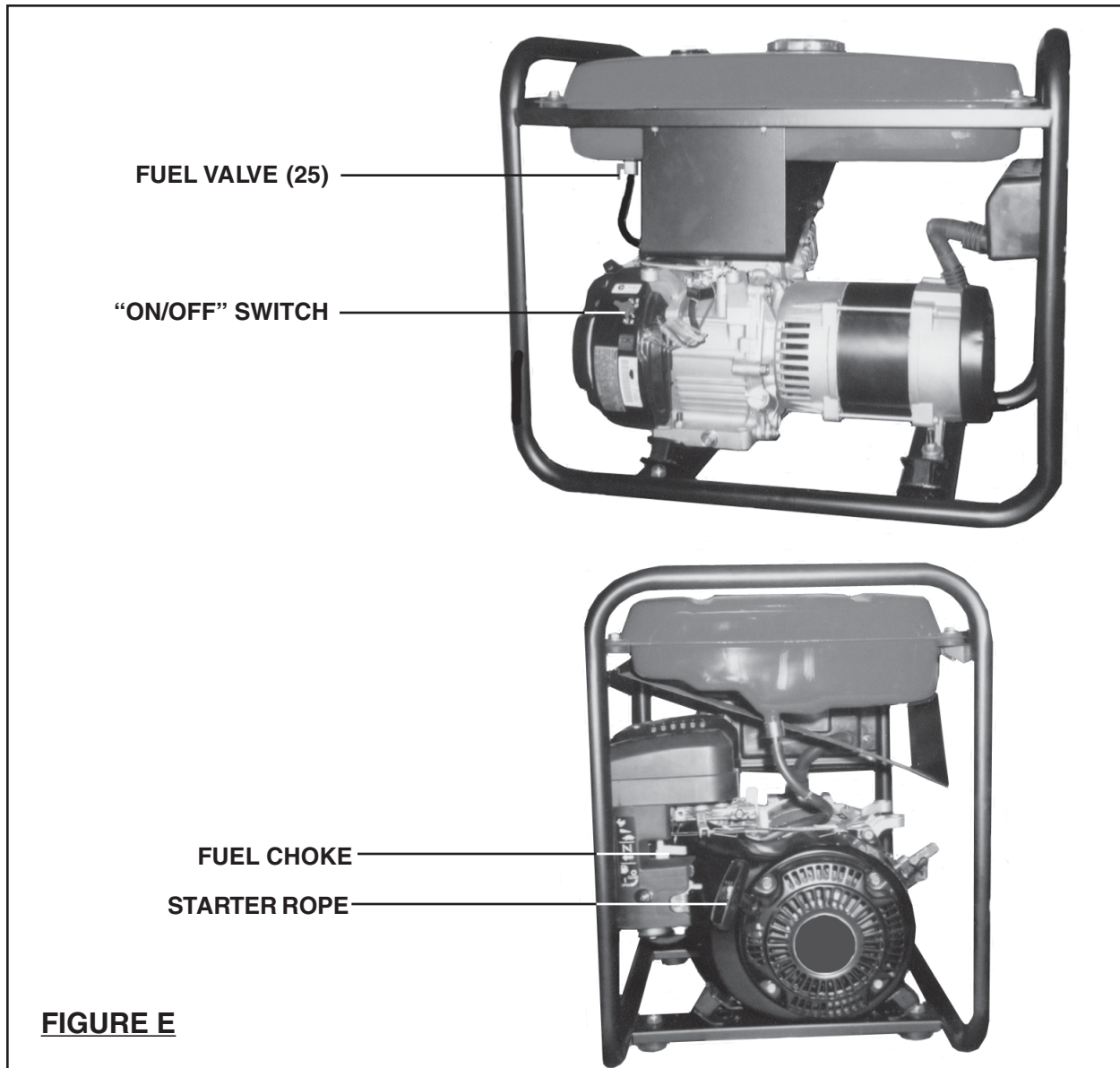

**FIGURE E**

***Powering Tools And Equipment:***

1. Prior to powering tools and equipment, make sure the Generator's rated voltage, wattage, and amperage capacity (120V/20 AMPs) is adequate to supply all electrical loads that the unit will power. If powering exceeds the Generator's capacity, it may be necessary to group one or more of the tools and/or equipment for connection to a separate generator.
2. Once the Generator is running, simply connect the Power Cords of 120 volt powered tools and equipment into the 120 volt Dual Outlets (35).  
**(See Figure F, next page.)**

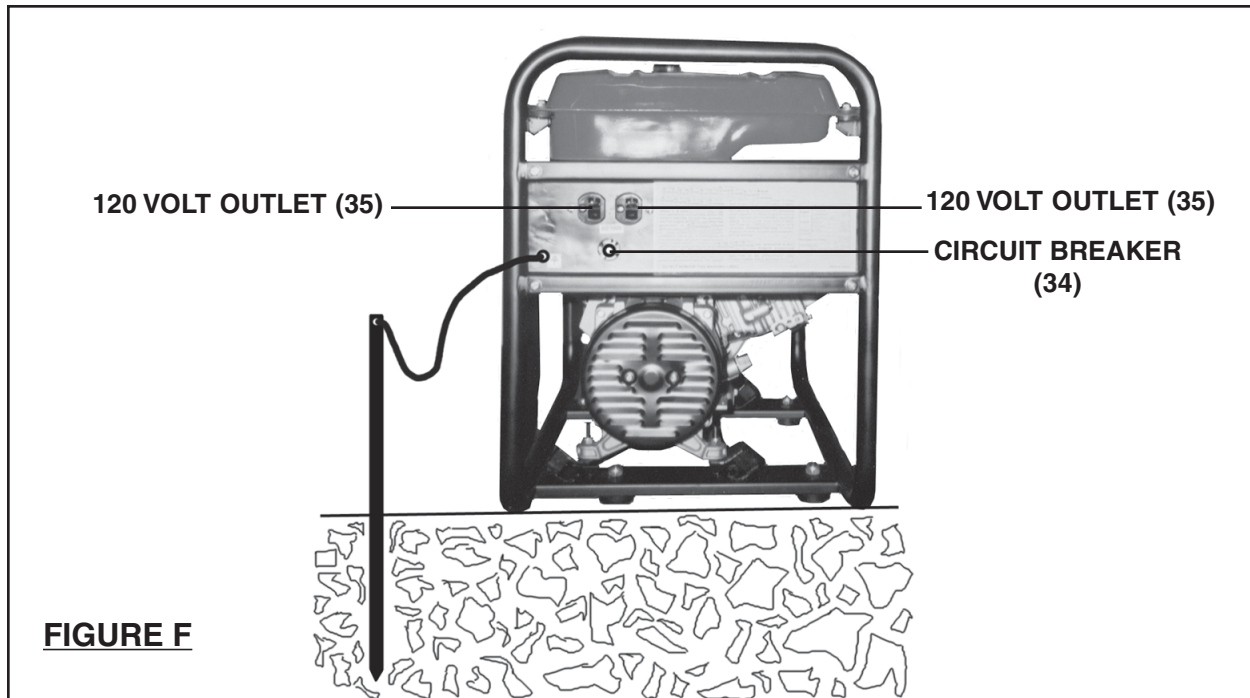

3. **NOTE:** The Generator features an AC Non-Fuse Circuit Breaker (34) to protect the AC circuit in case of an overload. Should an overload occur the Circuit Breaker will “trip”, causing the Generator to automatically shut down. In this case, refer to Step #1. Then, reset the circuitry system by depressing the Circuit Breaker. Restart the Generator and continue powering the remaining tools and equipment. **(See Figure F.)**
4. When finished using the Generator, turn the ON/OFF Switch to its “OFF” position to stop the Generator. **(See Figure E.)**
5. After the Engine and Generator have completely cooled, store the Generator in a safe, clean, dry location out of reach of children and other unauthorized people.

## INSPECTION, MAINTENANCE, AND CLEANING

1. **NOTE:** Preventative maintenance procedures and frequency will vary depending on the amount of Generator use. Refer to the *Engine manufacturer’s Operation, Maintenance, and Parts manual* (included) for detailed information regarding maintenance of the Engine.
2. **CAUTION!** Always make sure the ON/OFF Switch is in its “OFF” position. Disconnect the spark plug wire from the engine. And allow sufficient time for the Engine and Generator to completely cool before performing any inspection, maintenance, or cleaning.

3. **Before each use:** Inspect the general condition of the Generator. Check for loose screws, misalignment or binding of moving parts, cracked or broken parts, damaged electrical wiring, and any other condition that may affect its safe operation. If abnormal noise or vibration occurs, have the problem corrected before further use. **Do not use damaged equipment.**
4. **Before each use:** Check to make sure the Engine's oil level is adequate. Refer to the Engine manufacturer's Operation, Maintenance, and Parts Manual (included) for specific information.
5. **Prior to refilling the Fuel Tank:** Remove the Fuel Tank Cap (30) to expose the Filter (32). Remove the Filter and inspect it for an accumulation of dirt and debris. If necessary, clean the Filter using unleaded gasoline or a mild solvent. Then, replace the Filter. Fill the Fuel Tank (26) with unleaded gasoline, and replace the Fuel Tank Cap. **(See Figure G.)**
6. **Daily:** With a soft brush, cloth, or vacuum, remove all debris from the Generator. Then, use a premium quality, lightweight machine oil to lubricate all moving parts.

7.  **WARNING!**  
All maintenance, service, and repairs not listed in this manual are only to be attempted by a qualified technician.

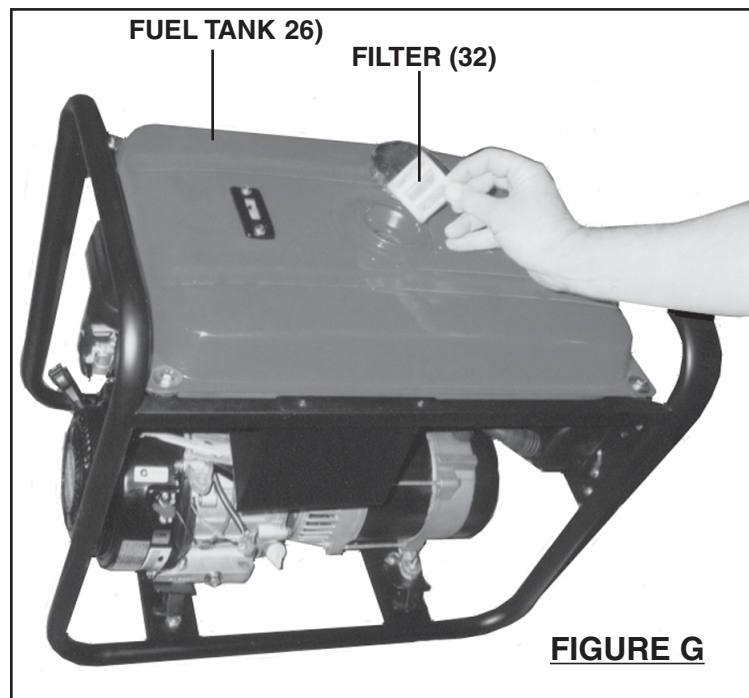



**PLEASE READ THE FOLLOWING CAREFULLY**

THE MANUFACTURER AND/OR DISTRIBUTOR HAS PROVIDED THE PARTS LIST AND ASSEMBLY DIAGRAM IN THIS MANUAL AS A REFERENCE TOOL ONLY. NEITHER THE MANUFACTURER OR DISTRIBUTOR MAKES ANY REPRESENTATION OR WARRANTY OF ANY KIND TO THE BUYER THAT HE OR SHE IS QUALIFIED TO MAKE ANY REPAIRS TO THE PRODUCT, OR THAT HE OR SHE IS QUALIFIED TO REPLACE ANY PARTS OF THE PRODUCT. IN FACT, THE MANUFACTURER AND/OR DISTRIBUTOR EXPRESSLY STATES THAT ALL REPAIRS AND PARTS REPLACEMENTS SHOULD BE UNDERTAKEN BY CERTIFIED AND LICENSED TECHNICIANS, AND NOT BY THE BUYER. THE BUYER ASSUMES ALL RISK AND LIABILITY ARISING OUT OF HIS OR HER REPAIRS TO THE ORIGINAL PRODUCT OR REPLACEMENT PARTS THERETO, OR ARISING OUT OF HIS OR HER INSTALLATION OF REPLACEMENT PARTS THERETO.

**PARTS LIST**

Part	Description	Qty.	Part	Description	Qty.
1	Connection Board	1	21	Bolt (M5)	4
2	Bolt (M6 x 130)	4	22	Heat Insulation Board	1
3	Bolt (M5 x 12)	2	23	Bolt (M6)	4
4	Cable Sheath	1	24	Bolt (M5 x 35)	4
5	Rear Cover	1	25	Fuel Valve	1
6	Bolt	2	26	Fuel Tank	1
7	Capacitor	1	27	Fuel Gauge	1
8	Alternator Back Cover	1	28	Bolt (M5 x 12)	2
9	Stator	1	29	Bolt (M6 x 25)	4
10	Bridge Combination	2	30	Fuel Tank Cap	1
11	Voltage Dependent Resistor	2	31	Seal Ring	1
12	Rotor	1	32	Filter	1
13	Hex Bolt (5/16"-24)	4	33	Bolt (M5)	4
14	Alternator Front Cover	1	34	Circuit Breaker	1
15	Shock Absorber Support	4	35	Outlet 20A/120V	2
16	Bolt (M10)	4	36	Bolt (5/16"-24 x 170)	1
17	Ground Connector	4	37	Bolt(M5x16)	2
18	Frame	1	38	Bolt(M5)	4
19	Bolt (M10)	4	39	Bolt(M5x25)	2
20	Shock Absorber	4			

**NOTE:**

Some parts are listed and shown for illustration purposes only,  
and are not available individually as replacement parts.

# ASSEMBLY DIAGRAM

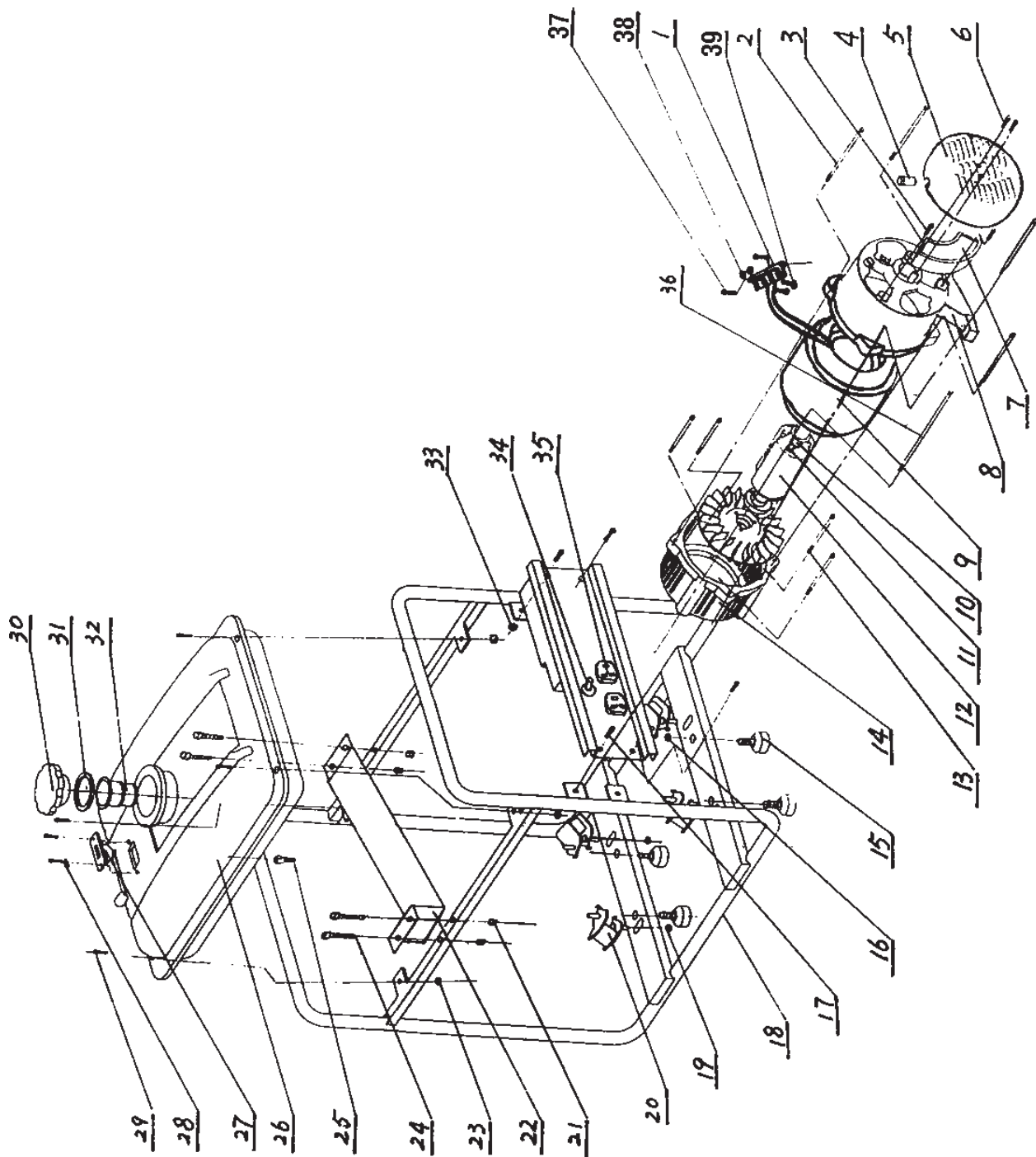

**NOTE:**

Some parts are listed and shown for illustration purposes only, and are not available individually as replacement parts.

# ELECTRICAL SCHEMATIC

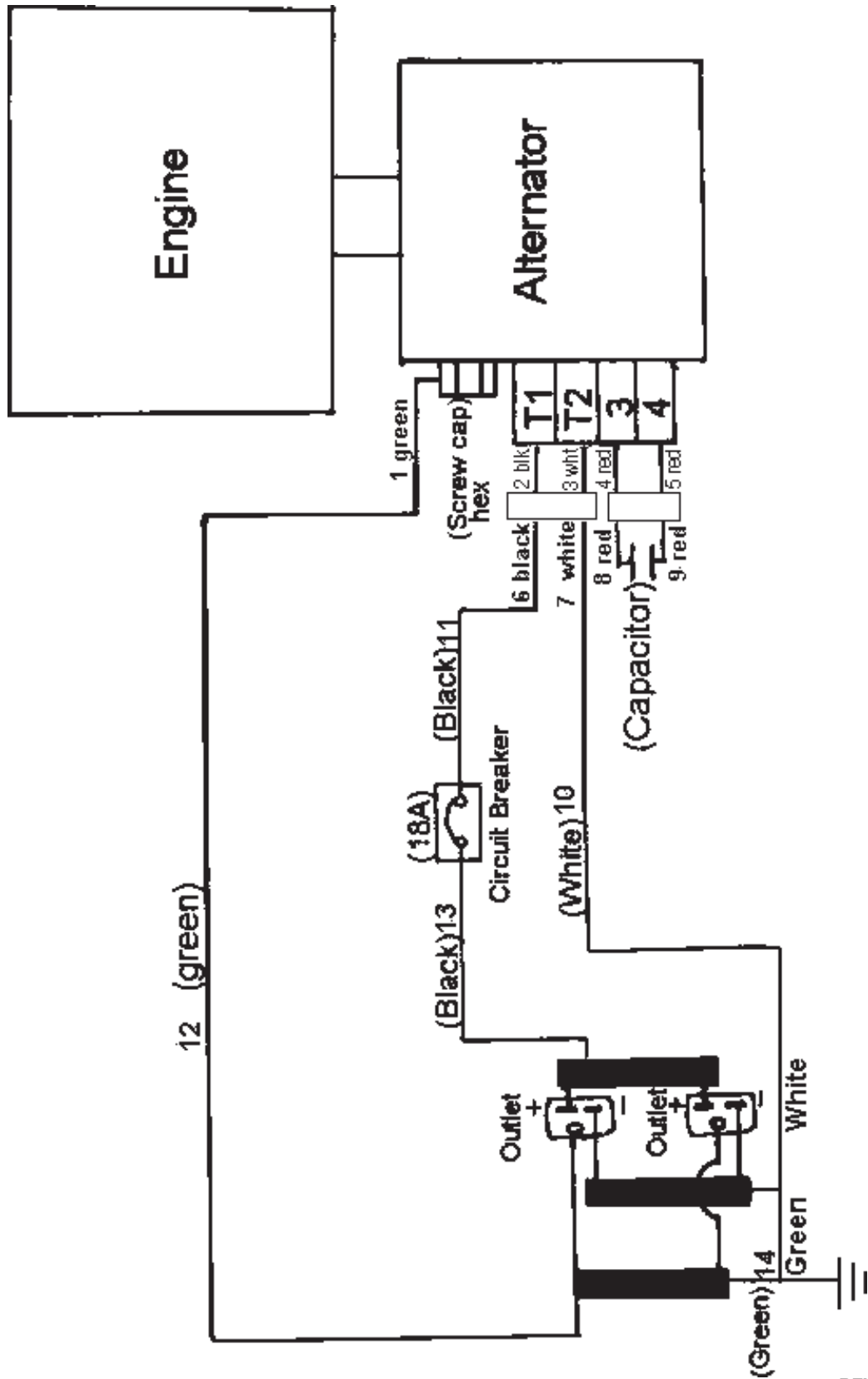

## Free Manuals Download Website

<http://myh66.com>

<http://usermanuals.us>

<http://www.somanuals.com>

<http://www.4manuals.cc>

<http://www.manual-lib.com>

<http://www.404manual.com>

<http://www.luxmanual.com>

<http://aubethermostatmanual.com>

Golf course search by state

<http://golfingnear.com>

Email search by domain

<http://emailbydomain.com>

Auto manuals search

<http://auto.somanuals.com>

TV manuals search

<http://tv.somanuals.com>