



# 2" OR 3" DIRTY WATER PUMP

Model **65322** or Model **65323**

## SET UP, OPERATING, AND SERVICING INSTRUCTIONS



### **⚠ DANGER**

Using an engine indoors **CAN KILL YOU IN MINUTES.**

Engine exhaust contains carbon monoxide. This is a poison you cannot see or smell.



**NEVER** use inside a home or garage, **EVEN IF** doors and windows are open.



Only use **OUTSIDE** and far away from windows, doors, and vents.

Distributed exclusively by Harbor Freight Tools®.

3491 Mission Oaks Blvd., Camarillo, CA 93011

Visit our website at: <http://www.harborfreight.com>



**Read this material before using this product.  
Failure to do so can result in serious injury.  
SAVE THIS MANUAL.**

Copyright© 2008 by Harbor Freight Tools®. All rights reserved. No portion of this manual or any artwork contained herein may be reproduced in any shape or form without the express written consent of Harbor Freight Tools. Diagrams within this manual may not be drawn proportionally. Due to continuing improvements, actual product may differ slightly from the product described herein. Tools required for assembly and service may not be included.

**For technical questions or replacement parts, please call 1-800-444-3353.**

# CONTENTS

Page #	Contents
1	Cover and Contact Information
2	Table of Contents
3 - 6	Important Safety Information
6	Pump Specifications
6-8	Unpacking and Set Up
7-9	Operating Instructions
7	Checking and Filling Engine Oil
8	Checking and Filling Fuel
8	Start Procedure
9	Break In Period
9	Pump Operation
10	Engine Controls and Indicators
11 - 12	Pre Operation Checks
12	Starting & Stopping the Engine
13	Technical Specifications
13 - 19	Servicing
13 - 14	Engine Oil Change
14	Air Filter Element Maintenance
14	Spark Plug Maintenance
15	Fuel Filter Replacement
15	Cleaning, Maintenance and Lube Schedule
16	Storage
17 - 18	Engine Troubleshooting
19	Pump Troubleshooting
19	Pump Parts List
20	Pump Assembly Diagram

Page #	Contents
21	Crankcase Assembly Diagram and Parts List
22	Crankcase Cover Assembly Diagram and Parts List
23	Cylinder Head and Cover Assembly Diagram and Parts List
24	Crankshaft, Piston and Connecting Rod Assembly Diagram and Parts List
25	Camshaft and Rocker Valve Assembly Diagram and Parts List
26	Carburetor Assembly Diagram and Parts List
27	Fuel Tank Assembly Diagram and Parts List
28	Air Cleaner Assembly Diagram and Parts List
29	Muffler Assembly Diagram and Parts List
30	Recoil Starter Assembly Diagram and Parts List
31	Regulator Control Assembly Diagram and Parts List
32	Flywheel Assembly Diagram and Parts List
33	Ignition Coil Assembly Diagram and Parts List
34	Wiring Diagram
35 - 36	Warranty

---

## SAVE THIS MANUAL

---

Keep this manual for the safety warnings and precautions, assembly, operating, inspection, maintenance and cleaning procedures. Write the product's serial number in the back of the manual near the assembly diagram (or month and year of purchase if product has no number). Keep this manual and the receipt in a safe and dry place for future reference.

---

## IMPORTANT SAFETY INFORMATION

---

In this manual, on the labeling, and all other information provided with this product:



This is the safety alert symbol. It is used to alert you to potential personal injury hazards. Obey all safety messages that follow this symbol to avoid possible injury or death.

### **DANGER**

**DANGER** indicates a hazardous situation which, if not avoided, will result in death or serious injury.

### **WARNING**

**WARNING** indicates a hazardous situation which, if not avoided, could result in death or serious injury.

### **CAUTION**

**CAUTION**, used with the safety alert symbol, indicates a hazardous situation which, if not avoided, could result in minor or moderate injury.

### **NOTICE**

**NOTICE** is used to address practices not related to personal injury.

### **CAUTION**

**CAUTION**, without the safety alert symbol, is used to address practices not related to personal injury.



**WARNING! Read all instructions. Failure to follow all instructions listed below may result in fire, serious injury and/or DEATH.**

The warnings and precautions discussed in this manual cannot cover all possible conditions and situations that may occur. It must be understood by the operator that common sense and caution are factors which cannot be built into this product, but must be supplied by the operator.

### **SAVE THESE INSTRUCTIONS**

### **SET UP PRECAUTIONS**

1. Gasoline fuel and fumes are flammable, and potentially explosive. Use proper fuel storage and handling procedures. Do not store fuel or other flammable materials nearby.
2. Have multiple ABC class fire extinguishers nearby.
3. Operation of this equipment may create sparks that can start fires around dry vegetation. A spark arrestor may be required. The operator should contact local fire agencies for laws or regulations relating to fire prevention requirements.
4. Set up and use only on a flat, level, well-ventilated surface.

5. Wear ANSI-approved safety goggles, heavy-duty work gloves, and dust mask/respirator during set up.
6. Use only oil and fuel recommended in the "Specifications" section of this manual.
4. Wear ANSI-approved safety goggles and hearing protection during use.
5. People with pacemakers should consult their physician(s) before use. Electromagnetic fields in close proximity to a heart pacemaker could cause pacemaker interference or pacemaker failure. Caution is necessary when near the engine's magneto or recoil starter.

## **OPERATING PRECAUTIONS**

1.  **CARBON MONOXIDE HAZARD**  
**Using an engine indoors CAN KILL YOU IN MINUTES.**

Engine exhaust contains carbon monoxide. This is a poison you cannot see or smell.

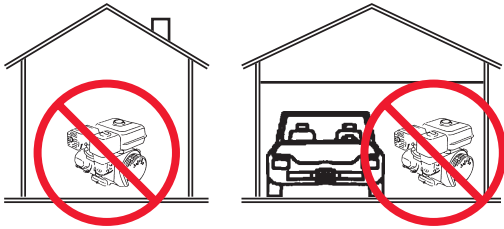

NEVER use inside a home or garage, EVEN IF doors and windows are open.

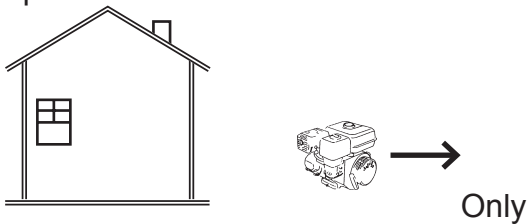

use OUTSIDE and far away from windows, doors, and vents.

2. Keep children away from the equipment, especially while it is operating.
3. Do not leave the equipment unattended when it is running. Turn off the equipment (and remove safety keys, if available) before leaving the work area.
7. Do not operate in explosive atmospheres, such as in the presence of flammable liquids, gases, or dust. Gasoline-powered engines may ignite the dust or fumes.
8. Stay alert, watch what you are doing and use common sense when operating this piece of equipment. Do not use this piece of equipment while tired or under the influence of drugs, alcohol or medication.
9. Do not overreach. Keep proper footing and balance at all times. This enables better control of the equipment in unexpected situations.
10. Use this equipment with both hands only. Using equipment with only one hand can easily result in loss of control.
11. Dress properly. Do not wear loose clothing or jewelry. Keep hair, clothing and gloves away from moving parts. Loose clothes, jewelry or long hair can be caught in moving parts.

12. Parts, especially exhaust system components, get very hot during use. Stay clear of hot parts.
13. Do not cover the engine or equipment during operation.
14. Keep the equipment, engine, and surrounding area clean at all times.
15. Use the equipment, accessories, etc., in accordance with these instructions and in the manner intended for the particular type of equipment, taking into account the working conditions and the work to be performed. Use of the equipment for operations different from those intended could result in a hazardous situation.
16. Do not operate the equipment with known leaks in the engine's fuel system.
17. This product contains or, when used, produces a chemical known to the State of California to cause cancer and birth defects or other reproductive harm. (California Health & Safety Code § 25249.5, *et seq.*)
18. When spills of fuel or oil occur, they must be cleaned up immediately. Dispose of fluids and cleaning materials as per any local, state, or federal codes and regulations. Store oil rags in a bottom-ventilated, covered, metal container.
19. Keep hands and feet away from moving parts. Do not reach over or across equipment while operating.
20. Before use, check for misalignment or binding of moving parts, breakage of parts, and any other condition that may affect the equipment's operation. **If damaged, have the equipment serviced before using.** Many accidents are caused by poorly maintained equipment.
21. Use the correct equipment for the application. Do not modify the equipment and do not use the equipment for a purpose for which it is not intended.

## **SERVICE PRECAUTIONS**

1. **Before service, maintenance, or cleaning:**
  - a. **Turn the engine switch to its "OFF" position.**
  - b. **Allow the engine to completely cool.**
  - c. **Then, remove the spark plug wire(s) from the spark plug(s).**
2. Keep all safety guards in place and in proper working order. Safety guards include muffler, air cleaner, mechanical guards, and heat shields, among other guards.
3. **Do not alter or adjust any part of the equipment or its engine that is sealed by the manufacturer or distributor. Only a qualified service technician may adjust parts that may increase or decrease governed engine speed.**
4. Wear ANSI-approved safety goggles, heavy-duty work gloves, and dust mask/respirator during service.
5. Maintain labels and nameplates on the equipment. These carry important information. If unreadable or missing, contact Harbor Freight Tools for a replacement.

6. Have the equipment serviced by a qualified repair person using only identical replacement parts. This will ensure that the safety of the equipment is maintained. Do not attempt any service or maintenance procedures not explained in this manual or any procedures that you are uncertain about your ability to perform safely or correctly.
7. Store equipment out of the reach of children.
8. Follow scheduled engine and equipment maintenance.
9. Refueling Precautions:
  - a. Do not smoke, or allow sparks, flames, or other sources of ignition around the equipment, especially when refuelling.
  - b. Do not refill the fuel tank while the engine is running or hot.
  - c. Do not fill fuel tank to the top. Leave a little room for the fuel to expand as needed.
  - d. Refuel in a well-ventilated area only.



## **SAVE THESE INSTRUCTIONS.**

## **PUMP SPECIFICATIONS**

Inlet / Outlet Diameter	Model 65322 = 3" Model 65323 = 2"
Maximum Flow in GPM (Gallons per Minute)	Model 65322 = 345 Model 65323 = 235
Maximum Lift Suction	Model 65322 = 26' Model 65323 = 23'
Maximum Head	Model 65322 = 85' Model 65323 = 82'
Anti-Reverse Flow	Rubberized Flap on Inlet Port

**Note:** Additional specifications found in the TECHNICAL ENGINE SPECIFICATIONS chart in this manual.

***The emission control system for this engine is warranted for standards set by the U.S. Environmental Protection Agency. For warranty information, refer to the last pages of this manual.***

At high altitudes, the engine's carburetor, governor (if so equipped), and any other parts that control the fuel-air ratio will need to be adjusted by a qualified mechanic to allow efficient high-altitude use and to prevent damage to the engine and any other devices used with this product.

## **UNPACKING**

When unpacking, check to make sure that the item is intact and undamaged. If any parts are missing or broken, please call Harbor Freight Tools at the number shown on the cover of this manual as soon as possible.

Included Accessories:

- a. Inlet and Outlet Pipes.
- b. Inlet Hose Basket Filter

---

## SET UP INSTRUCTIONS

---



Read the **ENTIRE IMPORTANT SAFETY INFORMATION** section at the beginning of this manual including all text under subheadings therein before set up or use of this product.

### **WARNING**

#### **TO PREVENT SERIOUS INJURY**

##### **FROM ACCIDENTAL STARTING:**

Turn the Power Switch of the equipment to its “OFF” position, wait for the engine to cool, and disconnect the spark plug wire(s) before assembling or making any adjustments to the equipment.

### **WARNING**

#### **TO PREVENT SERIOUS INJURY:**

Operate only with proper spark arrestor installed.

Operation of this equipment may create sparks that can start fires around dry vegetation.

A spark arrestor may be required.

The operator should contact local fire agencies for laws or regulations relating to fire prevention requirements.

**Note:** For additional information regarding the parts listed in the following pages, refer to the Assembly Diagram near the end of this manual.

### **Assembly**

1. Inlet and Outlet Pipes (12) must be attached prior to use. Additional inlet and outlet hoses and clamps (not

included) will be needed depending on the specifics of use.

2. Remove the Pipe Clamps (13) from both Inlet and Outlet Ports of the Pump Housing (10) by turning counterclockwise.
3. Place Pipe Clamp (13) over Inlet or Outlet Pipe (12). Position Inlet / Outlet Gasket (11) at Inlet or Outlet Port of the Pump Housing (10). Position Inlet or Outlet Pipe (12) at Inlet or Outlet Port, and secure in place by turning Pipe Clamp (13) clockwise. Hand tighten firmly. See **Pump Assembly Diagram** on page 20.

---

## OPERATING INSTRUCTIONS

---



Read the **ENTIRE IMPORTANT SAFETY INFORMATION** section at the beginning of this manual including all text under subheadings therein before set up or use of this product.

### **Starting the Engine**



Inspect engine and equipment looking for damaged, loose, and missing parts before set up and starting. If any problems are found, do not use equipment until fixed properly.

### **Checking and Filling Engine Oil**

**CAUTION!** Your Warranty is VOID if the engine's crankcase is not properly filled with oil before each use. Before each use, check the oil level. Do not run the engine with low or no engine oil. Running the engine with no or low engine oil WILL permanently damage the engine.

1. Wipe off dipstick area, remove dipstick and wipe it off with a clean rag.
2. Reinsert the dipstick (do not thread in) and remove it to check the oil level. The oil level should be between the high and low marks on the dipstick.
3. If the oil level is below the low mark add the appropriate type of oil until the oil level is between the high and the low marks.

**Oil type:**

32° F or above = SAE 10W30

Below 32° F = SAE 5W30

1. Replace the Oil Dipstick.

**CAUTION!** Do not run the engine with too little or too much oil. The engine will be permanently damaged.

**Checking and Filling Fuel**



**▲WARNING! TO PREVENT SERIOUS INJURY FROM FIRE:**

Fill the fuel tank in a well-ventilated area away from ignition sources. Do not smoke.

1. Check the fuel level before starting engine.
2. To fill the Fuel Tank, first wipe off the Fuel Tank Cap and the surrounding area.
3. Unscrew, and remove the Fuel Tank Cap.
4. Mix fuel stabilizer (not included) with 91 octane (or better) unleaded gasoline according to fuel stabilizer directions.

5. Fill the Fuel Tank to about 1 inch under the fill neck of the gasoline tank with the stabilized unleaded gasoline mixture.
6. Then replace the Fuel Tank Cap.

**Start Procedure**



**Before starting the engine:**

- a. Follow the Set Up Instructions to prepare the equipment.
- b. Inspect the equipment and engine.
- c. Fill the engine with the proper amount and type of fuel and oil.
- d. Read the Equipment Operation section that follows.

1. Turn the engine fuel valve to its "OPEN" position.
2. Turn the engine power switch to its ON or RUN position.
3. Then, turn the engine choke lever to its "CHOKE" position. Set the choke lever in the "RUN" position when starting a warm engine.
4. Grasp the starter handle, and pull slowly until resistance is felt. While holding the handle, allow the starter rope to rewind slowly. Then, pull the starter handle with a rapid, full arm stroke. Once again while holding the handle, allow the rope to rewind slowly. Repeat as necessary, until the engine starts.
5. After the engine starts and warms up, slowly move the choke lever to its "RUN" position.



6. **IMPORTANT:** Allow the engine to run at no load until warm (1-5 minutes) with no load after each start-up to allow the engine to stabilize.
3. Locate the pump as close to the water as possible. The pump should be on a firm, level surface.

### **Break-in Period**

1. Breaking-in the engine will help to ensure proper equipment and engine operation, and will extend the engine's lifespan. The warranty is void if the engine is not broken in properly. The first 20 hours of operation is the break-in period.
2. During the first 3 hours of use:
  - Do not apply a heavy load to the equipment.
  - Do not operate the engine at its maximum speed.
3. After the first 20 hours of use:
  - Change the engine oil.

Under normal operating conditions subsequent maintenance follows the schedule explained in the MAINTENANCE AND SERVICING section.
4. Position the input and output hoses as required. Place the input hose in the water to be removed, and output hose in an appropriate location to drain the water. Avoid sharp bends or kinks in the hoses.
5. Check that the pump is not jammed. Disconnect the spark plug wire on the engine, then slowly pull the Starter Handle to rotate the engine and pump. If the pump does not rotate freely, clear it before proceeding.
6. Prime the pump. To do this, remove Access Plug (14) from top of Pump Housing (10). Fill the pump with clean water, then replace the Priming Plug. **CAUTION: Never operate the pump dry, damage may result.**
7. Start the engine. The pump will start to operate as soon as the air is removed from the input hose.

### **Pump Operation**

1. Attach flexible input and output hoses (not included) to the Inlet and Outlet Pipes (12). Secure them with clamps, as the seal must be air and water tight. Attach the included accessory Basket Filter (18 and 19) to the input end of your flexible input hose.
2. **CAUTION:** Do not operate the pump without a basket filter on the input hose. This prevents large objects from being sucked into the Pump and/or damaging the Pump.
8. **STOP THE PUMP AS SOON AS WATER IS REMOVED. DO NOT ALLOW PUMP TO RUN DRY, DAMAGE TO THE PUMP WILL RESULT.**
9. Whenever possible, operate the pump for 2-3 minutes with clear water after pumping dirty water to clear it.
10. Drain the water from the pump and disconnect the flexible hoses.
11. To prevent accidents, turn off the engine and disconnect its spark plug wire after use. Wait for the engine to cool, clean external parts with clean cloth, then store the equipment out of children's reach according to the Storage instructions in this manual.

---

## ENGINE CONTROLS AND INDICATORS

---

Note: For clarity, pump not shown.

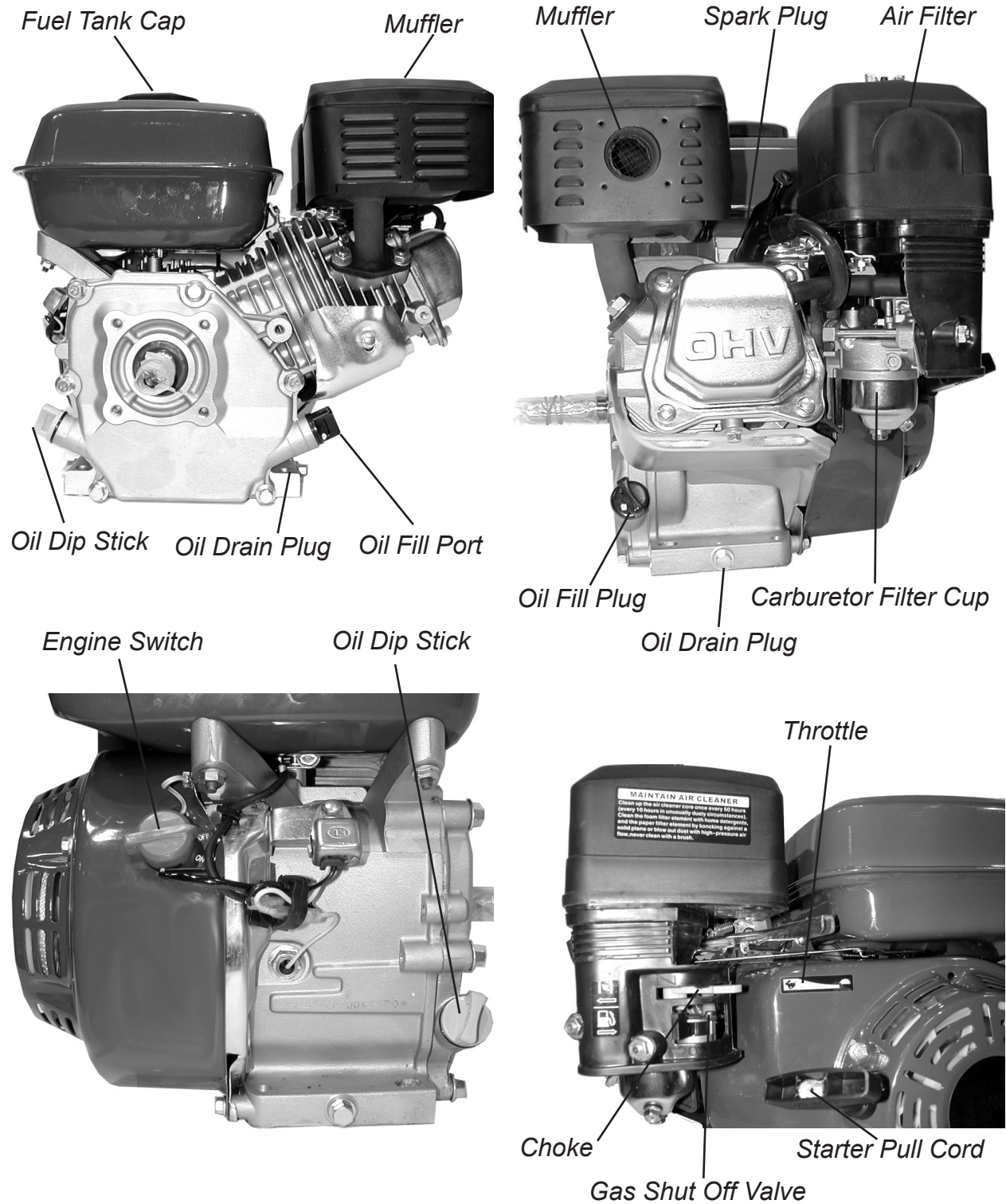

## **PRE-OPERATION CHECKS**

**Caution:** Failure to add oil to the Engine before use will damage the Engine and void the factory warranty. Engine oil is the key factor in engine performance. Do not use Engine oil with additives. Do not use two-stroke gasoline-oil. Using these products will shorten Engine life. See Specifications on page 6 for recommended oil type.

1. **Check that all mounting nuts and bolts are tight.**
2. **Check oil level** (See illustration below.) If needed, add oil and wipe Dip-

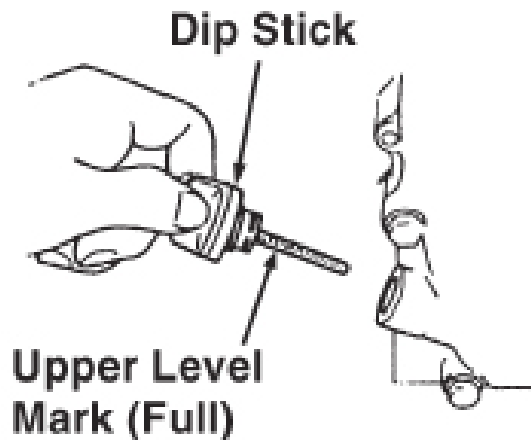

stick area. Unscrew the oil Dip Stick and wipe clean. Insert the Dip Stick back into the hole without screwing it in. Remove it again and check the oil level. Full is indicated by oil on the Upper Level mark.

3. If adding oil, use a siphon to avoid spilling the oil. Do not overfill.
4. When full, carefully screw the plastic Dip Stick back into the metal Engine crankcase to avoid stripping the plastic threads on the Dip Stick.

5. **Check Air Filter.** (See illustration below.) Unscrew Air Filter Wing Nut

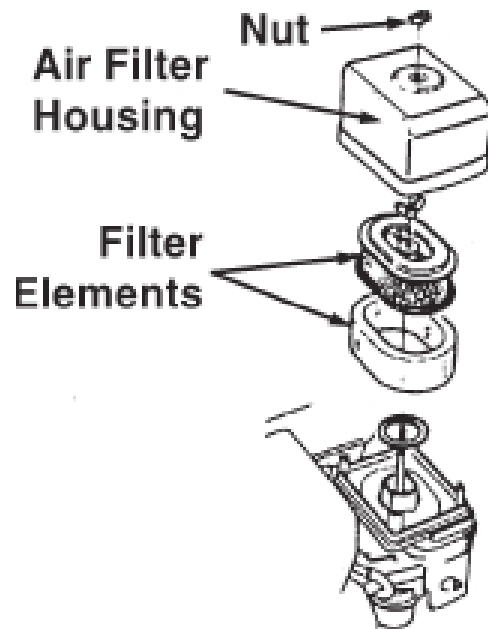

and remove the Air Filter Cover and Filter Elements. If dirty or dusty, clean (refer to the Maintenance Section).

6. **Caution:** To avoid damaging the Engine, never run it without the Air Filter Assembly attached.
7. **Check fuel level.** Remove the fuel Filter Cup, clean and replace it before filling.

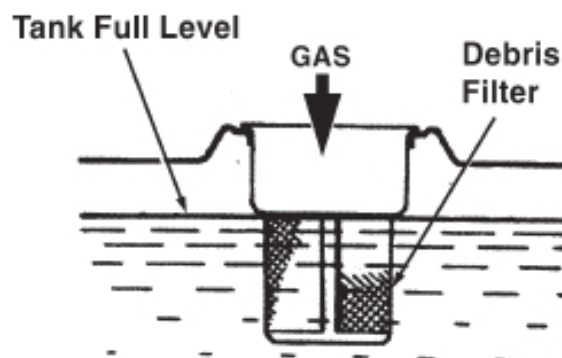

8. Fill the Fuel Tank, outdoors, with up to 0.95 of a gallon of unleaded gaso-



line containing at least 91 octane. Do not top-off tank, leave at least 1 inch of open space at top of tank.

9. Replace Fuel Cap. Hand tighten by turning clockwise.
10. Clean up any spilled gas with a dry cloth.



**Fire Hazard! Do not fill Gas Tank when the Engine is running, or near a pilot light or open flame or when hot. Do not smoke. Do not operate if gasoline has been spilled. Clean spilled gasoline before starting the engine.**

### Starting the Engine

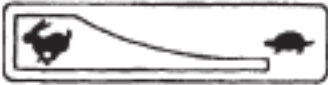
1. During this procedure, it may be helpful to refer to the photos of the Engine Controls on page 10.
2. Push the Gas Valve to the open (right) position. 
3. Close the Choke by pulling it to the left. 
4. Note: If the Engine is already hot, it is not necessary to close the Choke.
5. Push the Throttle Lever to the slow (right) position, then move it back slightly. 
6. Turn the Engine Switch to the On position.
7. Gently pull the Pull Cord Handle until it engages. Then pull it hard and all

the way out. Slowly guide the Pull Cord back into the starter. The Engine should start. Try again if it does not start. Refer to the Troubleshooting section if problems persist. Let the engine run for five minutes to warm up.

8. Push the Choke to the right 
9. Push the Throttle Lever to the fast position (left).

### Stopping the Engine

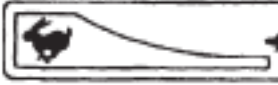
1. Push the Throttle Lever to the slow (right) position. 
2. Turn the Engine Switch to the Off position.
3. Push the Gas Valve to the closed (left) position.

## TECHNICAL SPECIFICATIONS

Engine Type	6.5 HP, OHV, 4 Stroke, Gas Engine	
Bore x Stroke	68 x 54 mm	
Starter Type	Manual Recoil Pull Type	
Ignition	Electronic Ignition	
Displacement	196cc	
Cooling System	Air Cooled	
Low Oil Shutdown	Yes	
Inlet/Outlet Pipe Outside Diameter	2.5" (Inlet)/3" (Outlet)	
Driveshaft Type	Horizontal 3/4" straight. 3/16" Keyed Shaft with Ball Bearings	
Driveshaft Rotation	Counterclockwise (facing shaft). Length: 2-1/4". Central Thread: 5/16"-24 TPI	
Fuel	Type	91+ octane unleaded gasoline
	Capacity	0.95 Gallons (3.6 Liters)
Engine Oil	Type	SAE 10W30 above 32° F SAE 5W30 at 32° F or below
	Capacity	.5 Quarts (0.5 liters)
Spark Plug	Type	BP6ES, BPR6ES (NGK), or NH SPLD F6RTC U
	Gap	0.7 - 0.8 mm gap
Valve Clearance	Intake	Cold Engine: 0.15+/- 0.02mm
	Exhaust	Cold Engine: 0.20+/- 0.02mm
Distributor Timing	Opening Closing	Intake: BTDC 10° Exhaust: ABDC 20°
Speed	Idle	1700 ± 150 RPM
	Maximum	3600 RPM

***The emission control system for this engine is warranted for standards set by the U.S. Environmental Protection Agency. For warranty information, refer to the last pages of this manual.***

## SERVICING

**⚠ WARNING** TO PREVENT SERIOUS INJURY FROM ACCIDENTAL STARTING:  
Turn the Power Switch of the equipment to its "OFF" position, wait for the engine to cool, and disconnect the spark plug wire(s) before performing any inspection, maintenance, or cleaning procedures.

**⚠ WARNING** TO PREVENT SERIOUS INJURY FROM EQUIPMENT FAILURE:  
Do not use damaged equipment. If abnormal noise, vibration, or excess smoking occurs, have the problem corrected before further use.

### Maintenance Procedures

**⚠** Many maintenance procedures, including those not detailed in this manual, will need to be performed by a qualified technician for safety. If you have any doubts about your ability to safely service the equipment or engine, have a qualified technician service the equipment instead.

**Note:** Warranty is void if proper maintenance and servicing procedures are not followed.

#### Engine Oil Change

**⚠ CAUTION!** Oil is very hot during operation and can cause burns. Wait for engine to cool before changing oil.

1. Place a drain pan (not included) underneath the crankcase's drain plug.
2. Remove the Dip Stick and Oil Drain Plug and, if possible, tilt the crankcase slightly to help drain the oil out. Recycle used oil.
3. Replace the Oil Drain Plug and gasket and tighten it.
4. Remove the cap from the Oil Fill Port. Using a siphon, refill the oil to the proper level. Replace the cap on the Oil Fill Port.
5. Recheck the oil level, using the dipstick. Add or remove oil if necessary. Do not operate the engine with too much or too little oil.
6. Inspect before operation.

#### **Air Filter Element Maintenance**

1. Wipe off the air cleaner cover.
2. The air cleaner cover is held in place by a wing nut or clamps. Remove it.
3. Remove the air filter element.
4. **Cleaning:**
  - a. For "paper" filter elements:  
To prevent injury from dust and debris, wear ANSI-approved safety goggles, NIOSH-approved dust mask/respirator, and heavy-duty work gloves. In a well-ventilated area away from bystanders, use pressurized air to blow dust out of the air filter from the side opposite the filter's normal air flow (the "clean" side of the filter).  
If this does not get the filter reasonably clean, replace it.
  - b. For foam filter elements:  
Wash the element in warm water

and mild detergent several times. Rinse. Squeeze out excess water and allow it to dry completely. Soak the filter in lightweight oil briefly, then squeeze out the excess oil.

4. Install the new filter or the cleaned filter. Secure the Air Cleaner Cover before use.

#### **Spark Plug Maintenance**

1. Disconnect spark plug wire from end of plug. Clean out debris from around spark plug.
2. Using a spark plug wrench, remove the spark plug.
3. Inspect the spark plug:  
If the electrode is oily, clean it using a clean, dry rag.  
If the electrode has deposits on it, polish it using emery paper.  
If the white insulator is cracked or chipped, the spark plug needs to be replaced.
4. When installing a new spark plug, adjust the plug's gap to the specification on the Technical specification chart (page 14). Do not pry against the electrode or the insulator, the spark plug can be damaged.
5. Install the new spark plug or the cleaned spark plug into the engine.  
Gasket-style: Finger-tighten until the gasket contacts the cylinder head, then about 1/2-2/3 turn more.  
Non-gasket-style: Finger-tighten until the plug contacts the head, then about 1/16 turn more.
6. Apply dielectric spark plug cap protector to the end of the spark plug and reattach the wire securely.

## Fuel Filter Replacement



### **▲WARNING! TO PREVENT SERIOUS INJURY FROM FIRE:**

Replace the fuel filter in a well-ventilated area away from ignition sources. Do not smoke.

1. Wait for engine to cool completely before proceeding.
2. Wear protective gear including, ANSI-approved safety goggles, NIOSH-approved dust mask/respirator, and nitrile gloves.
3. Close fuel valve leading from gas tank completely.
4. Take note of the fuel filter's orientation.
5. Place a suitable container under the fuel filter.
6. Disconnect the fuel lines leading to and from the fuel filter and allow fuel to drain onto the container.
7. Install new fuel filter in the same orientation. Make sure to properly secure both fuel lines.
8. Clean up and properly dispose of all fuel.
9. Wait for at least one hour before use to allow all residual fuel vapors to dissipate. **To prevent FIRE, do not start the engine while the smell of fuel hangs in the air.** Remember to open the fuel valve before restarting the engine. It may take a little longer than usual to start the engine because the fuel needs to refill the fuel line and new filter.

## Cleaning, Maintenance, and Lubrication Schedule

**Note:** This maintenance schedule is intended solely as a general guide. If performance decreases or if equipment operates unusually, check systems immediately. The maintenance needs of each piece of equipment will differ depending on factors such as duty cycle, temperature, air quality, fuel quality, and other factors.

**Note:** These procedures are in addition to the regular checks and maintenance explained as part of the regular operation of the engine and equipment.

### After Initial 20 Operation Hour Period:

- a. Change engine oil.

### Every 25 Operation Hours Thereafter:

- a. Clean/replace air filter element.
- b. Inspect/clean spark plug.

### Every 50 Operation Hours:

- a. Change engine oil.
- b. Replace fuel filter (if equipped).

### Every 100 Operation Hours:

- a. Replace spark plug.
- b. Replace air filter element.

**Note:** All maintenance procedures scheduled for 25, 50, and 100 operation hours should be performed at least yearly.

### Every 300 Operation Hours:

- a. Clean fuel tank and carburetor.
- b. Clean carbon build-up from combustion chamber.

---

## **STORAGE**

---

### **Engine Storage Preparation**

1. Wait for engine to cool, then clean engine with clean cloth.
2. When the equipment is to remain idle for longer than 20 days, prepare the engine for storage as follows:
  - a. Change engine oil and empty fuel tank.
  - b. Either leave fuel tank empty or refill fuel tank with fresh unleaded gasoline mixed with a fuel stabilizer intended for long term engine storage (not included). After filling, run engine for about 3-5 minutes to circulate the treated gasoline through the carburetor. Wait for engine to cool before proceeding.
  - c. Clean out area around spark plug. Remove spark plug and pour one tablespoon of engine oil into cylinder through spark plug hole.
  - d. Reinstall spark plug, but leave spark plug wire disconnected.
  - e. Pull recoil starter to distribute oil in cylinder. Stop after one or two revolutions when you feel the piston start the compression stroke (when you start to feel resistance).
3. Apply a thin coat of rust preventive oil to all uncoated metal parts.
4. Cover and store in a dry, well-ventilated area out of reach of children.
5. Before starting the engine after storage, keep in mind that untreated gasoline will deteriorate quickly. Drain the fuel tank and filter, and change to fresh fuel if untreated gasoline has been sitting for a month, if treated

gasoline has been sitting beyond the fuel stabilizer's recommended time period, or if the engine does not start properly.

### **Pump Storage Preparation**

1. Be sure the pump has been drained. Remove the Access Plug (15) on the bottom of the Pump Housing (10). Allow the water to drain, then replace the plug.
2. Check the pump for any damage before storage. Wipe with a clean cloth.



## Engine Troubleshooting

Problem	Possible Causes	Probable Solutions
<b>Engine will not start</b>	<p>FUEL RELATED:</p> <ol style="list-style-type: none"> <li>1. No fuel in tank or fuel valve closed.</li> <li>2. Choke not in start position, especially with cold engine.</li> <li>3. Low quality or deteriorated, old gasoline.</li> <li>4. Carburetor not primed.</li> <li>5. Dirty fuel passageways blocking fuel flow.</li> <li>6. Carburetor needle stuck. Fuel can be smelled in the air.</li> <li>7. Too much fuel in chamber. This can be caused by the carburetor needle sticking.</li> </ol>	<p>FUEL RELATED:</p> <ol style="list-style-type: none"> <li>1. Fill fuel tank and open fuel valve.</li> <li>2. Move choke to start position if engine is cold.</li> <li>3. Use only fresh 89+ octane unleaded gasoline.</li> <li>4. Prime carburetor by pressing priming bulb specified number of times (if equipped).</li> <li>5. Clean out passageways using fuel additive. Heavy deposits may require further cleaning.</li> <li>6. <b>Gently</b> tap side of carburetor float chamber with screwdriver handle.</li> <li>7. Turn choke to run position. Remove spark plug and pull the start handle several times to air out the chamber. Reinstall spark plug and set choke to start position.</li> </ol>
	<p>IGNITION (SPARK) RELATED:</p> <ol style="list-style-type: none"> <li>1. Spark plug wire not connected securely.</li> <li>2. Spark plug electrode wet or dirty.</li> <li>3. Incorrect spark plug gap.</li> <li>4. Spark plug wire or spark plug broken.</li> <li>5. Incorrect spark timing or faulty ignition system.</li> </ol>	<p>IGNITION (SPARK) RELATED:</p> <ol style="list-style-type: none"> <li>1. Connect spark plug wire properly.</li> <li>2. Clean spark plug.</li> <li>3. Correct spark plug gap.</li> <li>4. Replace spark plug wire and/or spark plug.</li> <li>5. Have qualified technician diagnose/repair ignition system.</li> </ol>
	<p>COMPRESSION RELATED:</p> <ol style="list-style-type: none"> <li>1. Cylinder not lubricated. Problem after long storage periods.</li> <li>2. Loose or broken spark plug. (Hissing noise will occur when trying to start.)</li> <li>3. Loose cylinder head or damaged head gasket. (Hissing noise will occur when trying to start.)</li> <li>4. Engine valves or tappets misadjusted or stuck.</li> </ol>	<p>COMPRESSION RELATED:</p> <ol style="list-style-type: none"> <li>1. Pour tablespoon of oil into spark plug hole. Crank engine a few times and try to start again.</li> <li>2. Tighten spark plug. If that does not work, replace spark plug. If problem persists, may have head gasket problem, see item below.</li> <li>3. Tighten head. If that does not remedy problem, replace head gasket.</li> <li>4. Adjust valve clearance. If that does not work, clean or replace valves/tappets.</li> </ol>



**Follow all safety precautions whenever diagnosing or servicing the equipment or engine.**

<b>Engine Troubleshooting</b>		
<b>Problem</b>	<b>Possible Causes</b>	<b>Probable Solutions</b>
<b>Engine misfires</b>	<ol style="list-style-type: none"> <li>1. Spark plug wire loose.</li> <li>2. Incorrect spark plug gap or damaged spark plug.</li> <li>3. Defective spark plug wire.</li> <li>4. Old or low quality gasoline.</li> <li>5. Incorrect compression.</li> </ol>	<ol style="list-style-type: none"> <li>1. Check wire connections.</li> <li>2. Re-gap or replace spark plug.</li> <li>3. Replace spark plug wire.</li> <li>4. Use only fresh 89+ octane unleaded gasoline.</li> <li>5. Diagnose and repair compression. (Use <b>Engine will not start: COMPRESSION RELATED</b> section.)</li> </ol>
<b>Engine stops suddenly</b>	<ol style="list-style-type: none"> <li>1. Low oil shutdown.</li> <li>2. Fuel tank empty or full of impure or low quality gasoline.</li> <li>3. Defective fuel tank cap creating vacuum, preventing proper fuel flow.</li> <li>4. Improper idle speed.</li> <li>5. Faulty magneto, incorrect timing, or clogged carburetor.</li> </ol>	<ol style="list-style-type: none"> <li>1. Fill engine oil to proper level. Check engine oil before EVERY use.</li> <li>2. Fill fuel tank with fresh 89+ octane unleaded gasoline.</li> <li>3. Test/replace fuel tank cap.</li> <li>4. Properly adjust idle speed.</li> <li>5. Have qualified technician diagnose and service engine.</li> </ol>
<b>Engine knocks</b>	<ol style="list-style-type: none"> <li>1. Old or low quality gasoline.</li> <li>2. Engine overloaded.</li> <li>3. Incorrect spark timing, deposit buildup, worn engine, or other mechanical problems.</li> </ol>	<ol style="list-style-type: none"> <li>1. Fill fuel tank with fresh 89+ octane unleaded gasoline.</li> <li>2. Do not exceed equipment's load rating.</li> <li>3. Have qualified technician diagnose and service engine.</li> </ol>
<b>Engine backfires</b>	<ol style="list-style-type: none"> <li>1. Impure or low quality gasoline.</li> <li>2. Engine too cold.</li> <li>3. Choke not open after engine warm.</li> <li>4. Engine not properly adjusted for high altitude operation.</li> <li>5. Intake valve stuck, choke stuck, incorrect timing, clogged carburetor, or overheated engine.</li> </ol>	<ol style="list-style-type: none"> <li>1. Fill fuel tank with fresh 89+ octane unleaded gasoline.</li> <li>2. Use cold weather fuel and oil additives to prevent backfiring.</li> <li>3. Move choke to run position after engine warms up.</li> <li>4. Qualified technician must adjust engine at altitudes greater than 5,000 feet above sea level.</li> <li>5. Have qualified technician diagnose and service engine.</li> </ol>



**Follow all safety precautions whenever diagnosing or servicing the equipment or engine.**

## Pump Troubleshooting

<b>Problem</b>	<b>Possible Causes</b>	<b>Probable Solutions</b>
Pump fails to prime or low output	<ol style="list-style-type: none"> <li>1. Air leaks in flexible hoses or fittings.</li> <li>2. Air Leak at Shaft Seal (3).</li> <li>3. Input basket filter not submerged.</li> <li>4. Input basket filter clogged or buried.</li> <li>5. Pump not primed.</li> <li>6. Collapsed input hose.</li> <li>7. Pump Impeller (5) damaged.</li> </ol>	<ol style="list-style-type: none"> <li>1. Repair any air leaks.</li> <li>2. Repair or replace shaft Seal.</li> <li>3. Submerge input basket filter.</li> <li>4. Clear input basket.</li> <li>5. Prime pump.</li> <li>6. Check and clear input hose.</li> <li>7. Replace Impeller.</li> </ol>
Engine stops suddenly	<ol style="list-style-type: none"> <li>1. Large object jams impeller.</li> </ol>	<ol style="list-style-type: none"> <li>1. Clear impeller. Repair or replace input basket filter.</li> </ol>

<b>PUMP PARTS LIST</b>		
<b>Part</b>	<b>Description</b>	<b>Q'ty</b>
1	Pump Cover	1
2	Spring Washer	4
3	Shaft Seal	1
4	Bolt m8 x 35	4
5	Impeller	1
6	O-Ring	1
7	Impeller Casing	1
8	O-Ring	1
9	Check Valve	1
10	Pump Housing	1
11	Input / Output Gaskets	2
12	Input / Output Pipes	2

<b>PUMP PARTS LIST</b>		
<b>Part</b>	<b>Description</b>	<b>Q'ty</b>
13	Pipe Clamp	2
14	Access Plug	2
15	Access Plug Gasket	2
16	O-Ring	6
17	T-Bolt	6
18	Basket Filter Connecting Pipe	1
19	Basket Filter	1
20	Frame	1
21	Engine	1
22	Flange Bolt	6
23	Flange Nut	6
24	Rubber Shock Absorber	2

### PLEASE READ THE FOLLOWING CAREFULLY

THE MANUFACTURER AND/OR DISTRIBUTOR HAS PROVIDED THE PARTS LIST AND ASSEMBLY DIAGRAM IN THIS MANUAL AS A REFERENCE TOOL ONLY. NEITHER THE MANUFACTURER OR DISTRIBUTOR MAKES ANY REPRESENTATION OR WARRANTY OF ANY KIND TO THE BUYER THAT HE OR SHE IS QUALIFIED TO MAKE ANY REPAIRS TO THE PRODUCT, OR THAT HE OR SHE IS QUALIFIED TO REPLACE ANY PARTS OF THE PRODUCT. IN FACT, THE MANUFACTURER AND/OR DISTRIBUTOR EXPRESSLY STATES THAT ALL REPAIRS AND PARTS REPLACEMENTS SHOULD BE UNDERTAKEN BY CERTIFIED AND LICENSED TECHNICIANS, AND NOT BY THE BUYER. THE BUYER ASSUMES ALL RISK AND LIABILITY ARISING OUT OF HIS OR HER REPAIRS TO THE ORIGINAL PRODUCT OR REPLACEMENT PARTS THERETO, OR ARISING OUT OF HIS OR HER INSTALLATION OF REPLACEMENT PARTS THERETO.

# PUMP ASSEMBLY DIAGRAM

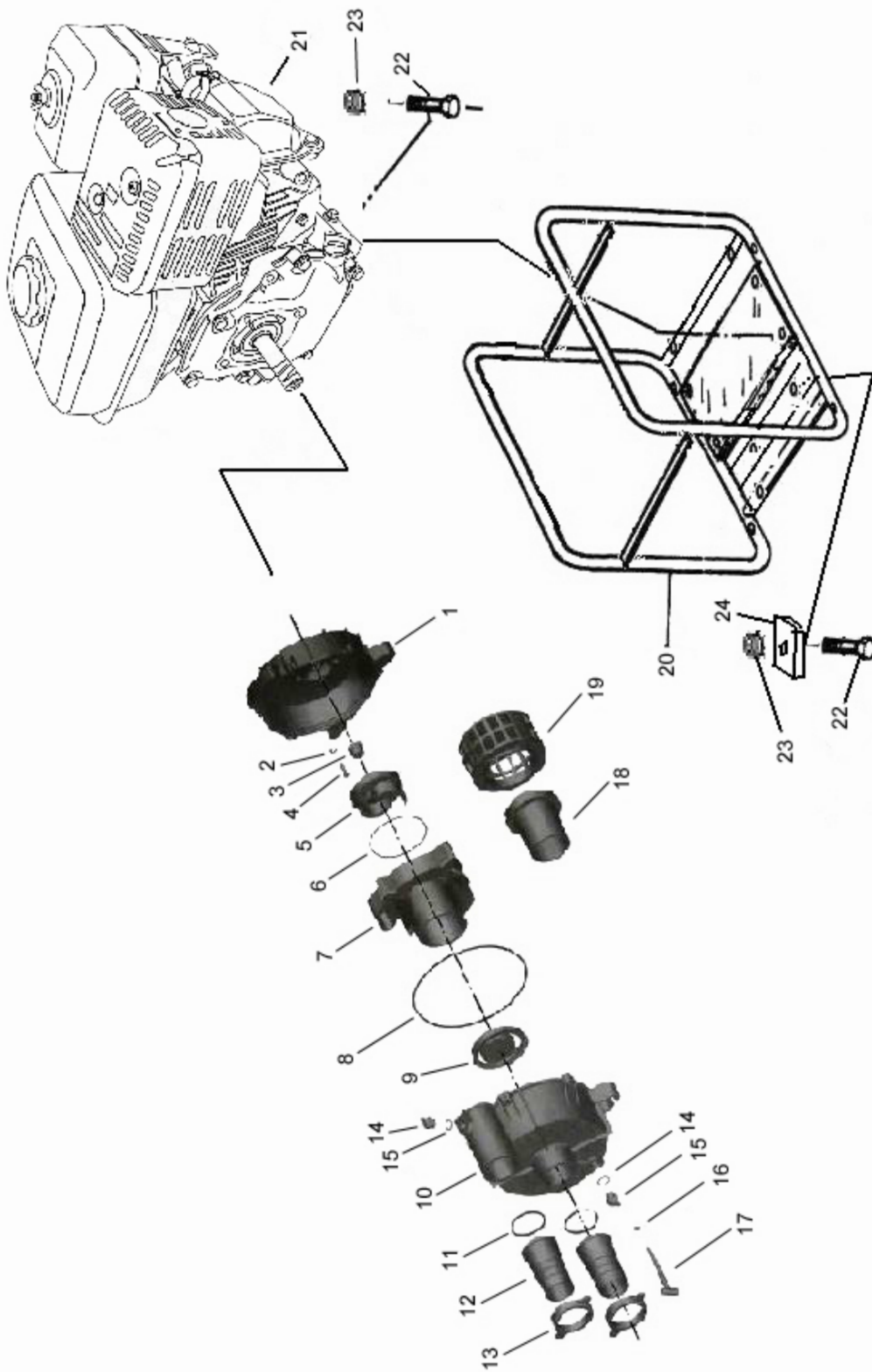

## CRANKCASE ASSEMBLY DIAGRAM

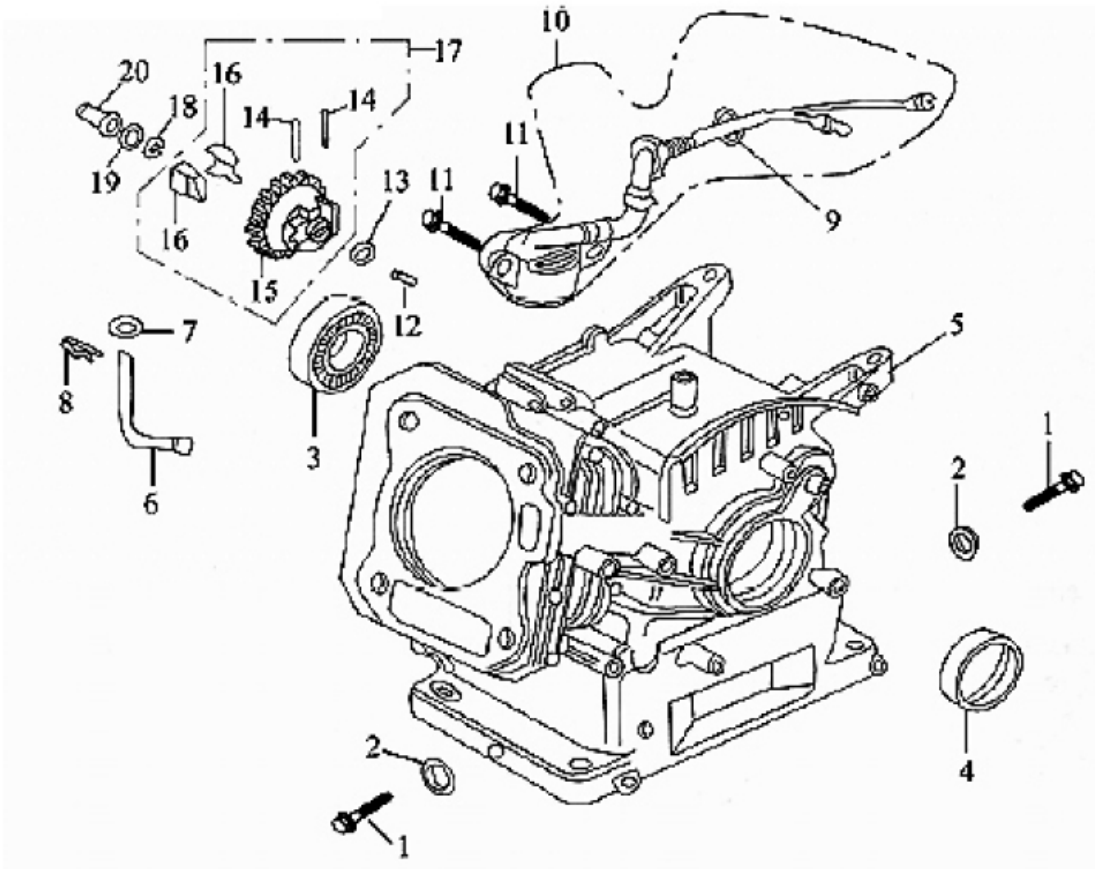

Note: When ordering parts from this list, specify: Parts List A, CRANKCASE ASSEMBLY, and the Item Number from the table below.

Part #	Description	Qty.
1a	Dipstick / Drain Plug	2
2a	O-Ring	2
3a	Bearing 6205	1
4a	Crankshaft Oil Seal	1
5a	Crankcase	1
6a	Regulator Sway Bar	1
7a	Washer	2
8a	Split Pin	1
9a	Nut m10	1
10a	Oil Sensor	1

Part #	Description	Qty.
11a	Bolt m6 x 14	2
12a	Regulating Shaft	1
13a	Drive Gear Washer	1
14a	Pin	2
15a	Regulator Drive Gear	1
16a	Fly Block	2
17a	Regulator Drive Gear Assembly	1
18a	Snap Ring	1
19a	Washer	2
20a	Sliding Sleeve	2

NOTE: Some parts in this and other parts lists in this manual are shown for illustration purposes only and may not be available individually as replacement parts.

## CRANKCASE COVER ASSEMBLY DIAGRAM

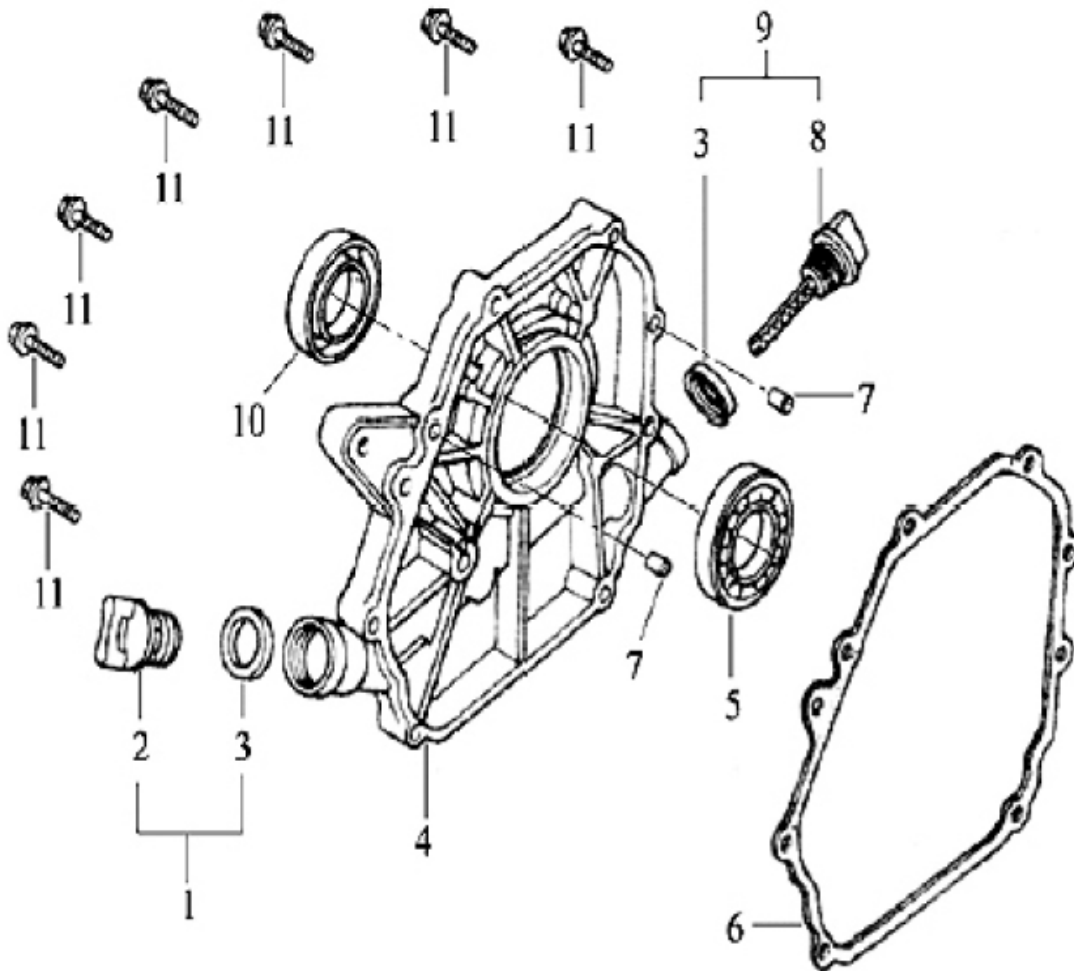

Note: When ordering parts from this list, specify: Parts List B, CRANKCASE COVER ASSEMBLY, and the Item Number from the table below.

Part #	Description	QTY
1b	Oil Fill Plug with Seal	1
2b	Oil Fill Plug	1
3b	Oil Plug Seal	2
4b	Crankcase Cover	1
5b	Bearing, 6250	1
6b	Crankcase Cover Gasket	1

Part #	Description	QTY
7b	Set Pin	2
8b	Oil Dipstick	1
9b	Oil Dipstick with Seal	1
10b	Crankshaft Oil Seal	1
11b	Bolt m8 x 32	7

## CYLINDER HEAD AND COVER ASSEMBLY DIAGRAM

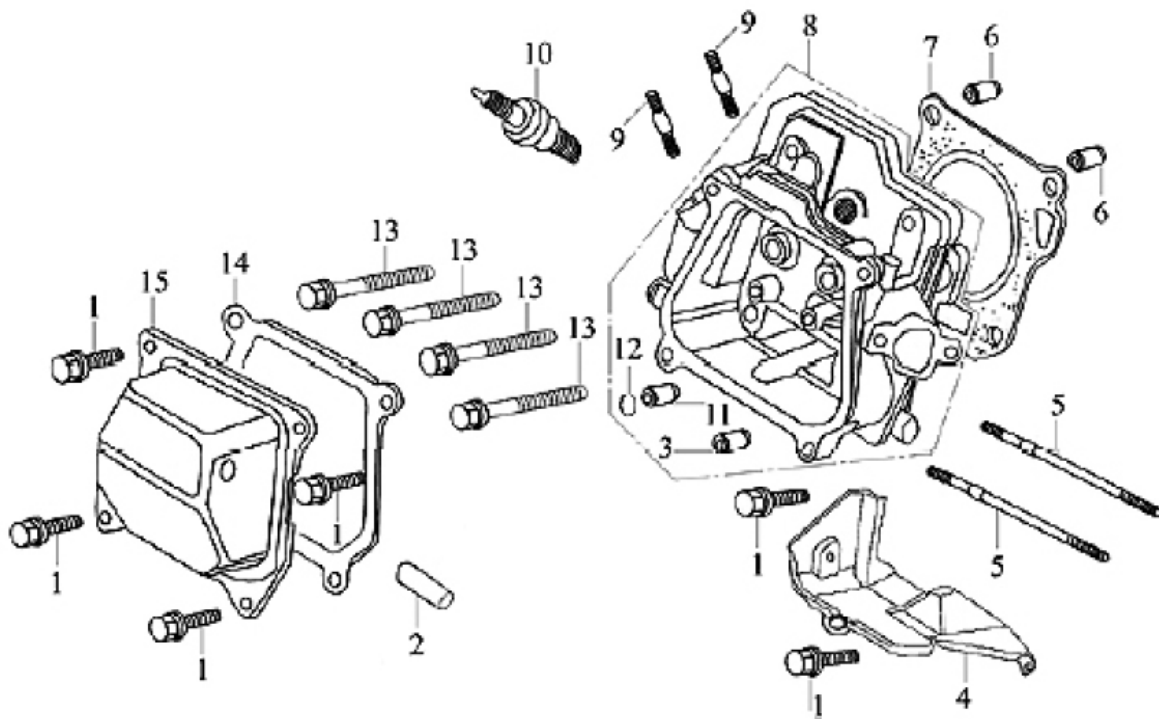

Note: When ordering parts from this list, specify: Parts List C, CYLINDER HEAD AND COVER ASSEMBLY, and the Item Number from the table below.

Part #	Description	QTY
1c	Bolt m6 x 12	6
2c	Air Duct	1
3c	Intake Valve Guide	1
4c	Lead Wind Cover	1
5c	Stud m6 x 109	2
6c	Set Pin m10 x 16	2
7c	Cylinder Head Gasket	1
8c	Cylinder Head Assembly	1

Part #	Description	QTY
9c	Stud m8 x 34	2
10c	Spark Plug F6TC	1
11c	Exhaust Valve Guide	1
12c	Circlip	1
13c	Bolt	4
14c	Gasket	1
15c	Cylinder Head Cover Assembly	1

## CRANKSHAFT, PISTON AND CONNECTING ROD ASSEMBLY DIAGRAM

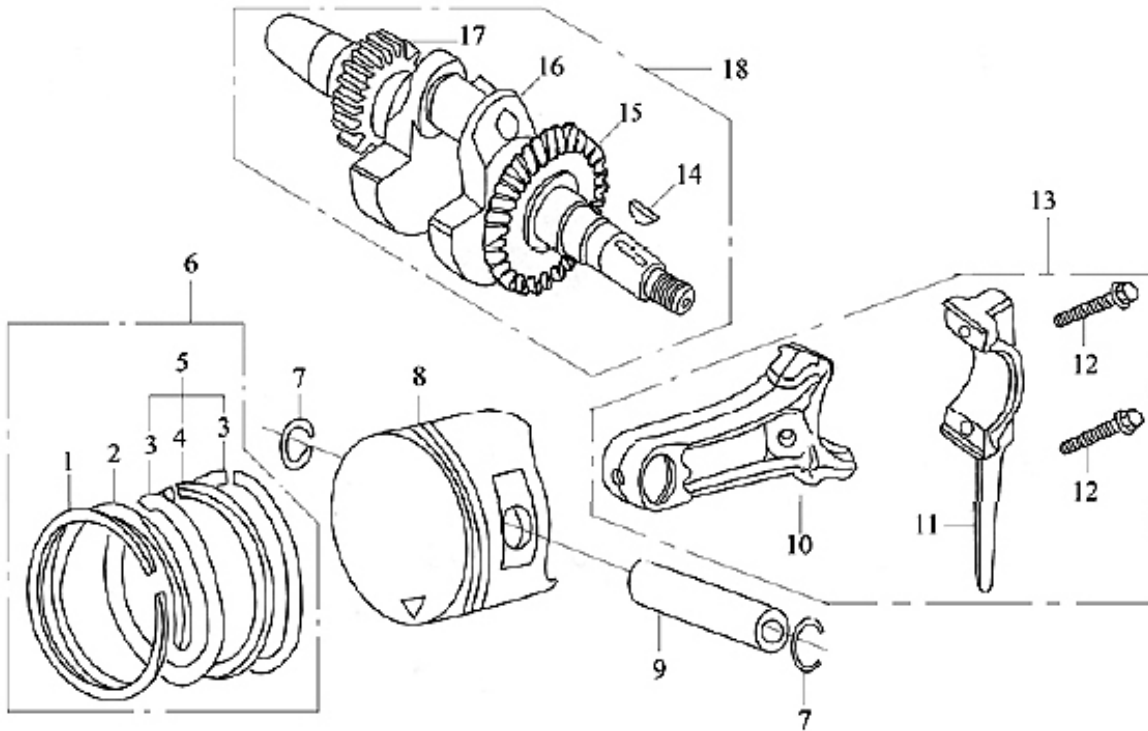

Note: When ordering parts from this list, specify: Parts List D, CRANKSHAFT, PISTON AND CONNECTING ROD ASSEMBLY, and the Item Number from the table below.

Part #	Description	QTY
1d	Piston Ring (I)	1
2d	Piston Ring (II)	1
3d	Side Rail	2
4d	Expander	1
5d	Scraper Ring Set	1
6d	Piston Ring Assembly	1
7d	Piston Pin Circlip	2
8d	Piston	1
9d	Piston Pin	1

Part #	Description	QTY
10d	Connecting Rod	1
11d	Connecting Rod Cover	1
12d	Bolt	2
13d	Connecting Rod Assembly	1
14d	Woodruff Key	1
15d	Drive Gear	1
16d	Crankshaft	1
17d	Timing Drive Gear	1
18d	Crankshaft Assembly	1



## CAMSHAFT AND ROCKER VALVE ASSEMBLY DIAGRAM

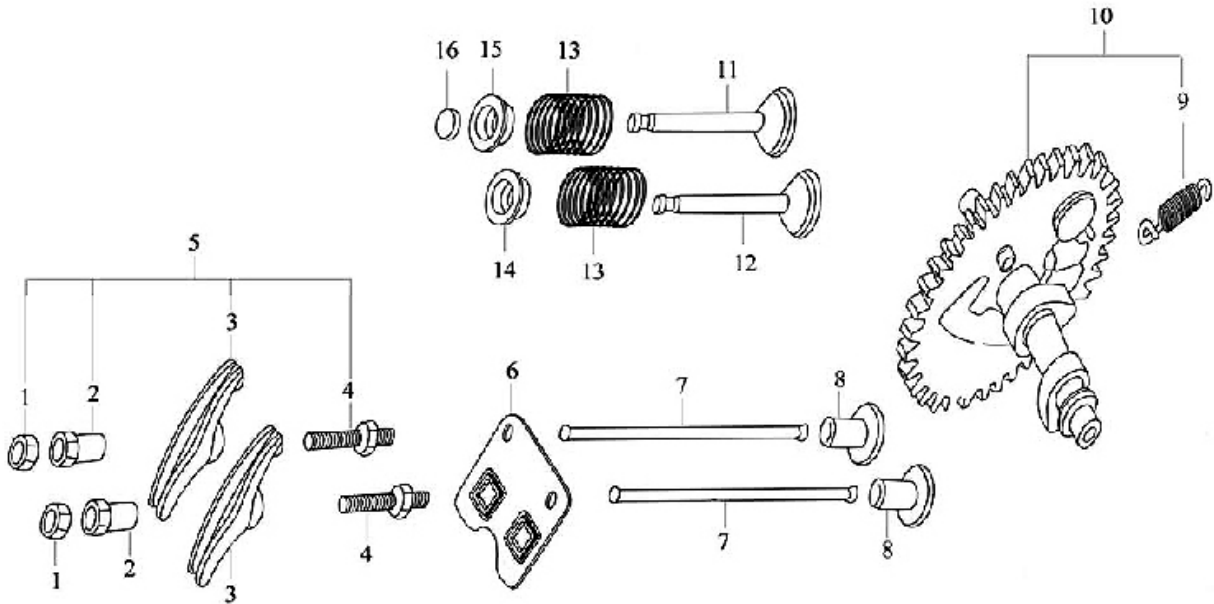

Note: When ordering parts from this list, specify: Parts List E, CAMSHAFT AND ROCKER VALVE ASSEMBLY, and the Item Number from the table below.

Part #	Description	QTY
1e	Lock Nut	2
2e	Sleeve	2
3e	Rocker Arm	2
4e	Valve Gap Adjusting Bolt	2
5e	Rocker Valve Assembly	2
6e	Pusher Guide	1
7e	Push Rod	2
8e	Tappet	2
9e	Governor Spring	1

Part #	Description	QTY
10e	Camshaft Assembly	1
11e	Exhaust Valve	1
12e	Intake Valve	1
13e	Valve Spring	2
14e	Intake Valve Spring Seat Retainers	2
15e	Exhaust Valve Spring Seat Retainers	2
16e	Cap	1

## CARBURETOR ASSEMBLY DIAGRAM

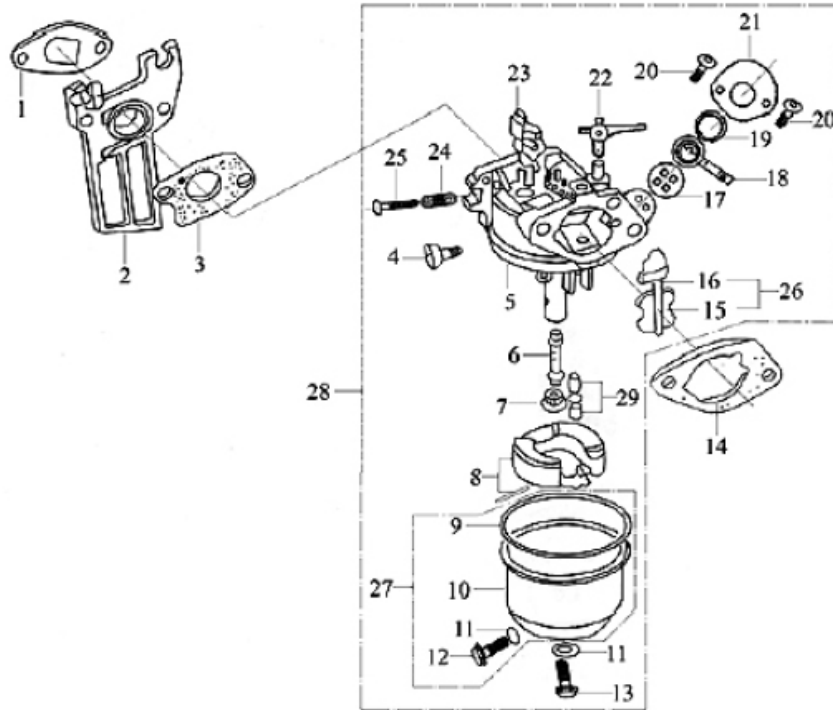

Note: When ordering parts from this list, specify: Parts List F, CARBURETOR ASSEMBLY, and the Item Number from the table below.

Part #	Description	QTY
1f	Inlet Gasket	1
2f	Connecting Block	1
3f	Carburetor Gasket	1
4f	Idle Adjustment Screw	1
5f	Mixture Chamber Bode	1
6f	Main Nozzle	1
7f	Main Jet	1
8f	Float	1
9f	Float Chamber Gasket	1
10f	Float Chamber	1
11f	Washer	2
12f	Float Chamber Drain Screw	1
13f	Screw	1
14f	Air Cleaner Gasket	1
15f	Choke	1

Part #	Description	QTY
16f	Choke Stem	1
17f	Air Seal Washer	1
18f	Throttle Lever	1
19f	Washer	1
20f	Screw m4	2
21f	Cover	1
22f	Choke Switch	1
23f	Throttle Unit	1
24f	Mixture Adjustment Screw Spring	1
25f	Mixture Adjustment Screw	1
26f	Choke Unit	1
27f	Float Chamber	1
28f	Carburetor Assembly	1
29f	Float Needle	1

## FUEL TANK ASSEMBLY DIAGRAM

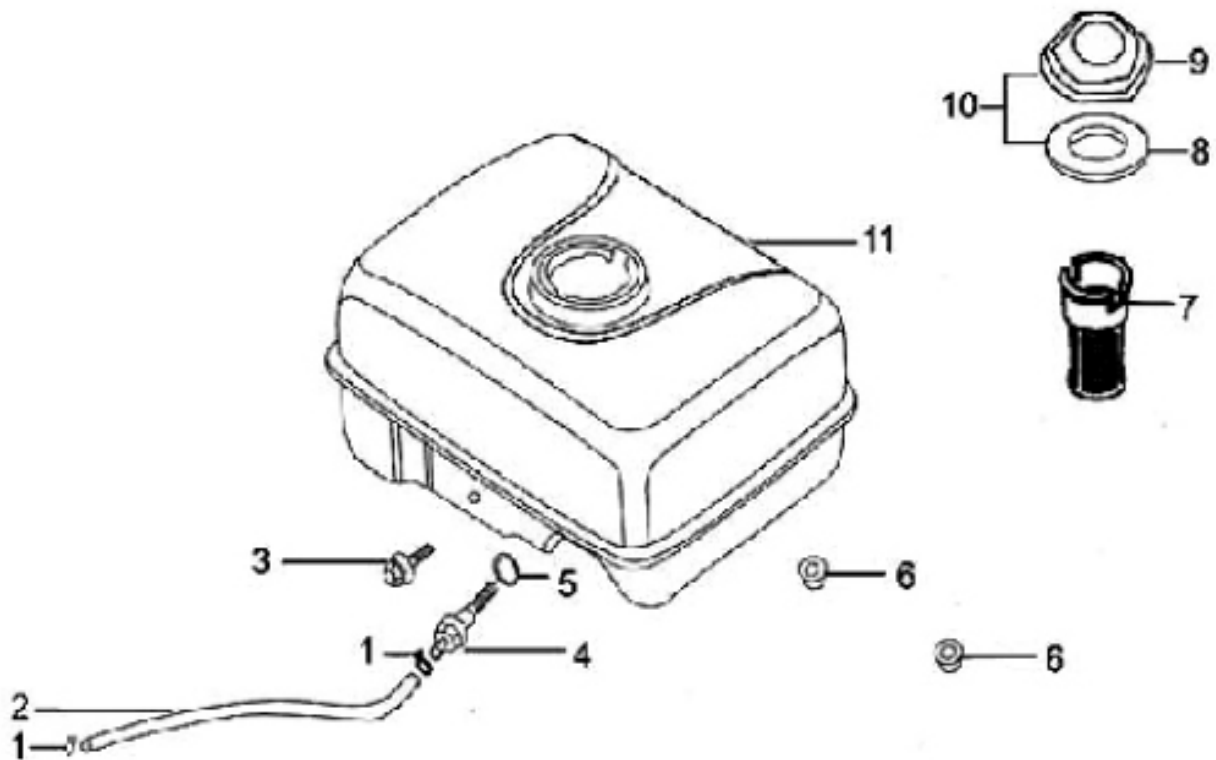

Note: When ordering parts from this list, specify: Parts List G, FUEL TANK ASSEMBLY, and the Item Number from the table below.

Part #	Description	QTY
1g	Pipe Clamp	2
2g	Pipe Outlet	1
3g	Bolt m6 x 22	1
4g	Connector	1
5g	Packing Ring	1
6g	Nut m6	2

Part #	Description	QTY
7g	Filter Cup	1
8g	Packing Ring	1
9g	Fuel Filler Cap	1
10g	Fuel Filler Cap with Packing Ring	1
11g	Fuel Tank	1

## AIR CLEANER ASSEMBLY DIAGRAM

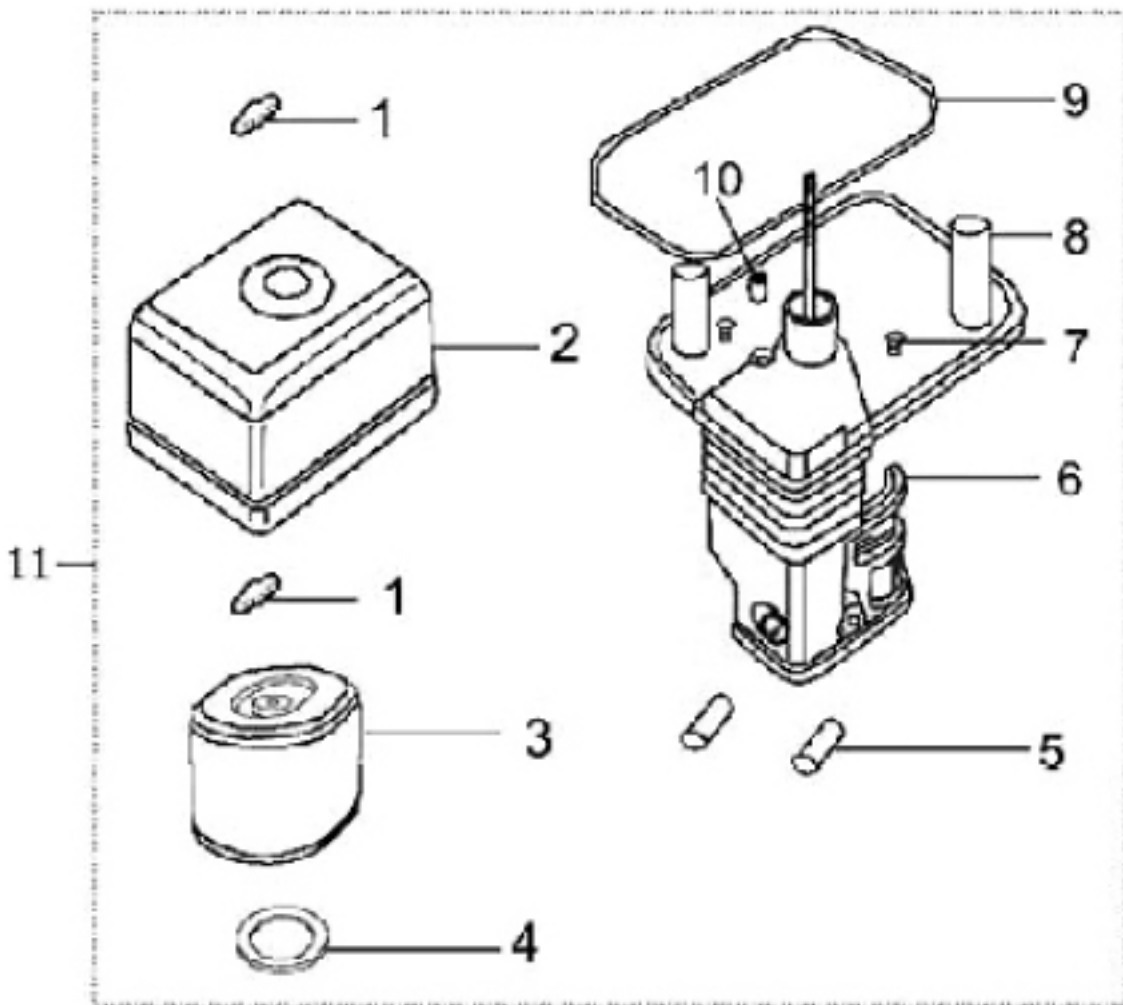

Note: When ordering parts from this list, specify: Parts List H, AIR CLEANER ASSEMBLY, and the Item Number from the table below.

Part #	Description	QTY
1h	Wing Nut	2
2h	Air Cleaner Cover	1
3h	Filter Element	1
4h	Washer	1
5h	Sleeve A	2
6h	Air Cleaner Housing	1

Part #	Description	QTY
7h	Screw m5 x 12	2
8h	Air Cleaner Base	1
9h	Gasket	1
10h	Sleeve B	1
11h	Air Cleaner Assembly	1

## MUFFLER ASSEMBLY DIAGRAM

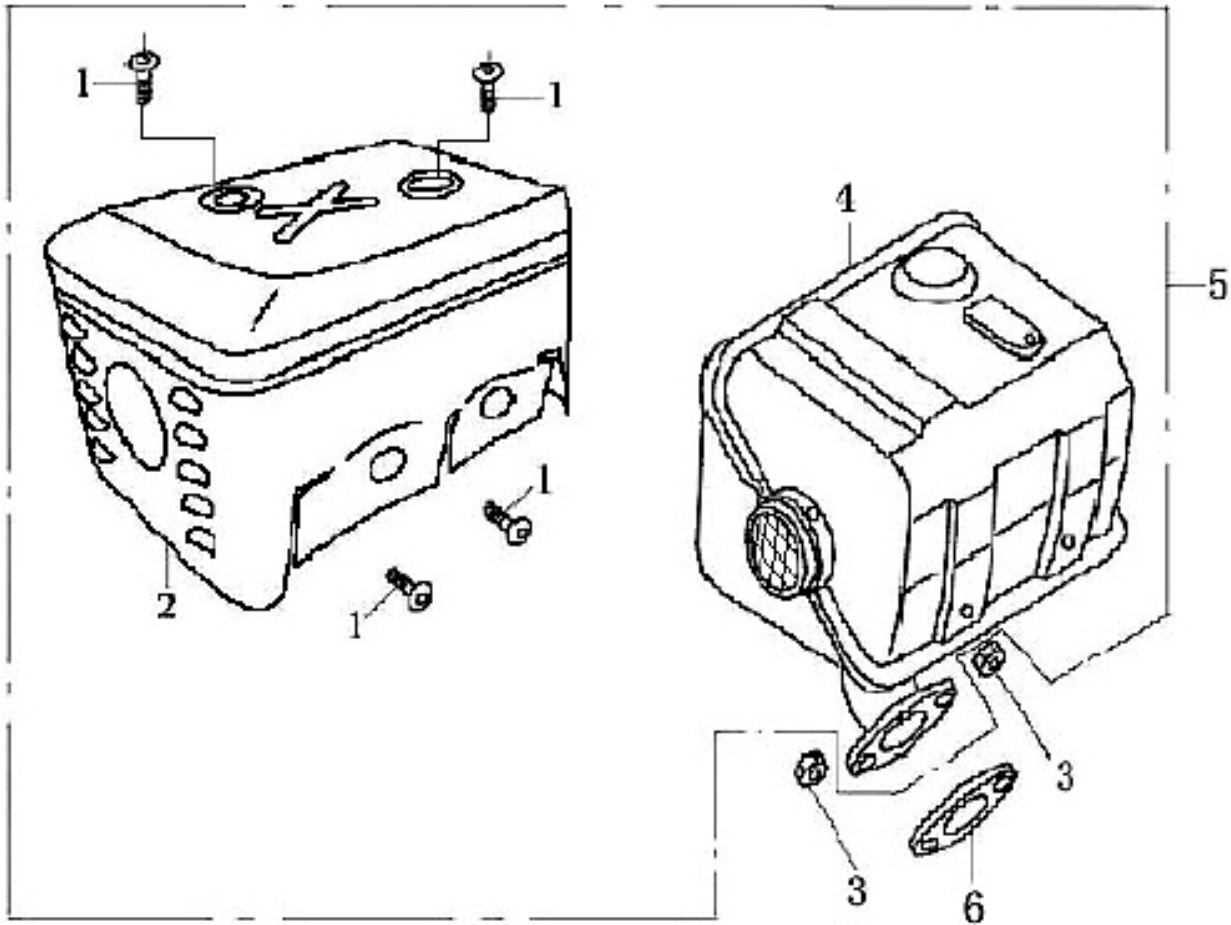

Note: When ordering parts from this list, specify: Parts List J, MUFFLER ASSEMBLY, and the Item Number from the table below.

Part #	Description	QTY
1j	J-Screw m5 x 8	4
2j	Muffler Hood	1
3j	Nut m8	2
4j	Muffler	1
5j	Exhaust Muffler	1
6j	Exhaust Gasket	1

## RECOIL STARTER ASSEMBLY DIAGRAM

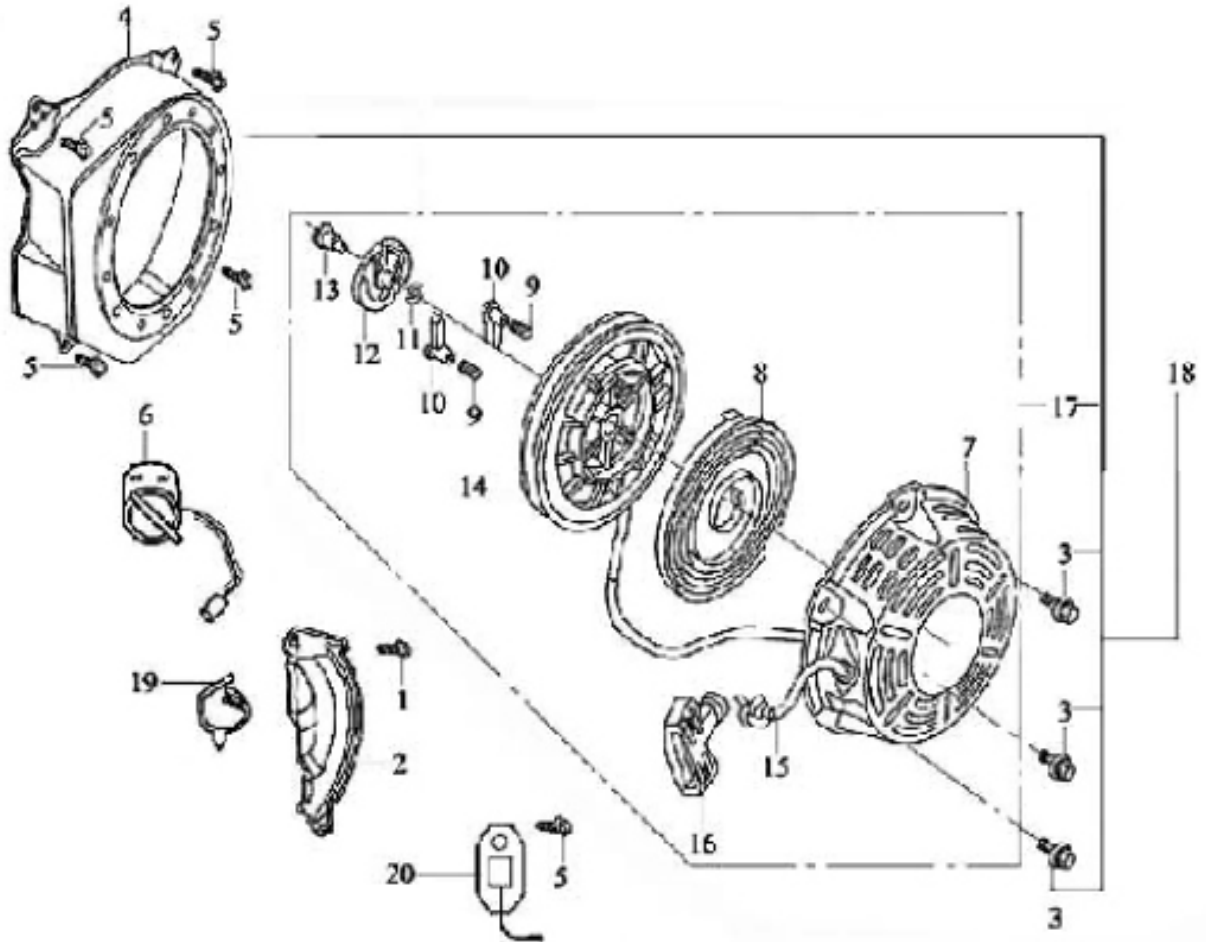

Note: When ordering parts from this list, specify: Parts List K, RECOIL STARTER ASSEMBLY, and the Item Number from the table below.

Part #	Description	QTY
1k	Bolt m6 x 22	1
2k	Crankcase Side Plate Assembly	1
3k	Bolt m6 x 18	3
4k	Fan Hood Assembly	1
5k	Bolt m6 x 12	5
6k	Engine Switch	1
7k	Casing	1
8k	Spiral Spring	1
9k	Ratchet Spring	2
10k	Ratchet	2

Part #	Description	QTY
11k	Friction Spring	1
12k	Spring Lid	1
13k	Set Screw	1
14k	Starter Wheel	1
15k	Starter Rope	1
16k	Pull Cord Handle	1
17k	Recoil Starter	1
18k	Recoil Starter Assembly	1
19k	Plastic Clip	1
20k	Diode	1

## REGULATOR CONTROL ASSEMBLY DIAGRAM

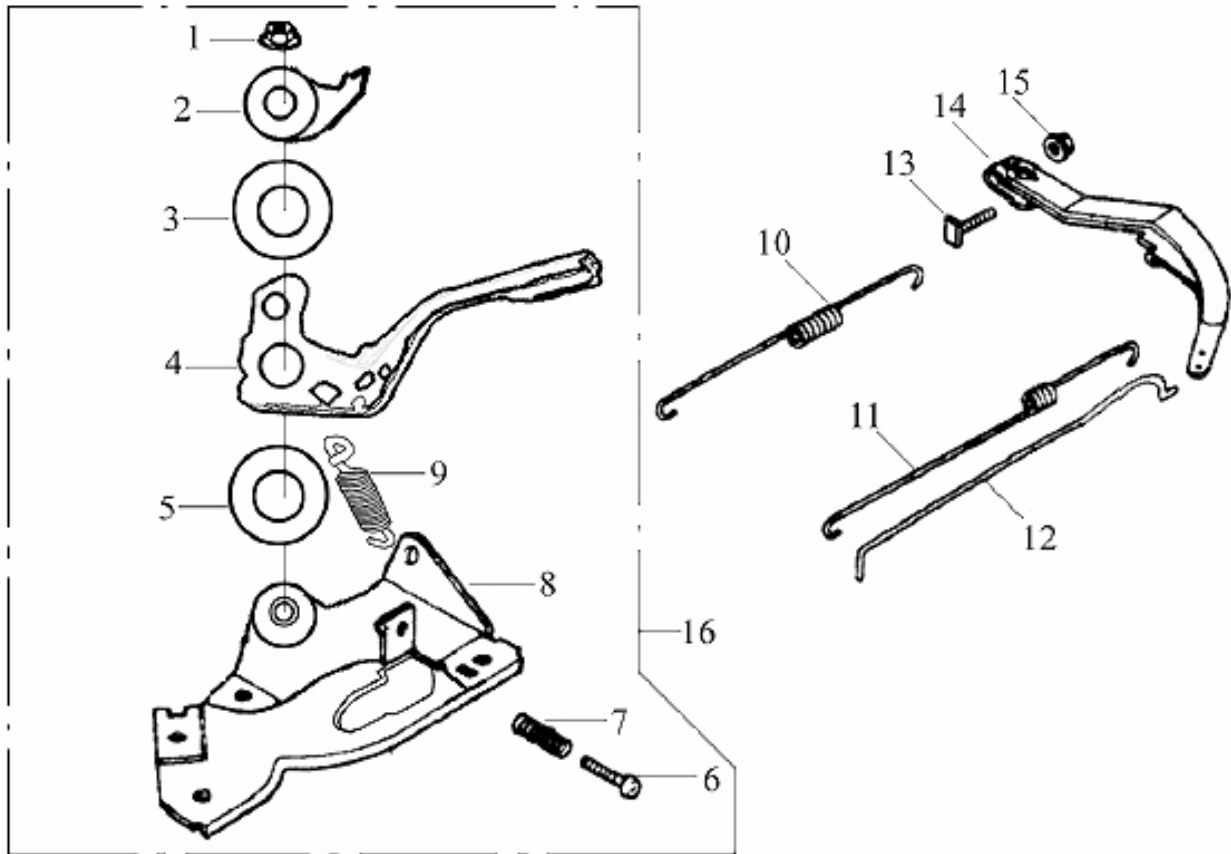

Note: When ordering parts from this list, specify: Parts List L, REGULATOR CONTROL ASSEMBLY, and the Item Number from the table below.

Part #	Description	QTY
1l	Nut m6	1
2l	Setting Panel	1
3l	Patch Spring	1
4l	Hand Grip	1
5l	Washer	1
6l	Bolt m5 x 25	1
7l	Regulating Spring	1
8l	Support Panel Assembly	1

Part #	Description	QTY
9l	Spring	1
10l	Back Spring	1
11l	Fine Regulating Spring	1
12l	Pull Rod	1
13l	Lock Bolt	1
14l	Regulating Arm	1
15l	Nut m6	1
16l	Regulating Frame Assembly	1

---

## FLYWHEEL ASSEMBLY DIAGRAM

---

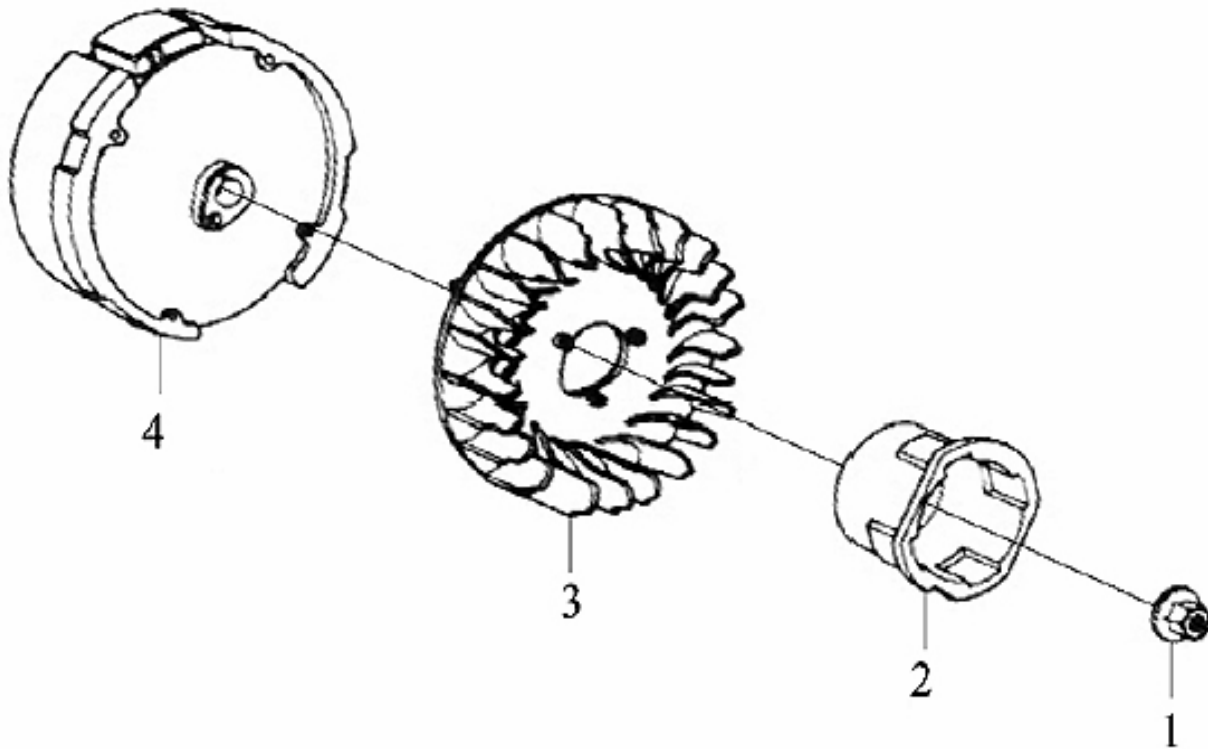

Note: When ordering parts from this list, specify: Parts List M, FLYWHEEL ASSEMBLY, and the Item Number from the table below.

Part #	Description	QTY
1m	Nut m14 x 1.5	1
2m	Starting Flange	1
3m	Flywheel Fan	1
4m	Flywheel	1



## IGNITION COIL ASSEMBLY DIAGRAM

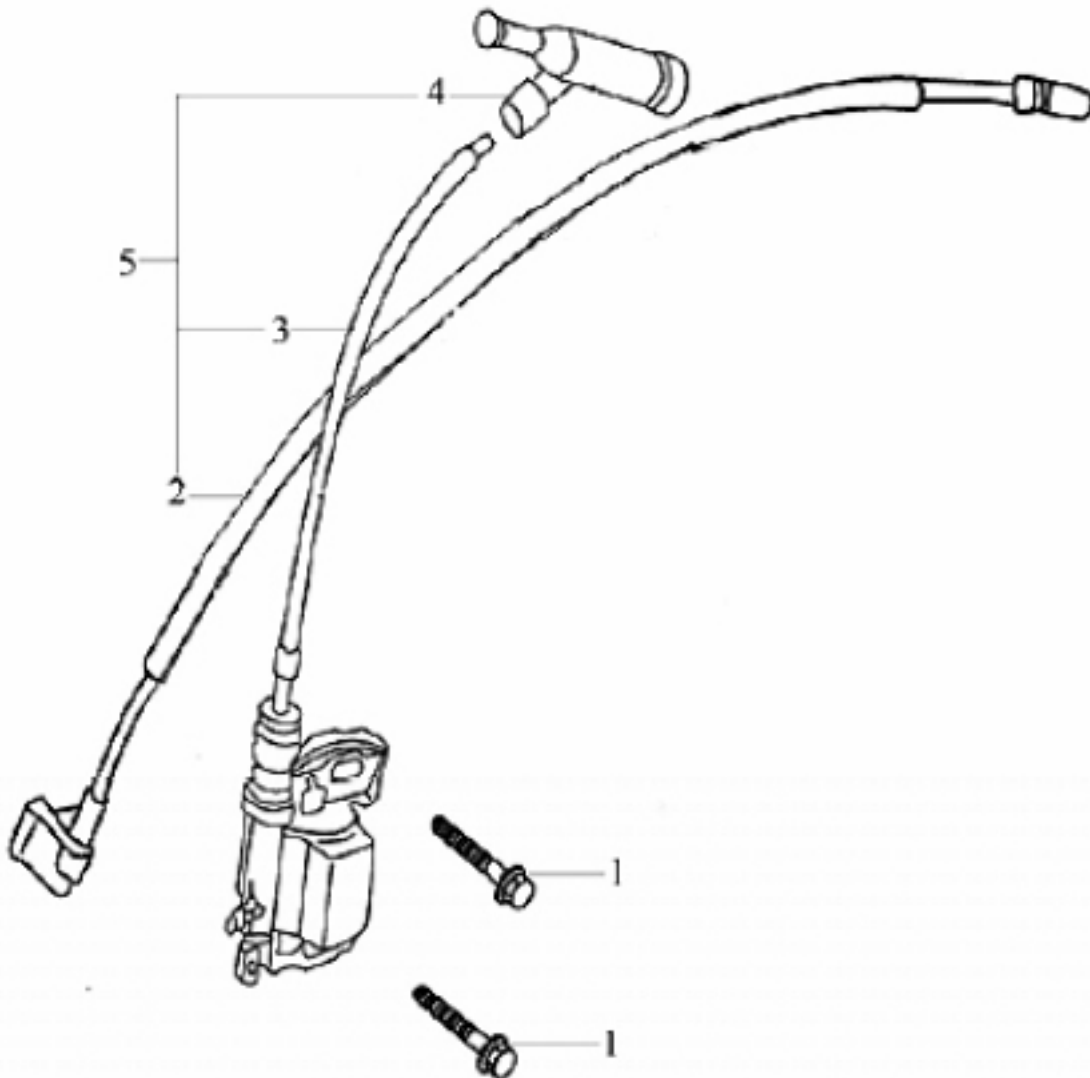

Note: When ordering parts from this list, specify: Parts List N, IGNITION COIL ASSEMBLY, and the Item Number from the table below.

Part #	Description	QTY
1n	Screw m6 x 22	2
2n	Engine Stop Cable	1
3n	Ignition Coil	1
4n	Spark Plug Cap	1
5n	Ignition Coil Assembly	1

# WIRING DIAGRAM

B1	Black
Y	Yellow
G	Green

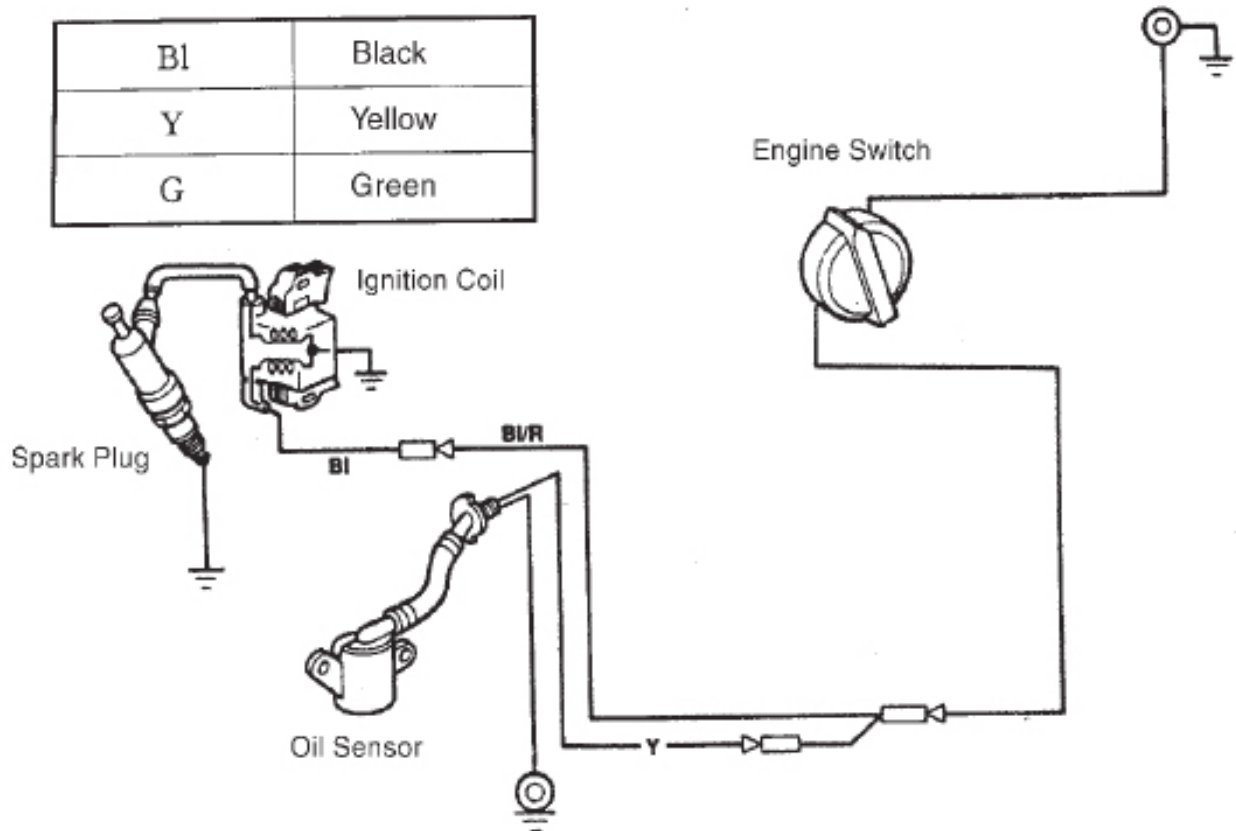

---

## LIMITED 1 YEAR / 90 DAY WARRANTY

---

Harbor Freight Tools Co. makes every effort to assure that its products meet high quality and durability standards, and warrants to the original purchaser that for a period of ninety days from date of purchase that the engine/motor, the belts (if so equipped), and the blades (if so equipped) are free of defects in materials and workmanship. Harbor Freight Tools also warrants to the original purchaser, for a period of one year from date of purchase, that all other parts and components of the product are free from defects in materials and workmanship (90 days if used by a professional contractor or if used as rental equipment). This warranty does not apply to damage due directly or indirectly, to misuse, abuse, negligence or accidents, repairs or alterations outside our facilities, normal wear and tear, or to lack of maintenance. We shall in no event be liable for death, injuries to persons or property, or for incidental, contingent, special or consequential damages arising from the use of our product. Some states do not allow the exclusion or limitation of incidental or consequential damages, so the above limitation of exclusion may not apply to you. THIS WARRANTY IS EXPRESSLY IN LIEU OF ALL OTHER WARRANTIES, EXPRESS OR IMPLIED, INCLUDING THE WARRANTIES OF MERCHANTABILITY AND FITNESS.

To take advantage of this warranty, the product or part must be returned to us with transportation charges prepaid. Proof of purchase date and an explanation of the complaint must accompany the merchandise. If our inspection verifies the defect, we will either repair or replace the product at our election or we may elect to refund

the purchase price if we cannot readily and quickly provide you with a replacement. We will return repaired products at our expense, but if we determine there is no defect, or that the defect resulted from causes not within the scope of our warranty, then you must bear the cost of returning the product.

This warranty gives you specific legal rights and you may also have other rights which vary from state to state.

**3491 Mission Oaks Blvd. • PO Box  
6009 • Camarillo, CA 93011 • (800)  
444-3353**

---

## EMISSION CONTROL SYSTEM WARRANTY

---

### United States Emission Control Defects Warranty Statement

The United States Environmental Protection Agency (herein EPA) and Harbor Freight Tools (herein HFT) are pleased to explain the emission control system warranty on your 1997 and later Small Off-Road Engine (herein engine). Within the United States, new off-road, spark-ignition engines certified for model year 1997 and later, must be designed, built and equipped to meet the stringent anti-smog standards set forth by the EPA. HFT must warrant the emission control system on your engine for the periods of time described below, provided there has been no abuse, neglect or improper maintenance of your engine.

Your emission control system may include parts such as the carburetor or fuel-injection system, and the ignition system. Also included may be hoses, belts, connectors and other emission-related assemblies.

Where a warrantable condition exists, HFT will repair your engine at no cost to you including diagnosis, parts and labor.

### Manufacturer's Warranty Coverage

The 1997 and later engines are warranted for two (2) years. If any emission-related part on your engine is defective, the part will be repaired or replaced by HFT.

---

### Harbor Freight Tools Emission Control Defects Warranty Coverage

Engines are warranted for a period of two (2) years relative to emission control parts defects, subject to the provisions set forth below. If any emission related part on your engine is defective, the part will be repaired or replaced by HFT.

#### **1. Owner's Warranty Responsibilities**

- As the engine owner, you are responsible for the performance of the required maintenance listed in your Owner's Manual. HFT recommends that you retain all receipts covering main-

SKU 65322 or 65323 For technical questions, please call 1-800-444-3353. Page 35

tenance on your engine, but HFT cannot deny warranty solely for the lack of receipts or for your failure to ensure the performance of all scheduled maintenance.

- As the engine owner, you should, however, be aware that HFT may deny you warranty coverage if your engine or a part has failed due to abuse, neglect, improper maintenance, or unapproved modifications.
- You are responsible for shipping your engine to a HFT warranty station as soon as a problem exists. Contact the HFT Customer Service department at the number below to make shipping arrangements. The warranty repairs should be completed in a reasonable amount of time, not to exceed 30 days.

If you have any questions regarding your warranty rights and responsibilities, you should contact the Harbor Freight Tools Customer Service Department at 1-800-444-3353.

## **Harbor Freight Tools Emission Control Defects Warranty Provisions**

### **1. 1. Length of Coverage**

HFT warrants to a first retail purchaser and each subsequent purchaser that the engine is free from defects in materials and workmanship that cause the failure of warranted parts for a period of two (2) years after the date of delivery to the first retail purchaser.

### **1. 2. No Charge Repair or Replacement**

Repair or replacement of any warranted part will be performed at no charge to the owner if the work is performed through a warranty station authorized by HFT. For emissions warranty service, contact the HFT Customer Service Department at 1-800-444-3353.

### **1. 3. Consequential Damages Coverage**

Coverage under this warranty shall also extend to the failure of any engine components caused by the failure of any warranted part while it is still covered under this warranty.

### **1. 4. Coverage Exclusions**

Warranty claims shall be filed in accordance with the provisions of the HFT warranty policy explained in the box at the top of the previous page. HFT shall not be liable for any loss of use of the engine, for any alternative usage, for any damage to goods, loss of time, or inconvenience. Warranty coverage shall also be excluded for any part which fails, malfunctions, or is damaged due to failure to follow the maintenance and operating instructions set forth in the Owner's Manual including, but not limited to:

- a) Use of parts which are not authorized by HFT

- b) Improper installation, adjustment or repair of the engine or of any warranted part unless performed by an authorized warranty center
- c) Failure to follow recommendations on fuel use contained in the Owner's Manual
- d) Improper or inadequate maintenance of any warranted parts
- e) Repairs performed outside of the authorized warranty service dealers
- f) Alterations by changing, adding to or removing parts from the engine.

### **1. 5. Service and Maintenance**

Component parts which are not scheduled for replacement as required maintenance or are scheduled only for regular inspection to the effect of "repair or replace as necessary" are warranted for the warranty period. Any warranted part which is scheduled for replacement as required maintenance is warranted for the period of time up to the first scheduled replacement point for that part. Any replacement part, provided it is equivalent in durability and performance, may be used in performance of maintenance or repairs. The owner is responsible for commissioning a qualified technician/mechanic to perform all required maintenance, as outlined in the Inspection, Cleaning, and Maintenance section in this manual.

### **1. 6. Warranted Parts**

#### **1) Fuel Metering System**

- i) Carburetor and its internal parts.
- ii) Fuel pump (if so equipped).
- iii) Cold start enrichment system.

#### **2) Air Induction System**

- i) Intake pipe/manifold.
- ii) Air cleaner.

#### **3) Ignition System**

- i) Spark plug.
- ii) Magneto ignition system.

#### **4) Catalyst System (if so equipped)**

- i) Exhaust pipe stud.
- ii) Muffler.
- iii) Catalytic converter (if so equipped).

#### **5) Miscellaneous Items Used in Above Systems**

- i) Vacuum, temperature and time sensitive valves and switches.
- ii) Hoses, belts, connectors, and assemblies.

**Record Product's Serial Number Here:** \_\_\_\_\_

**Note:** If product has no serial number, record month and year of purchase instead.

**Note:** Some parts are listed and shown for illustration purposes only, and are not available individually as replacement parts.

## Free Manuals Download Website

<http://myh66.com>

<http://usermanuals.us>

<http://www.somanuals.com>

<http://www.4manuals.cc>

<http://www.manual-lib.com>

<http://www.404manual.com>

<http://www.luxmanual.com>

<http://aubethermostatmanual.com>

Golf course search by state

<http://golfingnear.com>

Email search by domain

<http://emailbydomain.com>

Auto manuals search

<http://auto.somanuals.com>

TV manuals search

<http://tv.somanuals.com>