

The Harman PF 100 Pellet Pro Furnace

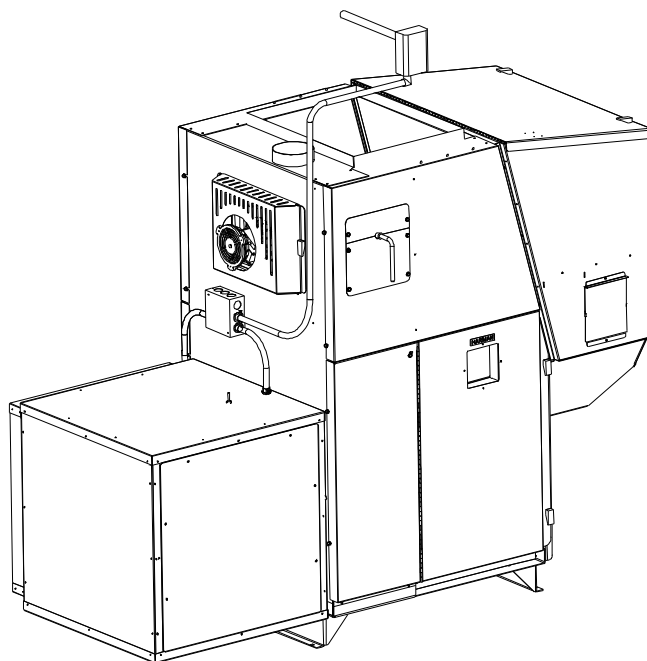

"Ce manuel est disponible en Français sur demande"

R7

SAFETY NOTICE

PLEASE READ THIS ENTIRE MANUAL BEFORE YOU INSTALL AND USE YOUR NEW ROOM HEATER. FAILURE TO FOLLOW INSTRUCTIONS MAY RESULT IN PROPERTY DAMAGE, BODILY INJURY, OR EVEN DEATH.

FOR USE IN THE U.S. AND CANADA. SUITABLE FOR INSTALLATION IN MOBILE HOMES

IF THIS HARMAN PELLET FURNACE IS NOT PROPERLY INSTALLED, A HOUSE FIRE MAY RESULT. FOR YOUR SAFETY, FOLLOW INSTALLATION DIRECTIONS.

CONTACT LOCAL BUILDING OR FIRE OFFICIALS ABOUT RESTRICTIONS AND INSTALLATION INSPECTION REQUIREMENTS IN YOUR AREA.

CONTACT YOUR LOCAL AUTHORITY (SUCH AS MUNICIPAL BUILDING DEPARTMENT, FIRE DEPARTMENT, FIRE PREVENTION BUREAU, ETC.) TO DETERMINE THE NEED FOR A PERMIT.

CETTE GUIDE D'UTILISATION EST DISPONIBLE EN FRANCAIS. CHEZ VOTRE CONCESSIONNAIRE DE HARMAN STOVE COMPANY.

SAVE THESE INSTRUCTIONS.

PF100 Parts

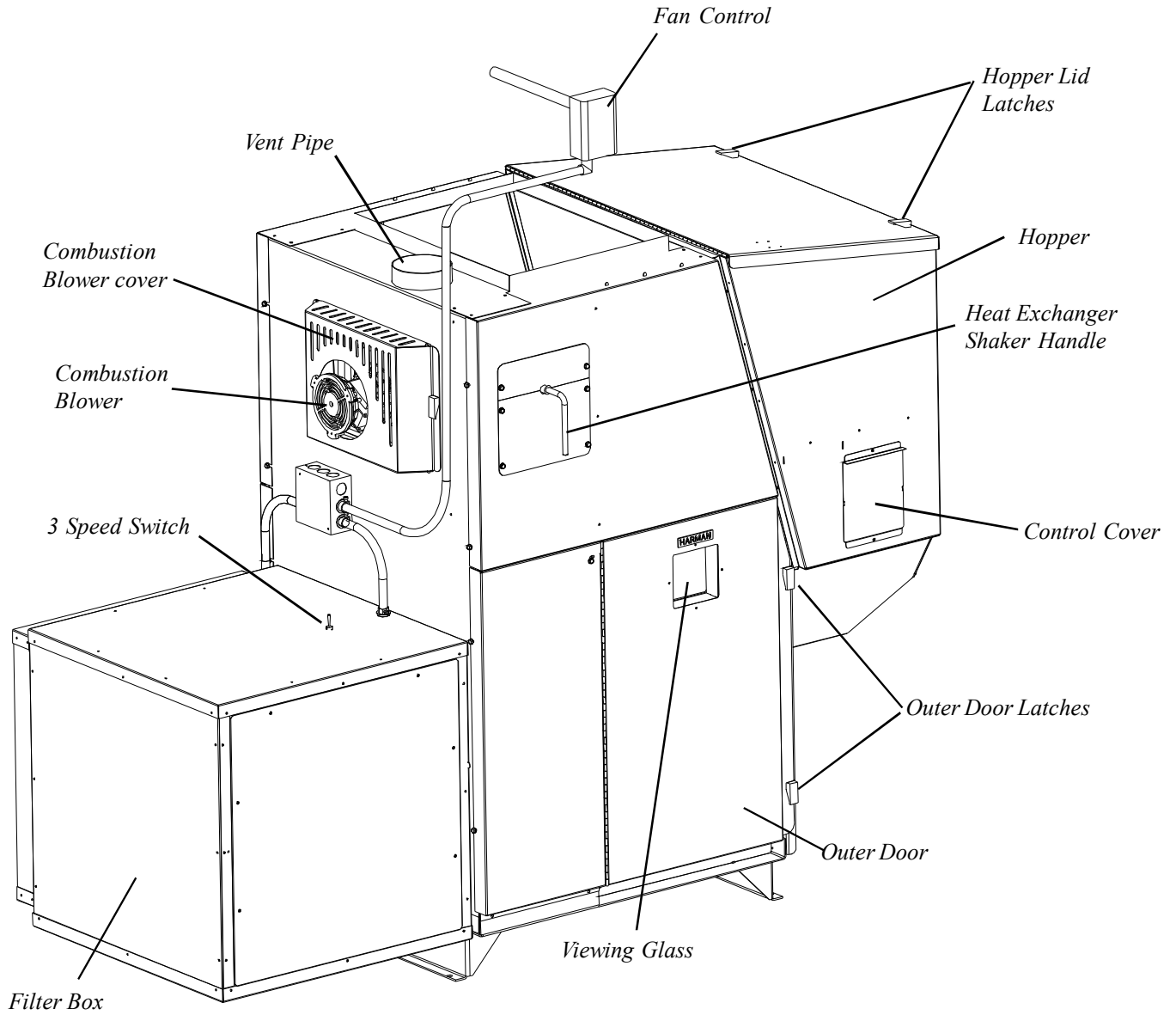

Table of Contents

Assembly	4
Venting	10
Installation	15
Operation	21
Maintenance	29
Troubleshooting	34
Feeder Parts	35
Specifications	36
Wiring Diagram	37
Parts List & Options	38
Warranty	39
Testing Label	40
Quick Reference Start-Up	41

Please read this entire manual before you install and use your new furnace. Failure to follow instructions may result in property damage, bodily injury, or even death.

DO NOT INSTALL IN A MOBILE HOME.

SAVE THESE INSTRUCTIONS

Harman Stove Company

352 Mountain House Road
Halifax, PA 17032

PF100 3

Assembly

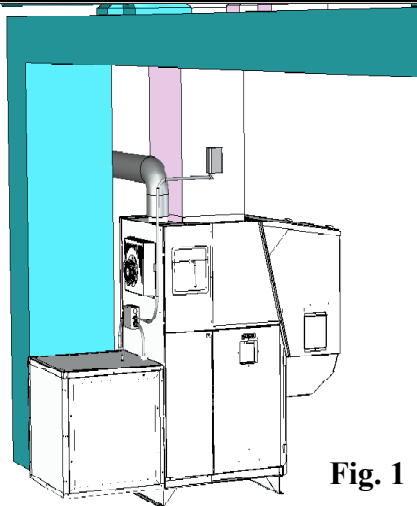

Fig. 1

Design

The first thing that needs to be done is deciding where and how the furnace will be installed.

Things that need to be taken into consideration are VENTING, SUPPLY & RETURN DUCTING, ELECTRICAL, and Condensation drainage (if A/C is installed). Don't forget access to the furnace for service.

When the return air inlet position is known the filter box and distribution blower can be installed. See pages 5, 6, 7, 8.

When the furnace is set into place venting can be done.

Venting

Use 4" pellet vent pipe to vent your PF 100.

A combustion blower is used to extract the combustion gases from the firebox. This creates a negative pressure in the firebox and a positive pressure in the venting system as shown in fig. 2. The longer the vent pipe and more elbows used in the system, the greater the flow resistance. Because of these facts we recommend using as few elbows as possible and 30 feet or less of vent pipe. The maximum horizontal run should not exceed 18 feet.

Be sure to use wall and ceiling pass through fittings (which are approved for pellet vent pipe) when going through combustible materials. Be sure to use a starting collar to attach the venting system to the stove. **The starting collar must be sealed to the stove flue collar with high temp silicone caulking or aluminum tape, and screwed into the stove flue collar at least three (3) places.**

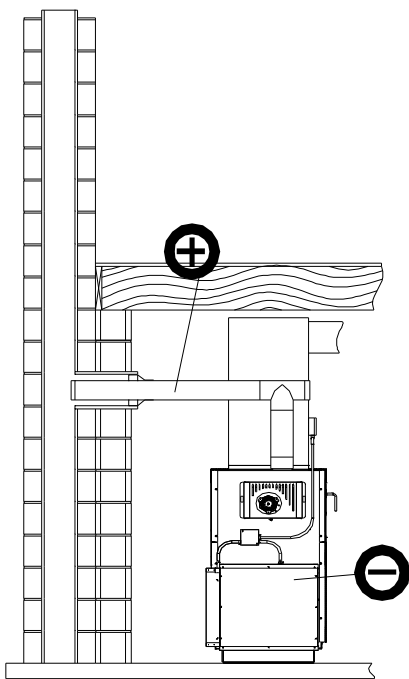

Fig. 2

Vent Pipe

4" pellet venting pipe (also known as PL vent) is constructed of two layers with air space between the layers. This air space acts as an insulator and reduces the outside surface temperature to allow a clearance to combustibles of only 2 inches. This 2 inch clearance is also approved by the pipe manufacturers. See images on left. See page 14 (Fig. 24 and 26) for larger images.

The sections of pipe lock together to form an air tight seal in most cases; however, in some cases a perfect seal is not achieved. For this reason and the fact that the PF100 operates with a positive vent pressure, **we specify that all joints within the structure should also be sealed with clear silicone.**

NOTE: Use only 4" diameter type "L" or "PL" venting system. Be sure to inspect and clean exhaust venting system frequently.

Clearances and Venting

The shaded areas are the clearances for the PL vent pipe that must be maintained at 3". After the venting leaves the shaded area it may be installed at 2" to combustibles. (Only UL listed wall pass-throughs and fire stops must be used.)

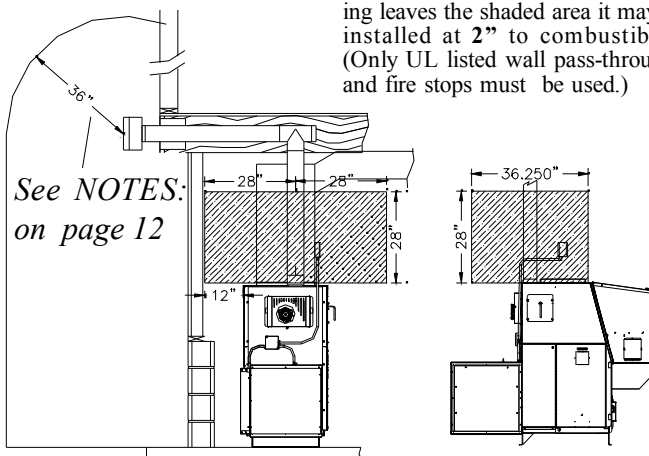

Filter Box (Cold Air Return)

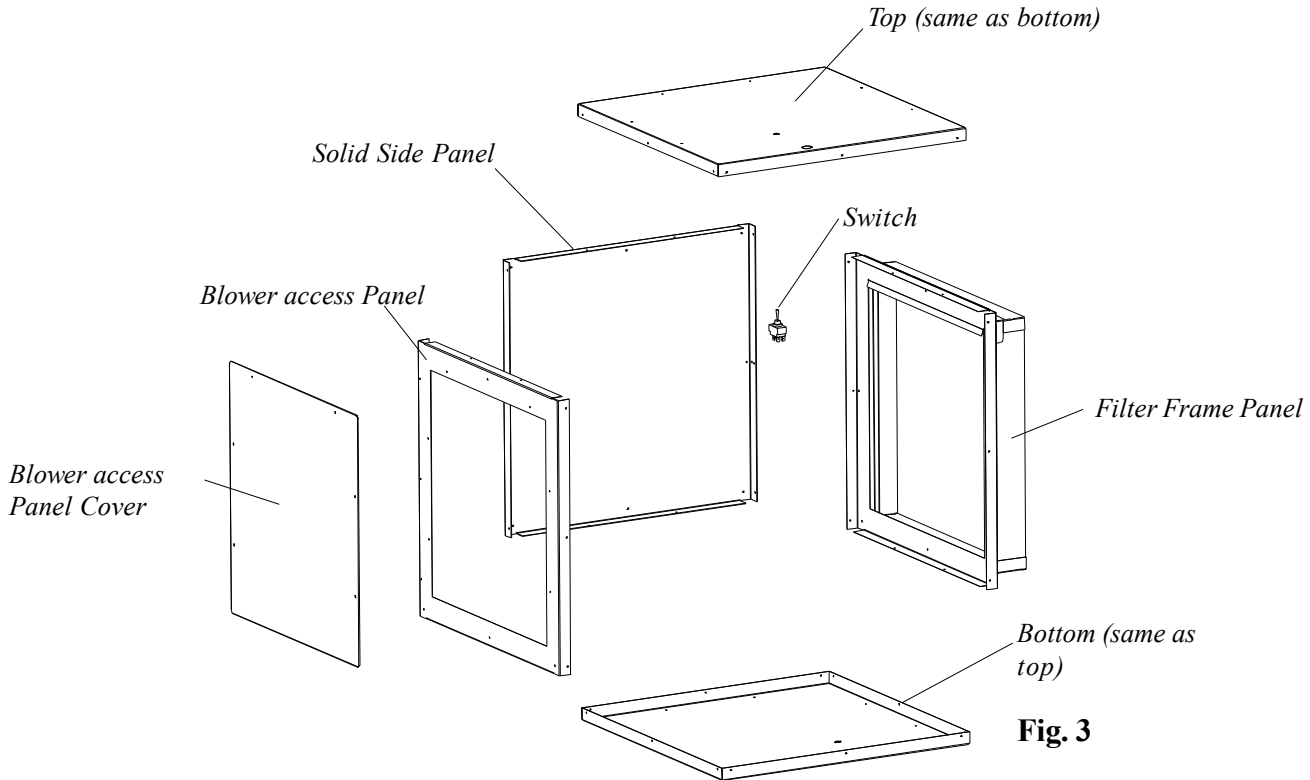

Fig. 3

NOTE: Read and follow all of the vent pipe manufacturers' instructions on the proper installation and support of the vent pipe. Adhere to all clearances.

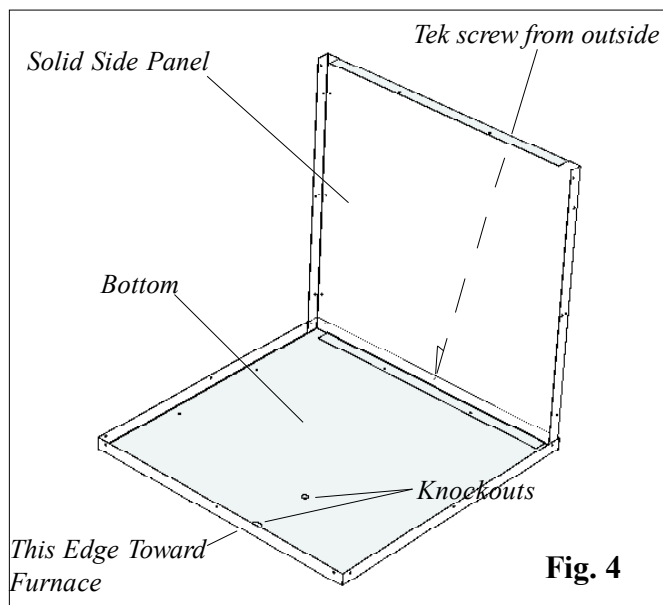

Fig. 4

Assembling Filter Box

The cold air return filter box can be assembled with the filter frame on either side or the back, provided there is access to the combustion blower and flue area.

It is not recommended that the filter frame be installed on the same side as the ash door due to the need to access the combustion blower, filter, and flue pipe for service.

1. Place the bottom on the floor. The edge closest to the knockouts will be the edge towards the furnace. See Fig. 4.

2. Place the desired vertical panel inside the bottom tray and hold into place with one Tek screw in the bottom middle hole. (solid panel shown) See Fig 4.

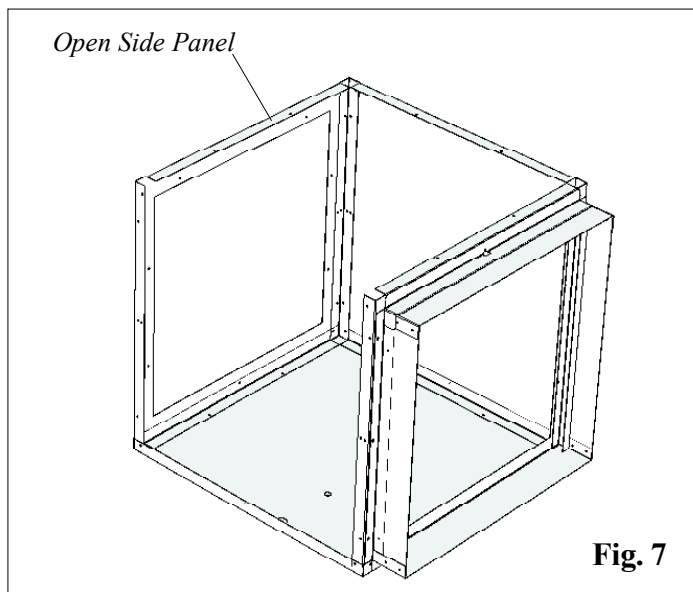
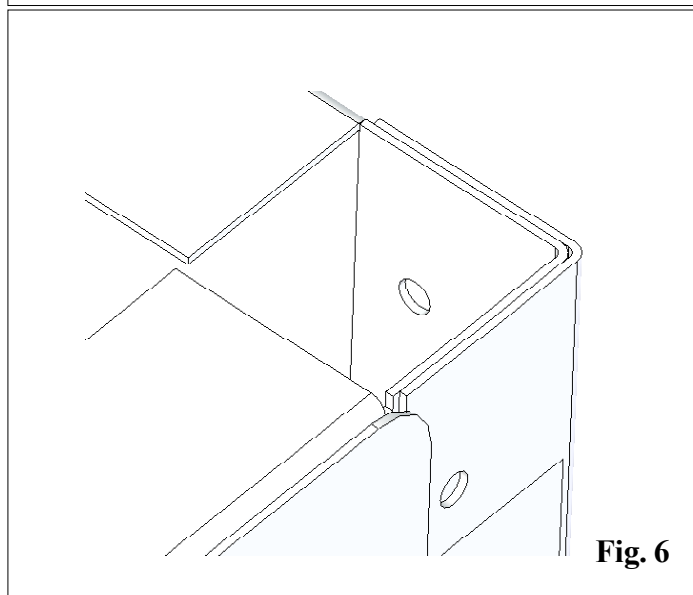
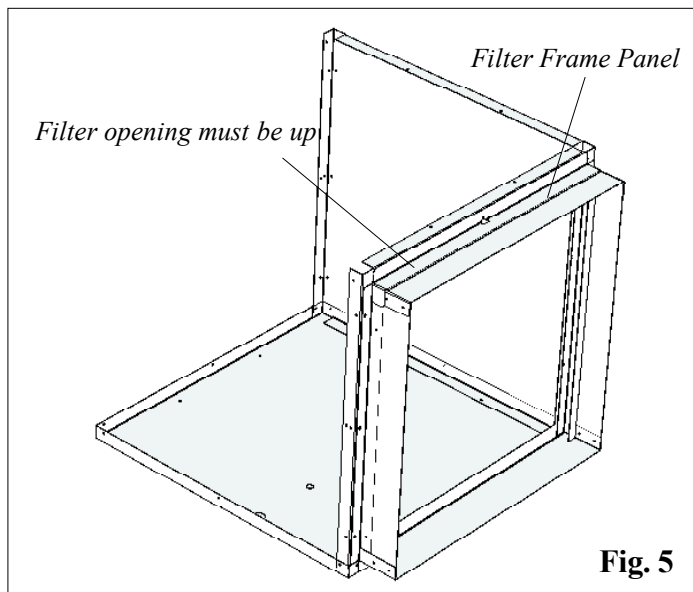

Assembling Filter Box, Cont'd

3. Place the filter frame panel inside the bottom and inside the solid panel corner. See Fig. 6 for corner detail. Make sure that the filter opening is up. See Fig. 5. Hold the filter panel to the solid panel with a Tek screw in the middle hole of the solid panel, and one in the bottom middle hole under the filter opening.

NOTE: Do not put any screws into any of the top holes at this time.

4. Place the remaining panel, (in this case the blower access panel) in the bottom panel and into the corner of the solid panel. See Fig. 7. Make sure that the panel is in the upright position. There are no cover mounting holes in the bottom edge of this panel. Hold the panel into place with one Tek screw in the middle hole of the solid panel and one in the bottom middle hole of the blower access panel.

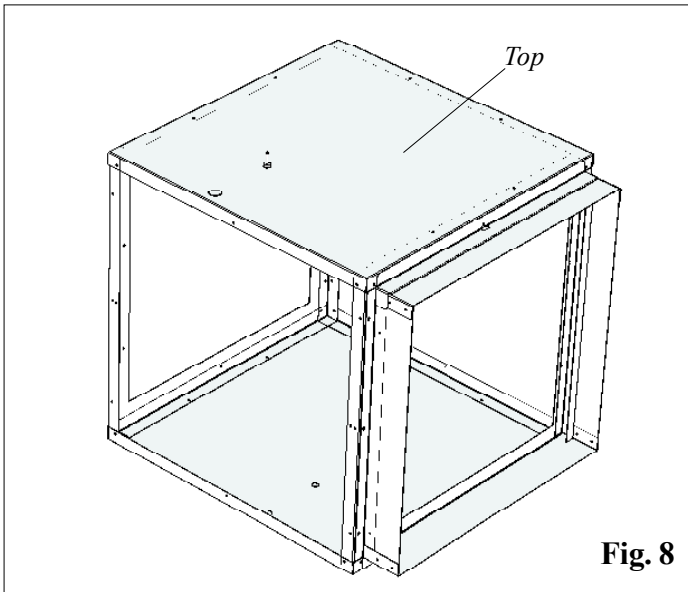

Fig. 8

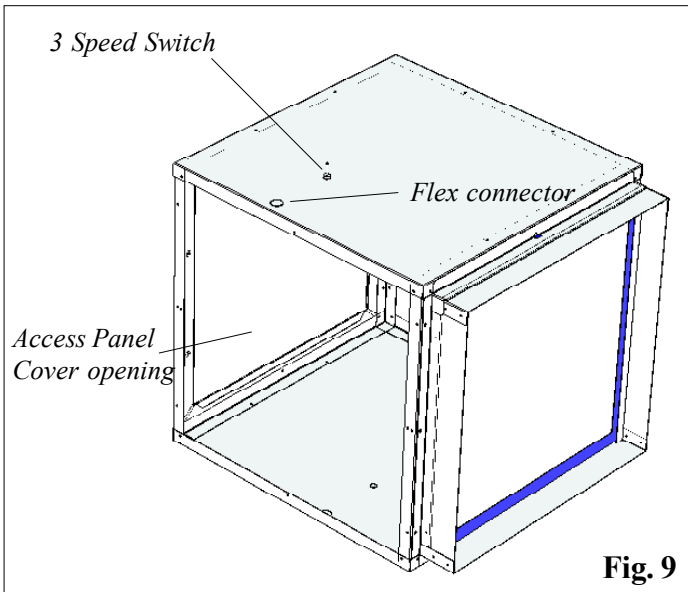

Fig. 9

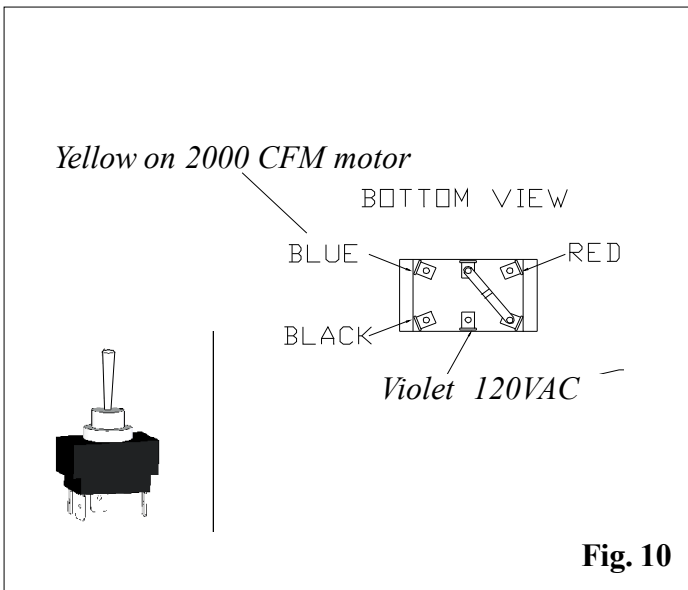

Fig. 10

Assembling Filter Box, Cont'd

5. Place the top on the filter box as shown in figure 8. At this time all Tek screws can be inserted around the filter box.

Note: Except for the (6) screws that attach the blower access panel in place. There should not be any screws protruding from the box on the side toward the furnace. Also **DO NOT** put a screw into the top center of the filter panel as a screw in this location will interfere with the filter access cover.

6. Pry out the two knockouts in the top of the box and install the flex connector and the switch. See Fig. 9.

Note: Don't forget the HI-MED-LO switch label on the switch before the locknut. Make sure that the set-screw on the flex connector is not pointing toward the furnace end of the box when the locknut is fully tightened. The filter box is now ready to install onto the furnace.

Follow the Blower mounting instructions on page 8 before continuing to step #7.

Note: The blower should be mounted on the furnace before the filter box for ease of distribution blower installation.

Note: It is best to wait until the blower, filter box, and cold air return duct work is installed before installing the filter and side panel.

7. After the Filter Box is installed on the furnace the electrical wiring to the three speed switch needs to be completed. WHITE to WHITE, VIOLET to the center terminal of the switch, and the BLACK, RED, BLUE to the terminals shown.

Note: The optional 1500 CFM blower is a single speed blower, therefore the three speed switch will not be used. The optional 2000CFM blower is a 4 speed, only hook up the three colors shown and tape off the orange wire. See Fig. 10.

8. Install the access panel cover by hooking the lip at the bottom of the cover over the edge in the filter box. Use 6 Tek screws to secure the access panel.

9. To install the filter, insert the filter into the filter slot and slide completely into the frame. Take note to the air flow arrow on the filter when installing. Slide the filter access cover over the opening with the upright angle toward the filter box. If a Tek was put into the middle hole by mistake, remove the screw to allow the access cover to fit properly.

Blower Assembly

Install the blower mounting brackets on the blower as shown in Fig. 11.

1. Install (4) Tek screws on each side where shown in Fig. 11. Start with the two center screws.

NOTE: There are two small holes in the discharge end of the blower that match the two center holes on the small angle of the blower bracket. The two (2) outer holes are drilled by the Tek screws.

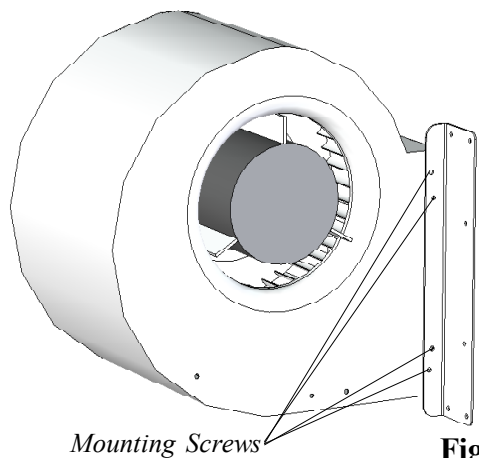

Fig. 11

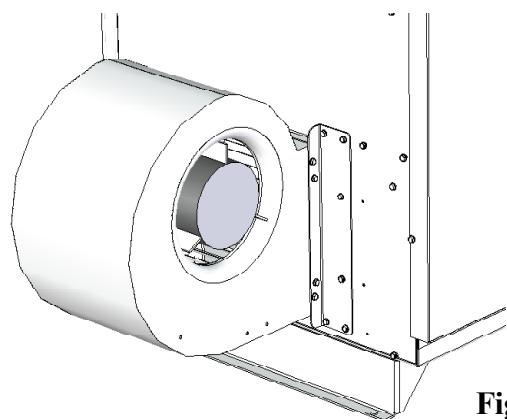

Fig. 12

2. Mount blower with brackets installed on the furnace as shown in Fig. 12. Each side will require 6 Tek screws.

NOTE: The furnace blower opening is made large enough for the use of a 1500 or 2000 CFM blower. The blower mounting brackets will fit either blower. The inner hole pattern is for the 1000 CFM blower and the outer pattern is for the 1500 or 2000 CFM blower.

NOTE: These Blower Motors are not designed to be operated without any positive static back pressure. OPERATION WITHOUT SUPPLY DUCTWORK OR IN FREE AIR WILL CAUSE MOTOR OVERLOAD AND PREMATURE FAILURE.

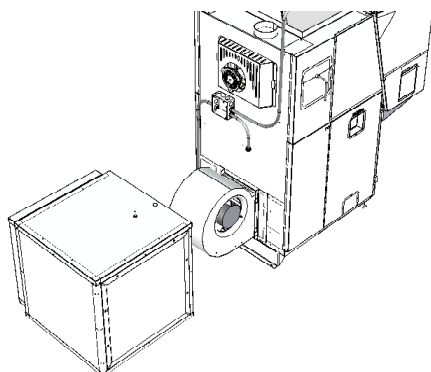

Fig. 13

CAUTION: Regardless of the supply air duct size installed, the Distribution Blower Motor **MUST** be checked for running Amperage. Check the motor name plate for the full load AMPS. If the amperage is running higher than that listed, a supply air restricting damper may be required to increase the supply plenum positive static pressure.

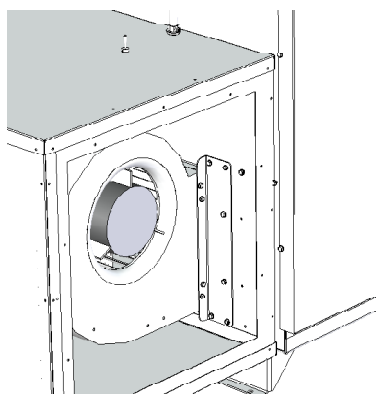
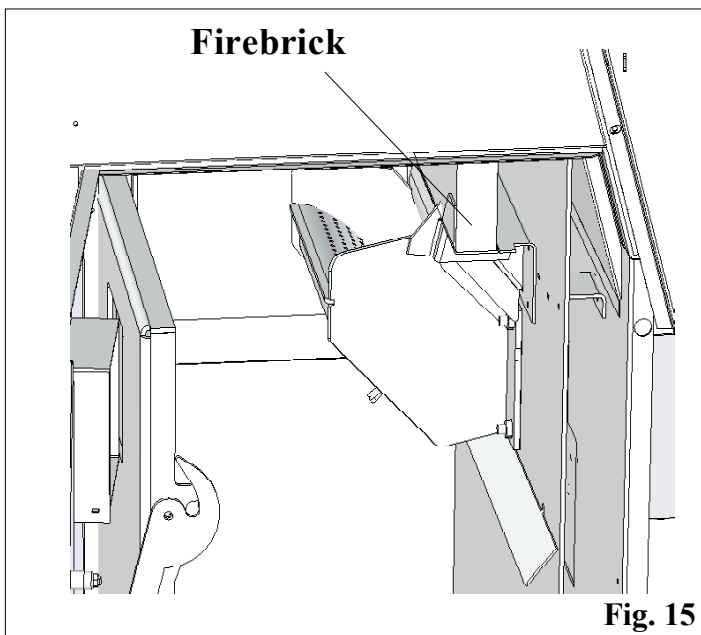

Fig. 14

3. Mount the filter box on the furnace with (8) 10 x 3/4 Tek screws, 3 on each side. Visually locate these holes so you are familiar with their location on the filter box and the furnace. Access to the mounting holes can be gained through the blower access panel cover and the filter opening. See Fig. 14.

Note: Two pieces of 2x4 stacked laying flat on the floor 12 inches from the blower opening will support the filter box during installation.



Firebrick installation-required

The firebrick is shipped in the ashpan. It will need to be placed on the brick shelf as shown in Fig. 15. It can be installed with either face to the fire. Hold the brick longways and slide it down into the slot on the shelf. There is a stop at the rear of the shelf to stop the rearward travel. The brick just sits on the shelf in the upright position.

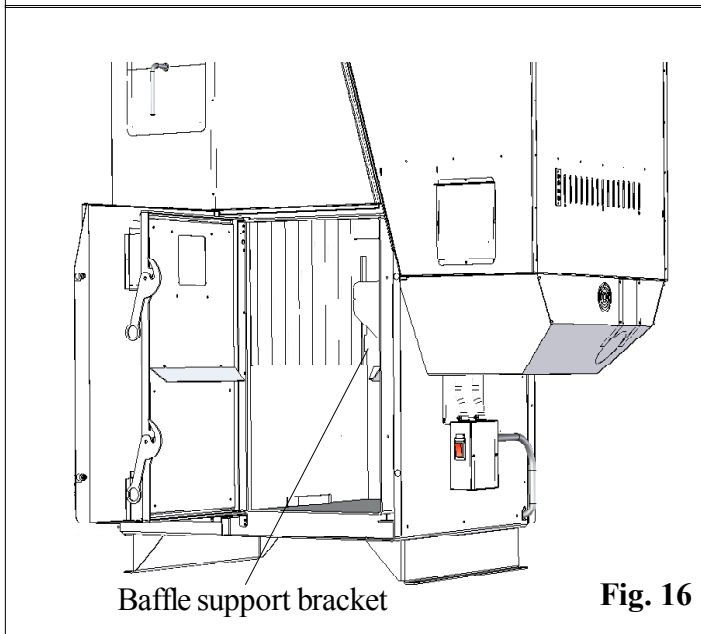

Baffle installation

The upper heat exchanger baffle comes shipped along side the ashpan. Remove the ashpan and the baffle. This upper baffle needs to be installed before operating the furnace.

The baffle has a long 45 degree bend on the bottom of the firebox side. See Fig. 17.

The top has a 90 degree bend on the same side to use as a handle.

On the opposite side there are four hooks that will support the baffle.

On the front and rear of the firebox walls there are brackets that these hooks fit into. See Fig. 16

Slide the upper baffle down on to the brackets, while you hold the baffle against the heat exchanger. You will notice that the upper baffle will hold the lower baffle plate into position. See Fig.17.

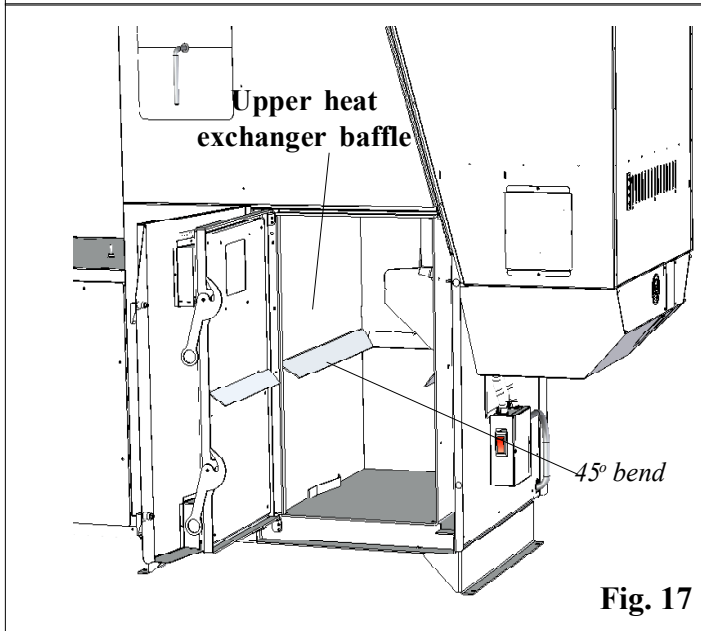

Note how the upper and lower baffles are held into position because they will need to be removed during heat exchanger cleaning.

Venting

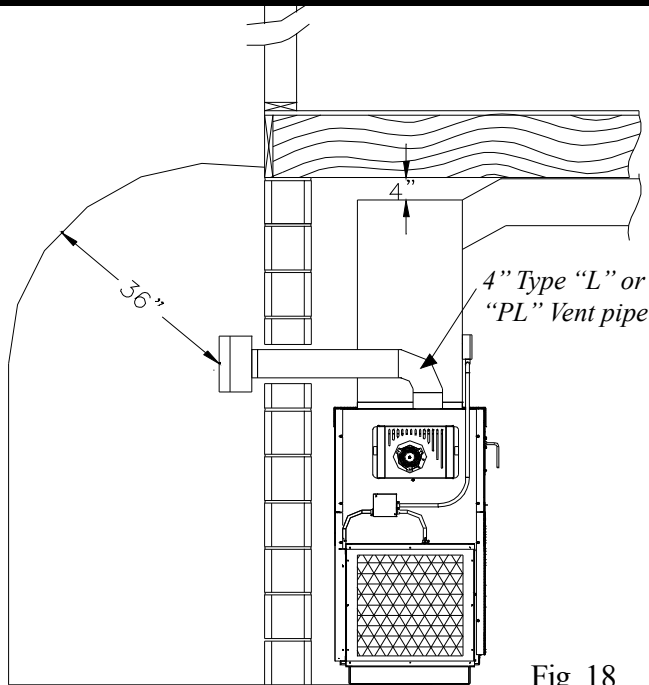

Fig. 18

This is the minimum venting configuration.

NOTE: This would only be allowed with **non-combustible** walls.

The minimum vent configuration is a 90° or Tee on a starter collar and a 24" length horizontal through an exterior wall. A cap or other bird screen on the end should direct the flue gasses down and away from the structure. See Fig. 18.

The maximum horizontal length is 18 feet. The minimum termination height above the exterior grade is 18". The maximum total length of any configuration is 30 feet*. * (see venting graph on page 13 for exceptions)

NOTE: Cleanout Tee's should always be used on the transitions to horizontal pipe to allow easy access for cleaning.

The venting graph allows for (one) 90 deg. or Tee fitting in any configuration.

If more 90's, T's, or 45's are needed the total length must be adjusted to allow for the added restriction.

Up to four (4) additional 90's, Tee's, or equivalent 45's can be added as long as the overall length is adjusted in accordance with the values listed below.

(See the venting graph on page 12.)

Each Vertical ---- 90 deg. or T subtract 2.5 feet

Each Vertical ---- 45 deg. subtract 1.5 feet

Each Horizontal - 90 deg. or T subtract 5.0 feet

Each Horizontal - 45 deg. subtract 2.5 feet

Any exterior venting (vent pipe exposed to outside ambient temperatures) should be kept to a minimum, due to potential condensation problems.

This is especially important in high humidity cold weather climates, such as maritime areas, lake shores, and low river valleys.

NOTE: Use only 4" diameter type "L" or "PL" venting system. Be sure to inspect and clean exhaust venting system frequently.

INSTALLATION IS TO BE PERFORMED BY A QUALIFIED INSTALLER.

DO NOT INSTALL A FLUE DAMPER IN THE EXHAUST VENTING SYSTEM OF THIS UNIT.

DO NOT CONNECT THIS UNIT TO A CHIMNEY FLUE SERVING ANOTHER APPLIANCE.

INSTALL VENT WALL PASS-THROUGHS AT CLEARANCES SPECIFIED BY THE VENT MANUFACTURER

NOTE: All installation clearances and restrictions must be adhered to.

NOTE: Read and follow all of the vent pipe manufacturers' instructions on the proper installation and support of the vent pipe. Adhere to all clearances.

WARNING

Keep combustible materials such as grass, leaves, etc. at least 3 feet away from the point directly under the vent termination. (between the vent and the ground)

WARNING

DO NOT INSTALL IN SLEEPING ROOM

CAUTION

KEEP COMBUSTIBLES AWAY FROM FLUE OUTLET.

Venting Configuration Graph

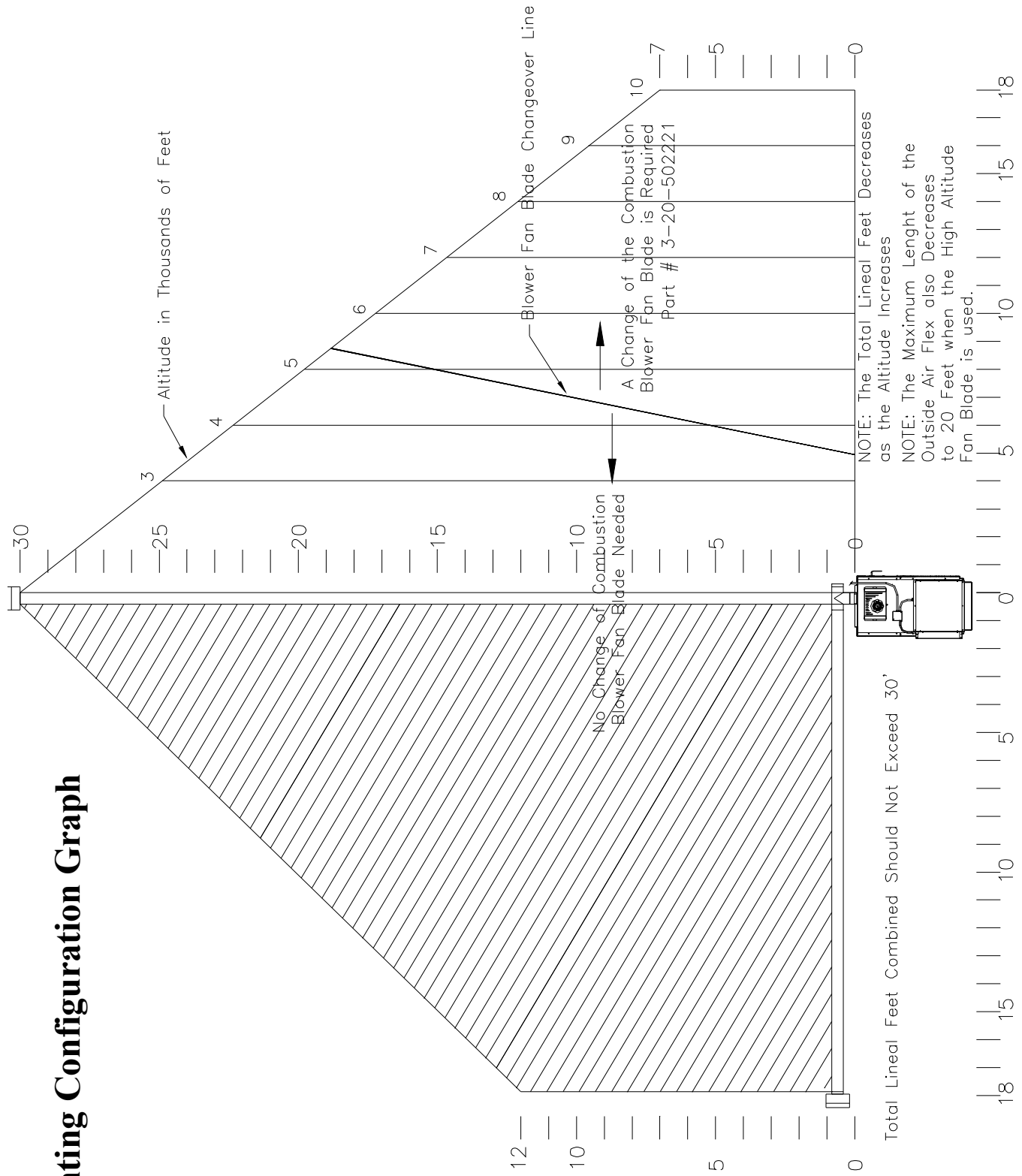

Fig. 19

Venting

Requirements for Terminating the Venting

WARNING: Venting terminals must not be recessed into a wall or siding.

NOTE: Only PL vent pipe wall pass-throughs and fire stops should be used when venting through combustible materials.

NOTE: Always take into consideration the effect the prevailing wind direction or other wind currents will cause with flyash and /or smoke when placing the termination.

In addition, the following must be observed:

A. The clearance above grade must be a minimum of 18".¹

B. The clearance to a window or door that may be opened must be a minimum of 48" to the side, 48" below the window/door, and 12" above the window/door.¹

(with outside air installed, 18")

C. A 12" clearance to a permanently closed window is recommended to prevent condensation on the window.

D. The vertical clearance to a ventilated soffit located above the terminal within a horizontal distance of 2 feet (60 cm) from the center-line of the terminal must be a minimum of 18".

E. The clearance to an unventilated soffit must be a minimum of 12".

F. The clearance to an outside corner is 11" from center of pipe.

G. The clearance to an inside corner is 12".

H. A vent must not be installed within 3 feet (90 cm) above a gas meter/regulator assembly when measured from the horizontal center-line of the regulator.¹

I. The clearance to service regulator vent outlet must be a minimum of 6 feet.¹

J. The clearance to a non-mechanical air supply inlet to the building or the combustion air inlet to any other appliance must be a minimum of 48".¹

K. The clearance to a mechanical air supply inlet must be a minimum of 10 feet.¹

(with outside air installed, 6 feet)

L. The clearance above a paved sidewalk or a paved driveway located on public property must be a minimum of 7 feet.^{1,2}

M. The clearance under a veranda, porch, deck or balcony must be a minimum of 12 inches.^{1,3}

NOTE: The clearance to vegetation and other exterior combustibles such as mulch is 36" as measured from the center of the outlet or cap. This 36" radius continues to grade or a minimum of 7 feet below the outlet.

¹Certain Canadian and or Local codes or regulations may require different clearances.

²A vent shall not terminate directly above a sidewalk or paved driveway which is located between two single family dwellings and serves both dwellings.

³Only permitted if veranda, porch, deck, or balcony is fully open on a minimum of 2 sides beneath the floor.

NOTE: Where passage through a wall, or partition of combustible construction is desired, the installation shall conform to CAN/CSA-B365. (if in Canada)

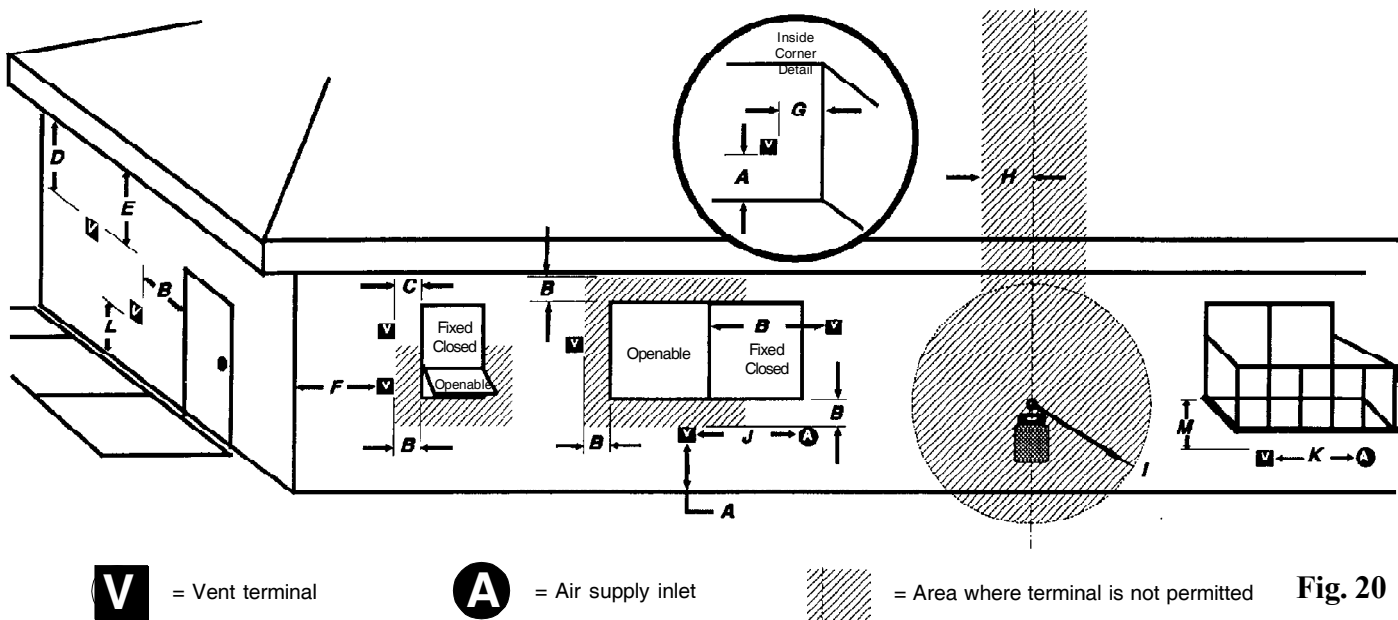

Fig. 20

Venting and Clearances

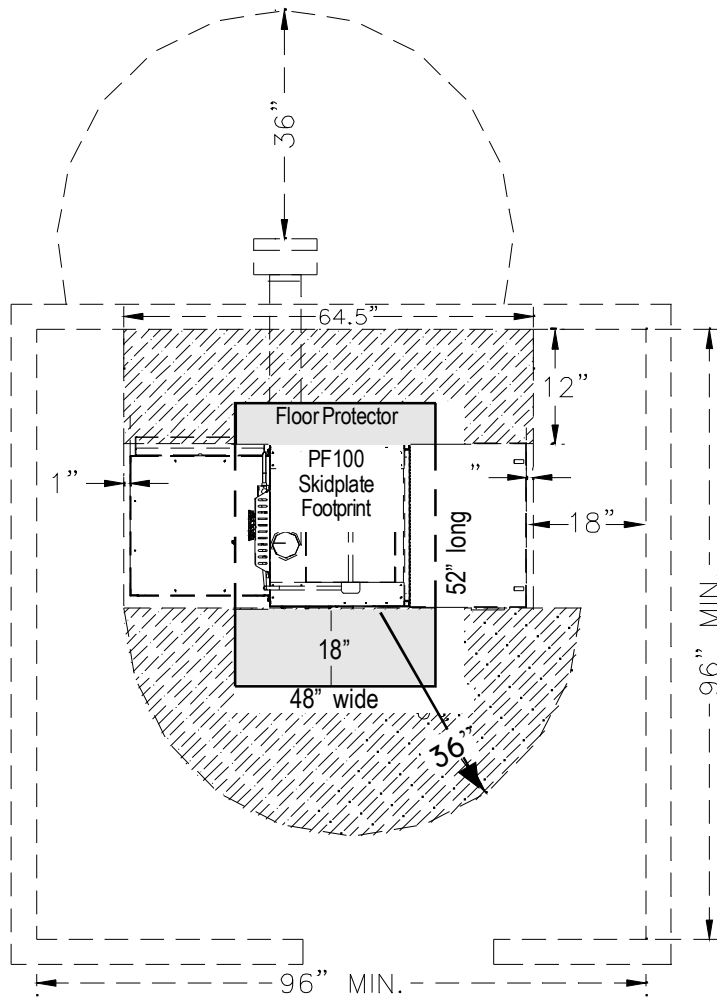

Fig. 21

Clearances to combustibles

If installing the furnace in a room separated from the remaining living spaces, the minimum size of the room must be no smaller than 8' x 8'. See Fig. 21. The reason for this is heat build-up and required space for service and normal operation.

This is the minimum size of the room even if it is built of non-combustible material.

High and low air vents **MUST** be installed between the room and the remaining living space. Each vent should be at least 72 square inches in area. (The vent size will need to be increased if there is no return air ducting system.)

The striped areas are the minimum clearances to combustibles which is 36" from stove body, not hopper or blower.

The shaded area indicates the required floor protection area. The PF100 requires 48" x 52" of floor protection centered around the skidplate footprint. Flooring should be a minimum of 26 gauge sheet metal covering the installation clearance area and 18" in front of, and 8" to either side of the ash pan door.

The 18" clearance on the hopper end is a manufacturer's recommendation for adding pellets and or servicing the feeder mechanism.

The minimum clearance to the top of the plenum is 4".

Note the minimum height to the bottom of the supply duct if it crosses the hopper.

The minimum duct configuration to a living space above the furnace is as shown in below. An offset of at least 24" **MUST** be installed between the plenum and the floor register. The register size **MUST** have an area of at least 240 square inches.

The minimum ceiling height is 6'6". This is set by the clearance to combustibles (28") from the top of the of the furnace. See Fig. 22.

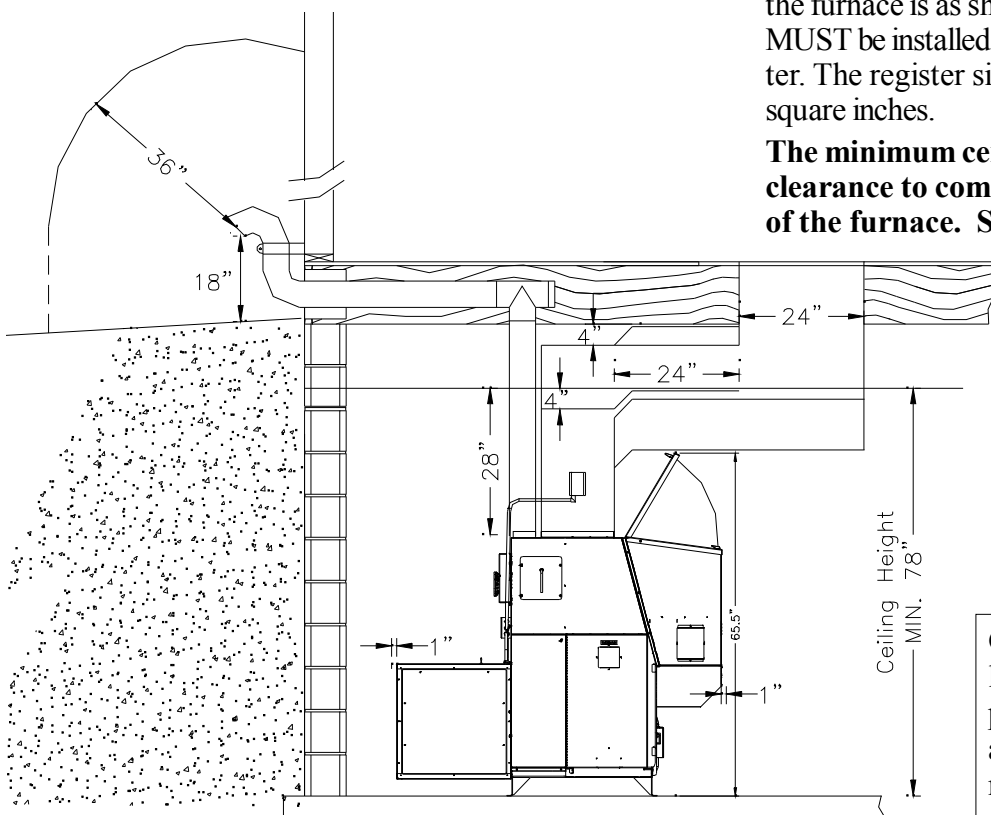

Fig. 22

NOTE: Install vent at clearances specified by the vent manufacturer.

CAUTION: When installing a floor register, the temperature of the discharge air **MUST** be taken into consideration (The discharge air temperature may be high enough to cause burns if not properly operated and maintained.)

CAUTION: The Blower Motor full load AMPS **MUST** be checked. A plenum damper may be required to adjust the motor full load AMPS to the motor nameplate rating.

Venting and Installation

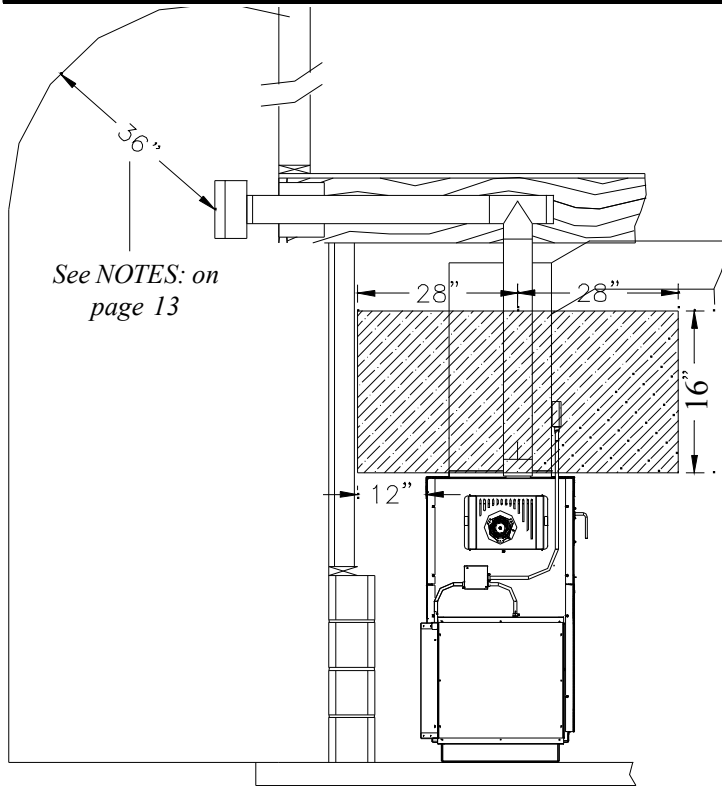

See NOTES: on page 13

Fig. 23

Chimneys taller than 20' above the connection will require a draft test to determine if the draft is too high.

Note: The High Burn Draft should not exceed .85 IWC. Some form of a restrictor plate may be required at the top of high chimneys to reduce the draft. See page 20 for the Draft Test procedure.

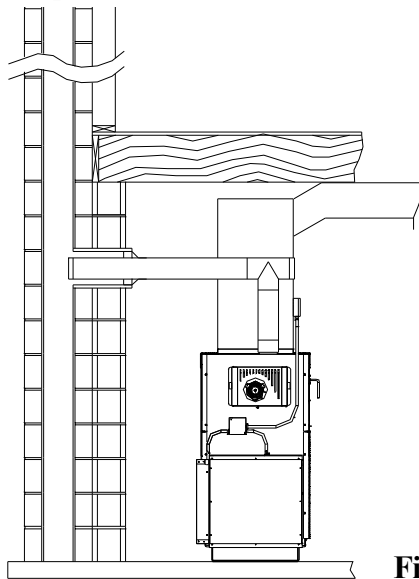

Fig. 24

Creosote - Formation and Need for Removal - When wood is burned slowly, it produces tar and other organic vapors, which combine with expelled moisture to form creosote. The creosote vapors condense in the relatively cool chimney flue of a slow-burning fire. As a result, creosote residue accumulates on the flue lining. When ignited, this creosote makes an extremely hot fire. The pellet vent pipe should be inspected at least twice monthly during the heating season to determine if a creosote buildup has occurred. If creosote has accumulated it should be removed to reduce the risk of a chimney fire.

Guidance on minimizing creosote formation and the need for periodic creosote removal: The chimney should be inspected during the heating season to determine if a creosote build-up has occurred. If a significant layer of creosote has accumulated (3mm or more) it should be removed to reduce the risk of a chimney fire.

The shaded areas are the clearances for the PL vent pipe that must be maintained at 3". After the venting leaves the shaded area it may be installed at 2" to combustibles. (Only listed 4" pellet vent wall pass-throughs and fire stops must be used.) See Fig. 23 & 25.

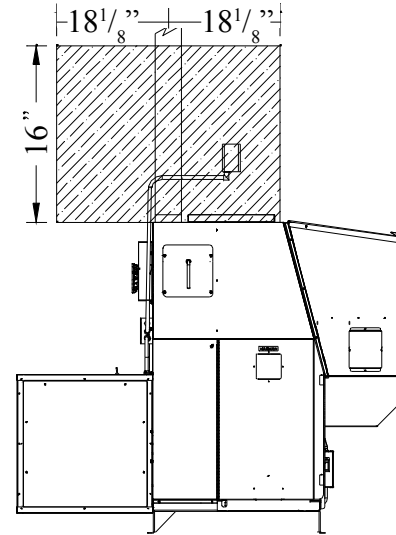

Fig. 25

The PF100 furnace may be used and installed into an existing masonry or Class A metal chimney.

Certain Canadian and Local Codes may require that the chimney be fully relined. See Fig. 24.

It Can Not be installed in a chimney serving another appliance.

The chimney should be cleaned and or inspected before installation.

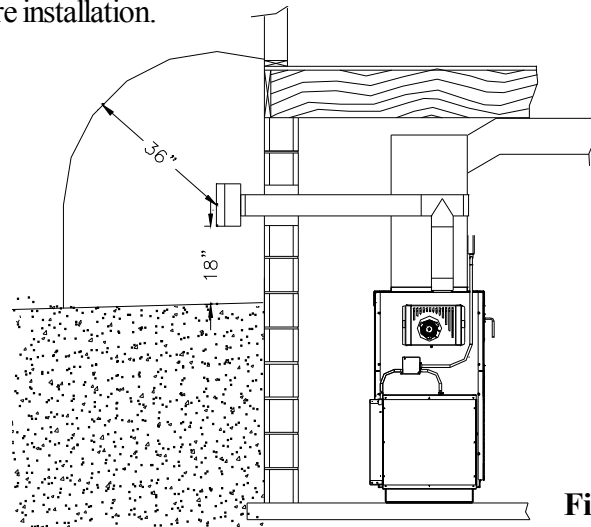
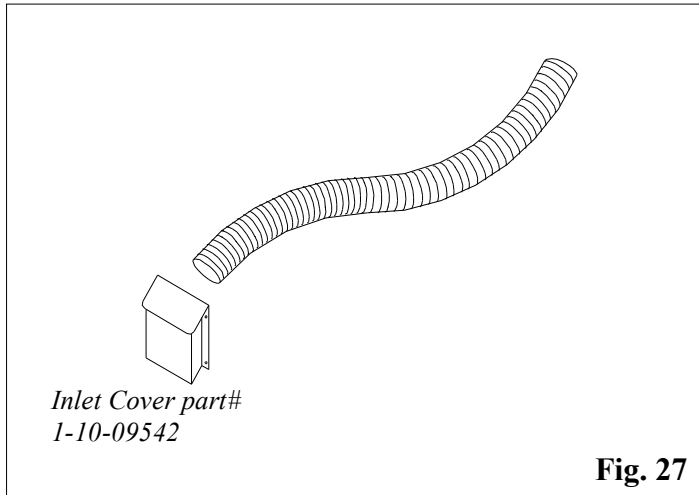

Fig. 26



Outside Air

Outside air is optional, although it may be required by some building codes. The benefit of outside air is higher efficiency and reduced venting restrictions mainly noticed in small and very tight houses.

To install outside air, use 2 3/4" I.D. galvanized steel flex pipe, part # 2-00-08544 (12' 6" length) or part # 2-00-08545 (25' length). There is a break-away hole on the rear panel which must be removed before connecting the flex pipe. See Fig. 28. The pipe should be run outside and terminate 3 feet or more below or 1 foot or more to the side of the vent pipe outlet. Never terminate the outside air above the vent pipe outlet. The maximum length of this pipe is 25 feet. Inlet cover part number 1-10-09542 should be used to keep birds, rodents etc.out of the inlet pipe. See Fig. 27.

NOTE: If outside air is installed, the inlet cover should not be placed in an area where drifting of snow or ice will build up, blocking the intake air supply.

The Outside Air knockout is located on the face of the Feeder Cover. It is pre-cut except for several small tabs. There is also a filler plate screwed to the inside to cover the top of the hole after the Outside Air Pipe has been installed. This will allow for removal of the Feeder Cover without disconnecting the Outside Air Pipe. See Fig. 28.

Only metal Intake Flex should be used for the Outside Air Supply connection.

Only a screened or rodent protected Outside Air Intake cover should be used as an outside weather cover.

The Outside Air Intake Pipe is inside the Feeder Cover and to the right of the feeder motor. The 2 3/4" steel flex pipe is made to slide over the outside of the Air Intake Pipe. See Fig. 29. It should be held into place with some silicone, foil tape, or a hose clamp. (not supplied)

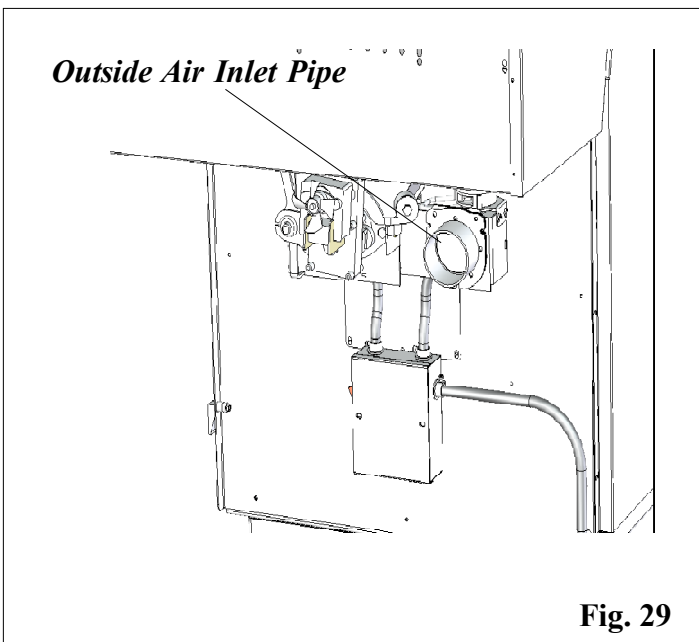
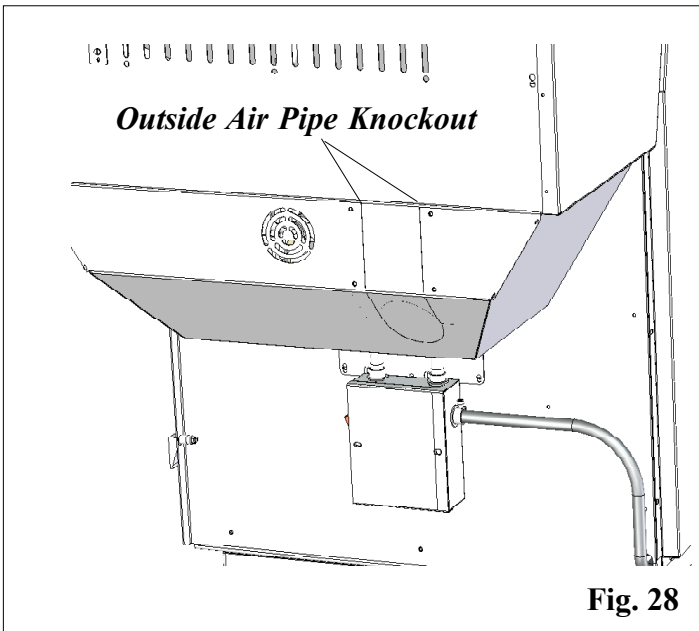

HRV

When installing in a house with a Heat Reclaiming Ventilation System (HRV) be sure the system is balanced and is not creating a negative pressure in the house.

Note: If the furnace is installed with the outside air system no adjustments to the HRV should be necessary.

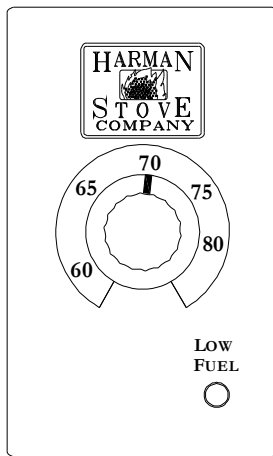

Fig. 30



Fig. 31

Datacom Cable	Wall Control	
Orange -	Red	(+ LED)
Blue/White -	Blue	(Tstat)
Orange/White -	White or Black	(- LED)
Blue -	Blue	(Tstat)

Fig. 32

Wall Control Wiring

The Wall Control sends and receives its information from the control board through a 4 wire Datacom cable. There is a 100' length of this cable supplied with the furnace. 100' lengths of this cable can also be ordered separately, part # 3-20-02583. Or any Datacom cable -CAT 3 - 2 twisted pair 24ga solid wire can be acquired at a local electrical supply house. Also any CAT 3- 24ga. solid wire 2, 3, or 4 pair cable can be used because they all have the same pair color combinations. The maximum length of wall control wiring is 200 feet.

The furnace connecting point is a 4 pole screw terminal block on the side of the hopper just around the corner to the right of the control. Follow the wiring instructions on the label alongside the terminal block. See Fig. 31.

CAUTION: With this small of wire gauge, care must be taken not to overtighten the terminal screws, thus breaking the wire.

There are tie-wrap holes in the face of the hopper approx. every 6" to keep the cable secure and out of the way.

The Wall Control is made to fit on a standard wall case electrical box. It could also be mounted directly to a stud using 2 drywall screws. In either case the screws should be turned in and tested for a snug fit when the Wall Control is slid down over the screws. The Wall Control only hangs on the screws so a good fit is important.

Remove the Wall Control and make the Datacom cable connections with the UY auto splicers provided. **DO NOT STRIP THE WIRES.** Following the wiring diagram on the inside of the Wall Control make each splice. See Fig. 32. Insert the two matching color wires fully into the two holes of one of the UY connectors. A pair of standard Channel-lock pliers works ideally to squeeze the raised button down into the UY connector body. Extra UY connectors can be purchased. Part # 3-20-00200

NOTE: A pair of needle nose pliers may be necessary to insert the BLUE T-stat wires fully into the connector. Visually inspect to see that the wires are fully inserted before squeezing the UY splicer.

NOTE: The PF100 furnace Can Not be installed with any other brand or type of wall thermostat.

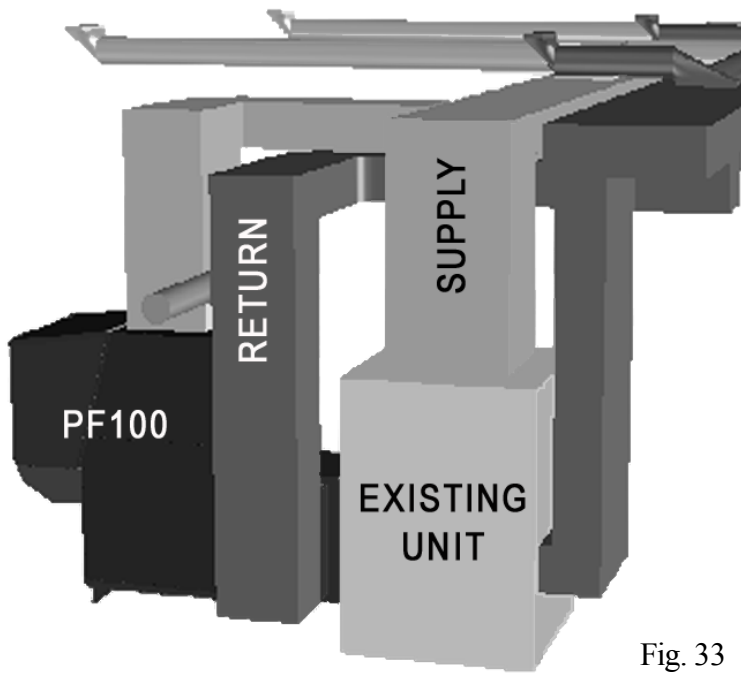

Fig. 33

The Harman PF100 may be connected to a gas or oil-fired central furnace or heat pump duct system. Prior to installation, determine whether all requirements for installation including all clearances can be met.

The PF100 warm air supply and the cold air return must be installed in a parallel arrangement. **EXAMPLE:** The warm air supply duct from the PF100 is to be connected to the warm air supply of the existing furnace. Also the cold air return duct from the existing furnace is to be connected to the cold air return duct of the PF100. Isolation dampers (2) should be installed in the ductwork. (1) in the warm air supply duct for the existing furnace and (1) in the warm air supply duct of the PF100 after or “downstream” of the high limit/fan control. These dampers can be manually operated or fully automatic. In either case, the unit that is not being used must be prevented from being operated. (This also can be done manually or automatically.) **NOTE:** Any control wiring, power wiring needed should be performed by a qualified installer and/or electrician.

The warm-air supply outlet of the PF100 shall not be connected to the cold-air return inlet of the central furnace because a possibility exists of components of the central furnace overheating and causing the central furnace to operate other than as intended.

We recommend that the warm air supply plenum be constructed of sheet metal.

Installing Duct

Recommendations for Supply Air and Return Air duct sizing.

The speed or velocity of air moving through duct systems increases as the duct decreases in size with the same CFM blower. The sound of air flowing through the duct increases as the velocity increases. Therefore the largest size duct practical should be used.

The velocity to sound level must be taken into consideration when connecting this furnace into an existing duct system.

As a primary source furnace the duct system can be installed to fit the customers needs.

These are recommended Supply Air duct sizes (in square inches) for the different CFM blowers that may be used with this furnace.

Velocity I.W.C.	500fpm .3 min.	700fpm to	900fpm .6 max.	Static
1000CFM	270sq.in.	210sq.in.	160sq.in.	
1500CFM	360sq.in.	290sq.in.	220sq.in.	
2000CFM	470sq.in.	360sq.in.	290sq.in.	

(These duct sizes are only recommendations.)

The Return Air duct system should be sized approx. 10 percent larger for heating only systems and 20 percent larger if airconditioning is installed.

Adding Air Conditioning to the PF100 furnace.

An easy rule of thumb for A/C CFM blower size is, .75 to 1 CFM for each square foot of conditioned space. (std. 8' ceiling height)

The PF100 furnace can be fitted with an air conditioning coil mounted in the supply air plenum.

The Harman Stove Co. is not responsible for sizing, duct placement, or interconnections. However we have made adding A/C to the furnace easier with the information listed below.

There is a factory installed junction box ready to accept your A/C relay. The A/C fan control center with 40 va transformer must have a DPDT relay. STEVECO # 90-112 - Harman part # 3-20-38056 Other brands are available at local supply houses.

The wiring should be done as per Fig. 34. The low voltage wiring to the outside condensing unit and the cooling thermostat are not shown, see condensing unit diagrams for that information.

This style relay is used to lock out the feeder system of the furnace when the A/C unit is calling for cooling. This is a fail-safe against both units operating at the same time. See the **NOTE** in the lower left corner.

CAUTION: Regardless of the supply air duct size installed the Distribution Blower Motor **MUST** be checked for running Amperage. Check the motor name plate for the full load AMPS. If the amperage is running higher than that listed, a supply air restricting damper may be required to increase the supply plenum positive static pressure.

NOTE:
It is highly recommended that the furnace control be turned to the "OFF" position whenever air conditioning is being used, whether or not it is interconnected.

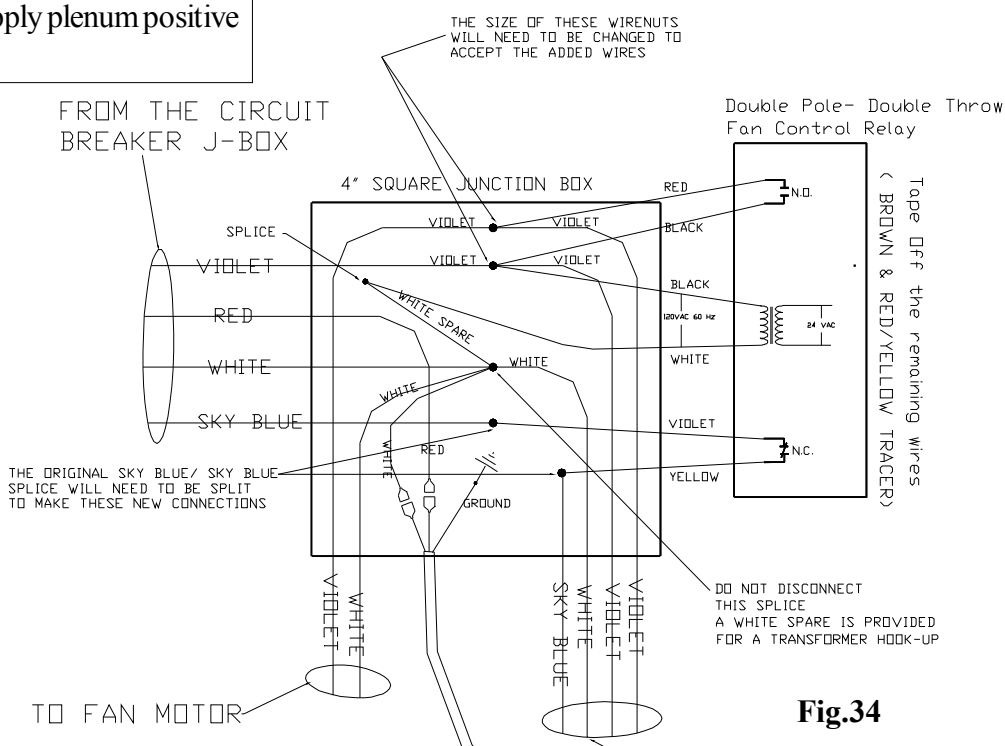
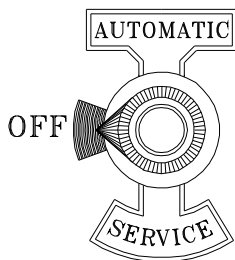

Fig.34

FAN/HIGH LIMIT CONTROL

Installation & Set-up

1. The Fan Control must be placed in the discharge plenum approximately 11 inches above the discharge opening of the furnace as close to center as possible.

Note: The best place is on the same side as the ash door because of ease of access. See Fig. 35.

Note: Care must be taken when installing the Fan Control when an air conditioning A Coil is used. The Fan Control **must** always be installed below the A Coil in low plenum installations.

2. Install the flex and wiring.

3. Make sure that the flue venting will not interfere with the flex to the Fan Control.

4. Pry out one of the bottom knockouts of the Fan Control. Install the 90 degree flex connector as shown in Fig. 36. One of the locknuts stays on the outside of the box and one goes on the inside to tighten the connector into place. This allows for maximum room for the wires around the switches.

5. **REMOVE THE COPPER JUMPER BETWEEN THE LIMIT AND CONTROL SWITCHES. (It is not needed.)** Figure 36 shown with copper jumper that has already been removed.

6. Connect the two VIOLET wires to the FAN CONTROL switch. (It doesn't matter which wire is on which screw). See Fig. 36.

7. Connect the WHITE and SKY BLUE wires to the LIMIT switch. (It doesn't matter which wire is on which screw). See Fig. 36.

8. Make sure that all of the wires are out of the way when closing the cover. (Excess twisting and pinching of the wires could cause a short circuit.)

9. HIGH LIMIT setup is simple, just rotate the high limit pointer clockwise until it is against the tamper-proof screw. (Never adjust this screw)

10. FAN CONTROL setup: Move both fan control pointers together until they touch, then rotate both pointers together until the gap between them is directly over the middle 0 of 100. See Fig 36.

Note: This is the best fan control position we have found during factory testing. These fan control limits can be adjusted if desired.

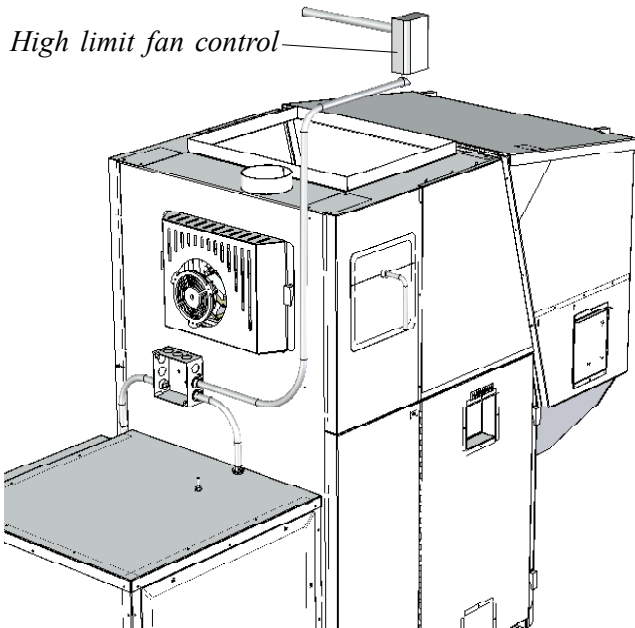

Fig. 35

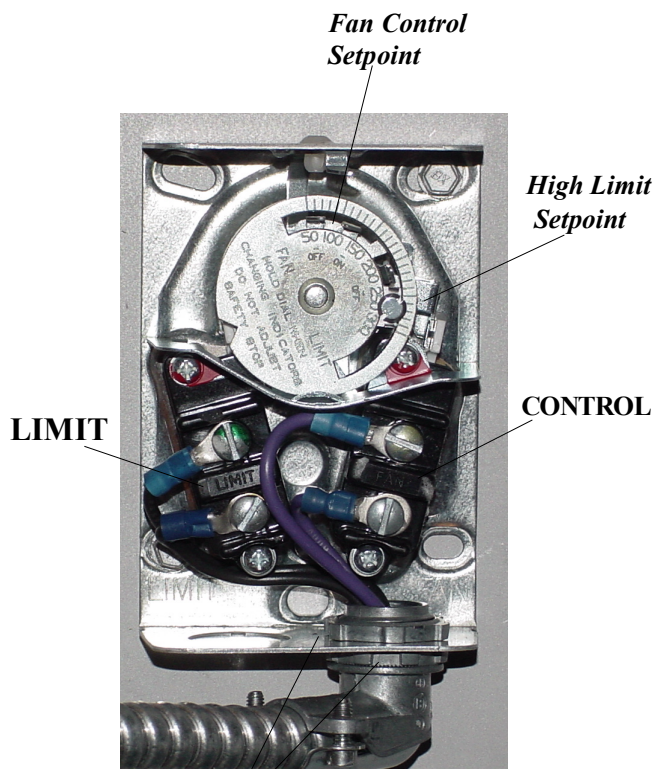

Fig. 36

NOTE: KEEP THE FAN/LIMIT CONTROL INSTRUCTIONS WITH THE OWNERS MANUAL FOR FUTURE REFERENCE.

NOTE: If fans are used in the fuel storage area, they should be installed so as not to create negative pressures in the room where the solid-fuel-burning appliance is located.

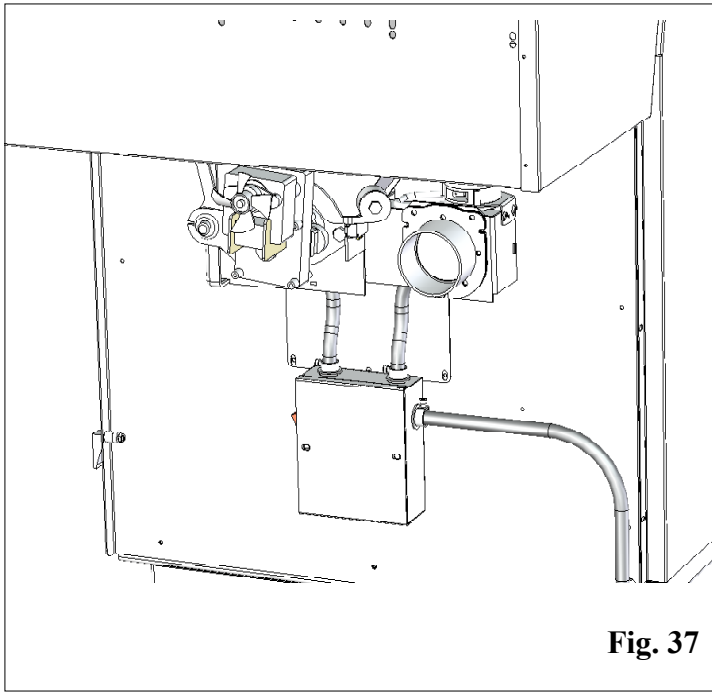

Fig. 37

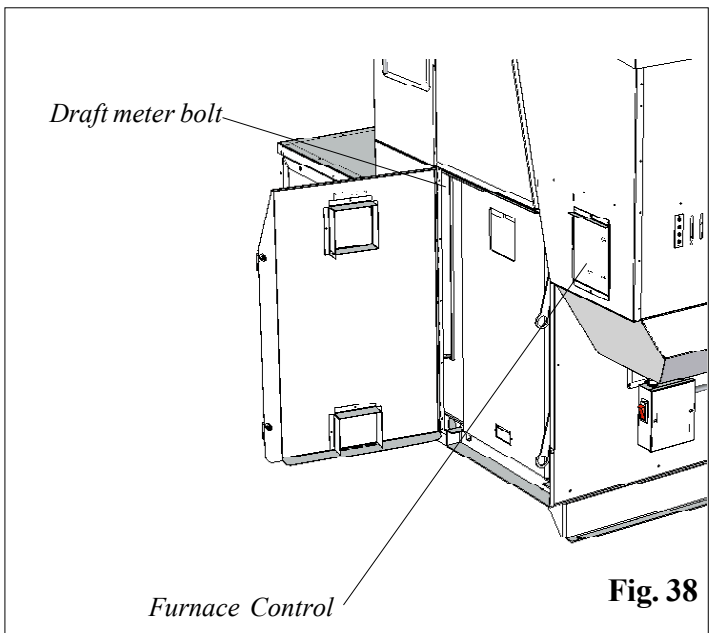

Fig. 38

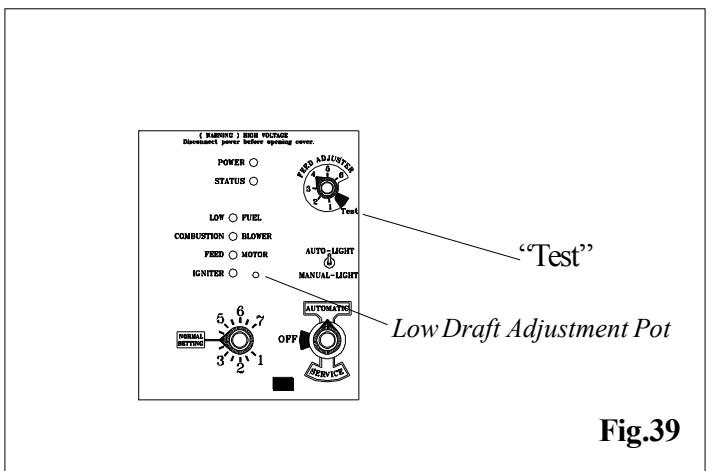

Fig.39

Installing Electrical Power:

To install power to the furnace first remove the cover on the circuit breaker junction box shown.

Inside you will find the main terminal block. (See wiring diagram on page 36 for location of main terminal block and proper power connections). In the bottom of the box a knockout hole is provided for the incoming wire.

The **minimum** recommended circuit is 15 Amp 120 V.A.C. 60 Hz. This furnace should be the only appliance on the circuit.

This furnace should never be powered by the use of an extension cord.

The recommended high and low voltages are, 130 V.A.C. 60 Hz maximum high voltage, and 113 V.A.C. 60 Hz minimum low voltage.

The furnace will continue to operate at voltages as low as 105 V.A.C. , although it can not be guaranteed that automatic ignition will occur. Also there is the possibility of a distribution blower motor overload.

NOTE: If other sources of electrical power are to be used (such as a generator) for normal operation or emergency operation, this source should be checked before installation. Many generators and inverters may not supply 120V.A.C. 60Hz. power stable enough to operate the control board properly. (Control board damage could occur). Checking & Recording the Low Draft:

After the venting is completed, the firebox low draft will need to be checked and possibly adjusted. After removing the 3/8" bolt from the draft hole shown in Fig. 38, insert the draft meter tube. The inner ash door and the hopper lid must be latched during this test. (It is recommended that the draft meter have a scale of 0 to 1" WC.)

Turn the Furnace Control to "Test". this will start the combustion blower and allow you to check and record the High Draft _____ - IWC date _____ (There is no adjustment for the High Draft)

After the first 60 seconds the "Test" mode lowers the combustion blower voltage to the Low Burn voltage. (The "Test" mode cycles the voltage from high to low every 60 seconds). During this lowered voltage cycle the **Low Burn Draft must be checked** and adjusted if necessary. The recommended low draft setting should be between -.25 & -.35 IWC. Depending on the amount of vertical rise, it may not be possible to get a low draft reading in this range. In this case, a maximum low draft of -.55 is acceptable.

The adjustment screw is through the small hole to the right of the Igniter Light. See Fig. 39. Adjusted the Low Draft to _____ -IWC.

Don't forget to turn the control back to #4.

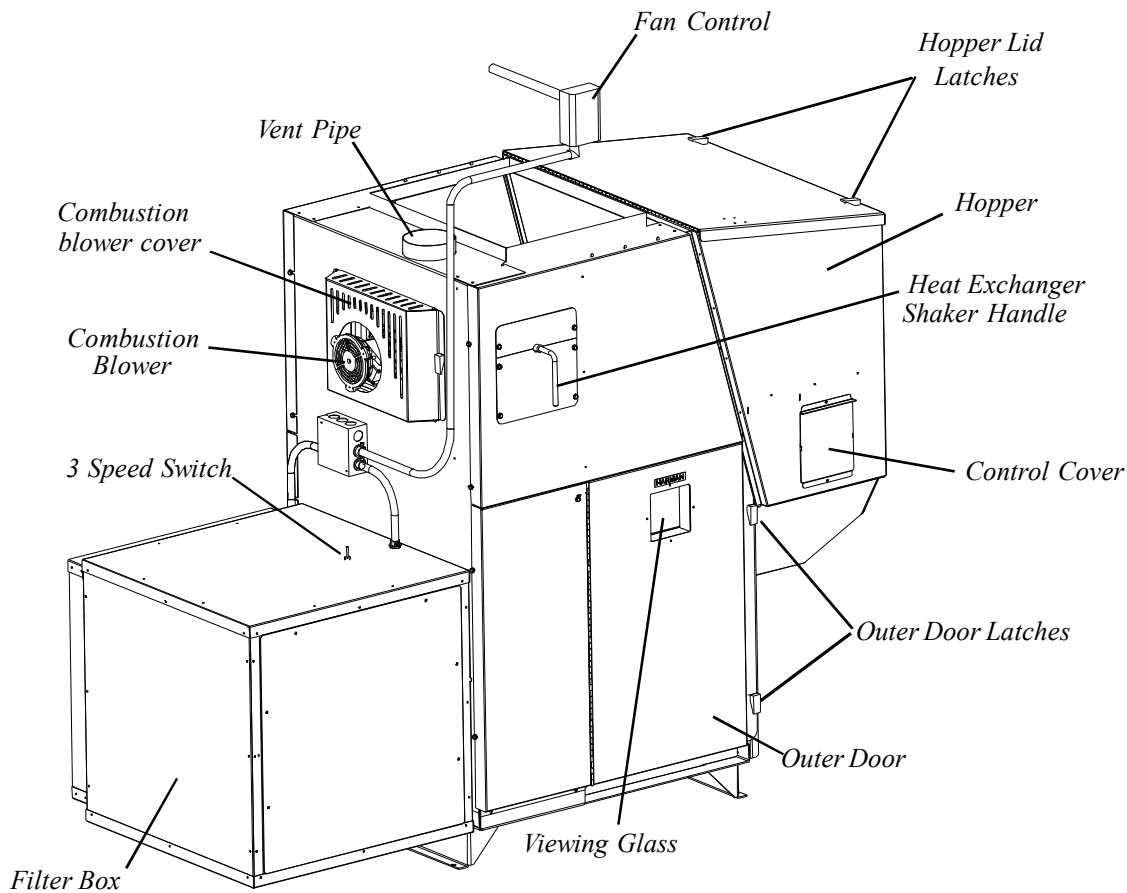

Fig. 40

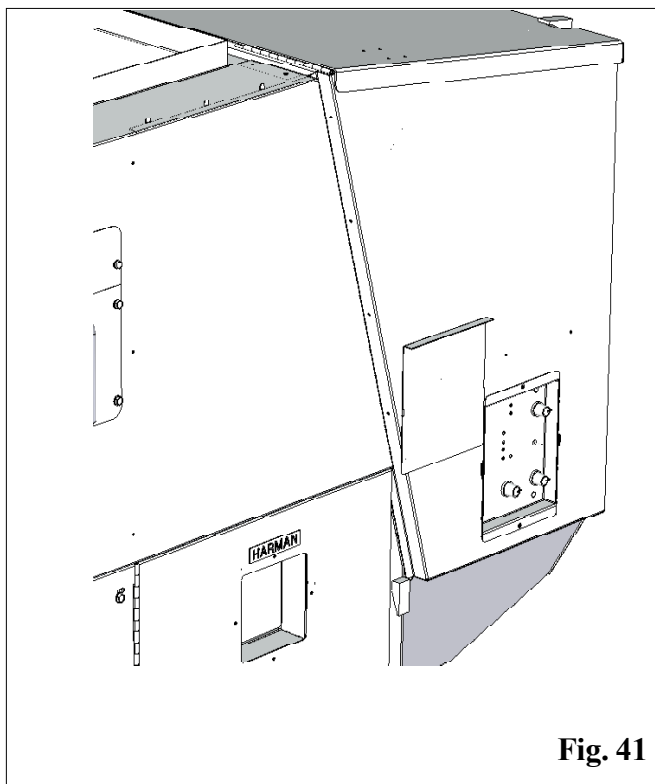

Fig. 41

The Control

The control can be covered as shown above, or uncovered as shown at left. There is a pair of slots provided for each position. Simply move the cover to the desired position by placing the tabs on the cover in the proper slots.

CAUTION: Hot while in operation. Do not touch. Keep children, clothing, furniture, and other combustible material out of the installation clearance area.

WARNING: Do not operate with fire chamber or ash removal doors open.

WARNING: Do not store fuel or other combustible material within installation clearance area.

Operation

Power Light

Indicates power to the control, and is also used during "Test" to check the Low Fuel Sensor operation.

Status Light

Will be lit in either automatic or service mode when pointer is not within off position band except after normal shut down. It also blinks to indicate errors listed below.

Low Fuel Light

Indicates that fuel in the hopper is low and needs to be refilled.

Combustion Blower Light

Indicates Power to combustion blower

Feed Motor Light

Indicates Power to the feed motor.

IgnitEr Light

Indicates power to the ignitor

Temp dial

The "Temp Dial" should be in the "Normal Setting" position except when service work is being done. It also allows you to adjust the fire temperature when the "Mode Selector" is in "Service Mode" using the scale marked from 1 to 7.

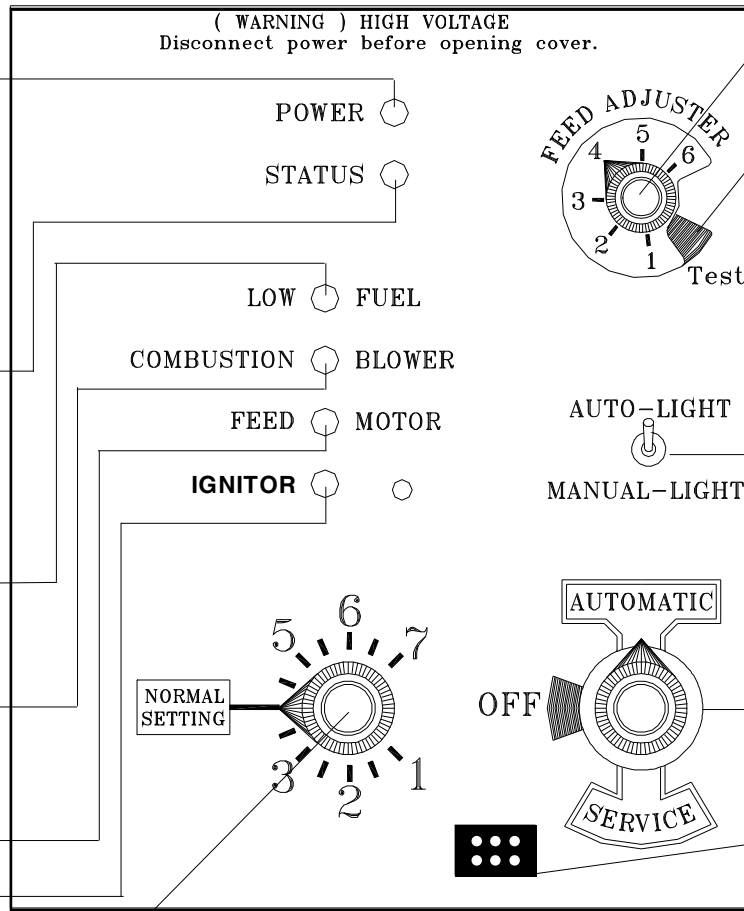

Fig. 42

Feed adjuster

Sets the maximum feed rate

Test

Runs all motors ** at full speed for one minute to check operation. After one minute the furnace will go to minimum burn and the combustion blower will alternate from high to low every minute to remind you that you are still in "Test Mode".

Lighting Mode Selector

Switched between Auto and Manual lighting

Mode Selector

See explanation below.

Dealer Diagnostic Port

For dealer maintenance only. Requires special DDM monitor supplied to Harman Dealers exclusively.

Status light error messages:

1 Blink: Indicates control board self diagnostic failure. This requires a manual reset*.

3 Blinks: Indicates ESP (Exhaust Sensing Probe) failure. This requires a manual reset*.

4 Blinks: Can occur only in the Automatic Mode and indicates the Wall Control has failed or is not installed. If a Wall control is then installed the status light will automatically reset. (Note) only after the unit has warmed up.

5 Blinks: (In Auto Light Mode Only)

Indicates that the igniter has failed to light the fire after 4 consecutive 8 minute attempts. To reset - Turn the Mode Selector to OFF and then back to Automatic.

6 Blinks : Indicates that the control has calculated poor or incomplete combustion occurring for more than 50 minutes. A six blink status may be set if the stove is allowed to run out of pellets. To reset, turn mode selector to "OFF" then back on to the desired mode. If the unit was not out of pellets, see Troubleshooting section, Page 35, for more details.

* **Manual reset,** disconnect power at the circuit breaker for a few seconds and reconnect. If error still occurs call your Dealer.

22 PF100

Mode Selector

Allows you to choose between Automatic Mode, Service Mode or OFF.

Automatic Mode

Automatic mode switches operational control of the furnace to the wall mounted control. This is the mode to use whenever the furnace is burning in a normal heating application.

Service Mode

Service mode switches control of the furnace to the temp dial. The temp dial can be set from 1 to 7 to allow a steady furnace temperature at the desired level. The main purpose of this mode is to operate the furnace without having to go back to the wall mounted control.

OFF Mode

Turning the mode selector to OFF will shut down the furnace.

** The Distribution Blower is not controlled by the "Test" operation. The Distribution Blower has its own Manual Test Switch on the Fan / High Limit Control cover.

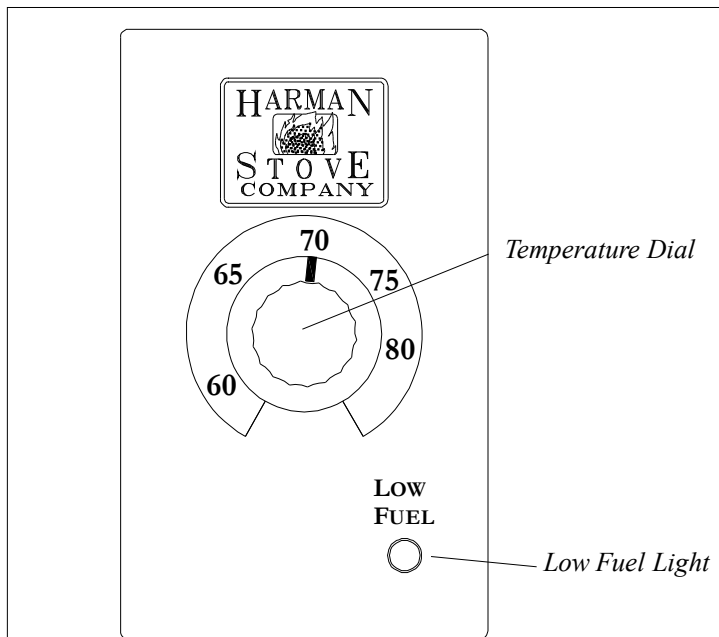

Fig. 43

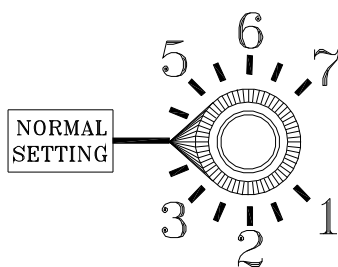

Fig. 44

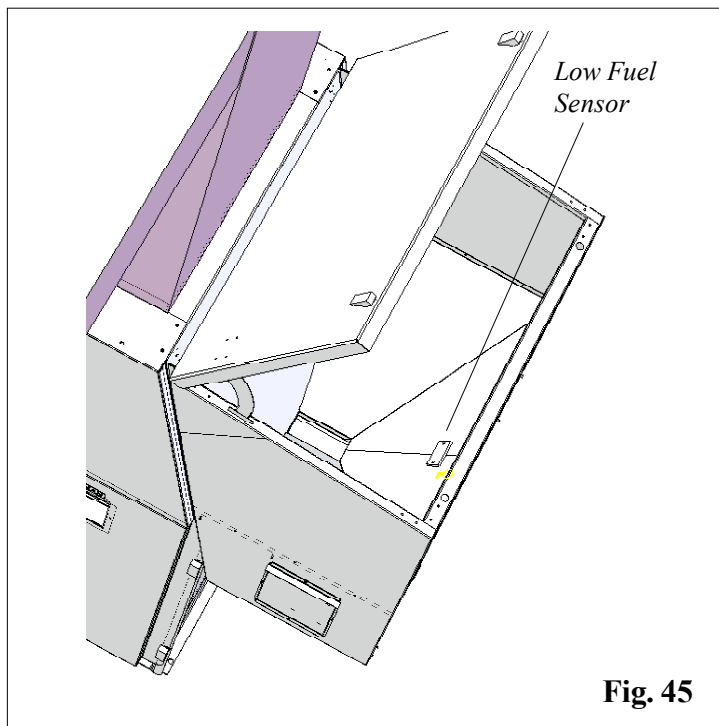

Fig. 45

Wall Control

The wall control acts like a thermostat, however, what is actually going on is a thermister in the wall control is sending temperature information back to the micro processor on the furnace. This information is used to increase or decrease the size of the fire according to the needs of the home.

Setting The Room Temperature

To set the room temperature, simply turn the temperature dial to the desired setting. The control and the furnace will then perform to achieve the set temperature.

Note: The minimum temperature you can set with a full counter-clockwise knob position is 58 degrees. The maximum temperature you can set with a full clockwise knob position is 90 degrees.

Wall Control calibration: The "Normal Setting" on the Temp Dial of the Furnace Control (See Fig.44) calibrates the Wall Control temperature span. If the Temp Dial is not pointing to the "Normal Setting", the temperature span could vary by 3 degrees up or down depending on the Temp Dial knob setting.

Low Fuel Sensor

There is a low fuel sensor in the hopper that tells the control that the fuel level in the hopper has dropped below the sensor. When this happens, the Low Fuel light on the Wall Control will start to blink. You then know that it is time to fill the hopper with pellets.

Note: Testing the low fuel sensor can be done by turning the FEED ADJUSTER knob to "Test". The POWER light will go off when the sensor is uncovered and will light when the sensor is covered again.

Note: The LOW FUEL light on the Furnace Control will light at the same time. Only the LOW FUEL light on the Furnace Control will remain lit for three minutes after the sensor is covered with pellets. See Note below.

Note: The Low Fuel light indicates that there is power going to the auxiliary leads in the circuit breaker junction box. (120 VAC 60 Hz Max. 1 Amp.)

The auxiliary power leads would be used if an optional bulk hopper and auger system were installed. (see wiring diagram on page 36)

Type of Fuel

Pelletized wood only. **Note:** The lower the ash content of the pellets the less cleaning that will be needed of the heat exchanger surfaces. The cleaner these surfaces are kept, the more efficient the furnace will be.

Starting A Fire Automatically

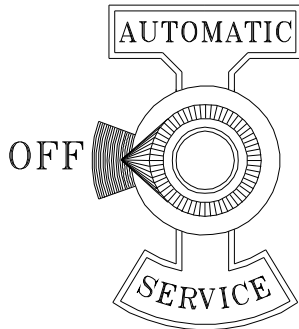

Fig. 46

1. Turn Mode Selector to "OFF".

This resets the control in addition to turning it off.

2. Fill hopper with pellets.

When filling the hopper check for excessive fines in the bottom of the hopper. Fines are small pieces of broken pellets (sawdust). Fines do not flow easily and often build up on the hopper funnel bottom angles. These fines can be pushed into the feeder opening and then fill the hopper with pellets. As the system works, they will be burned.

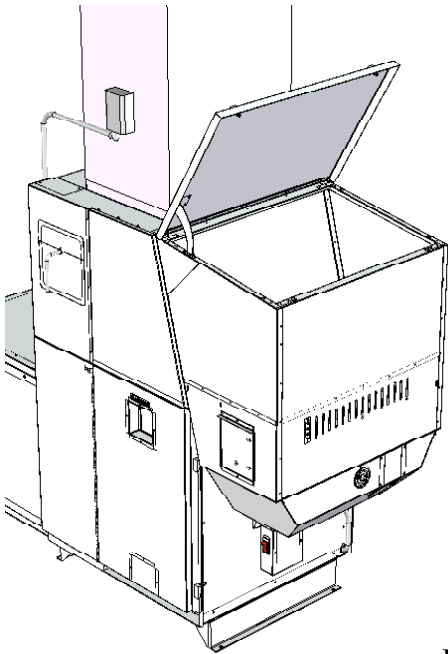

Fig. 47

3. Clean burnpot with scraper, if necessary.

This is usually a weekly maintenance procedure. Cleaning the burn pot with the scraper with a small amount of new fuel in the bottom is not a problem. First, scrape the ashes on the front of the burn pot into the ash pan. Then scrape the hole grid surface downward into the burn pot. When the stove is ignited these scrapings will be pushed out by the feeder.

Note: If the Distribution Blower is running when the outer door is open, some air will escape around the door opening. This is not a problem, however, any dust that is caused in the process can potentially be blown around.

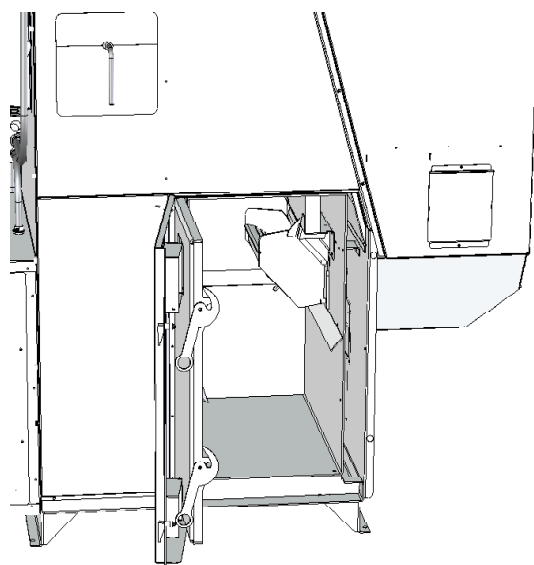
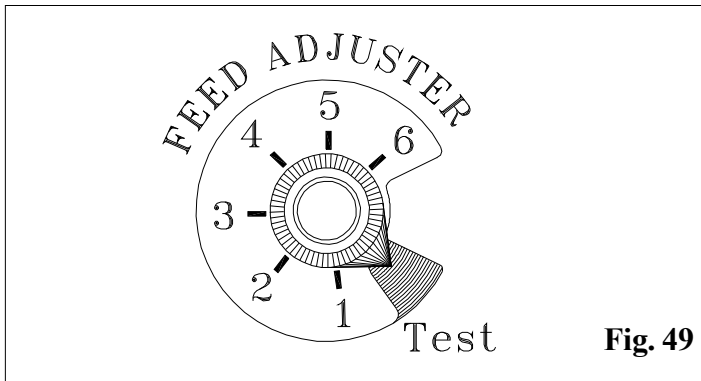
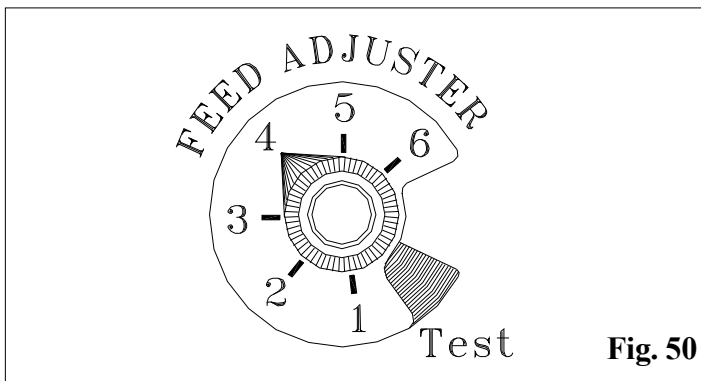

Fig. 48

Operation



4. If starting after an empty hopper, turn Feed Adjuster to "TEST" (for one 60 second cycle). This will purge pellets into the auger tube and also allow you to check the motors for operation. **NOTE: The auger motor will not operate with the ash door open.**



5. Turn Feed Adjuster to #4.

If this is your first fire or you are trying different pellets, set the feed adjuster to #4, Fig. 50 This is a conservative number and will probably need to be increased if maximum BTU output is desired. After you know a feed rate setting that works well for your application, use that setting. Remember, if your feed rate is too high you may waste fuel due to overshooting the Wall Control setting.

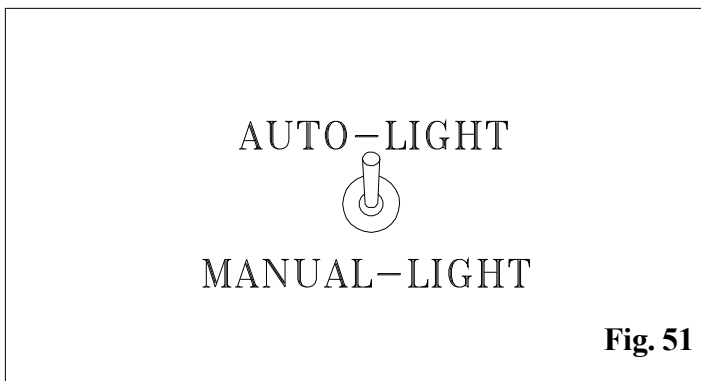

6. Flip the Igniter Switch up into the "AUTO-LIGHT" position.

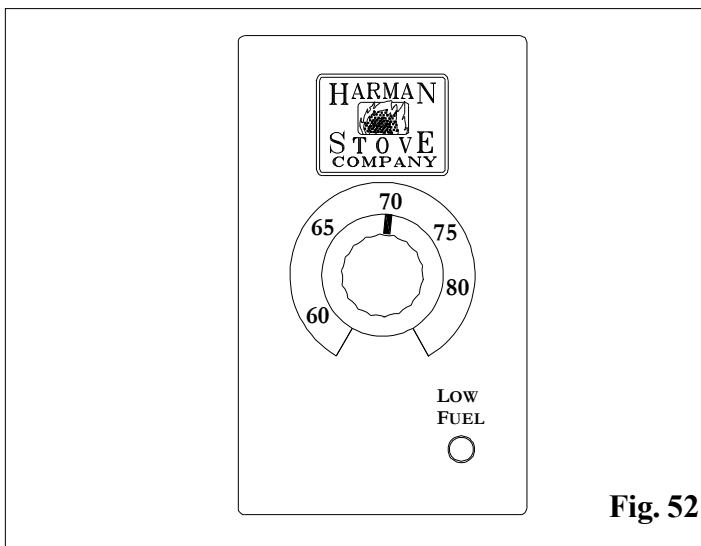

7. Turn the Temperature Dial on the wall control to desired room temperature. Note: The set temperature on the dial must be higher than the room temperature for the fire to light.

WARNING: HOT WHILE IN OPERATION. KEEP CHILDREN, CLOTHING, AND FURNITURE AWAY. CONTACT MAY CAUSE SKIN BURNS.

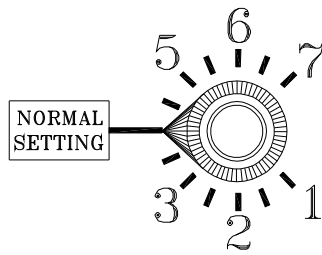

Fig. 53

8. Turn the **Temperature Dial** on the furnace control to “NORMAL SETTING”.

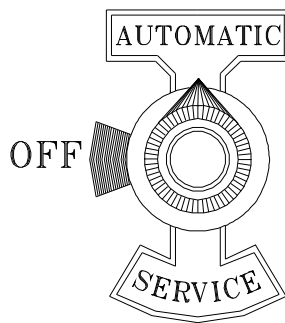
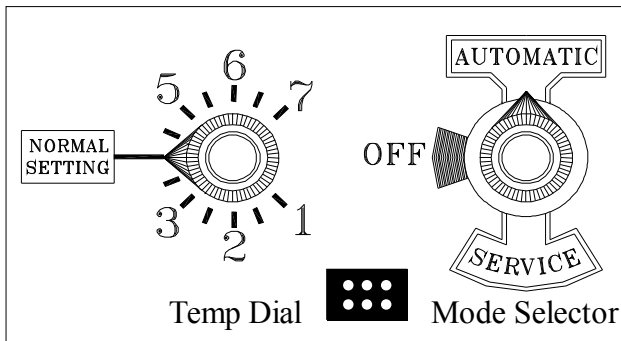

Fig. 54

9. Turn **Mode Selector** to “AUTOMATIC”

This will start the lighting process if the temperature at the wall control is less than the set temperature on the dial.

The PF100 is more than just an automatic ignition pellet furnace. The automatic system will allow the fire size to be adjusted to match the heating needs and even put the fire out if necessary. If heat is needed after the fire is out, the PF100 will automatically re-ignite and adjust the fire size to match the heating need.



This is the Control setting that will allow the Wall Control to function.

10. **Fill hopper** with pellets and **remove ashes** as required.

Type of Fuel

Use pelletized wood only. **Note:** The lower the ash content of the pellets the less cleaning that will be needed of the heat exchanger surfaces. The cleaner these surfaces are kept, the more efficient the furnace will be. **NOTE: Do not burn garbage, gasoline, naphtha, engine oil, or other inappropriate materials in the PF100.**

Store pellets in the manufacturer’s wrapping until needed to prevent pellets from absorbing moisture. Do not store fuel within the appliance installation clearances, or within the space required for fueling, ash removal, and other routine maintenance operations.

AUTO-LIGHT

MANUAL-LIGHT

Fig. 55

Lighting A Fire Manually

Lighting the fire manually will not be necessary unless the igniter in the burnpot fails.

Follow steps 1 through 5 of the instructions for automatic lighting.

6. Flip the Igniter Switch Down into the "MANUAL-LIGHT" position. See Fig. 55.

7. Open inner and outer ash doors as shown in figs. 63, 64, 65, on page 30.

8. Fill burnpot with pellets as shown. See Fig. 57. Only fill level with the front edge. (----- DO NOT OVERFILL -----)

9. Have matches or other ignition source ready.

10. Apply starting gel as shown in Fig. 58.

NOTE: Stirring the starting gel into the pellets usually allows the fire to become established quicker.

CAUTION: A vapor flash could occur if too much time is allowed to pass before lighting the starting gel.

CAUTION: Care must be taken not to get starting gel on your hands or clothing. Serious burns could occur during the lighting process.

CAUTION: Never try to apply more starting gel to an already burning fire, or a fire with smoldering pellets.

"NEVER USE GASOLINE, GASOLINE-TYPE LANTERN FUEL, KEROSENE, CHARCOAL LIGHTER FLUID, OR SIMILAR LIQUIDS TO START OR "FRESHEN UP" A FIRE IN THIS FURNACE. KEEP ALL SUCH LIQUIDS WELL AWAY FROM THE FURNACE WHILE IN USE".

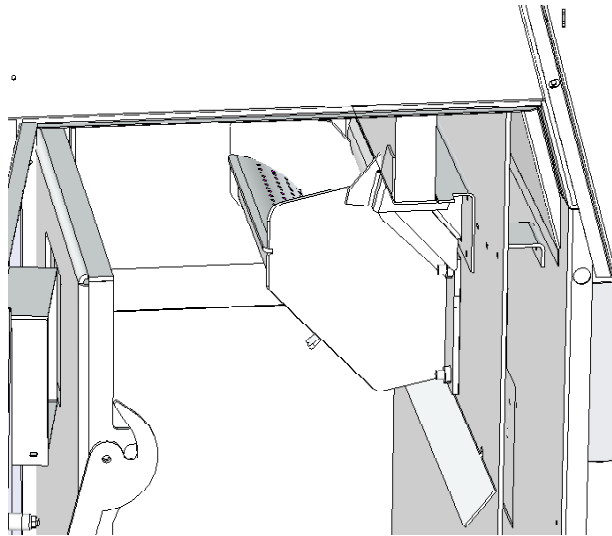

Fig. 56

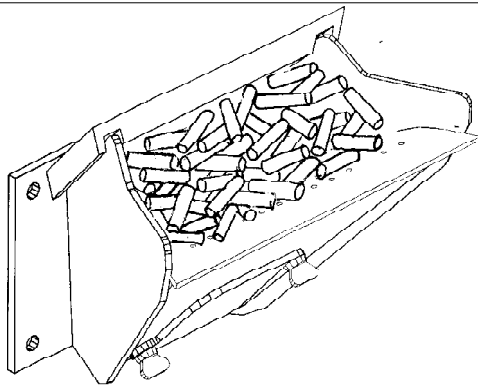

Fig. 57

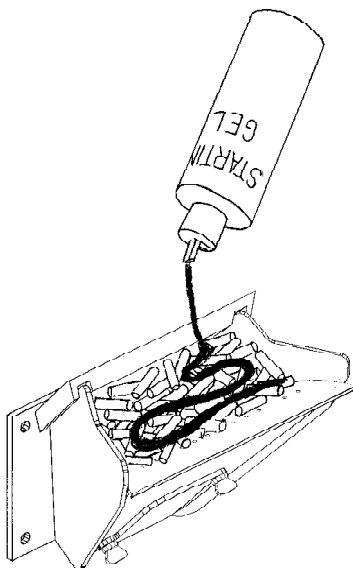

Fig. 58

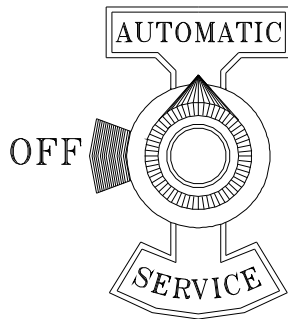

Fig. 59

11. Turn Mode Selector to “SERVICE”

This will start the combustion blower and allow the ESP to control the fire in relation to the Temp Dial setting 1 through 7. Once the fire is well established the Temp Dial can remain on any number setting desired, or changed to the “AUTOMATIC” setting. If you change to “AUTOMATIC” remember to set the Temp Dial to “Normal Setting” for proper Wall Control calibration.

NOTE: When the Switch is set to Manual-Lite in the “AUTOMATIC” mode, the Wall Control will function as in Auto-Lite except the fire will not be allowed to go out. It will only be allowed to go to a minimum burn rate between the times the Wall Control is calling for heat. This rate is about 1 pound of fuel per hour.

12. Light The Starting Gel With A Match.

13. Close The Doors

The fire will light and the PF100 will adjust the fire to proper level according to the temperature dial setting on the wall control.

14. Return air filter

Check the condition of the return air filter periodically and replace as needed.

Solid-fuel burning appliances need to be cleaned frequently because soot, creosote, and ash may accumulate. If you suspect a chimney/vent pipe fire 1) Call the fire department. 2) Remove fuel from the burn pot using the burnpot scraping tool to scrape the pellets into the ash pan. 3) Remove the ash pan from the unit and take outside. Do not place ash pan on a combustible material. 4) Turn off circuit breaker at unit. 5) Do not use the unit until a qualified person has inspected your appliance and venting.

Burnpot cleaning:

The burnpot should be cleaned no less than once a week. For best operation the burnpot should be cleaned every time the hopper is filled with pellets. The fire does not have to be out to scrape the burnpot although it is recommended the furnace be on minimum burn at the time of cleaning.

Note: The furnace can easily be turned to minimum burn regardless of present operation. Simply turn the Mode Selector to SERVICE. Then turn the Temp Dial to the #1 setting. If this is done before starting to refill the hopper the furnace will not be as hot when scraping the burnpot. When the burnpot cleaning is completed don't forget to turn the control back to the Wall Control positions. See Fig. 61.

Use the flat end of the scraper provided to scrape down over the holed surface of the burnpot grate. See Fig. 62. It is not necessary to clean out the scrapings from this cleaning because they will be pushed out the next time the auger operates.

Note: Make a special effort to scrape the bottom inside corners of the burnpot where the auger tube enters the burnpot. Carbon deposits can build up over time in this area that may cause a restriction to the flow of pellets into the burnpot.

Note: An old long shank screwdriver with the end sharpened is an ideal aid in the removal of these deposits.

Cleaning the burnpot air chamber:

This area only needs to be cleaned twice a heating season, unless excessive buildup is noticed during scheduled cleanings.

There is a cover on the front of the burnpot to gain access to the air chamber and igniter. The cover is held into place by two thumb screws. Loosen the thumb screws and remove the cover. See Fig. 60. The air chamber can be cleaned of any ash that has fallen through the holes during operation and cleaning. Also at this time, remove the feeder assembly cover and remove any fines that may have accumulated.

NOTE: ALWAYS REMEMBER TO CLOSE THE CLEANOUT COVER AFTER CLEANING.

Feeder Chamber (Fig. 61):

This chamber may get a buildup of fines from the feeder mechanism movement. This area should be checked and cleaned at least once a year.

To remove the feeder cover:

- Remove the 5/16" wing nut.
- Slide the cover off of the threaded stud.
- Inspect and clean the inner chamber if necessary. See Fig. 61.
- Reinstall the cover making certain it is centered on the feeder body and tighten as tightly as you can by hand.

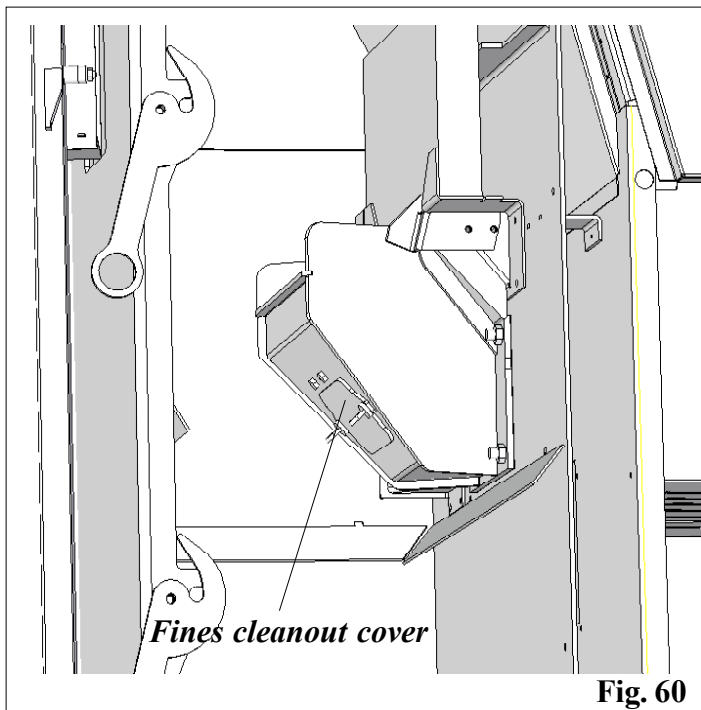
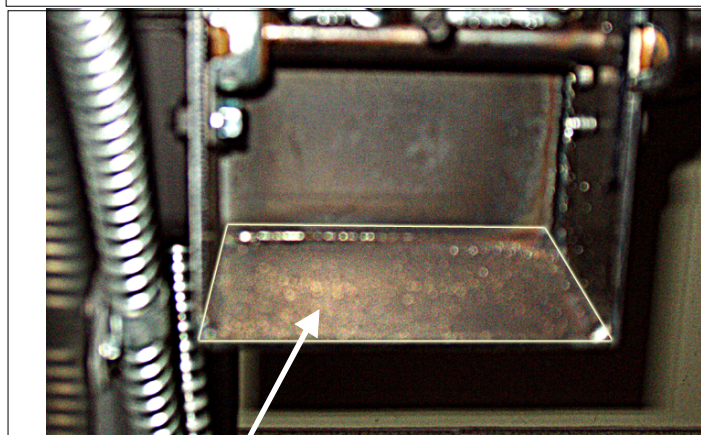

Fig. 60



Possible pellet fines build up area.

Fig. 61

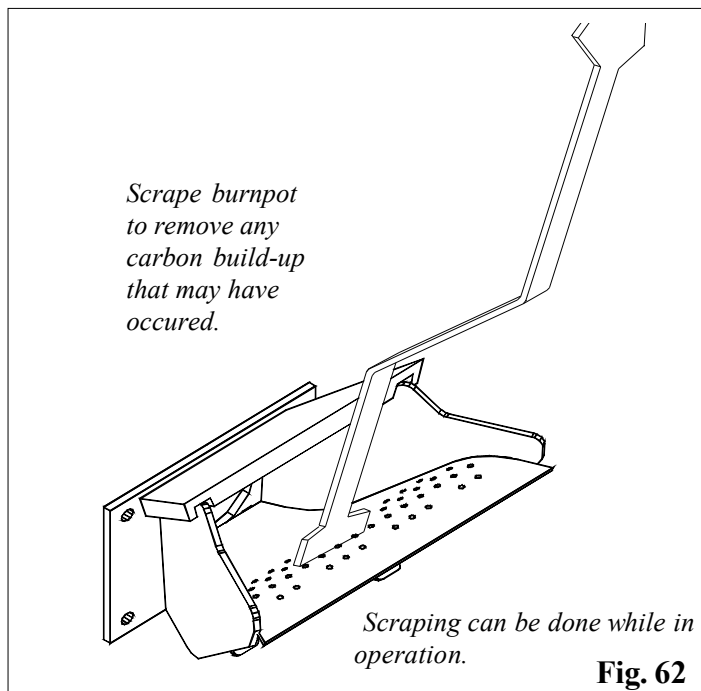

Fig. 62

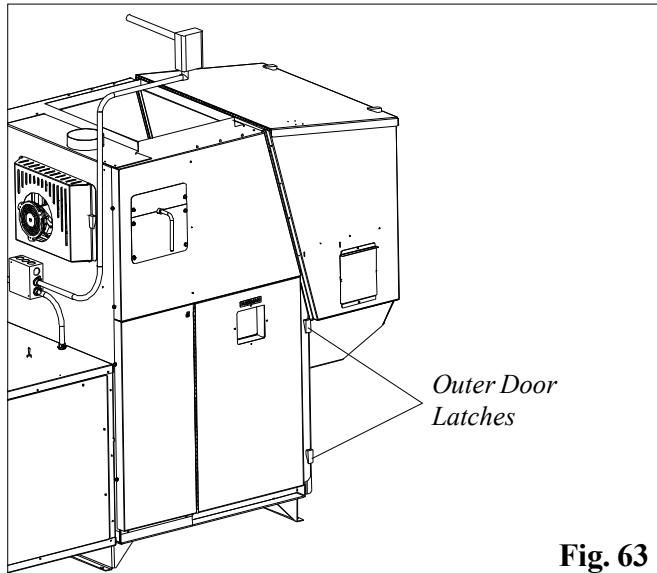

Fig. 63

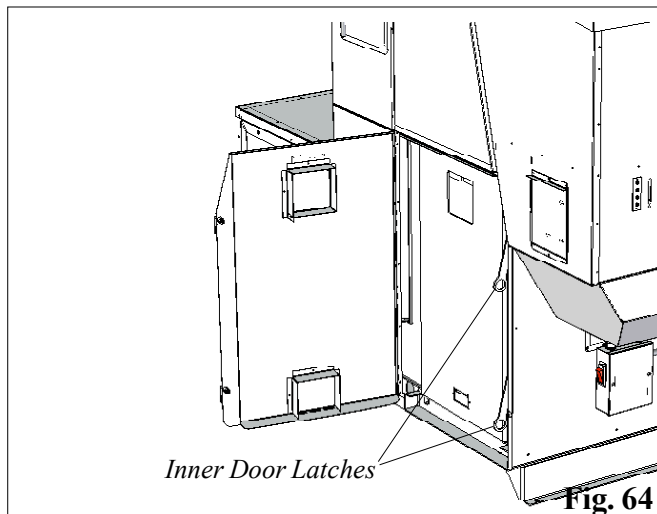

Fig. 64

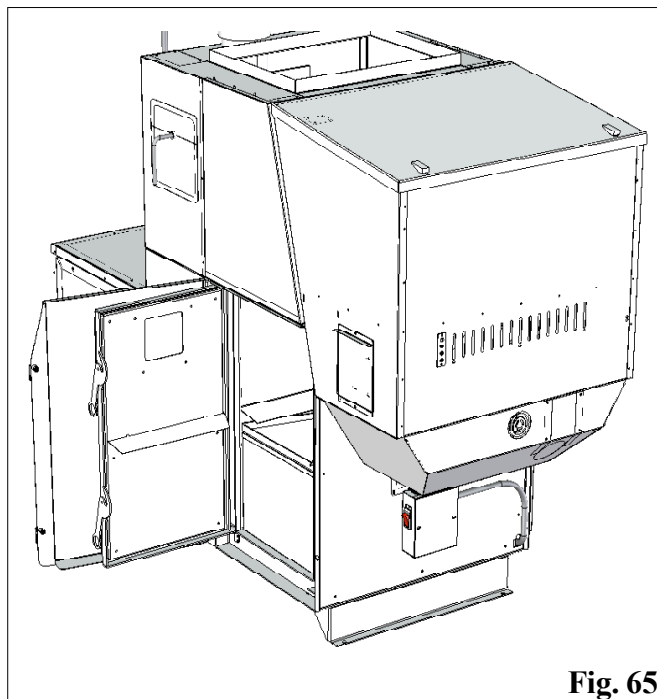

Fig. 65

Ash Removal

It is recommended to remove the ashes when the furnace is not in operation. This lessens the chances of coming in contact with hot surfaces. Ashes can be removed while in operation but, extra care must be taken.

Open Outer Ash Door

Lift the two latches shown in figure 63 and open the outer door as shown in figure 64. If the Distribution Blower is running when the outer door is open, some air will escape around the door opening. This is not a problem, however any dust that is caused in the ash removal process can potentially be blown around.

Open Inner Ash Door

Lift latches shown in figure 64 and open the inner door as shown in figure 65.

NOTE: Keep hopper lid and ash pan doors closed during operation and maintain all seals in good condition.

Remove Ash Pan

Always wear gloves to remove ash pan. Grab the ash pan by the handle and pull it out of the furnace. Lift the handle and use it for carrying the ash pan. **Close the inner door before disposing of the ashes.**

Disposal of Ashes

Ashes should be placed in a metal container with a tight fitting lid. The closed container of ashes should be placed on a non-combustible floor or on the ground, well away from all combustible materials, pending final disposal. If ashes are disposed of by burial in soil or otherwise locally dispersed, they should be retained in the closed container until all cinders have thoroughly cooled.

Soot and Flyash: Formation and Need for Removal

The products of combustion will contain small particles of flyash. The flyash will collect in the exhaust venting system and restrict the flow of the flue gases. Incomplete combustion, such as occurs during startup, shutdown, or incorrect operation of the room heater will lead to some soot formation which will collect in the exhaust venting system. The exhaust venting system should be inspected at least twice monthly to determine if cleaning is necessary.

Cleaning the accordion heat exchanger/firebox:

This cleaning should be done after each ton of pellets used. The frequency of this cleaning will be directly related to the quality and the ash content of the pellets being used. Keep in mind that the cleaner the heat exchanger surface is kept, the higher the heat transfer efficiency will be.

Due to its ease of restarting it is recommended that the furnace be **OFF** and **COOL** before cleaning.

Before starting to clean the inside of the firebox area it is recommended that all of the baffling be removed. Start with the upper heat exchanger baffle. See Fig. 66. Push straight upward on the lower ash slide angle approx. 1/2". This will release the baffle from the positioning brackets and allow it to be tilted toward the burnpot and removed from the furnace.

Note: Observe the positioning tabs and bracket system on the rear of the upper baffle as it is being removed, for easier replacement later.

Remove the lower baffle plate. This baffle is a flat plate that sits on the furnace floor. Tip the top edge toward the burnpot and lift up and out of the furnace. Note how the baffle bottom edge sits behind the ash pan guide and against the heat exchanger. See Fig. 67.

With all of the baffling removed, the entire firebox area and the accordion heat exchanger can be cleaned. Use the pointed end of the scraper supplied to clean the accordion heat exchanger. A small wisp brush, wire brush, or an old stiff bristled paint brush works best for cleaning the firebox walls. All of the fly ash removed during cleaning will fall to the bottom of the furnace where there is an unobstructed access for cleaning. Even the bottom ends of the chains can be seen and accessed easily from the door opening. See Fig. 68.

CAUTION: Cleanout of the heat exchanger, flue pipe, chimney, and combustion blower fan housing, is especially important at the end of the heating season to minimize corrosion during the summer months, caused by accumulated ash.

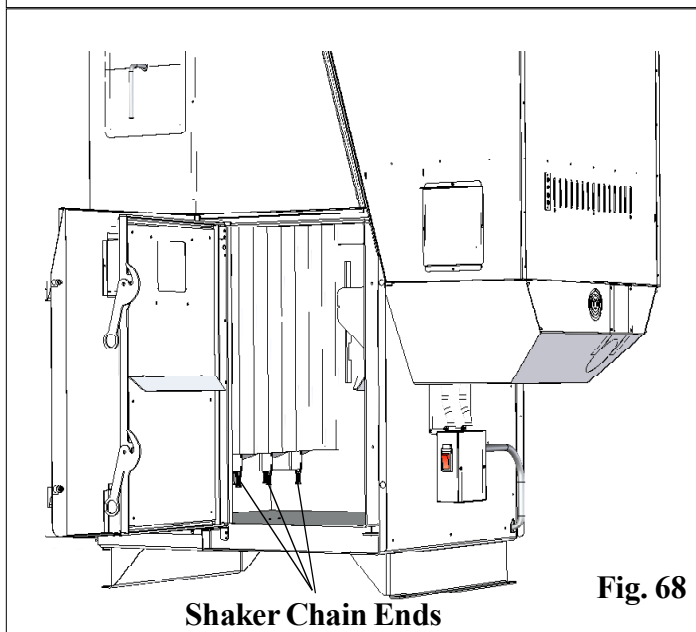
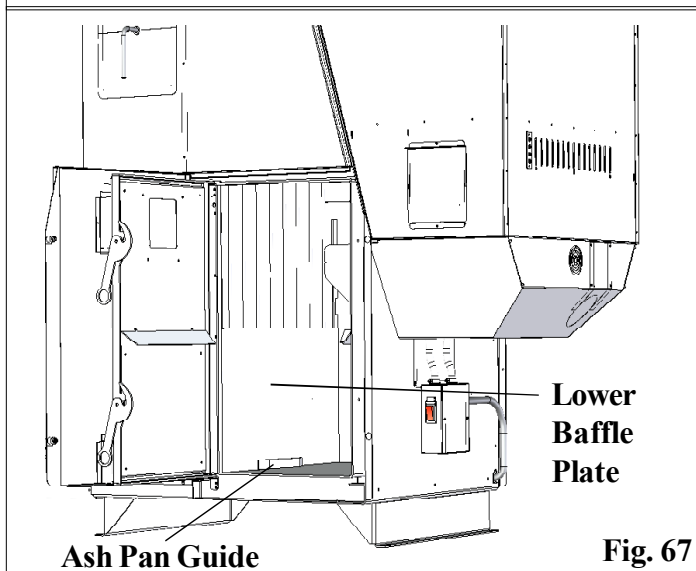
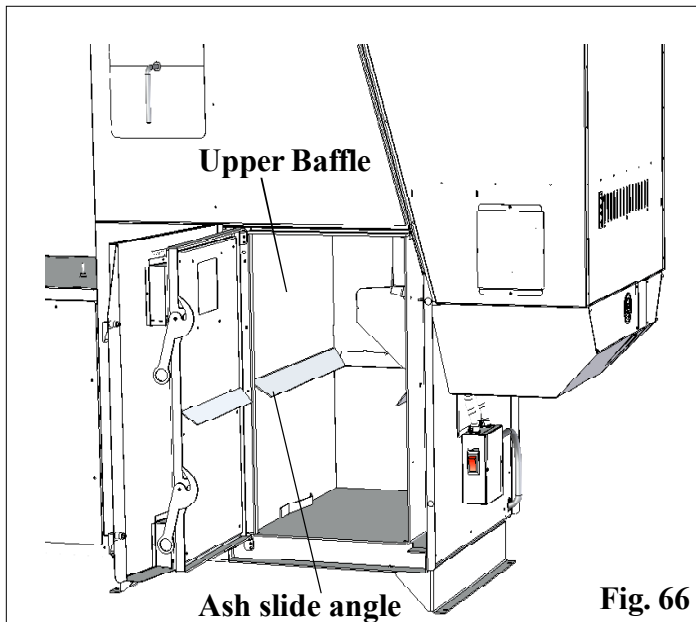

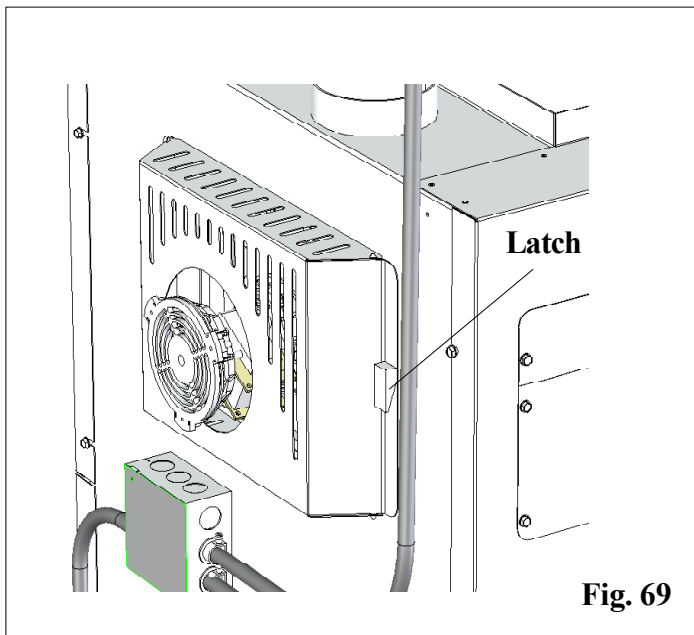

Combustion Blower Cleaning

Remove the combustion blower heat shield. There are two latches that hold the shield in place. See Fig. 69. Flip the latches up and pull the shield away from the furnace. It can not be fully removed, it can only be moved down over the wire until it hangs on the junction box.

The furnace **MUST be OFF and COOL** before you should attempt to clean the combustion blower.

The wire to the combustion blower doesn't need to be disconnected during the cleaning process.

Loosen the three (3) thumb screws about 4 turns each. See Fig. 70. Hold the motor head with one hand and the blower plate handle with the other hand. Pull outward on the plate handle until the complete unit comes loose. Now rotate the plate counter-clockwise about 1/8 turn. This will allow the complete assembly to be removed from the blower chamber.

Clean the blower fan blades and the blower plate sealing overlap. See Fig. 71.

Note: Be carefull not to bend the fan blades, this will throw the fan blade out of balance or it may rub the inner chamber, which may affect the performance of the furnace. Any horizontal and vertical flue pipe directly above the unit should be cleaned at this time.

Note: The horizontal flue pipe directly above the furnace is the first place fly ash will settle, due to the slowing of flue gas velocity through horizontal pipe. Cleaning of horizontal venting pipes is very important to the efficiency of this furnace.

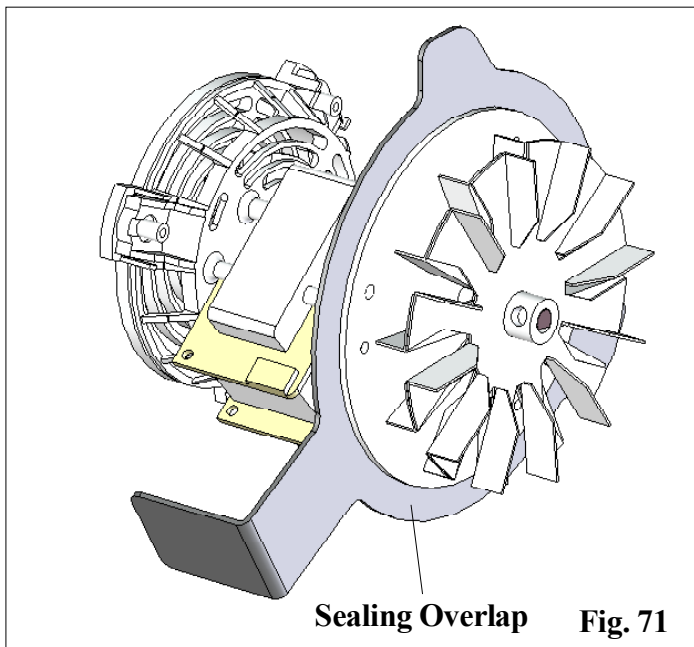
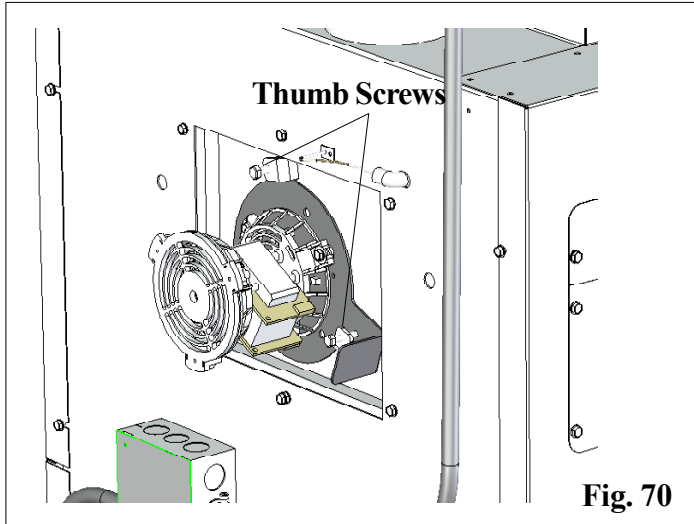

Maintenance

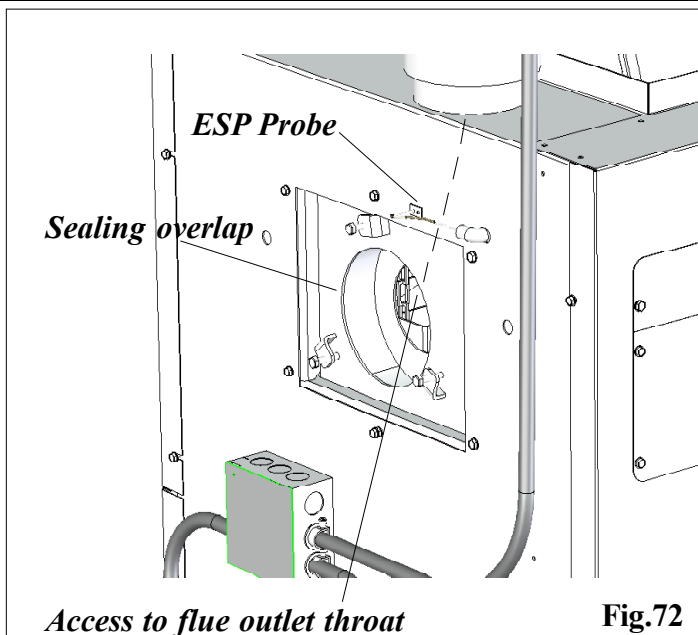

Clean the flue outlet throat (this is the hole that goes up into the flue pipe). See Fig. 72.

Note: The ESP probe sensing tip extends into this same area. **CARE MUST BE TAKEN NOT TO DAMAGE THE ESP PROBE DURING CLEANING.** Bending of the ESP probe will make it difficult to remove if it should become necessary. See Fig. 72.

Clean the inner chamber of the blower. See Fig 72.

Clean the furnace blower plate, sealing overlap. See Fig 72. Inspect the tops of the heat exchanger tubes where the chain shaker mechanism is located. Make sure there are no fly ash buildups that may block the easy flow of flue gasses into the combustion blower inlet hole. (A flashlight may be necessary.)

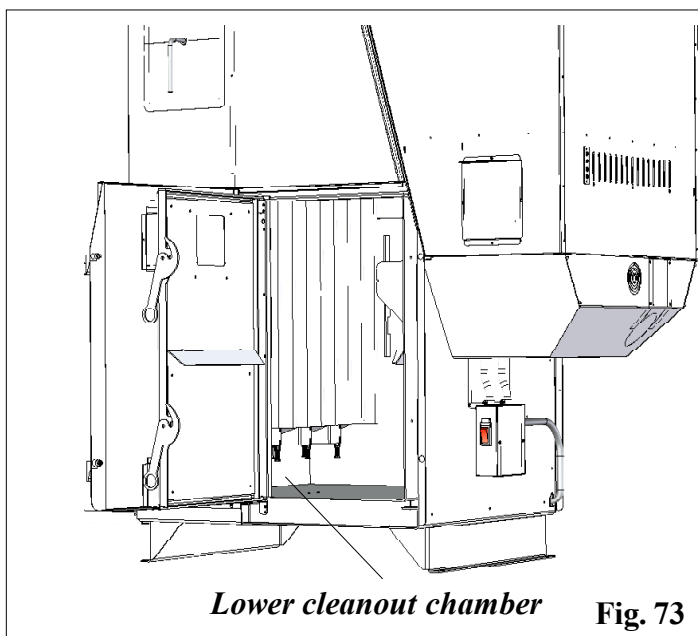

Inspect the chain shaker mechanism for proper operation.

Note: Fly ash can build up to the top edges of the heat exchanger tubes without affecting operation. The chain shaker will cause any excess to fall down into the chamber under the tubes where it can be cleaned out through the fire box. See Fig. 73.

CAUTION: Inspect flue pipes, flue pipe joints and flue pipe seals regularly to ensure that smoke and flue gases are not drawn into, and circulated by, the air-circulation system.

Cleaning the Tube heat exchangers:

The heat exchangers tubes have an external handle that operates the cleaning mechanism. See Fig. 74.

This cleaning should be done at least once a week, although it can be done as often as desired. The cleaner the heat exchangers are, the more efficient the furnace will be. This cleaning can be done at any time and in any mode of operation.

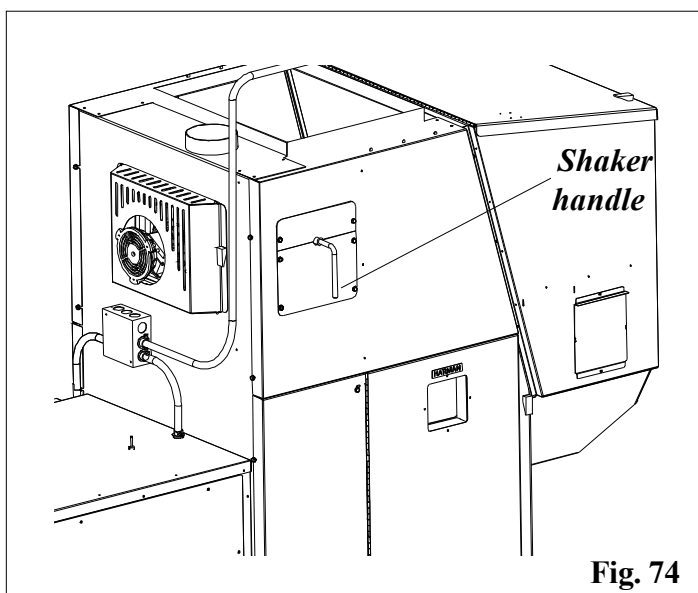

The handle has two directions of movement, Right to Left and In and Out. All inside surfaces of these rectangular tubes can be cleaned with this range of motion. First, with the handle pushed in, turn the handle right to left, the full sweep, several strokes. Second, with the handle pointing straight down, pull out and push inward several strokes. Third, with the handle all the way out, turn the handle right to left, the full sweep, several times. End with the handle pushed inward and pointing down.

FEEDER DOES NOT FEED

1. No pellets in hopper.
2. Firebox draft may be too low for low draft pressure switch in feeder circuit to operate. **Check for closed doors**, loose or missing gasket on doors or hopper lid, or a faulty pressure switch.
3. Feed motor will not run until ESP senses 165 deg. F. Maybe you did not put enough pellets in the burn pot before lighting the fire manually.
4. Something is restricting flow in the hopper or causing the slide plate to stick.
5. Feed motor has failed.

PARTIALLY BURNED PELLETS

1. Feed rate too high.
2. Draft too low. (Check burn pot clean-out slide and door gasket).
3. Burn pot or heat exchanger tubes may need to be cleaned.
4. Combination of all the above.
5. #6 status blink: A 6 blink control board status indication is caused by poor or incomplete combustion. The Automatic Ignition circuit board has the ability to track the combustion through feed settings and ESP temperatures. When the control board has calculated poor or incomplete combustion, it will shut down the unit as a safety feature. (Poor or incomplete combustion is a contributor of creosote which may cause a chimney fire)
A 6 blink status may be caused by several things:
 1. Blocked or partially blocked flue.
 2. Blocked or partially blocked inlet air.
 - a. Backdraft damper on the inlet pipe may be stuck closed.
 - b. If outside air is installed, the inlet cover may be blocked.
 3. The air chamber under the burnpot may be filled with fines and small bits of ash.
 4. The holes in the burnpot may be getting filled with ash or carbon buildup.
 5. Combustion blower fan blades may need cleaned.
 6. There is no fuel in the hopper.

SMOKE SMELL

Seal the vent pipe joints and connection to stove with silicone.

FIRE HAS GONE OUT

1. No pellets in hopper.
2. Draft setting is too low.
3. Something is restricting fuel flow.
4. Feed motor or combustion blower has failed.
5. Power failure or blown fuse.

SMOKE IS VISIBLE COMING OUT OF VENT

1. Air-fuel ratio is too rich.
 - A. Feed rate too high.
 - B. Draft too low caused by a gasket leak.

LOW HEAT OUTPUT

1. Feed rate too low
2. Draft too low because of gasket leak.
3. Poor quality or damp pellets
4. Combination of 1 and 2.

Helpful Hints

Cleaning Burn Pot

Whenever your stove is not burning, take the opportunity to scrape the burn pot to remove carbon buildup. A vacuum cleaner is handy to remove the residue. **Be sure the stove is cold if you use a vacuum.**

Carbon buildup can be scraped loose with the fire burning using the special tool provided with your stove. Scrape the floor and sides of the burn pot. The carbon will be pushed out by the incoming fuel. Always wear gloves to do this.

Removing Ashes

Turn the Temp Dial to number 1 approximately 30 minutes before removing ashes. This will result in a cooler stove and ash pan.

Maximum Feed Adjuster settings are not needed in most cases. Operating in the normal range (#4) is recommended when maximum heat output is not required. The ESP probe prevents the stove from being over-fired.

Keep the stove free of dust and dirt.

Fuel

Pellet fuels are put into 3 categories in terms of ash content. Premium at 1% or less, Standard at 3% or less and all others at 3% or more.

The P68 is capable of burning all 3 categories of pellets due to a patented feeder and burn pot system.

It should be noted, however, that higher ash content will require more frequent ash removal, scraping of the burn pot, and may provide less BTU's per pound. Normally, standard and high ash pellets cost less than premium pellets and can be cost effective when burned in the P68.

The moisture content must not exceed 8%. Higher moisture will rob BTU's and may not burn properly.

Feeder Parts

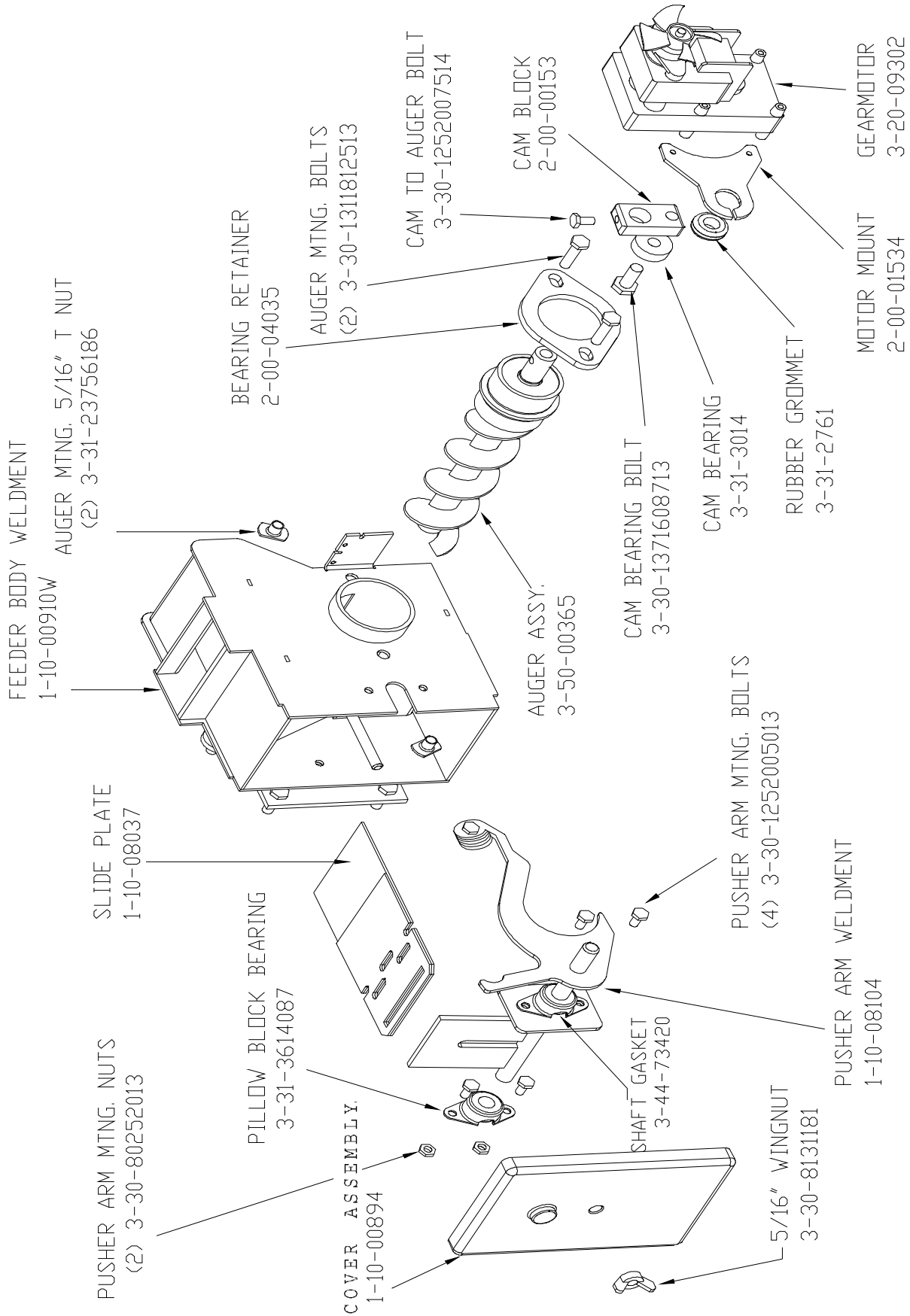

Specifications

BTU Input Range 0 - 8500 to 112,000

0 if system is satisfied, then
 min. burn = 1 pound per hour
 max. burn = 13 pounds per hour

Electrical 120 VAC 60 Hz.

combustion blower 1.4 AMP
 auger motor .7 AMP
 ignitor element 2.3 AMP
 control board .05 AMP
 aux. auger (optional) .7 AMP
 1000 CFM blower (shade pole) 6.5 AMP
 1500 CFM blower (PSC) 4 AMP
 2000 CFM blower (PSC) 5.1 AMP

Average electrical usage is .5 KWH

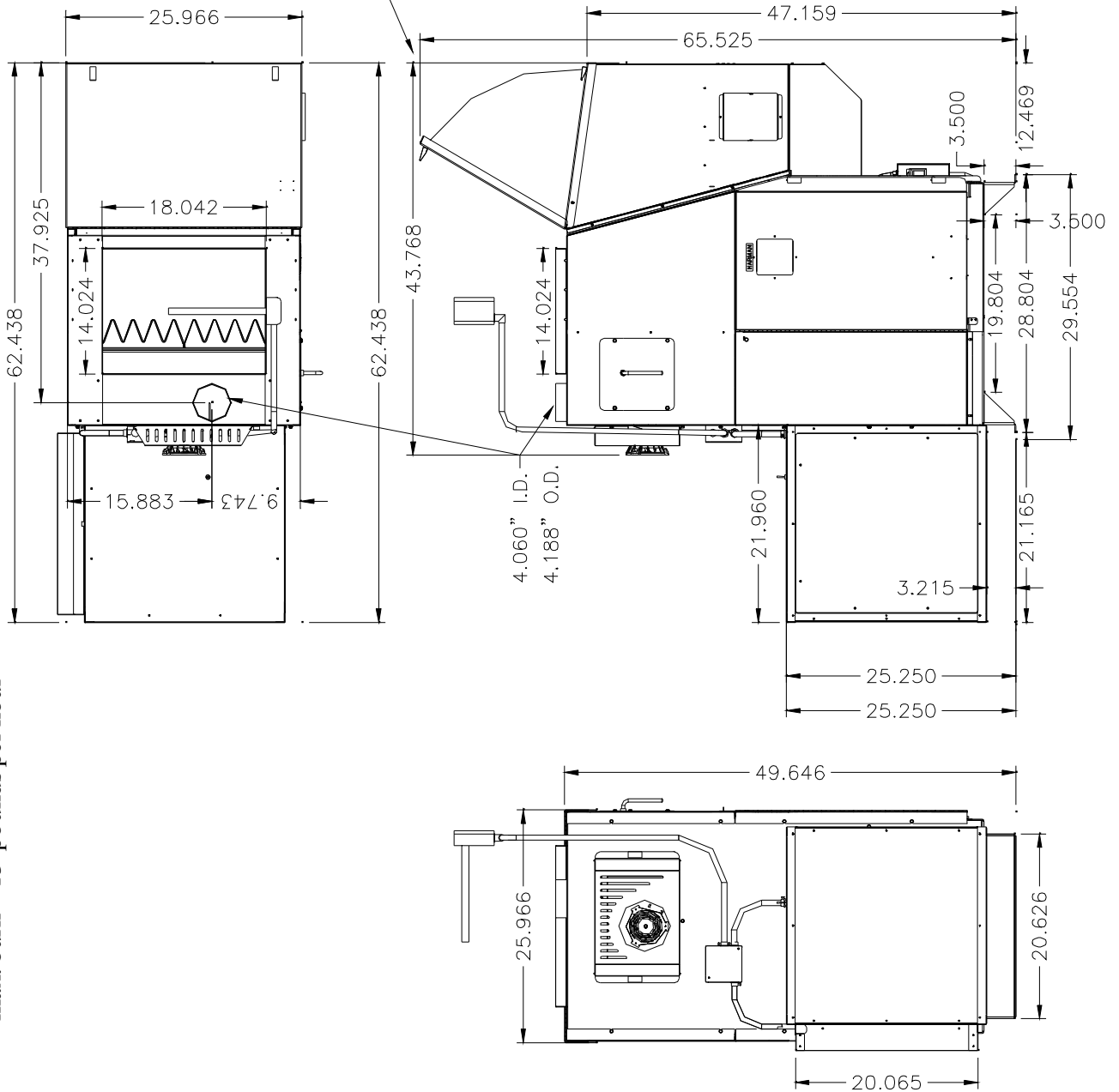

Wiring Diagram

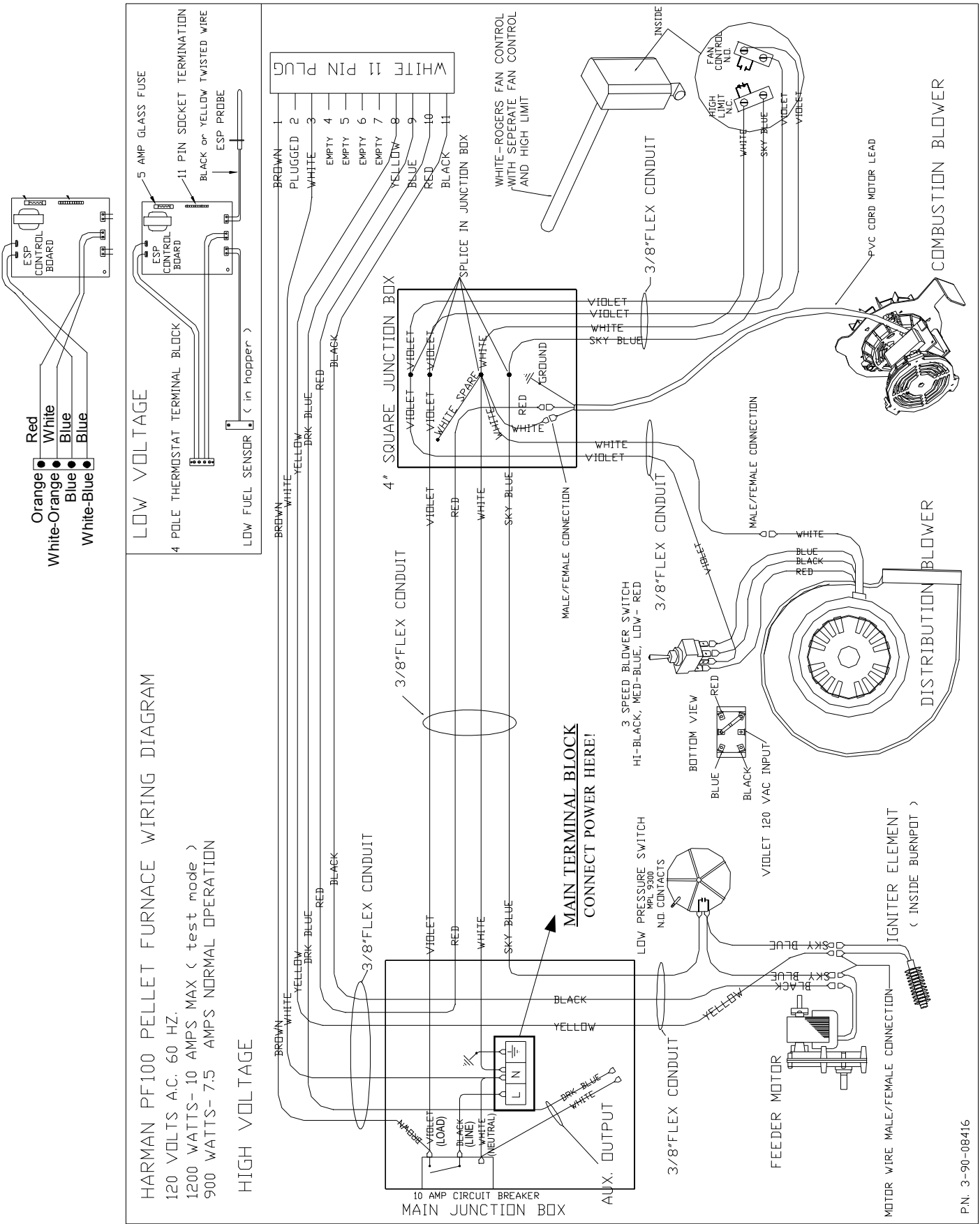

HARMAN PF100 PELLET FURNACE WIRING DIAGRAM
 120 VOLTS AC, 60 HZ.
 1200 WATTS-10 AMPS MAX (test mode)
 900 WATTS-7.5 AMPS NORMAL OPERATION

P.N. 3-90-08416

Parts List

Rubber Grommet (7.5') Hopper lid gasket	0-88-00248
Igniter Element Assembly	1-10-06620
Burn Pot Weldment	1-10-73403
Exchanger Baffle-Top	2-00-73418
Exchanger Baffle-Bottom	2-00-73314
Arrow Scraper	2-00-773850
Flame Guide	3-00-08534
Flame Guide Insulator	3-44-35263
Thermister Probe	3-20-00744
Thermostat	3-20-08101
Circuit Board G4941	3-20-03100
Differential Switch	3-20-9301
5" Single Fan Blade (standard)	3-20-40985
1000 CFM Distribution Blower Motor	3-20-36648
1000 CFM Distribution Blower Complete	1-10-01007
Black Control Knobs (2)	3-31-00534
White/Black Control Knob	3-31-00968
Control Knob Shaft	3-31-00982
12 X 6 X 1.25 Firebrick	3-40-86125
Glass With Gasket	1-10-5555
Ash Pan	1-10-73351
Burn Pot Gasket	3-44-00409
Wiring Diagram	3-90-73370
Owners Manual	3-90-08101
Hopper Lid Label	3-90-08415
Chain Shaker Gasket	3-44-08100
Low Fuel Sensor	4-20-03835
Combustion Blower	3-21-08639
Inner Ash Door Gasket	2-00-00539
Circuit Breaker Harness	3-20-04947
10 Amp Circuit Breaker	3-20-334110
4 Pole Thermostat Extension	3-20-04946
3 Speed Switch	3-20-70020
20 X 20 X 1 Air filter	3-40-20201
3 Position Terminal Block	3-20-03018
Junction Box Harness	3-20-04948
Fan Limit	3-20-23139
2 Pair Twisted Cat 3 Cable (100')	3-20-02583
Options:	
5" Double Fan Blade (high altitude)	3-20-502221
1500 CFM Blower	1-00-00682
2000 CFM Blower	3-21-52092
Outside Air Assembly	1-10-09542
12-1/2' Flex Pipe 2-3/4" ID	2-00-08544
25' Flex Pipe 2-3/4" ID	2-00-08545

HARMAN CENTRAL HEAT WARRANTY **5 YEAR LIMITED WARRANTY (Residential)** **1 YEAR LIMITED WARRANTY (Commercial)**



Harman Stove Company warrants its central heat products to be free from defects in material or workmanship, in normal use and service, for a period of 5 years from the date of sales invoice and for mechanical and electrical failures, in normal use and service, for a period of 1 year from the date of sales invoice.

If defective in material or workmanship, during the warranty period, Harman Stove Company will, at its option, repair or replace the product as described below.

The warranty above constitutes the entire warranty with respect to Harman Stove Company. HARMAN STOVE COMPANY MAKES NO OTHER WARRANTY, EXPRESSED OR IMPLIED, INCLUDING "ANY" WARRANTY OF MERCHANTABILITY, OR WARRANTY OF FITNESS FOR A PARTICULAR PURPOSE. No employee, agent, dealer, or other person is authorized to give any warranty on behalf of Harman Stove Company. This warranty does not apply if the product has been altered in any way after leaving the factory. Harman Stove Company and its agents assume no liability for "resultant damages of any kind" arising from the use of its products. In addition, the manufacturer and its warranty administrator shall be held free and harmless from liability from damage to property related to the operation, proper or improper, of the equipment.

THERE ARE NO WARRANTIES, WHICH EXTEND BEYOND THE DESCRIPTION ON THE FACE HEREOF.

THESE WARRANTIES APPLY only if the device is installed and operated as recommended in the operators manual.

THESE WARRANTIES WILL NOT APPLY if abuse, accident, improper installation, negligence, or use beyond rated capacity causes damage.

HOW TO MAKE A CLAIM - any claim under this warranty should be made to the dealer from whom this appliance was purchased. Then contact is made with manufacturer, giving the model and serial numbers, the date of purchase, your dealer's name and address, plus a simple explanation of the nature of the defect. Extra costs such as labor, mileage and overtime are not covered. Nuisance calls are not covered by these warranties.

THIS WARRANTY IS LIMITED TO DEFECTIVE PARTS, REPAIR AND/OR REPLACEMENT AT HARMAN STOVE COMPANY'S OPTION AND EXCLUDES ANY INCIDENTAL AND CONSEQUENTIAL DAMAGES CONNECTED THEREWITH.

WARRANTY EXCLUSIONS: Failure due, but not limited to, fire, lightning, acts of god, power failures and/or surges, rust, corrosion and venting problems are not covered. Damage and/or repairs including but not limited to; filters, fuses, knobs, glass, door packing, paint, batteries or battery backup and related duct work are not covered. Also excluded from this warranty are consumable or normal wear items including but not limited to; grates, fire brick, gaskets. Additional or unusual utility bills incurred due to any malfunction or defect in equipment and the labor cost of gaining access to or removal of a unit that requires special tools or equipment are not covered. Maintenance needed to keep the stove in "good operating condition" is not covered. This includes, but is not limited to, cleaning, adjustment of customer controls and customer education. Labor, material, expenses and/or equipment needed to comply with law and/or regulations set forth by any governmental agencies are not covered.

This warranty provides specific legal rights and the consumer may have other rights that vary from state to state.

PLEASE READ LITERATURE BY THE MANUFACTURER FOR THE VARIOUS ACCESSORY DEVICES. THE MANUFACTURER WARRANTS THESE ACCESSORY DEVICES, NOT HARMAN STOVE COMPANY OR THEIR WARRANTY ADMINISTRATOR. FURTHERMORE, THESE ACCESSORY DEVICES MUST BE INSTALLED AND USED ACCORDING TO THE RECOMMENDATIONS OF THE MANUFACTURER.

Remedies - The remedies set forth herein are exclusive and the liability of seller with respect to any contract or sale or anything done in connection therewith, whether in contract, in tort, under any warranty, or otherwise, shall not, except as herein expressly provided, exceed the price of the equipment or part of which such liability is based.

CLARIFY - The above represents the complete warranty, which is given in connection with central heat, manufactured by Harman Stove Company. No other commitments, verbal or otherwise, shall apply except by a written addendum to this warranty.

Testing Label



Tested and Listed By **Beaverton Oregon USA**

Harman PF-100

LISTED PELLET FUEL CENTRAL OR SUPPLEMENTARY FURNACES FOR RESIDENTIAL USE/
APPAREIL DE CHAUFFAGE CENTRAL OU SUPPLEMENTAIRE ENREGISTRÉ DE BOULETTES
COMBUSTIBLES POUR USAGE DANS LES RÉSIDENCES



OMNI-Test Laboratories, Inc.
Report #/Rapport #135-S-02-2
Certified for U.S.A. and Canada
Certifié pour les États-Unis et le Canada

Serial No./
Numéro de Série

Tested June 2001 to CAN/CSA B366.1-M91, UL 391, ASTM E 1509-95 & ULC C1482-M1990.

Testé en Juin 2001 à CAN/CSA B366.1-M91, UL 391, ASTM E 1509-95 & ULC C1482-M1990.

Install and use only in accordance with the manufacturer's installation/operating instructions. Refer to authorities having jurisdiction for proper installation. Contact local building or fire officials about restrictions and installation inspection in your area. If there are no applicable local codes, follow ANSI/NFPA 211 and CAN/CSA B365. Special precautions are required for passing the chimney through a combustible wall or ceiling.

Installez et utilisez en accord avec les instructions d'installation et d'opération du fabricant. Référez-vous à des professionnels avec autorité dans l'installation. Contactez le bureau de la construction ou le bureau des incendies au sujet des restrictions et de l'inspection d'installation dans votre voisinage.

Inspect and clean exhaust venting system frequently in accordance with manufacturer's instructions. Use a 4" diameter type "L" or "PL" venting system.

S'il n'y a pas de codes locaux, suivez alors ANSI/NFPA211 et CAN/CSA B365. Prenez des précautions spéciales lorsque vous faites passer une cheminée à travers un mur ou un plafond combustible. Inspectez et nettoyez le système de ventilation fréquemment en accord avec les instructions du fabricant. Utilisez un système de ventilation de 4" de diamètre de type "L" ou "PL"

A Harman PF 100 may be connected to an existing furnace or heat pump duct system.

Le Harman PF100 peut être connecté à une fournaise ou un système de pompe de chauffage déjà existants.

Modèle Modèle	Fuel Combustible	Chimney Connector Size Grandeur du Tuyau de Cheminée	BTUH/Kw Input Pellet Rendement des Boulettes BTUH/Kw	Electrical Rating Classification Electrique	Maximum Overcurrent Protection Protection Maximum du Courant
PF 100	Pellet Boulettes	4"	112,625 BTUH (33 Kw)	120V, 9.3A, 60 Hz	20 AMP

Clearances to Combustibles/Espaces Libres aux Combustibles

Combustibles to Filter Box on Appliance	1" (25 mm)	Des combustibles à la boîte de filtration de l'appareil
Combustibles to Connector Pipe	*2" (51 mm)	Des combustibles au tuyau connecteur
Combustibles to Appliance	12" (305 mm)	Des combustibles à l'appareil
Supply Air Plenum to Ceiling	4" (102 mm)	Provision d'air plénum au plafond
Supply Air Plenum to Combustible Chase	1" (25 mm)	Provision d'air plénum au châssis du combustible
Appliance Body to Ceiling	28" (711 mm)	De l'appareil au plafond
Combustibles from Stove Front	36" (914 mm)	Des combustibles au devant du poêle

* At 16" of pipe length distance from flue collar while maintaining listed clearances from appliance body.
Un tuyau de grandeur de distance de 16" de l'ouverture du ventilateur doit être en accord avec l'espace libre mentionné de l'appareil même.

Essential parts and subassemblies provided for field assembly are as follows / Pièces essentielles et sous-ensembles procurées pour l'assemblage sont les suivantes:

Thermostat/Thermostat	Burnpot Scraper/Grattoir de la chaudière de chauffage
Datacom Wire/Fil datacom	1000 CFM Blower (Standard)/Ventilateur CFM 1000 (Standard)
Fan Control High Limit/Contrôle du ventilateur haute limite	1400 CFM Blower (Optional)/Ventilateur CFM 1400 (Optionnel)
Fire Brick/Brique de feu	Return Air Filter Box/Boîte de filtration pour retour d'air
Heat Exchanger Baffles/Défecteurs d'échange de chaleur	Ash Pan/Bassin des cendres

DO NOT CONNECT THIS UNIT TO A CHIMNEY FLUE SERVING ANOTHER APPLIANCE

NE PAS CONNECTER CET APPAREIL À UN TUYAU DE CHEMINÉE SERVANT UN AUTRE APPAREIL

WARNING! Do not operate with fire chamber or ash removal doors open. Do not store fuel or other combustible material within installation clearance area.

ATTENTION! Ne pas opérer si la porte du combustible ou la porte de la cuvette des cendres sont ouvertes. Ne pas placer le combustible et les matières combustibles à l'intérieur de l'espace désignée pour l'installation.

CAUTION! Hot while in operation.

DO NOT touch. Keep children, clothing, furniture and other combustible material out of the installation clearance area.

DO NOT connect this unit to a chimney flue that serves another appliance.

Flooring must be a non-combustible material covering the installation clearance area, and 18" in front of, and 8" to either side of the fuel loading doors.

ATTENTION! Chaud lors de l'opération.

NE PAS toucher. Gardez les enfants, les vêtements, les meubles et les matériaux combustibles loin de l'espace désignée pour l'installation.

NE PAS connecter cet appareil à un tuyau de cheminée servant un autre appareil.

Le plancher de l'espace désigné pour l'installation doit être fait de matière non-combustible, de 18" en avant, et de 8" de chaque côté des portes d'entrée du combustible.

In the event of loss of electrical power:

Consult owner's manual for restarting your furnace after power is restored.

Dans le cas d'un manque d'électricité:

Consultez le manuel du propriétaire pour remettre la fournaise en marche lorsque l'électricité est revenue.

Manufactured by/Fabriqué par: Harman Stove Co.
352 Mountain House Rd. • Halifax, PA 17032

Date of Manufacture/Date de Fabrication

2004 2005 2006 Jan Feb Mar Apr May Jun Jul Aug Sep Oct Nov Dec



Made in U.S.A./Fait aux États-Unis Do Not Remove or Cover This Label/Ne pas enlever ou recouvrir cette étiquette

Quick Reference (Auto-Light)

- 1 Turn Mode Selector to OFF.
- 2 Use shaker handle to clean the heat exchanger tubes.**
- 3 Scrape the air holes in the burnpot.**
- 4 Fill the hopper with pellets.
- 5 Turn Feed Adjuster to "Test".*
- 6 Check the Combustion Blower and Feeder Motor for operation.*
- 7 Turn Feed Adjuster back to the #4 setting.
- 8 Turn the Wall Control to the desired temperature.
- 9 Turn all of the Furnace Control knobs to the settings shown.*
- 10 Flip the Auto-Light switch up.*

The furnace will ignite if the temperature in the room is less than the temperature set on the Wall Control.

***See the section on Operation for information about Manual Lighting and Emergency Power.**

****See the section on Maintenance for more details about cleaning.**

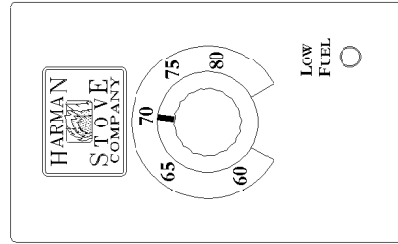
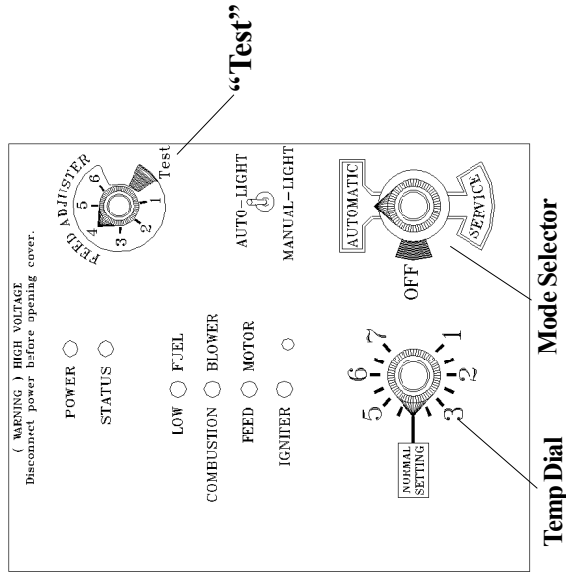

Wall Control

Free Manuals Download Website

<http://myh66.com>

<http://usermanuals.us>

<http://www.somanuals.com>

<http://www.4manuals.cc>

<http://www.manual-lib.com>

<http://www.404manual.com>

<http://www.luxmanual.com>

<http://aubethermostatmanual.com>

Golf course search by state

<http://golfingnear.com>

Email search by domain

<http://emailbydomain.com>

Auto manuals search

<http://auto.somanuals.com>

TV manuals search

<http://tv.somanuals.com>