

H A S S E L B L A D View Camera solutions

With digital photography it has become easier to work the tilt/shift mechanism of a view camera and hereby achieve a special photographic expression. The digital solutions however, are still heavy to bring into the field, and controls to place the wanted focus correctly are not optimal.

New ground breaking developments on the H3D camera system allow for direct tilt/shift work using the new HTS1.5 tilt/shift adapter, and the new HVC view camera adapter kit allows for classic view camera work both un-tethered and with new levels of focus control.

View Camera Connectivity

All Hasselblad digital camera products can work with view cameras.

Both the H3D camera products and the CF range of digital backs have a sophisticated interface, and allow micro-processor controlled connections to electronic shutters for full control capture mode (single-shot, multi-shot) and of aperture, shutter and exposure.

The remaining digital products are triggered by a simple flash sync connection. A summary is outlined in the table below.

The digital capture unit of the H3D and the 503CWD camera products can be removed and mounted on a view camera platform.

The CF/CF-MS/CFV digital back can also be mounted onto a view camera platform.

Two options are available to physically attach the digital capture unit to the view camera. The first is known as a Live Video Adapter, as the only method of composing and focusing the image is done via the Live Video controls in Phocus. The second is the Sliding Adapter that allows use of a conventional ground glass screen for composition and the ability to then slide the back in place. These items are easily obtainable from third party suppliers.

Please refer to links at the end of the Datasheet.



View Camera Connectivity

Hasselblad Product	Flash Sync	Flash Sync Used with Electronic Shutter*	Electronic Shutter with Full Control
H3D, H3DII, H3DII-MS	Yes	Yes	Yes
CF, CF-MS	Yes	Yes	Yes
503CWD, CFV	Yes	Yes	No

*If using an electronic shutter via flash sync connections, please note it will NOT be possible to control shutter and aperture values from Phocus.

HASSELBLAD View Camera solutions

New H3D sliding adapter kit

For working with view cameras Hasselblad has developed a View Camera adapter kit, specially suited for attaching the H3D camera products to a view camera

The H3D View Camera adapter kit (HVC) is mounted on a Linhof sliding adapter with few simple modifications. The adapter kit makes room for working directly with a number of the H3D elements to achieve not only the outstanding quality from the capture unit, but also full benefit from the large and bright view finders with ground glass, and the battery grip for external power operation.

The Linhof adapter is available from Linhof. The H3D View Camera adapter kit also works with existing Linhof adapters in the field.

The H3D View Camera adapter kit includes:

- mount for H3D ground glass and viewfinder (prism, or waist level)
- mounting plate for H3D digital capture unit (position for portrait and landscape)
- mount for H3D battery (for working un-tethered)
- cable for connecting to Rollei or Schneider electronic shutters

The H3D digital capture products connect to the electronic shutters/lenses with special connecting cables for the Schneider and for the Rollei electronic shutter. The cables work with both new shutters and shutters in the field.

Having connected the elements of the view camera solution, you simply choose your capture mode in Phocus. From now your controls when working tethered include:

- exposure time
- aperture
- capture single shot
- capture multi shot (for H3DII-MS products)
- live video

Working un-tethered the control of the electronic shutters takes place from the user interface on the digital capture unit.

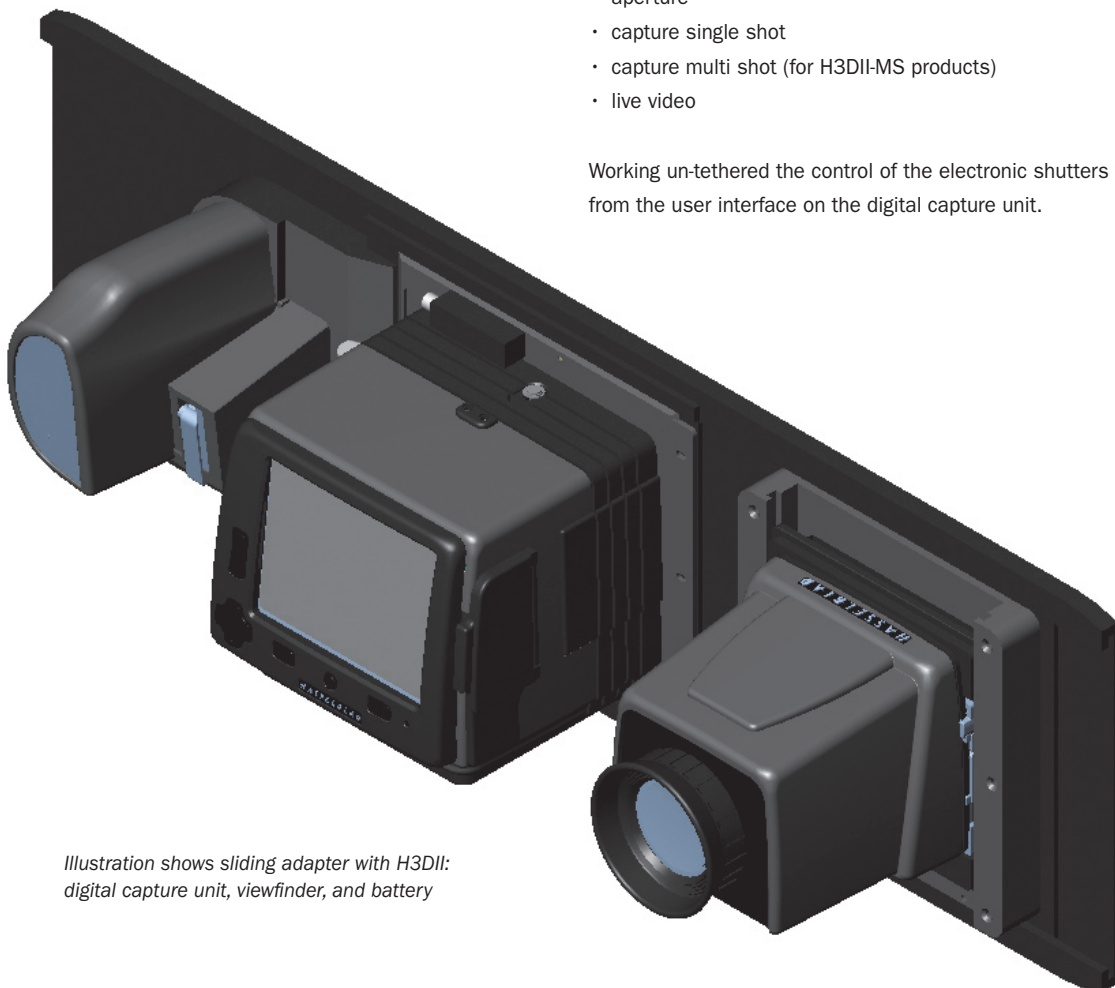
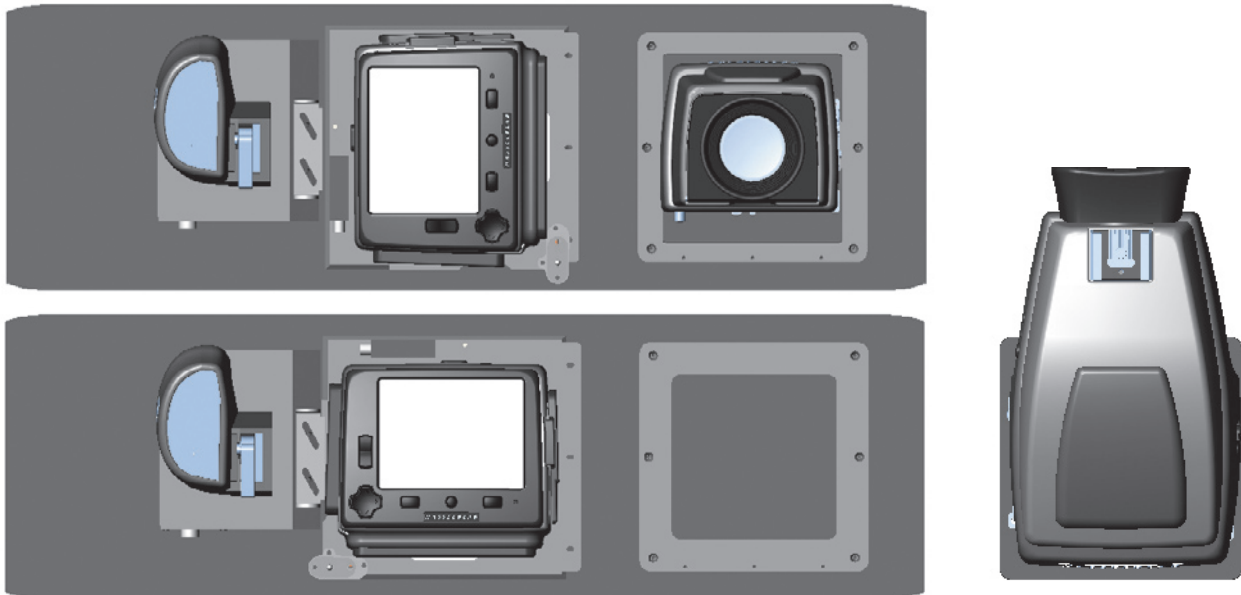

Illustration shows sliding adapter with H3DII: digital capture unit, viewfinder, and battery

HASSELBLAD View Camera solutions



Flexibility with regards to landscape/portrait work, and choice of view-finder system.

New HTS1.5 tilt/shift adapter solutions

For its H3DII camera products Hasselblad also offers the simple HTS1.5 tilt/shift adapter solution, which enlarges the image circle and thereby provides for a light, portable, easy to use solution with a +/- 18mm shift (half image size) and +/-10 degrees of tilt. The adapter works with 4 lenses: HCD 28mm, HC35mm, HC50mm, and HC80mm.



Illustration shows: H3DII-31 with the HTS1.5 adapter and the HCD 28mm lens. For details, please refer to separate datasheet.

H A S S E L B L A D View Camera solutions

CF-line digital back solutions for View Cameras

If you are used to focus and compose you images using the live video functionality, then you can mount the CF-line digital backs directly onto a view camera with H-camera or V-camera interface, using corresponding i-adapters on the CF digital back.

If you prefer to focus and compose using a ground glass with a loupe Hasselblad can recommend sliding adapters from Linhof - available with interface for either the i-adapter for a H-camera or for a V-camera. The sliding adapter is available from Linhof. A number of features including viewfinder, loupe, and ground glass are available.

Having connected the elements of the view camera solution, you simply choose your capture mode in Phocus.

From now your controls when working tethered include:

- exposure time
- aperture
- capture single shot
- capture multi shot (for CF-line multi shot products)
- live video

The CF-line digital backs connect to the electronic shutters/lenses with separate connecting cables for the Schneider or for the Rollei electronic shutter. See item numbers at the end of this document.

Working un-tethered the control of the electronic shutters takes place from the user interface on the digital capture unit.

Digital Lenses

Schneider and Rodenstock manufacture digital lenses, which can be supplied with the electronic shutter already fitted from Schneider or Rollei. This must be specified at ordering time. Equally, the view camera must have a front lens board that will accept the electronic shutter and lens. Rodenstock and Schneider can advise on the correct type of lens board for popular view cameras. Very wide angle lenses require recessed lens boards to get the lens physically close enough to the sensor in the digital capture unit. Please refer to links below for details on the lens program and availability.

General Connection Options - Manual Flash Sync

A method is required to physically trigger the lens shutter and the digital back simultaneously. This can be done via a very simple flash sync connection or via a sophisticated electronic interface.

Using a manual copal type lens, connection is made from the lens flash sync to the Sync In port on the digital unit. Therefore when the exposure is triggered on the lens, the digital unit receives a signal to expose simultaneously. If flash lighting is required then connection is made from the Sync Out port on the digital unit to the flash equipment. *This applies to all models.*

Flash Sync with Electronic Shutters

The use of an electronic shutter with a flash sync connection may be more convenient as it prevents the user disturbing the lens to adjust exposure settings or allow easier access to make these adjustments. Please note that using an electronic shutter in this way requires an interface from the manufacturer to allow Aperture selection, Shutter Speed and Capturing control.

Full Control with Electronic Shutters

Two systems are supported by Hasselblad, from Schneider and Rollei. Both of these systems comprise of a battery or mains powered control unit, connection interface to the electronic shutter/lens, connection interface to a digital capture unit and flash synchronisation output. The control unit will allow the user to select aperture setting, shutter speed and trigger the exposure.

HASSELBLAD View Camera solutions

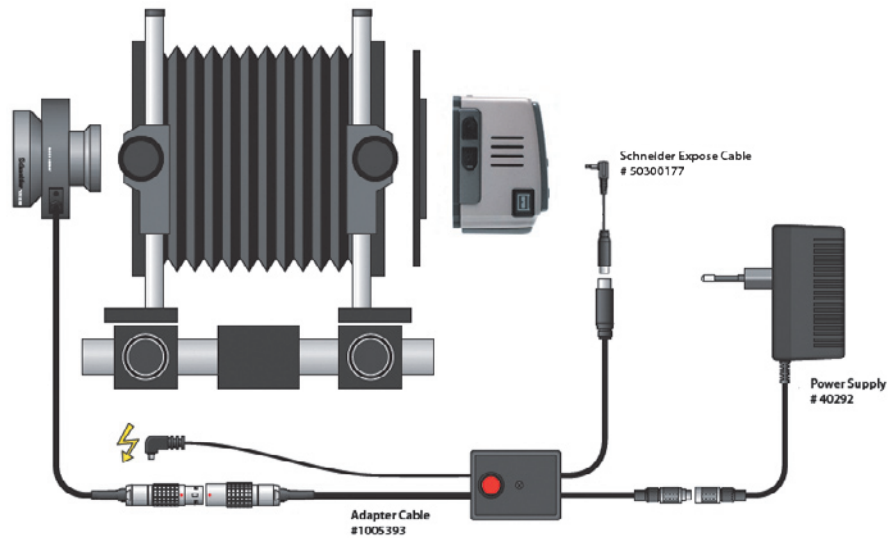

Schneider electronic shutter connections

This system works with a simple cable connection and small control box. This has a single red button that is only used for opening and closing the shutter for focus and composition. All aperture settings, shutter speeds and triggering capture are made from Phocus.

The yellow flash symbol indicates where external flash equipment can be connected. Schneider supplies all cables and equipment.

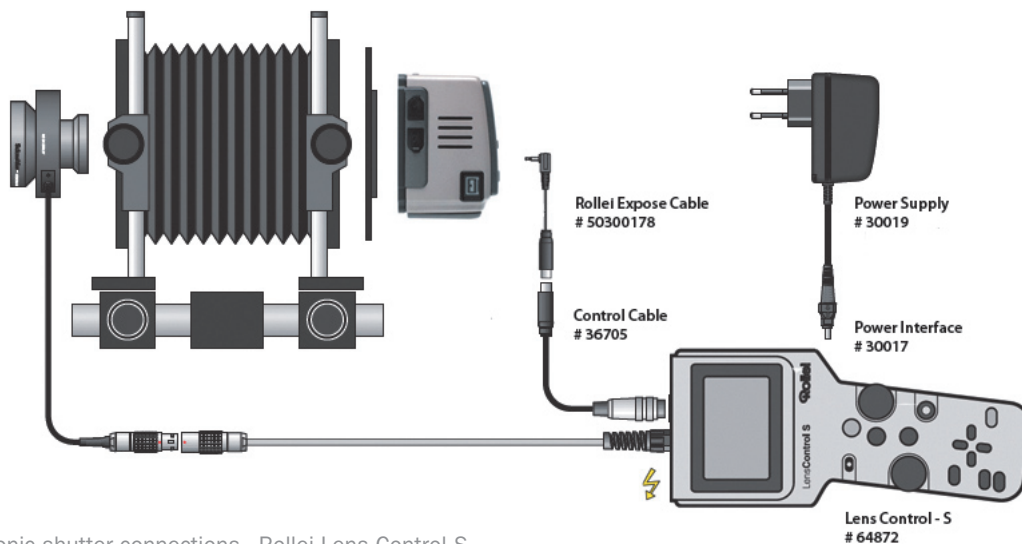

Rollei electronic shutter connections - Rollei Lens Control S

Unlike the Schneider system, the Rollei Lens Control - S must be used in conjunction with a control panel. This will allow use of the Hasselblad CF digital back in a studio or portable situation, either working tethered to FlexColor or working untethered capturing to Compact Flash media or the Image Bank.

The yellow flash symbol indicates where external flash equipment can be connected. Rollei supplies all cables and equipment with the exception of the Rollei Expose Cable #50300168.

H A S S E L B L A D View Camera solutions

Parts Summary and Links

ITEM	ITEM NO.	SUPPLIER
FLASH SYNC CONNECTION WITH MANUAL / COPAL SHUTTERS		
Camera Sync Cable from lens to digital capture unit	50300122	Hasselblad
Flash generator Sync Cable with protecting fuse	50300136	Hasselblad

FLASH SYNC CONNECTION WITH ELECTRONIC SHUTTERS – SCHNEIDER		
Power Supply / Charger	1001656	Schneider
Shutter Control ES	1001654	Schneider
Camera Sync Cable from lens to digital capture unit	50300122	Hasselblad
3 x NiMH 2200mA (AA size)	N/A	By user

FLASH SYNC CONNECTION WITH ELECTRONIC SHUTTERS – ROLLEI		
Power Supply	30019	Rollei
Power Interface	30017	Rollei
Camera Sync Cable from lens to digital capture unit	50300122	Hasselblad

FULL CONTROL WITH ELECTRONIC SHUTTERS – SCHNEIDER		
Adapter Cable	1005393	Schneider
Expose Cable	1006021	Schneider
Power Supply	40292	Schneider
H3D Expose Cable	50300177	Hasselblad
CF back Expose Cable	50300169	Hasselblad

FULL CONTROL WITH ELECTRONIC SHUTTERS – ROLLEI		
Lens Control-S	64872	Rollei
Power Supply	30019	Rollei
Power Interface	30017	Rollei
Control Cable	36705	Rollei
H3D Expose Cable	50300178	Hasselblad
CF back Expose Cable	50300168	Hasselblad

SLIDING ADAPTERS		
http://www.linhof.de/english/ From here please download brochure for M679cs. Specs are on page 10 and back cover.		Linhof

LENS MANUFACTURERS		
http://www.linos.com/pages/no_cache/home/shop-optik/rodenstock-foto-objektive/digitale-fachfotografie/#sid13372		Rodenstock/Linos
http://www.schneiderkreuznach.com/foto/dig/dig.htm		Schneider Kreuznach

Free Manuals Download Website

<http://myh66.com>

<http://usermanuals.us>

<http://www.somanuals.com>

<http://www.4manuals.cc>

<http://www.manual-lib.com>

<http://www.404manual.com>

<http://www.luxmanual.com>

<http://aubethermostatmanual.com>

Golf course search by state

<http://golfingnear.com>

Email search by domain

<http://emailbydomain.com>

Auto manuals search

<http://auto.somanuals.com>

TV manuals search

<http://tv.somanuals.com>