

HEALTHRIDER[®] PRO

H500i

Model No. HRTL71706.0

Serial No. _____

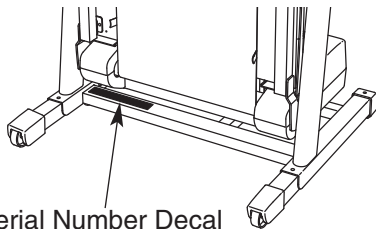

USER'S MANUAL

QUESTIONS?

As a manufacturer, we are committed to providing complete customer satisfaction. If you have questions, or if parts are damaged or missing, PLEASE CONTACT OUR CUSTOMER SERVICE DEPARTMENT DIRECTLY.

CALL TOLL-FREE:

1-888-922-4222

Mon.–Fri., 6 a.m.–6 p.m. MST

ON THE WEB:

www.healthriderservice.com



CAUTION

Read all precautions and instructions in this manual before using this equipment. Save this manual for future reference.



Visit our website at

www.healthrider.com

new products, prizes,
fitness tips, and much more!

HEALTHRIDER[®]PRO

H500i

TABLE OF CONTENTS

IMPORTANT PRECAUTIONS	3
BEFORE YOU BEGIN	5
ASSEMBLY	6
OPERATION AND ADJUSTMENT	10
HOW TO FOLD AND MOVE THE TREADMILL	17
TROUBLESHOOTING	19
CONDITIONING GUIDELINES	21
PART LIST	22
ORDERING REPLACEMENT PARTS	23
LIMITED WARRANTY	Back Cover

IMPORTANT PRECAUTIONS

⚠ WARNING: To reduce the risk of burns, fire, electric shock, or injury to persons, read the following important precautions and information before operating the treadmill.

1. It is the responsibility of the owner to ensure that all users of this treadmill are adequately informed of all warnings and precautions.
2. Use the treadmill only as described.
3. Place the treadmill on a level surface, with at least eight feet of clearance behind it and two feet on each side. Do not place the treadmill on any surface that blocks air openings. To protect the floor or carpet from damage, place a mat under the treadmill.
4. Keep the treadmill indoors, away from moisture and dust. Do not put the treadmill in a garage or covered patio, or near water.
5. Do not operate the treadmill where aerosol products are used or where oxygen is being administered.
6. Keep children under the age of 12 and pets away from the treadmill at all times.
7. The treadmill should be used only by persons weighing 300 pounds or less.
8. Never allow more than one person on the treadmill at a time.
9. Wear appropriate exercise clothes when using the treadmill. Do not wear loose clothes that could become caught in the treadmill. Athletic support clothes are recommended for both men and women. *Always wear athletic shoes. Never use the treadmill with bare feet, wearing only stockings, or in sandals.*
10. When connecting the power cord (see page 10), plug the power cord into a surge suppressor (not included) and plug the surge suppressor into a grounded circuit capable of carrying 15 or more amps. No other appliance should be on the same circuit. Do not use an extension cord.
11. Use only a single-outlet surge suppressor that meets all of the specifications described on page 10. To purchase a surge suppressor, see your local HealthRider dealer or call the toll-free telephone number on the front cover of this manual and order part number 146148, or see your local electronics store.
12. Failure to use a properly functioning surge suppressor could result in damage to the control system of the treadmill. If the control system is damaged, the walking belt may change speed, accelerate, or stop unexpectedly, which may result in a fall and serious injury.
13. Keep the power cord and the surge suppressor away from heated surfaces.
14. Never move the walking belt while the power is turned off. Do not operate the treadmill if the power cord or plug is damaged, or if the treadmill is not working properly. (See TROUBLESHOOTING on page 19 if the treadmill is not working properly.)
15. Read, understand, and test the emergency stop procedure before using the treadmill (see HOW TO TURN ON THE POWER on page 12).
16. Never start the treadmill while you are standing on the walking belt. Always hold the handrails while using the treadmill.
17. The treadmill is capable of high speeds. Adjust the speed in small increments to avoid sudden jumps in speed.
18. The pulse sensor is not a medical device. Various factors, including the user's movement, may affect the accuracy of heart rate readings. The pulse sensor is intended only as an exercise aid in determining heart rate trends in general.
19. Use the included dumbbells only as described in this manual. Properly store the dumbbells in the dumbbell holders on the console when you are not using them. If the dumbbells are improperly stored, they may fall off the console, causing the user to trip.

20. Never leave the treadmill unattended while it is running. Always remove the key, unplug the power cord, and switch the reset/off circuit breaker to the off position when the treadmill is not in use. (See the drawing on page 5 for the location of the circuit breaker.)

21. Do not attempt to raise, lower, or move the treadmill until it is properly assembled. (See ASSEMBLY on page 6, and HOW TO FOLD AND MOVE THE TREADMILL on page 17.) You must be able to safely lift 45 pounds (20 kg) to raise, lower, or move the treadmill.

22. When folding or moving the treadmill, make sure that the storage latch is fully closed.

23. Never insert any object into any opening on the treadmill.

⚠ WARNING: Before beginning this or any exercise program, consult your physician. This is especially important for persons over the age of 35 or persons with pre-existing health problems. Read all instructions before using. ICON assumes no responsibility for personal injury or property damage sustained by or through the use of this product.

SAVE THESE INSTRUCTIONS

24. Inspect and properly tighten all parts of the treadmill regularly.

25. **DANGER:** Always unplug the power cord immediately after use, before cleaning the treadmill, and before performing the maintenance and adjustment procedures described in this manual. Never remove the motor hood unless instructed to do so by an authorized service representative. Servicing other than the procedures in this manual should be performed by an authorized service representative only.

26. This treadmill is intended for in-home use only. Do not use this treadmill in a commercial, rental, or institutional setting.

The decals shown here have been placed on the treadmill. If a decal is missing, or if it is illegible, call the toll-free telephone number on the front cover of this manual and order a free replacement decal. Apply the decal in the location shown.

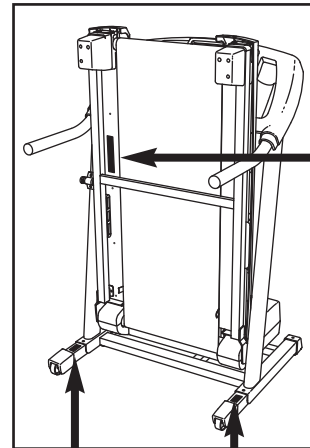

⚠ CAUTION
KEEP HANDS AND FEET AWAY FROM THIS AREA WHILE THE TREADMILL IS IN OPERATION.

⚠ WARNING:
Protect yourself and others from risk of serious injury. Read the user's manual and :

- Stand only on the side rails when starting or stopping treadmill.
- Change speed in small increments.
- Hold handrails to prevent falling, and always wear the safety clip while operating treadmill.
- Stop if you feel faint, dizzy, or short of breath.
- Fully engage storage latch before treadmill is moved or stored.
- Reduce incline to its lowest level before folding treadmill into storage position.
- Never allow children on or around treadmill.
- Remove key when not in use.
- Keep clothing, fingers, and hair away from moving belt.
- Never try to adjust or fix the belt while it is moving.
- Always wear athletic shoes while operating treadmill.

BEFORE YOU BEGIN

Thank you for selecting the HEALTHRIDER® PRO H500i treadmill. The PRO H500i treadmill offers an impressive array of features designed to make your workouts at home more enjoyable and effective. And when you're not exercising, the unique PRO H500i treadmill can be folded up, requiring less than half the floor space of other treadmills.

For your benefit, read this manual carefully before you use the treadmill. If you have questions after

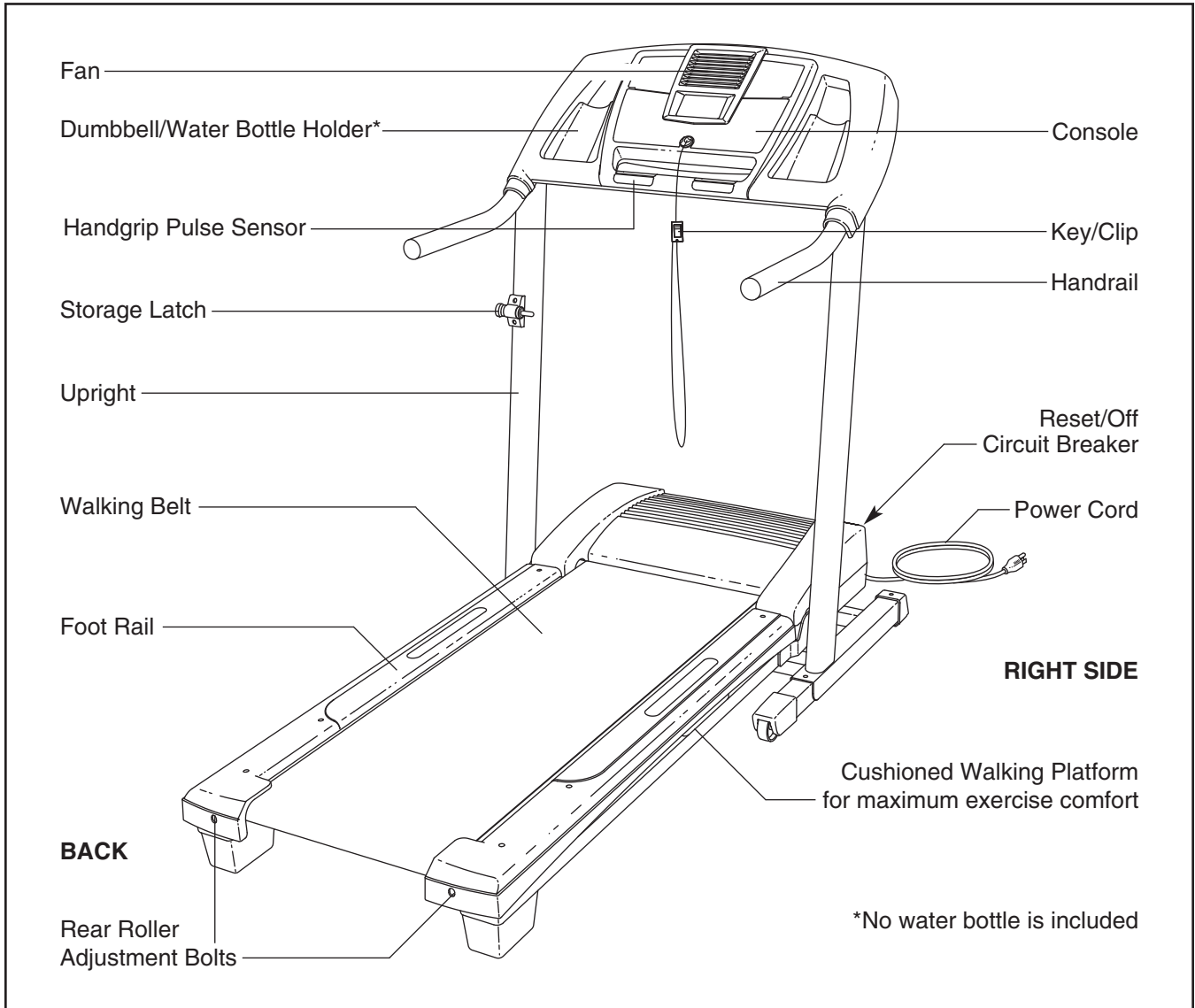

reading this manual, please see the front cover of this manual. To help us assist you, note the product model number and serial number before contacting us. The model number is found on the front cover of this manual. The serial number is found on a decal attached to the treadmill (see the front cover of this manual for the location of the decal).

Before reading further, please review the drawing below and familiarize yourself with the labeled parts.

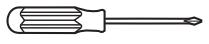

ASSEMBLY

Assembly requires two persons. Set the treadmill in a cleared area and remove all packing materials. Do not dispose of the packing materials until assembly is completed. Note: The underside of the treadmill walking belt is coated with high-performance lubricant. During shipping, a small amount of lubricant may be transferred to the top of the walking belt or the shipping carton. This is a normal condition and does not affect treadmill performance. If there is lubricant on top of the walking belt, simply wipe off the lubricant with a soft cloth and a mild, non-abrasive cleaner.

Assembly requires the included hex key  **and your own phillips screwdriver**  **(with a shaft at least 6" long) and wire cutters**  .

Use the drawings below to identify the hardware used during assembly. **Note: If a part is not in the parts bag, check to see if it has been preattached to one of the parts to be assembled. To avoid damaging plastic parts, do not use power tools for assembly.**

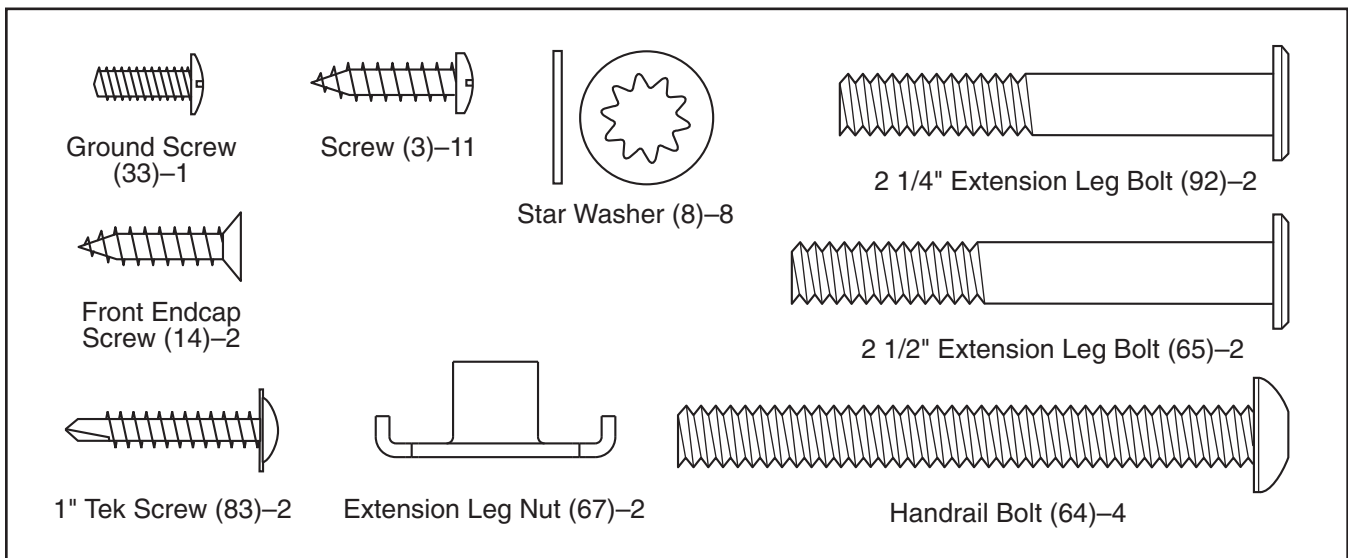

1. Make sure that the power cord is unplugged.

With the help of a second person, carefully tip the treadmill onto its left side as shown. Partially fold the Frame (58) so the treadmill is more stable. **Do not fully fold the Frame until the treadmill is completely assembled.**

Insert an Extension Leg (89) into the base of the Uprights (84). Hold an Extension Leg Nut (67) in the bottom of the Extension Leg, and thread a 2 1/4" Extension Leg Bolt (92) with a Star Washer (8) into the top of the Extension Leg. Next, thread a 2 1/2" Extension Leg Bolt (65) with a Star Washer (8) into the bottom of the Extension leg. **Firmly tighten the Extension Leg Bolts.**

Slide a Front Endcap (44) onto the base of the Uprights (84). Finger tighten a Front Endcap Screw (14) into the Front Endcap and the base.

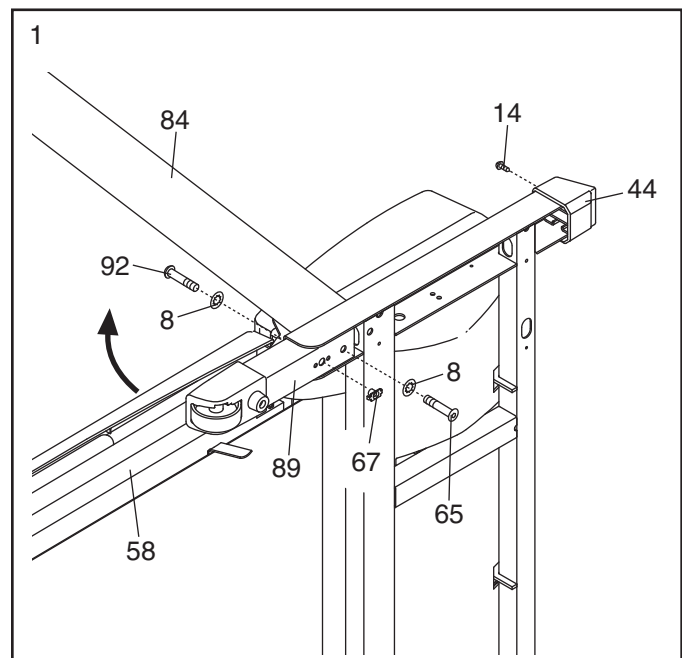

2. With the help of a second person, tip the treadmill onto its right side. **Do not fully fold the Frame (58) yet.**

Insert the other Extension Leg (89) into the base of the Uprights (84). Hold an Extension Leg Nut (67) in the bottom of the Extension Leg, and thread a 2 1/4" Extension Leg Bolt (92) with a Star Washer (8) into the top of the Extension Leg. Next, thread a 2 1/2" Extension Leg Bolt (65) with a Star Washer (8) into the bottom of the Extension leg. **Firmly tighten the Extension Leg Bolts.**

Slide the other Front Endcap (44) onto the base of the Uprights (84). Partially tighten a Front Endcap Screw (14) into the Front Endcap and the base.

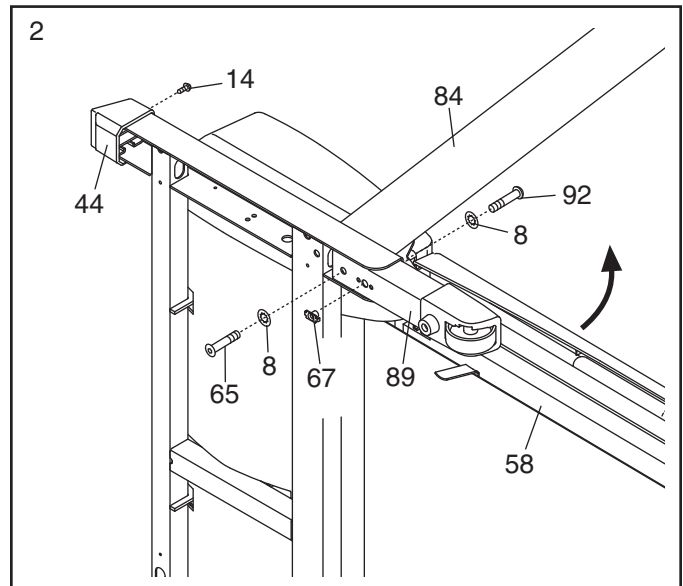

3. Attach two Base Pads (82) to the base of the Uprights (84) with two 1" Tek Screws (83).

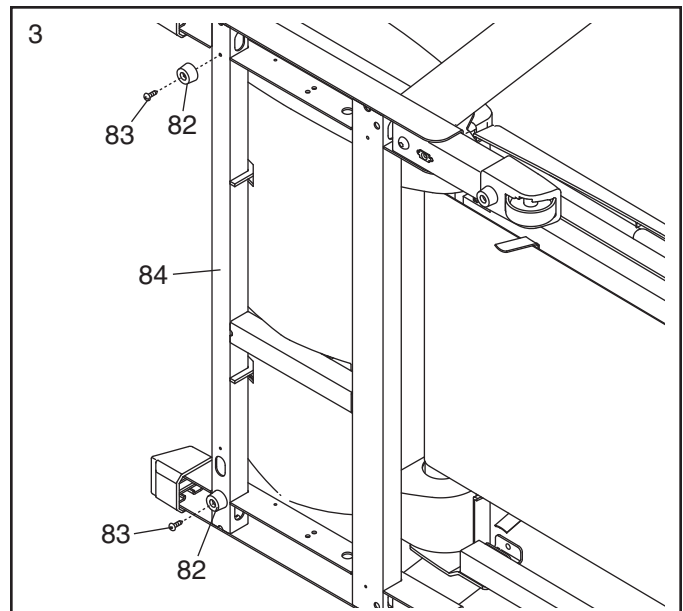

4. With the help of a second person, carefully raise the Uprights (84) to a vertical position.

Have the second person hold the Handrail (20) near the Uprights (84). Insert the Upright Wire Harness (77) into the hole in the bottom of the Handrail and out of the top as shown.

Next, set the Handrail (20) on the Uprights (84). **Do not let the Upright Wire Harness (77) fall into the right Upright.**

Attach the Handrail (20) with four Handrail Bolts (64) and four Star Washers (8); **start all four Handrail Bolts and then firmly tighten them.**

See steps 1 and 2. Fully tighten the two Front Endcap Screws (14).

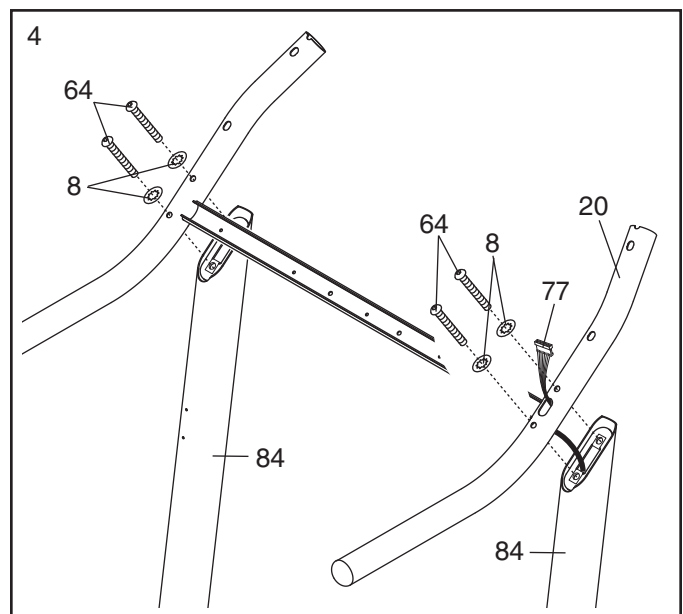

- While a second person holds the console assembly near the Handrail (20), attach the ground wire to the indicated hole in the Handrail with a Ground Screw (33).

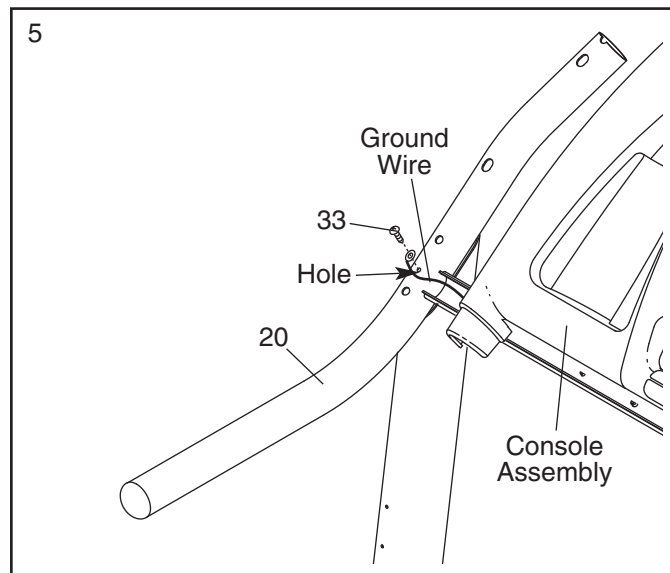

- While the second person continues to hold the console assembly, locate the wire underneath the console assembly.

Connect the wire from the console assembly to the Upright Wire Harness (77). **Make sure to connect the connectors properly (see the inset drawing). The connectors should slide together easily and snap into place.** If they do not, turn one connector and try again. **IF THE CONNECTORS ARE NOT CONNECTED PROPERLY, THE CONSOLE MAY BE DAMAGED WHEN THE POWER IS TURNED ON.** Then, insert the connectors downward into the Handrail (20).

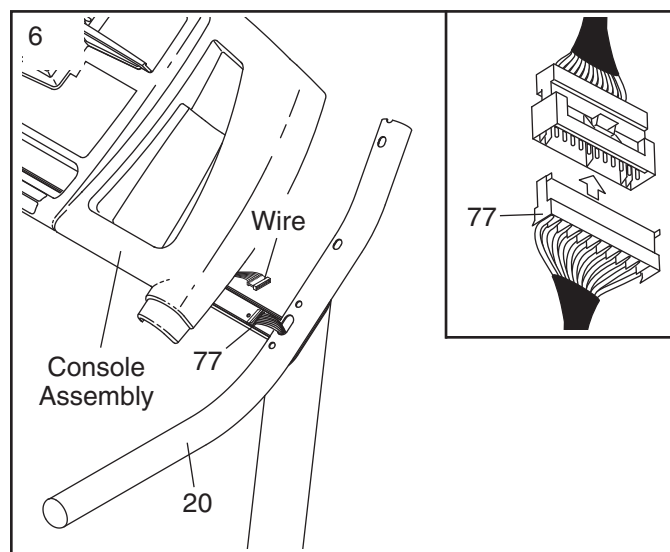

- Set the console assembly on the Handrail (20). **Be careful to avoid pinching any of the wires. Make sure that the ground wire (see step 5) and the wire from the console assembly (see step 6) are in the indicated channel.**

Hand tighten five Screws (3) into the Handrail (20) and the console assembly. **Do not put Screws into the two indicated holes. Start all five Screws, but do not tighten them yet.**

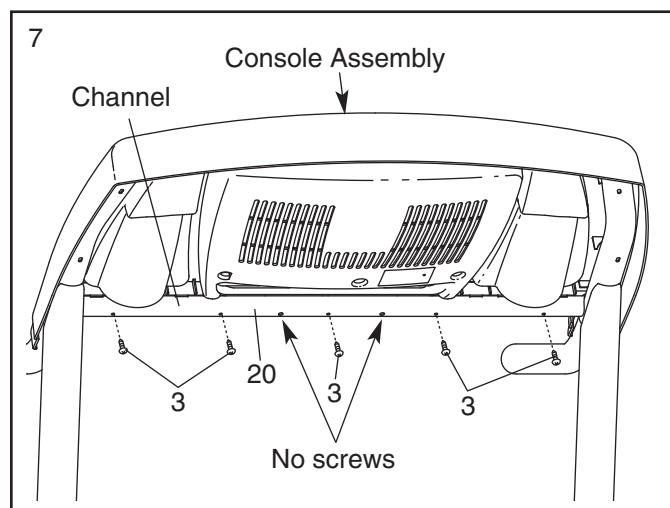

- Hand tighten four additional Screws (3) into the Handrail (20) and the console assembly. Then, **tighten all nine Screws used in step 7 and this step; do not overtighten the Screws.**

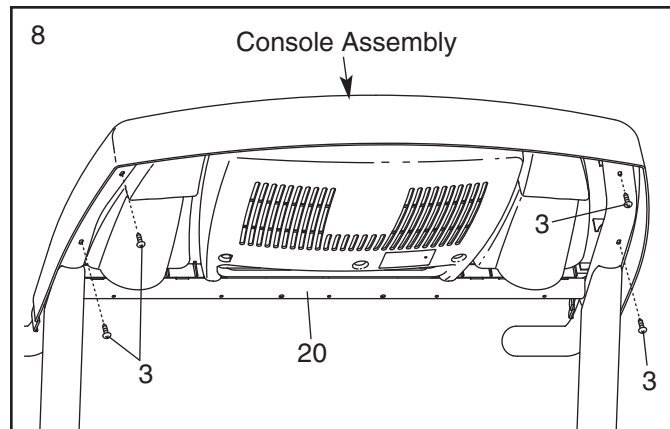

- Attach the Latch Housing (73) to the left Upright (84) with two Screws (3); **start both Screws and then tighten them. Note: Make sure that the large hole in the Latch Housing is on the indicated side.**

Remove the knob from the pin. Make sure that the collar and the spring are on the pin. (Note: If there are two collars, place one on each side of the spring.) Next, insert the pin into the Latch Housing (73). Then, tighten the knob onto the pin.

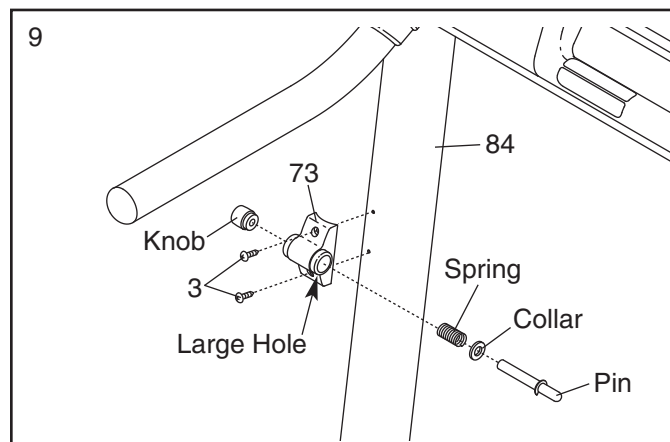

- Make sure that all parts are properly tightened before you use the treadmill.** If there are sheets of clear plastic on the treadmill decals, remove the plastic. To protect the floor or carpet, place a mat under the treadmill. Note: Extra hardware may be included. Keep the included hex key in a secure place; the large hex key is used to adjust the walking belt (see page 20).

If you purchase the optional chest pulse sensor (see page 16), follow the steps below to install the receiver included with the chest pulse sensor.

- Remove the key from the console and unplug the power cord.**

Remove the Screw (3) and the Access Door (76) from the back of the Console Base (85).

- Connect the wire on the receiver (A) to the indicated wire extending from the Console Base (85). **Hold the receiver so the small cylinder is oriented as shown and is facing the Console Base.** Attach the receiver to the plastic posts on the Access Door (76) with the two included small screws.

- Make sure that no wires are pinched.** Reattach the Access Door (76) with the Screw (3). Discard the other wires included with the receiver.

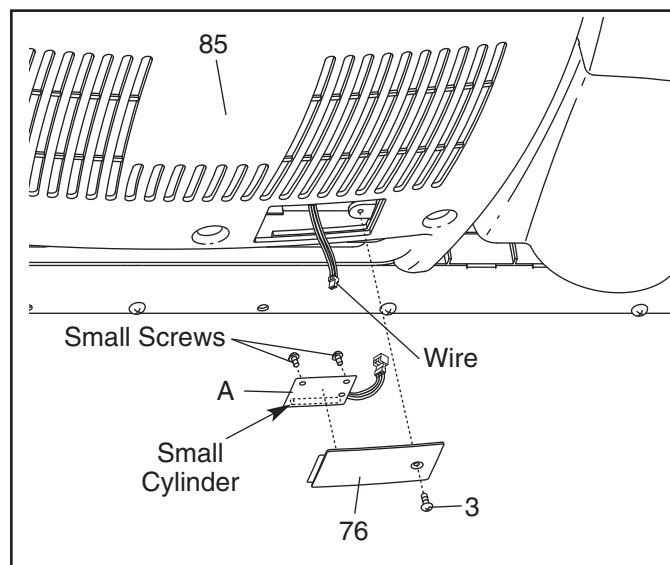

OPERATION AND ADJUSTMENT

THE PRE-LUBRICATED WALKING BELT

Your treadmill features a walking belt coated with high-performance lubricant. **IMPORTANT: Never apply silicone spray or other substances to the walking belt or the walking platform. Such substances will deteriorate the walking belt and cause excessive wear.**

HOW TO PLUG IN THE POWER CORD

⚠ DANGER: Improper connection of the equipment-grounding conductor can result in an increased risk of electric shock. Check with a qualified electrician or serviceman if you are in doubt as to whether the product is properly grounded. Do not modify the plug provided with the product—if it will not fit the outlet, have a proper outlet installed by a qualified electrician.

Your treadmill, like any other type of sophisticated electronic equipment, can be seriously damaged by sudden voltage changes in your home's power. Voltage surges, spikes, and noise interference can result from weather conditions or from other appliances being turned on or off. **To decrease the possibility of your treadmill being damaged, always use a surge suppressor with your treadmill (see drawing 1 at the right).** To purchase a surge suppressor, see your local HEALTHRIDER dealer or call the toll-free telephone number on the front cover of this manual and order part number 146148, or see your local electronics store.

Use only a single-outlet surge suppressor that is UL 1449 listed as a transient voltage surge suppressor (TVSS). The surge suppressor must have a UL suppressed voltage rating of 400 volts or less and a minimum surge dissipation of 450 joules. The surge suppressor must be electrically rated for 120 volts AC and 15 amps. There must be a monitoring light on the surge suppressor to indicate whether it is functioning properly. Failure to use a properly functioning surge suppressor could result in damage to the control system of the treadmill. If the control system is damaged, the walking belt may change speed, accelerate or stop unexpectedly, which may result in a fall and serious injury.

This product must be grounded. If it should malfunction or break down, grounding provides a path of least resistance for electric current, reducing the risk of elec-

tric shock. This product is equipped with a cord having an equipment-grounding conductor and a grounding plug. **Plug the power cord into a surge suppressor, and plug the surge suppressor into an appropriate outlet that is properly installed and grounded in accordance with all local codes and ordinances. Important: The treadmill is not compatible with GFCI-equipped outlets.**

This product is for use on a nominal 120-volt circuit, and has a grounding plug that looks like the plug illustrated in drawing 1 below. A temporary adapter that looks like the adapter illustrated in drawing 2 may be used to connect the surge suppressor to a 2-pole receptacle as shown in drawing 2 if a properly grounded outlet is not available.

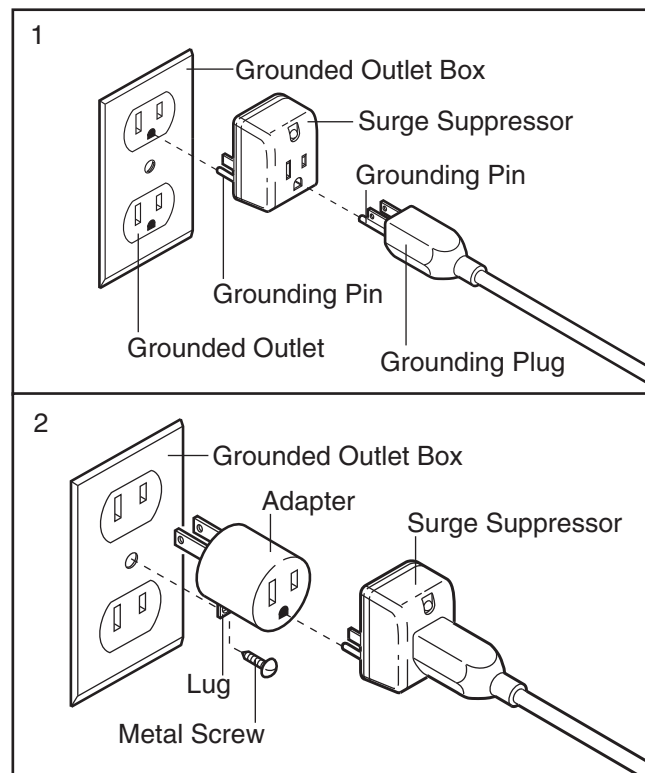

The temporary adapter should be used only until a properly grounded outlet (drawing 1) can be installed by a qualified electrician.

The green-colored rigid ear, lug, or the like extending from the adapter must be connected to a permanent ground such as a properly grounded outlet box cover. Whenever the adapter is used it must be held in place by a metal screw. **Some 2-pole receptacle outlet box covers are not grounded. Contact a qualified electrician to determine if the outlet box cover is grounded before using an adapter.**

CONSOLE DIAGRAM

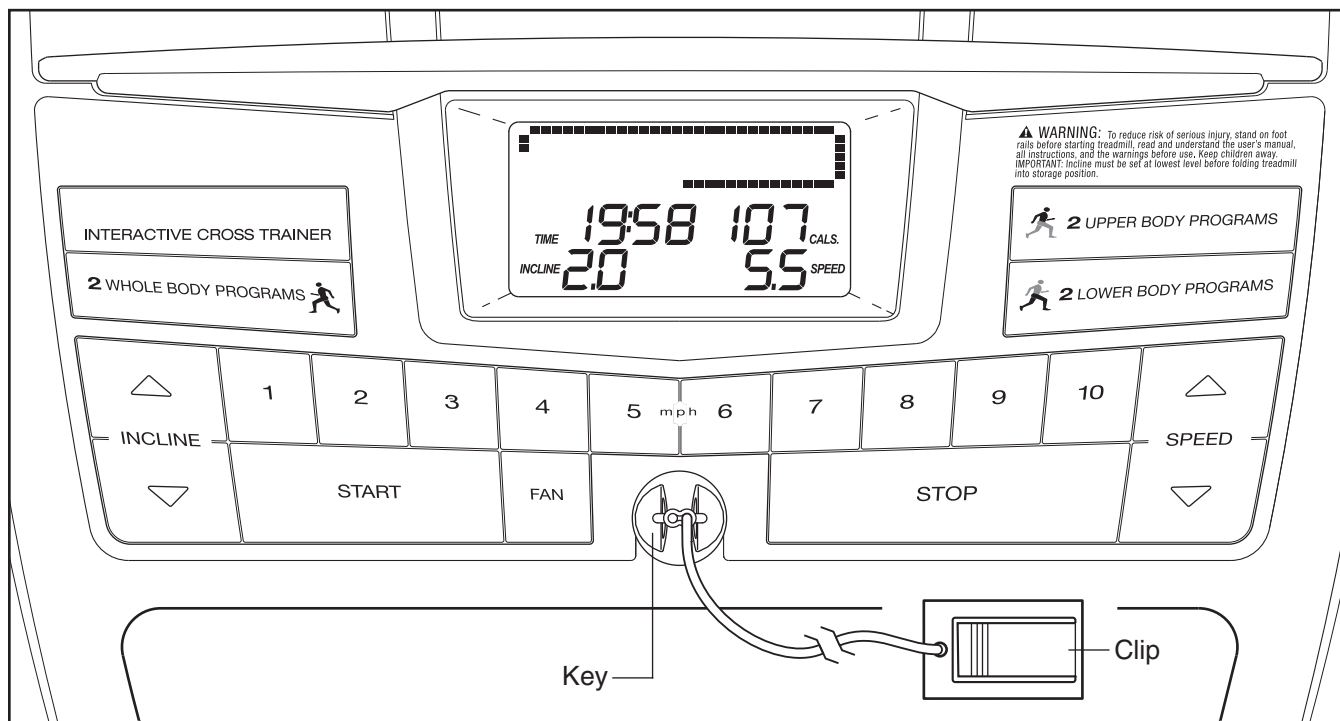

FEATURES OF THE CONSOLE

The revolutionary treadmill console offers a selection of features designed to make your workouts more effective.

When you select the manual mode of the console, you can change the speed and incline of the treadmill with the touch of a button. As you exercise, the console will display continuous exercise feedback. You can even measure your heart rate using the handgrip pulse sensor or the optional chest pulse sensor (see page 16 for information about the optional chest pulse sensor).

The console also features six interactive cross trainer programs designed to help you to burn calories and enhance your cardiovascular system while toning and strengthening your muscles. The cross trainer programs automatically control the speed and incline of the treadmill and prompt you to perform a variety of

strength exercises during your workout. There are two whole body, two upper body, and two lower body cross trainer programs to choose among. Note: The strength exercises require the use of dumbbells and an inflatable exercise ball (not included). **To purchase dumbbells or an exercise ball, call the toll-free telephone number on the front cover of this manual.**

To use the manual mode of the console, follow the steps beginning on page 12. **To use a cross trainer program**, see page 14.

Note: If there is a sheet of clear plastic on the face of the console, remove the plastic. To prevent damage to the walking platform, wear clean athletic shoes while using the treadmill. The first time the treadmill is used, observe the alignment of the walking belt, and center the walking belt if necessary (see page 20).

HOW TO TURN ON THE POWER

- 1 Plug in the power cord (see page 10).
- 2 Locate the reset/off circuit breaker near the power cord. Make sure that the circuit breaker is in the reset position.

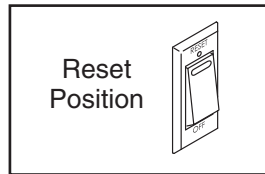

- 3 Next, stand on the foot rails of the treadmill. Find the clip attached to the key (see the drawing on page 11) and slide the clip onto the waistband of your clothes. Then, insert the key into the console. After a moment, the display will light. **Important: In an emergency situation, the key can be pulled from the console, causing the walking belt to slow to a stop. Test the clip by carefully taking a few steps backward; if the key is not pulled from the console, adjust the position of the clip.**

HOW TO USE THE MANUAL MODE

- 1 Insert the key into the console.
See HOW TO TURN ON THE POWER above.

- 2 Select the manual mode.

When the key is inserted, the manual mode will be selected. If a program has been selected, reselect the manual mode by pressing any of the three Programs buttons repeatedly until a track appears in the display.

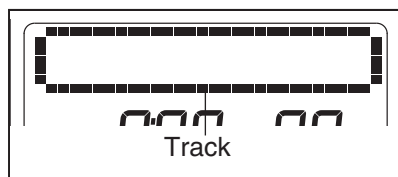

- 3 Start the walking belt.

To start the walking belt, press the Start button, the Speed increase button, or one of the speed buttons numbered 1 to 10.

If the Start button or the Speed increase button is pressed, the walking belt will begin to move at 1 mph. As you exercise, change the speed of the walking belt as desired by pressing the Speed increase and decrease buttons. Each time a button is pressed, the speed setting will change by 0.1 mph; if a button is held down, the speed setting will change in increments of 0.5 mph. Note: After the buttons are pressed, it may take a moment for the walking belt to reach the selected speed setting.



If one of the numbered speed buttons is pressed, the walking belt will gradually change speed until it reaches the selected speed setting.

To stop the walking belt, press the Stop button. The time will begin to flash in the display. To restart the walking belt, press the Start button, the Speed increase button, or one of the numbered speed buttons.

- 4 Change the incline of the treadmill as desired.

To change the incline of the treadmill, press the Incline increase and decrease buttons. Each time a button is pressed, the incline will change by 0.5%. Note: After the buttons are pressed, it may take a moment for the treadmill to reach the selected incline setting.



- 5 Follow your progress with the display.

When the manual mode is selected, the display will show a track that represents

1/4 mile. As you walk or run, indicators will appear in succession around the track until the entire track appears. The track will then disappear and the indicators will again begin to appear in succession.

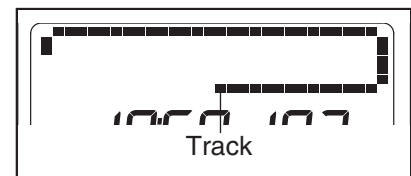

The left side of the display will show the elapsed time, the distance that you have walked or run, and the incline level of the treadmill. Note: When a program is selected, the display will show the time remaining in the program instead of the elapsed time.



The right side of the display will show the approximate number of calories you have burned while walking or running, the speed of the walking belt, and your pace in minutes per mile. The right side of the display will also show your heart rate when you use the handgrip pulse sensor or the optional chest pulse sensor.



Note: The console can display speed and distance in either miles or kilometers. To find out which unit of measurement is selected or to change the unit of measurement, see THE INFORMATION MODE/DEMO MODE on page 16. **Note: For simplicity, all instructions in this section refer to miles.**

To reset the display, press the Stop button, remove the key, and then reinsert the key.

6 Measure your heart rate if desired.

Note: If you use the handgrip pulse sensor and the optional chest pulse sensor at the same time, the console will not display your heart rate accurately.

Before using the handgrip pulse sensor, remove the sheets of clear plastic from the metal contacts. In addition, make sure that your hands are clean.

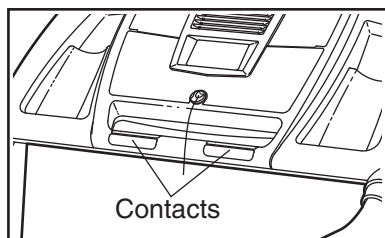

To measure your heart rate, **stand on the foot rails** and hold the metal contacts on the handrail—**avoid moving your hands**. When your pulse is detected, one or two dashes will appear in the right side of the display and then your heart rate will be shown. **For the most accurate heart rate reading, continue to hold the contacts for about 15 seconds.**

7 Turn on the fan if desired.

To turn on the fan, press the Fan button. To turn on the fan at high speed, press the button a second time. To turn off the fan, press the button a third time. Note: If the fan is on when the walking belt stops, the fan will automatically turn off after a few minutes.

8 When you are finished exercising, remove the key.

Step onto the foot rails, press the Stop button, and **adjust the incline of the treadmill to the lowest setting. The incline must be at the lowest setting when the treadmill is folded to the storage position or the treadmill will be damaged.** Next, remove the key from the console and put it in a secure place. **Note: If the display remains lit after the key is removed, the console is in the “demo” mode. See page 16 and turn off the demo mode.**

When you are finished using the treadmill, switch the reset/off circuit breaker to the “off” position and unplug the power cord.

HOW TO USE A CROSS TRAINER PROGRAM

1 Insert the key into the console.

See HOW TO TURN ON THE POWER on page 12.

2 Select one of the six cross trainer programs.

To select a cross trainer program, press one of the three Programs buttons repeatedly until "P 1,"

"P 2," "P 3," "P 4," "P 5," or "P 6" appears in the display. When a cross trainer program is selected, the program time will appear in the display, the maximum incline setting of the program and the maximum speed setting of the program will flash in the display for a few seconds, and a profile of the speed settings of the program will scroll across the matrix in the display.

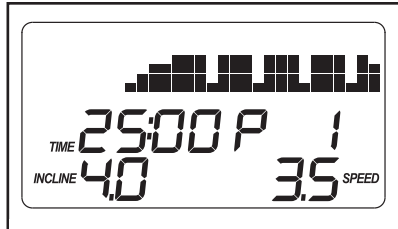

3 Press the Start button or the Speed increase button to start the program.

A moment after the button is pressed, the treadmill will automatically adjust to the first speed and incline settings of the program. Hold the handrails and begin walking.

Each program is divided into 25, 30, or 45 one-minute segments. One speed setting and one incline setting are programmed for most segments. (Note: The same speed setting and/or incline setting may be programmed for two or more consecutive segments.) During other segments, the console will prompt you to perform strength exercises.

The speed setting for the first segment will be shown in the flashing Current Segment column of the matrix.

(The incline settings are not shown in the matrix.) The speed set-



tings for the next several segments will be shown in the columns to the right.

When only three seconds remain in the first segment of the program, both the Current Segment column and the column to the right will flash and a series of tones will sound. If the speed and/or incline of the treadmill is about to change, the speed setting and/or the incline setting will flash in the display to alert you.

When the first segment is completed, *all speed settings will move one column to the left.* The speed setting for the second segment will then be shown in the flashing Current Segment column and the treadmill will automatically adjust to the speed and incline settings for the second segment. Note: If all of the indicators in the Current Segment column are lit, *the speed settings may move downward* so that only the highest indicators appear in the matrix.

If the speed or incline setting for the current segment is too high or too low, you can manually override the setting by pressing the Speed and Incline buttons. Every few times a Speed button is pressed, an additional indicator will appear or disappear in the Current Segment column; if any of the columns to the right of the Current Segment column have the same number of lit indicators as the Current Segment column, an additional indicator may appear or disappear in those columns as well. **Important: When the current segment of the program ends, the treadmill will automatically adjust to the speed and incline settings for the next segment.**

To stop the program at any time, press the Stop button. The time will begin to flash in the display. To restart the program, press the Start button or the Speed increase button. The walking belt will begin to move at 1 mph. When the next segment of the program begins, the treadmill will automatically adjust to the speed and incline settings for that segment.

4 Perform the first strength exercise when prompted.

When the first strength exercise segment begins (only one indicator will flash in the Current Segment column), the walking belt will slow to a stop and the name of the first strength exercise will appear in the display for a few seconds.

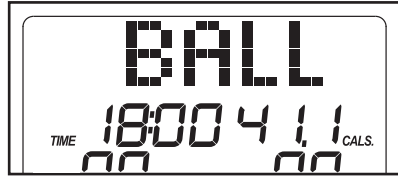

Next, the display will show the recommended number of repetitions for the first strength exercise.



Remove the clip from the waistband of your clothes, step off the treadmill, and prepare to begin the first strength exercise. Every few seconds, the console will sound a tone; when a tone sounds, perform one repetition of the exercise. Exercise with a slow, steady motion; do not perform more than one repetition each time a tone sounds. The display will count down the repetitions as you perform them.

Note: Refer to the accompanying exercise chart to see the correct form for each exercise. When performing lunges, alternate legs with each repetition. When performing dumbbell rows, perform half the

repetitions with your right arm and half the repetitions with your left arm. The strength exercises require the use of dumbbells and an inflatable exercise ball (not included). **To purchase dumbbells or an exercise ball, call the toll-free telephone number on the front cover of this manual.**

5 Continue the cross trainer program.

When you have performed the recommended number of repetitions, the words PRESS START will appear in the display. To continue the cross trainer program, step onto the treadmill, **slide the clip back onto the waistband of your clothes**, and press the Start button. The treadmill will automatically adjust to the speed and incline settings for the next segment.

The program will continue in this way until the last segment ends. The walking belt will then slow to a stop.

6 Follow your progress with the display.

See step 5 on pages 12 and 13.

7 Measure your heart rate if desired.

See step 6 on page 13.

8 Turn on the fan if desired.

See step 7 on page 13.

9 When you are finished exercising, remove the key from the console.

See step 8 on page 13.

THE INFORMATION MODE/DEMO MODE

The console features an information mode that keeps track of treadmill usage information. The information mode also allows you to select miles or kilometers as the unit of measurement and to turn on and turn off the demo mode.

To select the information mode, hold down the Stop button, insert the key into the console, and then release the Stop button. When the information mode is selected, the following information will appear in the display:

The center of the display will show the total number of hours that the treadmill has been operated. The lower part of the display will show total num-

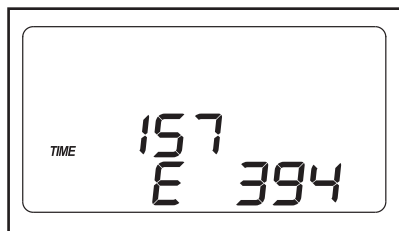

ber of miles or kilometers that the walking belt has moved. In addition, an "E" for English miles or an "M" for metric kilometers will appear in the lower part of the display. To change the unit of measurement, press the Speed increase button.

IMPORTANT: If a "d" appears in the display, the console is in the "demo" mode. This mode is intended to be used only when a treadmill is displayed in a store. When the console is in the demo mode, the power cord can be plugged in, the key can be removed from the console, and the indicators in the display will automatically appear in a preset sequence; the buttons on the console will not operate. **If a "d" appears when the information mode is selected, press the Speed decrease button so that the "d" disappears.**

To exit the information mode, remove the key from the console.

THE OPTIONAL CHEST PULSE SENSOR

An optional chest pulse sensor offers hands-free operation as it tracks your heart rate during your workouts. **To purchase the optional chest pulse sensor, call the toll-free telephone number on the front cover of this manual.**

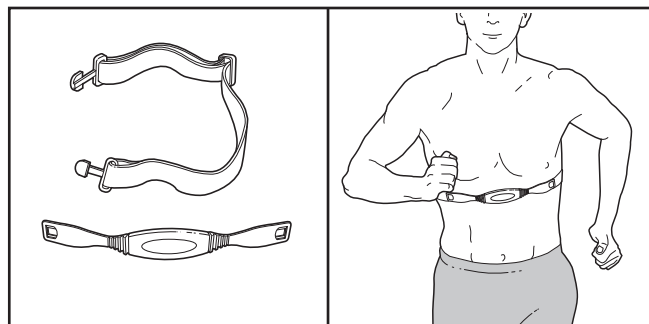

HOW TO FOLD AND MOVE THE TREADMILL

HOW TO FOLD THE TREADMILL FOR STORAGE

Before folding the treadmill, adjust the incline to the lowest position. If this is not done, the treadmill may become permanently damaged. Next, unplug the power cord. **CAUTION:** You must be able to safely lift 45 pounds (20 kg) to raise, lower, or move the treadmill.

1. Hold the metal frame firmly in the location shown by the arrow at the right. **CAUTION:** To decrease the possibility of injury, do not lift the frame by the plastic foot rails. To raise the frame, bend your legs, keep your back straight, and lift with your legs. Raise the frame about halfway to the vertical position.

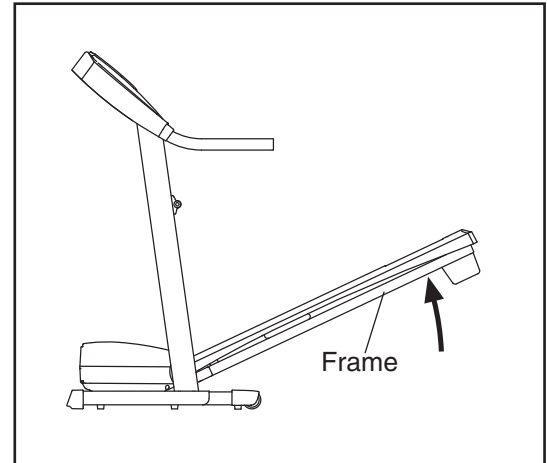

2. Move your right hand to the position shown and hold the treadmill firmly. Using your left hand, pull the latch knob to the left and hold it. Raise the frame until the latch pin is aligned with the gap between the frame and the foot rail. Slowly release the latch knob. **Make sure that the latch pin is fully inserted between the frame and the foot rail.**

To protect the floor or carpet from damage, place a mat under the treadmill. Keep the treadmill out of direct sunlight. Do not leave the treadmill in the storage position in temperatures above 85° Fahrenheit.

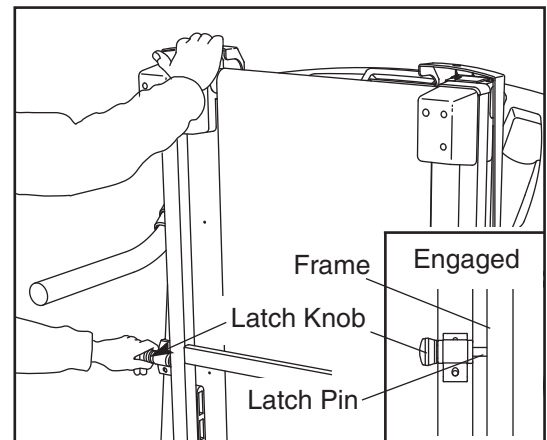

HOW TO MOVE THE TREADMILL

Before moving the treadmill, convert the treadmill to the storage position as described above. **Make sure that the latch pin is fully inserted between the frame and the foot rail.**

1. Hold the upper ends of the handrails. Place one foot against one of the wheels.
2. Tilt the treadmill backward until it rolls freely on the front wheels. Carefully move the treadmill to the desired location. **To reduce the risk of injury, use extreme caution while moving the treadmill. Do not move the treadmill over an uneven surface.**
3. Place one foot against one of the wheels, and carefully lower the treadmill until it is resting in the storage position.

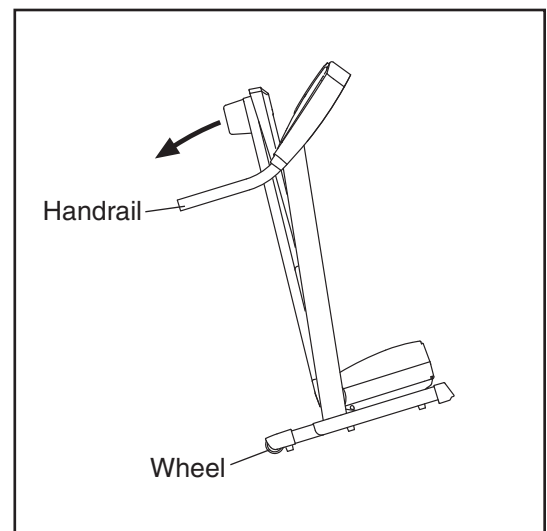

HOW TO LOWER THE TREADMILL FOR USE

1. Hold the upper end of the treadmill with your right hand. Pull the latch knob to the left and hold it. Pivot the frame downward until the frame and the footrail are past the latch pin.

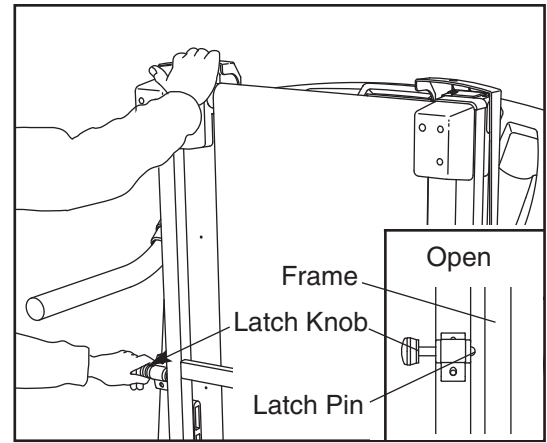

2. Hold the metal frame firmly with both hands, and lower it to the floor. **CAUTION: To decrease the possibility of injury, do not lower the frame by gripping only the plastic foot rails. Do not drop the frame to the floor. Make sure to bend your legs and keep your back straight.**

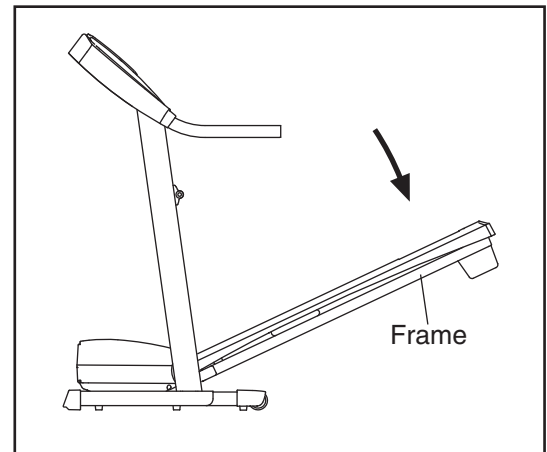

TROUBLESHOOTING

Most treadmill problems can be solved by following the steps below. Find the symptom that applies, and follow the steps listed. If you need further assistance, please see the front cover of this manual.

PROBLEM: The power does not turn on

SOLUTION: a. Make sure that the power cord is plugged into a surge suppressor, and that the surge suppressor is plugged into a properly grounded outlet (see page 10). Use only a single-outlet surge suppressor that meets all of the specifications described on page 10. Important: The treadmill is not compatible with GFCI-equipped outlets.

b. After the power cord has been plugged in, make sure that the key is inserted into the console.

c. Check the reset/off circuit breaker located on the treadmill frame near the power cord. If the switch protrudes as shown, the circuit breaker has tripped. To reset the circuit breaker, wait for five minutes, and then press the switch back in.

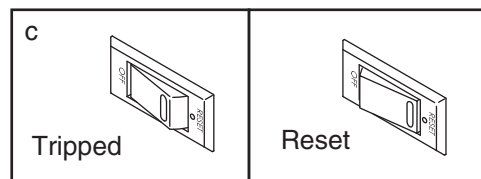

PROBLEM: The power turns off during use

SOLUTION: a. Check the reset/off circuit breaker (see the drawing above). If the circuit breaker has tripped, wait for five minutes and then press the switch back in.

b. Make sure that the power cord is plugged in. If the power cord is plugged in, unplug it, wait for five minutes, and then plug it back in.

c. Remove the key from the console. Reinsert the key into the console.

d. If the treadmill still will not run, see the front cover of this manual.

PROBLEM: The incline of the treadmill does not change correctly

SOLUTION: a. With the key in the console, press one of the Incline buttons. **While the incline is changing, remove the key.** After a few seconds, re-insert the key. The treadmill will automatically rise to the maximum incline level and then return to the minimum level. This will recalibrate the incline system.

PROBLEM: The display of the console does not function properly

SOLUTION: a. Remove the key from the console and **UNPLUG THE POWER CORD.** Remove the three hood Screws (7). Carefully pivot the Hood (41) off.

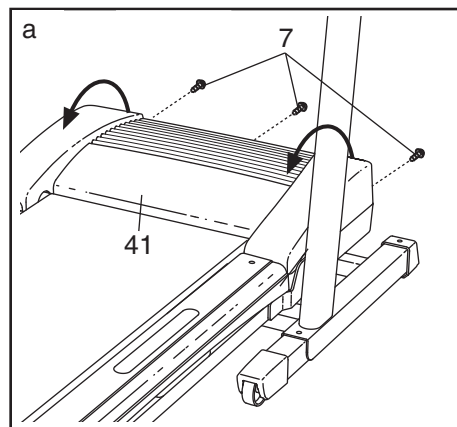

Locate the Reed Switch (63) and the Magnet (46) on the left side of the Pulley (47). Turn the Pulley until the Magnet is aligned with the Reed Switch. **Make sure that the gap between the Magnet and the Reed Switch is about 1/8"**. If necessary, loosen the Screw (33), move the Reed Switch slightly, and then retighten the Screw. Reattach the Hood (41), making sure that the hood Screws (7) are inserted into the same holes from which they were removed. Run the treadmill for a few minutes to check for a correct speed reading.

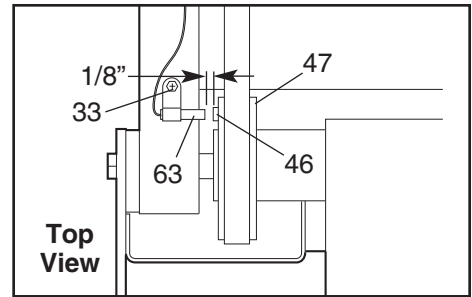

PROBLEM: The walking belt slows when walked on

SOLUTION: a. Use only a single-outlet surge suppressor that meets all the specifications described on page 10.

b. If the walking belt is overtightened, treadmill performance may decrease and the walking belt may become damaged. Remove the key and **UNPLUG THE POWER CORD**. Using the hex key, turn both rear roller bolts counterclockwise, 1/4 of a turn. When the walking belt is properly tightened, you should be able to lift each edge of the walking belt 2 to 3 inches above the walking platform. Be careful to keep the walking belt centered. Then, plug in the power cord, insert the key, and run the treadmill for a few minutes. Repeat until the walking belt is properly tightened.

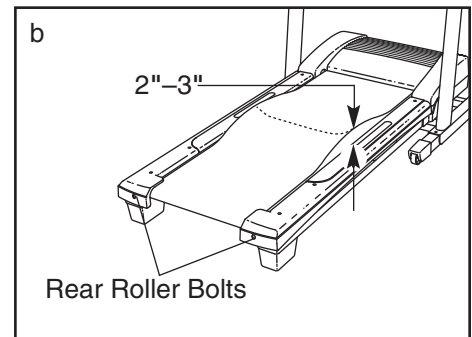

c. If the walking belt still slows when walked on, please see the front cover of this manual.

PROBLEM: The walking belt is off-center or slips when walked on

SOLUTION: a. **If the walking belt is off-center**, first remove the key and **UNPLUG THE POWER CORD**. **If the walking belt has shifted to the left**, use the hex key to turn the left rear roller bolt clockwise 1/2 of a turn; **if the walking belt has shifted to the right**, turn the left bolt counterclockwise 1/2 of a turn. Be careful not to overtighten the walking belt. Then, plug in the power cord, insert the key, and run the treadmill for a few minutes. Repeat until the walking belt is centered.

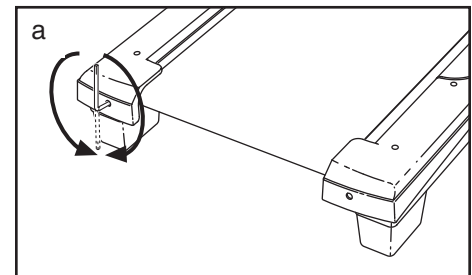

b. **If the walking belt slips when walked on**, first remove the key and **UNPLUG THE POWER CORD**. Using the hex key, turn both rear roller bolts clockwise, 1/4 of a turn. When the walking belt is correctly tightened, you should be able to lift each edge of the walking belt 2 to 3 inches above the walking platform. Be careful to keep the walking belt centered. Then, plug in the power cord, insert the key, and carefully walk on the treadmill for a few minutes. Repeat until the walking belt is properly tightened.

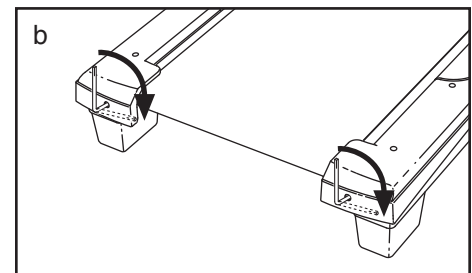

CONDITIONING GUIDELINES

⚠️ WARNING: Before beginning this or any exercise program, consult your physician. This is especially important for individuals over the age of 35 or individuals with pre-existing health problems.

The pulse sensor is not a medical device. Various factors, including your movement, may affect the accuracy of heart rate readings. The sensor is intended only as an exercise aid in determining heart rate trends in general.

The following guidelines will help you to plan your exercise program. For more detailed exercise information, obtain a reputable book or consult your physician.

EXERCISE INTENSITY

Whether your goal is to burn fat or to strengthen your cardiovascular system, the key to achieving the desired results is to exercise with the proper intensity. The proper intensity level can be found by using your heart rate as a guide. The chart below shows recommended heart rates for fat burning and aerobic exercise.

165	155	145	140	130	125	115	♥
145	138	130	125	118	110	103	♥
125	120	115	110	105	95	90	♥
20	30	40	50	60	70	80	

To find the proper heart rate for you, first find your age near the bottom of the chart (ages are rounded off to the nearest ten years). Next, find the three numbers above your age. The three numbers define your “training zone.” The lower two numbers are recommended heart rates for fat burning; the higher number is the recommended heart rate for aerobic exercise.

Fat Burning

To burn fat effectively, you must exercise at a relatively low intensity level for a sustained period of time. During the first few minutes of exercise, your body uses easily accessible *carbohydrate calories* for en-

ergy. Only after the first few minutes does your body begin to use stored *fat calories* for energy. If your goal is to burn fat, adjust the speed and incline of the treadmill until your heart rate is near the lowest number in your training zone.

For maximum fat burning, adjust the speed and incline of the treadmill until your heart rate is near the middle number in your training zone.

Aerobic Exercise

If your goal is to strengthen your cardiovascular system, your exercise must be “aerobic.” Aerobic exercise is activity that requires large amounts of oxygen for prolonged periods of time. This increases the demand on the heart to pump blood to the muscles, and on the lungs to oxygenate the blood. For aerobic exercise, adjust the speed and incline of the treadmill until your heart rate is near the highest number in your training zone.

WORKOUT GUIDELINES

Each workout should include the following three parts:

A Warm-up—Start each workout with 5 to 10 minutes of stretching and light exercise. A proper warm-up increases your body temperature, heart rate and circulation in preparation for exercise.

Training Zone Exercise—After warming up, increase the intensity of your exercise until your heart rate is in your training zone for 20 to 60 minutes. (During the first few weeks of your exercise program, do not keep your heart rate in your training zone for longer than 20 minutes.) Breathe regularly and deeply as you exercise—never hold your breath.

A Cool-down—Finish each workout with 5 to 10 minutes of stretching to cool down. This will increase the flexibility of your muscles and will help prevent post-exercise problems.

EXERCISE FREQUENCY

To maintain or improve your condition, complete three workouts each week, with at least one day of rest between workouts. After a few months, you may complete up to five workouts each week if desired. The key to success is to make exercise a regular and enjoyable part of your everyday life.

PART LIST—Model No. HRTL71706.0

R0906A

To locate the parts listed below, see the EXPLODED DRAWING on pages 24 to 27.

Key No.	Qty.	Description	Key No.	Qty.	Description
1	2	Foot Rail Decal	47	1	Front Roller
2	2	3/4" Screw	48	1	Walking Belt
3	25	Screw	49	1	Walking Platform
4	1	Reset/Off Circuit Breaker	50	1	Incline Motor/Controller Wire
5	10	Foot Rail Screw	51	1	Rear Roller
6	2	Isolator	52	1	Left Rear Endcap
7	7	Hood Screw/Isolator Screw	53	2	Rear Roller Bolt
8	8	Star Washer	54	1	Right Rear Endcap
9	2	Platform Bolt, Back	55	1	Hex Key
10	2	Platform Bolt, Front	56	1	Incline Stop Bracket
11	4	Belt Guide Screw	57	1	Base Ground Wire
12	2	Belt Guide	58	1	Frame
13	1	Power Cord Grommet	59	1	Belly Pan
14	2	Front Endcap Screw	60	4	U-nut
15	2	Frame Pivot Bolt	61	1	Reed Switch Clip
16	1	Left Foot Rail	62	2	Handrail Endcap
17	1	Right Foot Rail	63	1	Reed Switch
18	1	Motor Pivot Pin	64	4	Handrail Bolt
19	1	Motor Bracket	65	2	2 1/2" Extension Leg Bolt
20	1	Handrail	66	6	Star Washer
21	1	Latch Pin Assembly	67	2	Extension Leg Nut
22	2	Motor Washer	68	2	Caution Decal
23	1	Motor Star Washer	69	1	Warning Decal
24	2	Motor Bolt	70	2	Platform Nut
25	2	Motor Tension Bolt	71	10	Cable Tie
26	1	Motor Belt	72	1	Incline Motor Bolt
27	1	Drive Motor	73	1	Latch Housing
28	2	Rear Roller Washer	74	2	Tie Clamp
29	4	U-nut	75	1	Releasable Tie
30	2	Motor Nut	76	1	Access Door
31	2	Lift Frame Bolt	77	1	Wire Harness
32	6	Locknut	78	2	Extension Leg Endcap
33	14	Ground Screw	79	1	Key/Clip
34	1	Console	80	2	Front Wheel
35	2	Fan Screw	81	2	Wheel Pin
36	1	Power Cord	82	2	Base Pad
37	1	Console Fan	83	4	1" Tek Screw
38	1	Controller	84	1	Upright
39	1	Electronic Bracket	85	1	Console Base
40	1	Filter Wire	86	1	Incline Motor Bolt
41	1	Hood	87	1	Hairpin Cotter Pin
42	1	Front Roller Bushing	88	1	Incline Motor
43	1	Lift Frame	89	2	Extension Leg
44	2	Front Endcap	90	2	Rear Roller Bracket
45	1	Front Roller Bolt	91	2	Rear Roller Lock Washer
46	1	Magnet	92	2	2 1/4" Extension Leg Bolt

Key No.	Qty.	Description	Key No.	Qty.	Description
93	1	Optic Disk	104	1	Front Roller Nut
94	1	Photo Switch Nut	105	1	Large Belly Pan Screw
95	4	Hood Clip	106	3	Belly Pan Screw
96	1	Photo Switch	#	1	4" Blue Wire, 2F
97	1	Photo Switch Bolt	#	1	10" Red Wire, M/F
98	2	Dumbbell	#	1	12" Blue Wire, 2F
99	1	Latch Plate	#	1	8" Black Wire, M/F
100	4	Wire Tie	#	1	12" Blue Wire, M/F
101	1	Roller Ground Wire	#	1	User's Manual
102	1	Photo Switch Wire	"#" indicates a non-illustrated part.		
103	2	Extension Leg Base Bad	Specifications are subject to change without notice.		

ORDERING REPLACEMENT PARTS

To order replacement parts, see the front cover of this manual. To help us assist you, please be prepared to give the following information:

- the MODEL NUMBER of the product (HRTL71706.0)
- the NAME of the product (HEALTHRIDER PRO H500i treadmill)
- the SERIAL NUMBER of the product (see the front cover of this manual)
- the KEY NUMBER and DESCRIPTION of the part(s) (see pages 22 to 27)

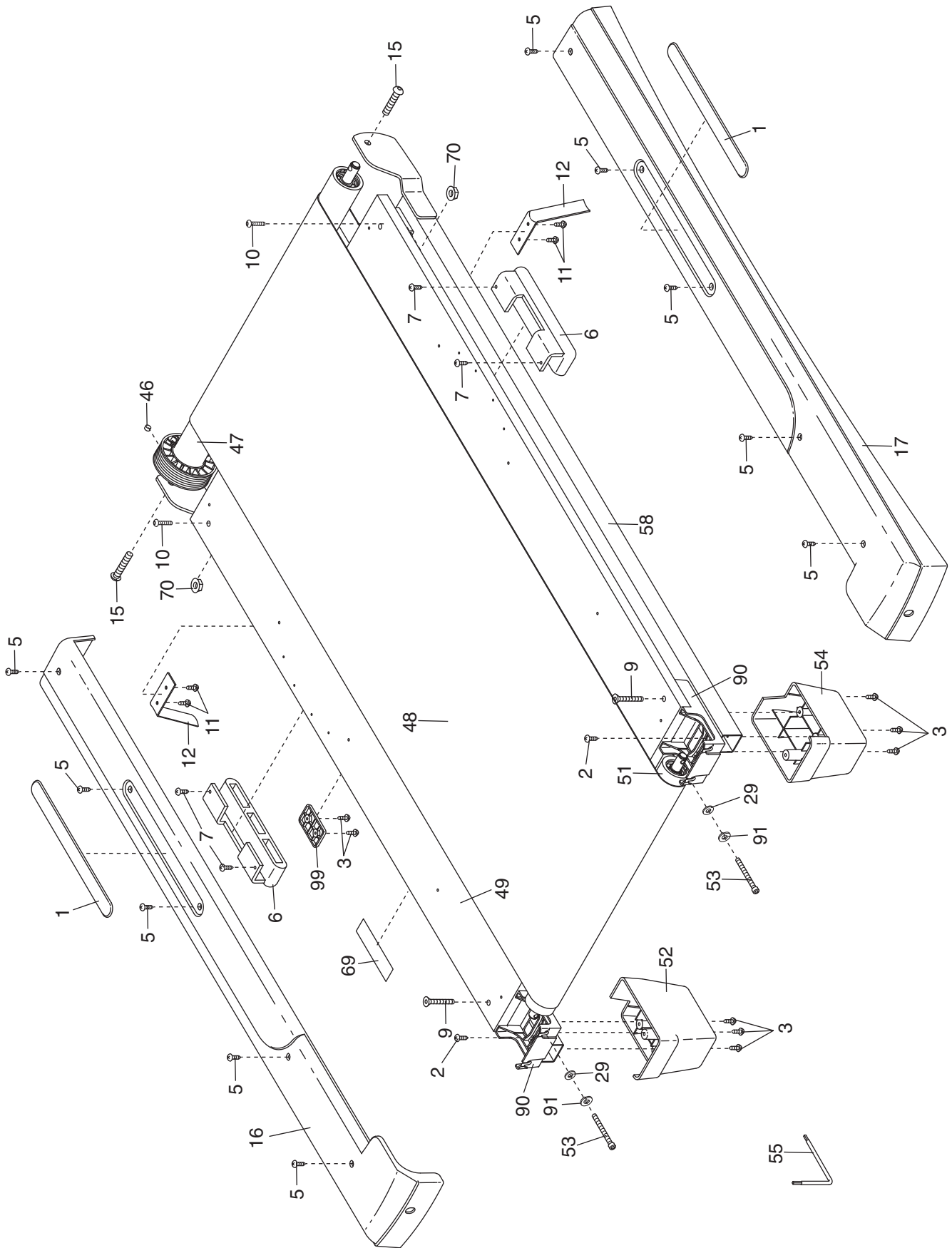

EXPLODED DRAWING C—Model No. HRTL71706.0

R0906A

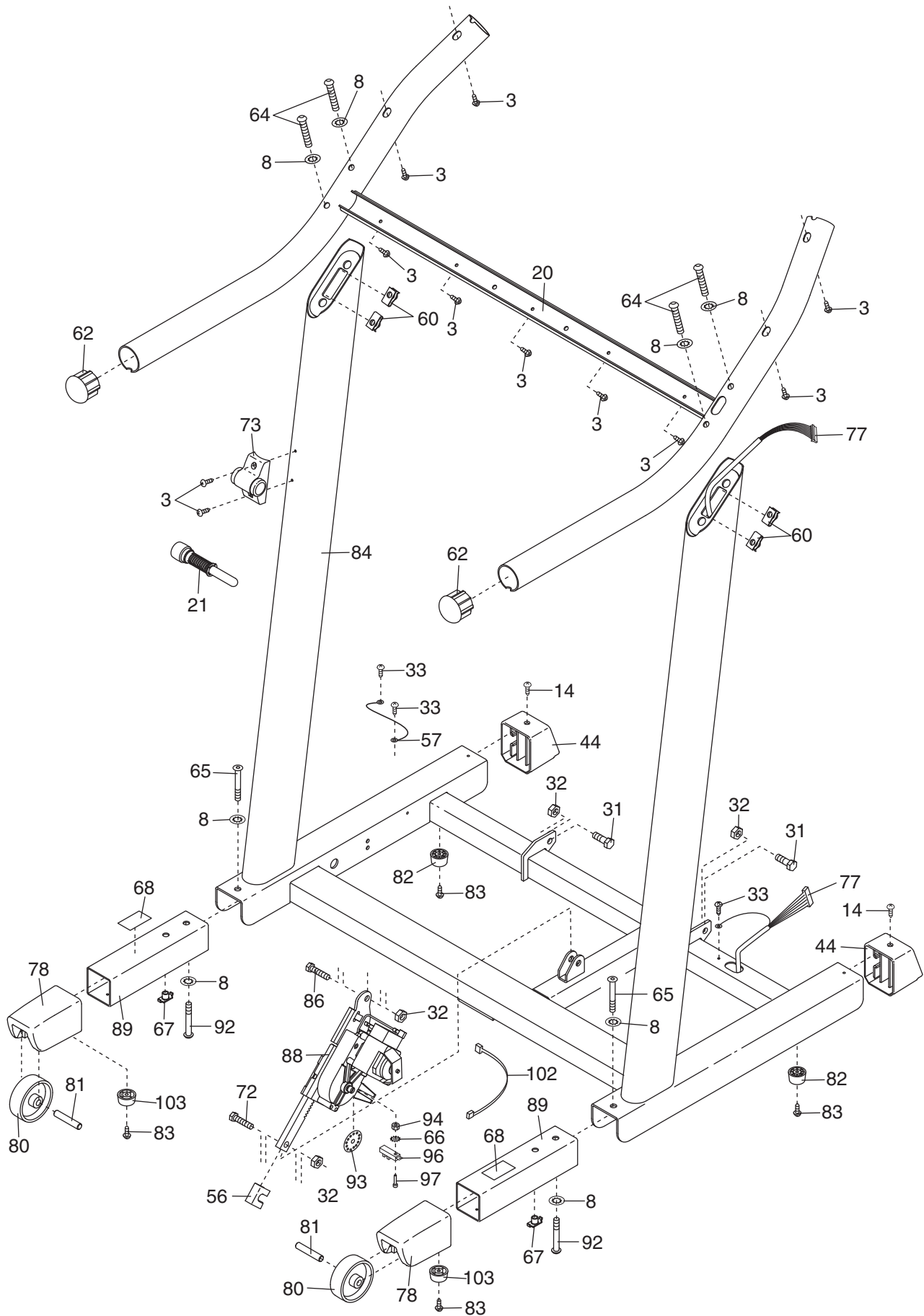

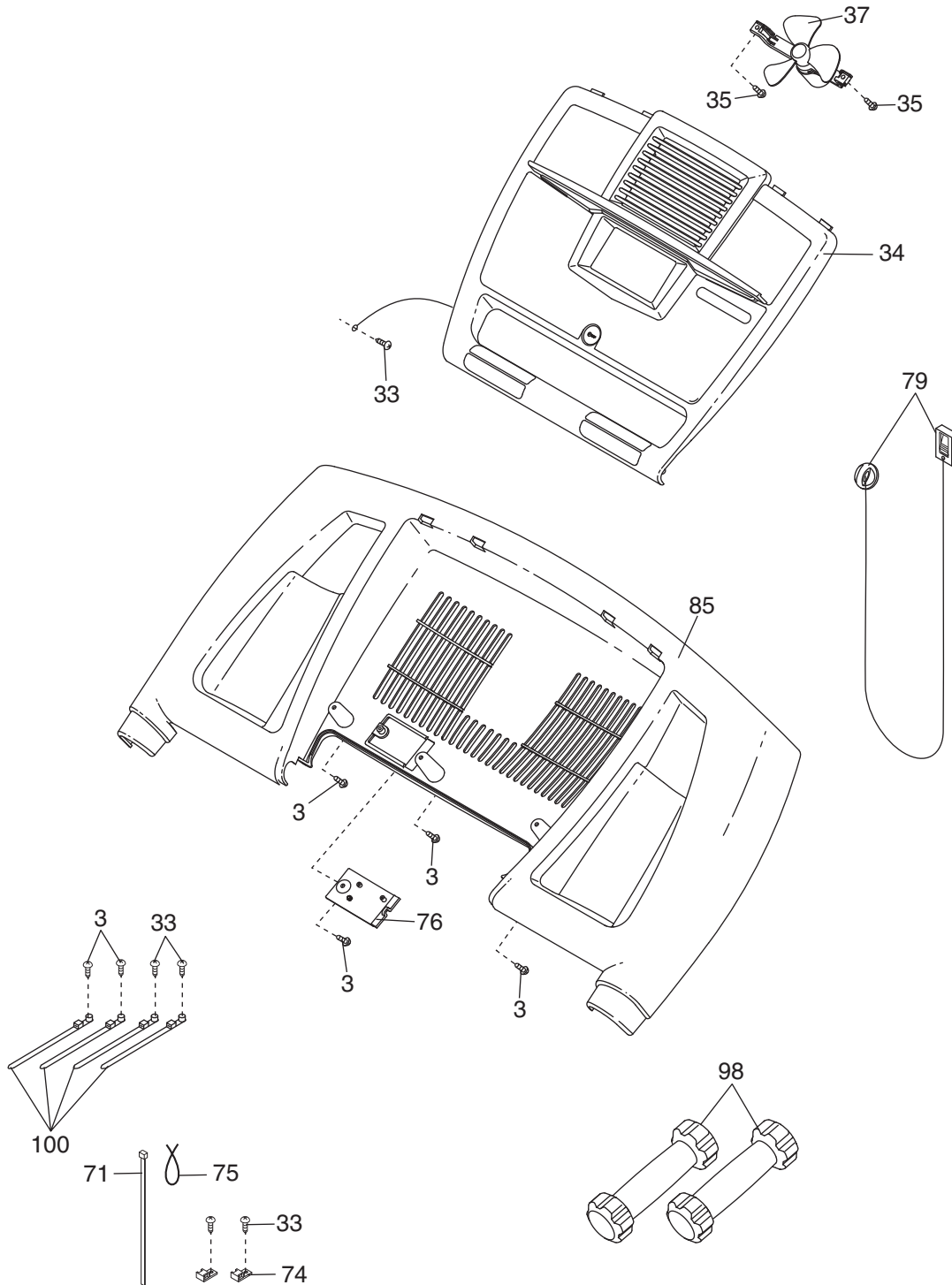

LIMITED WARRANTY

WHAT IS COVERED—The entire HealthRider H500i treadmill (“Product”) is warranted to be free of all defects in material and workmanship.

WHO IS COVERED—The original purchaser or any person receiving the Product as a gift from the original purchaser.

HOW LONG IS IT COVERED—ICON Health & Fitness, Inc. (“ICON”), warrants the drive motor for 10 years. Parts and labor are warranted for 1 year from the date of purchase.

WHAT WE DO TO CORRECT COVERED DEFECTS—We will ship to you, without charge, any replacement part or component, providing the repairs are authorized by ICON first and are performed by an ICON trained and authorized service provider, or, at our option, we will replace the Product.

WHAT IS NOT COVERED—Any failures or damage caused by unauthorized service, misuse, accident, negligence, improper assembly or installation, alterations, modifications without our written authorization or by failure on your part to use, operate, and maintain as set out in your User’s Manual (“Manual”). This warranty does not extend to products used for commercial or rental purposes.

WHAT YOU MUST DO—Always retain proof of purchase, such as your bill of sale; store, operate, and maintain the Product as specified in the Manual; notify our Customer Service Department of any defect within 10 days after discovery of the defect; as instructed, return any defected part for replacement or, if necessary, the entire product, for repair.

USER’S MANUAL—It is VERY IMPORTANT THAT YOU READ THE MANUAL before operating the Product. Remember to do the periodic maintenance requirements specified in the Manual to assure proper operation and your continued satisfaction.

HOW TO GET PARTS AND SERVICE—Simply call our Customer Service Department at 1-888-922-4222 and tell them your name and address and the serial number of your Product. They will tell you how to get a part replaced, or if necessary, arrange for service where your Product is located or advise you how to ship the Product for service. Before shipping, always obtain a Return Authorization Number (RA No.) from our Customer Service Department; securely pack your Product (save the original shipping carton if possible); put the RA No. on the outside of the carton and insure the product. Include a letter explaining the product or problem and a copy of your proof of purchase if you believe the service is covered by warranty.

ICON is not responsible or liable for indirect, special or consequential damages arising out of or in connection with the use or performance of the product or damages with respect to any economic loss, loss of property, loss of revenues or profits, loss of enjoyment or use, costs of removal, installation or other consequential damages of whatsoever nature. Some states do not allow the exclusion or limitation of incidental or consequential damages. Accordingly, the above limitation may not apply to you.

The warranty extended hereunder is in lieu of any and all other warranties and any implied warranties of merchantability or fitness for a particular purpose is limited in its scope and duration to the terms set forth herein. Some states do not allow limitations on how long an implied warranty lasts. Accordingly, the above limitation may not apply to you.

No one is authorized to change, modify or extend the terms of this limited warranty.

This warranty gives you specific legal rights and you may have other rights which vary from state to state.

ICON HEALTH & FITNESS, INC., 1500 S. 1000 W., LOGAN, UT 84321-9813

Free Manuals Download Website

<http://myh66.com>

<http://usermanuals.us>

<http://www.somanuals.com>

<http://www.4manuals.cc>

<http://www.manual-lib.com>

<http://www.404manual.com>

<http://www.luxmanual.com>

<http://aubethermostatmanual.com>

Golf course search by state

<http://golfingnear.com>

Email search by domain

<http://emailbydomain.com>

Auto manuals search

<http://auto.somanuals.com>

TV manuals search

<http://tv.somanuals.com>