

HEAT CONTROLLER, INC.

Comfort-Aire®

Through-The-Wall Air Conditioner

MODELS: BDE-103-A
BDE-123-A

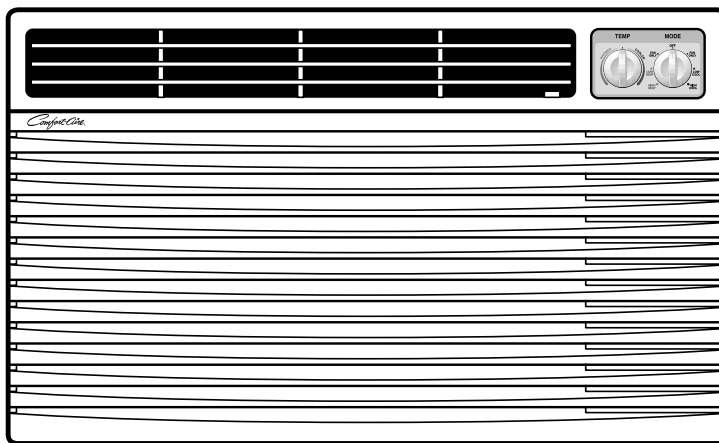

Service Manual

CAUTION

- Before servicing the unit, read the "safety precautions" in this manual.
- Only for authorized service personnel.

CONTENTS

1. PREFACE

1.1 SAFETY PRECAUTIONS	2
1.2 INSULATION RESISTANCE TEST.....	2
1.3 FEATURES	4
1.4 CONTROL LOCATIONS.....	4

2. DISASSEMBLY INSTRUCTIONS

2.1 MECHANICAL PARTS.....	6
2.1.1 FRONT GRILLE	6
2.1.2 CABINET.....	6
2.1.3 CONTROL BOX.....	6
2.2 AIR HANDLING PARTS.....	7
2.2.1 ORIFICE, HEATER ASSY AND TURBO FAN	7
2.2.2 FAN	7
2.2.3 SHROUD.....	8
2.3 ELECTRICAL PARTS	8
2.3.1 MOTOR.....	8
2.3.2 COMPRESSOR	8
2.3.3 CAPACITOR	8
2.3.4 POWER CORD	9
2.3.5 THERMOSTAT	9
2.3.6 ROTARY SWITCH.....	9

2.4 REFRIGERATION CYCLE.....	10
2.4.1 CONDENSER	10
2.4.2 EVAPORATOR	10
2.4.3 CAPILLARY TUBE.....	10

3. INSTALLATION

3.1 HOW TO INSTALL THE UNIT	13
3.2 INSTALLATION KITS CONTENTS.....	14
3.3 SUGGESTED TOOL REQUIREMENTS.....	15
3.3.1 PREPARATION OF SLEEVE	15
3.3.2 UNIT INSTALLATION	16

4. TROUBLESHOOTING GUIDE

4.1 OUTSIDE DIMENSIONS.....	17
4.2 PIPING SYSTEM	17
4.3 TROUBLESHOOTING GUIDE.....	18

5. SCHEMATIC DIAGRAM

5.1 CIRCUIT DIAGRAM.....	23
--------------------------	----

6. EXPLODED VIEW

7. REPLACEMENT PARTS LIST

1. PREFACE

This SERVICE MANUAL provides various service information, including the mechanical and electrical parts etc. This room air conditioner was manufactured and assembled under a strict quality control system. The refrigerant is charged at the factory. Be sure to read the safety precautions prior to servicing the unit.

1.1 SAFETY PRECAUTIONS

1. When servicing the unit, set the ROTARY SWITCH or POWER SWITCH to OFF(O) and unplug the power cord.
2. Observe the original lead dress.
If a short circuit is found, replace all parts which have been overheated or damaged by the short circuit.
3. After servicing the unit, make an insulation resistance test to protect the customer from being exposed to shock hazards.

1.2 INSULATION RESISTANCE TEST

1. Unplug the power cord and connect a jumper between 2 pins (black and white).
2. The grounding conductor (green or green & yellow) is to be open.
3. Measure the resistance value with an ohm meter between the jumpered lead and each exposed metallic part on the equipment at all the positions (except OFF or O) of the ROTARY SWITCH.
4. The value should be over 1MΩ.

1.3 SPECIFICATIONS

1.3.1 FOR BDE-103-A/BDE-123-A

ITEMS		MODELS	BDE-103-A	BDE-123-A	REMARK
POWER SUPPLY			1Ø, 208/ 230V, 60Hz		
COOLING	CAPACITY (Btu/h)		9,800/10,000	11,400/11,700	
	INPUT (W)		1,040/1,060	1,210/1,250	
	RUNNING CURRENT (A)		5.2/4.7	6.2/5.8	
	E.E.R. (Btu/W.h)		9.4	9.4	
HEATING	CAPACITY (Btu/h)		9,200/11,200		
	INPUT (W)		2,900/3,500		
	RUNNING CURRENT (A)		14.0/15.3		
OPERATING TEMPERATURE	COOLING	INDOOR (°C)	26.7 (DB)	19.4 (WB)	
		OUTDOOR (°C)	35 (DB)	23.9 (WB)	
	HEATING	INDOOR (°C)	21.1 (DB)	15.6 (WB)	
		OUTDOOR (°C)	8.3 (DB)	6.1 (WB)	
REFRIGERANT (R-22) CHARGE(g)			440(15.5 OZ)	470(16.6 OZ)	
EVAPORATOR			2 ROW 12 STACKS	3 ROW 12 STACKS	LOUVERED-FIN TYPE
CONDENSER			2 ROW 17 STACKS, L-BENDED TYPE		
FAN, INDOOR			TURBO FAN		
FAN, OUTDOOR			PROPELLER TYPE FAN WITH SLINGER-RING		
FAN SPEEDS (FAN/COOLING/HEATING)			1/ 2/ 2		
FAN MOTOR			6 POLES		
OPERATION CONTROL			ROTARY SWITCH		
ROOM TEMP. CONTROL			THERMOSTAT		
AIR DIRECTION CONTROL			VERTICAL LOUVER (RIGHT & LEFT)		
			HORIZONTAL LOUVER (UP & DOWN)		
CONSTRUCTION			TOP-DOWN		
ELECTRIC HEATER			3.5KW, 230V		
PROTECTOR	COMPRESSOR		EXTERNAL OVERLOAD PROTECTOR		
	FAN MOTOR		INTERANL THERMAL PROTECTOR		
	ELECTRIC HEATER		FUZE LINK, BIMETAL THERMOSTAT		
POWER CORD			1.6m (3 WIRE WITH GROUDING)		
			ATTACHMENT PLUG (CORD-CONNECTED TYPE)		
DRAIN SYSTEM			SPLASHED BY FAN SLINGER		
NET WEIGHT (lbs/kg)			80/36	81/37	
DIMENSION (W x H x D)		(inch)	24 ^{21/32} x 14 ^{13/32} x 19 ^{21/32}		
		(mm)	626 x 366 x 499		
SLEEVE DIMESION (W x H x D)		(inch)	25 ^{7/8} x 15 ^{17/32} x 16 ^{23/32}		OPTIONAL PART
		(mm)	656 x 394 x 425		
SLEEVE DEPTH WITH FRONT GRILLE		(inch)	20		
		(mm)	510		

1.4 FEATURES

- Designed for cooling only.
- Powerful and quiet cooling.
- Top-down chassis for the simple installation and service.
- Side air-intake, side cooled-air discharge.
- Built in adjustable THERMOSTAT.
- Washable one-touch filter.
- Compact size.

1.5 CONTROL LOCATIONS

1.5.1 COOLING ONLY MODEL

• OPERATION

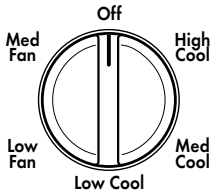
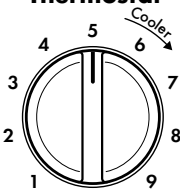
<p>Operation</p> 	<p>Off - Turns air conditioner off. Med Fan - Med speed fan operation without cooling. Low Fan - Low speed fan operation without cooling. High Cool - Cooling with high speed fan operation. Med Cool - Cooling with med speed fan operation. Low Cool - Cooling with low speed fan operation.</p>
<p>Thermostat</p> 	<p>This automatically controls the temperature of the indoor air. Turn the knob so that arrow points to the larger marks for greater cooling. Point the arrow to the smaller marks for more moderate cooling. (i.e. the higher number, the greater cooling)</p>

• VENTILATION

The ventilation lever is located in the right of the air discharge.

The ventilation lever must be in the CLOSE position in order to maintain the best cooling conditions.

When fresh air is necessary in the room, set the ventilation lever to the OPEN position.

The damper is opened and room air is exhausted outside.

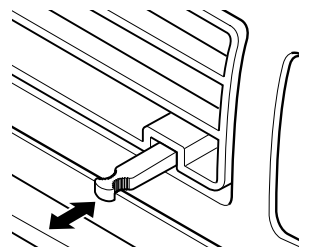

PULL OPEN / PUSH CLOSE

• ENERGY SAVER (optional)

On : Both the fan and the compressor turn on and turn off together while operation knob is set to the Cool position.

You can get the more economical operation.

Off : The fan runs constantly while operation knob is set to the Cool position.

You can access the Energy Saver switch when you open the inlet grille.

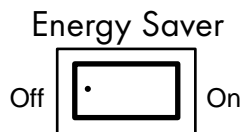

1.5.2 COOLING AND HEATING MODEL

• OPERATION

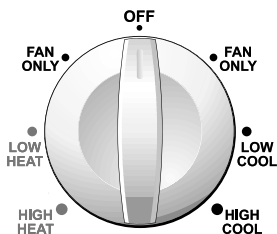
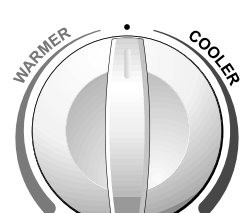
<p>MODE</p> 	<p>OFF - Turns the air conditioner off. FAN ONLY - The low fan speed operation without cooling/heating. LOW COOL - Cooling with the low speed fan operation. HIGH COOL - Cooling with the high speed fan operation. LOW HEAT - Heating with the low speed fan operation. HIGH HEAT - Heating with the high speed fan operation.</p>
<p>TEMP</p> 	<p>Turn the Temperature Knob to the desired setting. The central position is a normal setting for average conditions. You can change this setting, if necessary, in accordance with your temperature preference.</p> <p>The thermostat automatically controls cooling or heating, but the fan runs continuously whenever the air conditioner is in operation. If the room is too warm, turn the thermostat control clockwise. If the room is too cool, turn the thermostat control counterclockwise.</p>

CAUTION

When the air conditioner has been performed its cooling or heating operation and is turned off or set to the fan position, wait at least 3 minutes before resetting to the cooling operation again.

• HEAT PUMP MODELS

When the outdoor temperature is lower than -4°C (24°F), the electric heater will turn on instead of the heat pump.

A slight heat odor may come from the unit when first switching to HEAT after the cooling season is over. This odor, caused by fine dust particles on the heater, will disappear quickly.

2. DISASSEMBLY INSTRUCTIONS

— Before the following disassembly, POWER SWITCH is set to OFF and disconnected the power cord.

2.1 MECHANICAL PARTS

2.1.1 FRONT GRILLE

1. Open the inlet grille upward or downward.
2. Remove the screw which fastens the front grille.
3. Pull the front grille from the right side.
4. Remove the front grille. (See Fig. 1)
5. Re-install the component by referring to the removal procedure.

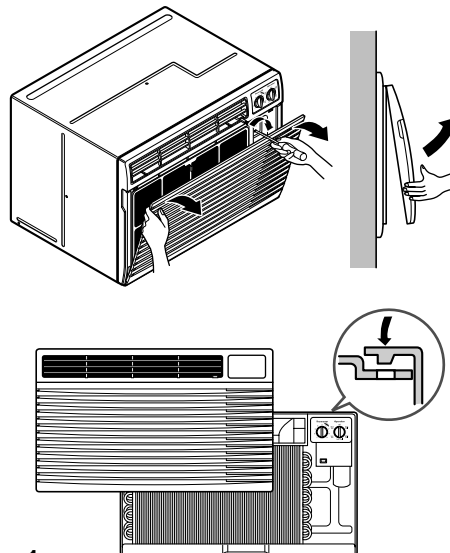

Figure 1

2.1.2 CABINET

1. After disassembling the FRONT GRILLE, remove the 9 screws which fasten the cabinet at the both sides and the top. (See Fig. 2)
Keep these for later use.

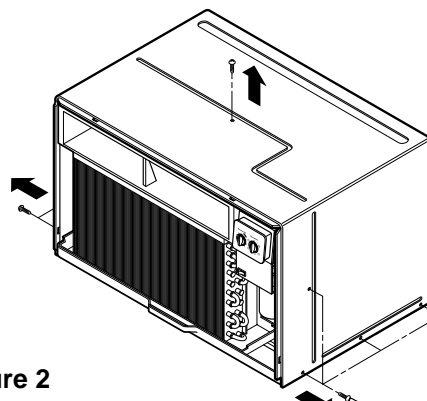

Figure 2

2.1.3 CONTROL BOX

1. Remove the front grille. (Refer to section 2.1.1)
2. Remove the screw which fasten the control box. (See Fig. 3)
3. Pull the control box from the barrier. (See Fig. 3)
4. Discharge the capacitor by placing a 20,000 ohm resistor across the capacitor terminals.
5. Disconnect two wire housings in the control box.
6. Pull the control box forward completely.
7. Re-install the components by referring to the removal procedure. (See Fig. 3)
(Refer to the circuit diagram found on pages 26~27 in this manual and on the control box.)

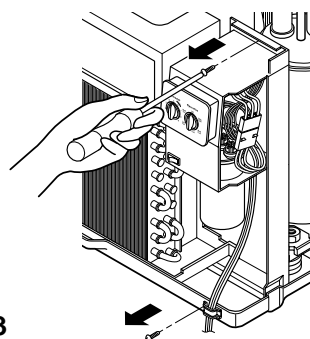

Figure 3

2.2 AIR HANDLING PARTS

2.2.1 ORIFICE, HEATER ASSY AND TURBO FAN

1. Remove the front grille. (Refer to section 2.1.1)
2. Remove the cabinet. (Refer to section 2.1.2)
3. Remove the 2 screws which fasten the evaporator at the left side and the right side. (See Fig. 4)
4. Move the evaporator sideward carefully.
5. Remove the 2 terminals carefully (See Fig. 5, at Electric Heater Model only)
6. Remove the 4 screws which fasten the orifice. (See Fig. 5)
7. Remove the orifice. (See Fig. 5)

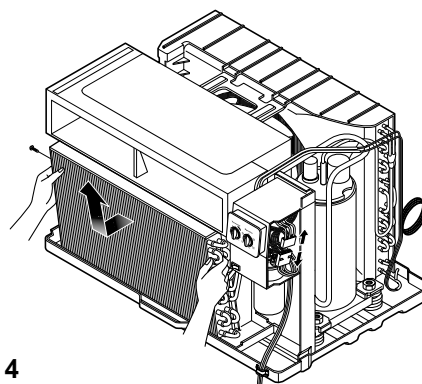

Figure 4

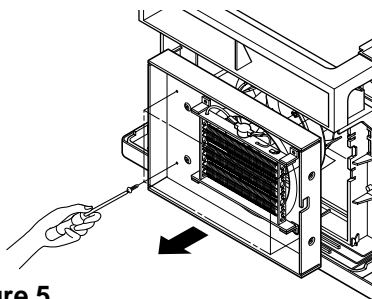

Figure 5

8. Remove the clamp which secures the turbo fan with plier. (See Fig. 6)

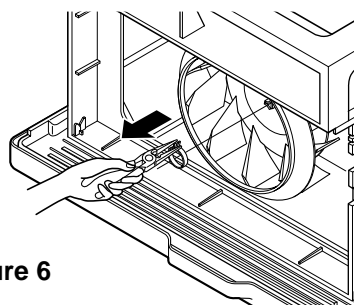

Figure 6

9. Remove the turbo fan with plier or your hand without touching blades. (See Fig. 7)
10. Re-install the components by referring to the removal procedure, above.

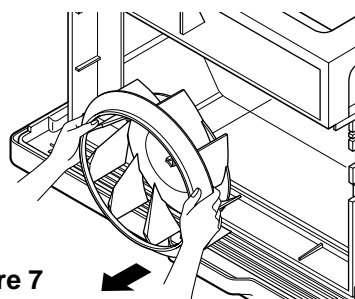

Figure 7

2.2.2 FAN

1. Remove the cabinet. (Refer to section 2.1.2)
2. Remove the brace and shroud cover. (Refer to section 2.2.1)
3. Remove the 6 screws which fasten the condenser.
4. Move the condenser sideways carefully.
5. Remove the clamp which secures the fan.
6. Remove the fan. (See Fig. 8)
7. Re-install the components by referring to the removal procedure, above.

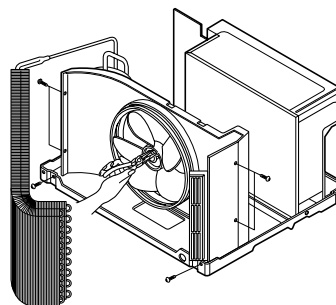

Figure 8

2.2.3 SHROUD

1. Remove the fan. (Refer to section 2.2.2)
2. Remove the screw which fasten the shroud.
3. Remove the shroud. (See Fig. 9)
4. Re-install the component by referring to the removal procedure, above.

2.3 ELECTRICAL PARTS

2.3.1 MOTOR

1. Remove the cabinet. (Refer to section 2.1.2)
2. Remove the clamp cord and disconnect a wire housing in control box. (Refer to section 2.1.3)
3. Remove the turbo fan. (Refer to section 2.2.2)
4. Remove the fan. (Refer to section 2.2.2)
5. Remove the 4 or 2 screws which fasten the motor. (See Fig. 10)
6. Remove the motor.
7. Re-install the components by referring to the removal procedure, above.

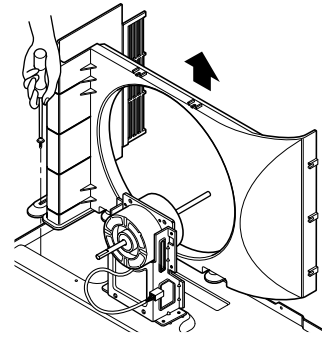

Figure 9

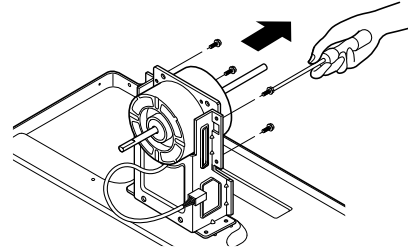

Figure 10

2.3.2 COMPRESSOR

1. Remove the cabinet. (Refer to section 2.1.2)
2. Discharge the refrigerant system using Freon™ Recovery System.
If there is no valve to attach the recovery system, install one (such as a WATCO A-1) before venting the Freon™. Leave the valve in place after servicing the system.
3. Disconnect the 3 leads from the compressor.
4. After purging the unit completely, unbraid the suction and discharge tubes at the compressor connections.
5. Remove the 3 nuts and the 3 washers which fasten the compressor. (See Fig. 11)
6. Remove the compressor.
7. Re-install the components by referring to the removal procedure, above.

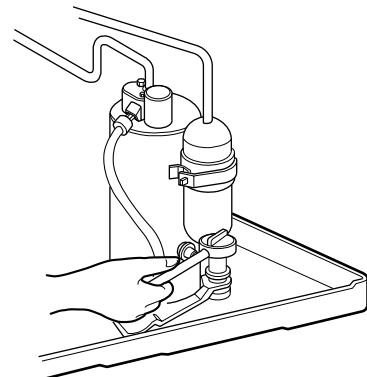

Figure 11

2.3.3 CAPACITOR

1. Remove the control box. (Refer to section 2.1.3)
2. Remove knobs and the tips which fasten the display panel.
3. Disconnect the 2 leads from the rocker switch and remove the panel (Energy saver model only).
4. Remove 2 screws and unfold the control box. (See Fig. 12)
5. Remove the Rotary Switch.
6. Remove the screw and the clamp which fastens the capacitor. (See Fig. 12)
7. Disconnect all the leads of capacitor terminals.
8. Re-install the components by referring to the removal procedure, above.

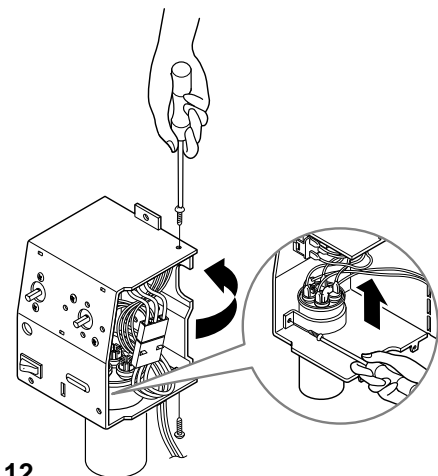

Figure 12

2.3.4 POWER CORD

1. Remove the control box. (Refer to section 2.1.3)
2. Unfold the control box. (Refer to section 2.3.3)
3. Disconnect the grounding screw from the control box.
4. Disconnect 2 receptacles.
5. Remove a screw which fastens the clip cord.
6. Pull the power cord. (See Fig. 13)
7. Re-install the component by referring to the removal procedure, above.
(Use only one ground-marked hole \oplus for ground connection.)
8. If the supply cord of this appliance is damaged, it must be replaced by the special cord.
(The special cord means the cord which has the same specification marked on the supply cord fitted to the unit.)

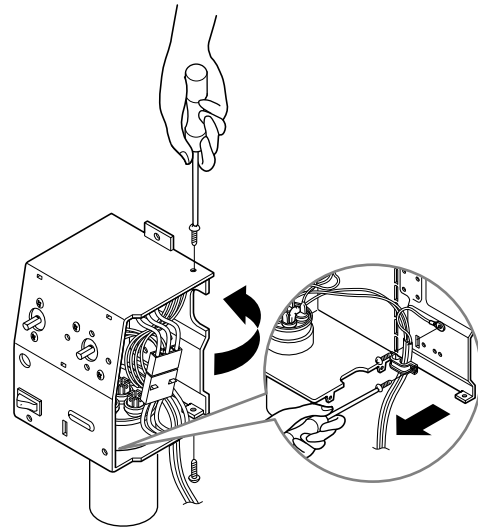

Figure 13

2.3.5 THERMOSTAT

1. Remove the control box. (Refer to section 2.1.3)
2. Unfold the control box. (Refer to section 2.3.3)
3. Remove the 2 screws which fasten the thermostat.
4. Disconnect all the leads of thermostat terminals.
5. Remove the thermostat. (See Fig. 14)
6. Re-install the components by referring to the removal procedure, above.

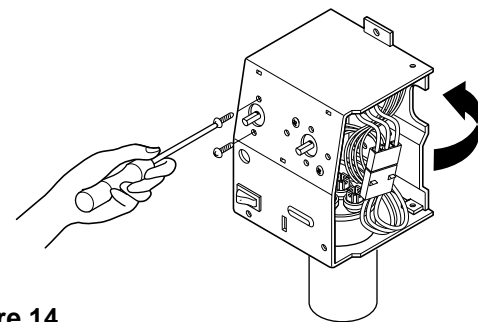

Figure 14

2.3.6 ROTARY SWITCH

1. Remove the control box. (Refer to section 2.1.3)
2. Unfold the control box. (Refer to section 2.3.3)
3. Remove 2 screws which fasten the rotary switch.
4. Disconnect all the leads of the rotary switch terminals.
5. Remove the rotary switch. (See Fig. 15)
6. Re-install the components by referring to the above removal procedure, above.

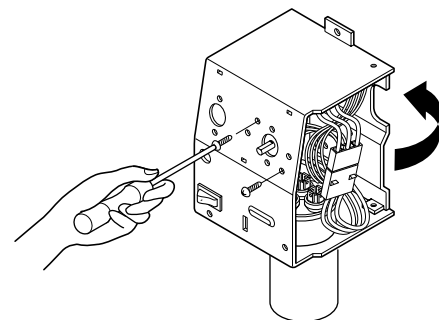

Figure 15

2.4 REFRIGERATION CYCLE

CAUTION

Discharge the refrigerant system using Freon™ Recovery System.
If there is no valve to attach the recovery system, install one (such as a WATCO A-1) before venting the Freon™. Leave the valve in place after servicing the system.

2.4.1 CONDENSER

1. Remove the cabinet. (Refer to section 2.1.2)
2. Remove the brace and the shroud cover. (Refer to section 2.2.1)
3. Remove the 5 screws which fasten the condenser.
4. After discharging the refrigerant completely, unbraid the interconnecting tube at the condenser connections.
5. Remove the condenser.
6. Re-install the components by referring to notes. (See Fig. 16)

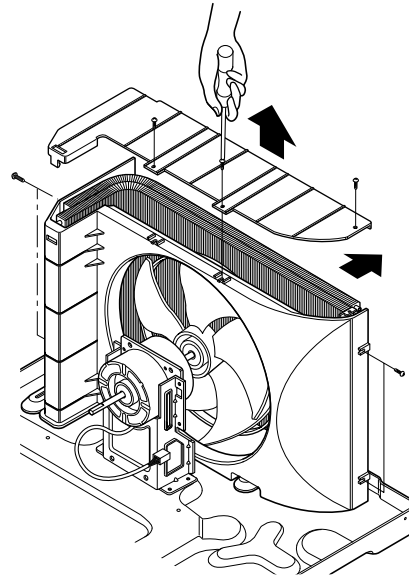

Figure 16

2.4.2 EVAPORATOR

1. Remove the cabinet. (Refer to section 2.1.2)
2. Discharge the refrigerant completely.
3. Remove the 2 screws which fasten the evaporator at the left side and the right side.
4. Move the evaporator sideward carefully and then unbraid the interconnecting tube at the evaporator connectors.
5. Remove the evaporator.
6. Re-install the components by referring to notes. (See Fig. 17)

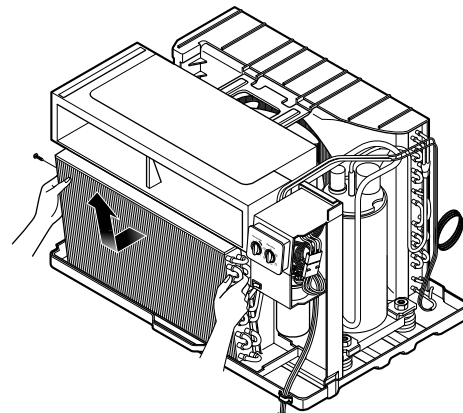

Figure 17

2.4.3 CAPILLARY TUBE

1. Remove the cabinet. (Refer to section 2.1.2)
2. After discharging the refrigerant completely, unbraid the interconnecting tube at the capillary tube.
3. Remove the capillary tube.
4. Re-install the components by referring to notes.

NOTES

— Replacement of the refrigeration cycle.

1. When replacing the refrigeration cycle, be sure to discharge the refrigerant system using a Freon™ recovery System.
If there is no valve to attach the recovery system, install one (such as a WATCO A-1) before venting the Freon™. Leave the valve in place after servicing the system.
2. After discharging the unit completely, remove the desired component, and unbrace the pinch-off tubes.
3. Solder service valves into the pinch-off tube ports, leaving the valves open.
4. Solder the pinch-off tubes with Service valves.
5. Evacuate as follows.
 - 1) Connect the vacuum pump, as illustrated Fig. 18A.
 - 2) Start the vacuum pump, slowly open manifold valves A and B with two full turns counterclockwise and leave the valves closed. The vacuum pump is now pulling through valves A and B up to valve C by means of the manifold and entire system.

CAUTION

If high vacuum equipment is used, just crack valves A and B for a few minutes, then open slowly with the two full turns counterclockwise. This will keep oil from foaming and being drawn into the vacuum pump.

- 3) Operate the vacuum pump for 20 to 30 minutes, until 600 microns of vacuum is obtained. Close valves A and B, and observe vacuum gauge for a few minutes. A rise in pressure would indicate a possible leak or moisture remaining in the system. With valves A and B closed, stop the vacuum pump.
- 4) Remove the hose from the vacuum pump and place it on the charging cylinder. See Fig. 18B. Open valve C.
Discharge the line at the manifold connection.
- 5) The system is now ready for final charging.

6. Recharge as follows :

- 1) Refrigeration cycle systems are charged from the High-side. If the total charge cannot be put in the High-side, the balance will be put in the suction line through the access valve which you installed as the system was opened.
- 2) Connect the charging cylinder as shown in Fig. 18B. With valve C open, discharge the hose at the manifold connection.
- 3) Open valve A and allow the proper charge to enter the system. Valve B is still closed.
- 4) If more charge is required, the high-side will not take it. Close valve A.
- 5) With the unit running, open valve B and add the balance of the charge.
 - a. Do not add the liquid refrigerant to the Low-side.
 - b. Watch the Low-side gauge; allow pressure to rise to 30 lbs.
 - c. Turn off valve B and allow pressure to drop.
 - d. Repeat steps B and C until the balance of the charge is in the system.
- 6) When satisfied the unit is operating correctly, use the pinch-off tool with the unit still running and clamp on to the pinch-off tube. Using a tube cutter, cut the pinch-off tube about 2 inches from the pinch-off tool. Use sil-fos solder and solder pinch-off tube closed. Turn off the unit, allow it to set for a while, and then test the leakage of the pinch-off connection.

Equipment needed: Vacuum pump, Charging cylinder, Manifold gauge, Brazing equipment. Pinch-off tool capable of making a vapor-proof seal, Leak detector, Tubing cutter, Hand Tools to remove components, Service valve.

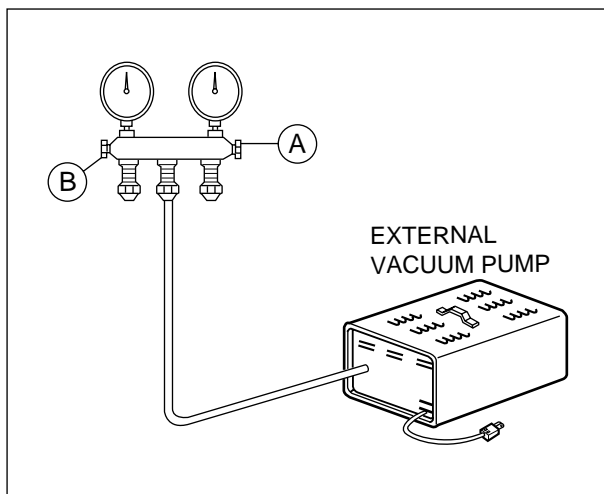
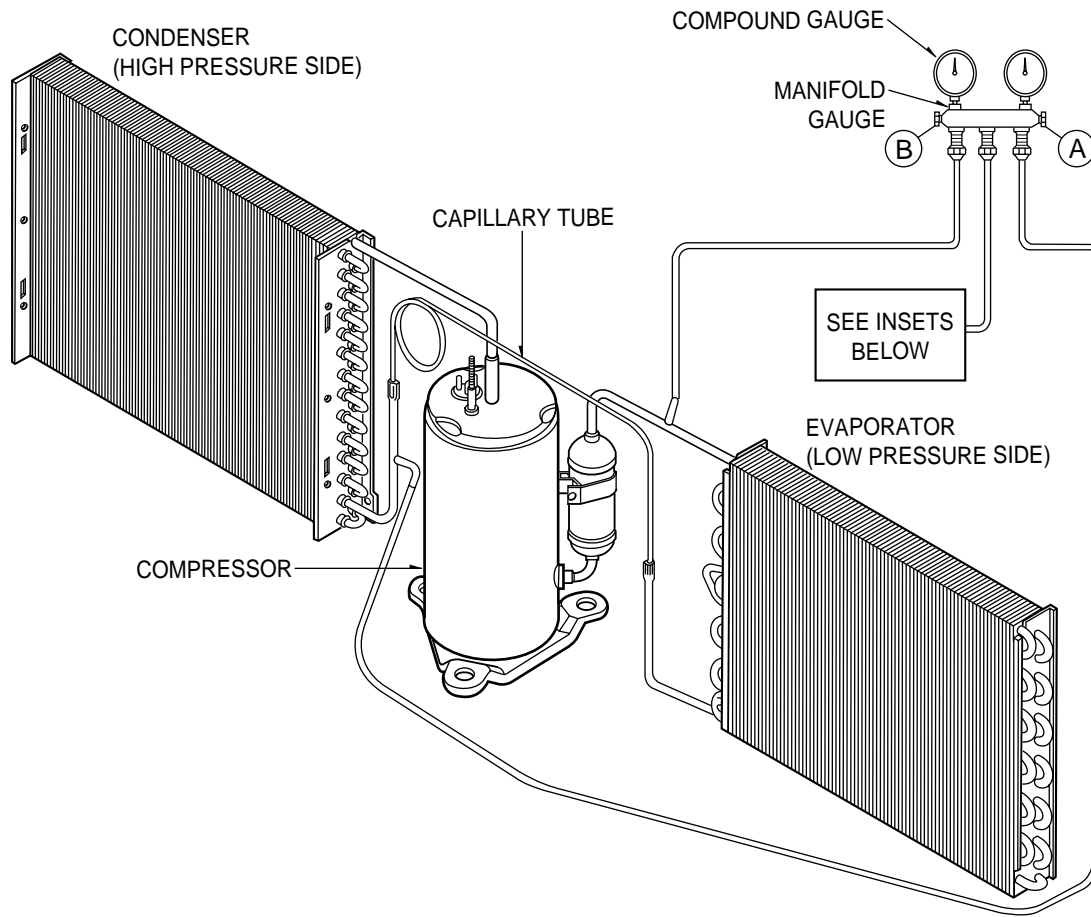

Figure 18A-Pulling Vacuum

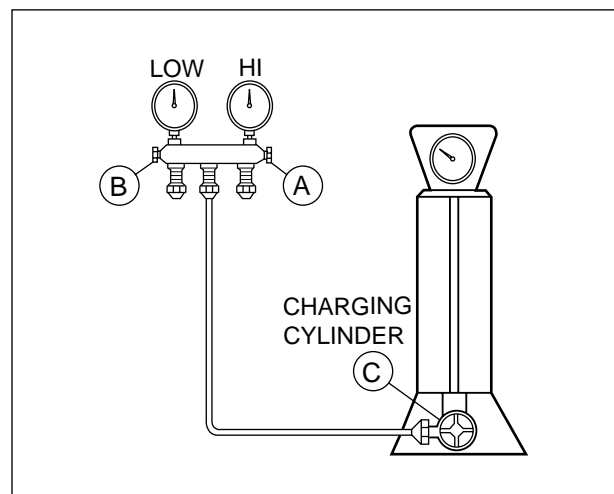

Figure 18B-Charging

3. INSTALLATION

3.1 HOW TO INSTALL THE UNIT

CAUTION

- There are sharp edges that can cause serious cuts.
- When lifting the air conditioner, it is HEAVY.
Use 2 peoples to lift.

For existing sleeve, you should measure the wall sleeve dimensions.

You can install the new air conditioner according to these installation instructions to achieve the best performance. All wall sleeves used to mount the new air conditioner must be in good structural condition and have the rear grille that securely attaches to the sleeve or the flange of the sleeve to secure the new air conditioner.

- To avoid vibration and noise, make sure the unit is installed securely and firmly.

Dimension of air conditioner

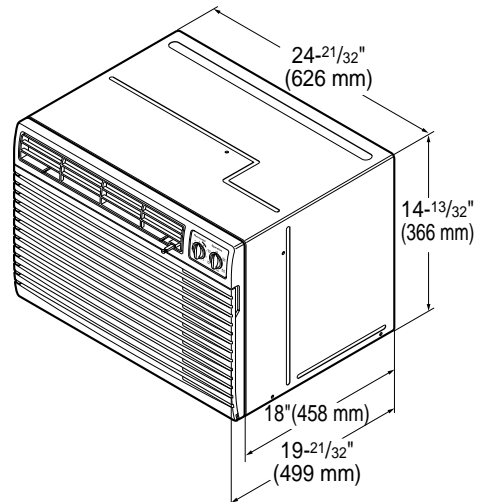

Dimension of sleeve assembly (optional)

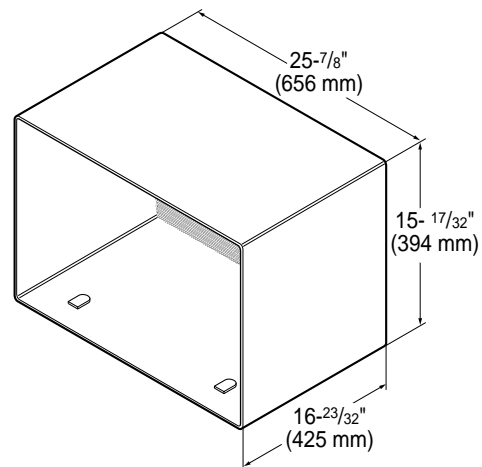

A. BEFORE ATTACHING THE FRONT GRILLE TO THE CABINET, IF YOU WANT TO PULL OUT THE FILTER UPWARD;

1. There should be no obstacle, like a fence, within 20" which might restrict heat radiation from the condenser.
2. To prevent reducing performance, install the unit so that louvers of the cabinet are not blocked.

B. IF YOU WANT TO PULL OUT THE FILTER DOWNWARD;

The grille is already designed for that way.

1. Install the unit a little obliquely outward not to leak the condensed water into the room (about 1/2" or 1/4" bubble with level).
2. Install the unit with its bottom portion 30~60" above the floor level.
3. The power cord must be connected to an independent circuit. The green wire must be grounded.

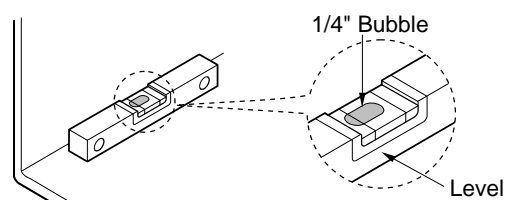
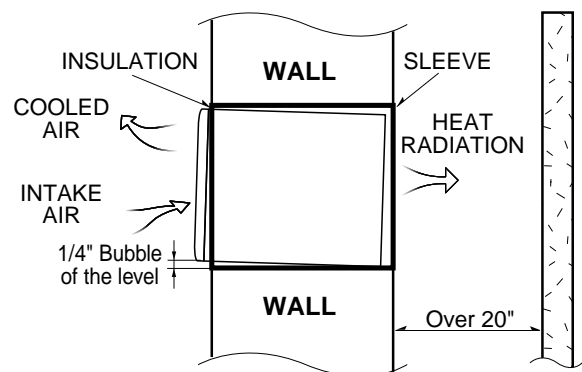

3.2 INSTALLATION KITS CONTENTS

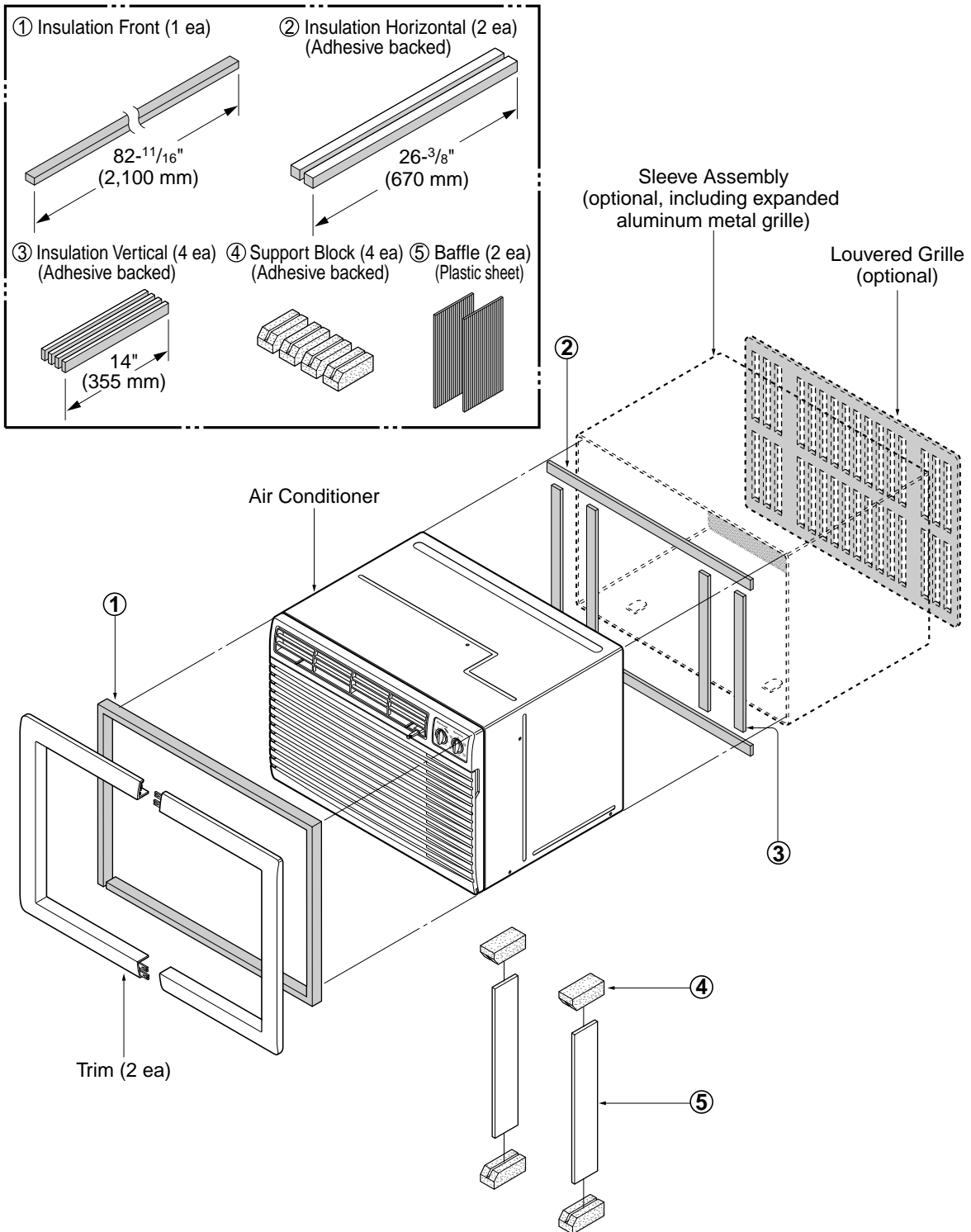

3.3 SUGGESTED TOOL REQUIREMENTS

SCREWDRIVER(+, -), RULER, KNIFE, HAMMER, PENCIL, LEVEL

3.3.1 PREPARATION OF SLEEVE

1. Remove the old air conditioner from the wall sleeve and prepare the wall sleeve.
Clean the interior of the sleeve (do not disturb the insulation or seals).
The wall sleeve must be fastened in the wall securely before installing the new air conditioner.
2. Prepare the wall sleeve for installation of the new unit according to the following installation procedures. Before you prepare the wall sleeve, you should check the wall sleeve dimensions.
3. Redirect the louvers at the back of the wall sleeves as following **A** and **B** lengths in the below table.

Width of the existing wall sleeve	A	B
25-1/2" (648 mm)	2-3/4" (70 mm)	4-3/4" (120 mm)
25-3/4" (654 mm)	2-3/4" (70 mm)	5" (130 mm)
26" (660 mm)	3" (75 mm)	5" (130 mm)
26-3/4" (680 mm)	3-1/4" (80 mm)	5-1/2" (140 mm)
27" (686 mm)	3-1/2" (90 mm)	5-1/2" (140 mm)

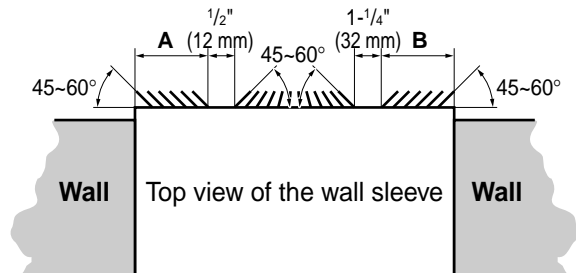

4. Sleeve (up to 18 inches deep)

When the depth of your existing sleeve is deeper than 18", please skip to step 5.
Remove the backing from horizontal insulation and attach them to the inside of the wall sleeve as shown below.

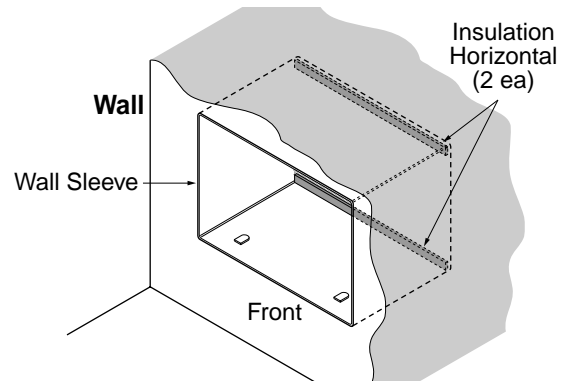

Remove the backing from insulation vertical and attach them to the inside of the wall sleeve, as shown below.

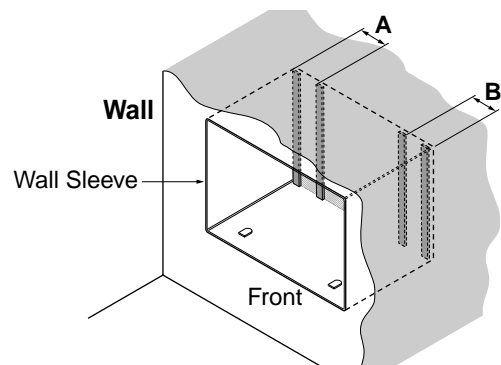

5. Sleeve (18-22 inches deep)

When the depth of your existing sleeve is not deeper than 18", please skip to step 6.
Cut the baffles and the support blocks as following **C** length in the below table.

Depth of the existing wall sleeve	C	
18-5/8" (473 mm)	3/4" (20 mm)	Support Block
19-3/4" (502 mm)	1-3/4" (45 mm)	Baffle
22" (559 mm)	4" (100 mm)	

Remove the backing from vertical and horizontal insulation and attach them to the inside of the wall sleeve as shown below. Remove the backing from the support blocks and attach them to the inside of the wall sleeve as shown below. Slide the baffles in the slots of the support blocks.

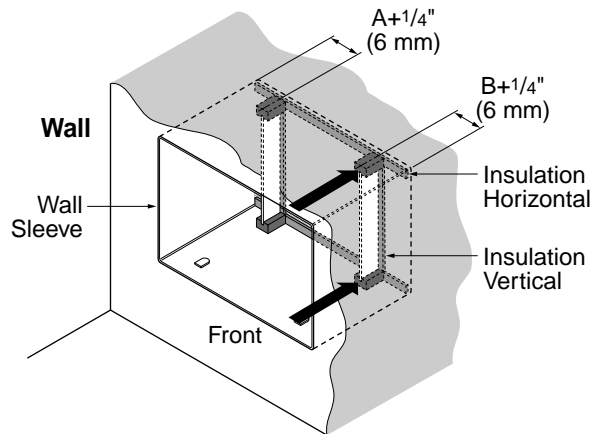

3.3.2 UNIT INSTALLATION

1. Remove the backing from vertical insulation and attach them to the back of the unit as shown below.

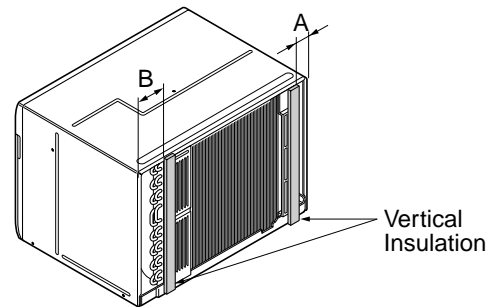

2. Install the new unit into the wall sleeve.
3. Insert front insulation between the wall sleeve and the unit. A flat-bladed screwdriver or putty knife is recommended.

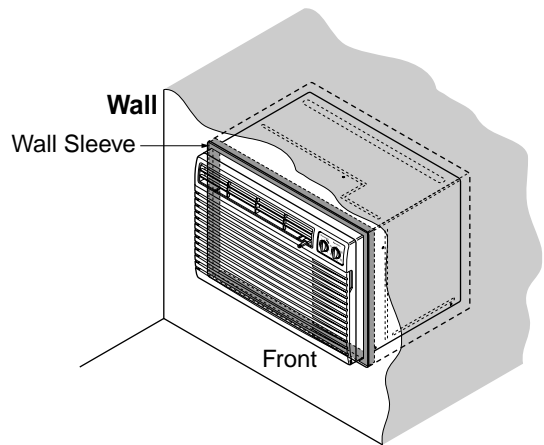

4. To assemble trim, insert the snaps into the slots of others. To install trim to the sleeve, slide the trim through the unit until it is flush with the wall sleeve.

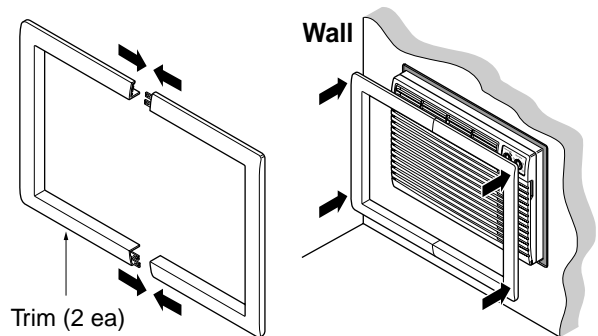

4. TROUBLESHOOTING GUIDE

4.1 OUTSIDE DIMENSIONS

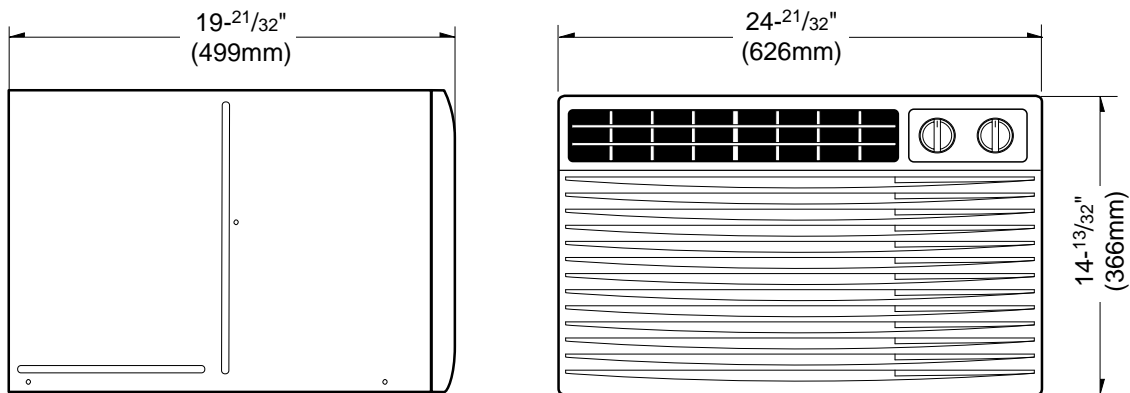

4.2 PIPING SYSTEM

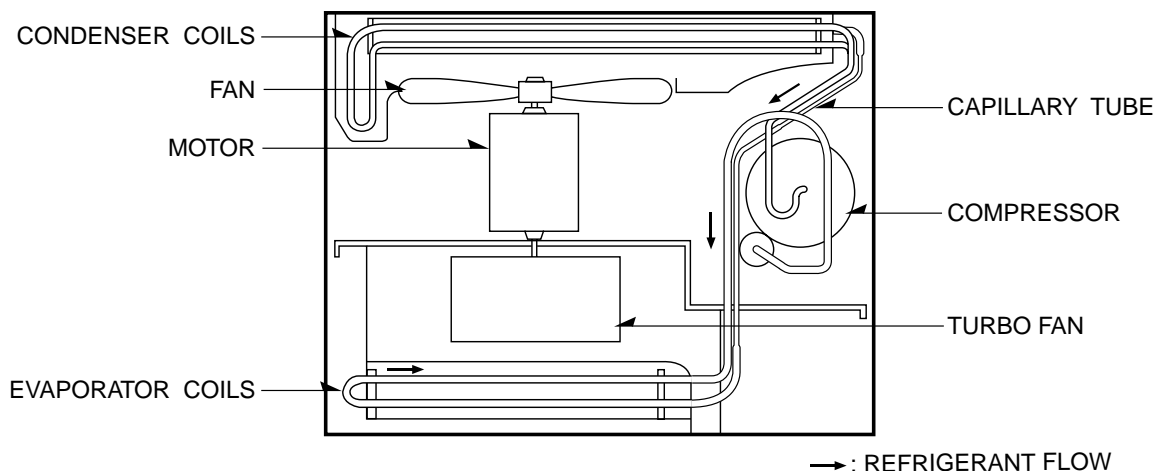

Following is a brief description of the important components and their functions in the refrigeration system. Refer to Fig. 19 to follow the refrigeration cycle and the flow of the refrigerant in the cooling cycle.

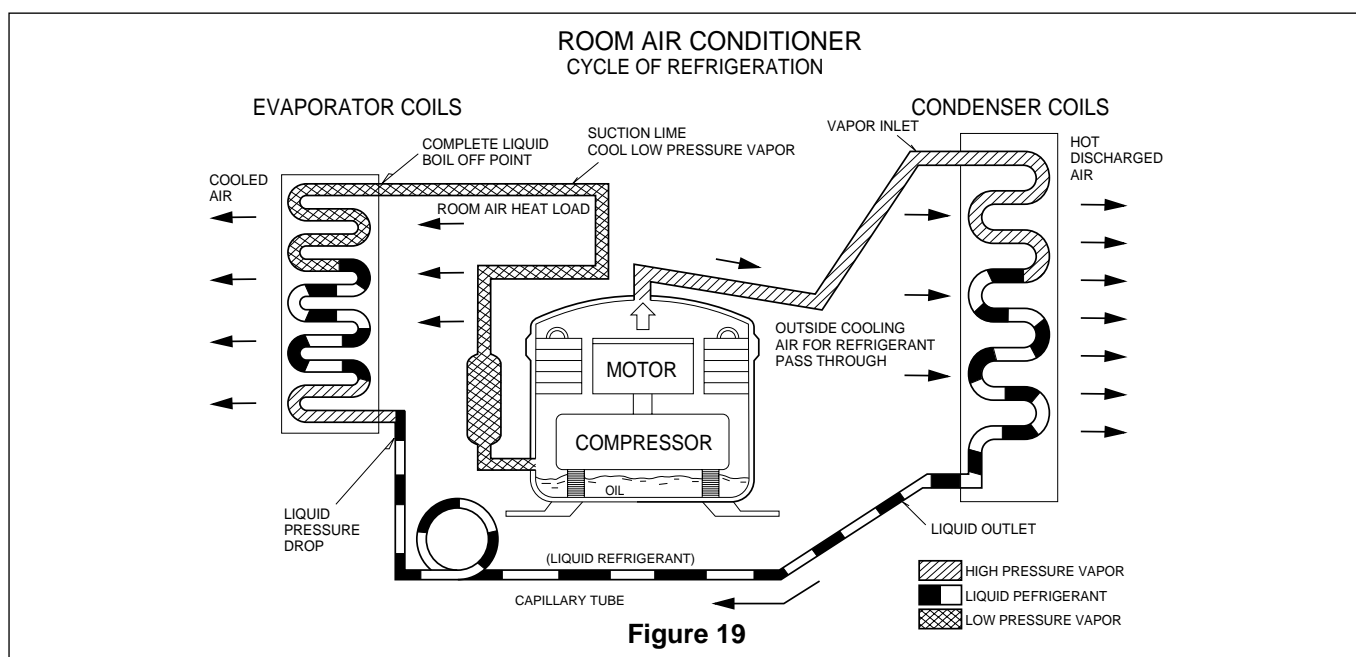

4.3 TROUBLESHOOTING GUIDE

In general, possible trouble is classified in two causes.

The one is called Starting Failure which is caused from an electrical defect, and the other is Ineffective Air Conditioning caused by a defect in the refrigeration circuit and improper application.

Unit is running but cooling is ineffective

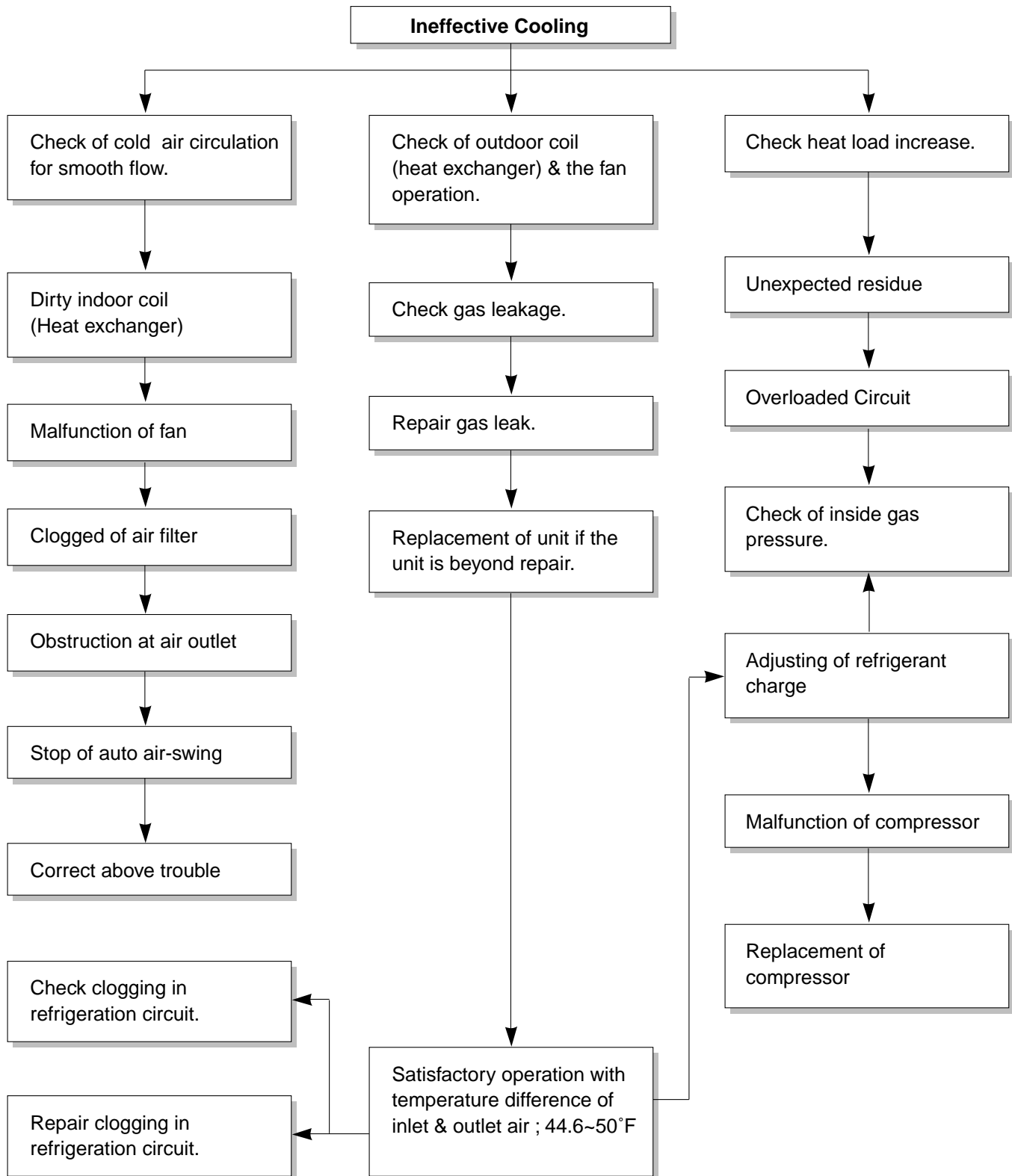

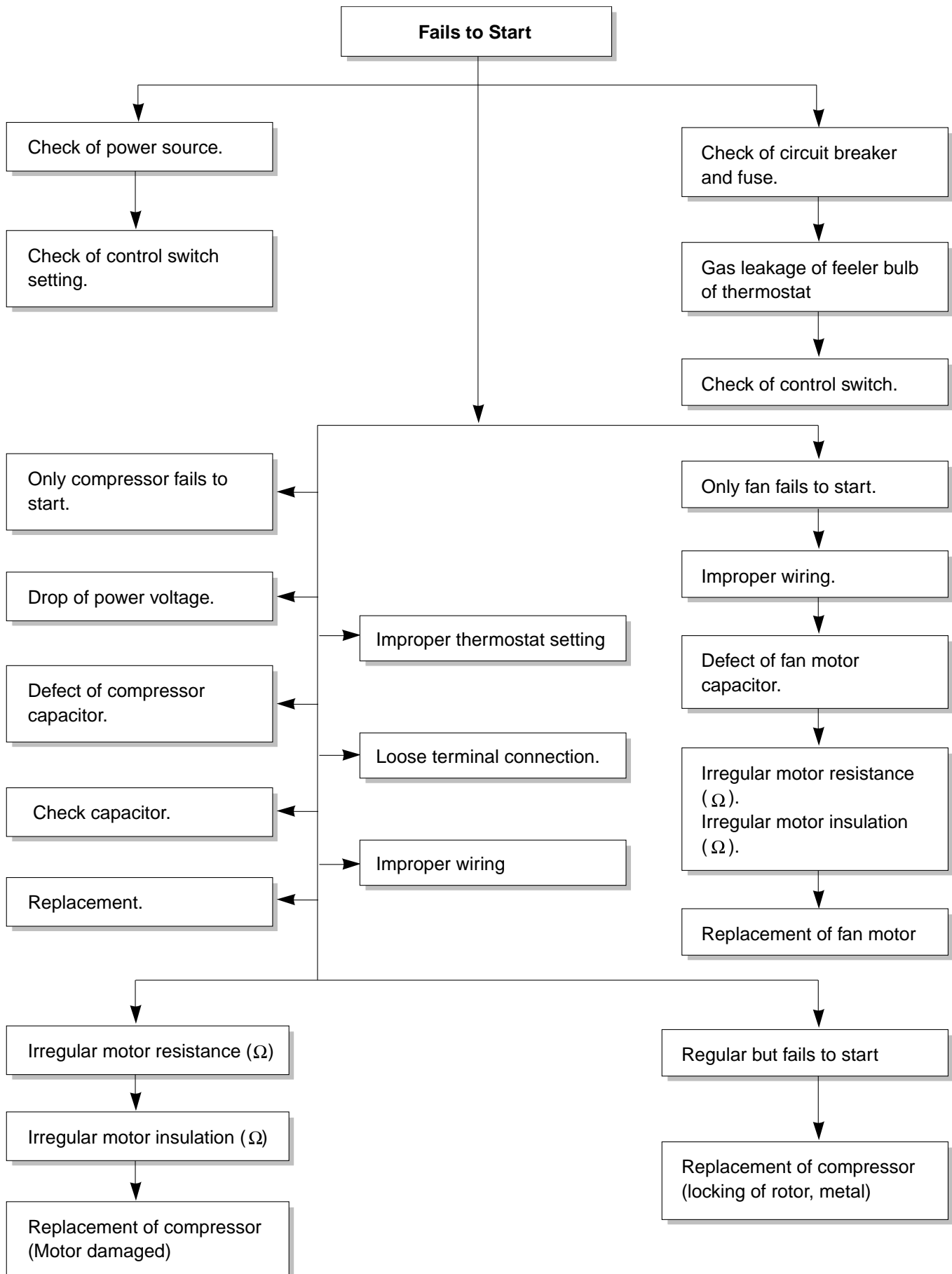

COMPLAINT	CAUSE	REMEDY
Fan motor will not run.	No power	Check voltage at outlet. Correct if none.
	Power supply cord	Check voltage to rotary switch. If none, check power supply cord. Replace cord if circuit is open.
	Rotary switch	Check switch continuity. Refer to wiring diagram for terminal identification. Replace switch if defective.
	Wire disconnected or connection loose	Connect wire. Refer to wiring diagram for terminal identification. Repair or replace loose terminal.
	Capacitor (Discharge capacitor before testing.)	Test capacitor. Replace if not within $\pm 10\%$ of manufacturer's rating. Replace if shorted, open, or damaged.
	Will not rotate	Fan blade hitting shroud or blower wheel hitting scroll. Realign assembly. Units using slinger ring condenser fans must have $\frac{1}{4}$ to $\frac{5}{16}$ inch clearance to the base. If it is hitting the base, shim up the bottom of the fan motor with mounting screw(s). Check fan motor bearings; if motor shaft will not rotate, replace the motor.
Fan motor runs intermittently	Revolves on overload.	Check voltage. See limits on this page. If not within limits, call an electrician. Test capacitor. Check bearings. Does the fan blade rotate freely? If not, replace fan motor. Pay attention to any change from high speed to low speed. If the speed does not change, replace the motor.
Fan motor noise.	Grommets	Check grommets; if worn or missing, replace them.
	Fan	If cracked, out of balance, or partially missing, replace it.
	Turbo fan	If cracked, out of balance, or partially missing, replace it.
	Loose set screw	Tighten it.
	Worn bearings	If knocking sounds continue when running or loose, replace the motor. If the motor hums or noise appears to be internal while running, replace motor.

COMPLAINT	CAUSE	REMEDY
Compressor will not run, but fan motor runs.	Voltage	Check voltage. See the limits on the preceding page. If not within limits, call an electrician.
	Wiring	Check the wire connections, if loose, repair or replace the terminal. If wires are off, refer to wiring diagram for identification, and replace. Check wire locations. If not per wiring diagram, correct.
	Rotary	Check for continuity, refer to the wiring diagram for terminal identification. Replace the switch if circuit is open.
	Thermostat	Check the position of knob. If not at the coldest setting, advance the knob to this setting and restart unit. Check continuity of the thermostat. Replace thermostat if circuit is open.
	Capacitor (Discharge capacitor before servicing.)	Check the capacitor. Replace if not within $\pm 10\%$ of manufacturer's rating. Replace if shorted, open, or damaged.
	Compressor	Check the compressor for open circuit or ground. If open or grounded, replace the compressor.
	Overload	Check the compressor overload, if externally mounted. Replace if open. (If the compressor temperature is high, remove the overload, cool it, and retest.)

ROOM AIR CONDITIONER VOLTAGE LIMITS

NAME PLATE RATING	MINIMUM	MAXIMUM
115V	103.5V	126.5V
208/230V	187V	253V

COMPLAINT	CAUSE	REMEDY
Compressor cycles on overload.	Voltage	Check the voltage. See the limits on the preceding page. If not within limits, call an electrician.
	Overload	Check overload, if externally mounted. Replace if open. (If the compressor temperature is high, remove the overload, cool, and retest.)
	Fan motor	If not running, determine the cause. Replace if required.
	Condenser air flow restriction	Remove the cabinet. inspect the interior surface of the condenser; if restricted, clean carefully with a vacuum cleaner (do not damage fins) or brush. Clean the interior base before reassembling.
	Condenser fins (damaged)	If condenser fins are closed over a large area on the coil surface, head pressures will increase, causing the compressor to cycle. Straighten the fins or replace the coil.
	Capacitor	Test capacitor.
	Wiring	Check the terminals. If loose, repair or replace.
	Refrigerating system	Check the system for a restriction.
Insufficient cooling or heating	Air filter	If restricted, clean or replace.
	Exhaust damper door	Close if open.
	Unit undersized	Determine if the unit is properly sized for the area to be cooled.
Excessive noise.	Blower or fan	Check the set screw or clamp. If loose or missing, correct. If the blower or fan is hitting air guide, rearrange the air handling parts.
	Copper tubing	Remove the cabinet and carefully rearrange tubing not to contact cabinet, compressor, shroud, and barrier.

5. SCHEMATIC DIAGRAM

5.1 CIRCUIT DIAGRAM

• MODEL : BDE-103-A/BDE-123-A

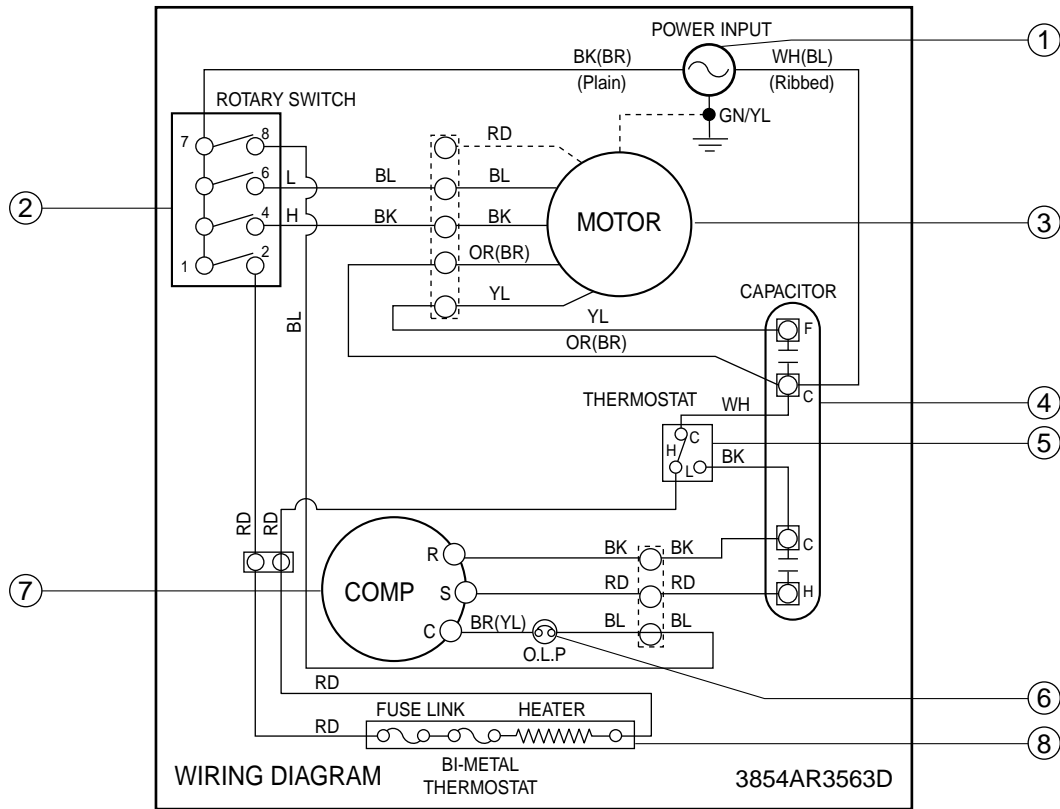

NO.	DESCRIPTION	PART NO.		Q'TY PER SET	RE-MARKS
		BDE-103-A	BDE-123-A		
1	POWER CORD	6411A20048L		1	
2	ROTARY SWITCH	2H00598F		1	
3	FAN MOTOR	4681A20044E	4681A20041M	1	
4	CAPACITOR	6120AR2359E		1	
5	THERMOSTAT	2H01127D		1	
6	OVERLOAD PROTECTOR	6750U-L028A	6750U-L039A	1	
7	COMPRESSOR	2520UKCK2BA	2520UKHK2AA	1	
8	ELECTRIC HEATER	5300A20003A		1	

6. EXPLODED VIEW

• MODEL: BDE-103-A/BDE-123-A

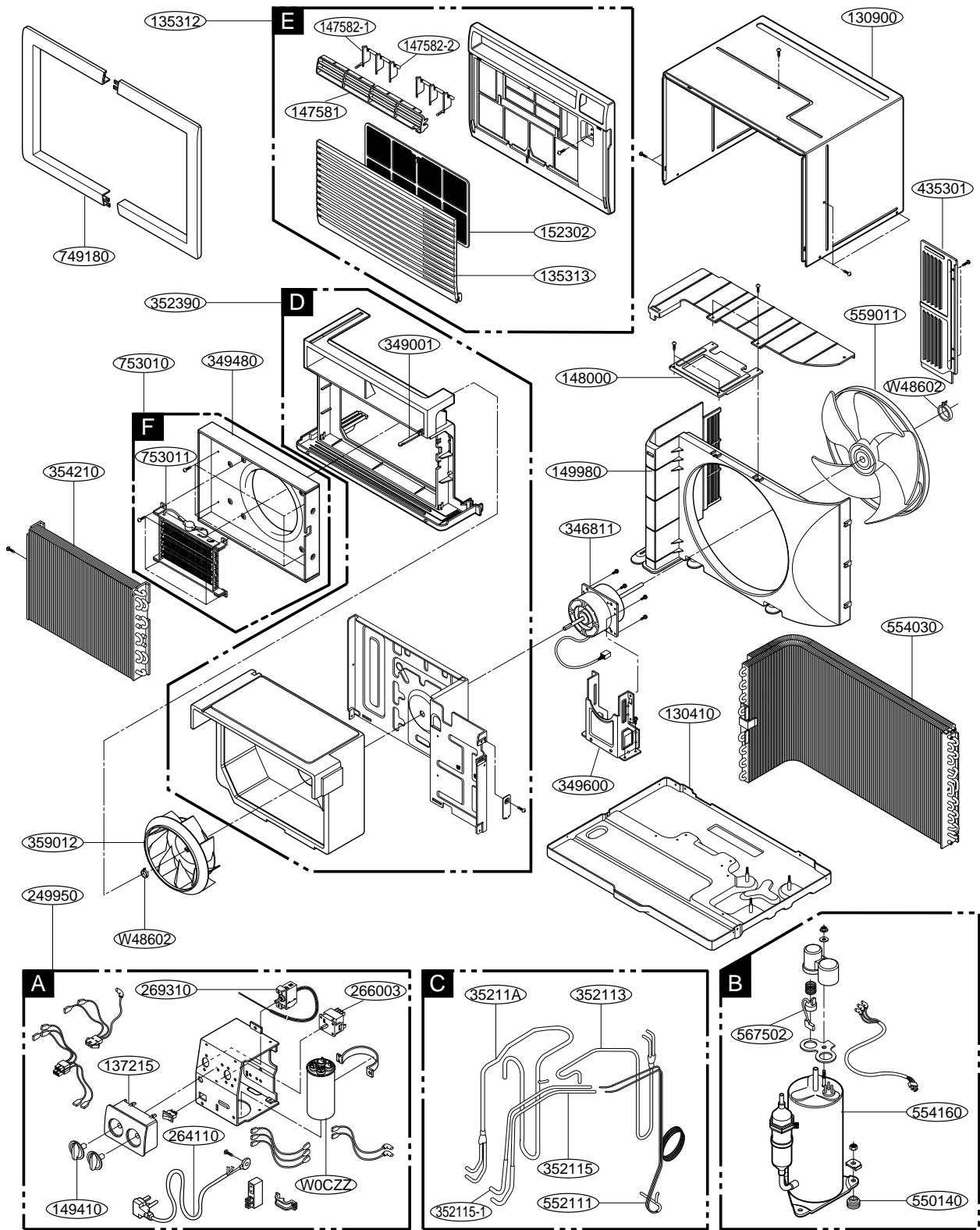

7. REPLACEMENT PARTS LIST

• MODEL: BDE-103-A/BDE-123-A

R: Service Parts
N: Non Service parts

	LOCATION NO.	DESCRIPTION	PART NO.		REMARK
			BDE-103-A	BDE-123-A	
A	249950	CONTROL BOX ASSY, SINGLE	4995A20408E		R
	264110	POWER CORD ASSY	6411A20048L		R
	266003	SWITCH, ROTARY	2H00598F		R
	269310	THERMOSTAT ASSY	2H01127D		R
	W0CZZ	CAPACITOR, DRAWING	6120AR2359E		R
	149410	KNOB ASSY	4941A30005B		R
	137215	PANEL ASSY, CONTROL	3721A20049H		R
B	554160	COMPRESSOR	2520UKCK2BA	2520UKHK2AA	R
	550140	ISOLATOR, COMP	4H00982E		R
	567502	O.L.P	6750U-L028A	6750U-L039A	R
C	352113	TUBE ASSY, DISCHARGE SINGLE	5211A30588B	5211A21421C	R
	352115	TUBE ASSY, EVAPORATOR IN	5211A20289C	5211A29024E	R
	35211A	TUBE ASSY, SUCTION SINGLE	5211A20498B	5211A25028A	R
	552111	TUBE ASSY, CAPILLARY	5211A20214L	5210A22592L/M	R
D	352390	AIR GUIDE ASSY	5239A10002F		R
	349001	DAMPER, VENTILATION	4900A20001A		R
E	135312	GRILLE ASSY, FRONT	3531A20055G		R
	135313	GRILLE, INLET	3530A20020A		R
	147581	LOUVER, HORIZONTAL	4758A20008B		R
	147582-1	LOUVER, VERTICAL	4758A20009A		R
	147582-2	LOUVER, VERTICAL	4758A20009B		R
	152302	FILTER(MESH), A/C	5230A20007A		R
F	753010	HEATER ASSY	5301A20011A		R
	753011	HEATER ASSY, ELECTRIC	5300A20003A		R
	349480	ORIFICE	4948A10006A		R
	149980	SHROUD	4998A10007B		R
	346811	MOTOR ASSY, SINGLE	4681A20044E	4681A20041M	R
	349600	MOUNT, MOTOR	4960A20005A	4960A20008A	R
	148000	BRACE	4800A30002A		R
	435301	GRILLE, REAR	3530A30002A		R
	354210	EVAPORATOR ASSY, FIRST	5421A20071E	5421A20071J	R
	359012	FAN, TURBO	5900A20009B		R
	554030	CONDENSER ASSY, BENT	5403A20040M	5403A20040D	R
	559011	FAN ASSY, AXIAL	5900AR1173A		R
	W48602	CLAMP, SPRING	3H02932B		R
	130410	BASE ASSY, SINGLE	3041A10038D	3041A10038F	R
	130900	CABINET	3090A20003B		R
	749180	TRIM	4918A20001A		R

Specifications and performance data subject to change without notice.

HEAT CONTROLLER, INC.

1900 WELLWORTH AVENUE • JACKSON, MICHIGAN 49203

THE QUALITY LEADER IN CONDITIONING AIR

P/No.: 3828A20040F

Free Manuals Download Website

<http://myh66.com>

<http://usermanuals.us>

<http://www.somanuals.com>

<http://www.4manuals.cc>

<http://www.manual-lib.com>

<http://www.404manual.com>

<http://www.luxmanual.com>

<http://aubethermostatmanual.com>

Golf course search by state

<http://golfingnear.com>

Email search by domain

<http://emailbydomain.com>

Auto manuals search

<http://auto.somanuals.com>

TV manuals search

<http://tv.somanuals.com>