

ISSUED: APR. 29, 1994

REVISED: AUG. 8, 1994

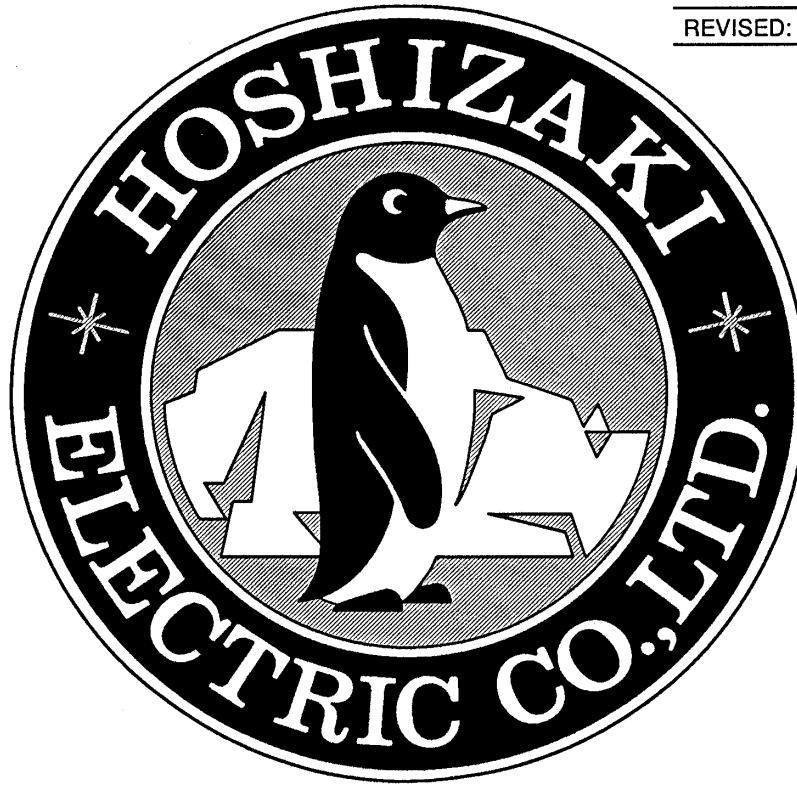

**HOSHIZAKI
CUBELET ICE DISPENSER**

MODEL DCM-240

SERVICE MANUAL

CONTENTS

I. SPECIFICATIONS

1. SPECIFICATIONS

II. GENERAL INFORMATION

1. CONSTRUCTION
2. OPERATION - How it works

III. TECHNICAL INFORMATION

1. WATER CIRCUIT AND REFRIGERANT CIRCUIT
2. WIRING DIAGRAM
3. SEQUENCE OF ELECTRICAL CIRCUIT
4. PERFORMANCE DATA

IV. SERVICE INFORMATION

- ADJUSTMENT OF COMPONENTS
- SERVICE DIAGNOSIS
- REMOVAL AND REPLACEMENT OF COMPONENTS

V. MAINTENANCE AND CLEANING INSTRUCTIONS

1. PREPARING THE ICE DISPENSER FOR LONG STORAGE
2. CLEANING INSTRUCTIONS
3. MAINTENANCE

FOREWORD

This Service Manual contains the specifications and information in regard to transporting, unpacking, installing, operating and servicing the machine. You are encouraged to read it thoroughly in order to obtain maximum performance. You will find details on the construction, installation and maintenance.

If you encounter any problem not covered in this Service Manual, feel free to contact Hoshizaki America, Inc. We will be happy to provide whatever assistance is necessary.

Keep this Service Manual handy, and read it again when questions arise.

HOSHIZAKI AMERICA, INC.

618 HIGHWAY 74 SOUTH, PEACHTREE CITY,
GEORGIA 30269 U.S.A.
PHONE: 404-487-2331

HOSHIZAKI ELECTRIC CO., LTD.

TOYOAKE, AICHI, JAPAN
PHONE: 0562-97-2111
TELEX-NO: 04486-514 HOSHI J

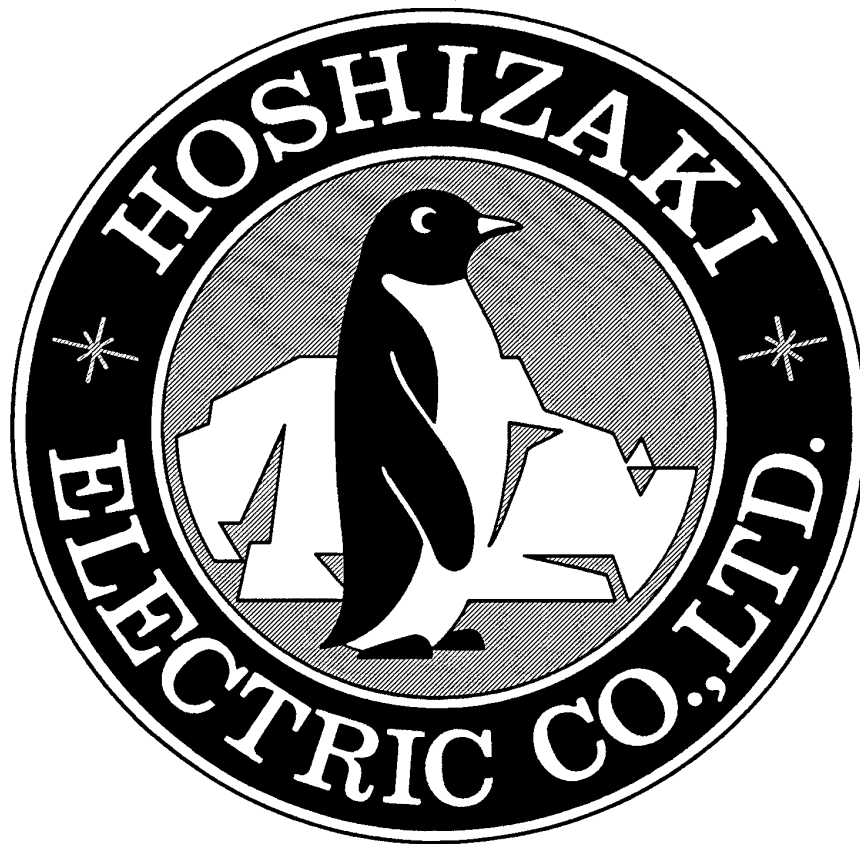

**HOSHIZAKI
CUBELET ICE DISPENSER**

**I.
SPECIFICATIONS**

CONTENTS

PAGE

1. SPECIFICATIONS	I-1
DCM-240BAA	I-1
DCM-240BAB	I-2
DCM-240BAE	I-3

ICM9404

1. SPECIFICATIONS

DCM-240BAA

AC SUPPLY VOLTAGE	115/60/1																							
AMPERAGE	5.8 A (AT 104° F/ WT 80° F)																							
MINIMUM CIRCUIT AMPACITY	N/A																							
MAXIMUM FUSE SIZE	N/A																							
APPROXIMATE ICE PRODUCTION PER 24 HR.	<table border="1"> <thead> <tr> <th rowspan="2">Ambient Temp. (° F)</th> <th colspan="3">Water Temp. (° F)</th> </tr> <tr> <th>50</th> <th>70</th> <th>90</th> </tr> </thead> <tbody> <tr> <td>70</td> <td>* 225 (102)</td> <td>214 (97)</td> <td>209 (95)</td> </tr> <tr> <td>80</td> <td>209 (95)</td> <td>205 (93)</td> <td>203 (92)</td> </tr> <tr> <td>90</td> <td>196 (89)</td> <td>* 192 (87)</td> <td>187 (87)</td> </tr> <tr> <td>100</td> <td>170 (77)</td> <td>168 (76)</td> <td>165 (75)</td> </tr> </tbody> </table>	Ambient Temp. (° F)	Water Temp. (° F)			50	70	90	70	* 225 (102)	214 (97)	209 (95)	80	209 (95)	205 (93)	203 (92)	90	196 (89)	* 192 (87)	187 (87)	100	170 (77)	168 (76)	165 (75)
Ambient Temp. (° F)			Water Temp. (° F)																					
		50	70	90																				
70		* 225 (102)	214 (97)	209 (95)																				
80		209 (95)	205 (93)	203 (92)																				
90	196 (89)	* 192 (87)	187 (87)																					
100	170 (77)	168 (76)	165 (75)																					
lbs./day (kg/day)																								
Reference without *marks																								
SHAPE OF ICE	Cubelet (Compressed Flake ice)																							
ICE QUALITY	Approx. 90 % Ice (90/ 70° F, Conductivity 200 μ s/cm)																							
APPROXIMATE STORAGE CAPACITY	8.8 lbs.																							
ELECTRIC & WATER CONSUMPTION	90° F/ 70° F, 70° F/ 50° F,																							
ELECTRIC W (KWH/100 lbs.)	640 (8.0) 625 (6.7)																							
POTABLE WATER	23 (12.0) 27 (12.0)																							
gal./24HR (gal./100 lbs.)																								
EXTERIOR DIMENSIONS (WxDxH)	16-9/16" x 23-1/16" x 31-1/2" (420 x 586 x 800 mm)																							
EXTERIOR FINISH	Stainless Steel, Painted Steel (Top)																							
WEIGHT	Net 141 lbs. (64 kg), Shipping 170 lbs. (77 kg)																							
CONNECTIONS - ELECTRIC	Cord Connection																							
- WATER SUPPLY	Inlet 1/2" FPT																							
- DRAIN	Outlet 3/4" MPT																							
ICE MAKING SYSTEM	Auger type																							
HARVESTING SYSTEM	Direct driven Auger (80 W Gear Motor)																							
ICE MAKING WATER CONTROL	Float Switch																							
COOLING WATER CONTROL	N/A																							
BIN CONTROL SYSTEM	Mechanical Bin Control (Microswitch)																							
COMPRESSOR	Hermetic 400 W, Model CL50J-1U																							
CONDENSER	Air-cooled, Fin and tube type																							
EVAPORATOR	Copper Tube on Cylinder																							
REFRIGERANT CONTROL	Constant Pressure Expansion Valve																							
REFRIGERANT CHARGE	R12, 8.8 oz. (250 g)																							
DESIGN PRESSURE	High 235 PSIG, Low 140 PSIG																							
COMPRESSOR PROTECTION	Auto-reset Overload Protector																							
GEAR MOTOR PROTECTION	Manual reset Circuit Breaker																							
REFRIGERANT CIRCUIT PROTECTION	N/A																							
LOW WATER PROTECTION	Float Switch and Timer																							
ACCESSORIES - SUPPLIED	Spare Fuse																							
- REQUIRED	N/A																							
OPERATING CONDITIONS	VOLTAGE RANGE 104 - 127 V																							
	AMBIENT TEMP. 45 - 100° F																							
	WATER SUPPLY TEMP. 45 - 90° F																							
	WATER SUPPLY PRESS. 10 - 113 PSIG																							

* We reserve the right to make changes in specifications and design without prior notice.

DCM-240BAB

AC SUPPLY VOLTAGE	115/60/1																							
AMPERAGE	5.8 A (AT 104° F/WT 80 ° F)																							
MINIMUM CIRCUIT AMPACITY	N/A																							
MAXIMUM FUSE SIZE	N/A																							
APPROXIMATE ICE PRODUCTION PER 24 HR.	<table border="1"> <thead> <tr> <th rowspan="2">Ambient Temp. (° F)</th> <th colspan="3">Water Temp. (° F)</th> </tr> <tr> <th>50</th> <th>70</th> <th>90</th> </tr> </thead> <tbody> <tr> <td>70</td> <td>* 225(102)</td> <td>214(97)</td> <td>209(95)</td> </tr> <tr> <td>80</td> <td>209 (95)</td> <td>205(93)</td> <td>203(92)</td> </tr> <tr> <td>90</td> <td>196 (89)</td> <td>* 192(87)</td> <td>187(87)</td> </tr> <tr> <td>100</td> <td>170 (77)</td> <td>168(76)</td> <td>165(75)</td> </tr> </tbody> </table>	Ambient Temp. (° F)	Water Temp. (° F)			50	70	90	70	* 225(102)	214(97)	209(95)	80	209 (95)	205(93)	203(92)	90	196 (89)	* 192(87)	187(87)	100	170 (77)	168(76)	165(75)
Ambient Temp. (° F)			Water Temp. (° F)																					
		50	70	90																				
70		* 225(102)	214(97)	209(95)																				
80		209 (95)	205(93)	203(92)																				
90	196 (89)	* 192(87)	187(87)																					
100	170 (77)	168(76)	165(75)																					
lbs./day (kg/day)																								
Reference without *marks																								
SHAPE OF ICE	Cubelet (Compressed Flake Ice)																							
ICE QUALITY	Approx. 90 % Ice (90/ 70° F, Conductivity 200 μs/cm)																							
APPROXIMATE STORAGE CAPACITY	8.8 lbs.																							
ELECTRIC & WATER CONSUMPTION	90 ° F/ 70° F, 70° F/ 50° F.																							
ELECTRIC W (kWH/100 lbs.)	640 (8.0) 625 (6.7)																							
POTABLE WATER	23 (12.0) 27 (12.0)																							
gal./24HR (gal./100 lbs.)																								
EXTERIOR DIMENSIONS (WxDxH)	16-9/16" x 23-1/16 " x 31-1/2" (420 x 586 x 800 mm)																							
EXTERIOR FINISH	Stainless Steel, Painted Steel(Top)																							
WEIGHT	Net 141 lbs. (64 kg), Shipping 170 lbs. (77 kg)																							
CONNECTIONS - ELECTRIC	Cord Connection																							
- WATER SUPPLY	Inlet 1/2" FPT																							
- DRAIN	Outlet 3/4" MPT																							
ICE MAKING SYSTEM	Auger type																							
HARVESTING SYSTEM	Direct driven Auger (80 W Gear Motor)																							
ICE MAKING WATER CONTROL	Float Switch																							
COOLING WATER CONTROL	N/A																							
BIN CONTROL SYSTEM	Mechanical Bin Control (Microswitch)																							
COMPRESSOR	Hermetic 400 W, Model CL50J-1U																							
CONDENSER	Air-cooled, Fin and tube type																							
EVAPORATOR	Copper Tube on Cylinder																							
REFRIGERANT CONTROL	Constant Pressure Expansion Valve																							
REFRIGERANT CHARGE	R12, 8.8 oz. (250 g)																							
DESIGN PRESSURE	High 235 PSIG, Low 140 PSIG																							
COMPRESSOR PROTECTION	Auto-reset Overload Protector																							
GEAR MOTOR PROTECTION	Manual reset Circuit Breaker																							
REFRIGERANT CIRCUIT PROTECTION	N/A																							
LOW WATER PROTECTION	Float Switch and Timer																							
ACCESSORIES - SUPPLIED	Spare Fuse																							
- REQUIRED	N/A																							
OPERATING CONDITIONS	<table> <tr> <td>VOLTAGE RANGE</td> <td>104 - 127 V</td> </tr> <tr> <td>AMBIENT TEMP.</td> <td>45 - 100° F</td> </tr> <tr> <td>WATER SUPPLY TEMP.</td> <td>45 - 90° F</td> </tr> <tr> <td>WATER SUPPLY PRESS.</td> <td>10 - 113 PSIG</td> </tr> </table>	VOLTAGE RANGE	104 - 127 V	AMBIENT TEMP.	45 - 100° F	WATER SUPPLY TEMP.	45 - 90° F	WATER SUPPLY PRESS.	10 - 113 PSIG															
VOLTAGE RANGE	104 - 127 V																							
AMBIENT TEMP.	45 - 100° F																							
WATER SUPPLY TEMP.	45 - 90° F																							
WATER SUPPLY PRESS.	10 - 113 PSIG																							

* We reserve the right to make changes in specifications and design without prior notice.

DCM-240BAE

AC SUPPLY VOLTAGE	115/60/1																							
AMPERAGE	7.4 A (AT 104° F/WT 80 ° F)																							
MINIMUM CIRCUIT AMPACITY	N/A																							
MAXIMUM FUSE SIZE	N/A																							
APPROXIMATE ICE PRODUCTION PER 24 HR.	<table border="1"> <thead> <tr> <th rowspan="2">Ambient Temp. (° F)</th> <th colspan="3">Water Temp. (° F)</th> </tr> <tr> <th>50</th> <th>70</th> <th>90</th> </tr> </thead> <tbody> <tr> <td>70</td> <td>* 290(131)</td> <td>280(127)</td> <td>270(122)</td> </tr> <tr> <td>80</td> <td>270(122)</td> <td>250(113)</td> <td>230(104)</td> </tr> <tr> <td>90</td> <td>240(108)</td> <td>* 230(104)</td> <td>200 (90)</td> </tr> <tr> <td>100</td> <td>200 (90)</td> <td>180 (82)</td> <td>165 (75)</td> </tr> </tbody> </table>	Ambient Temp. (° F)	Water Temp. (° F)			50	70	90	70	* 290(131)	280(127)	270(122)	80	270(122)	250(113)	230(104)	90	240(108)	* 230(104)	200 (90)	100	200 (90)	180 (82)	165 (75)
Ambient Temp. (° F)			Water Temp. (° F)																					
		50	70	90																				
70		* 290(131)	280(127)	270(122)																				
80		270(122)	250(113)	230(104)																				
90	240(108)	* 230(104)	200 (90)																					
100	200 (90)	180 (82)	165 (75)																					
lbs./day (kg/day)																								
Reference without *marks																								
SHAPE OF ICE	Cubelet (Compressed Flake Ice)																							
ICE QUALITY	Approx. 90 % Ice (90/ 70° F, Conductivity 200 μ s/cm)																							
APPROXIMATE STORAGE CAPACITY	8.8 lbs.																							
ELECTRIC & WATER CONSUMPTION	90 ° F/ 70° F, 70° F/ 50° F,																							
ELECTRIC W (kWH/100 lbs.)	770 (8.0) 740 (6.1)																							
POTABLE WATER	34 (12.0) 27 (12.0)																							
gal./24HR (gal./100 lbs.)																								
EXTERIOR DIMENSIONS (WxDxH)	16-9/16" x 23-1/16 " x 31-1/2" (420 x 586 x 800 mm)																							
EXTERIOR FINISH	Stainless Steel, Painted Steel(Top)																							
WEIGHT	Net 143 lbs. (65 kg), Shipping 161 lbs. (73 kg)																							
CONNECTIONS - ELECTRIC	Cord Connection																							
- WATER SUPPLY	Inlet 1/2" FPT																							
- DRAIN	Outlet 3/4" MPT																							
ICE MAKING SYSTEM	Auger type																							
HARVESTING SYSTEM	Direct driven Auger (80 W Gear Motor)																							
ICE MAKING WATER CONTROL	Float Switch																							
COOLING WATER CONTROL	N/A																							
BIN CONTROL SYSTEM	Mechanical Bin Control (Microswitch)																							
COMPRESSOR	Hermetic 400 W, Model CF180J1N-1U																							
CONDENSER	Air-cooled, Fin and tube type																							
EVAPORATOR	Copper Tube on Cylinder																							
REFRIGERANT CONTROL	Constant Pressure Expansion Valve																							
REFRIGERANT CHARGE	R22, 11.6 oz. (330 g)																							
DESIGN PRESSURE	High 420 PSIG, Low 230 PSIG																							
COMPRESSOR PROTECTION	Auto-reset Overload Protector																							
GEAR MOTOR PROTECTION	Manual reset Circuit Breaker																							
REFRIGERANT CIRCUIT PROTECTION	N/A																							
LOW WATER PROTECTION	Float Switch and Timer																							
ACCESSORIES - REQUIRED	N/A																							
OPERATING CONDITIONS	<table border="0"> <tr> <td>VOLTAGE RANGE</td> <td>104 - 127 V</td> </tr> <tr> <td>AMBIENT TEMP.</td> <td>45 - 100° F</td> </tr> <tr> <td>WATER SUPPLY TEMP.</td> <td>45 - 90° F</td> </tr> <tr> <td>WATER SUPPLY PRESS.</td> <td>10 - 113 PSIG</td> </tr> </table>	VOLTAGE RANGE	104 - 127 V	AMBIENT TEMP.	45 - 100° F	WATER SUPPLY TEMP.	45 - 90° F	WATER SUPPLY PRESS.	10 - 113 PSIG															
VOLTAGE RANGE	104 - 127 V																							
AMBIENT TEMP.	45 - 100° F																							
WATER SUPPLY TEMP.	45 - 90° F																							
WATER SUPPLY PRESS.	10 - 113 PSIG																							

* We reserve the right to make changes in specifications and design without prior notice.

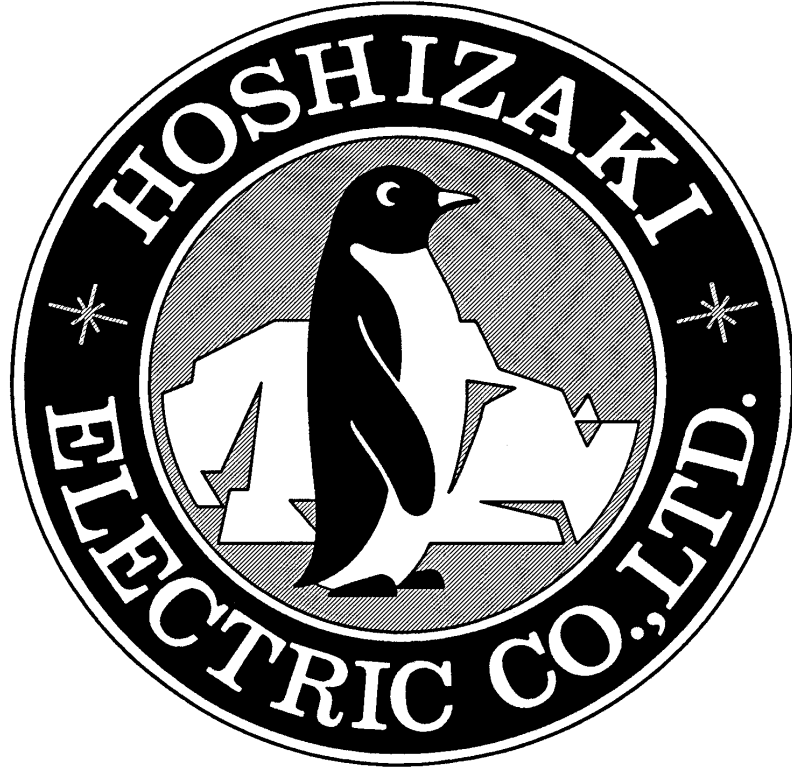

**HOSHIZAKI
CUBELET ICE DISPENSER**

**II.
GENERAL INFORMATION**

CONTENTS

	PAGE
1. CONSTRUCTION	II-1
2. OPERATION - How it works	II-3

1. CONSTRUCTION

Hoshizaki Cubelet Ice Dispenser, models DCM-240BAA, DCM-240BAB and DCM-240BAE include Water Supply, Freezer, Condensing, Storage, Dispensing and Control Assemblies.

DCM-240BAA

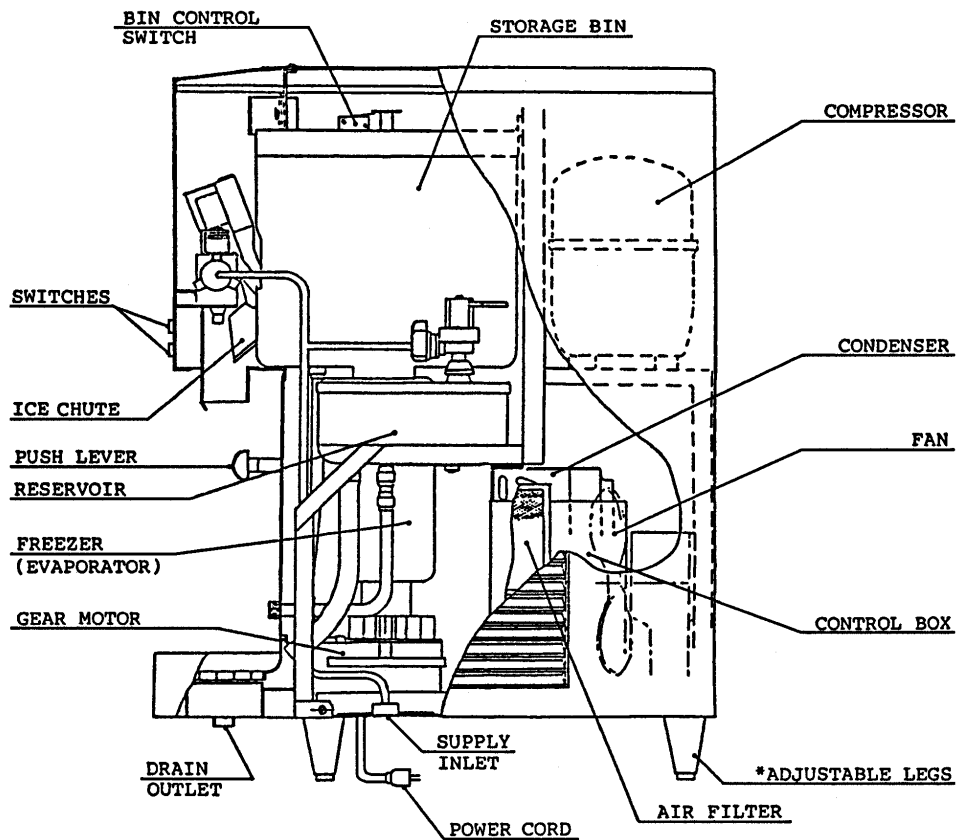

Note: * Adjustable Legs
Minimum height - 4"
Maximum height - 5.3"
Do not adjust exceeding the above recommendation.

**DCM-240BAB
DCM-240BAE**

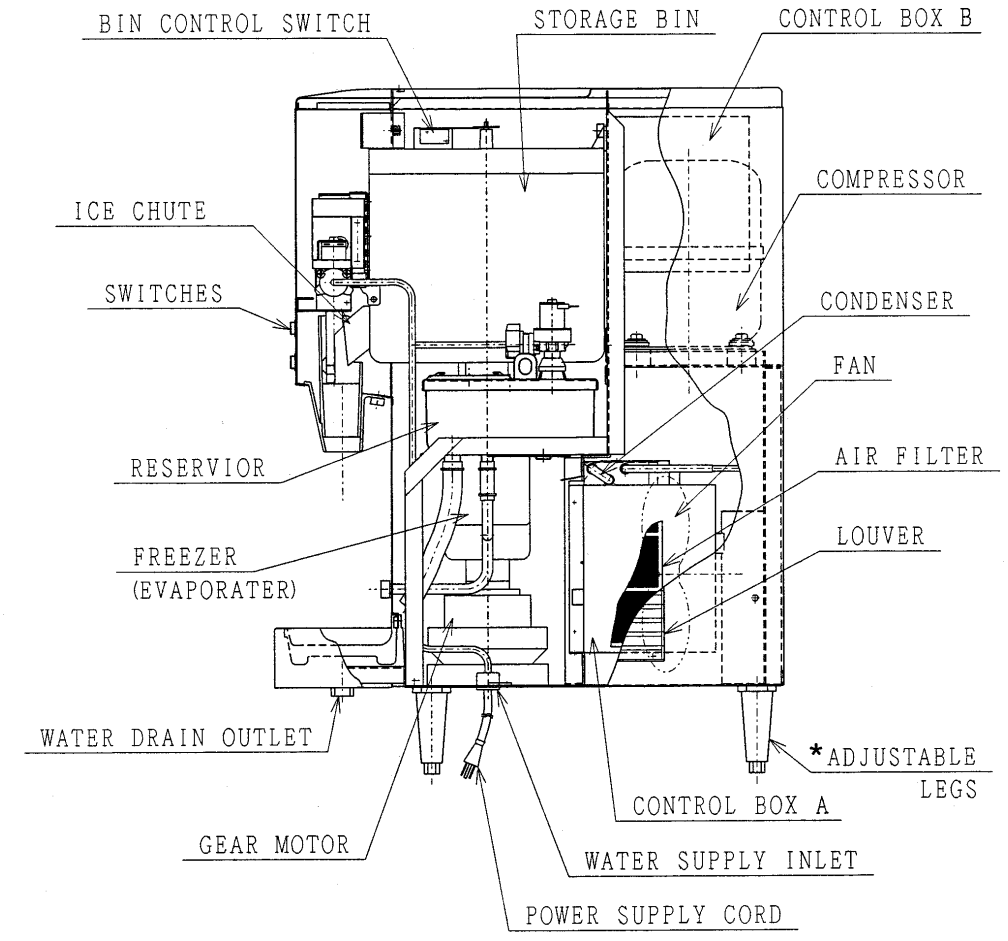

Note: * Adjustable Legs
 Minimum height - 4"
 Maximum height - 5.3"
 Do not adjust exceeding the above recommendation.

2. OPERATION - How it works

Water flows from the potable water source through the Water Supply Line Shut-off Valve, enters at the Water Inlet fitting and into the Water Reservoir. The Water Reservoir functions to maintain a constant water level inside the Freezer Assembly. Water from the Water Reservoir enters at the bottom of the Freezer. Heat is removed by the refrigeration process and ice forms inside the Freezer.

A stainless steel Auger, located inside the Freezer, is direct-driven by the Gear Motor, and the rotating Auger carries the ice upward to the end of the Auger, where excess water is pressed out of the ice, as the ice is extruded and broken into cubelet ice (compressed ice) and then pushed out into the Storage Bin.

Moving the Power Switch and the Ice Making Switch, on the left of the Middle Front Panel, to the "ON" position starts the automatic and continuous icemaking process. When the Ice Storage Bin is filled with ice, the Bin Control Switch will shut off the icemaking process. As the ice is removed from the Storage Bin, the Bin Control Switch resets automatically and restarts the icemaking process.

Moving the Ice Switch and the Water Switch, located on the right of the Middle Front Panel, to the "ON" and/or "OFF" positions gives the user a convenient 3-way dispensing.

Switch Choice	Ice Switch	Water Switch
Ice Only	ON	OFF
Water Only	OFF	ON
Ice and Water	ON	ON

The Agitator in the Storage Bin keeps the ice from clustering so that the ice can move easily through the Spout.

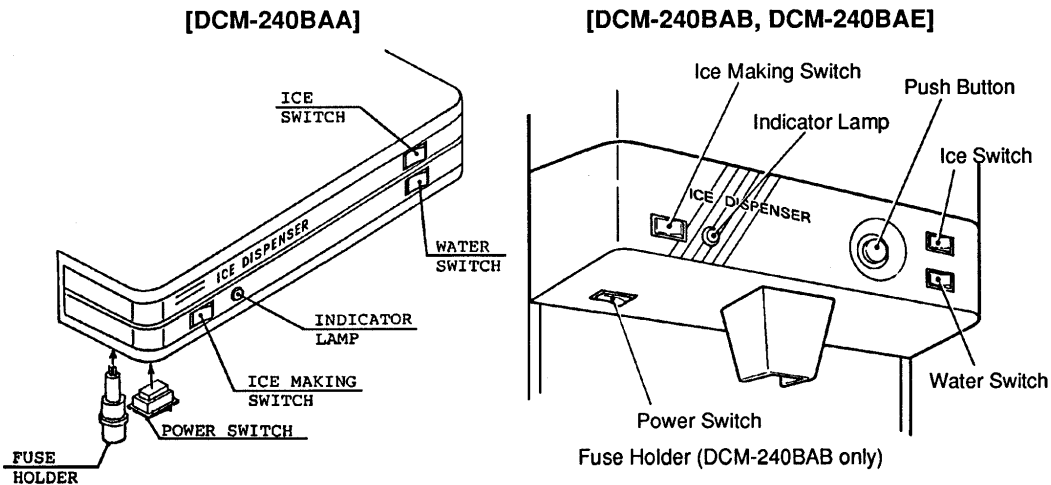

DCM9404

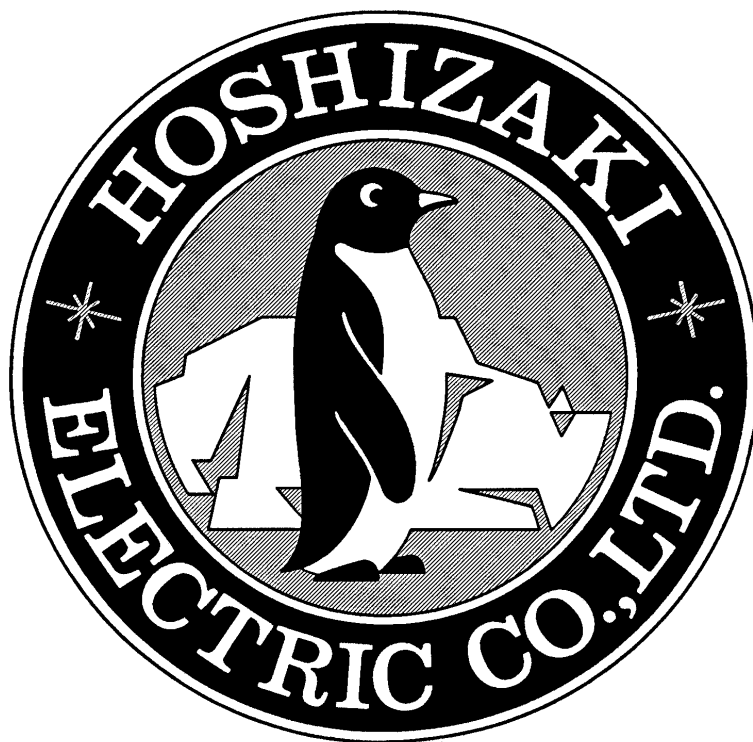

**HOSHIZAKI
CUBELET ICE DISPENSER**

**III.
TECHNICAL INFORMATION**

CONTENTS

	PAGE
1. WATER CIRCUIT AND REFRIGERANT CIRCUIT	III-1
DCM-240BAA, DCM-240BAB	III-1
DCM-240BAE	III-2
2. WIRING DIAGRAM	III-3
DCM-240BAA	III-3
DCM-240BAB	III-4
DCM-240BAE	III-5
3. SEQUENCE OF ELECTRICAL CIRCUIT	III-6
4. PERFORMANCE DATA	III-34
DCM-240BAA	III-34
DCM-240BAB	III-35
DCM-240BAE	III-36

1. WATER CIRCUIT AND REFRIGERANT CIRCUIT

DCM-240BAA, DCM-240BAB

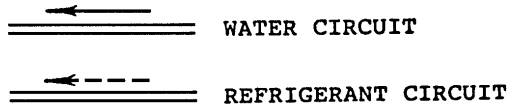
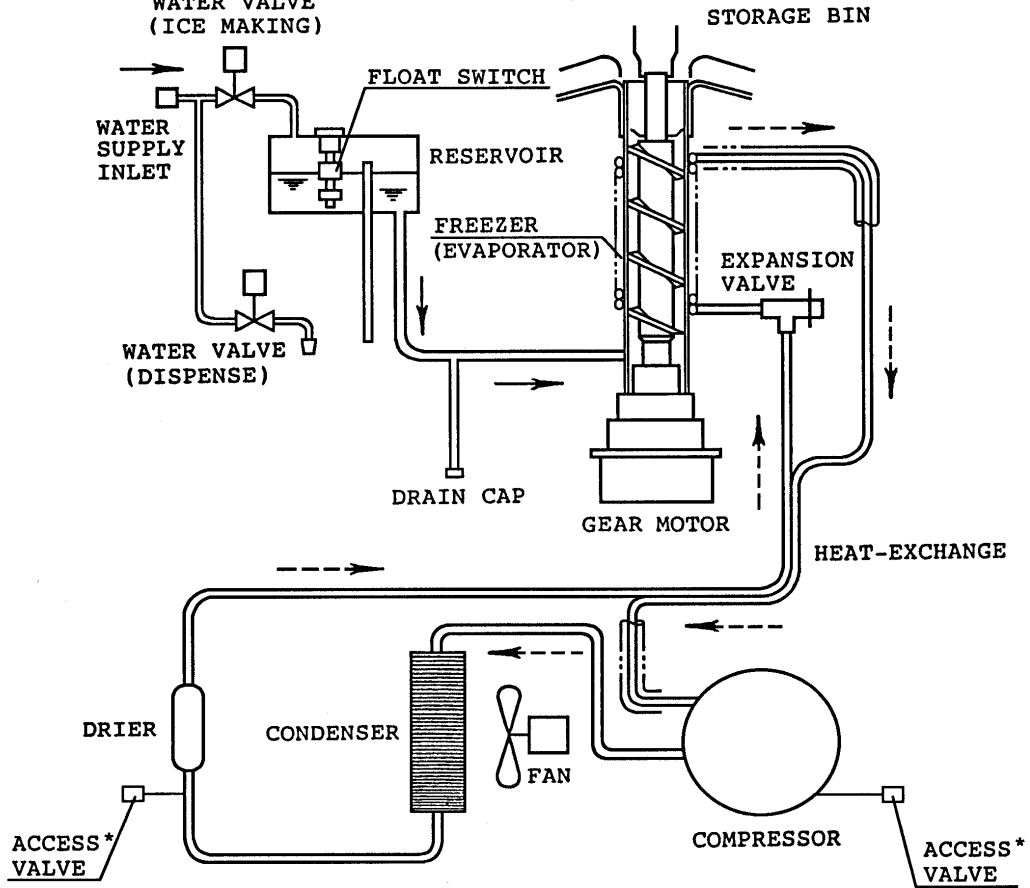

Note: The Access Valves have been installed in the model DCM-240BAB from the Auxiliary Code B-3.

DCM-240BAE

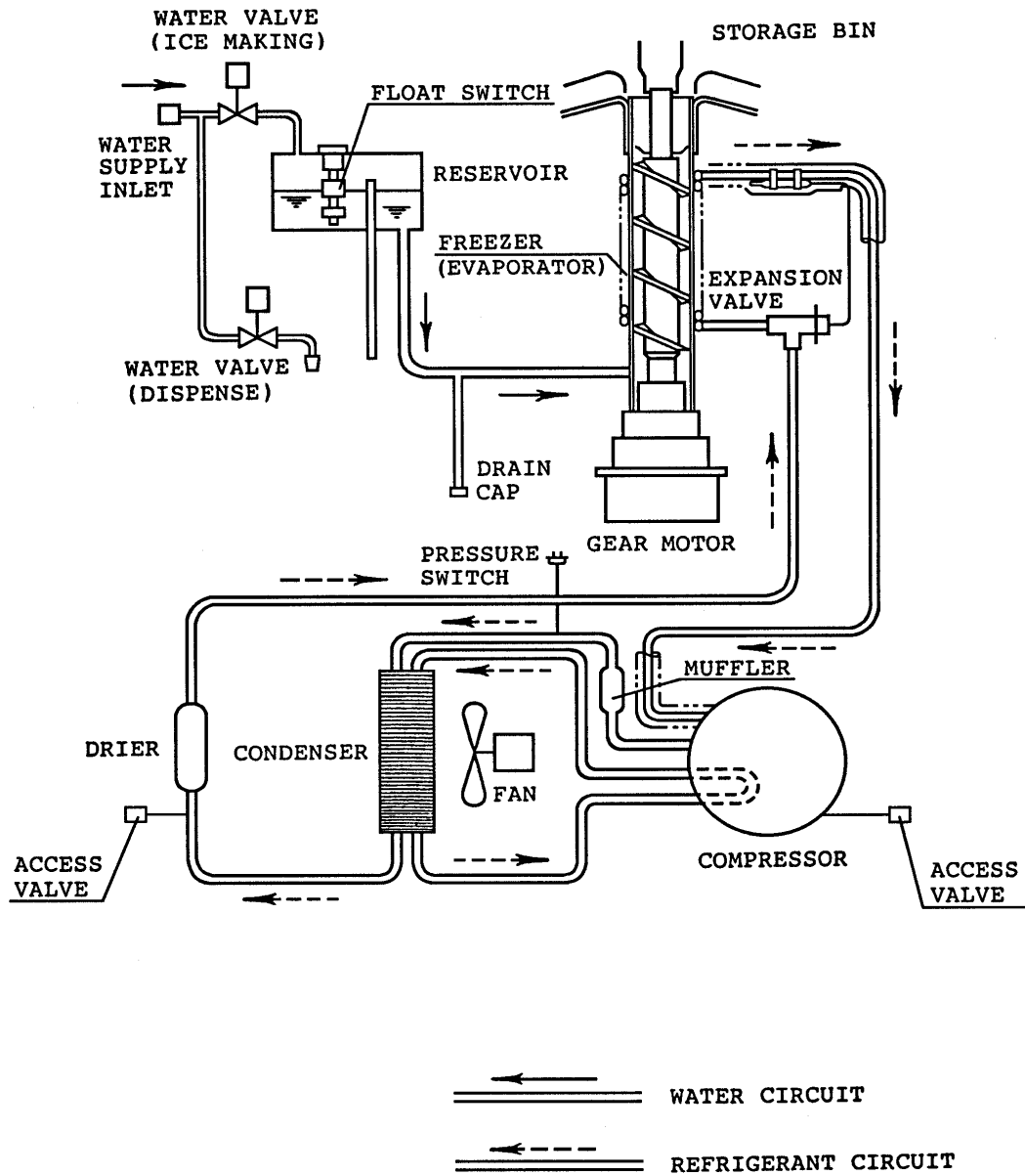

2. WIRING DIAGRAM

DCM-240BAA

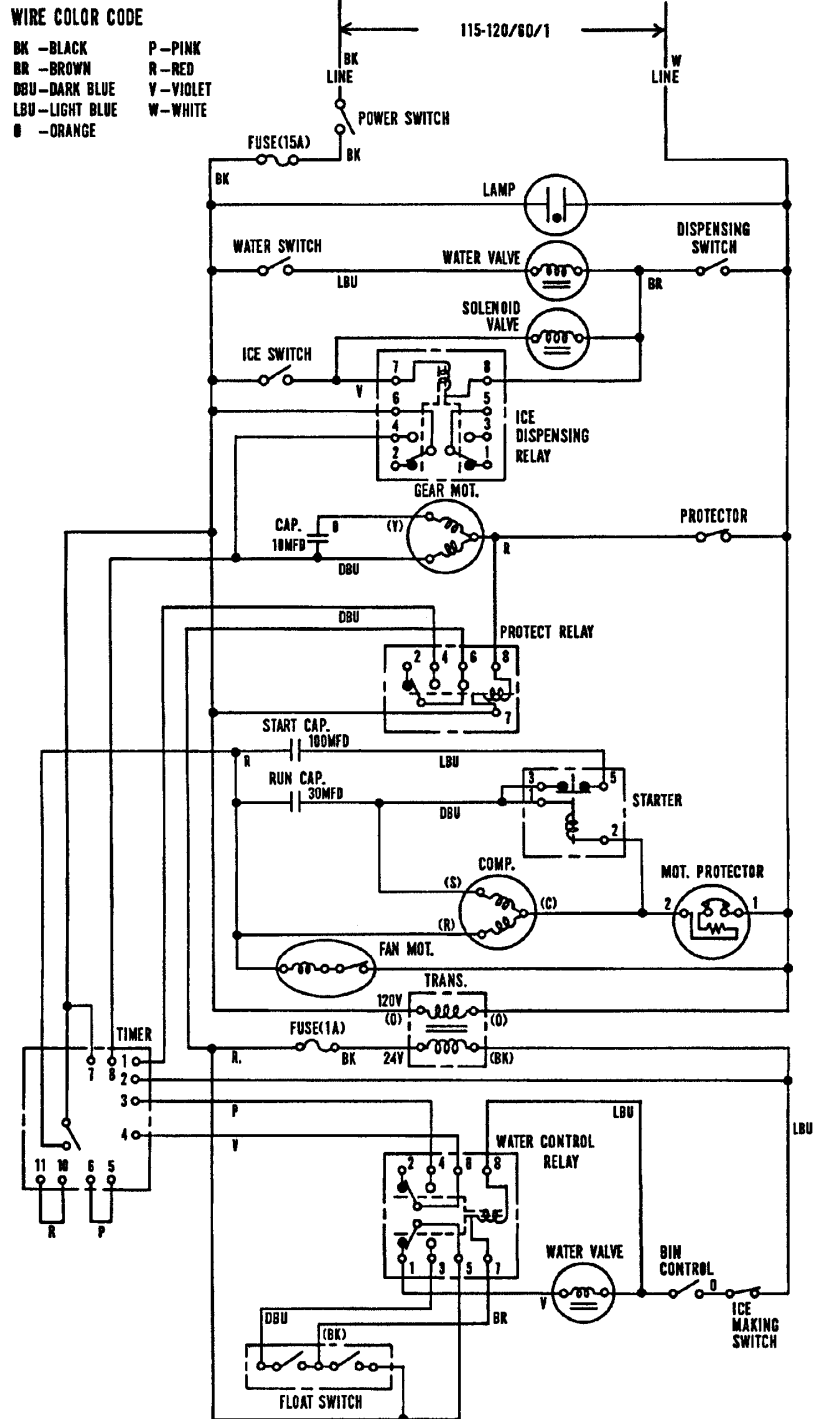

DCM-240BAB

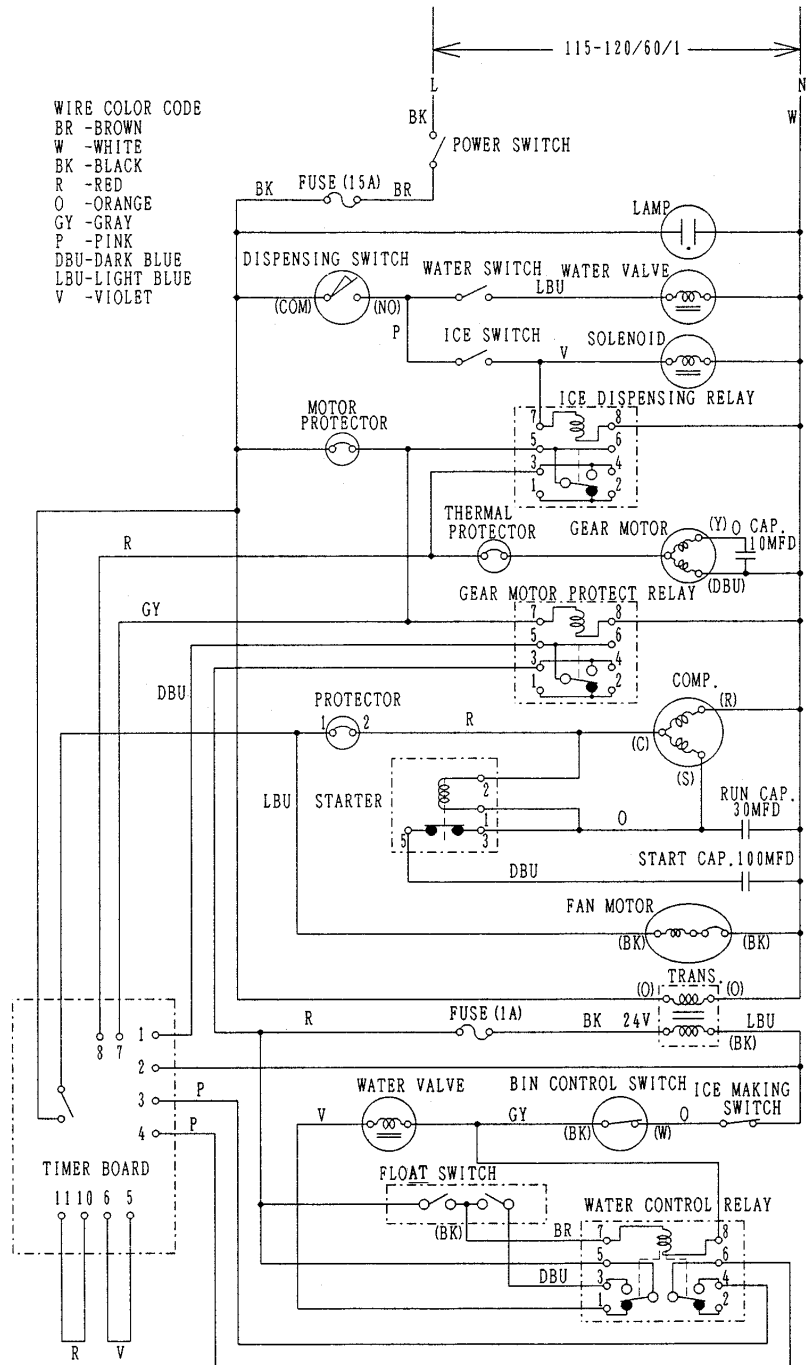

DCM-240BAE

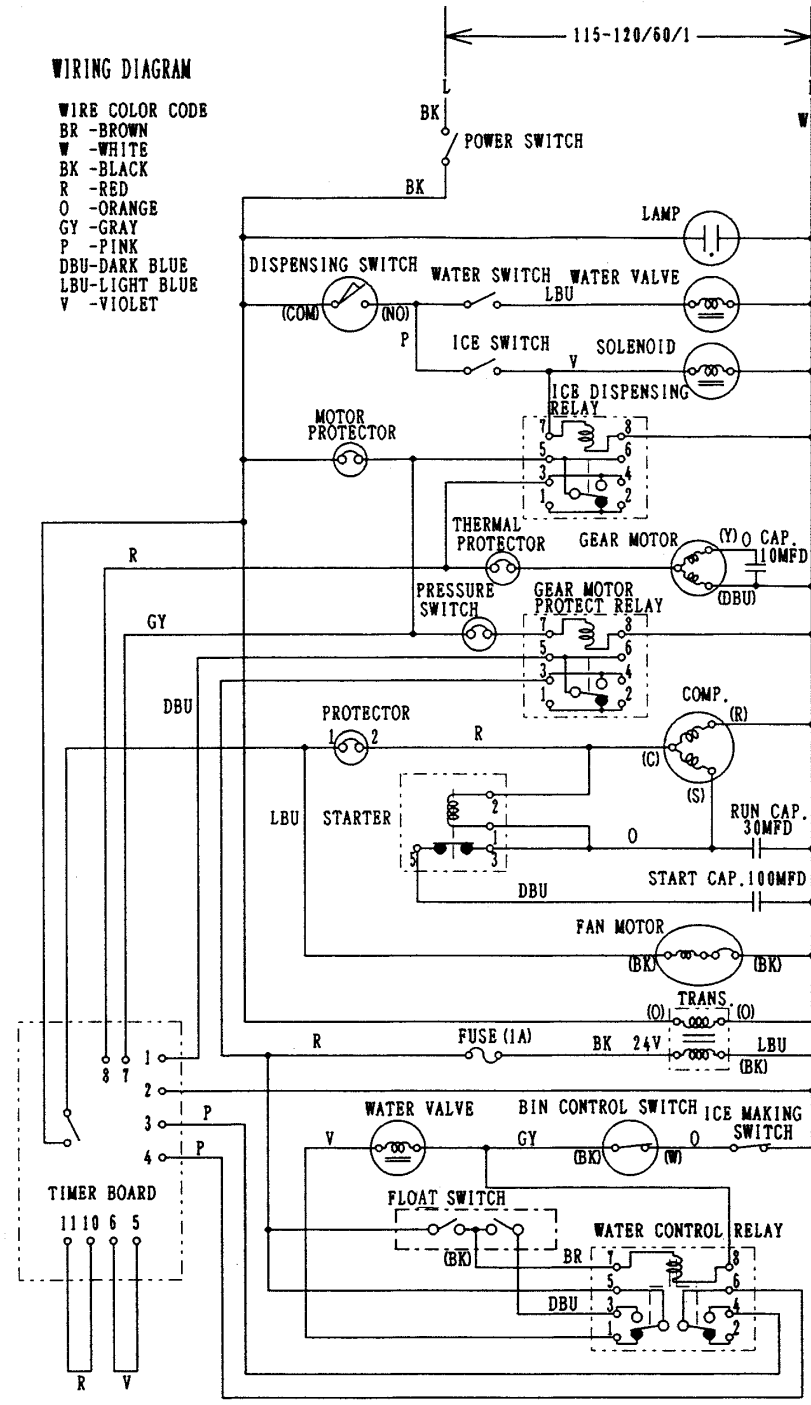

3. SEQUENCE OF ELECTRICAL CIRCUIT

[a] When Power Switch and Ice Making Switch are moved to "ON" position, water starts to be supplied to Reservoir.

WIRE COLOR CODE

BK - BLACK	P - PINK
BR - BROWN	R - RED
DBU - DARK BLUE	V - VIOLET
LBU - LIGHT BLUE	W - WHITE
Ø - ORANGE	

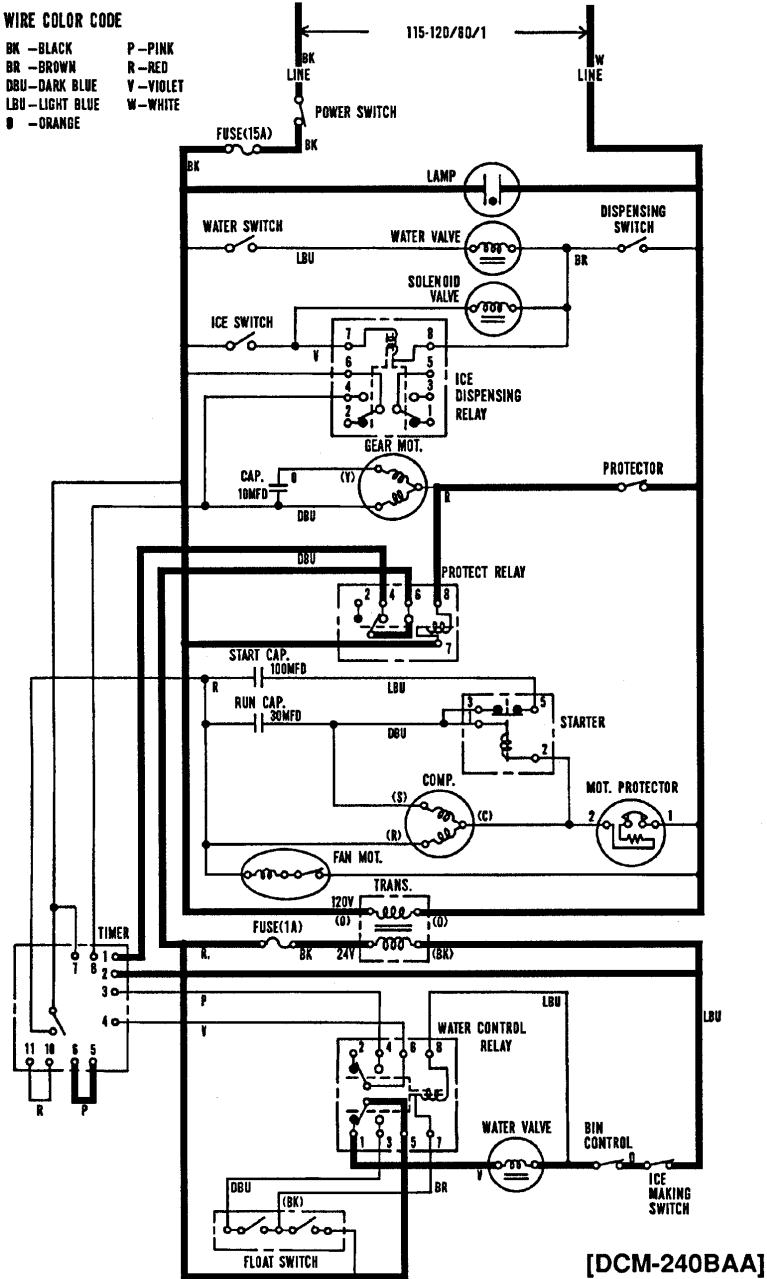

DCM9404

WIRE COLOR CODE
 BR - BROWN
 W - WHITE
 BK - BLACK
 R - RED
 O - ORANGE
 GY - GRAY
 P - PINK
 DBU - DARK BLUE
 LBU - LIGHT BLUE
 V - VIOLET

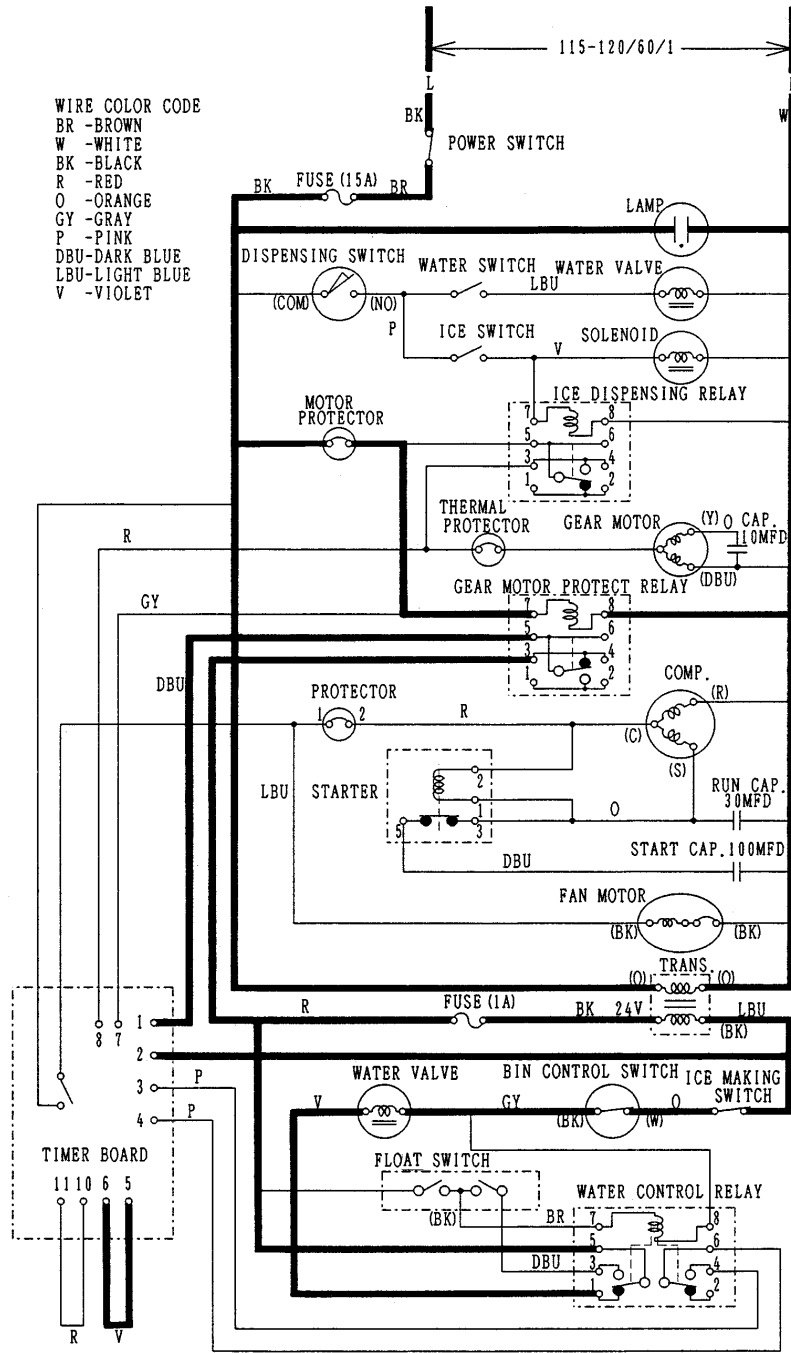

[DCM-240BAB]

WIRING DIAGRAM

- WIRE COLOR CODES
 BR - BROWN
 W - WHITE
 BK - BLACK
 R - RED
 O - ORANGE
 GY - GRAY
 P - PINK
 DBU - DARK BLUE
 LBU - LIGHT BLUE
 V - VIOLET

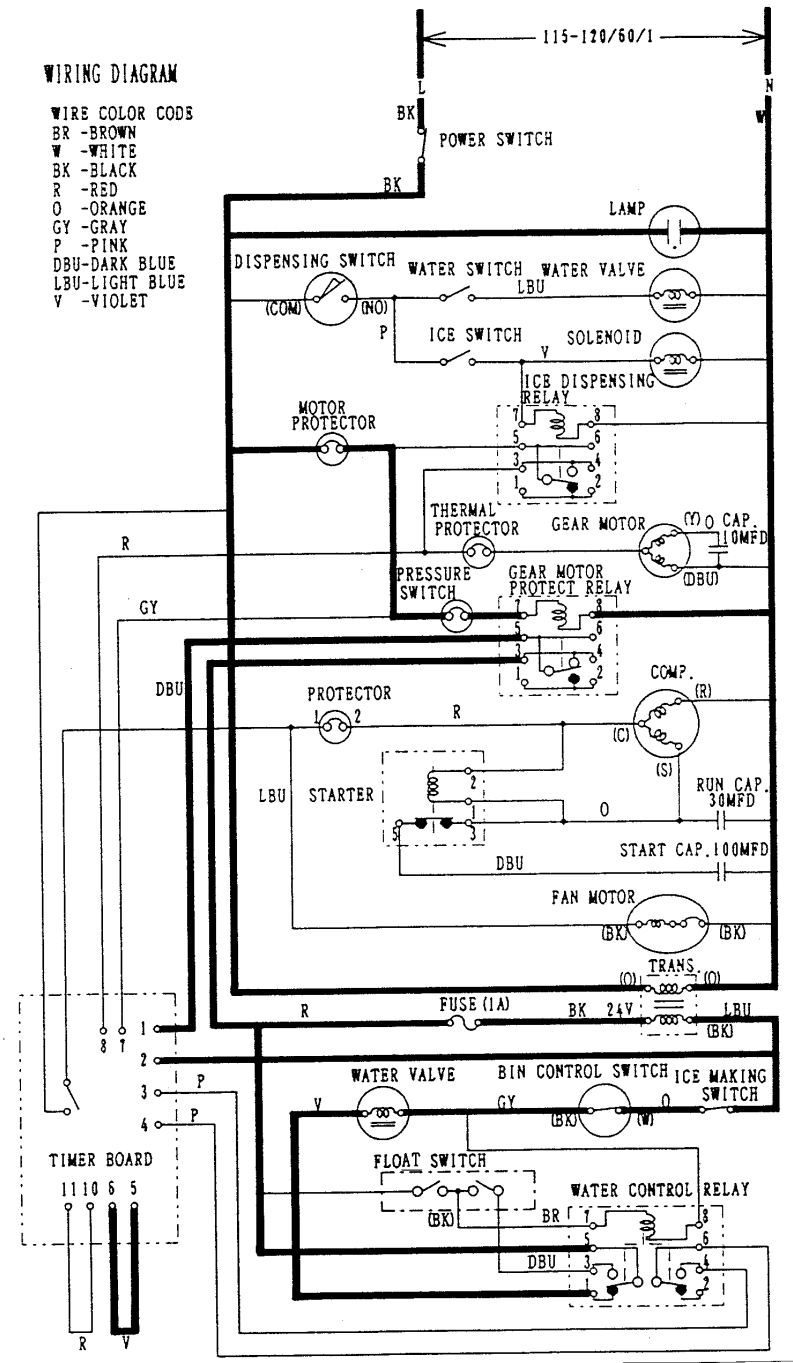

[DCM-240BAE]

[b] When Reservoir has been filled up, Gear Motor starts immediately.

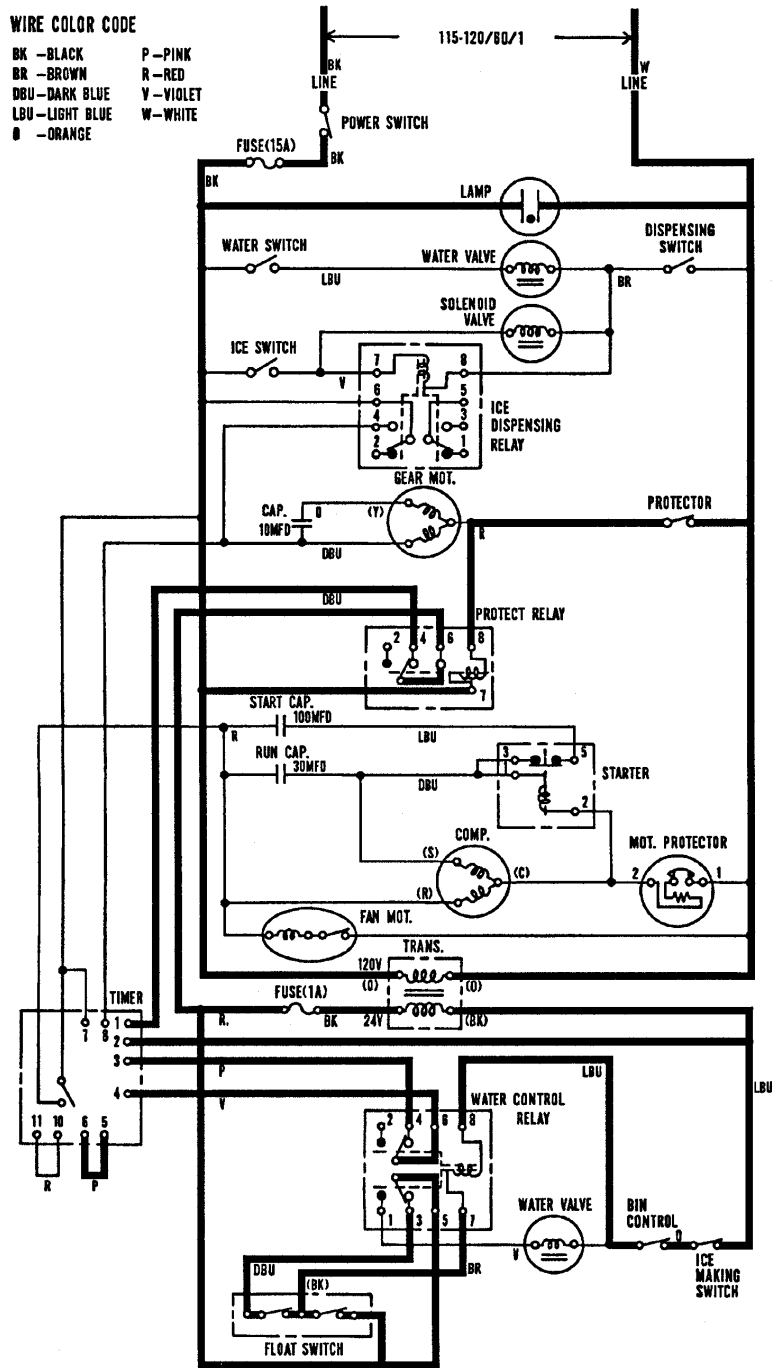

[DCM-240BAA - Step 1: Reservoir filled up.]

WIRE COLOR CODE

- | | |
|------------------|------------|
| BK - BLACK | P - PINK |
| BR - BROWN | R - RED |
| DBU - DARK BLUE | V - VIOLET |
| LBU - LIGHT BLUE | W - WHITE |
| Ø - ORANGE | |

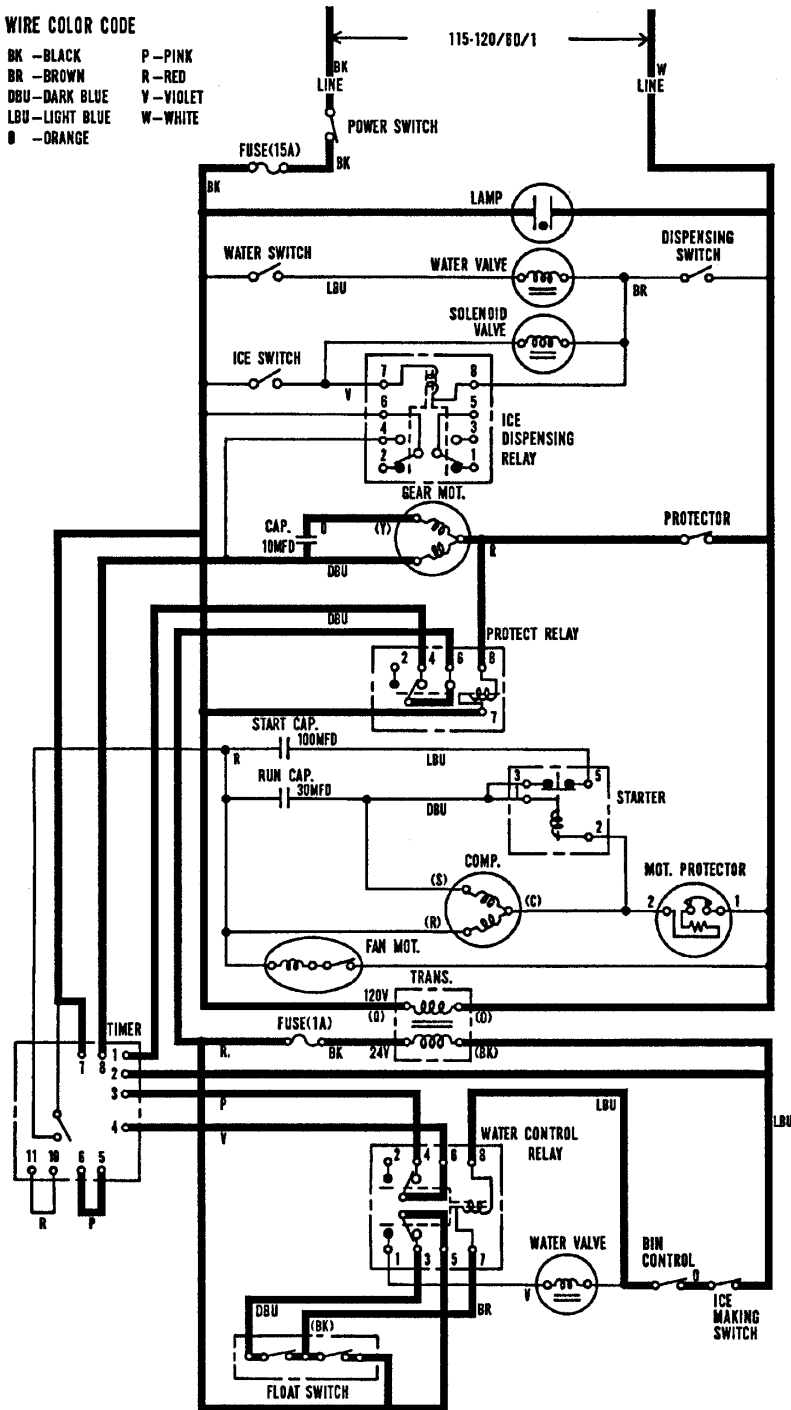

[DCM-240BAA - Step 2: Gear Motor starts.]

WIRE COLOR CODE
 BR - BROWN
 W - WHITE
 BK - BLACK
 R - RED
 O - ORANGE
 GY - GRAY
 P - PINK
 DBU - DARK BLUE
 LBU - LIGHT BLUE
 V - VIOLET

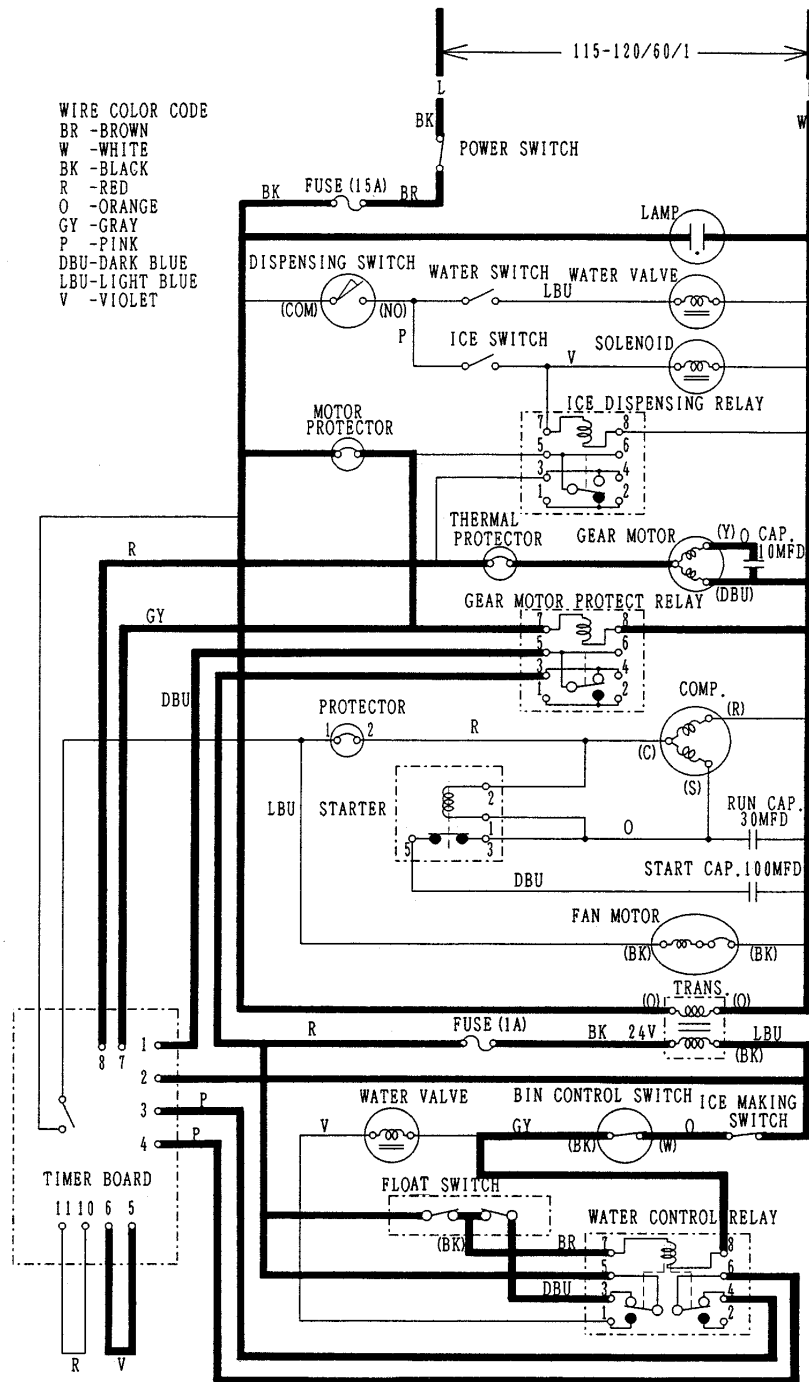

[DCM-240BAB]

WIRING DIAGRAM

- WIRE COLOR CODE**
 BR - BROWN
 W - WHITE
 BK - BLACK
 R - RED
 O - ORANGE
 GY - GRAY
 P - PINK
 DBU - DARK BLUE
 LBU - LIGHT BLUE
 V - VIOLET

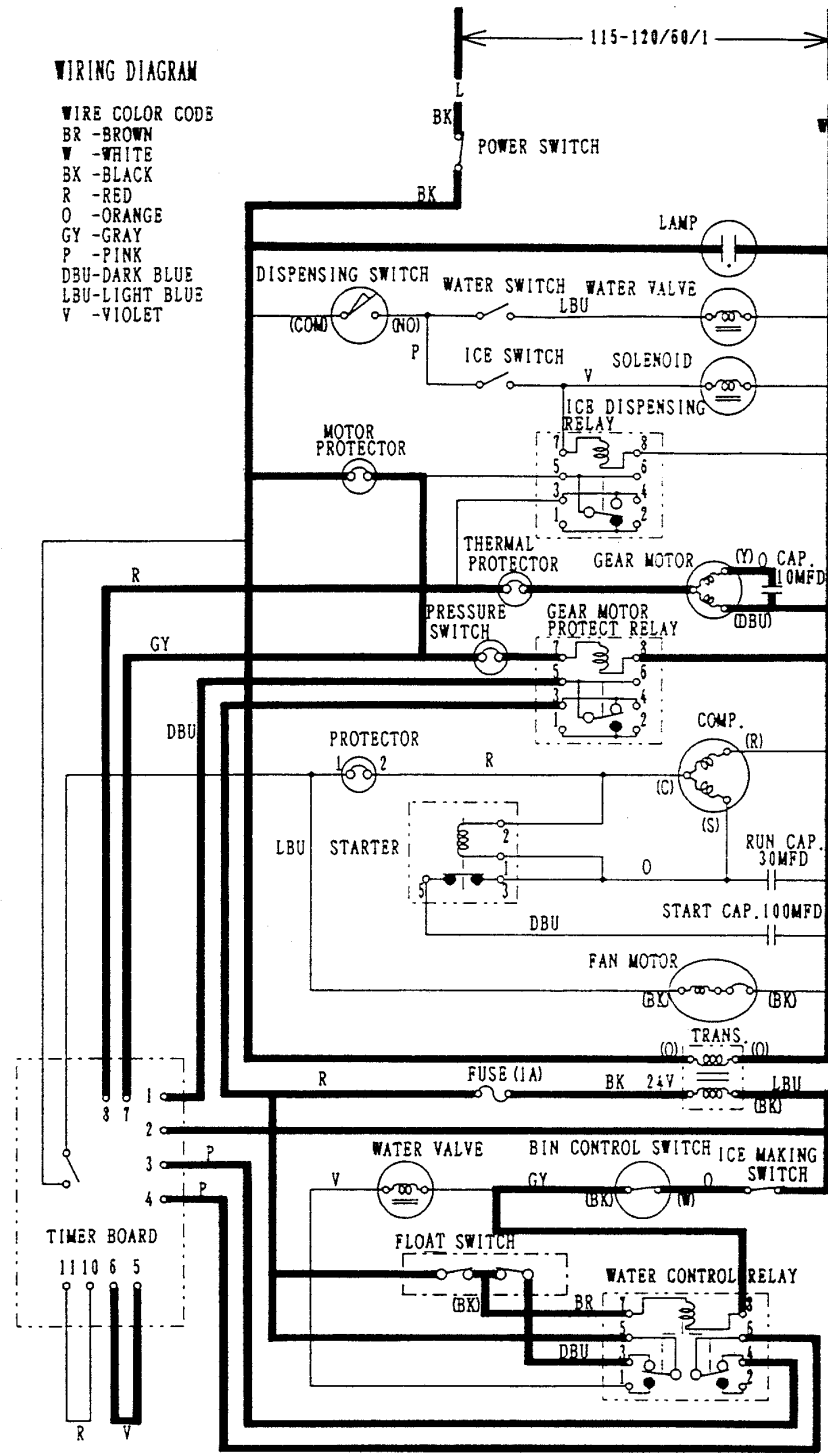

[DCM-240BAE]

[c] Compressor starts about 60 sec. after Gear Motor starts.

WIRE COLOR CODE

- | | |
|------------------|------------|
| BK - BLACK | P - PINK |
| BR - BROWN | R - RED |
| DBU - DARK BLUE | V - VIOLET |
| LBU - LIGHT BLUE | W - WHITE |
| Ø - ORANGE | |

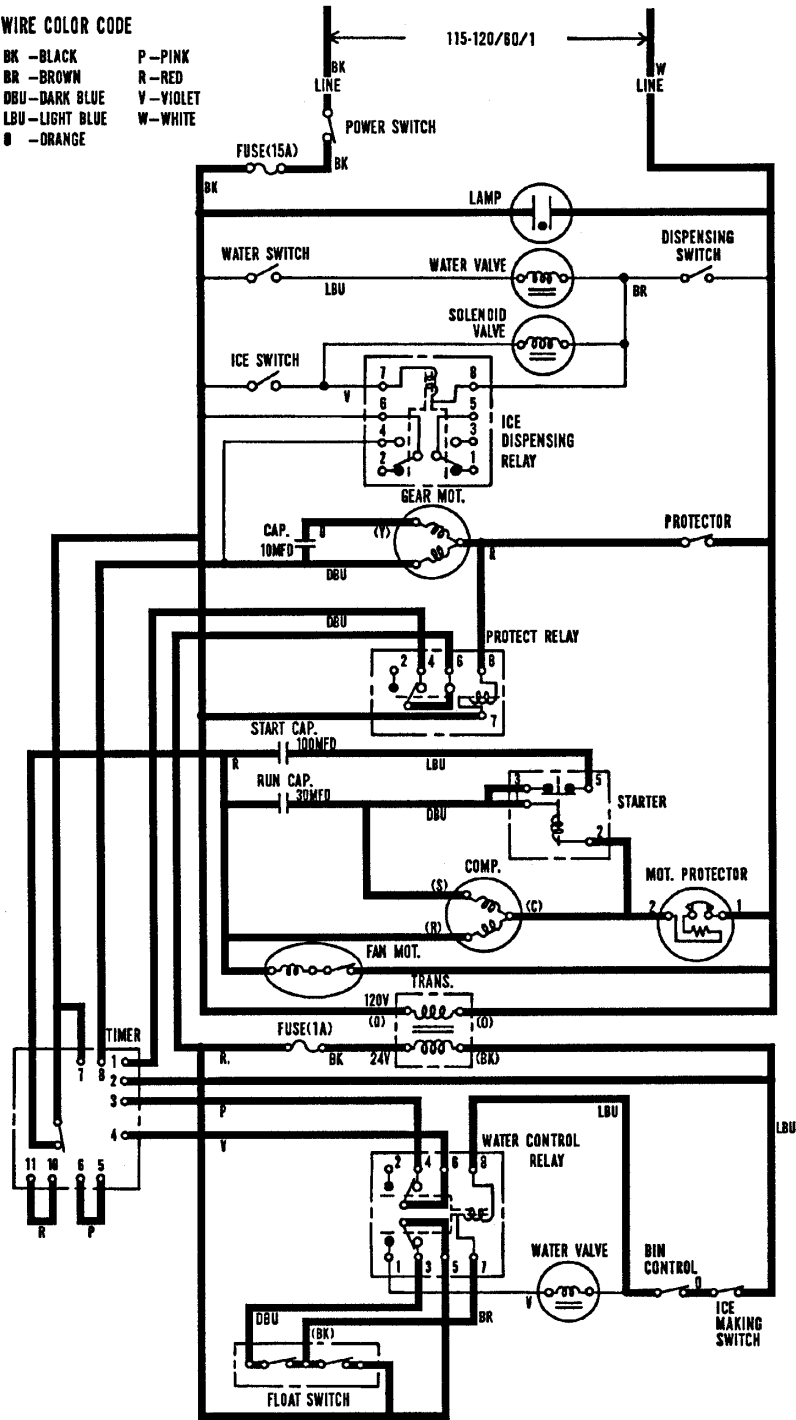

[DCM-240BAA]

WIRE COLOR CODE
 BR - BROWN
 W - WHITE
 BK - BLACK
 R - RED
 O - ORANGE
 GY - GRAY
 P - PINK
 DBU - DARK BLUE
 LBU - LIGHT BLUE
 V - VIOLET

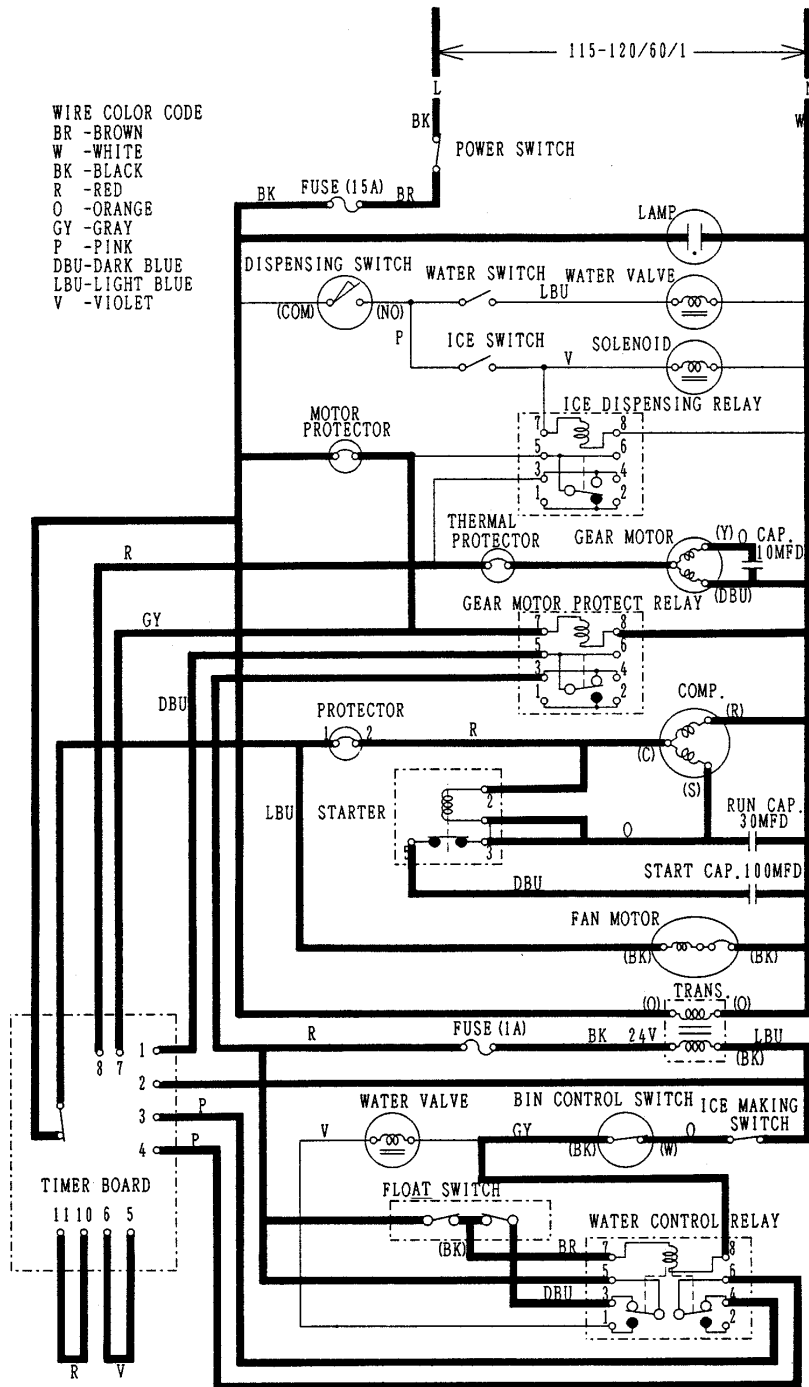

[DCM-240BAB]

WIRING DIAGRAM

WIRE COLOR CODE
 BR - BROWN
 W - WHITE
 BK - BLACK
 R - RED
 O - ORANGE
 GY - GRAY
 P - PINK
 DBU - DARK BLUE
 LBU - LIGHT BLUE
 V - VIOLET

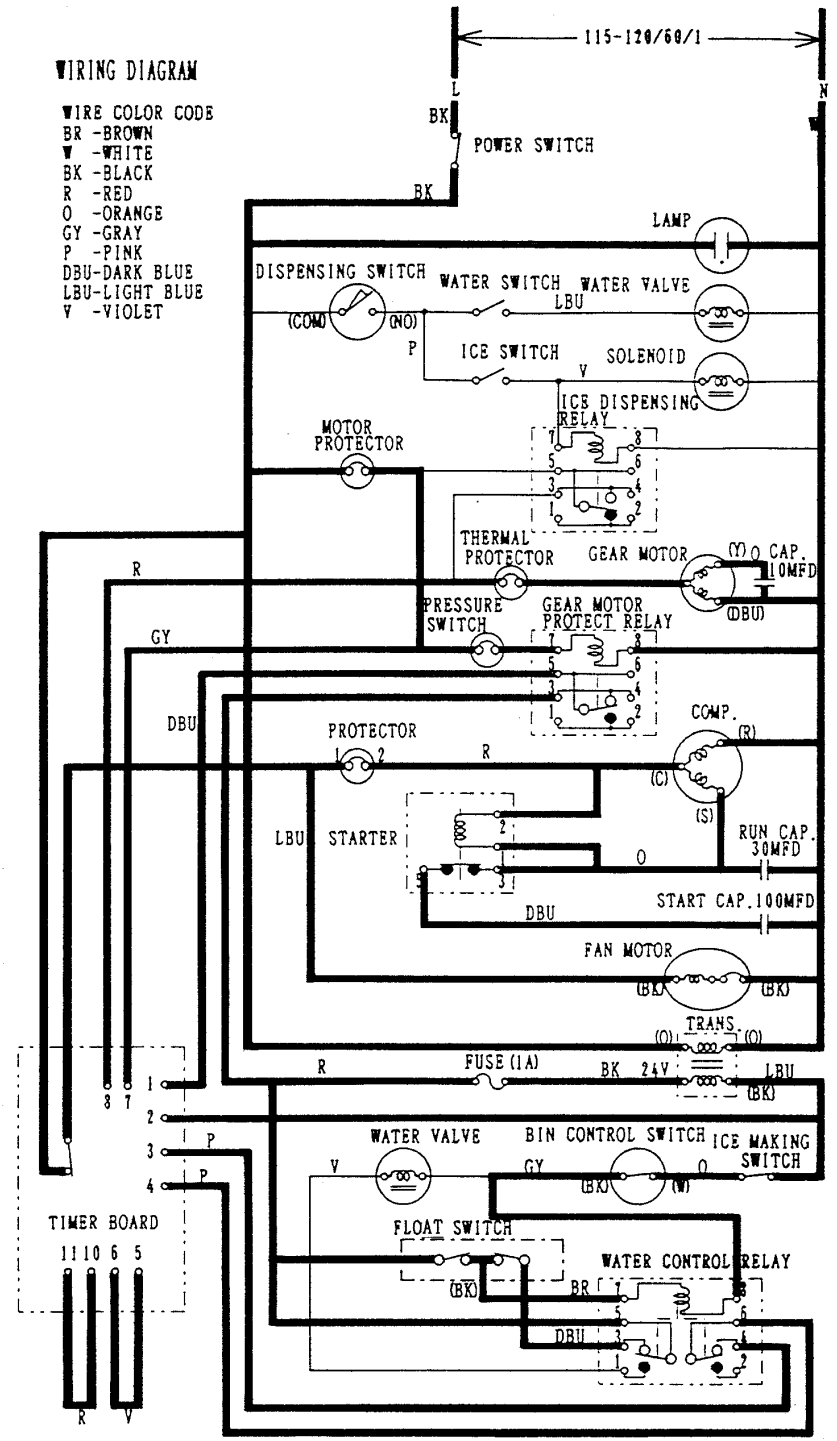

[DCM-240BAE]

[d] Ice making process continues.

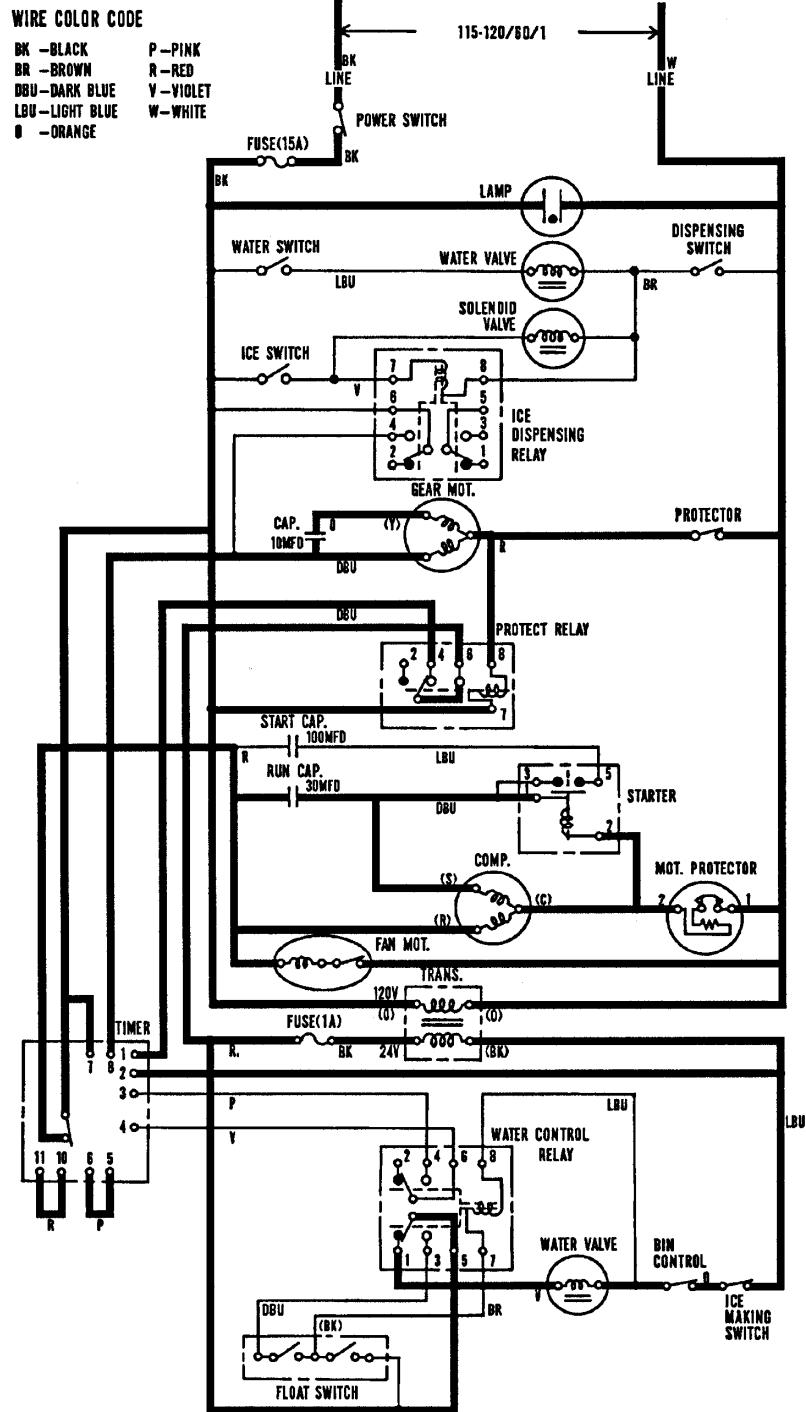

[DCM-240BAA]

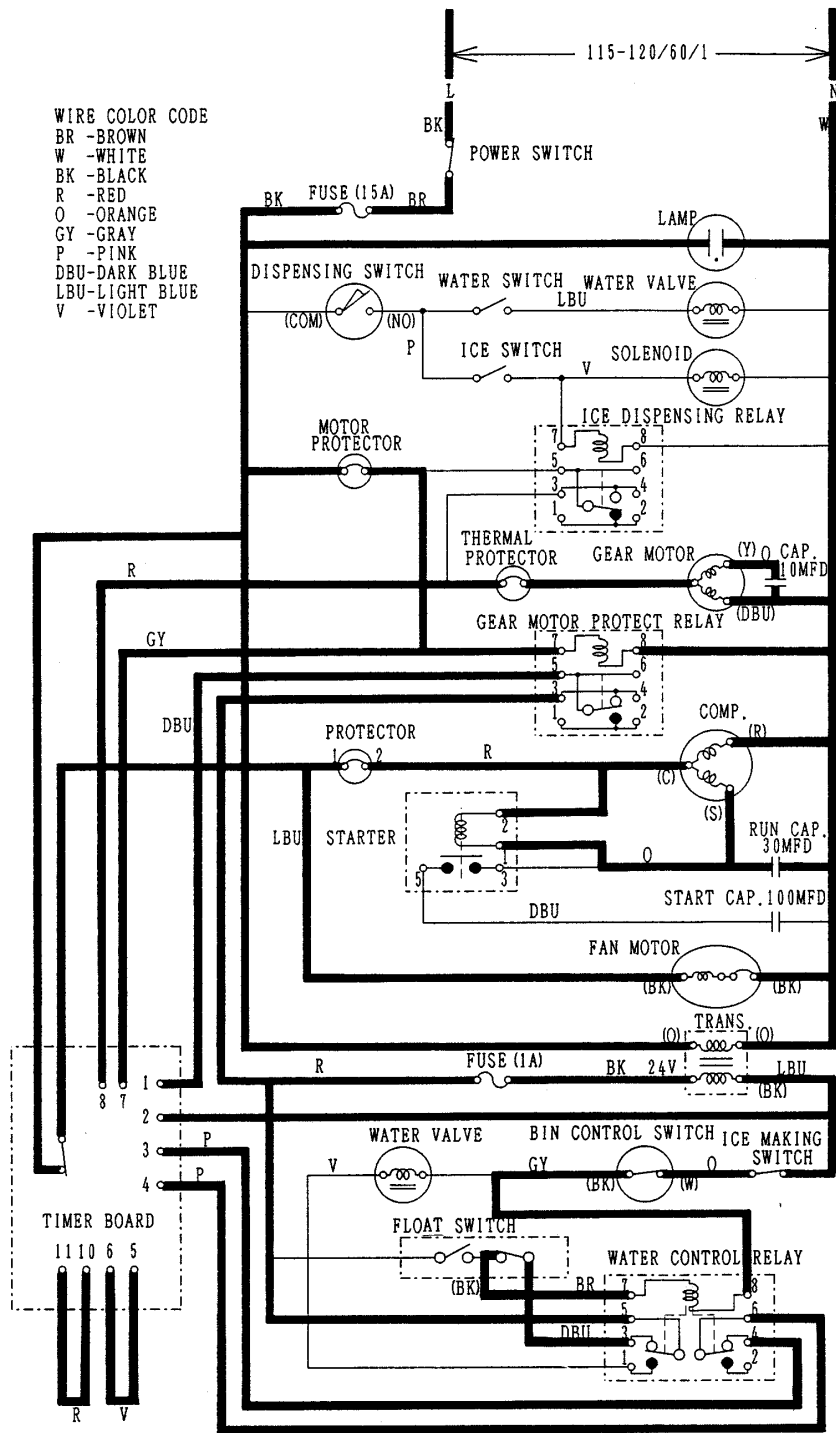

[DCM-240BAB]

WIRING DIAGRAM

WIRE COLOR CODE
 BR - BROWN
 W - WHITE
 BK - BLACK
 R - RED
 O - ORANGE
 GY - GRAY
 P - PINK
 DBU - DARK BLUE
 LBU - LIGHT BLUE
 V - VIOLET

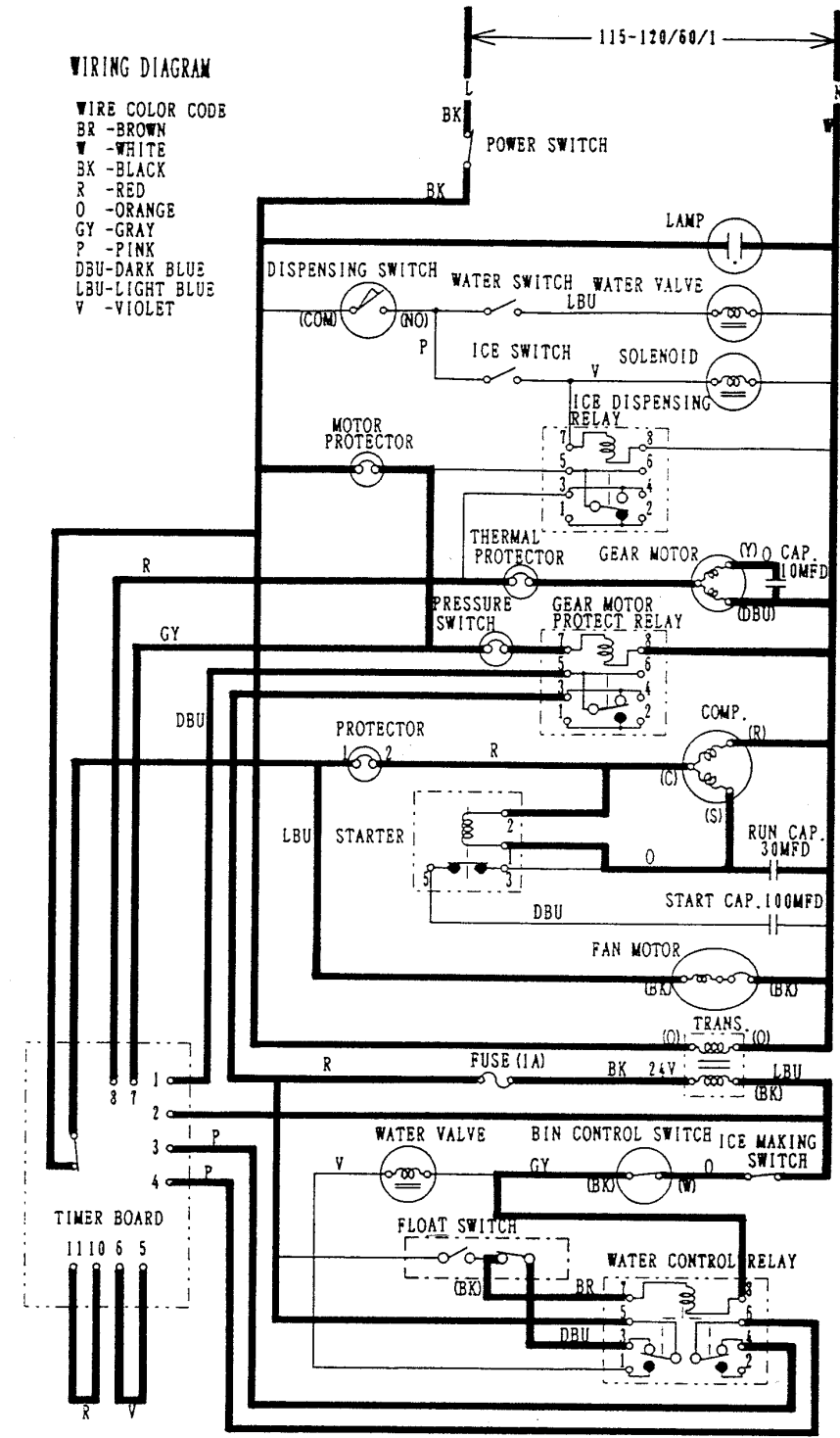

[DCM-240BAE]

[e] Bin Control Switch tripped. Compressor stops about 90 sec. later.

WIRE COLOR CODE

- | | |
|------------------|------------|
| BK - BLACK | P - PINK |
| BR - BROWN | R - RED |
| DBU - DARK BLUE | V - VIOLET |
| LBU - LIGHT BLUE | W - WHITE |
| Ø - ORANGE | |

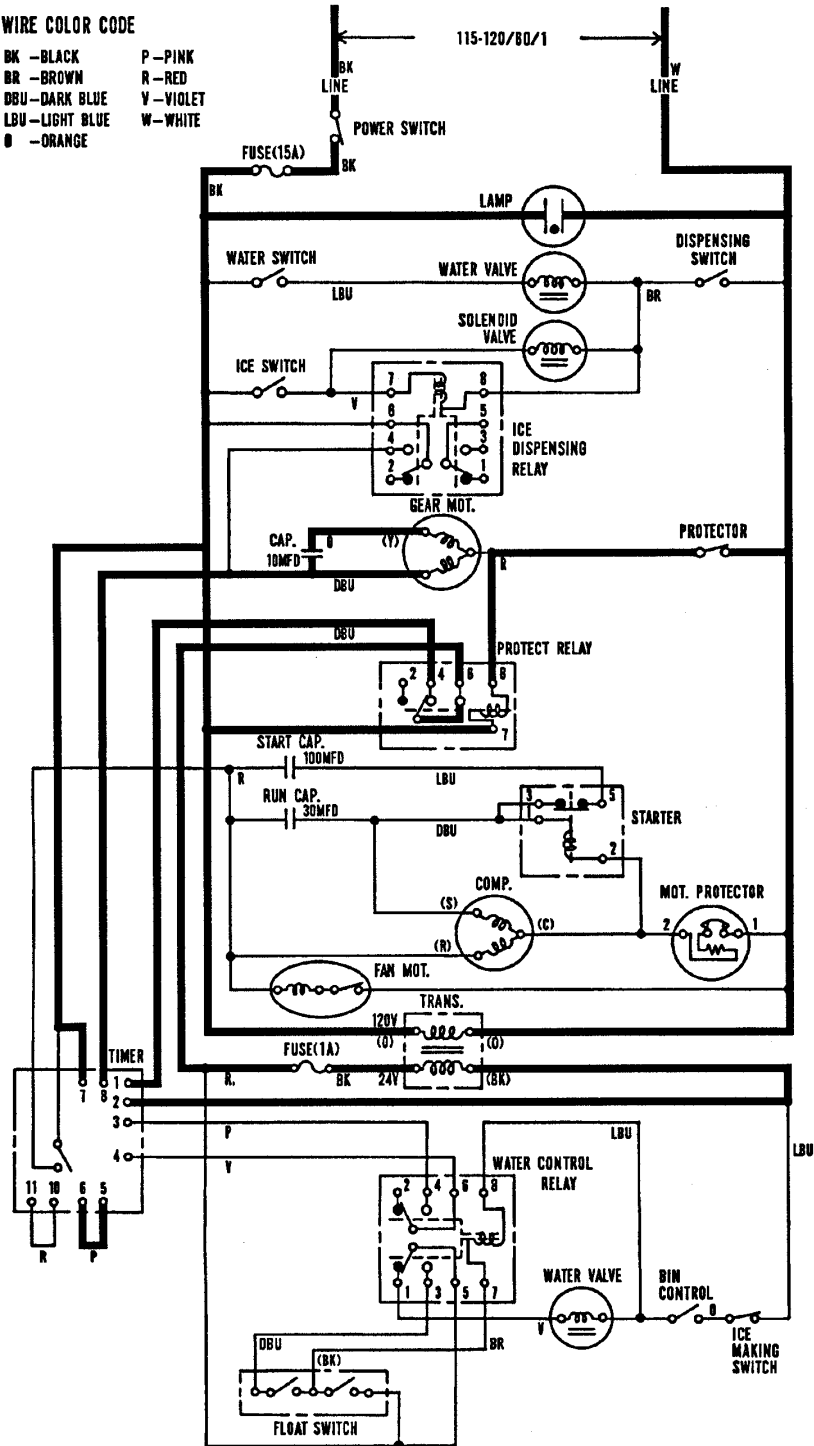

[DCM-240BAA]

WIRE COLOR CODE
 BR - BROWN
 W - WHITE
 BK - BLACK
 R - RED
 O - ORANGE
 GY - GRAY
 P - PINK
 DBU - DARK BLUE
 LBU - LIGHT BLUE
 V - VIOLET

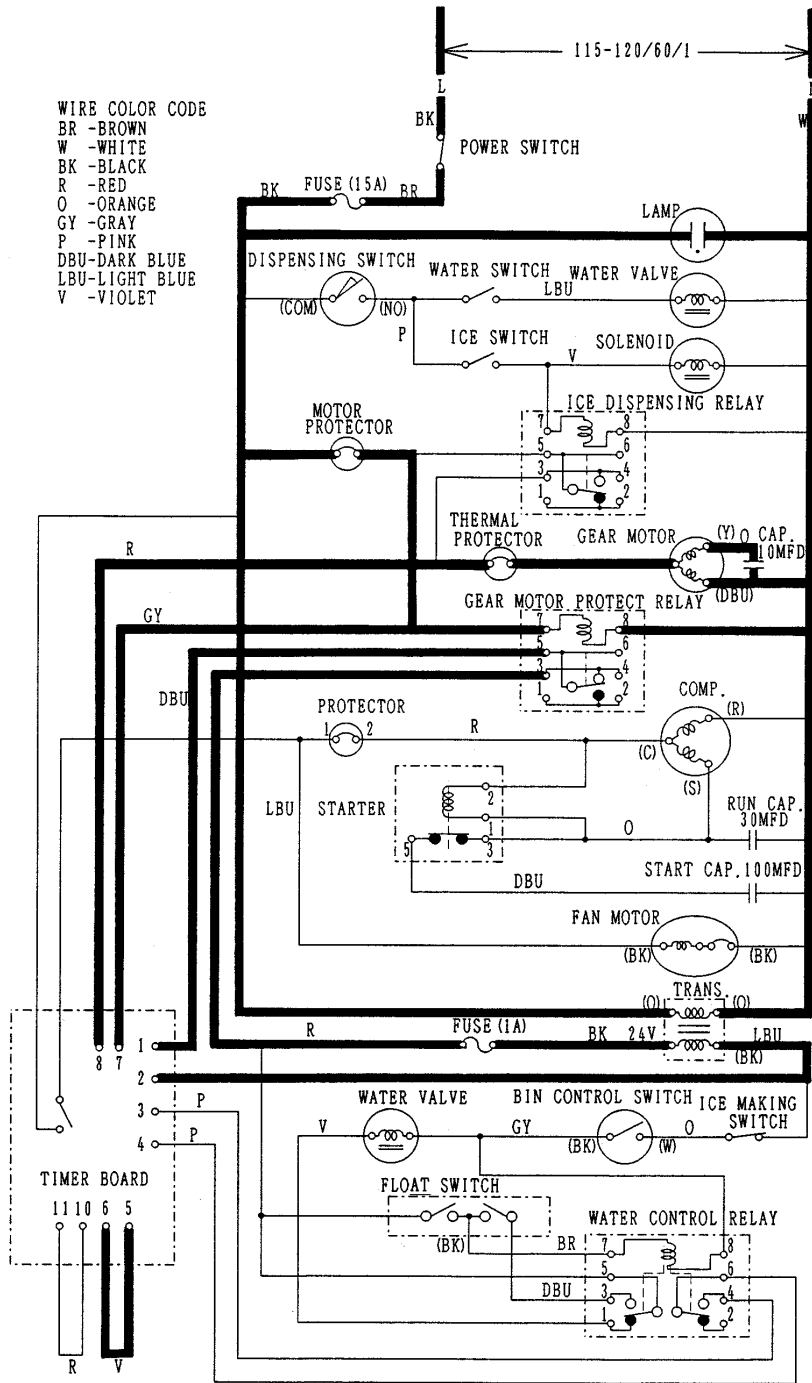

[DCM-240BAB]

WIRING DIAGRAM

- WIRE COLOR CODES**
 BR - BROWN
 W - WHITE
 BK - BLACK
 R - RED
 O - ORANGE
 GY - GRAY
 P - PINK
 DBU - DARK BLUE
 LBU - LIGHT BLUE
 V - VIOLET

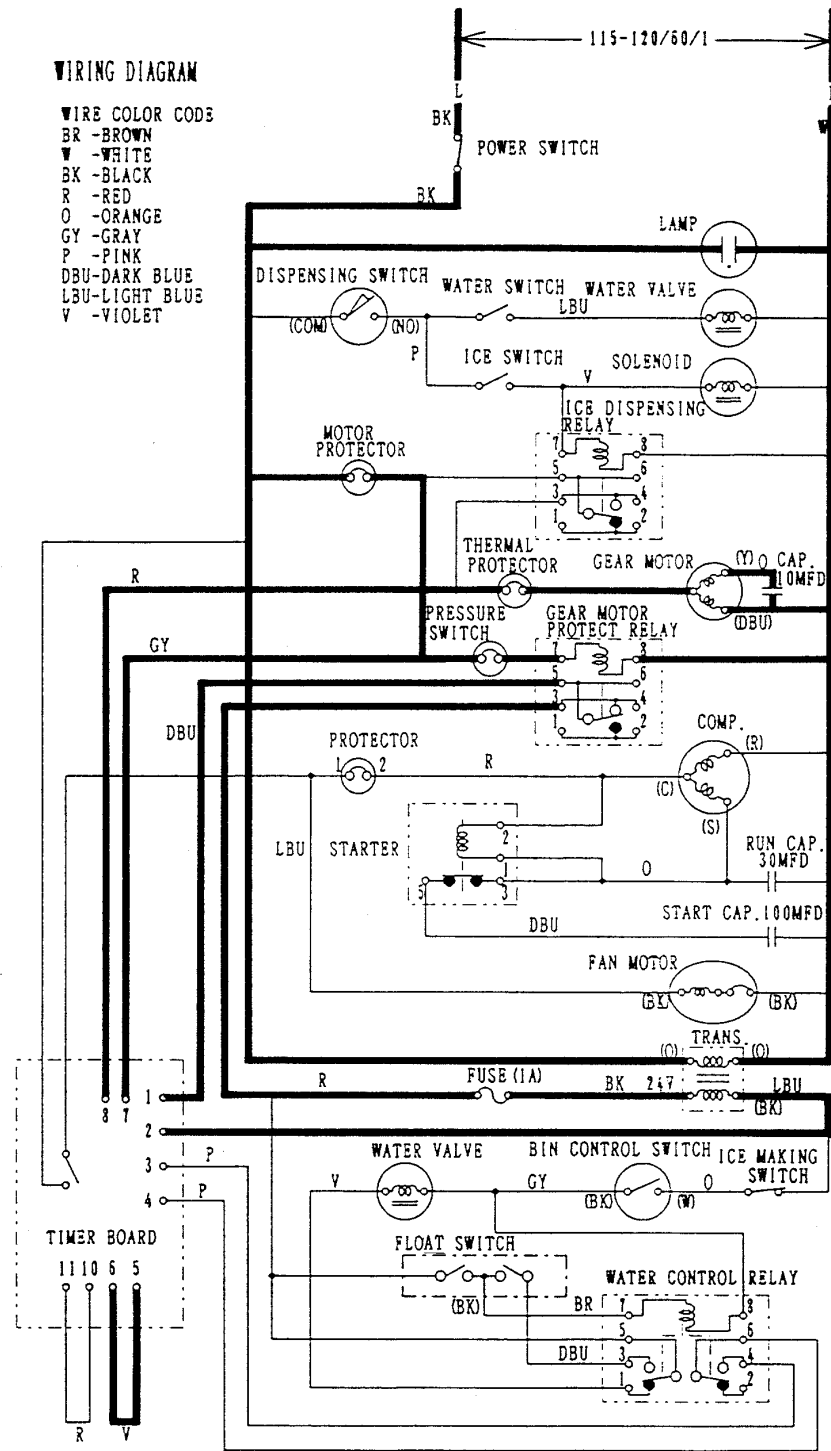

[DCM-240BAE]

[f] Gear Motor stops about 60 sec. after Compressor stops.

WIRE COLOR CODE

- | | |
|------------------|------------|
| BK - BLACK | P - PINK |
| BR - BROWN | R - RED |
| DBU - DARK BLUE | V - VIOLET |
| LBU - LIGHT BLUE | W - WHITE |
| Ø - ORANGE | |

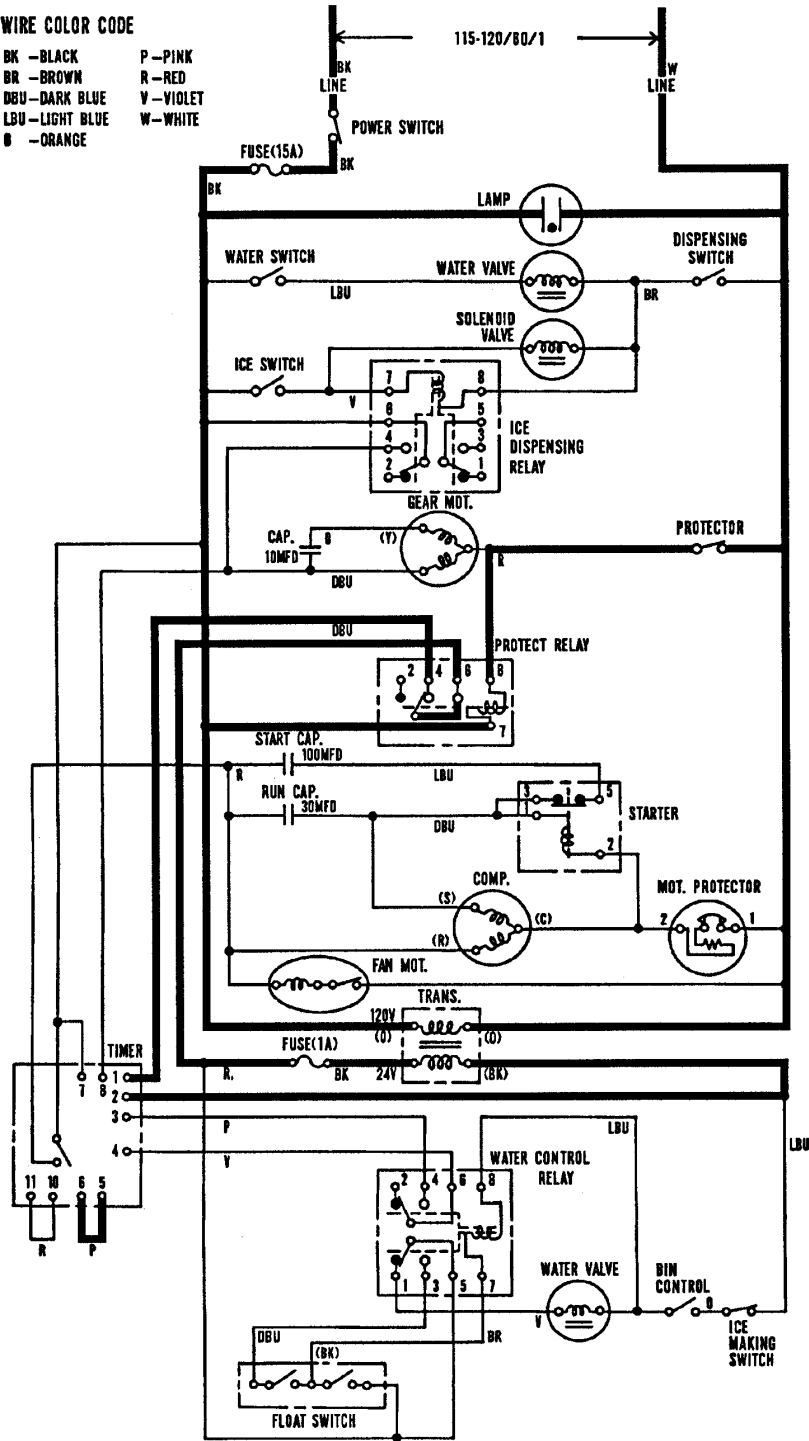

[DCM-240BAA]

WIRE COLOR CODE
 BR - BROWN
 W - WHITE
 BK - BLACK
 R - RED
 O - ORANGE
 GY - GRAY
 P - PINK
 DBU - DARK BLUE
 LBU - LIGHT BLUE
 V - VIOLET

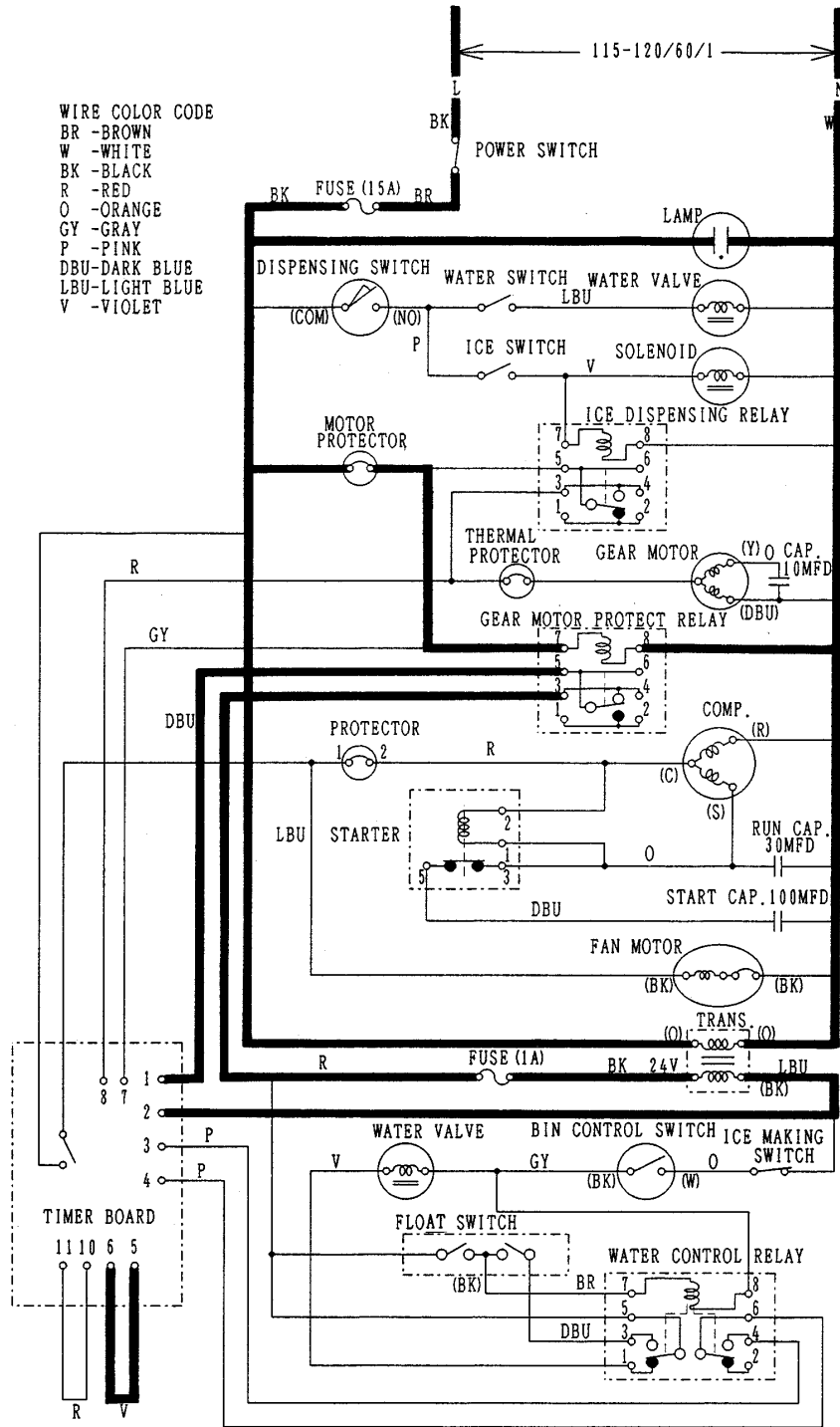

[DCM-240BAB]

WIRING DIAGRAM

- WIRE COLOR CODES
 BR - BROWN
 W - WHITE
 BK - BLACK
 R - RED
 O - ORANGE
 GY - GRAY
 P - PINK
 DBU - DARK BLUE
 LBU - LIGHT BLUE
 V - VIOLET

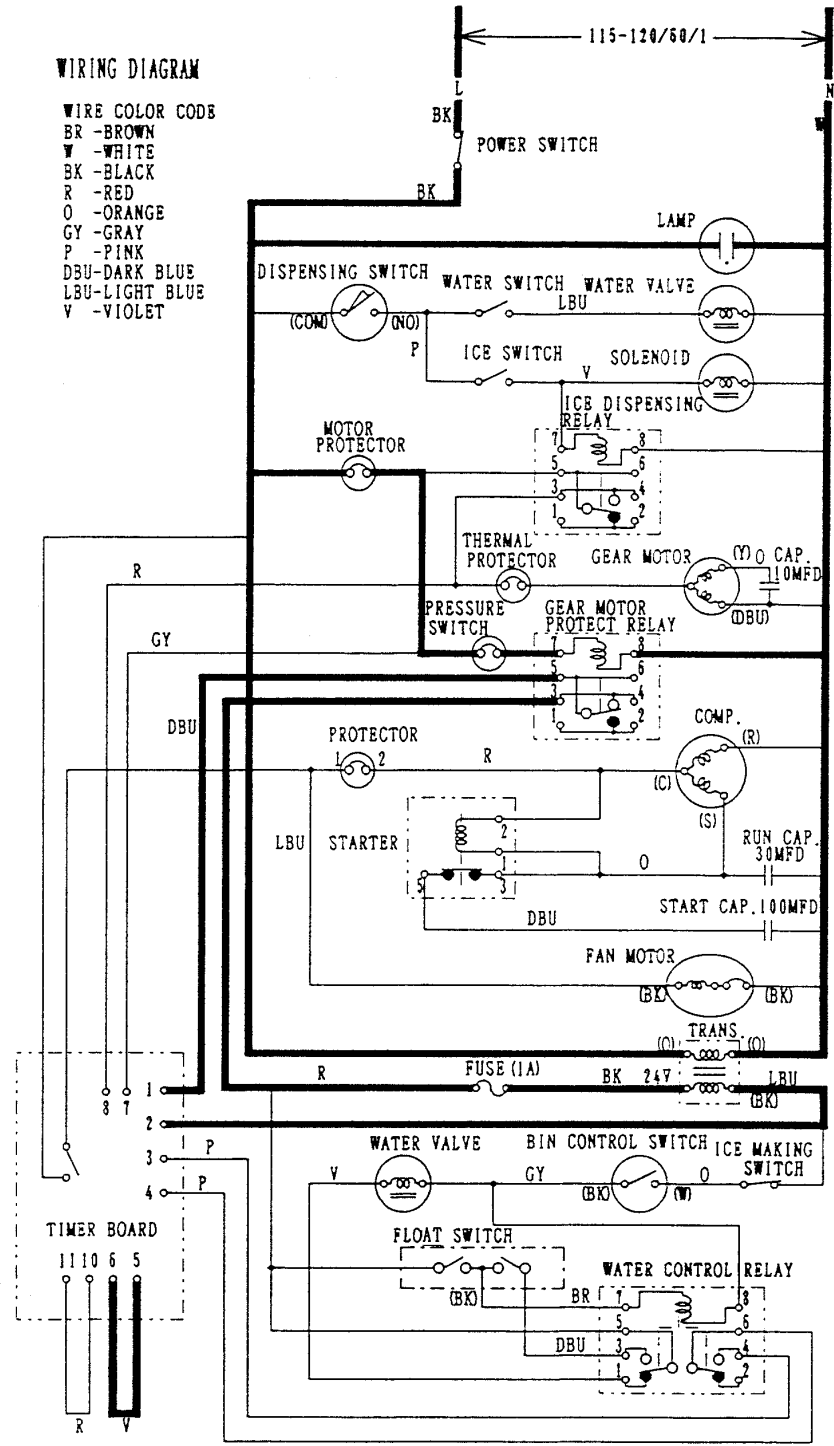

[DCM-240BAE]

[g] Dispensing ice. (Bin Control still tripped.)

WIRE COLOR CODE

- | | |
|------------------|------------|
| BK - BLACK | P - PINK |
| BR - BROWN | R - RED |
| DBU - DARK BLUE | V - VIOLET |
| LBU - LIGHT BLUE | W - WHITE |
| Ø - ORANGE | |

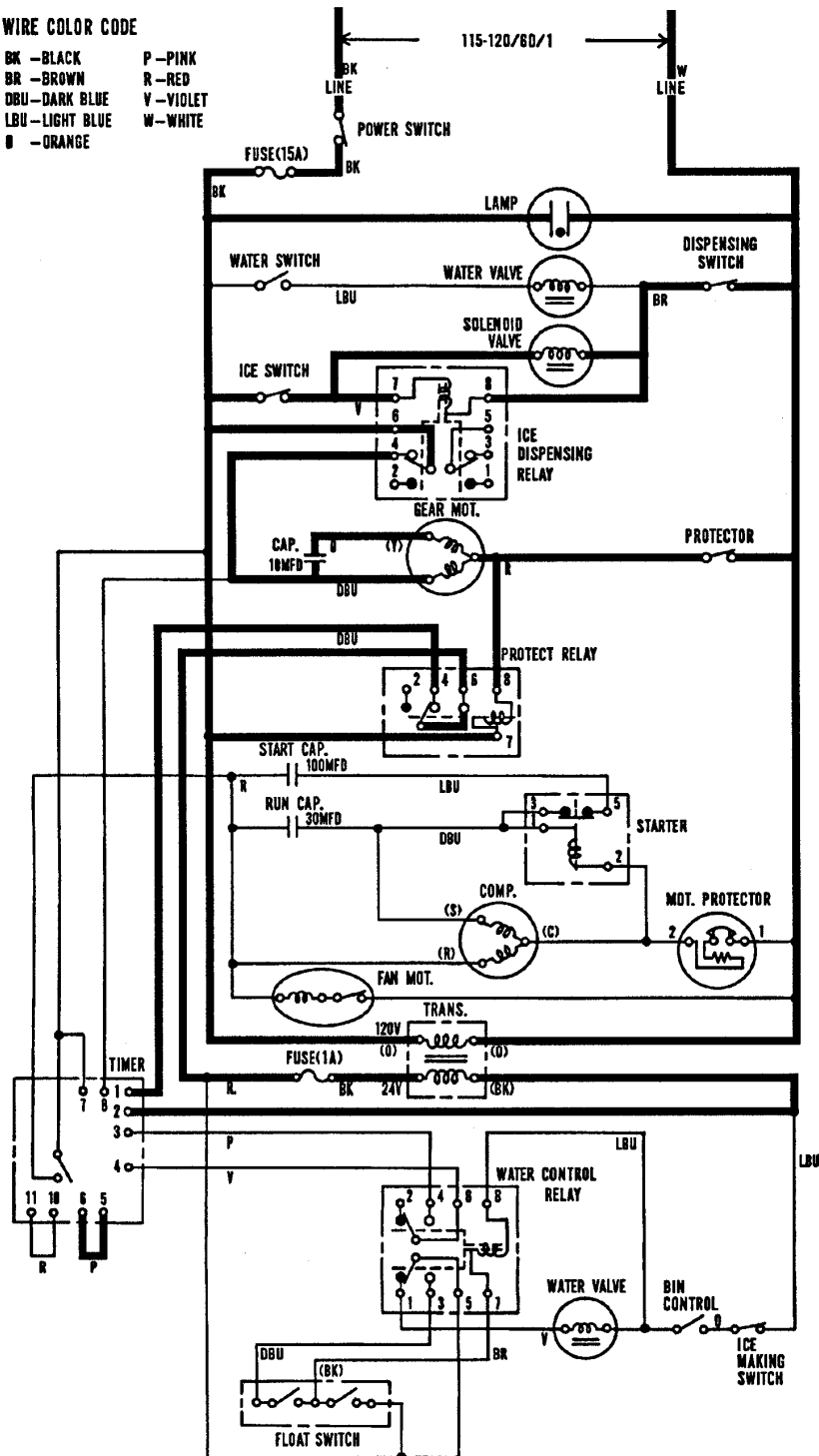

[DCM-240BAA]

WIRE COLOR CODE
 BR - BROWN
 W - WHITE
 BK - BLACK
 R - RED
 O - ORANGE
 GY - GRAY
 P - PINK
 DBU - DARK BLUE
 LBU - LIGHT BLUE
 V - VIOLET

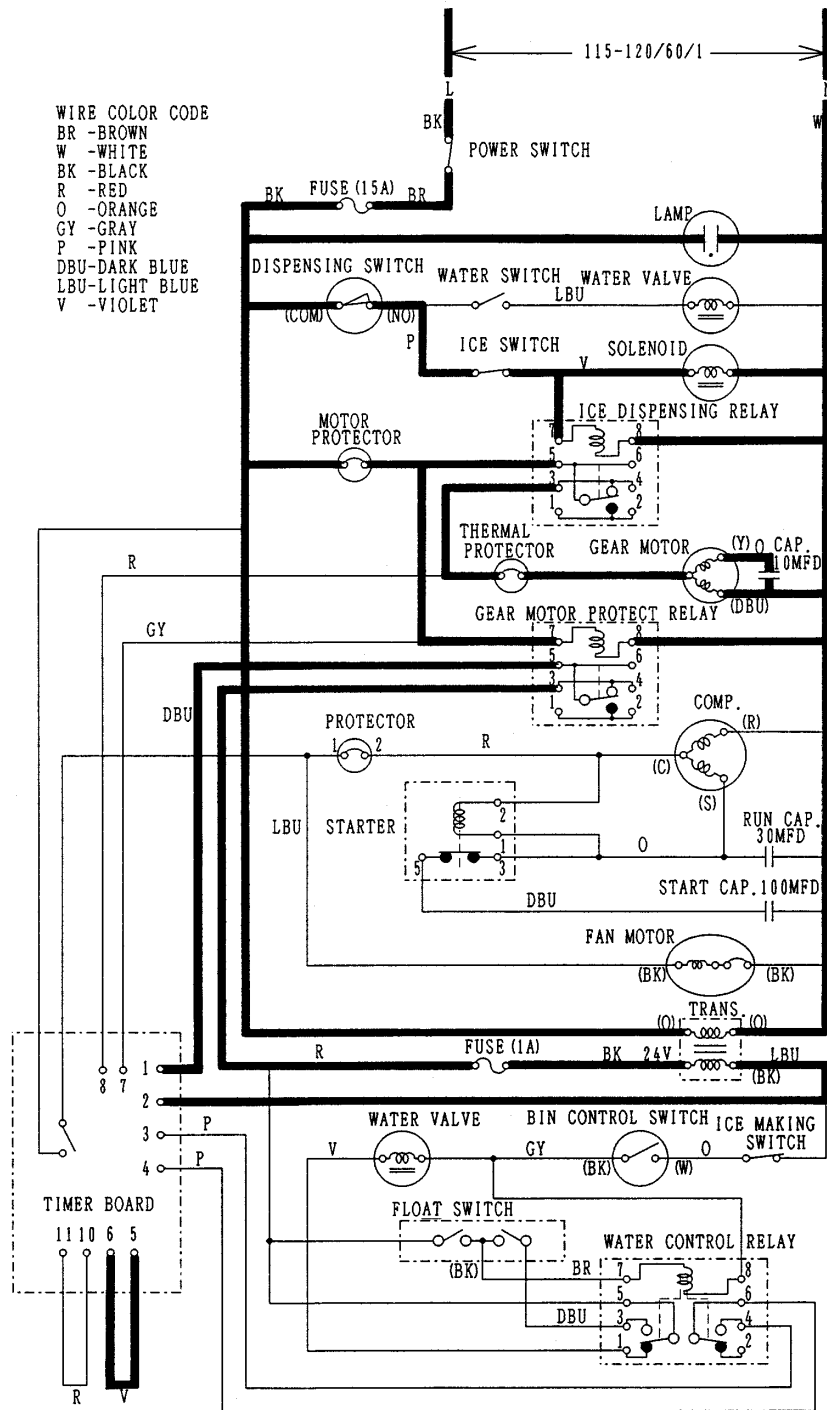

[DCM-240BAB]

WIRING DIAGRAM

WIRE COLOR CODE
 BR - BROWN
 W - WHITE
 BK - BLACK
 R - RED
 O - ORANGE
 GY - GRAY
 P - PINK
 DBU - DARK BLUE
 LBU - LIGHT BLUE
 V - VIOLET

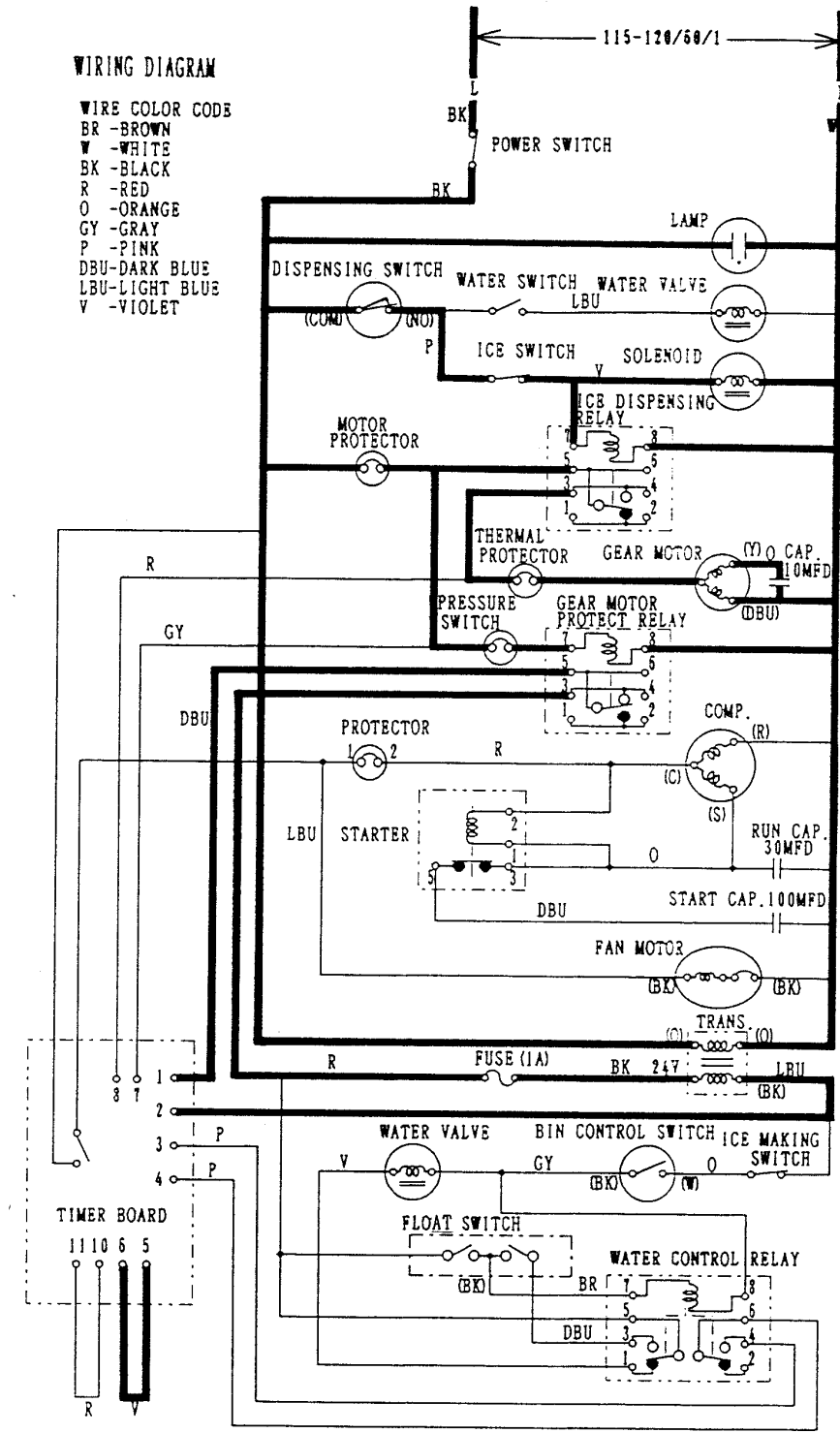

[DCM-240BAE]

[h] Dispensing water. (Bin Control still tripped.)

WIRE COLOR CODE

- | | |
|------------------|------------|
| BK - BLACK | P - PINK |
| BR - BROWN | R - RED |
| DBU - DARK BLUE | V - VIOLET |
| LBU - LIGHT BLUE | W - WHITE |
| O - ORANGE | |

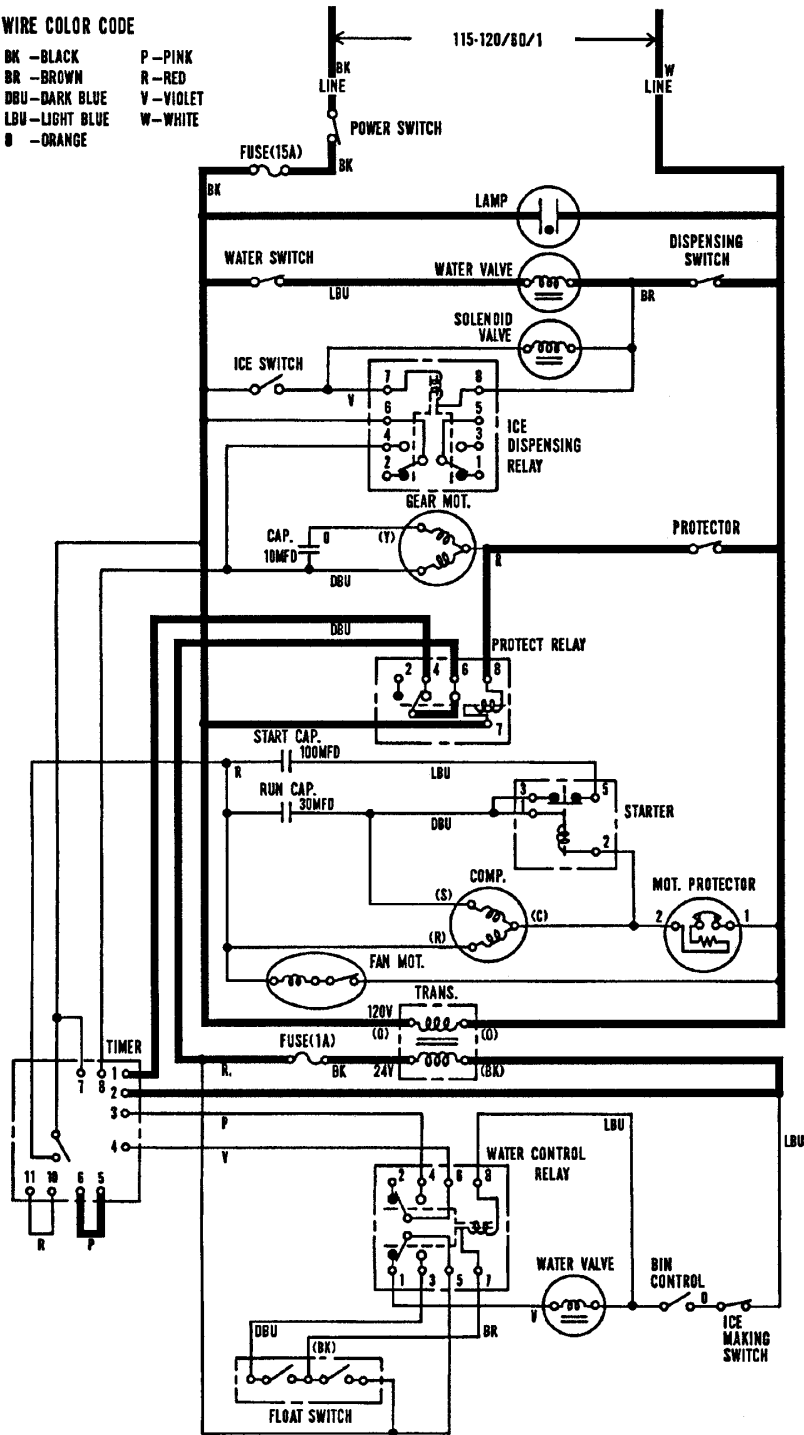

[DCM-240BAA]

WIRE COLOR CODE
 BR - BROWN
 W - WHITE
 BK - BLACK
 R - RED
 O - ORANGE
 GY - GRAY
 P - PINK
 DBU - DARK BLUE
 LBU - LIGHT BLUE
 V - VIOLET

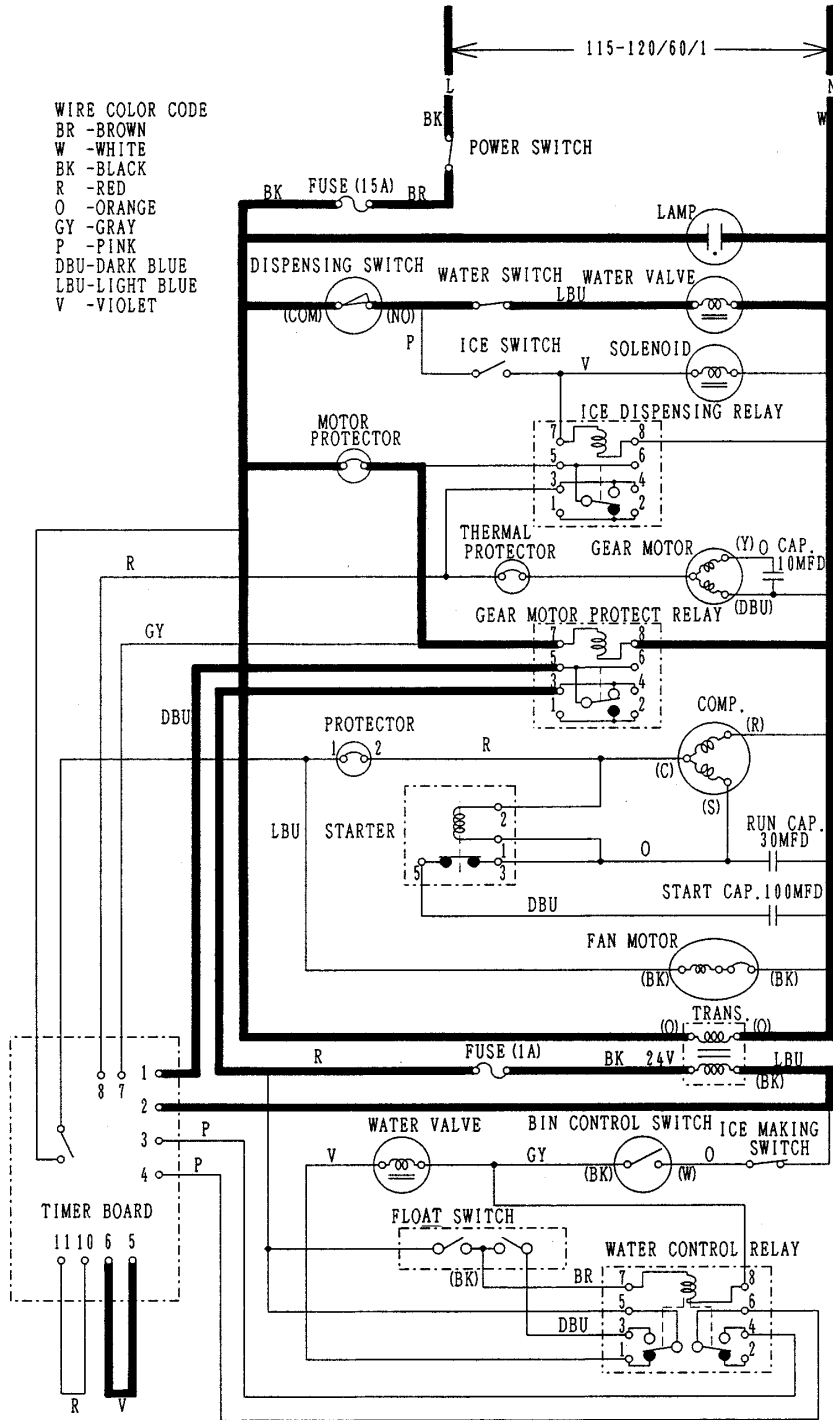

[DCM-240BAB]

WIRING DIAGRAM

- WIRE COLOR CODE
 BR - BROWN
 W - WHITE
 BK - BLACK
 R - RED
 O - ORANGE
 GY - GRAY
 P - PINK
 DBU - DARK BLUE
 LBU - LIGHT BLUE
 V - VIOLET

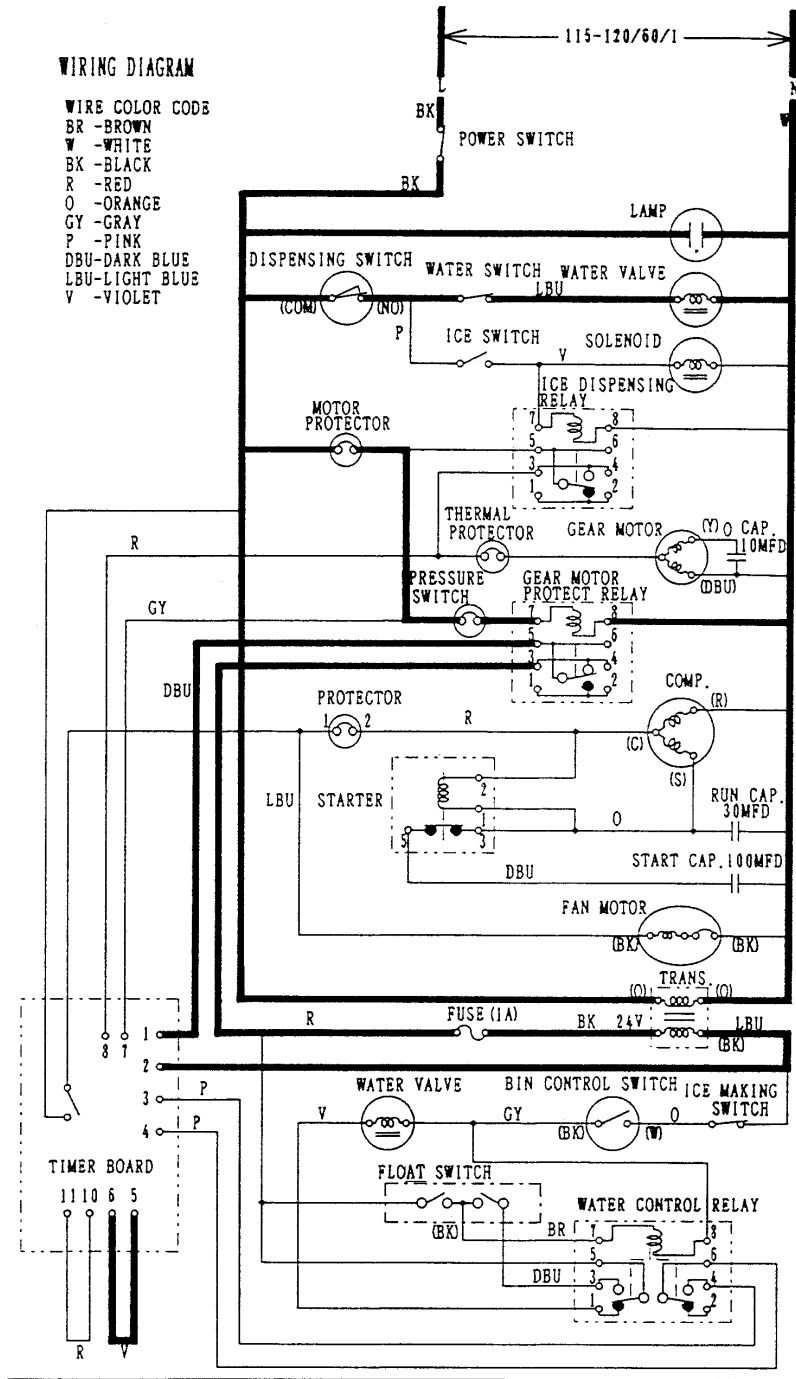

[DCM-240BAE]

[i] When water pressure gets low, black and dark blue leads of Float Switch open. Compressor stops about 90 sec. later, and then Gear Motor stops about 60 sec. after Compressor stops.

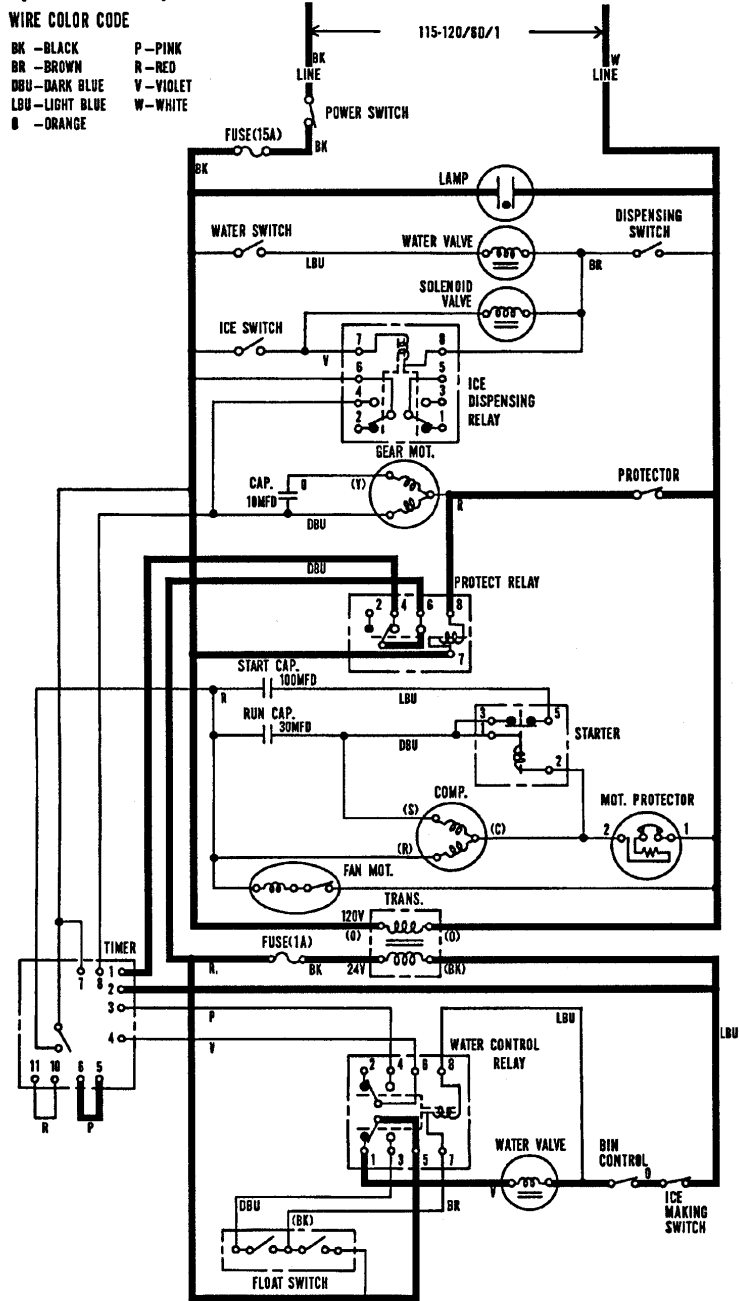

[DCM-240BAA]

WIRE COLOR CODE
 BR - BROWN
 W - WHITE
 BK - BLACK
 R - RED
 O - ORANGE
 GY - GRAY
 P - PINK
 DBU - DARK BLUE
 LBU - LIGHT BLUE
 V - VIOLET

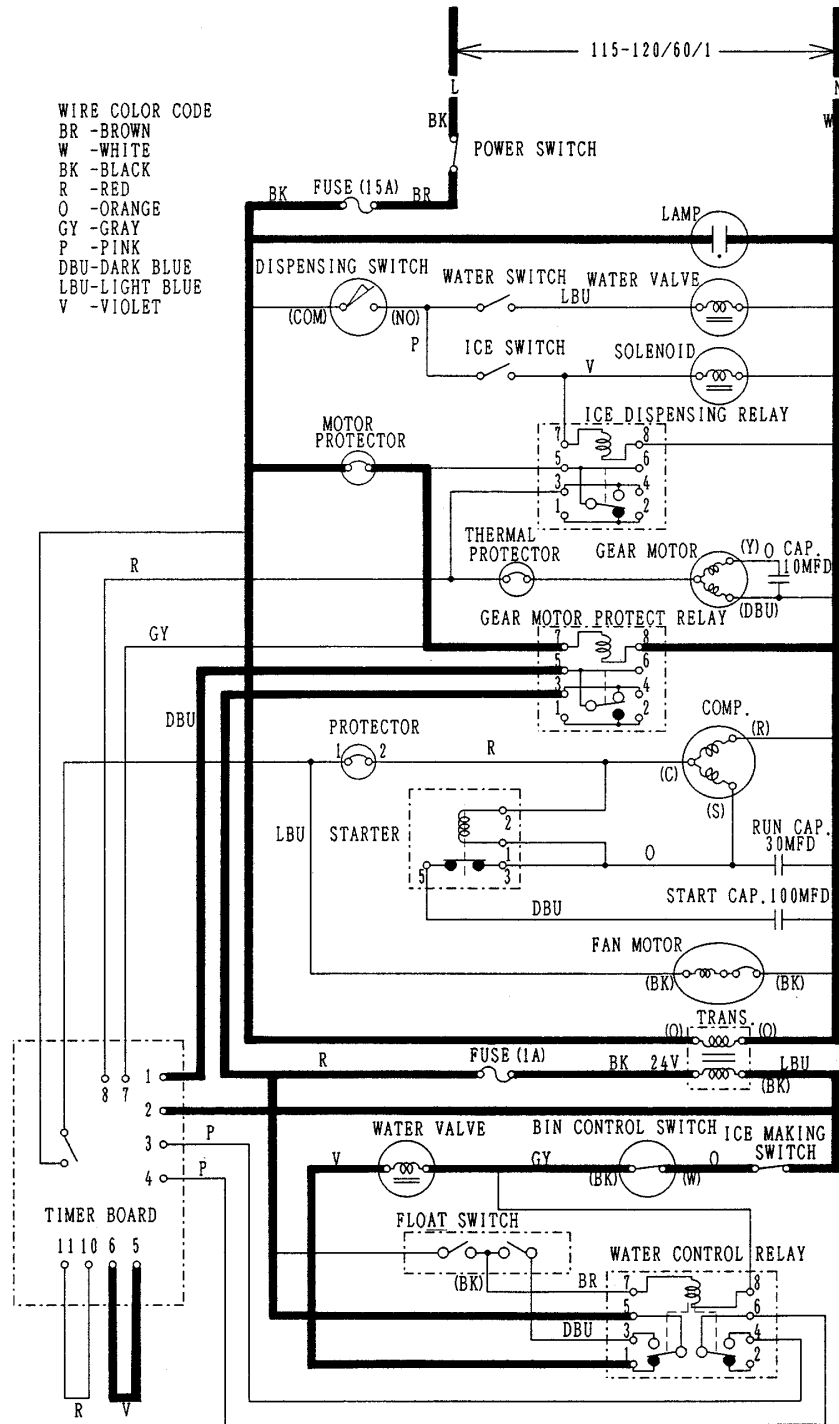

[DCM-240BAB]

WIRING DIAGRAM

- WIRE COLOR CODES**
 BR - BROWN
 W - WHITE
 BK - BLACK
 R - RED
 O - ORANGE
 GY - GRAY
 P - PINK
 DBU - DARK BLUE
 LBU - LIGHT BLUE
 V - VIOLET

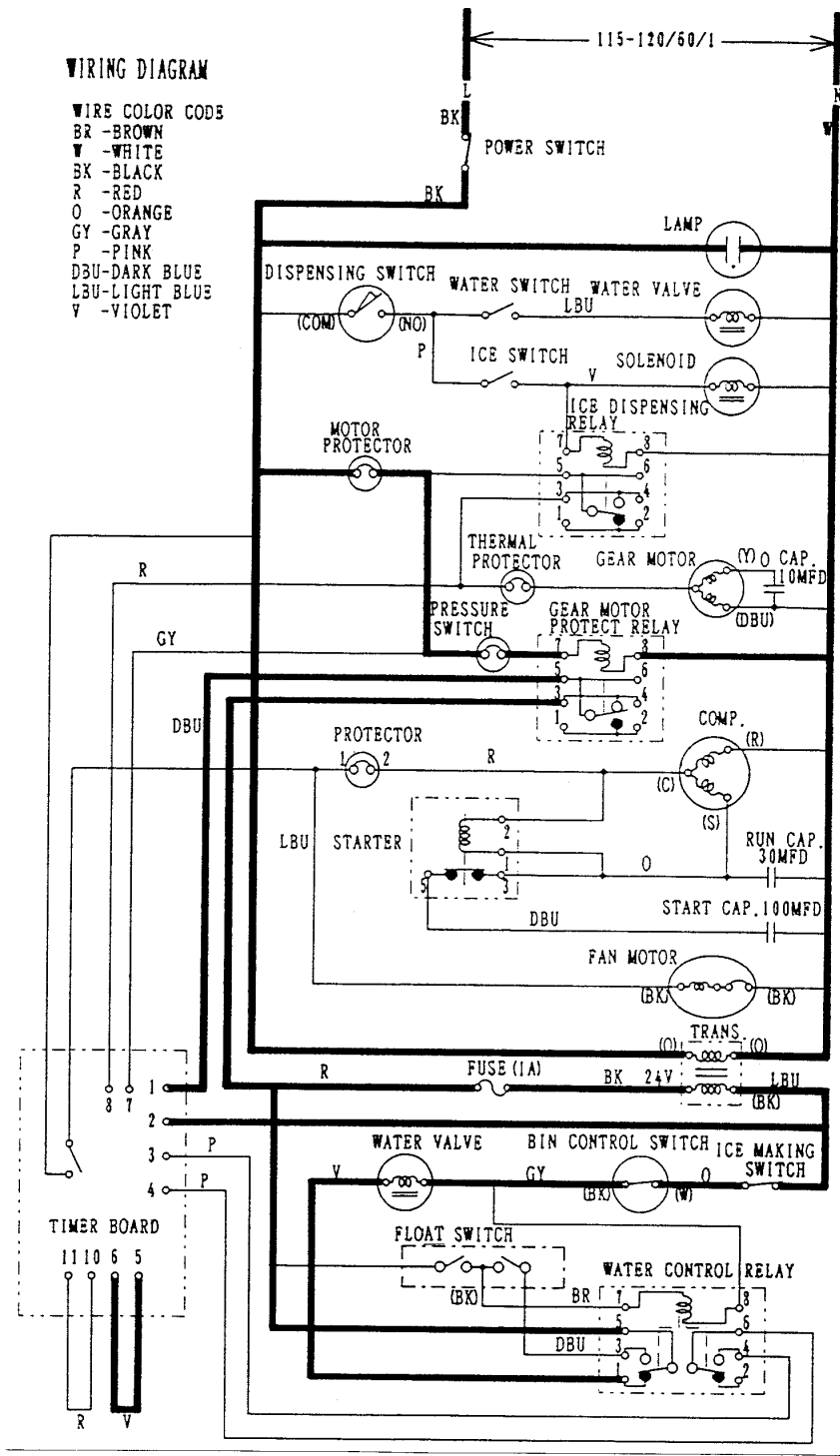

[DCM-240BAE]

4. PERFORMANCE DATA

DCM-240BAA

APPROXIMATE ICE PRODUCTION PER 24 HR.	Ambient	Water Temp. (° F)		
	Temp. (° F)	50	70	90
lbs./day (kg/day)	70	*225(102)	214(97)	209(95)
	80	209(95)	205(93)	203(92)
	90	196(89)	*192(87)	187(85)
	100	170(77)	168(76)	165(75)
APPROXIMATE ELECTRIC CONSUMPTION	70	*625	630	630
	80	630	635	630
	90	630	*640	645
	100	635	645	645
APPROXIMATE WATER CONSUMPTION PER 24 HR.	70	26.9(102)	25.6(97)	25.1(95)
	80	25.1(95)	24.6(93)	24.3(92)
	90	23.5(89)	23.0(87)	22.5(85)
	100	20.3(77)	20.1(76)	19.8(75)
EVAPORATOR OUTLET TEMP.	70	3 (-16.1)	3 (-16.1)	3 (-16.1)
	80	5 (-15)	5 (-15)	5~8 (-15~-13.3)
	90	23~26 (-5 ~-3.3)	19~25 (-7.2~-3.9)	14~17 (-10 ~-8.3)
	100	32 (0)	32 (0)	28 (-2.2)
HEAD PRESSURE	70	101(7.1)	108(7.6)	107(7.5)
	80	121(8.5)	122(8.6)	121(8.5)
	90	134(9.4)	131(9.2)	135(9.5)
	100	157(11.0)	157(11.0)	157(11.0)
TOTAL HEAT OF REJECTION		3980 BTU/h (AT 90 ° /WT 70 ° F)		

Note: The data without *marks should be used for reference.

DCM-240BAB

APPROXIMATE ICE PRODUCTION PER 24 HR.	Ambient	Water Temp. (° F)		
	Temp. (° F)	50	70	90
lbs./day (kg/day)	70	*225(102)	214(97)	209(95)
	80	209(95)	205(93)	203(92)
	90	196(89)	*192(87)	187(85)
	100	170(77)	168(76)	165(75)
APPROXIMATE ELECTRIC CONSUMPTION	70	*625	630	630
	80	630	635	630
	90	630	*640	645
	100	635	645	645
APPROXIMATE WATER CONSUMPTION PER 24 HR.	70	26.9(102)	25.6(97)	25.1(95)
	80	25.1(95)	24.6(93)	24.3(92)
	90	23.5(89)	23.0(87)	22.5(85)
	100	20.3(77)	20.1(76)	19.8(75)
EVAPORATOR OUTLET TEMP.	70	3 (-16.1)	3 (-16.1)	3 (-16.1)
	80	5 (-15)	5 (-15)	5~8 (-15~-13.3)
	90	23~26 (-5 ~-3.3)	19~25 (-7.2~-3.9)	14~17 (-10 ~-8.3)
	100	32 (0)	32 (0)	28 (-2.2)
HEAD PRESSURE	70	101(7.1)	108(7.6)	107(7.5)
	80	121(8.5)	122(8.6)	121(8.5)
	90	134(9.4)	131(9.2)	135(9.5)
	100	157(11.0)	157(11.0)	157(11.0)
TOTAL HEAT OF REJECTION	3980 BTU/h (AT 90° /WT 70° F)			

Note: The data without *marks should be used for reference.

DCM-240BAE

APPROXIMATE ICE PRODUCTION PER 24 HR.	Ambient	Water Temp. (° F)		
	Temp. (° F)	50	70	90
lbs./day (kg/day)	70	* 290(131)	280(127)	270(122)
	80	270(122)	250(113)	230(104)
	90	240(108)	* 230(104)	200 (90)
	100	200 (90)	180 (82)	165 (75)
APPROXIMATE ELECTRIC CONSUMPTION	70	* 740	750	750
	80	760	760	760
	90	780	* 770	780
	100	800	810	820
APPROXIMATE WATER CONSUMPTION PER 24 HR.	70	34.6(131)	33.5(127)	32.2(122)
	80	32.2(122)	29.8(113)	27.5(104)
	90	28.5(108)	27.5(104)	23.8 (90)
	100	23.8 (90)	21.7 (82)	19.8 (75)
EVAPORATOR OUTLET TEMP.	70	14(-9.6)	14(-9.6)	14.5(-9.7)
	80	16(-8.9)	16(-8.9)	16(-8.9)
	90	17.6(-8.0)	16.9(-8.4)	16(-8.5)
	100	19.4(-7.0)	19.4(-7.0)	18.5(-7.5)
HEAD PRESSURE	70	221(15.6)	227(16.0)	231(16.3)
	80	255(18.0)	257(18.1)	258(18.2)
	90	285(20.1)	282(19.9)	291(20.5)
	100	324(22.8)	320(22.5)	317(22.3)
SUCTION PRESSURE	70	28(2.0)	28(2.0)	30(2.1)
	80	30(2.1)	30(2.1)	30(2.1)
	90	31(2.2)	31(2.2)	31(2.2)
	100	34(2.4)	34(2.4)	34(2.4)
TOTAL HEAT OF REJECTION		BTU/h (AT 90° /WT 70° F)		

Note: The data without *marks should be used for reference.

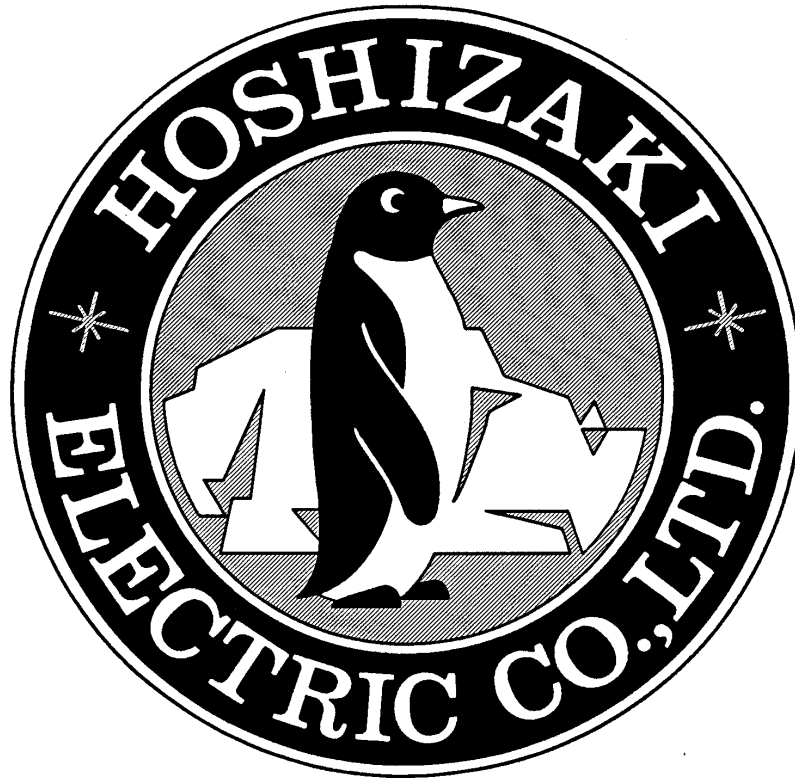

**HOSHIZAKI
CUBELET ICE DISPENSER**

**IV.
SERVICE INFORMATION**

CONTENTS

	PAGE
ADJUSTMENT OF COMPONENTS	IV-1
1. ADJUSTMENT OF CONSTANT PRESSURE EXPANSION VALVE	
- EXCEPT DCM-240BAE	IV-1
[a] HOW TO ADJUST	IV-1
[b] SUCTION TEMPERATURE	IV-1
[c] SUCTION PRESSURE	IV-2
SERVICE DIAGNOSIS	IV-3
1. NO ICE PRODUCTION	IV-3
2. LOW ICE PRODUCTION	IV-5
3. FAULTY DISPENSER	IV-6
4. OTHERS	IV-7
REMOVAL AND REPLACEMENT OF COMPONENTS	IV-8
1. SERVICE FOR REFRIGERANT LINES	IV-8
[a] REFRIGERANT RECOVERY	IV-8
[b] EVACUATION AND RECHARGE	IV-8
2. BRAZING	IV-9
3. REMOVAL AND REPLACEMENT OF COMPRESSOR	IV-10
4. REMOVAL AND REPLACEMENT OF DRIER	IV-13
5. REMOVAL AND REPLACEMENT OF CONSTANT PRESSURE EXPANSION VALVE (DCM-240BAA, BAB) AND THERMOSTATIC EXPANSION VALVE (DCM-240BAE)	IV-14
6. REMOVAL AND REPLACEMENT OF PRESSURE SWITCH	
- DCM-240BAE ONLY	IV-15
7. REMOVAL AND REPLACEMENT OF WATER VALVE	IV-16
8. REMOVAL AND REPLACEMENT OF FLOAT SWITCH	IV-17
9. REMOVAL AND REPLACEMENT OF BIN CONTROL SWITCH ASSEMBLY ..	IV-18
10. REMOVAL AND REPLACEMENT OF STORAGE BIN ASSEMBLY	IV-19
11. REMOVAL AND REPLACEMENT OF AGITATOR AND DRIP RING	IV-21
12. REMOVAL AND REPLACEMENT OF EVAPORATOR ASSEMBLY	IV-22

ADJUSTMENT OF COMPONENTS

1. CONSTANT PRESSURE EXPANSION VALVE - EXCEPT DCM-240BAE

Since the Constant Pressure Expansion Valve is factory-adjusted to the ideal setting, no adjustment is required. Should an adjustment be required for some reason, perform the adjustment carefully in compliance with the following procedures.

Note: DCM-240BAE employs an unadjustable Thermostatic Expansion Valve (R22, 27 - 33 PSIG).

[a] HOW TO ADJUST

* The Adjust Screw is visible when the Cap on the end has been removed.

* To increase the refrigerant flow, turn the Adjust Screw clockwise.

* To decrease the refrigerant flow, turn the Adjust Screw counterclockwise.

IMPORTANT

1. Do not turn the Adjust Screw more than 90 degrees.
2. Wait for 2 or 3 minutes from an adjustment to another in order to stabilize the system.

* Adjust carefully in terms of overall ice quality, ice production capacity, ice dispenser friction sound and Compressor heating conditions.

[b] SUCTION TEMPERATURE - HOSHIZAKI's recommendation

- 1) Locate a Thermometer on the Evaporator Outlet Pipe at a point 2 - 4" away from the Evaporator Foam Insulation, and check the Suction Pipe temperature.
- 2) Adjust the Constant Pressure Expansion Valve so that the Thermometer can show the values indicated in "III. 4. PERFORMANCE DATA." A frost line should be in front of the Compressor Inlet Pipe. Note that this target is a center of temperature fluctuation.

[c] SUCTION PRESSURE

- 1) Attach a pressure gauge to the Refrigerant Access Valve.
- 2) Adjust the Constant Pressure Expansion Valve so that the pressure gauge shows the following value. A frost line should be in front of the Compressor Inlet Pipe.

DCM-240BAA, BAB Refrigerant 12 9 - 11 PSIG

Note: A 90° rotation of the Adjust Screw makes a 1.4 - 1.7 PSIG increase or decrease, depending on directions.

CW - to increase the low-side pressure
CCW - to decrease the low-side pressure

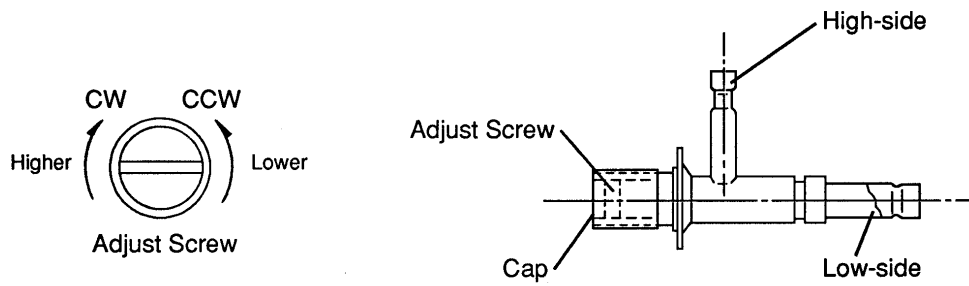

SERVICE DIAGNOSIS

1. NO ICE PRODUCTION

PROBLEM	POSSIBLE CAUSE		REMEDY
[1] The ice dispenser will not start.	a) Power Supply Cord	1. Broken or loose connection.	1. Check for continuity and replace.
	b) Power Switch (on left bottom of Front Panel)	1. OFF position.	1. Move to ON position.
	c) Fuse 1A (Control Box) 15A (Next to Power Sw.) [Except DCM-240BAE]	1. Blown out.	1. Check for short-circuit and replace.
[2] Water Valve operates, but no ice is produced.	a) Water Supply Line	1. Shut-off Valve closed.	1. Open.
		2. Water supply OFF.	2. Check and get recommended pressure.
	b) Water Valve	1. Clogged.	1. Clean.
	c) Water Control Relay	1. Bad contacts. (Terminal Nos. 4 and 6)	1. Check for continuity and replace.
		2. Coil winding opened.	2. Replace.
		3. Loose connections.	3. Tighten.
	d) Timer	1. Bad contacts.	1. Check for continuity and replace.
		2. Coil winding opened.	2. Replace.
3. Loose connections.		3. Tighten.	
4. Defective.		4. Replace.	
[3] Compressor will not start.	a) Compressor	1. Motor winding opened or grounded.	1. Replace.
	b) Timer	1. Bad contacts. (X2 Relay)	1. Check for continuity and replace.
		2. X2 Relay coil winding opened.	2. Replace.
		3. Loose connections.	3. Tighten.
	c) Motor Protector	1. Bad contacts.	1. Check for continuity and replace.
	d) Starter	1. Bad contacts.	1. Check for continuity and replace.
e) Starting or Running Capacitor	1. Defective.	1. Replace.	
[4] Gear Motor will not start.	a) Gear Motor	1. Motor winding opened.	1. Replace.
	b) Timer	1. Bad contacts. (X1 Relay)	1. Check for continuity and replace.
		2. X1 Relay coil winding opened.	2. Replace.
		3. Loose connections.	3. Tighten.
	c) Protect Relay	1. Bad contacts.	1. Check for continuity and replace.
		2. Coil winding opened.	2. Replace.
		3. Loose connections.	3. Tighten.
	d) Protector	1. Bad contact.	1. Check for continuity and replace.
e) Capacitor	1. Defective.	1. Replace.	

PROBLEM	POSSIBLE CAUSE		REMEDY
[5] Fan Motor will not start.	a) Fan Motor	1. Motor winding opened.	1. Replace.
		2. Bearing worn out.	2. Replace.
		3. Wiring to Fan Motor.	3. Check for loose connection or open, and replace.
		4. Fan blade bound	4. Check and replace.
	b) Timer	1. Bad contacts. (X2 Relay)	1. Check for continuity and replace.
		2. X2 Relay coil winding opened.	2. Replace.
3. Loose connections.		3. Tighten.	
[6] No water or poor flow.	a) Water Supply	1. Water failure or pressure too low.	1. Wait till water is supplied, or adjust the pressure range within 7 - 113 PSIG.
		2. Shut-off Valve closed or restricted.	2. Open.
	b) Water Valve	1. Clogged filter.	1. Clean.
		2. Coil winding opened.	2. Replace.
	c) Float Switch	1. Contacts fused.	1. Replace.
		2. Clogged.	2. Clean.
	d) Water Control Relay	1. Bad contacts. (Terminal Nos. 1 and 5)	1. Check for continuity and replace.
		2. Contacts fused. (Terminal Nos. 3 and 5)	1. Replace.
	e) Bin Control Switch	1. Bad contacts.	1. Check for continuity and replace.
	f) Ice Making Switch	1. OFF position.	1. Move to ON position.
2. Bad contacts.		2. Check for continuity and replace.	
g) Drain Cap	1. Removed.	1. Install.	
[7] Ice dispenser will not stop even if out of water.	a) Float Switch	1. Contacts fused.	1. Replace.
		2. Clogged.	2. Clean.
	b) Water Control Relay	1. Contacts fused. (Terminal Nos. 4 and 6)	1. Replace.

2. LOW ICE PRODUCTION

PROBLEM	POSSIBLE CAUSE		REMEDY
[1] Abnormal refrigeration circuit.	a) Condenser	1. Dirty Air Filter or Condenser.	1. Clean.
		2. Bad ventilation.	2. Remove anything blocking vents.
	b) Constant Pressure Expansion Valve [DCM-240BAA, BAB]	1. Low-side pressure or temperature exceeding the limit.	1. Check and adjust. See "ADJUSTMENT OF COMPONENTS, 1. CONSTANT PRESSURE EXPANSION VALVE."
	c) Thermostatic Expansion Valve [DCM-240BAE]	1. Low-side pressure or temperature exceeding the limit.	1. Secure bulb to low-side line or replace.
	d) Refrigerant Lines	1. Gas leaks.	1. Check for leaks with a leak detector. Reweld leak, replace drier and charge with refrigerant. The amount of refrigerant is marked on Nameplate.
		2. Overcharged.	2. Recharge.
	e) Compressor Motor Protector	1. Overload Protector stops Compressor intermittently.	1. Check Condenser and Fan Motor.
f) Inside Wall of Evaporator	1. Scale on inside wall of Freezing Cylinder.	1. Remove Auger. Use "LIME-A-WAY" solution to clean periodically. If water is found to surpass the following levels, install a conditioner. Hardness 50 ppm Silica 30 ppm	
[2] Condensing temperature too high.	a) Condenser	1. Dirty Air Filter or Condenser.	1. Clean.
		2. Bad ventilation.	2. Remove anything blocking vents.
		3. Ambient temperature too high.	3. Check ventilation and location, and change as needed.
		4. Less than 6" clearance at rear, sides and top.	4. Allow proper clearance for ventilation.
	b) Fan Motor	1. Fan revolving too slow	1. See chart 1 - [5] - a).
[3] Poor water flow.	a) Water Supply	1. Water pressure too low.	1. See chart 1 - [6] - a).

3. FAULTY DISPENSER

PROBLEM	POSSIBLE CAUSE		REMEDY
[1] No ice is dispensed.	a) Storage Bin	1. Ice block or bridge	1. Remove all ice from Storage Bin when not using ice dispenser for a long time.
	b) Agitator	1. Deformed due to ice block or bridge	1. Replace.
	c) Solenoid	1. Coil winding opened.	1. Replace.
	d) Ice Switch or Dispensing Switch	1. Bad contacts.	1. Check for continuity and replace.
	e) Ice Dispensing Relay	1. Bad contacts.	1. Check for continuity and replace.
[2] No water is dispensed.	a) Water Valve (Dispensing)	1. Clogged Filter.	1. Clean.
		2. Coil winding opened.	2. Replace.
	b) Water Switch or Dispensing Switch	1. Bad contacts.	1. Check for continuity and replace.
[3] Ice keeps being dispensed.	a) Shutter	1. Faulty adjustment.	1. With Shutter closed, lock Shutter in place by securing with two screws at the lower part of Solenoid and two screws under Solenoid.
	b) Ice Switch and Dispensing Switch	1. Contacts fused.	1. Replace.
		2. Faulty adjustment. [DCM-240BAA only]	2. Loosen two screws, and secure Switch in place.
	c) Working Bar [DCM-240BAA only]	1. Caught in the hole on Lower Front Panel.	1. Smooth the hole on the panel.
2. Switch Actuating Screw too tight.		2. Loosen screw so it can move smoothly.	

4. OTHERS

PROBLEM	POSSIBLE CAUSE		REMEDY
[1] Ice dispenser will not stop even if filled with ice.	a) Bin Control Switch	1. Contacts fused.	1. Replace.
		2. Out of position.	2. Reinstall.
	b) Water Control Relay	1. Contacts fused.	1. Replace.
[2] Reservoir overflows. (Water will not stop.)	c) Timer	1. Defective.	1. Replace.
	a) Water Supply	1. Water pressure too high.	1. If pressure is consistently too high, install a pressure reducing valve.
	b) Water Valve	1. Cannot close.	1. Clean or replace.
	c) Float Switch	1. Bad contacts. (Red and black leads)	1. Check for continuity and replace.
2. Defective.		2. Replace.	
d) Water Control Relay	1. Coil winding opened.	1. Replace.	
	2. Bad contacts. (Terminal Nos. 1 and 3)	2. Check for continuity and replace.	
[3] Much water drains from Gear Motor Drain Pipe.	a) Mechanical Seal (Normally less than 0.017 fl. oz./hour)	1. Dirt stuck on seal surface.	1. Clean or replace.
		2. Worn out.	2. Replace.
[4] Abnormal noise.	a) Fan Motor	1. Bearings worn out.	1. Replace.
		2. Fan blade deformed.	2. Replace fan blade.
		3. Fan blade caught on a foreign matter.	3. Remove the matter.
	b) Compressor	1. Bearings worn out, or cylinder valve broken.	1. Replace.
		2. Mounting pad out of position.	2. Reinstall.
	c) Refrigerant Lines	1. Rub or touch lines or other surfaces.	1. Replace.
	d) Gear Motor (Ice Making)	1. Bearing or Gear wear/damage	1. Replace.
	e) Evaporator	1. Low-side pressure too low.	1. [Except DCM-240BAE] Adjust Expansion Valve. Turn Adjust Screw CW. See "ADJUSTMENT OF COMPONENTS, 1. CONSTANT PRESSURE EXPANSION VALVE."
		2. Scale on inside wall of Freezing Cylinder.	2. See chart 2 - [1] - f).
	f) Solenoid (Shutter)	1. Worn out.	1. Replace.
		2. Foreign matter on Plunger surface.	2. Clean.
	g) Water Valve	1. Foreign matter on Plunger.	1. Clean.
	h) Extruding Head	1. Bearing worn out.	1. Replace.
i) Housing	1. Bearing worn out.	1. Replace.	

REMOVAL AND REPLACEMENT OF COMPONENTS

1. SERVICE FOR REFRIGERANT LINE

[a] REFRIGERANT RECOVERY

This ice dispenser is provided with two Refrigerant Access Valves on the low-side and high-side lines. Recover the refrigerant from these two Access Valves and store it in an approved container. Do not discharge the refrigerant into the atmosphere.

[b] EVACUATION AND RECHARGE

- 1) Attach Charging Hoses, a Service Manifold and a Vacuum Pump to the system.
- 2) Turn on the Vacuum Pump.
- 3) Allow the Vacuum Pump to pull down to a 29.9" Hg vacuum. Evacuating period depends on pump capacity.
- 4) Close the Low-side Valve on the Service Manifold.
- 5) Disconnect the Vacuum Pump, and attach a Refrigerant Service Cylinder. Remember to loosen the connection, and purge the air from the Hose. See the Nameplate for refrigerant charge. Hoshizaki recommends only virgin refrigerant or reclaimed refrigerant which meets ARI Standard No. 700-88 be used.
- 6) Open the Low-side Valve. Do not invert the Service Cylinder. A liquid charge will damage the Compressor.
- 7) Turn on the ice dispenser when charging speed gets slow. Turn off the ice dispenser when the Low-side Gauge shows approximately 0 PSIG. Do not run the ice dispenser at negative pressures. Close the Low-side Valve when the Service Cylinder gets empty.
- 8) Repeat the above steps 4) through 7), if necessary, until the required amount of refrigerant has entered the system.
- 9) Close the Refrigerant Access Valve, and disconnect the Hoses and Service Manifold.
- 10) Cap the Access Valve to prevent a possible leak.

2. BRAZING

DANGER

1. Refrigerant R12 or R22 itself is not flammable, explosive and poisonous. However, when exposed to an open flame, R12 or R22 creates Phosgene gas, hazardous in large amounts.
2. Always recover the refrigerant and store it in an approved container. Do not discharge the refrigerant into the atmosphere.
3. Do not use silver alloy or copper alloy containing Arsenic.
4. In its liquid state, the refrigerant can cause frostbite because of the low temperature.

3. REMOVAL AND REPLACEMENT OF COMPRESSOR

IMPORTANT

Always install a new Drier every time the sealed refrigeration system is opened. Do not replace the Drier until after all other repair or replacement has been made.

- 1) Turn off the power supply.
- 2) Remove the panels.
- 3) Remove the Terminal Cover on the Compressor, and disconnect the Compressor Wiring.
- 4) Recover the refrigerant and store it in an approved container.
- 5) Unsolder and disconnect the Discharge and Suction Pipes from the Compressor.

WARNING

When repairing a refrigerant system, be careful not to let the burner flame contact the lead wires or insulation.

- 6) Remove the Hold-down Bolts, Washers and Rubber Grommets.
- 7) Slide and remove the Compressor. Unpack the new Compressor package. Install the new Compressor.
- 8) Attach the Rubber Grommets of the prior Compressor.
- 9) Sandpaper the Suction, Discharge and Process Pipes.
- 10) Place the Compressor in position, and secure it using the Bolts and Washers.
- 11) Remove plugs from the Suction, Discharge and Process Pipes.
- 12) Braze the Process, Suction and Discharge Pipes (Do not change this order), with nitrogen gas flowing at the pressure 3 - 4 PSIG.
- 13) Replace the Drier.
- 14) Check for leaks using nitrogen gas (140 PSIG) and soap bubbles.

- 15) Connect the Compressor Wiring to the Compressor, and replace the Terminal Cover.
- 16) Evacuate the system, and charge it with refrigerant. See the Nameplate for the required refrigerant charge.
- 17) Replace the panels in their correct position.
- 18) Turn on the power supply.

[DCM-240BAA, DCM-240BAB]

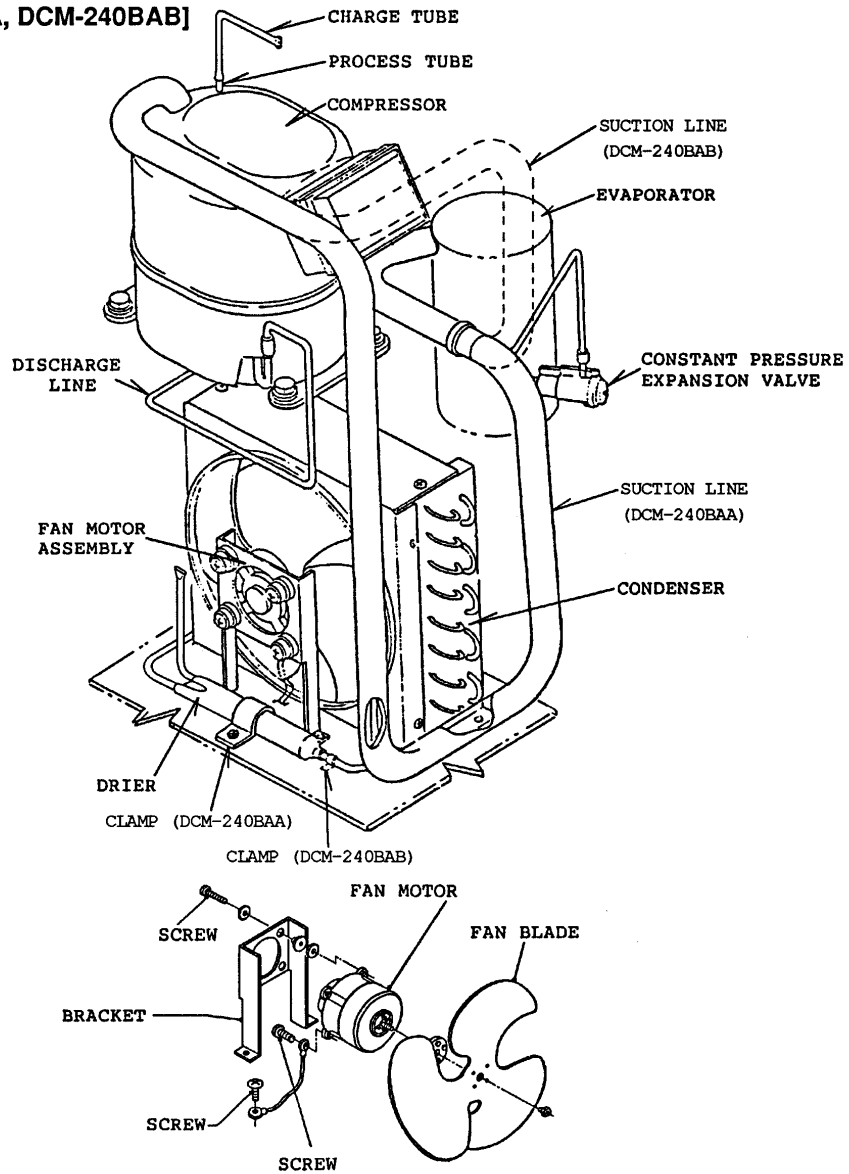

DCM9404

[DCM-240BAE]

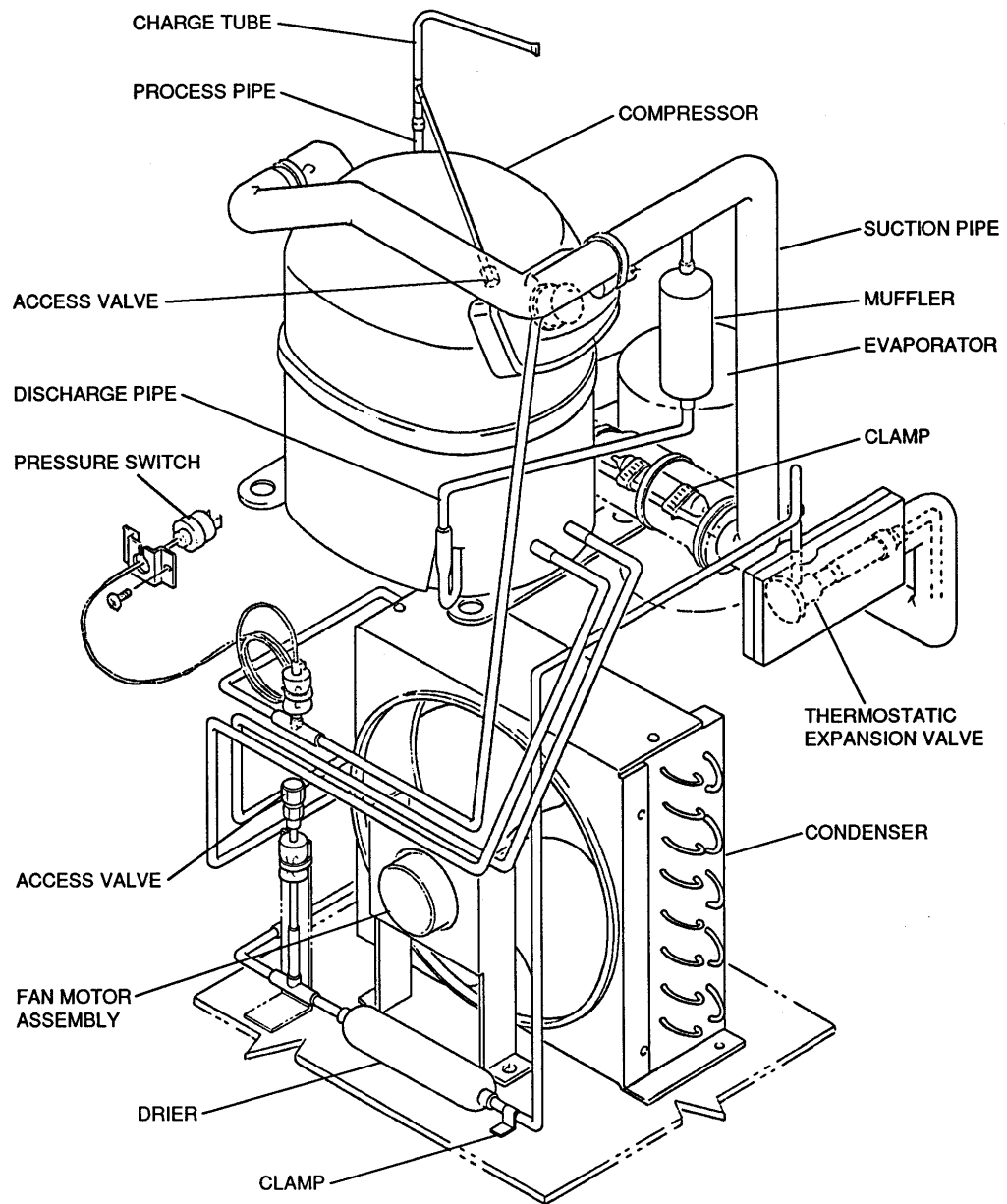

4. REMOVAL AND REPLACEMENT OF DRIER

- 1) Turn off the power supply.
- 2) Remove the panels.
- 3) Recover the refrigerant and store it in an approved container.
- 4) Remove the Clamp securing the Drier, and pull the Drier toward you for easy service.
- 5) Remove the Drier using brazing equipment.
- 6) Install the new Drier in the direction of the refrigerant flow. Use nitrogen gas at the pressure of 3 - 4 PSIG when brazing the tubings.
- 7) Check for leaks using nitrogen gas (140 PSIG) and soap bubbles.
- 8) Secure the Drier with the Clamp.
- 9) Evacuate the system, and charge it with refrigerant. See the Nameplate for the required refrigerant charge.
- 10) Replace the panels in their correct position.
- 11) Turn on the power supply.

5. REMOVAL AND REPLACEMENT OF CONSTANT PRESSURE EXPANSION VALVE (DCM-240BAA, BAB) AND THERMOSTATIC EXPANSION VALVE (DCM-240BAE)

IMPORTANT

Sometimes moisture in the refrigeration circuit exceeds the Drier capacity and freezes up at the Expansion Valve. Always install a new Drier every time the sealed refrigeration system is opened. Do not replace the Drier until after all other repair or replacement has been made.

- 1) Turn off the power supply.
- 2) Remove the panels.
- 3) Recover the refrigerant and store it in an approved container.
- 4) Remove the Insulation covering the Expansion Valve Bulb [DCM-240BAE only].
- 5) Remove the two Clamps securing the Expansion Valve Bulb [DCM-240BAE only].
- 6) Remove the Expansion Valve Cover.
- 7) Disconnect the Expansion Valve using brazing equipment.
- 8) Braze the new Expansion Valve, with nitrogen gas flowing at the pressure of 3 - 4 PSIG.

WARNING

Always protect the valve body by using a damp cloth to prevent the valve from overheating. Do not braze with the valve body exceeding 250°F.

- 9) Install the new Drier.
- 10) Check for leaks using nitrogen gas (140 PSIG) and soap bubbles.
- 11) Evacuate the system, and charge it with refrigerant. See the Nameplate for the required refrigerant charge.
- 12) Place the Expansion Valve in position.
- 13) Attach the Expansion Valve Bulb to the low-side line, and secure them with the Clamps at the maximum torque of 6.5 kgfcm [DCM-240BAE only].

- 14) Cover the Expansion Valve Bulb tightly with the Insulation [DCM-240BAE only].
- 15) Place the new set of Expansion Valve Covers in position.
- 16) Replace the panels in their correct position.
- 17) Turn on the power supply.

6. REMOVAL AND REPLACEMENT OF PRESSURE SWITCH - DCM-240BAE ONLY

IMPORTANT

Always install a new Drier every time the sealed refrigeration system is opened. Do not replace the Drier until after all other repair or replacement has been made.

- 1) Turn off the power supply.
- 2) Remove the panels.
- 3) Recover the refrigerant and store it in an approved container.
- 4) Remove the Control Box Cover, and disconnect the terminals.
- 5) Remove the Pressure Switch using brazing equipment.
- 6) Braze the new Pressure Switch with nitrogen gas flowing at the pressure of 3 - 4 PSIG.
- 7) Install the new Drier.
- 8) Check for leaks using nitrogen gas (140 PSIG) and soap bubbles.
- 9) Evacuate the system, and charge it with refrigerant. See the Nameplate for the required refrigerant charge.
- 10) Replace the terminals and the Control Box Cover in their correct position.
- 11) Replace the panels in their correct position.
- 12) Turn on the power supply.

7. REMOVAL AND REPLACEMENT OF WATER VALVE

- 1) Turn off the power supply.
- 2) Close the Water Supply Line Shut-off Valve.
- 3) Remove the Drain Cap and drain out.
- 4) Remove the panels.
- 5) Remove the valve outlet tubing by releasing the Clamp.
- 6) Remove the Fitting Nut and the Water Valve.
- 7) Install the new Water Valve.
- 8) Assemble the removed parts in the reverse order of which they were removed.
- 9) Open the Water Supply Line Shut-off Valve.
- 10) Turn on the power supply.
- 11) Check for water leaks.
- 12) Replace the panels in their correct position.

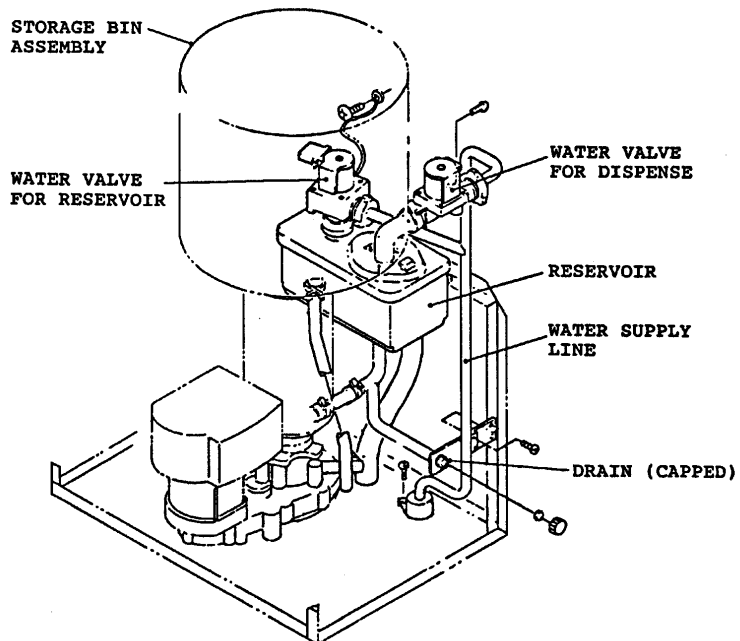
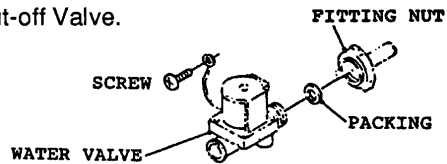

8. REMOVAL AND REPLACEMENT OF FLOAT SWITCH

WARNING

1. Fragile, handle very carefully.
2. If the Float Switch works poorly because of scale or other foreign matter, install a filter or softener in the water supply line.

- 1) Turn off the power supply.
- 2) Close the Water Supply Line Shut-off Valve.
- 3) Remove the Drain Cap and drain out.
- 4) Remove the panels.
- 5) Cut the Float Switch leads at the wire connectors.
- 6) Turn and unfasten the flanged top, and remove the Float Switch.
- 7) Install the new Float Switch.
- 8) Assemble the removed parts in the reverse order of which they were removed.
- 9) Open the Water Supply Line Shut-off Valve.
- 10) Turn on the power supply, and check that the Float Switch works normally.

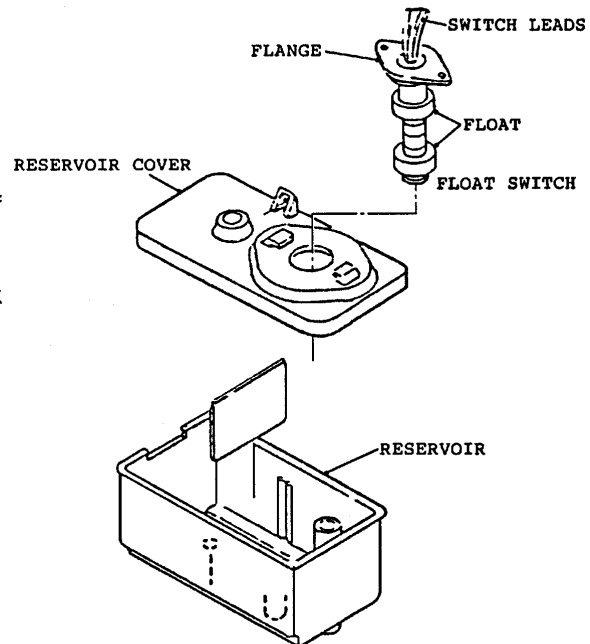

9. REMOVAL AND REPLACEMENT OF BIN CONTROL SWITCH ASSEMBLY

- 1) Turn off the power supply.
- 2) Remove the Top Panel.
- 3) Remove the Storage Bin Cover.
- 4) Remove the Bin Control Switch.
- 5) Remove the Snap Pin and E-ring, and disassemble the Balance Plate (A), Balance Plate (B) and Shaft.
- 6) Rotate the Inside Cover counterclockwise and remove.
- 7) Assemble the removed parts in the reverse order of which they were removed.
- 8) Turn on the power supply, and check that the Bin Control Switch works normally.

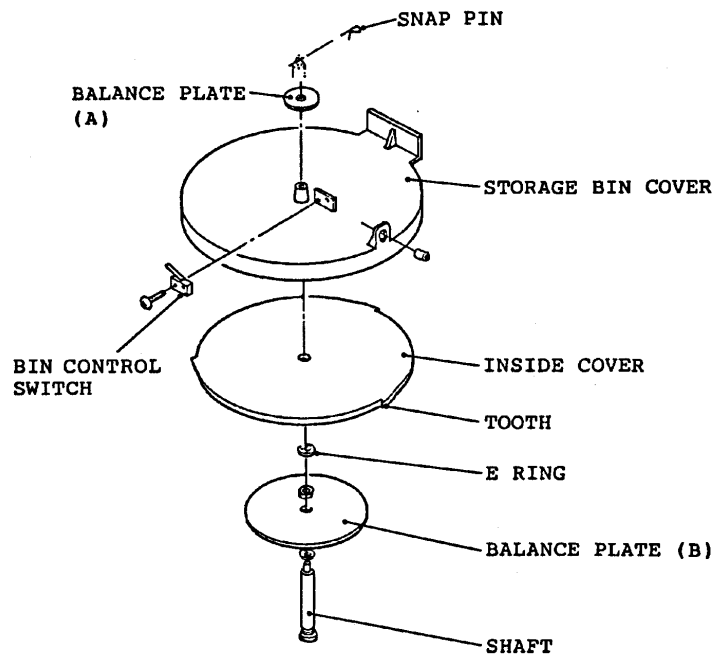

10. REMOVAL AND REPLACEMENT OF STORAGE BIN ASSEMBLY

- 1) Move the Ice Making Switch to the "OFF" position.
- 2) Press the Push Lever or Push Button to dispense ice, and remove all ice from the Storage Bin.
- 3) Turn off the power supply.
- 4) Remove the Drain Cap, and drain out.
- 5) Remove the panels.
- 6) Remove the Storage Bin Cover.
- 7) Remove the Agitator, Drip Ring, Drip Plate and Shutter Assembly.
- 8) Remove the three Socket Head Cap Screws, and lift off the Storage Bin Assembly.
- 9) Install the new Storage Bin Assembly.
- 10) Assemble the removed parts in the reverse order of which they were removed.
- 11) Turn on the power supply.
- 12) Move the Shutter to check for proper operation.
- 13) Move the Ice Making Switch to the "ON" position.

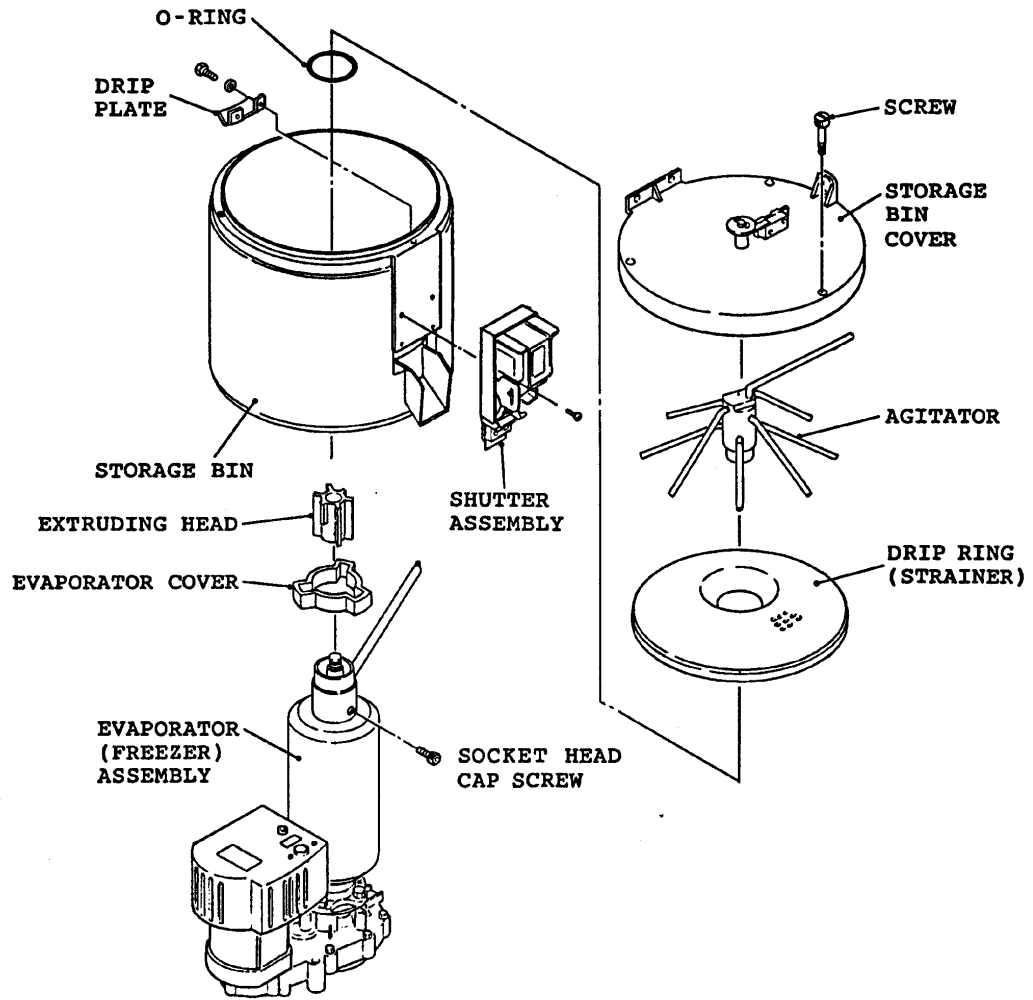

11. REMOVAL AND REPLACEMENT OF AGITATOR AND DRIP RING

- 1) Move the Ice Making Switch to the "OFF" position.
- 2) Press the Push Lever or Push Button to dispense ice, and remove all ice from the Storage Bin.
- 3) Turn off the power supply.
- 4) Remove the Top Panel.
- 5) Remove the Storage Bin Cover.
- 6) Rotate the Agitator counterclockwise, and lift off.
- 7) Rotate the Drip Ring about 30 degrees clockwise, and lift off.
- 8) Install the new Drip Ring and Agitator.
- 9) Assemble the removed parts in the reverse order of which they were removed.
- 10) Turn on the power supply.
- 11) Move the Ice Making Switch to the "ON" position.

12. REMOVAL AND REPLACEMENT OF EVAPORATOR ASSEMBLY

- 1) Move the Ice Making Switch to the "OFF" position.
- 2) Press the Push Lever or Push Button to dispense ice, and remove all ice from the Storage Bin.
- 3) Turn off the power supply.
- 4) Remove the Drain Cap, and drain out.
- 5) Remove the panels.
- 6) Remove the Storage Bin Assembly. (See "10. STORAGE BIN ASSEMBLY.")

EXTRUDING HEAD

- 7) Lift off the Extruding Head.
- 8) Replace the Bearing inside the Extruding Head, if it is worn or scratched.

Note: Replacing the Bearing needs a fitting tool. If it is not available, replace the whole Extruding Head.

AUGER

- 9) Lift up and turn the Auger until it comes off. If the area in contact with the Bearing is worn out or the Blade scratched, replace the Auger.

EVAPORATOR

Note: Skip the following steps 10) through 17) when the Evaporator does not need replacement.

- 10) Recover the refrigerant and store it in an approved container.

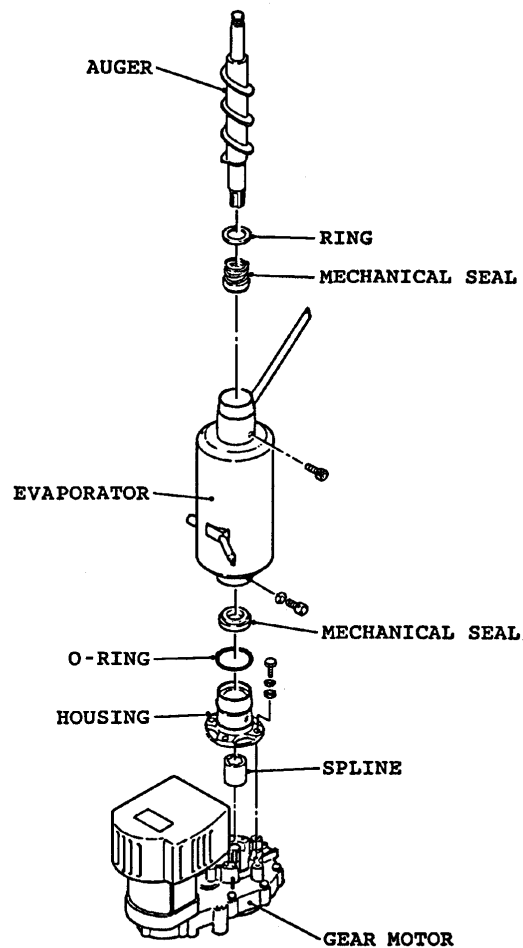

IMPORTANT

Always install a new Drier every time the sealed refrigeration system is opened. Do not replace the Drier until after all other repair or replacement has been made.

- 11) Remove the Expansion Valve Cover.
- 12) Remove the Insulation and the two Clamps on the Expansion Valve Bulb [DCM-240BAE only].
- 13) Disconnect the brazing-connections of the Expansion Valve and the Copper Tube - Low Side from the Evaporator, using brazing equipment.
- 14) Braze the new Evaporator with nitrogen gas flowing at the pressure of 3 - 4 PSIG.
- 15) Replace the Drier.
- 16) Check for leaks using nitrogen gas (140 PSIG) and soap bubbles.
- 17) Evacuate the system, and charge it with refrigerant. See the Nameplate for the required refrigerant charge.
- 18) Remove the four Socket Head Cap Screws at the bottom of the Evaporator.
- 19) Disconnect the Hose from the Evaporator.
- 20) Lift off the Evaporator.

HOUSING AND MECHANICAL SEAL

- 21) Remove the four Hexagon Bolts securing the Housing to the Gear Motor.
- 22) Remove the Mechanical Seal fixed on the Housing.

Note: The Mechanical Seal consists of two parts. One moves along with the Auger, and the other is fixed on the Housing. If the contact surfaces of these two parts is worn or scratched, the Mechanical Seal may cause water leaks and should be replaced.

- 23) Replace the Bearing inside the Housing using a fitting tool, if it is worn or scratched.

Note: Replacing the Bearing needs a fitting tool. If it is not available, replace the whole Housing. Be sure to install the O-ring.

GEAR MOTOR

- 24) Cut the Gear Motor leads at the wire connector.
- 25) Remove the three Hexagon Bolts securing the Gear Motor on the Chassis.
- 26) Remove the Gear Motor.
- 27) Install the new Gear Motor.
- 28) Assemble the removed parts in the reverse order of which they were removed.

WARNING

Be careful not to scratch the surface of the O-ring, or it may cause water leaks. Handle the Mechanical Seal with care not to scratch nor to contaminate its contact surface.

- 29) Check for water leaks.

WARNING

After assembling the Extruding Head, be sure to check that the Auger does not contact with the inner surface of the Evaporator and there is not any abnormal noise from the Bearing.

- 30) Turn on the power supply.
- 31) Move the Ice Making Switch to the "ON" position.

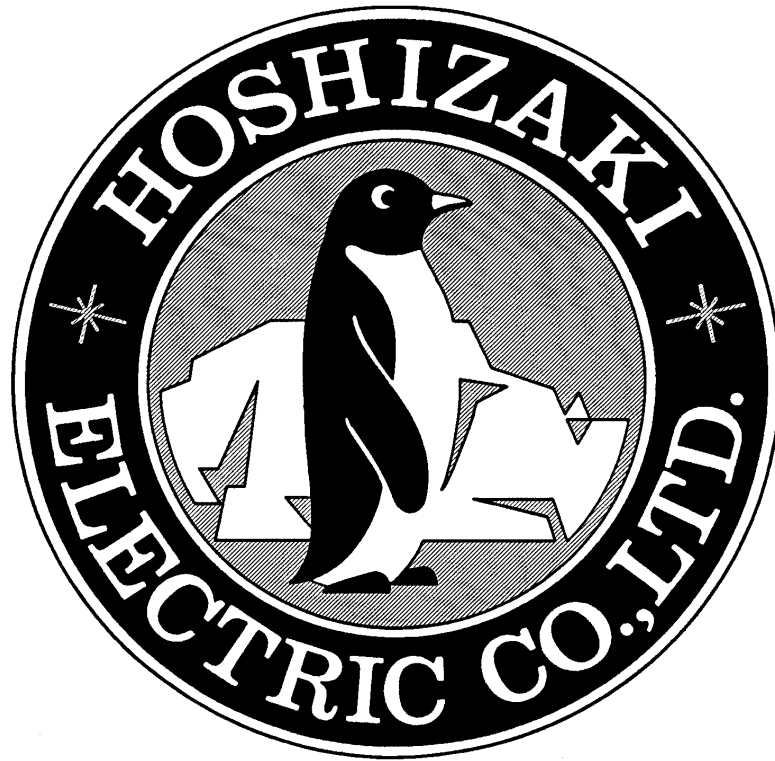

**HOSHIZAKI
CUBELET ICE DISPENSER**

**V.
MAINTENANCE AND
CLEANING INSTRUCTIONS**

CONTENTS

	PAGE
1. PREPARING THE ICEMAKER FOR LONG STORAGE	V-1
2. CLEANING INSTRUCTIONS	V-3
[a] CLEANING PROCEDURE	V-3
[b] SANITIZING PROCEDURE	V-5
[c] WATER VALVE	V-7
3. MAINTENANCE	V-8

1. PREPARING THE ICE DISPENSER FOR LONG STORAGE

IMPORTANT

When shutting off the ice dispenser for an extended time, drain out all water from the water line and remove the ice from the Storage Bin. The Storage Bin should be cleaned and dried. Drain the ice dispenser to prevent damage to the water supply line at sub-freezing temperatures, using air or carbon dioxide. Shut off the ice dispenser until the proper ambient temperature is resumed.

- 1) Close the Water Supply Line Shut-off Valve, and open the Drain Valve.
- 2) Move the Ice Making Switch, located on the left of the Middle Front Panel, to the "OFF" position.
- 3) Move the Ice Switch, located on the right of the Middle Front Panel, to the "ON" position. Move the Water Switch to the "OFF" position.
- 4) Press the Push Lever or Push Button for ice dispense, and remove all ice from the Storage Bin.
- 5) Remove the Drain Cap, and drain the Reservoir and Freezer (Water System). See Fig. 1.
- 6) Replace the Drain Cap in its correct position.
- 7) Move the Ice Switch to the "OFF" position.
- 8) Move the Power Switch, located on the left bottom of the Middle Front Panel, to the "OFF" position.
- 9) Unplug the ice dispenser.

[DCM-240BAA]

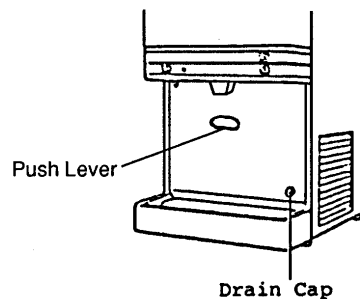

[DCM-240BAB, DCM-240BAE]

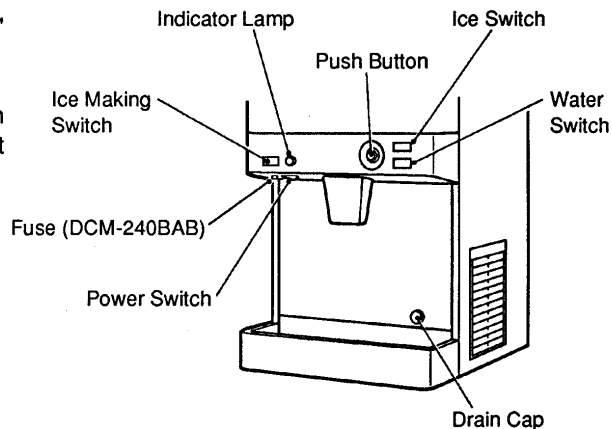

Fig. 1

IMPORTANT

Before operating the dispenser next time, check that the Drain Valve is closed, and open the Water Supply Line Shut-off Valve.

Note: When shutting off the ice dispenser at sub-freezing temperatures, run the ice dispenser, with the Water Supply Line Shut-off Valve closed, and blow out the water inlet line, by using air pressure.

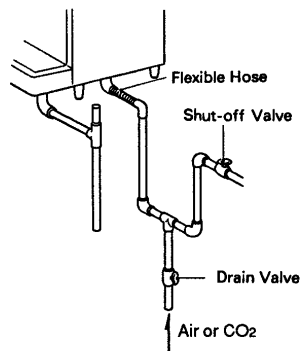

Fig. 2

2. CLEANING INSTRUCTIONS

WARNING

1. HOSHIZAKI recommends cleaning this unit at least twice a year. More frequent cleaning, however, may be required in some existing water conditions.
2. To prevent injury to individuals and damage to the ice dispenser, do not use ammonia type cleaners.
3. Always wear liquid-proof gloves for safe handling of the cleaning and sanitizing solution. This will prevent irritation in case the solution contacts with skin.

[a] CLEANING PROCEDURE

- 1) Close the Water Supply Line Shut-off Valve.
- 2) Dilute approximately 6 fl. oz. of a recommended cleaner ("LIME-A-WAY" manufactured by Economics Laboratory, Inc.) with 1 gal. of water.
- 3) Move the Ice Making Switch, located on the left of the Middle Front Panel, to the "OFF" position.
- 4) Move the Ice Switch, located on the right of the Middle Front Panel, to the "ON" position, and the Water Switch to the "OFF" position.
- 5) Press the Push Lever or Push Button to dispense ice, and remove all ice from the Storage Bin.
- 6) Remove the Drain Cap, and drain the Reservoir and Freezer.
- 7) Replace the Drain Cap in its correct position.
- 8) [DCM-240BAA]
Remove the Sound Damper inside the Dispenser Nozzle. See Fig. 3.

[DCM-240BAB, DCM-240BAE]
Remove the Spout (A) and (B) by removing the Thumbscrew, sliding the Spouts backward and then pulling them down. See Fig. 4. Pull out the Spout (A) from the Spout (B).
- 9) Remove the Top Panel and Storage Bin Cover. See Fig. 5.

[DCM-240BAA]

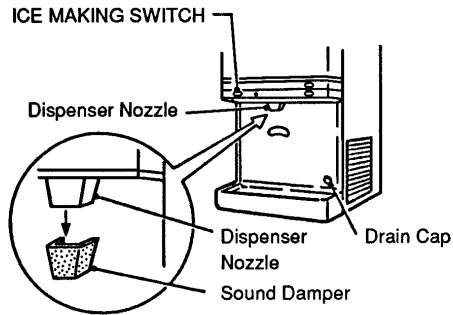

Fig. 3

[DCM-240BAB, DCM-240BAE]

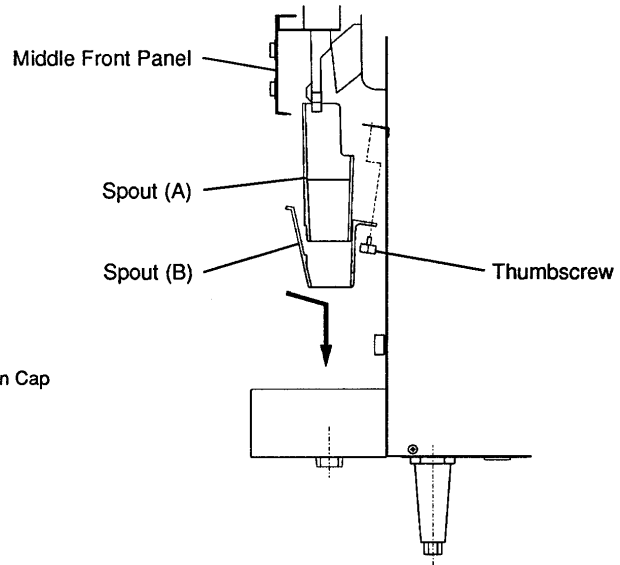

Fig. 4

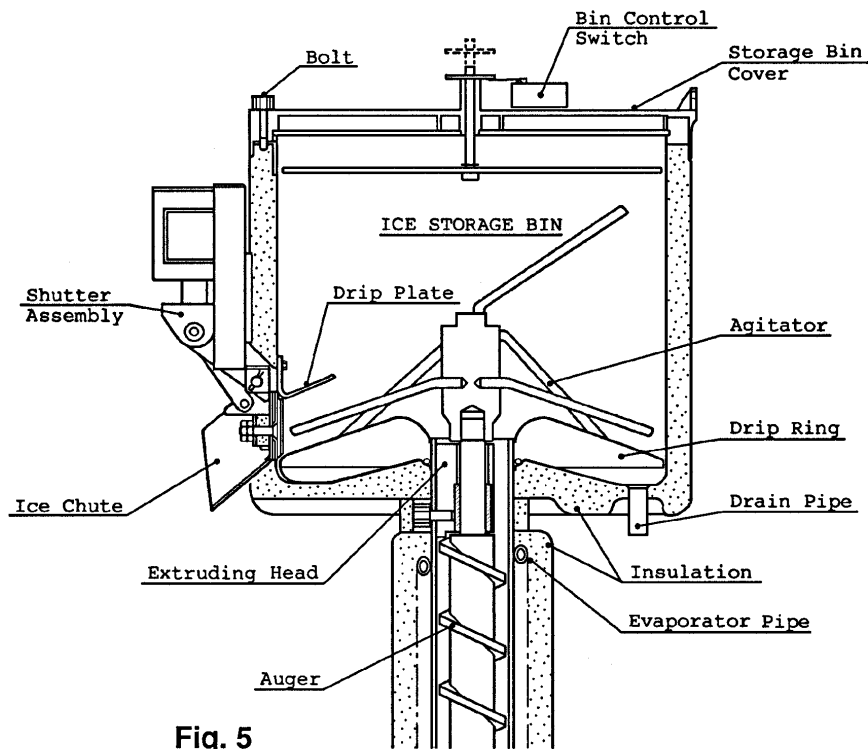

Fig. 5

- 10) Remove the Agitator and Drip Ring. See Fig. 5.
- 11) Pour the cleaning solution carefully into the Reservoir through the opening in the center of the Storage Bin up to an overflow level.
(Overflowed solution can be seen in the Drain Pan.)
- 12) While waiting for 10 minutes to start icemaking process, wipe the Bin Liner and the Drip Plate using a clean cloth containing the cleaning solution.
- 13) Move the Ice Making Switch to the "ON" position, place the Storage Bin Cover in position, and start automatic icemaking process. Run the ice dispenser until it stops automatically.
- 14) Move the Ice Making Switch to the "OFF" position.
- 15) Remove the Drain Cap and drain out.
- 16) Pour clean warm water carefully onto the Bin Liner and into the Reservoir through the opening in the center of the Storage Bin to melt the ice and rinse out the cleaning solution.
- 17) Replace the Drain Cap in its correct position.
- 18) Wipe the Storage Bin Cover, the Agitator, the Drip Ring and the Sound Damper or Spout (A) and (B) using a clean cloth containing the cleaning solution.
- 19) Rinse the parts wiped above using water.

CAUTION

Do not use ice produced with cleaning and sanitizing solutions. Be sure none remains in the Storage Bin.

[b] SANITIZING PROCEDURE - Following Cleaning Procedure

- 1) Dilute approximately 1.5 fl. oz. of a 5.25% Sodium Hypochlorite solution with 3 gal. of water.
- 2) Pour the sanitizing solution carefully into the Reservoir through the opening in the center of the Storage Bin up to an overflow level.
- 3) Wait for 10 minutes to start icemaking process. Move the Ice Making Switch to the "ON" position, and start automatic icemaking process. Run the ice dispenser until it stops automatically.
- 4) Move the Ice Making Switch to the "OFF" position.

- 5) Remove the Drain Cap and drain out.
- 6) Wipe the Bin Liner and the Drip Plate using a clean cloth containing the sanitizing solution.
- 7) Pour clean warm water carefully onto the Bin Liner and into the Reservoir through the opening in the center of the Storage Bin to melt the ice and rinse out the sanitizing solution. Be careful not to wet the Bin Control Switch on the Storage Bin Cover.
- 8) Immerse the parts rinsed in [a] step 19) into the sanitizing solution.
- 9) Rinse the parts sanitized above using water.
- 10) Replace the parts rinsed above in their correct position.
- 11) Replace the Drain Cap in its correct position, and open the Water Supply Line Shut-off Valve.
- 12) Move the Ice Making Switch to the "ON" position, and start the icemaking process. Run the ice dispenser for about 30 minutes.
- 13) Move the Ice Making Switch to the "OFF" position.
- 14) Press the Push Lever or Push Button to dispense ice, and remove all ice from the Storage Bin.
- 15) Remove the Drain Cap and drain out.
- 16) Replace the Drain Cap in its correct position.
- 17) Replace the Top Panel in its correct position.
- 18) Move the Ice Making Switch to the "ON" position, and start automatic and continuous icemaking process.

[c] WATER VALVE

IMPORTANT

If the Filter in the Water Valve becomes clogged with sediment or dirt, the water supply will be stopped and ice cannot be made. Disassemble the Water Valve and clean out the Filter once every two months.

- 1) Turn off the power supply.
- 2) Close the Water Supply Line Shut-off Valve, and open the Drain Valve.
- 3) Remove the panels.
- 4) Remove the Fitting Nut from the Water Valve. Do not lose the Packing.
- 5) Remove the Filter from the Water Valve, remove sediment or dirt, and rinse it with water.
- 6) Replace the Filter on the Water Valve.
- 7) Replace the Packing and secure it carefully with the Fitting Nut to prevent leakage.
- 8) Close the Water Supply Line Drain Valve, and open the Shut-off Valve.
- 9) Turn on the power supply.
- 10) Check for water leaks.
- 11) Replace the panels in their correct position.

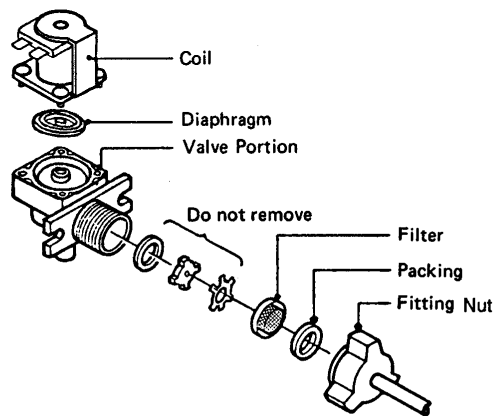

Fig. 6

3. MAINTENANCE

IMPORTANT

1. This ice dispenser must be maintained individually, referring to the instruction manual and labels provided with the ice dispenser.
2. To have the optimum performance of this ice dispenser, the following consumable parts need periodical inspection, maintenance and replacement:

Extruding Head
Housing
Gear Motor
Auger
Mechanical Seal

These parts should be inspected at least once a year or every 10,000 hours of operation. Their service life, however, depends on water quality and environment. More frequent inspection and maintenance are recommended.

Consult with your local distributor about inspection and maintenance service. To obtain the name and phone number of your local distributor, call Hoshizaki Care at 1-800-233-1940.

1) Stainless Steel Exterior

To prevent corrosion, wipe the exterior occasionally with a clean and soft cloth. Use a damp cloth containing a neutral cleaner to wipe off oil or dirt build up.

2) Air Filter - See Fig. 7

A plastic mesh air filter removes dirt or dust from the air, and keeps the Condenser from getting clogged. As the filter gets clogged, the ice dispenser's performance will be reduced. Check the filter at least twice a month. When clogged, use warm water and a neutral cleaner to wash the filter.

3) Condenser

Check the Condenser once a year, and clean if required by using a brush or vacuum cleaner. More frequent cleaning may be required depending on the location of the ice dispenser.

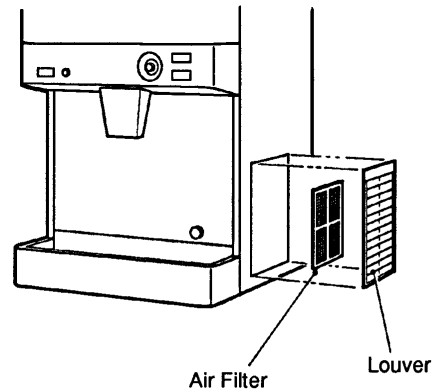

Fig. 7



HOSHIZAKI
HOSHIZAKI ELECTRIC CO., LTD.

TOYOAKE, AICHI, JAPAN
PHONE: 0562-97-2111
TELEX-NO: 04486-514 HOSHI J

Free Manuals Download Website

<http://myh66.com>

<http://usermanuals.us>

<http://www.somanuals.com>

<http://www.4manuals.cc>

<http://www.manual-lib.com>

<http://www.404manual.com>

<http://www.luxmanual.com>

<http://aubethermostatmanual.com>

Golf course search by state

<http://golfingnear.com>

Email search by domain

<http://emailbydomain.com>

Auto manuals search

<http://auto.somanuals.com>

TV manuals search

<http://tv.somanuals.com>