

# Hoshizaki America, Inc.

## Modular Crescent Cuber

### Models

KML-45 IMAH

KML-45 IMWH



“A Superior Degree  
of Reliability”

[www.hoshizaki.com](http://www.hoshizaki.com)

## PARTS LIST



Number: 71262  
Issued: 10-12-2006  
Revised: 9-25-2009

## CONTENTS

Auxiliary Codes.....	3
Note About Ordering Parts .....	3
Material Abbreviations .....	4
A. Ice Cuber Assembly .....	5
KML-451MAH.....	5
KML-451MWH.....	8
B. Refrigeration Circuit .....	10
KML-451MAH.....	10
KML-451MWH.....	14
C. Water Circuit .....	18
D. Control Box Assembly.....	22
E. Label Location.....	24
KML-451MAH.....	24
KML-451MWH.....	26
F. Top Panel Assembly .....	28
G. Front Panel Assembly.....	29
H. Accessories & Packaging .....	30

## Auxiliary Codes

<b>KML-451MAH</b>	R-0	June 2006
	S-1	January 2007
	S-2	December 2007
	T-0	January 2008
	T-1	November 2008
	T-2	December 2008
	U-0	January 2009
	U-1	August 2009

<b>KML-451MWH</b>	R-0	June 2006
	S-1	April 2007
	S-2	December 2007
	T-0	January 2008
	U-0	January 2009
	U-1	January 2009

## Auxiliary Code Breakdown

The auxiliary code is the first two characters in the serial number. The first character indicates the year. Years progress or regress in alphabetical order. The series runs from "A" through "V" and the letters "I" and "O" are skipped. The second character indicates significant part changes within a year. Base is "0" and this number advances for each change. In cases where there is a letter in parentheses, this designates the month. This is the last character in the serial number. The series runs from "(A)" through "(M)" and the letter "(I)" is skipped. This designation is only included when identifying a parts change within an auxiliary code.

## Note About Ordering Parts

Most assemblies cannot be ordered as complete units; parts in the assemblies generally must be ordered separately.

## Material Abbreviations

### ALUMINUM

AL = Aluminum

### COPPER

CU = Copper

### PLASTIC

ABS = Acrylonitrile -butadiene -styrene  
AC = Polyacetal  
EVA = Ethylene vinyl acetate  
PA = Polyamide = Nylon  
PC = Polycarbonate  
PE = Polyethylene  
PES = Polyester  
PETP = Polyethylene terephthalate = Tetlon  
PP = Polypropylene  
PS = Polystyrene  
PTFE = Polytetrafluoroethylene = Teflon  
PUR = Polyurethane  
PVC = Polyvinyl chloride

### RUBBER

VN = Vinyl Nitrile  
EPDM = EP rubber  
NBR = Nitrile butadiene rubber  
NR = Natural rubber  
NP = Neoprene  
SI.R = Silicone rubber  
SY.R = Synthetic rubber  
EPH = Epichlorohydrin

### STEEL

GS = Galvanized steel  
SS = Stainless steel  
PS = Plated steel  
PAS = Primed steel

# A. Ice Cuber Assembly

## KML-451MAH

R-0 to U-1

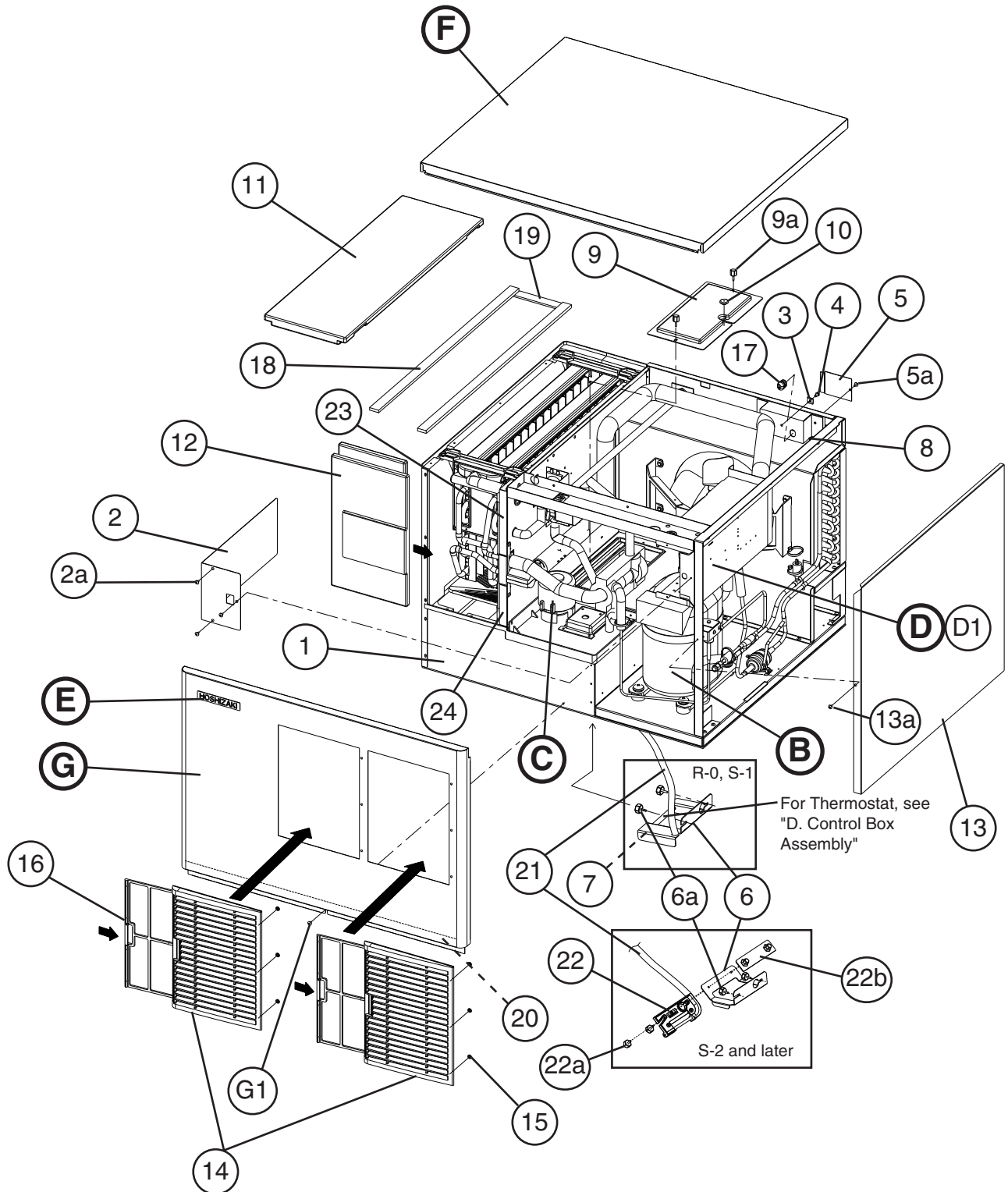

Title: <b>A. Ice Cuber Assembly</b> Model: <b>KML-451MAH</b>												
Index No.	Description	Material Or Model Number	Part Number	Required Number								
				R-0 S-1	S-2 T-0 T-2 U-0	T-1	U-1					
B	Refrigeration Circuit	-	1A1143A01	1	1	-						
			1A1678A01			1	1					
C	Water Circuit	-	1A1186A01	1	1	-						
			1A1186A02			1	-					
			1A1186A04					1				
D	Control Box Assembly	-	2A2541A01	1	1	-						
			2A4901A01			1	-					
			2A4901A03					1				
D1	T2 Screw	4x8	7P31-0408	3	3	3	3					
E	Label Location	-	3A3915A01	1	1	-						
			3A5154A01			1	-					
			3A5480A01					1				
F	Top Panel Assembly	-	3A1862A01	1	1	1	1					
G	Front Panel Assembly	-	3A1859A01	1	1	1	1					
G1	Truss Head Screw	4x8, SS	7C32-0408	1	1	1	1					
1	Evaporator Case	HS-1014	2A2113G02	1	1	1	1					
2	Control Box Cover	GS	3A2371-01	1	1	1	1					
2a	T2 Screw	4x8	7P31-0408	3	3	3	3					
3	Square Washer	Brass	433537-02	1	1	1	1					
4	Screw-Grounding	Brass	433304-02	1	1	1	1					
5	Junction Box Cover	GS	433410-01	1	1	1	1					
5a	T2 Screw	4x8	7P31-0408	1	1	1	1					
6	Thermostat Extension Bracket	SS	4A3436-01	1	-							
			4A4358-01		1	1	1					
6a	Thumbscrew	SS, ABS	415949G10	2	2	2	2					
7	Spacer	PE	443545-01	2	-							
8	Wire Saddle	VWS4238-C	4A0338-02	2	2	2	2					
9	Bin Control Cover	GS	3A0664G01	1	1	1	1					
9a	Thumbscrew	SS, ABS	415949G08	2	2	2	2					
10	Capillary Ring	EP Rubber	425307-01	1	1	1	1					
11	Top Insulation	PP	215730G01	1	1	1	1					
12	Front Insulation	-	2A0664G01	1	1	-						
			2A4540A01			1	1					
13	Side Panel (R)	SS	2A2111G01	1	1	1	1					
13a	T2 Screw	4x8, SS	7P32-0408	1	1	1	1					
14	Louver	ABS	1A0548-01	2	2	2	2					
15	Push Retainer	-	4A2414-01	6	6	6	6					
16	Air Filter	ABS	2A2063G01	2	2	2	2					
17	Bushing	SR-30-1	420472-03	1	1	1	1					
18	Gasket	L=655	4A0808L02	2	2	2	2					
19	Gasket	L=190	4A0808L02	1	1	1	1					
20	Gasket	L=762	4A0808L02	1	1	1	1					
21	Silicone Hose	L=310	7730I3812	1	1	1	1					

Title: **A. Ice Cuber Assembly** Model: **KML-451MAH**

Index No.	Description	Material Or Model Number	Part Number	Required Number									
				R-0 S-1	S-2 T-0 T-2 U-0	T-1	U-1						
22	Bulb Holder	-	3A3903-01		1	1	1						
22a	Thumbscrew	-	415949G11		2	2	2						
22b	NSF Plate	-	4A4401G01		1	1	1						
23	Gasket	L=170	4A0808L02			1	1						
24	Gasket	L=112	4A0808L02			1	1						

**A. Ice Cuber Assembly**  
**KML-451MWH**  
 R-0 to U-1

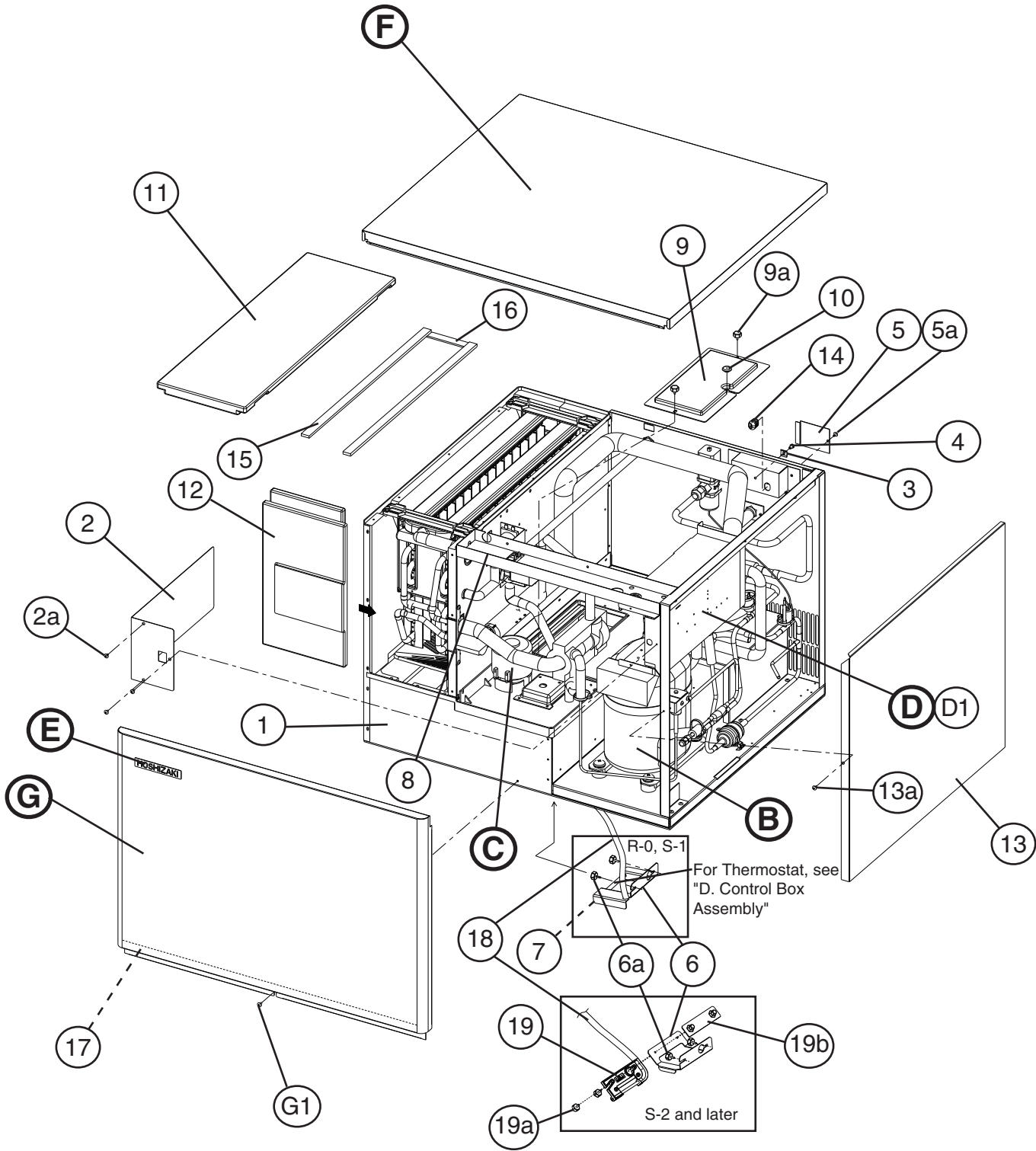



Title: **A. Ice Cuber Assembly** Model: **KML-451MWH**

Index No.	Description	Material or Model Number	Part Number	Required Number									
				R-0 S-1	S-2 to U-0	U-1 (A-G)	U-1 (H-M)						
B	Refrigeration Circuit	-	1A1144A01	1	1	-							
			1A1679A01			1	1						
C	Water Circuit	-	1A1186A01	1	1	-							
			1A1186A02			1	-						
			1A1186A04				1						
D	Control Box Assembly	-	2A2541A02	1	1	-							
			2A4901A02			1	-						
			2A4901A04				1						
D1	T2 Screw	4x8	7P31-0408	3	3	3	3						
E	Label Location	-	3A3916A01	1	1	-							
			3A5155A01			1	-						
			3A5483A01				1						
F	Top Panel Assembly	-	3A1862A01	1	1	1	1						
G	Front Panel Assembly	-	3A1859A02	1	1	1	1						
G1	Truss Head Screw	4x8, SS	7C32-0408	1	1	1	1						
1	Evaporator Case	-	2A2113G02	1	1	1	1						
2	Control Box Cover	GS	3A2371-01	1	1	1	1						
2a	T2 Screw	4x8	7P31-0408	3	3	3	3						
3	Square Washer	BRASS	433537-02	1	1	1	1						
4	Screw-Grounding	BRASS	433304-02	1	1	1	1						
5	Junction Box Cover	GS	433410-01	1	1	1	1						
5a	T2 Screw	4x8	7P31-0408	1	1	1	1						
6	Thermostat Extension Bracket	SS	4A3436-01	1	-								
			4A4358-01		1	1	1						
6a	Thumbscrew	SS, ABS	415949G10	2	2	2	2						
7	Spacer	PE	443545-01	2	-								
8	Wire Saddle	VWS4238-C	4A0338-02	2	2	2	2						
9	Bin Control Cover	GS	3A0664G01	1	1	1	1						
9a	Thumbscrew	SS, ABS	415949G08	2	2	2	2						
10	Capillary Ring	EP RUBBER	425307-01	1	1	1	1						
11	Top Insulation	PP	215730G01	1	1	1	1						
12	Front Insulation	PP	2A0664G01	1	1	1	1						
13	Side Panel (R)	SS	2A2111G01	1	1	1	1						
13a	T2 Screw	4x8, SS	7P32-0408	1	1	1	1						
14	Bushing	SR-30-1	420472-03	1	1	1	1						
15	Gasket	L=655	4A0808L02	2	2	2	2						
16	Gasket	L=190	4A0808L02	1	1	1	1						
17	Gasket	L=762	4A0808L02	1	1	1	1						
18	Silicone Hose	L=310	773013812	1	1	1	1						
19	Bulb Holder	-	3A3903-01		1	1	1						
19a	Thumbscrew	SS, ABS	415949G11		2	2	2						
19b	NSF Plate	-	4A4401G01		1	1	1						

**B. Refrigeration Circuit**  
**KML-451MAH**  
 R-0 to T-0, T-2, U-0

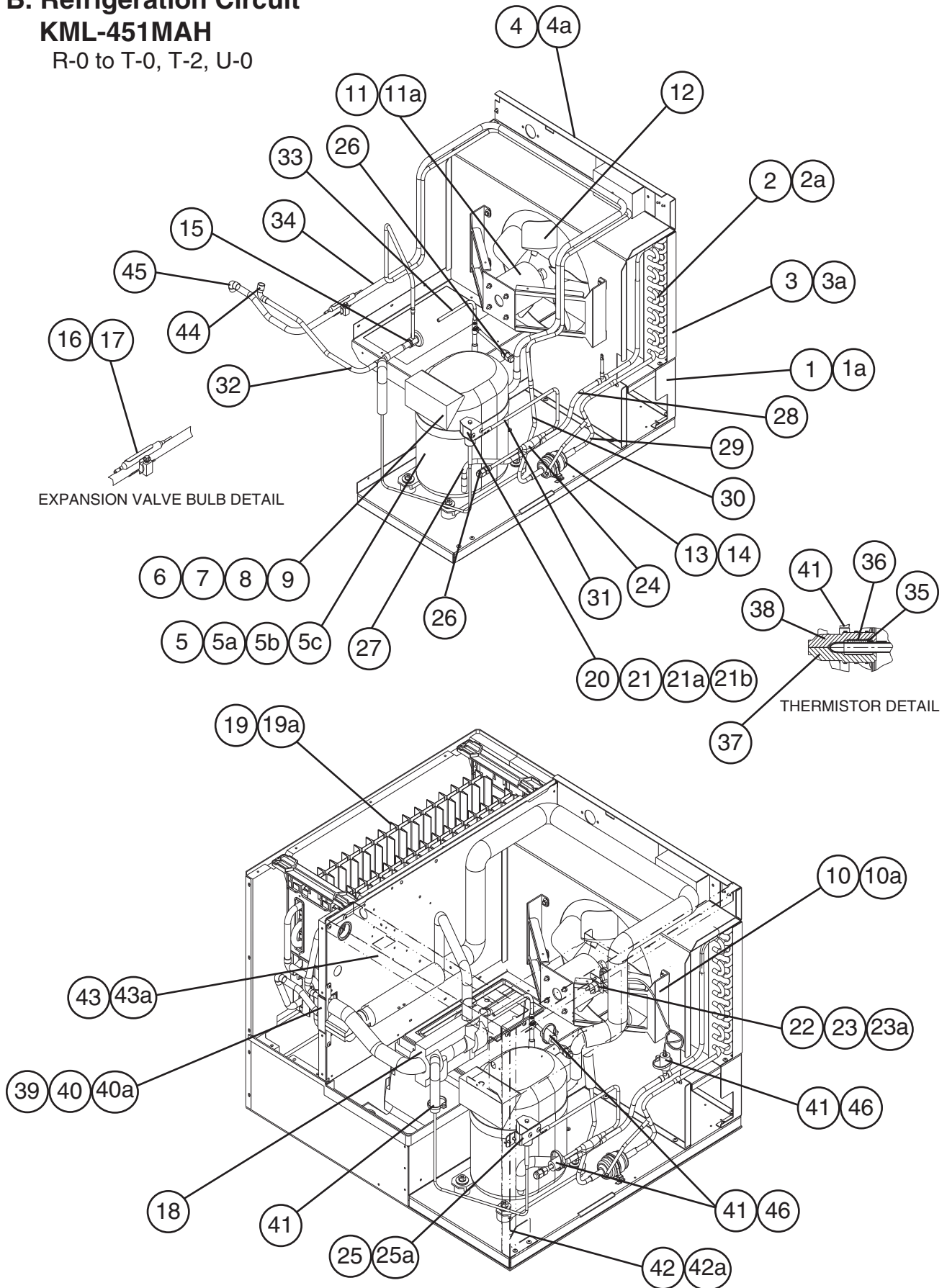

# B. Refrigeration Circuit

## KML-451MAH

T-1, U-1

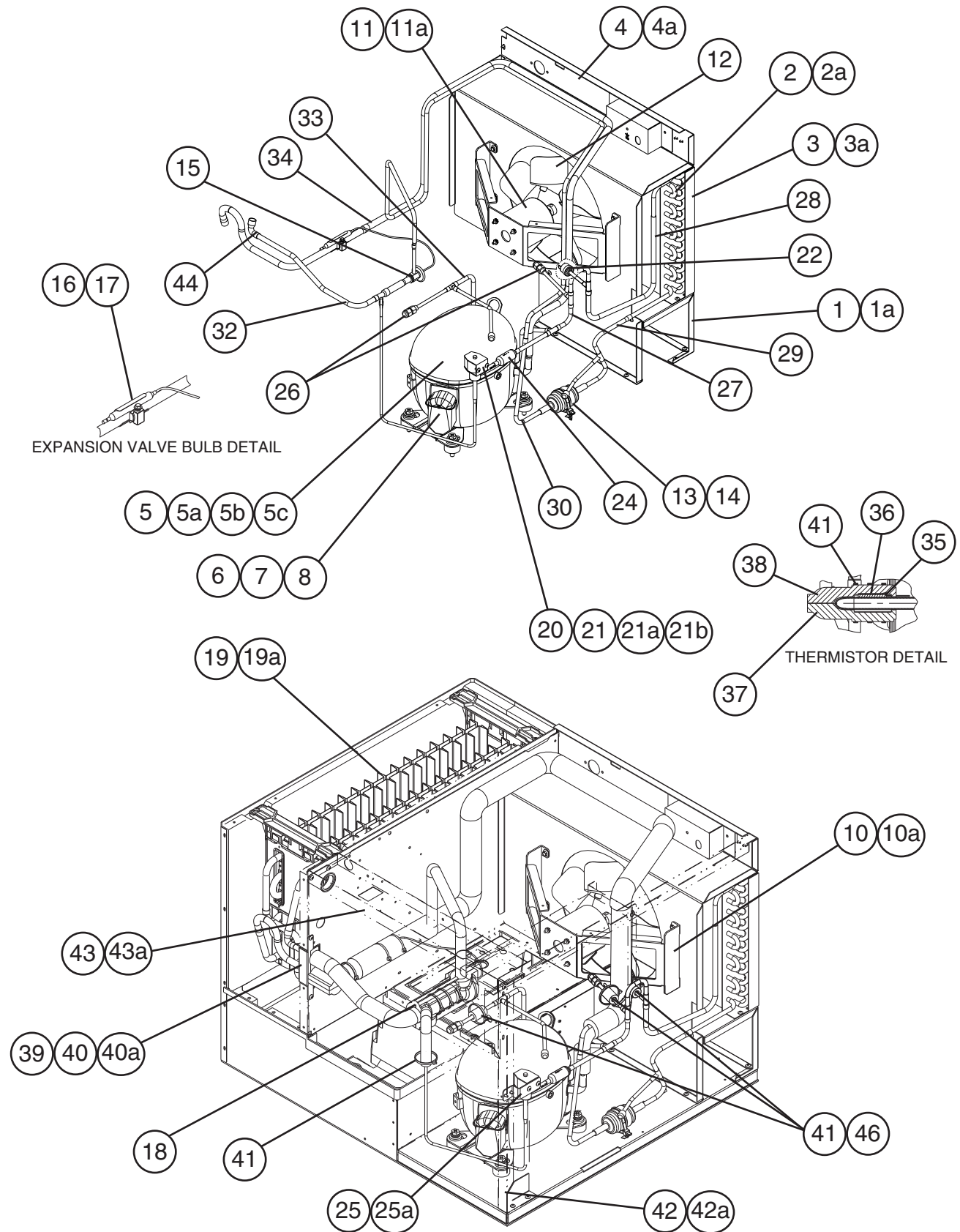

Title: <b>B. Refrigeration Circuit</b> Model: <b>KML-451MAH</b>											
Index No.	Description	Material or Model Number	Part Number	Required Number							
				R-0 to T-2 U-0	T-1 U-1						
1	Condenser Support	GS	3A3870-01	1	1						
1a	T2 Screw	4x8	7P31-0408	5	5						
2	Condenser	S-0799	2A0640-01	1	1						
2a	T2 Screw	4x8	7P31-0408	3	3						
3	Barrier	GS	4A0932-01	1	1						
3a	T2 Screw	4x8	7P31-0408	2	2						
4	Shroud	GS	3A0597G02	1	1						
4a	T2 Screw	4x8	7P31-0408	7	5						
5	Compressor	RS43C2E-CAA-219	4A2300-01	1	-						
		RST45C1E-CAA-202	4A4479-01		1						
5a	Spacer	-	434404-01	4	-						
			4A2595-01		4						
5b	Grommet	-	434403-01	4	-						
			4A2593-01		4						
5c	Bolt	8x45	437889-01	4	4						
6	Terminal Cover	-	4A2300F01	1	-						
			4A4479F01		1						
7	Spring Clip	-	4A2300F02	1	-						
			4A4479F02		1						
8	Protector	-	4A1805-01	1	-						
			4A4481-01		1						
9	Protector Holder	-	437339-01	1	-						
10	Fan Motor Bracket	GS	3A3967-01	1	1						
10a	Hex Head Bolt w/Washer (LF)	5x12	7B0130512	4	4						
11	Fan Motor	5KCP84 DFK148S	4A3158-01	1	1						
11a	Self Locking Nut	NO. 8-32	7N2110832	4	4						
12	Fan Blade	AD10CW40	4A4014-01	1	1						
13	Drier	C-03E126	4A2666-01	1	1						
14	Nylon Tie	PLWP3H-TL	8911-0301	1	1						
15	Expansion Valve	HFE-10NHDU-4	4A4008-01	1	-						
		HFE-10NHDU-3	4A1684-01		1						
16	Holder/Expansion Valve-3/8	SS	3A0107-01	1	1						
17	Clamp	SS	443461-02	1	1						
18	Expansion Valve Cover	PE FOAM	3A0944-01	1	1						
19	Evaporator Assembly	-	2A0717G01	1	1						
19a	T2 Screw	4x16	7P31-0416	4	4						
20	Valve Body-Hot Gas	ATS-B7SHDU-2	4A3978-01	1	1						
21	Coil-Valve	AMS-C12HDU-3	4A3277-01	1	1						
21a	Bolt	-	4A3277F01	1	1						
21b	Truss Head Screw	4x8	7C31-0408	2	2						
22	Pressure Switch	ACB-1UB09	433441-07	1	-						
		ACB-1UB44	463180-04		1						

Title: <b>B. Refrigeration Circuit</b> Model: <b>KML-451MAH</b>												
Index No.	Description	Material or Model Number	Part Number	Required Number								
				R-0 to T-2 U-0	T-1 U-1							
23	Pressure Switch Bracket	GS	434938-01	1	-							
23a	T2 Screw	4x8	7P31-0408	1	-							
24	Strainer	-	4A0397-01	1	-							
			441569-02		1							
25	Bracket	GS	4A1406-01	1	1							
25a	T2 Screw	4x8	7P31-0408	2	2							
26	Access Valve	TCJ-2F20NHDU-1	457729-01	2	2							
27	Copper Tube (A)-High Side	Copper	3A3789G01	1	-							
			2A4919G01		1							
28	Copper Tube (C)-High Side	Copper	3A3790G01	1	-							
	Copper Tube (B)-High Side		3A5164-01		1							
29	Copper Tube (D)-High Side	Copper	3A3788G01	1	1							
30	Copper Tube (E)-High Side	Copper	3A3783-01	1	-							
			4A4693-01		1							
31	Copper Tube (A)-Hot Gas	Copper	4A1878-01	1	-							
32	Copper Tube (B)-Hot Gas	Copper	2A3691G01	1	1							
33	Copper Tube (A)-Access Valve	Copper	3A3974G01	1	-							
	Copper Tube-Access Valve		3A4783G01		1							
34	Heat Exchanger	Copper	2A3685G01	1	-							
			2A4894G01		1							
35	Thermistor	-	429006-03	1	1							
36	Holder-Thermistor	Copper	427430-01	1	1							
37	Insulation-Thermistor (A)	PE FOAM	439368-01	1	1							
38	Insulation-Thermistor (B)	PE FOAM	439368-02	1	1							
39	Insulated Rubber Tube	EPDM	4A1008G01	1	1							
40	Insulation Holder	SS	3A1084-01	1	-							
			4A3902-01		1							
40a	T2 Screw	4x8	7P31-0408	2	2							
41	Cable Tie	PLT2S-M	8911-0200	12	14							
42	Frame (A)	GS	2A0645-01	1	1							
42a	T2 Screw	4x8	7P31-0408	4	4							
43	Frame (B)	GS	3A0595-01	1	1							
43a	T2 Screw	4x8	7P31-0408	4	4							
44	Elbow	COPPER	4A1059-01	1	1							
45	Elbow	COPPER	417395-03	1	-							
46	Insulation Tube	L=30	7762-1020	3	3							

**B. Refrigeration Circuit**  
**KML-451MWH**  
 R-0 to U-0

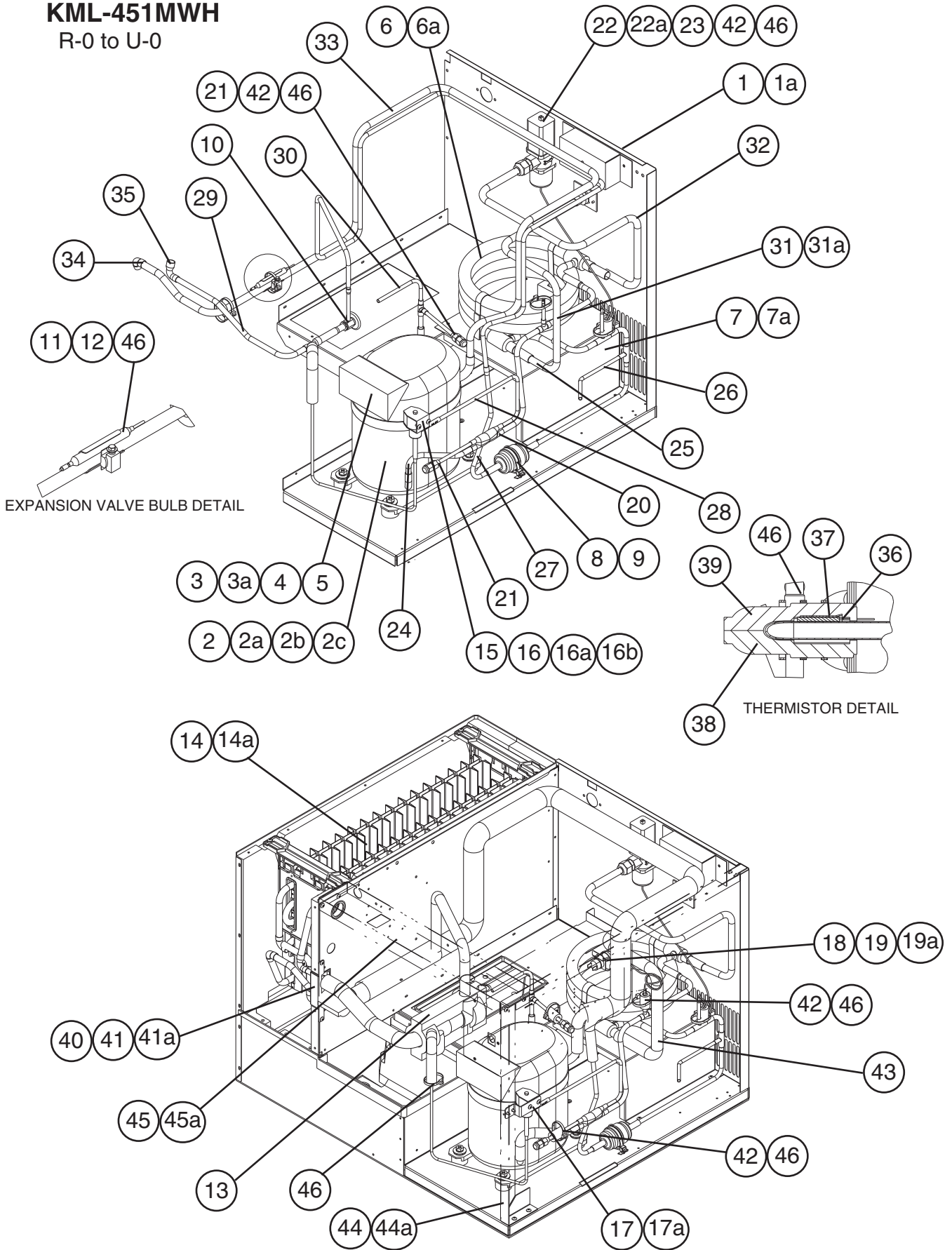



# B. Refrigeration Circuit

## KML-451MWH

U-1

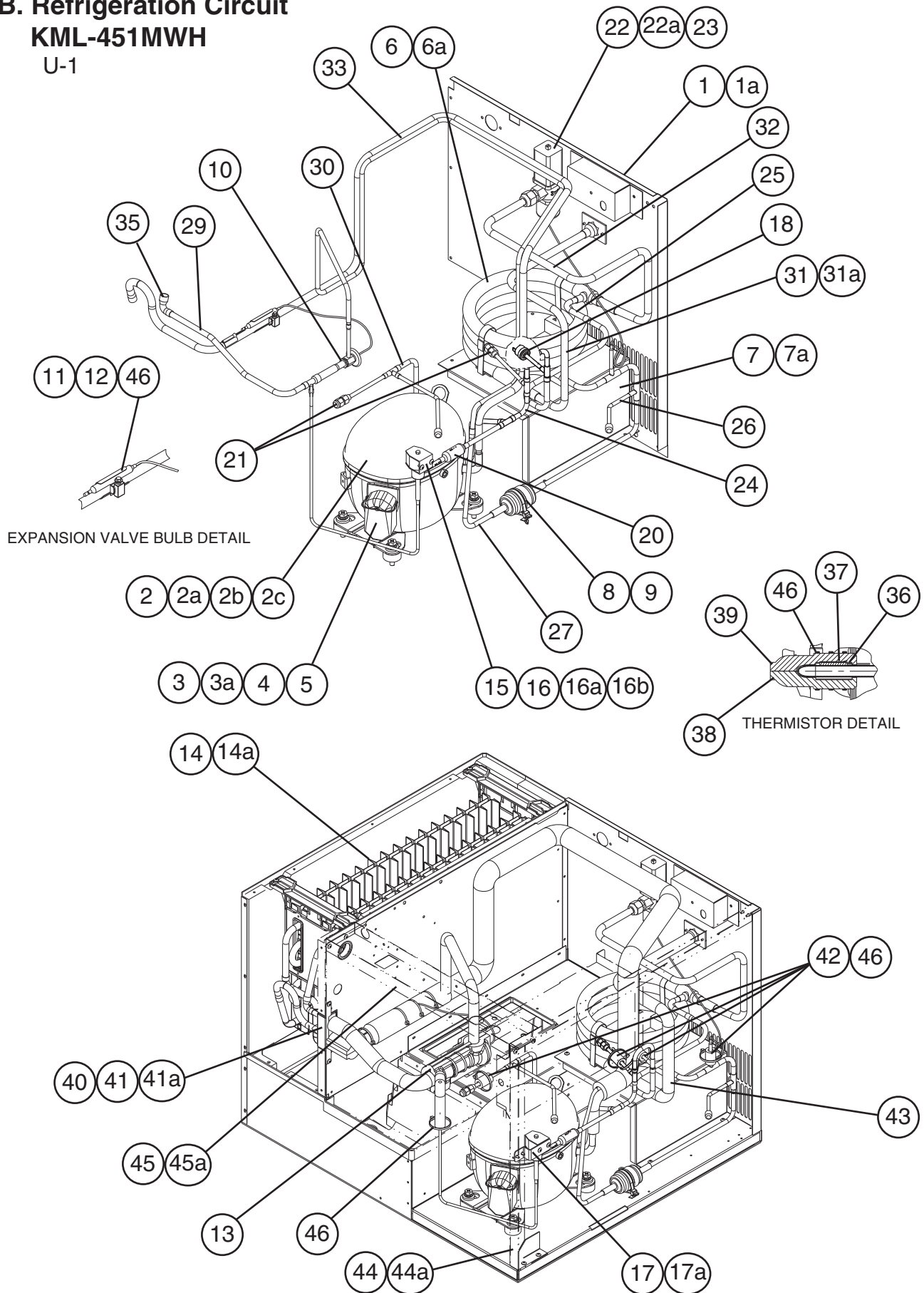

Title: <b>B. Refrigeration Circuit</b> Model: <b>KML-451MWH</b>											
Index No.	Description	Material or Model Number	Part Number	Required Number							
				R-0 to U-0	U-1						
1	Rear Panel (B)	GS	3A0630G03	1	1						
1a	T2 Screw	4x8	7P31-0408	9	9						
2	Compressor	RS43C2E-CAA-219	4A2300-01	1	-						
		RST55C1E-CAA-202	4A4376-01		1						
2a	Spacer	-	434404-01	4	-						
			4A2595-01		4						
2b	Grommet	-	434403-01	4	-						
			4A2593-01		4						
2c	Bolt	8x45	437889-01	4	4						
3	Terminal Cover	-	4A2300F01	1	-						
			4A4376F01		1						
3a	Spring Clip	-	4A2300F02	1	-						
			4A4376F02		1						
4	Protector	-	4A1805-01	1	-						
			4A2634-02		1						
5	Protector Holder	-	437339-01	1	-						
6	Condenser	HS-0160	2A2359G01	1	1						
6a	Hex Head Bolt w/Washer (LF)	5x12	7B0130512	2	2						
7	Condenser Support	GS	2A2367-01	1	1						
7a	T2 Screw	4x8	7P31-0408	4	4						
8	Drier	C-03E126	4A2666-01	1	1						
9	Nylon Tie	PLWP3H-TL	8911-0301	1	1						
10	Expansion Valve	HFE-10NHDU-4	4A4008-01	1	-						
		HFE-10NHDU-3	4A1684-01		1						
11	Holder/Expansion Valve 3/8	SS	3A0107-01	1	1						
12	Clamp	SS	443461-02	1	1						
13	Expansion Valve Cover	PE FOAM	3A0944-01	1	1						
14	Evaporator Assembly	-	2A0717G01	1	1						
14a	T2 Screw	SS, 4x16	7P32-0416	4	4						
15	Valve Body-Hot Gas	ATS-B7SHDU-2	4A3978-01	1	1						
16	Coil-Valve	AMS-C12HDU-3	4A3277-01	1	1						
16a	Bolt	-	4A3277F01	1	1						
16b	Truss Head Screw	4x8	7C31-0408	2	2						
17	Bracket	GS	4A1406-01	1	1						
17a	T2 Screw	4x8	7P31-0408	2	2						
18	Pressure Switch	ACB-2UB04	433441-05	1	-						
		ACB-1UB43	463180-05		1						
19	Pressure Switch Bracket	GS	434938-01	1	-						
19a	T2 Screw	4x8	7P31-0408	1	-						
20	Strainer	-	4A0397-01	1	-						
			441569-02		1						
21	Access Valve	-	457729-01	2	2						
22	Water Regulator	V46DA-6	4A0911-06	1	1						
22a	Truss Head Screw	4x6	7C31-0406	2	2						



Title: <b>B. Refrigeration Circuit</b> Model: <b>KML-451MWH</b>												
Index No.	Description	Material or Model Number	Part Number	Required Number								
				R-0 to U-0	U-1							
23	Male Connector	BRASS	4A1087-01	1	1							
24	Copper Tube (A)-High Side	Copper	3A3789G01	1	-							
			2A4919G01		1							
25	Copper Tube (B)-High Side	Copper	3A3812G01	1	-							
			3A5165-01		1							
26	Copper Tube (C)-High Side	Copper	3A3813G01	1	1							
27	Copper Tube (E)-High Side	Copper	3A3783-01	1	-							
			4A4693-01		1							
28	Copper Tube (A)-Hot Gas	Copper	4A1878-01	1	-							
29	Copper Tube (B)-Hot Gas	Copper	2A3691G01	1	1							
30	Copper Tube (A)-Access Valve	Copper	3A3974G01	1	-							
	Copper Tube-Access Valve		3A4783G01		1							
31	Copper Tube (A)	Copper	3A2174G01	1	1							
31a	T2 Screw	4x8	7P31-0408	2	2							
32	Copper Tube (B)	Copper	3A2149G01	1	1							
33	Heat Exchanger	Copper	2A3685G01	1	-							
			2A4894G01		1							
34	Elbow	Copper	417395-03	1	-							
35	Elbow	Copper	4A1059-01	1	1							
36	Thermistor	-	429006-03	1	1							
37	Holder-Thermistor	Copper	427430-01	1	1							
38	Insulation-Thermistor (A)	PE Foam	439368-01	1	1							
39	Insulation-Thermistor (B)	PE Foam	439368-02	1	1							
40	Insulated Rubber Tube	EPDM	4A1008G01	1	1							
41	Insulation Holder	SS	3A1084-01	1	-							
			4A3902-01		1							
41a	T2 Screw	4x8 SS	7P32-0408	2	2							
42	Insulation Tube	L=30	7762-1020	4	4							
43	Insulation Tube	L=800	7762-1323	1	1							
44	Frame (A)	GS	2A0645-01	1	1							
44a	T2 Screw	4x8	7P31-0408	4	4							
45	Frame (B)	GS	3A0595-01	1	1							
45a	T2 Screw	4x8	7P31-0408	4	4							
46	Cable Tie	PLT2S-M	8911-0200	13	15							

**C. Water Circuit**  
**KML-451MAH, KML-451MWH**  
 R-0 to U-1 (A-G)

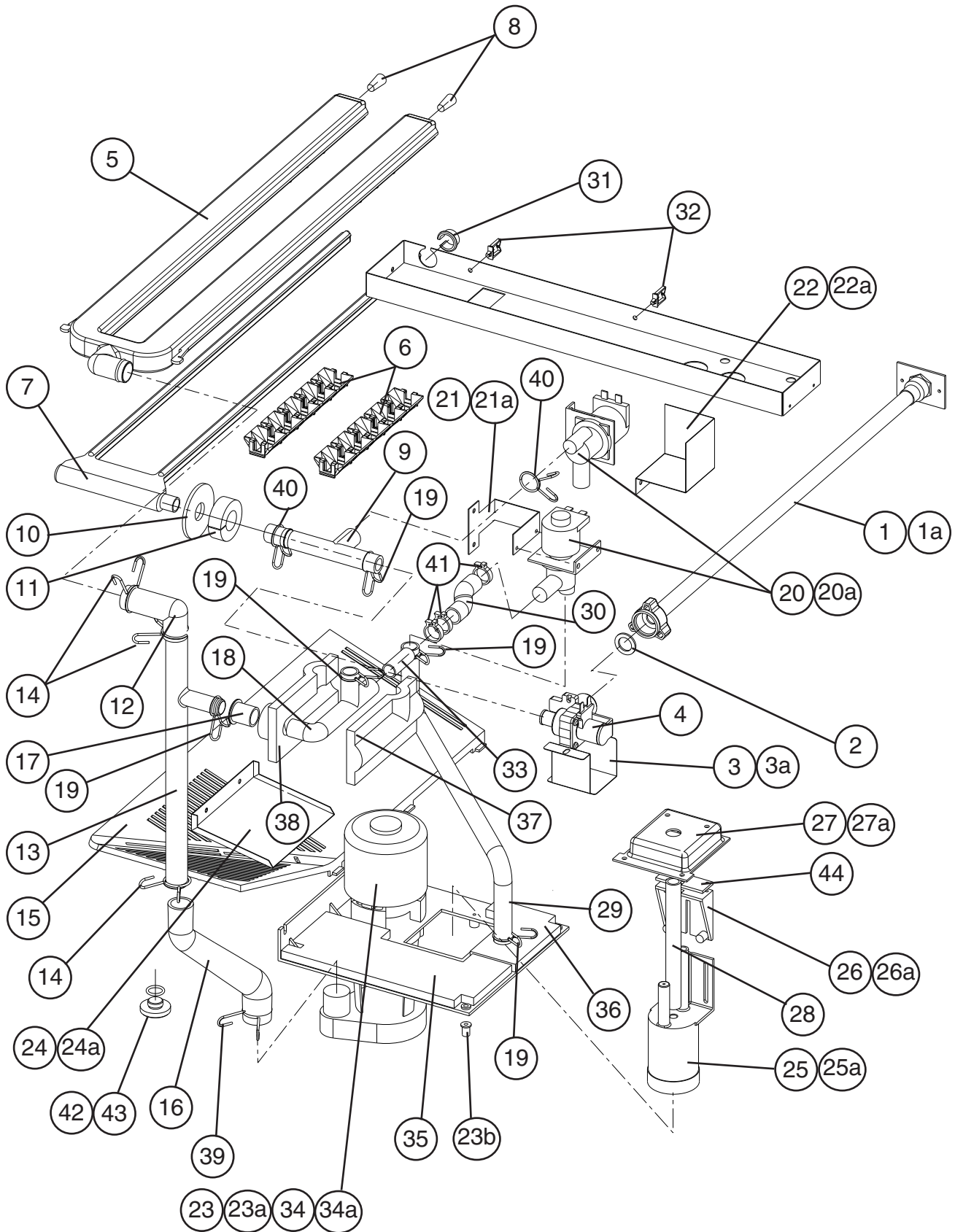

**C. Water Circuit**  
**KML-451MAH, KML-451MWH**  
 U-1 (H & later)

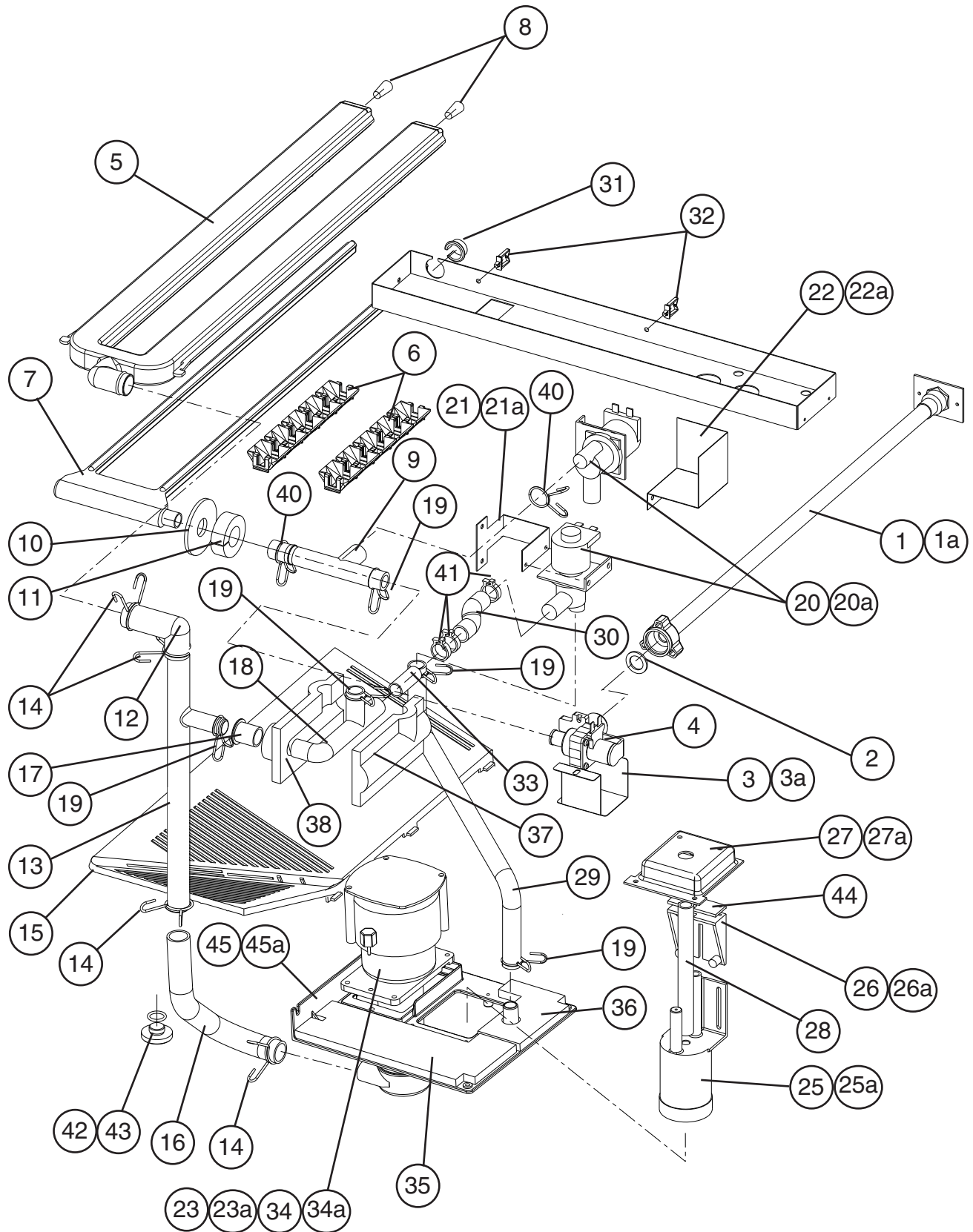

Title: **C. Water Circuit** Model: **KML-451MAH, KML-451MWH**

Index No.	Description	Material or Model Number	Part Number	Required Number								
				R-0 S-1	S-2 T-0	T-1	U-0	U-1 (A-G)	U-1 (H-M)			
1	Water Supply Pipe	COPPER	4A0768G04	1	1	1	1	1	1			
1a	T2 Screw	4x8	7P31-0408	2	2	2	2	2	2			
2	Rubber Gasket	NR	413854-03	1	1	1	1	1	1			
3	Water Valve Bracket	GS	321443-01	1	1	1	1	1	1			
3a	T2 Screw	4x8	7P31-0408	1	1	1	1	1	1			
4	Water Valve	J248-647	3U0150-01	1	1	1	1	1	1			
5	Spray Tube	PE	1A0260-02	1	1	1	1	1	1			
6	Spray Guide	PE	208586-01	6	6	6	6	6	6			
7	Water Supply Tube	PE	2A0079-01	1	1	1	1	1	1			
8	Plug	-	4A0176-01	2	2	2	2	2	2			
9	Water Supply Tee	SANTOPRENE	4A1006-01	1	1	1	1	1	1			
10	Flange	EPDM	439267-01	1	1	1	1	1	1			
11	Insulation (E)	PE FOAM	4A0392-01	1	1	1	1	1	1			
12	Elbow	SANTOPRENE	4A0393-01	1	1	1	1	1	1			
13	Connecting Pipe	PE	3A1335-01	1	1	1	1	1	1			
14	Hose Clamp	SS, 25 mm	427443-03	3	3	3	3	3	4			
15	Cube Guide	ABS	2A0660-01	1	1	1	1	1	1			
16	Pump Hose	EPDM	4A1007-01	1	1	1	1	1	-			
	Vinyl Hose	L=245	7716-2025						1			
17	Rubber Ring	EPDM	4A1004-01	1	1	1	1	1	1			
18	Bypass Hose	SANTOPRENE	4A1005-01	1	1	1	1	1	1			
19	Hose Clamp	SS, 18 mm	427443-05	5	5	5	5	5	5			
20	Solenoid Valve	207CB-GS1873	439322-01	2	-							
		DSVP12N-2LSX-120A-L1SR	4A3722-01		2	2	2	2	2			
20a	Truss Head Screw	4x8	7C31-0408	4	4	4	4	4	4			
21	Solenoid Valve Bracket	-	4A3137-01	1	1	1	1	1	1			
21a	T2 Screw	4x8	7P31-0408	2	2	2	2	2	2			
22	Solenoid Cover	GS	4A0996-01	1	1	1	1	1	1			
22a	T2 Screw	4x8	7P31-0408	2	2	2	2	2	2			
23	Pump Motor	OSP-B15BEJ16	2A2861-01	1	1	1	1	1	-			
		PV-211BHZ1	4A4259-01						1			
23a	Truss Head Screw	4x16, SS	7C32-0416	4	4	4	4	4	-			
	Thumbscrew	SS, ABS	415949G11						1			
23b	Wellnut	347011	4A1070-01	2	2	2	-					
24	Barrier	-	4A2997-01	1	1	1	1	1	-			
24a	T2 Screw	4x8 SS	7P32-0408	2	2	2	2	2	-			
25	Float Switch	213095	4A3624-01	1	1	1	1	1	1			
25a	T2 Screw	4x8 SS	7P32-0408	2	2	2	2	2	2			
26	Float Switch Bracket	ABS	327757-01	1	1	1	1	1	1			
26a	T2 Screw	4x12, SS	7P32-0412	2	2	2	2	2	2			
27	Float Switch Cover	ABS	3A0665-01	1	1	1	1	1	1			
27a	T2 Screw	4x12, SS	7P32-0412	3	3	3	3	3	3			
28	Vinyl Hose	L=150	7716-1216	1	1	1	1	1	1			
29	Vinyl Hose	L=325	7716-1519	1	1	1	1	1	1			
30	Vinyl Hose	L=55	7716-1519	1	1	1	1	1	1			
31	Bushing	OCB-875	428394-04	1	1	1	1	1	1			
32	Wire Saddle	-	4A0338-02	8	8	8	8	8	8			
33	Joint Pipe	-	439329-01	1	1	1	1	1	1			

Title: <b>C. Water Circuit</b> Model: <b>KML-451MAH, KML-451MWH</b>												
Index No.	Description	Material or Model Number	Part Number	Required Number								
				R-0 S-1	S-2 T-0	T-1	U-0	U-1 (A-G)	U-1 (H-M)			
34	Tooth Washer (Pump Motor Ground)	ZINC, M4	7R21-0400	1	1	1	1	1	1			
34a	T2 Screw (Pump Motor Ground)	4x8, SS	7P31-0408	1	1	1	1	1	1			
35	Insulation (A)-Pump Motor Bracket	PE FOAM	4A1052-01	1	1	1	1	1	-			
			4A4783-01						1			
36	Insulation (B)-Pump Motor Bracket	PE FOAM	4A1053-01	1	1	1	1	1	1			
37	Insulation (A1)-Bypass Hose	NP	4A1259-01	1	1	1	1	1	1			
38	Insulation (A2)-Bypass Hose	NP	4A1260-01	1	1	1	1	1	1			
39	Hose Clamp	SS, 27 mm	427443-08	1	1	1	1	1	-			
40	Hose Clamp	SS, 20 mm	427443-06	2	2	2	2	2	2			
41	Hose Clamp	-	4A2017-06	3	-							
		SS, 18 mm	427443-05		3	3	3	3	3			
42	Drain	POLYACETAL	309246-01	1	1	1	1	1	1			
43	"O" Ring	1AP15	7611-P015	1	1	1	1	1	1			
44	Float Switch Spacer	ABS	4A0650-01			1	-	1	1			
45	Pump Bracket	-	2A4920G01						1			
45a	Truss Head Screw	4x16, SS	7C32-0416						4			

**D. Control Box Assembly**  
**KML-451MAH, KML-451MWH**  
 R-0 to U-1

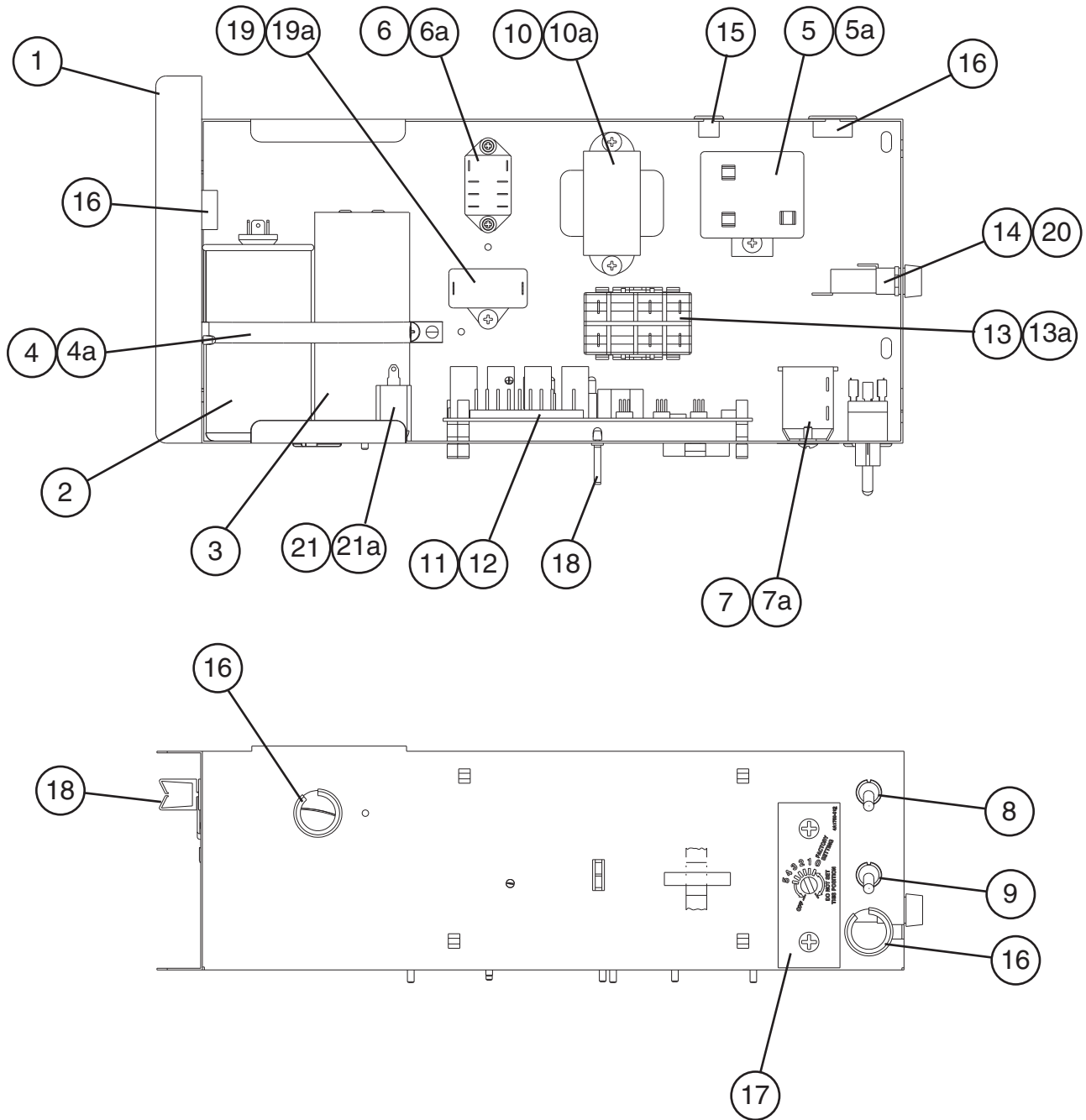

Title: <b>D. Control Box Assembly</b> Model: <b>KML-451MAH, KML-451MWH</b>											
Index No.	Description	Material or Model Number	Part Number	Required Number							
				R-0 to T-2 U-0	T-1 U-1 (A-G)	U-1 (H-M)					
1	Control Box	GS	3A2372G02	1	1	1					
2	Capacitor-Run	15MFD, 370 VAC	3A2005-08	1	-						
		35MFD, 440 VAC	3A2005-12		1	1					
3	Capacitor-Start	243-292MFD, 115 VAC	3A0076-10	1	-						
		243-292MFD, 165 VAC	3A0076-20		1	1					
4	Strap	GS	4A2262-03	1	1	1					
4a	T2 Screw	4x8	7P31-0408	1	1	1					
5	Starter	3ARR3KC5M5	4A1107-11	1	1	1					
5a	T2 Screw	4x8	7P31-0408	1	1	1					
6	Relay-Drain	LY2F 120 VAC	406132-07	1	1	1					
6a	Tapping Screw	3x8	431415-01	2	2	2					
7	Thermostat	YTB-3U112	4A2879-01	1	1	1					
7a	Truss Head Screw	4x8	7C31-0408	2	2	2					
8	Toggle Switch	8966K84	443119-01	1	1	1					
9	Toggle Switch	8966K211	4A0985-01	1	1	1					
10	Transformer	26D285H	3A0172-01	1	1	1					
10a	T2 Screw	4x8	7P31-0408	2	2	2					
11	Control Board	HOS001A	2A1410-01	1	1	1					
12	Board Support	CBLS37-M	4A0336-03	4	4	4					
13	Magnetic Contactor	VC20	428393-01	1	1	1					
13a	T2 Screw	4x8	7P31-0408	2	2	2					
14	Fuse	AGC-10	4A0893-07	2	2	2					
15	Bushing	OCB-500	428394-02	1	1	1					
16	Bushing	OCB-875	428394-04	4	4	4					
17	Control Label	PES FILM	4A1758-01	1	1	1					
18	Wire Saddle	VWS4238-C	4A0338-02	2	2	2					
19	Capacitor-Fan Motor	<b>KML-451MAH</b> 5 MFD, 250 VAC	443192-02	1	1	1					
19a	T2 Screw	<b>KML-451MAH</b> 4x8	7P31-0408	1	1	1					
20	Fuse Holder	HTB 82I	4A3449-01	1	1	1					
21	Capacitor-Pump Motor	2.5 MFD, 250 VAC	4A2128-05			1					
21a	T2 Screw	4x8	7P31-0408			1					

**E. Label Location**  
**KML-451MAH**  
 R-0 to U-1

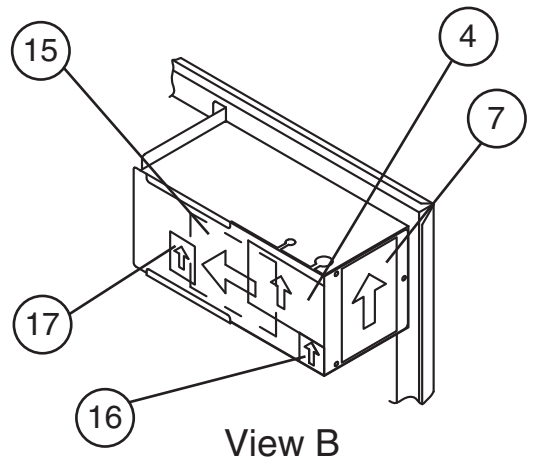
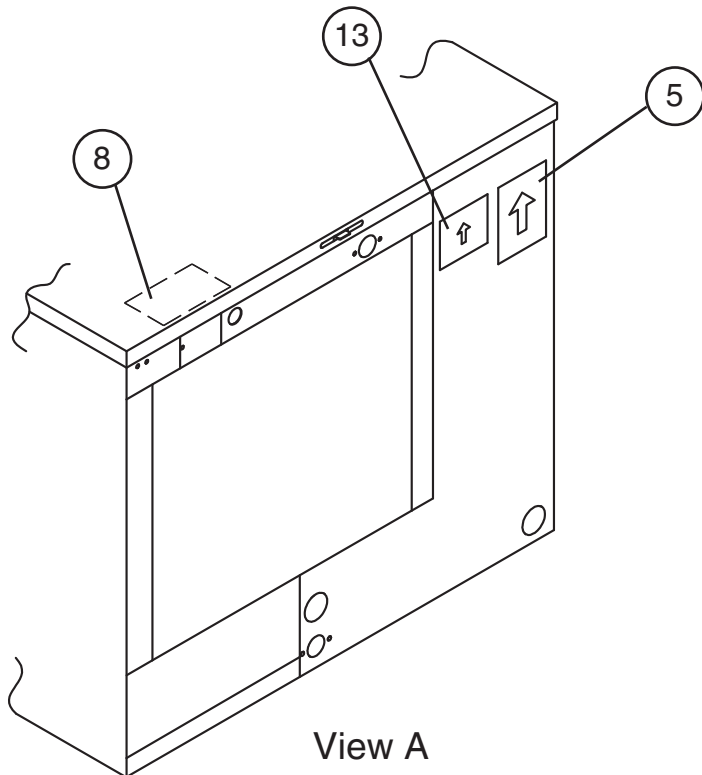
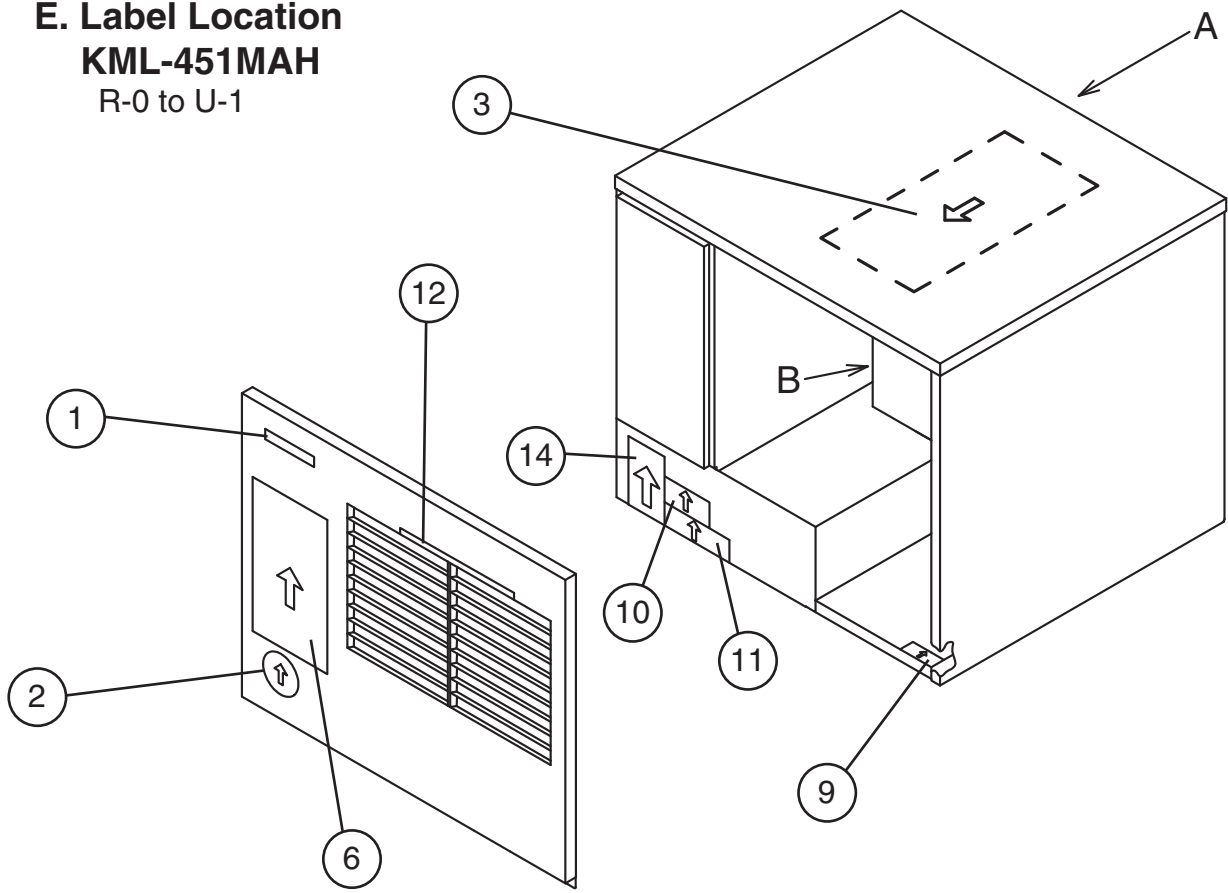



Title: <b>E. Label Location</b> Model: <b>KML-451MAH</b>												
Index No.	Description	Material or Model Number	Part Number	Required Number								
				R-0 to T-2 U-0	T-1	U-1						
1	Emblem	PETP FILM	4A0560-01	1	1	1						
2	Label-Penguin-HA (R)	PETP FILM	4A0526-01	1	1	1						
3	Maintenance Label	PVC FILM	3A3940-01	1	-							
			3A4471-01		1	1						
4	Wiring Label	PVC FILM	3A3914-01	1	-							
			3A5157-01		1	-						
			3A5478-01			1						
5	Nameplate	PES FILM	2A3800-01	1	-							
			2A4899-01		1	-						
			2A5195-01			1						
6	Instruction Sheet	PAPER	2A2156-01	1	-							
7	Manual Label	PVC FILM	4A2863-01	1	1	1						
8	Tag-Warning: Electrical Connection	PAPER	435005-01	1	1	1						
9	Label-R404A	PES FILM	4A0960-01	1	1	1						
10	Caution Label (F)	PVC FILM	439146-01	1	1	1						
11	Caution Label (K)	PVC FILM	439150-01	1	1	1						
12	Label-Air Filter	PETP FILM	426177-01	1	1	1						
13	Instruction Label	PVC FILM	444575-01	1	1	1						
14	Rating Label	PES FILM	2A3801-01	1	-							
			2A4900-01		1	-						
			2A5194-01			1						
15	Label-Control Board	PVC FILM	3A2220-01	1	1	1						
16	Label-Fuse	PVC Film	4A2817-01	1	1	1						
17	Label-Alarm	PVC Film	4A3517-01	1	1	1						

**E. Label Location**  
**KML-451MWH**  
R-0 to U-1

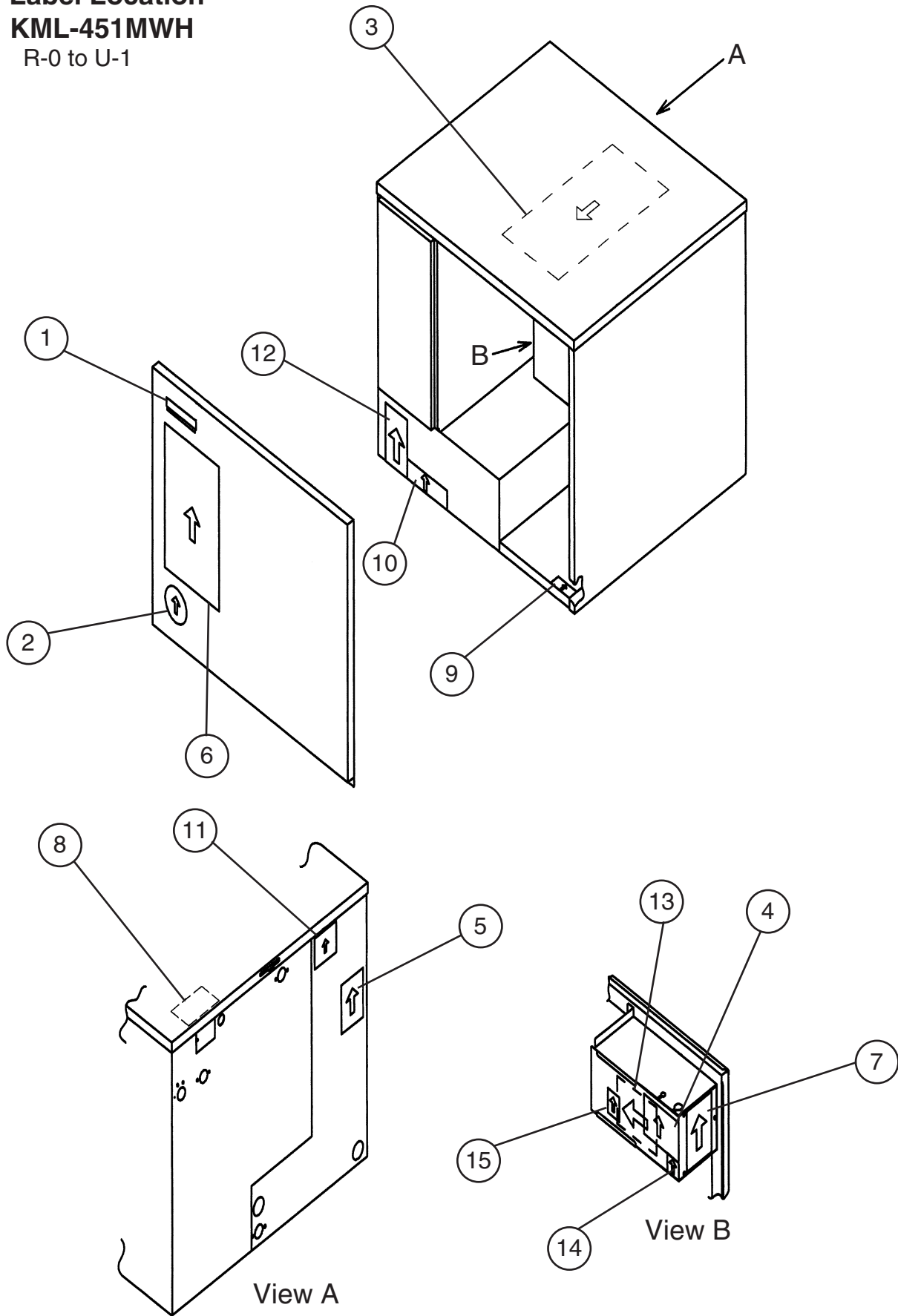

Title: <b>E. Label Location</b> Model: <b>KML-451MWH</b>											
Index No.	Description	Material or Model Number	Part Number	Required Number							
				R-0 to U-0	U-1 (A-G)	U-1 (H-M)					
1	Emblem	PETP FILM	4A0560-01	1	1	1					
2	Label-Penguin-HA (R)	PETP FILM	4A0526-01	1	1	1					
3	Maintenance Label	PVC FILM	3A3940-01	1	-						
			3A4471-01		1	1					
4	Wiring Label	PVC FILM	3A3914-01	1	-						
			3A5157-01		1	-					
			3A5478-01			1					
5	Nameplate	PES FILM	2A3800-02	1	-						
			2A4899-02		1	-					
			2A5195-02			1					
6	Instruction Sheet	PAPER	2A2156-01	1	-						
7	Manual Label	PVC FILM	4A2863-01	1	1	1					
8	Tag-Warning: Electrical Connection	PAPER	435005-01	1	1	1					
9	Label-R404A	PES FILM	4A0960-01	1	1	1					
10	Caution Label (K)	PVC FILM	439150-01	1	1	1					
11	Instruction Label	PVC FILM	444575-01	1	1	1					
12	Rating Label	PES FILM	2A3801-02	1	-						
			2A4900-02		1	-					
			2A5194-02			1					
13	Label-Control Board	PES FILM	3A2220-01	1	1	1					
14	Label-Fuse	PVC Film	4A2817-01	1	1	1					
15	Label-Alarm	PVC Film	4A3517-01	1	1	1					

**F. Top Panel Assembly**  
**KML-451MAH, KML-451MWH**  
 R-0 to U-1

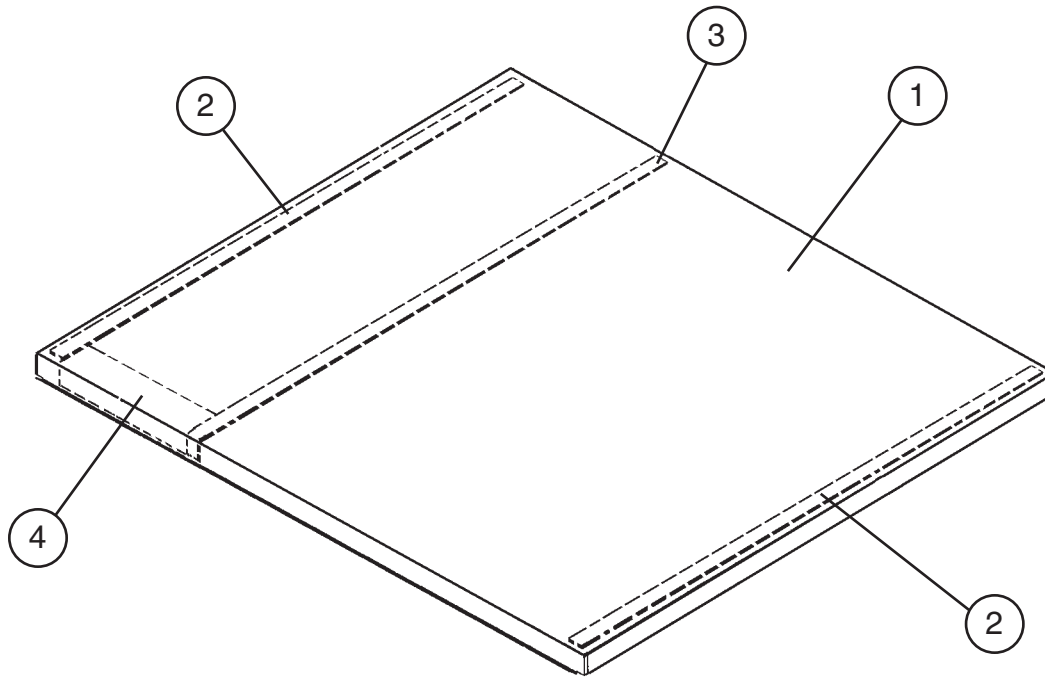

Title: <b>F. Top Panel Assembly</b> Model: <b>KML-451MAH, KML-451MWH</b>										
Index No.	Description	Material or Model Number	Part Number	Required Number						
				R-0 to U-1						
1	Top Panel	SS	2A2110-01	1						
2	Gasket	PVC	427014-04	2						
3	Gasket (A)	NORMOUNT V710	324859-03	1						
4	Insulation	PE FOAM	438012-01	1						

**G. Front Panel Assembly**  
**KML-451MAH, KM-451MWH**  
 R-0 to U-1

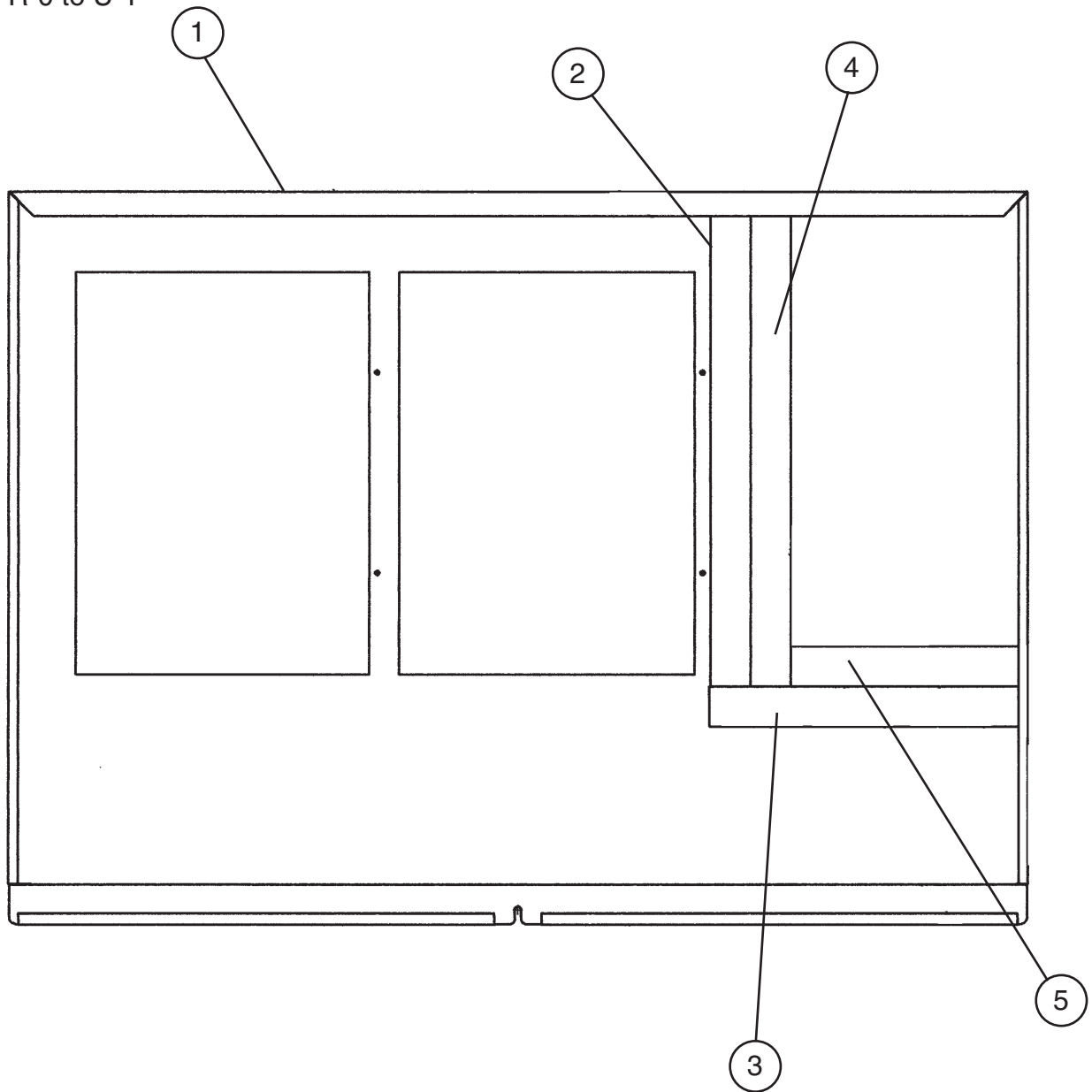

Title: <b>G. Front Panel Assembly</b> Model: <b>KML-451MAH, KML-451MWH</b>											
Index No.	Description	Material or Model Number	Part Number	R-0 to U-1	Required Number						
1	Front Panel (A)	<b>KML-451MAH</b>	2A2107-01	1							
		<b>KML-451MWH</b> SS	2A2107-02	1							
2	Foam Seal	L=370	4A0661L01	1							
3	Foam Seal	L=250	4A0661L01	1							
4	Foam Seal	L=370	4A1163L01	1							
5	Foam Seal	L=190	4A1163L01	1							

**H. Accessories & Packaging**  
**KML-451MAH, KML-451MWH**  
R-0 to U-1

Title: <b>H. Accessories &amp; Packaging</b> Model: <b>KML-451MAH, KML-451MWH</b>												
Index No.	Description	Material or Model Number	Part Number	Required Number								
				R-0 to U-1								
1	Instruction Manual	PAPER	91A1BG10C	1								
2	Universal Brace	GS	4A0363-01	2								
2a	Hex Head Bolt	5x12, SS	7B02-0512	2								
-	Packaging	-	2A2126A01									

## Free Manuals Download Website

<http://myh66.com>

<http://usermanuals.us>

<http://www.somanuals.com>

<http://www.4manuals.cc>

<http://www.manual-lib.com>

<http://www.404manual.com>

<http://www.luxmanual.com>

<http://aubethermostatmanual.com>

Golf course search by state

<http://golfingnear.com>

Email search by domain

<http://emailbydomain.com>

Auto manuals search

<http://auto.somanuals.com>

TV manuals search

<http://tv.somanuals.com>