

# *SAFE USE AND CARE OF YOUR APPLIANCE*

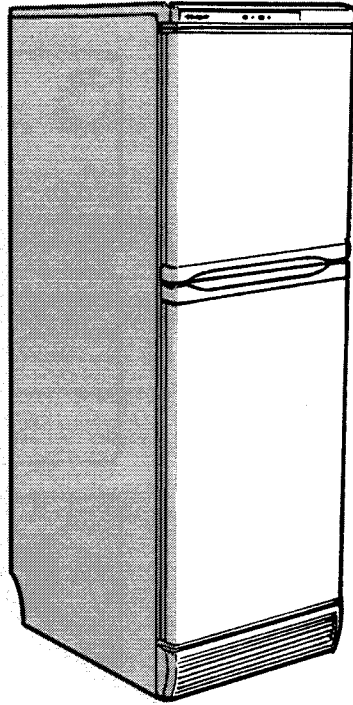

**MISTRAL PLUS**

*MODEL FF50*

**For your own safety and to get the best results, it is important you read right through this handbook before using your appliance for the first time.**

***Hotpoint***<sup>®</sup>

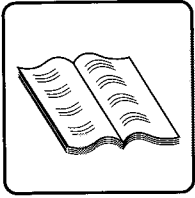

# Contents

## Section

Electrical Connections

Installing your Appliance

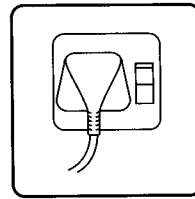

Getting to know your Appliance

Controlling your Appliance

**Model no. FF50**

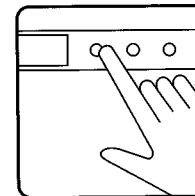
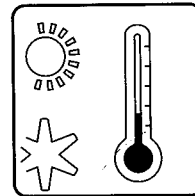

Making the best use of your Appliance

Food storage times and positions

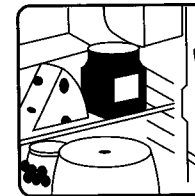

Cleaning

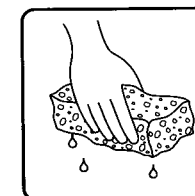

Maintenance

Problem Solving

Important Information

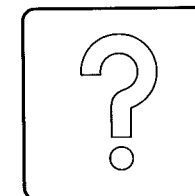

Service Cover

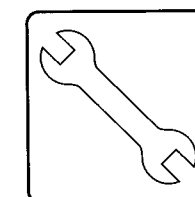

Changing the doors from right-hand  
to left-hand hinging

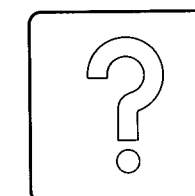

# Electrical connections

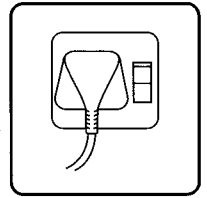

## SUPPLY

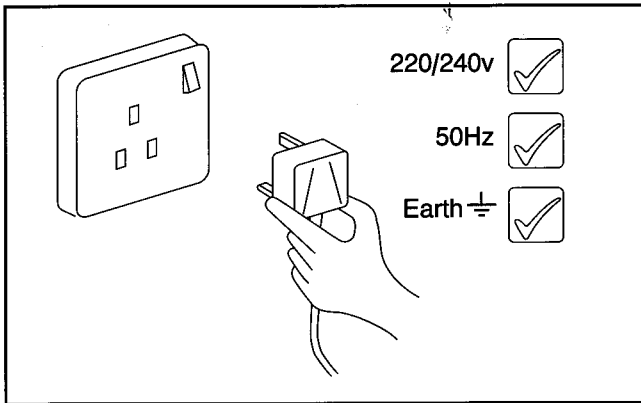

This appliance should be connected directly to the mains supply via a suitably switched socket in an accessible position.



**WARNING: THIS APPLIANCE MUST BE EARTHED.**

**IMPORTANT:** DO NOT use 'POWER' saving devices in conjunction with this appliance as it may affect the performance of the appliance.

## FUSES

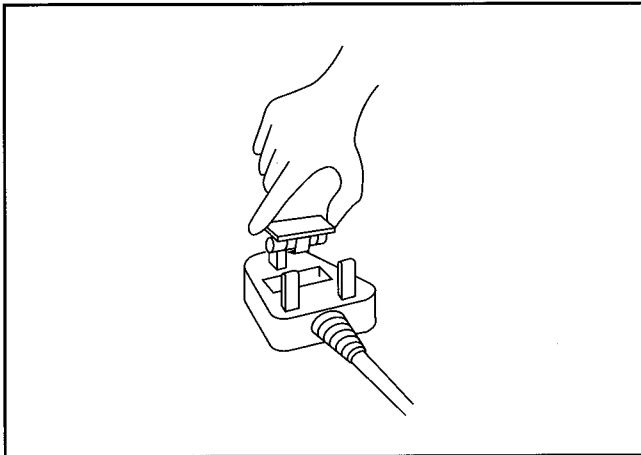

Your Hotpoint appliance comes fitted with a plug and 13A fuse. Only fuses rated at 13 amp and ASTA approved to BS1362 should be used if you need a replacement.

The fuse cover **MUST** be refitted when changing the fuse.



**WARNING: DO NOT USE PLUG WITHOUT THE FUSE COVER FITTED**

If the fuse cover is lost, a replacement can be obtained from you local Hotpoint Service office or Electricity Company. The correct replacement is identified by colour coding or marking on the base of the plug.

## CHANGING THE PLUG

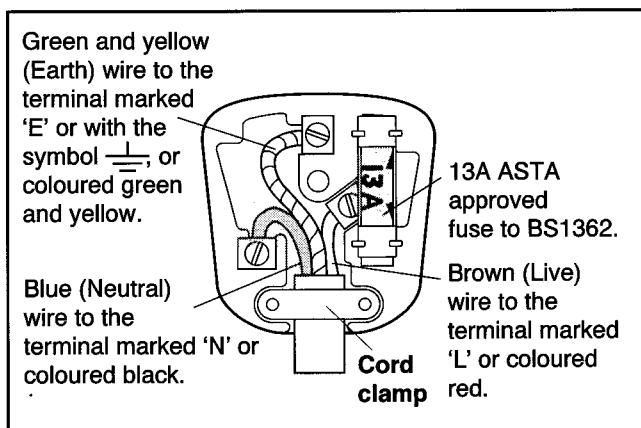

**WARNING: DO NOT INSERT THIS PLUG INTO A SOCKET ELSEWHERE AS THIS COULD CAUSE A SHOCK HAZARD.**

**IMPORTANT:** THE WIRES IN THE MAINS LEAD ARE COLOURED IN ACCORDANCE WITH THE FOLLOWING CODE:

Green/yellow	–	Earth
Blue	–	Neutral
Brown	–	Live

If you change the plug the colours of the wires in the mains lead may not correspond with the colours of the markings identifying the terminals in your plug. You should therefore wire it as shown (see illustration).

If the mains lead needs replacing at any time, it must be replaced by a special lead obtainable from your Hotpoint Service Office.

A charge will be made if you have damaged the existing lead or require longer lead.

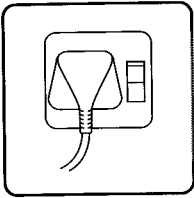

## Installing your appliance

### SAFETY



**WARNING: WHEN DISCARDING YOUR OLD FRIDGE OR FREEZER BE CERTAIN TO MAKE THE LOCK UNUSABLE, OR IF POSSIBLE, REMOVE THE DOORS AND DISCARD SEPARATELY.**

Children could become trapped.



**WARNING: DO NOT ALLOW CHILDREN TO PLAY OR TAMPER WITH THE APPLIANCE.**



**WARNING: DO NOT ATTEMPT TO SIT OR STAND ON TOP OF YOUR APPLIANCE; IT IS NOT DESIGNED FOR SUCH USE.**

You could injure yourself or damage the appliance.

### POSITIONING AND FOOT ADJUSTMENT

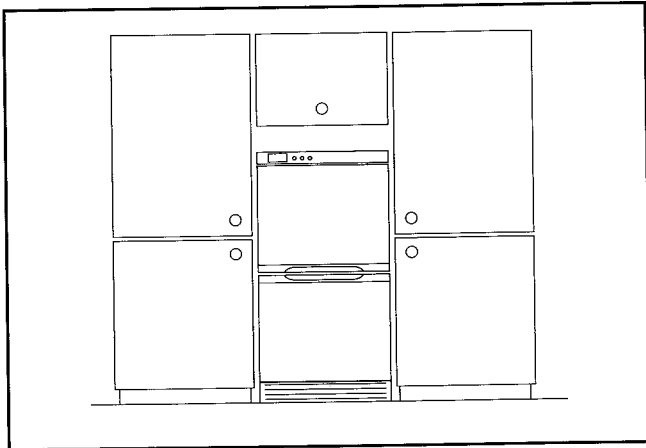

You should choose the position of your appliance carefully, as it will influence how well it performs...

POSITION THE APPLIANCE AWAY FROM HEAT SOURCES eg. Cookers, Radiators, Direct Sunlight

Heat will make the appliance work harder, cost more to run and may shorten its working life

IT IS ADVISABLE TO LEAVE A SMALL GAP BETWEEN THE BACK OF THE APPLIANCE AND THE WALL

This will help to reduce the risk of condensation.

### ADJUSTING THE FEET

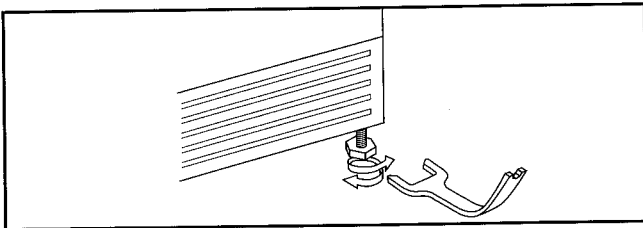

ENSURE THAT THE FEET ARE ADJUSTED, USING THE SPANNER PROVIDED, TO LEVEL THE APPLIANCE AND PREVENT IT ROCKING

If the appliance is not level the door and seal alignment may be adversely affected

### STARTING

**NOTE:** The appliance should be allowed to stand for two hours before switching on if it has been moved, in the horizontal position, at delivery, or, prior to placing in the correct working position. Insert the plug into the socket outlet and switch on the electricity supply. There may be a short delay before the compressor (motor) starts. It will take up to 2 hours, after switching on, to achieve recommended temperature

### CLEANING

Before using your appliance it is advisable to wipe the interior and exterior in a bicarbonate of soda/water solution. (See section on Cleaning towards the rear of the handbook)

The appliance should then be dried with a clean cloth.

# Getting to know your appliance

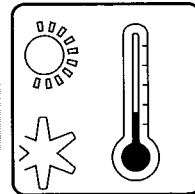

## HOW IT WORKS

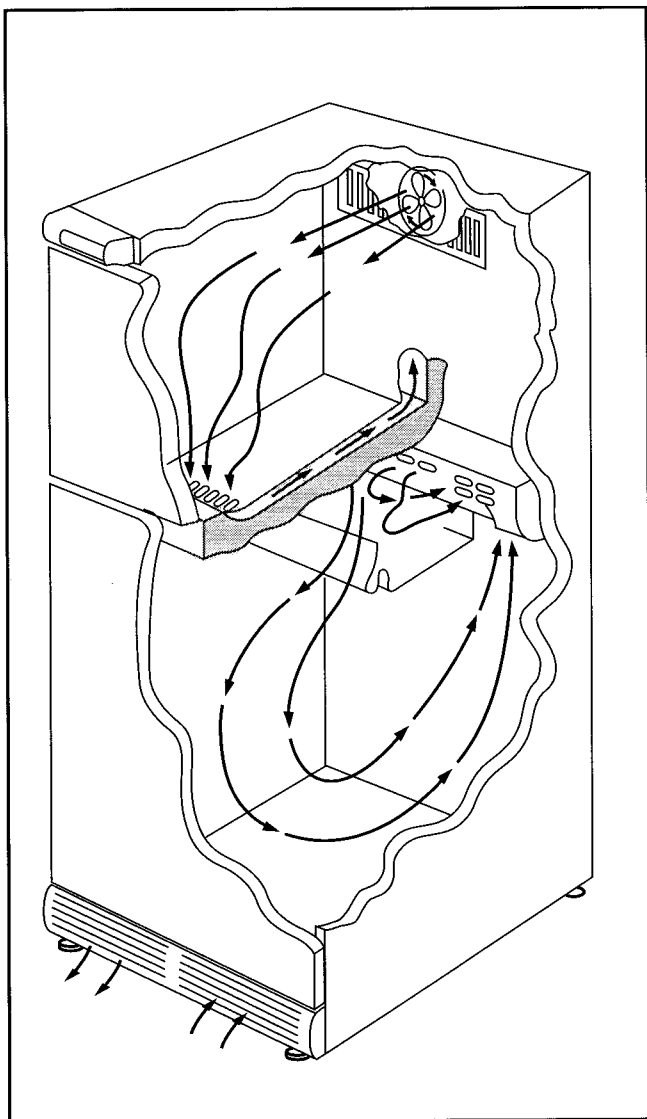

Your appliance works by using a refrigeration system to remove heat from food and drink placed inside, thereby cooling them.

The heat is transferred to the surrounding area by a compressor circulating refrigerant (liquid). The heat generated in this process is expelled into the air.

(You can sometimes hear the refrigerant circulating.)

On a conventional appliance frost forms on the cooling surfaces inside, and will form more quickly if the door is opened frequently or if foods are left uncovered.

This frost has to be removed periodically in order to maintain the efficient operation of the appliance ('Defrosting').

On a FROST-FREE model the cooling surfaces inside are hidden from view, and the cold air circulated by a fan. (See diagram.) This gives an even temperature and rapid cooling.

The heat generated in the refrigeration process is expelled through a grille at the base front of the appliance. (See diagram.)

**NOTE:** You should be careful not to obstruct this grille.

You may notice that the front edge of the cabinet is sometimes warm, this is normal and is part of the refrigerant circulating system designed to help prevent condensation on the door seal.

## BENEFITS OF 'FROST-FREE'

- No defrosting ever
- No ice = More space for food
- Improved temperature control
- Better food preservation
- Frozen food packs do not adhere together
- Quicker temperature recovery after door opening
- Even temperature

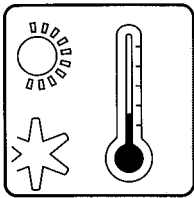

# Model no. FF50 **Getting to know your appliance**

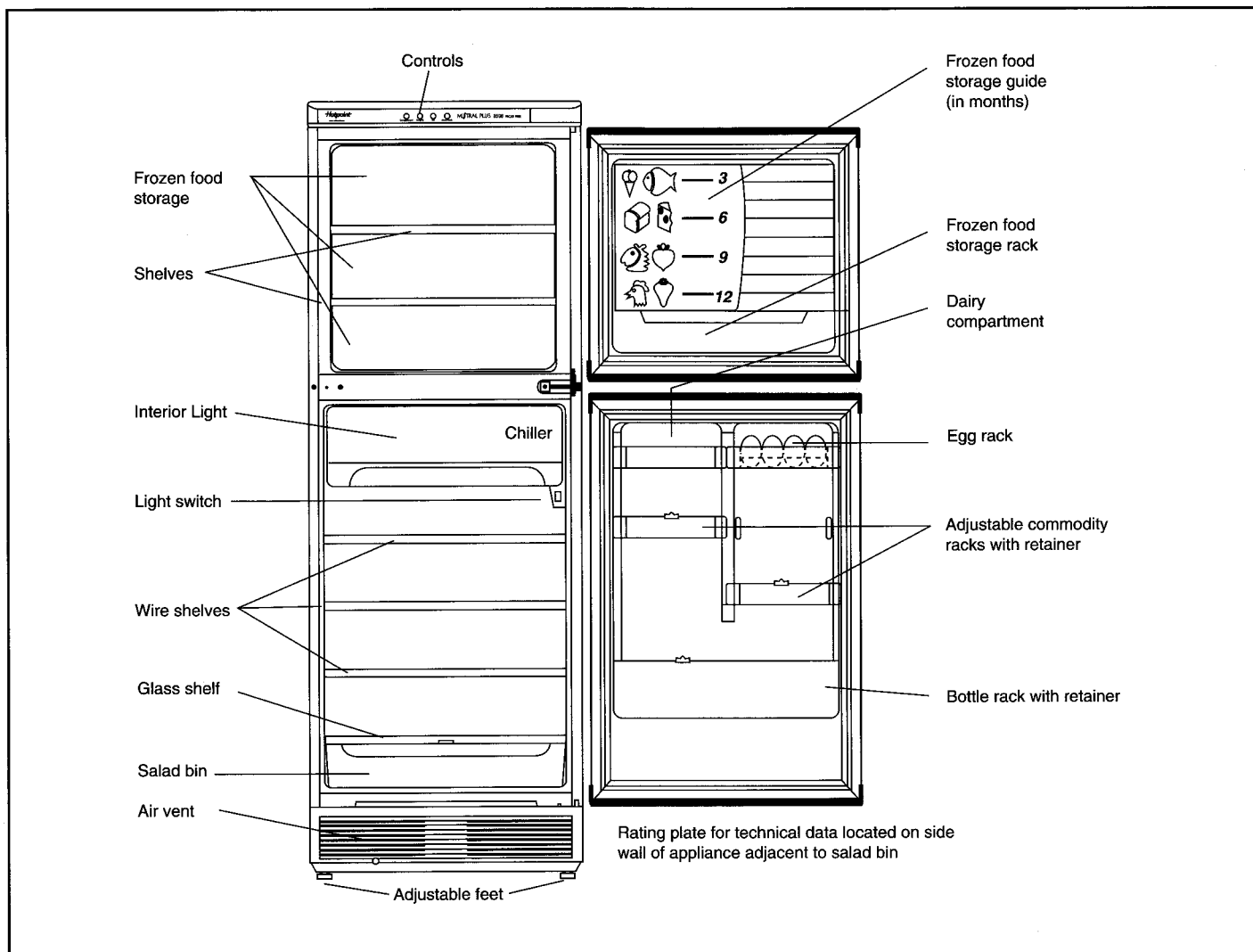

# Controlling your appliance

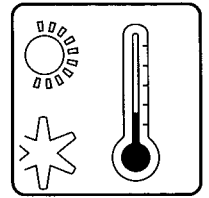

## COMPARTMENT TEMPERATURES

Fridge	(0 to +6°C)
Freezer	(-18 to -24°C) not adjustable

Your appliance has 2 main compartments.

Temperature specified in these zones are food temperatures. (Air temperatures will vary rapidly if the door is opened, or depending on where it is measured.)

The appliance comes with temperatures set in the factory for optimum performance under typical operating conditions.

## CHANGING THE FRIDGE TEMPERATURE

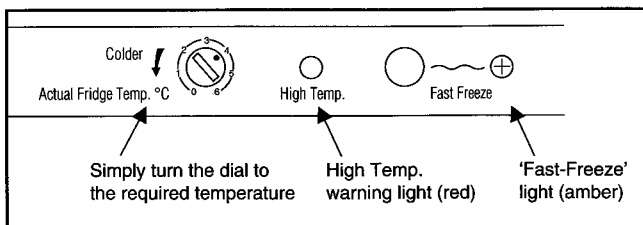

If for any reason you wish to alter the fridge temperature simply turn the dial until the 'dot' is adjacent to the required temperature.

**Note:** You cannot change the freezer temperature.

## USING 'FAST-FREEZE'

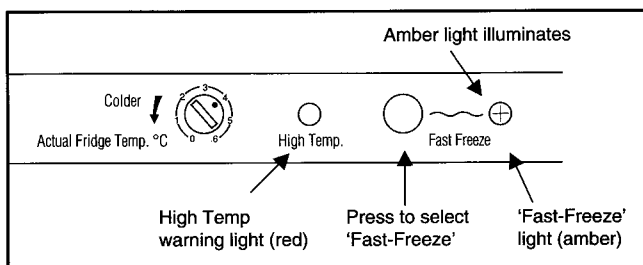

Wait at least 2 hours after initially starting appliance before selecting 'FAST-FREEZE'. When you wish to freeze the maximum quantity of fresh food you should select 'Fast-freeze' 24 hours PRIOR to loading the food onto the TOP SHELF. EMPTY the top shelf prior to placing the fresh food. For freezing smaller quantities of food (under 1/2 the quantity) turn on the Fast-freeze when you load and switch off after a few hours. Do NOT place any fresh food to be frozen in contact with any already frozen food.

Press the Fast-freeze button to switch on or off.

**NOTE:** This Fast-freeze function will automatically cancel after 48 hours if you forget to switch it off.

## WARNINGS

### High temperature warning

The red light comes on when the temperature inside the fridge or freezer compartment rises above the correct storage temperature. If it comes on for a short period when you open the freezer compartment door to load or unload food, storage times will not be affected. If the red light stays on this indicates that something is wrong. First check that neither door has been accidentally left open.

### Error warning

If the red light flashes on and off at 1sec intervals the appliance needs attention – Refer to 'If you need help'. See Important Information page.

**NOTE:** In the event of a power failure the food will keep safely for up to 13 hours if the door is unopened. See Important Information.

## HUMIDITY CONTROL

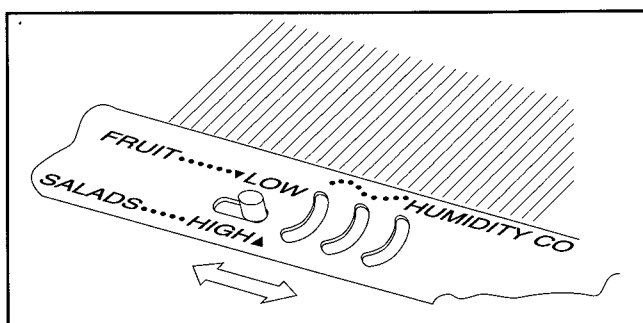

You can control the humidity of the air in the salad bins to suit the storage of either FRUIT or SALADS.

Simply change the setting of the vent at the front of the salad bin. It is recommended that SALADS are stored at high humidity and FRUIT at low humidity.

**NOTE:** If high humidity is selected condensation may form in the salad bin. The bin should be wiped dry periodically or kitchen towel placed in the floor of the salad bin and replaced at regular intervals.

Condensation in the bin may be avoided by opening the vent to a lower humidity setting.

Any fruit/salads/vegetables can be stored in the salad bin. Adjust the humidity to suit your requirements.

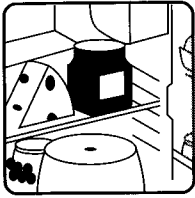

## Making the best use of your appliance

To ensure that your appliance operates as efficiently as possible, it is advisable to adhere to the recommendations below and on the following page.

### FRIDGE

#### Adjustable shelves

Reposition to allow storage of large and /or a quantity of containers.  
Do not cover or obstruct cold air flow.  
Use food in rotation and before 'use by' dates.  
Do not consume food which has been stored for an excessive time.

#### Commodity racks

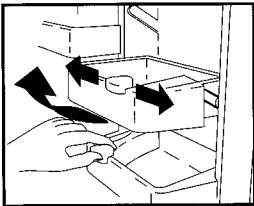

Can be adjusted to suit the items being stored e.g. dressings, salad cream, jams etc. plus butter; spreads; cheeses etc. Pull outwards and upwards to remove. These are tight fitting within the door liners to enable heavy items or a quantity of items to be stored.  
Don't use eggs cold. Bring to room temperature before use.  
Wipe, don't wash eggs.  
Retainers – where applicable – pinch and slide into position.

#### Salad bin

Store fruit, vegetables and salad items.  
Clean regularly.  
Remove unusable leaves on vegetables; remove any soil.  
Leave lettuce, cabbage, parsley and cauliflower on the stem.

#### Bottle rack

For storage of tall or short bottles depending upon the position of Commodity Racks.  
The sliding retainer position can be adjusted to hold bottles, containers etc firmly.

#### Chiller

Store fresh meat, bacon, fish etc at chilled temperatures.  
Select chilled food last when shopping. Transport home in a cool bag.  
**DO NOT STORE FOODS WITH A HIGH WATER CONTENT** e.g. SALAD FOODS.  
**Note:** The chiller compartment will maintain very cold temperatures. For some items, e.g. cooked meats, it may be necessary to remove from the chiller a short while before serving.

### FOOD STORAGE

Wrap cheese in greaseproof, place in polythene bag. Bring to room temperature before use.  
Wrap all foods thoroughly to prevent drying out except if stored in the salad bins.  
Wrap raw meat and poultry loosely in polythene or foil.  
Place foods with a strong odour in an airtight container.  
Chill drinks before consumption.  
Store raw meat/poultry below cooked foods.  
Package raw and cooked food separately.  
Cool cooked food before placing in fridge.  
**Don't** let defrosting food juices drip onto food being stored.  
**Don't** store poisonous/dangerous substances in the fridge. Your appliance has been designed for the storage of foodstuffs only.  
Store items in the recommended positions.  
Store items such as chicken, meat, fish, game etc in the chiller.



# Making the best use of your appliance

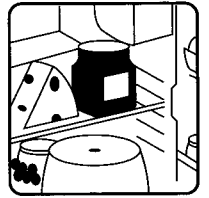

To ensure that your appliance operates as efficiently as possible, it is advisable to adhere to the recommendations below.

## **FREEZER**

Fast freezing capacity 12kg/24hours

Frozen food storage capacity 32kg } at 0.32kg/litre net storage volume.

**Fast freezing** Wait at least 2 hours after initially starting appliance before selecting 'FAST-FREEZE'. Always choose high quality fresh food and be sure it is thoroughly clean before you freeze it. Prepare fresh food for freezing in small portions to ensure rapid freezing. Don't exceed max. freezing loads. For best results, when freezing maximum quantities, switch to 'FAST-FREEZE' (FF) up to 24 hours before loading food to be frozen. Lean foods last longer than fat foods.

Wrap all foods in aluminium foil or polythene bags and make sure any air is excluded. Keep the door shut when freezing fresh food.

**Frozen Food Storage** Wrap frozen food when you buy it and put it into the freezer compartment as soon as possible. Empty and refill the ice tray periodically to ensure freshness and fit the lid. Store commercially frozen food in accordance with the instructions given by the manufacturer. Always defrost frozen foods before cooking unless instructions on the packet state otherwise. Ensure that fresh food which is frozen, is well labelled and dated. Select frozen food last when shopping. Transport home in a cool bag. Ice cream should be removed from the freezer 15-30 minutes before serving.

**Don't** leave the door open for long periods as this will make the freezer compartment more costly to run.

**Don't** put liquid-filled bottles or sealed cans containing carbonated liquids (fizzy drinks, etc) into the freezer or chiller compartments as they may burst.

**Don't** keep frozen food which has thawed; eat within 24 hours or cook and refreeze.

**Don't** give children lollipops and water ices direct from the freezer compartment as the low temperature may cause 'freezer burns' on their lips.

**Don't** store poisonous or dangerous substances in the freezer. Your freezer has been designed for the storage of foodstuffs only.

**Don't** leave ice cubes uncovered. When freezing down and storing ice use an enclosed ice cube tray or ice bags.

If there is a power cut or breakdown

Refer to Important Information page.

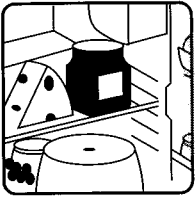

## Food storage times and positions

All foods and ice cubes should be wrapped\* or covered to prevent drying out and flavour transference with the exception of the salad bin. Plastic bags, containers with lids, foil and plastic stretch wrap are ideal.

\*Below are recommended storage times and positions within the fridge. These times are intended as a guide only. Foods which have an imminent 'use by' date MUST be consumed on or before that date.

ITEM	DAYS
<b>RAW FRESH MEAT</b> joints, steaks, chops; offal (liver/kidneys); minced meat, sausages	1
<b>COOKED MEAT</b> cooked meat; made-up dishes and left-overs	1
<b>POULTRY</b> fresh, whole (store giblets separately); giblets	1
cooked	1
<b>FISH</b> raw	1
cooked	2
<b>CHILLED FOOD</b> (Chilled food MUST be stored above any raw meat, fish or poultry)	up to best before date
<b>BACON</b> joints (cooked)	2 - 8
rashers	2 - 10
ham (unsmoked)	1 - 3
<b>NOTE:</b> The above items can be stored in the chiller where supplied.	
<b>MILK</b> pasteurised and homogenised	1 - 3
<b>CREAM</b> fresh	2
yogurt, sour cream	2 - 10
<b>BUTTER</b>	14 - 28
<b>MARGARINE AND COOKING FATS</b>	21 - 28
<b>CHEESE</b> hard	7 - 28
semi hard; blue	7 - 14
cream; cottage	7
<b>EGGS</b> shell	7 - 28
hard boiled	1 - 3
<b>VEGETABLES</b>	2 - 14
<b>SALAD/FRUIT</b> (store, where possible in the Humidity/salad bins provided)	
vegetables	2 - 14
prepared salads	1 - 3
<b>PRESERVES</b> jam, curds; marmalades; spreads; salad dressings; sauces	Follow manufacturer's 'best before/use by' date as stated on these items

**NOTE:** DON'T STORE BANANAS OR ONIONS IN THE FRIDGE.

# Cleaning

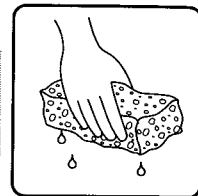

## DEFROSTING

Your appliance is a 'Frost-free' model therefore manual defrosting is not necessary, it is carried out automatically.

## CLEANING

### Removal of chiller flap

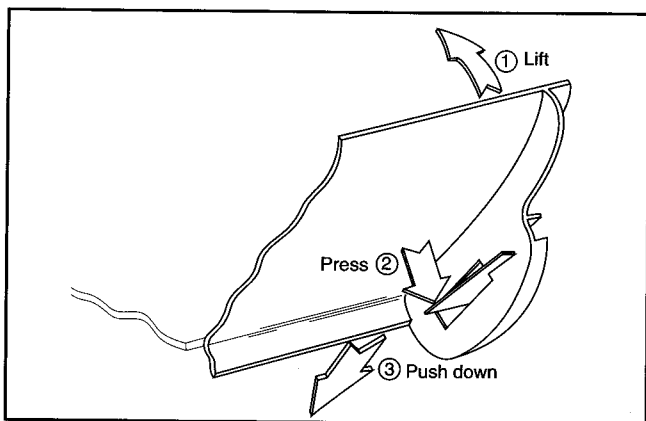

It is recommended that your appliance is cleaned periodically.

When cleaning, just follow these steps...



### **SWITCH OFF AND PULL OUT THE MAINS PLUG.**

Remove the food and wrap it or cover it to keep it cool/frozen.

Take out all of the racks and shelves from each compartment.

Remove the Chiller flap and chiller bin.

Remove salad bin from below.

Wipe out the inside of the appliance and all of the fittings with a clean cloth wrung out in a solution of Bicarbonate of Soda or Milton® and warm water.

Dry the interior thoroughly with a clean cloth before replacing the fittings and the food.

REPLACE THE MAINS PLUG AND SWITCH ON.

### Removal of freezer shelves

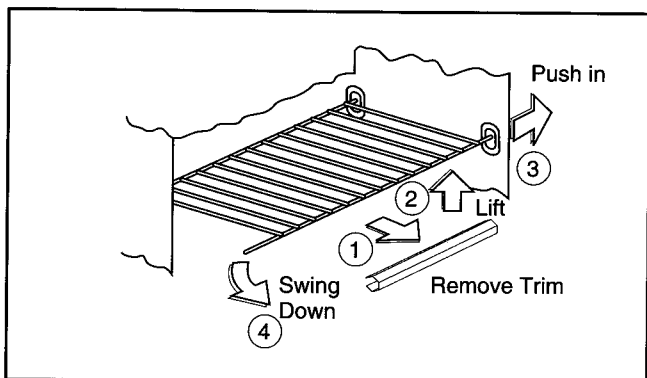

## CLEANING THE EXTERIOR



### **SWITCH OFF AND PULL OUT THE MAINS PLUG.**

Clean the exterior of the appliance using a damp cloth with a very small amount of detergent\*, followed by a wipe down with a clean dry cloth.



**\*NOTE:** DO NOT CLEAN THE DOOR SEAL WITH DETERGENT, USE SOAP AND WATER ONLY.



### **DO NOT USE ABRASIVE POWDERS.**

**NOTE:** YOU SHOULD PERIODICALLY VACUUM THE DUST FROM AROUND THE GRILLE AT THE BASE OF THE APPLIANCE TO PREVENT IT BECOMING BLOCKED.

No need to remove this grille except when changing the doors over.

SWITCH ON AGAIN.



## Maintenance

### REPLACING THE INTERIOR LIGHT

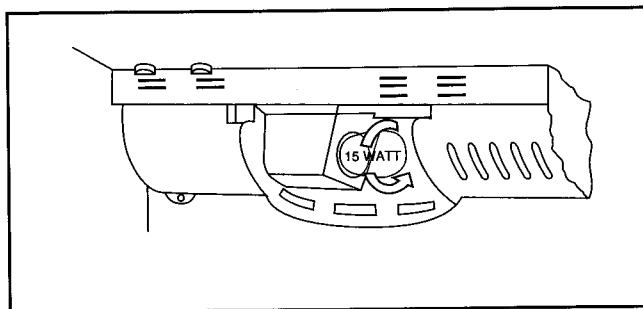
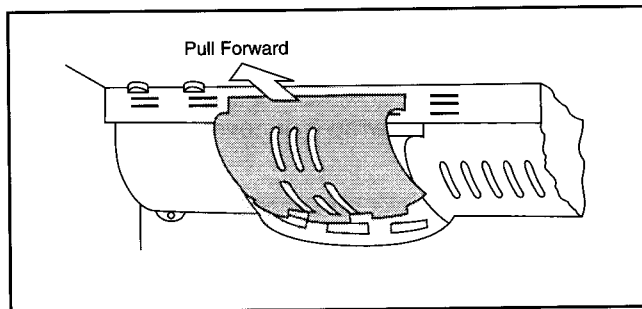
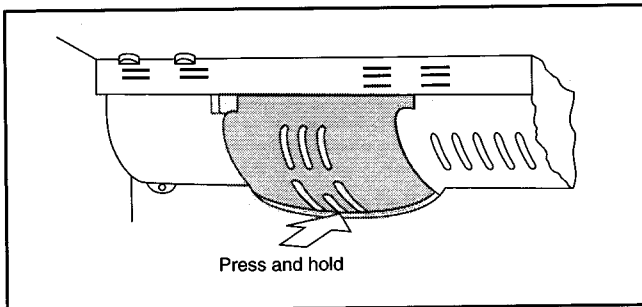

Replacement bulb – SES 15 watt only (240v)



**SWITCH OFF AND PULL OUT THE MAINS PLUG**

Press indent of lens cover to unlatch and hold.

Pull forward lens to remove.

Unscrew the bulb to remove.



**TAKE CARE IN CASE THE BULB IS HOT OR BROKEN.**

Now fit the new bulb and replace the cover.

PLUG IN AND SWITCH ON

### GOING AWAY

If you do not intend to leave the appliance on while you are away...

Switch off the electricity.

Remove the mains plug.

Remove any food.

Clean and dry the interior thoroughly.

Leave the doors slightly open.

# Problem solving



## STILL WORKING?...

Wrong temperature

Correct temperature selected?

'Fast-freeze' switched on?

Space between foodstuffs for air circulation?

Fresh food recently loaded?

Recommended freezing quantities observed?

Door left open?

Frequent door openings?

Located close to heat-source? (Cooker, Radiator, Direct Sunlight)

Hot food placed in appliance?

Grille at base of appliance blocked?

Light not working

Is there power to the appliance? – See 'NOT WORKING AT ALL'

Has the bulb blown?

## NOT WORKING AT ALL?

Is it plugged in?

Is the socket OK? (plug in another appliance to check)

Have you just switched on?

There may be a short delay before the compressor starts

Have you changed the plug? (check wiring)

Noise

If you have not had a 'Frost-free' appliance before you may notice that the appliance sounds different from your previous one.

This is because of the fan used to circulate the air around the cabinet. You may notice it running when the room is quiet.

Some noises are common to all refrigeration appliances particularly when new i.e.

– compressor noise (this takes time to run in)

– refrigerant noise (gurgles as the liquid/gas is pumped around the appliance).

These are both perfectly normal.

Are feet adjusted to make appliance steady, level and will not rock during use?

**Check the above before you call for help. See 'If you need help' section on the Important Information.**

**REMEMBER – YOU MAY BE CHARGED IF THE PROBLEM IS NOT A MECHANICAL OR ELECTRICAL BREAKDOWN!**



## Important information

### IF THERE IS A POWER CUT OR BREAKDOWN

DO NOT OPEN THE FREEZER DOOR  
Frozen food should not be affected if the failure lasts for less than:

13 hours

If the failure is longer, check the food and either use immediately or cook and refreeze.

### IF THERE IS AN ERROR WARNING RED flashing light

Up to April 1995, dial 0733 556152 and ask for Ray Osborn, thereafter contact your nearest Hotpoint Service Office (or local importer if outside the United Kingdom). The telephone number is shown on the back page.

### SPARE PARTS

Please remember your new appliance is a complex piece of equipment.

'DIY' repairs or unqualified and untrained service people may put you in danger, could damage the appliance and might mean you lose cover under Hotpoint's Parts Guarantee.

If you do experience a problem with the appliance don't take risks, contact your nearest Hotpoint Service Office (or local importer if outside the United Kingdom). The telephone number is shown on the back page. (Up to April 1995, dial 0733 556152 and ask for Ray Osborn.)

Our spare parts are designed exclusively to fit only Hotpoint appliances.



**DO NOT USE THEM FOR ANY OTHER PURPOSE. (IN DOING SO YOU MAY CREATE A SAFETY HAZARD)**

### RETENTION OF THE INSTRUCTION BOOK

This instruction book should be kept handy for reference as it contains valuable details on the safe and proper use of the appliance.

If you sell or pass on the appliance to someone else, or move house and leave it behind, please ensure you leave the book for the new owner so that they can become familiar with the appliance and use it safely and properly.

### CHANGING THE DOOR OPENING SIDE

Refer to instructions supplied at the rear of this book.

Alternatively you may wish to call an Engineer who will perform the task, for which there will be a charge.

#### If you need help...

**Note:** If you think you have a problem with the appliance always check the 'problem solving guide' first.

If after doing so you still have a problem, or if you just want advice make sure you have the following information before you call...

1. Name, Address, Post code
2. Telephone number
3. Model number, serial number and colour
4. When it was purchased
5. Clear and concise details of the query or fault.

# Service cover

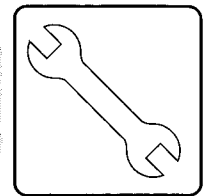

## Satisfaction Guaranteed or Your Money Back

Hotpoint gives you a unique 'Satisfaction Guaranteed' promise – valid for ninety days after you have purchased your Hotpoint product. If there is a technical problem with your Hotpoint appliance just call your Hotpoint Service Office (details in your telephone directory and the appliance instruction book). If necessary we will arrange for an engineer to call. If the technical problem is not resolved by us under this Guarantee, Hotpoint will replace your appliance or, if you prefer, give you your money back. Your statutory rights are not affected and the Guarantee is additional and subject to the terms of Hotpoint's Five Year Parts Guarantee.

## Hotpoint's Free Five Year Guarantee

From the moment your appliance is delivered, Hotpoint guarantees it for **FIVE YEARS**.

- In the Five Years all replacement parts are **FREE** provided they are fitted by our own Service Engineer. During the first year our Engineer's time and labour is also free.
- After the first year we will charge for our Engineer's time and labour. We do, however, operate a range of Service Plans (see opposite) which for an annual payment enables you to cover any repair costs which may be necessary.
- All of our service repairs are guaranteed for twelve months in respect of our labour and any parts fitted.
- The appliance must be used in the United Kingdom and must not be tampered with or taken apart by anyone other than our own Service Engineer.
- You may, however, buy parts which can be safely fitted without specialist knowledge or equipment. The correct fitting of such parts, provided they are genuine Hotpoint spares, will not affect your Guarantee. Parts are available from our main Hotpoint Spares Centres.
- Our Guarantee does not cover the cost of any repair, or loss of food in refrigeration products, due to power failure, accidents or misuse. Nor does it cover the cost of any visit to advise you on the use of the appliance. Please read thoroughly the instruction book supplied with the appliance.
- If at any time during the Guarantee period we are unable to repair your appliance, we will refund any repair costs paid to us in the previous twelve months. We will also offer you a new appliance at a reduced charge instead of a repair.
- Our Guarantee is in addition to and does not affect your legal rights.
- Should you need independent advice on your consumer rights, help is available from your Consumer Advice Centre, Law Centre, Trading Standards Department and Citizens Advice Bureau.
- All Hotpoint servicing is done by our own Service Organisation located throughout the United Kingdom and Eire. We will be happy to deal with any problems.

## Hotpoint's Service Care

Whether you have just one or a number of Hotpoint appliances in your kitchen, Hotpoint has a range of Service Plans to give you complete peace of mind. They enable you to extend your one year labour guarantee so that you can have repairs completed **FREE** during the membership period.

## Service Cover

A single payment covers you for all repairs during the period of cover, which can be from 1 to 4 years. Service Cover also includes loss of food up to the value of £250 in refrigeration appliances. There is also an option of Service Cover with Maintenance at an additional cost. This includes an annual Electrical and Safety check and replacement of any parts as necessary.

## Kitchen Cover

An annual payment covers you for all repairs for all your Hotpoint appliances which are less than 10 years old. It also covers the cost of loss of food up to £250 in our refrigeration and freezer products. There is also the option of Kitchen Cover with Maintenance at an additional cost. Any additional Hotpoint appliances purchased after you have joined Hotpoint Kitchen Cover will automatically be included during the annual period of cover without further charge. Full details of these Service Plans are provided in the User Handbook supplied with your Hotpoint product or from any Hotpoint Service Office.

## Appliance Registration

To ensure that you have the opportunity to benefit from any of the above Service Schemes you should complete and return immediately the Appliance Registration Form supplied with your appliance. Full details and costs of our Service Schemes together with an application form will be sent to you at the end of the first year of the guarantee.

## Annual Safety/Maintenance Checks

Hotpoint strongly recommends that all its appliances are regularly checked for electrical and mechanical safety whether or not they are covered by a Service Plan. Worn door gaskets or hoses may cause a leak on an appliance which could become dangerous if neglected.

## Proof of Purchase

For future reference please attach your purchase receipt to this booklet and keep it in a safe place.

## Spares and Accessories

Spares and accessories can be ordered from your local Hotpoint Spares Centre (listed on the back page), using the order form enclosed.

**NOTE:** Our Engineer will use every effort to avoid damage to floor coverings and adjacent units when carrying out repairs/service work but in locations where the Engineer advises you that it will be impossible to move the appliance without risk of damage, he will only proceed with your approval that no liability is accepted.



## Changing the doors from right-hand to left-hand opening

### 1. Before you start!

- (a) **Make sure that a left-hand hung door would be able to open up to at least 90° (square) to the front of the fridge.**
- (b) Obtain a free door changeover kit from Hotpoint's service spares department (Tel: 01733 556520). Ask for part number 250 2016.  
Full fitting instructions are given with the kit.









# Hotpoint Service and Spares

**FOR SERVICE:** If you have a problem with your appliance ring your local Service Office.  
**FOR SPARES and ACCESSORIES:** To purchase spares and accessories send your Accessories Order Form to your Spares Centre. If the accessory or spare part you want is not on the form, contact your Spares Centre for prices and availability.  
 Please address all correspondence to Hotpoint Spares Centre or Hotpoint Service Office as applicable.

Service Offices and Spares Centres are open between 8.00am-5.00pm  
 Monday to Friday, except on Public Holidays. 8.30am-12.30pm on Saturdays.

■ Service Office and Spares Centre  
 ● Service Office only

## EAST

- **ESSEX:** Industrial Buildings, Beehive Lane, Chelmsford, CM2 9TE.  
 Post Codes RM & IG Tel: (0245) 492433  
 Remainder of Essex Tel: (0245) 269331
- **PETERBOROUGH:** Celta Road, PE2 9JB. Tel: (0733) 64741  
 For Spares Spares Administration Dept. Tel: (0733) 556520

## LONDON

- **HARROW:** Unit 10, Crystal Way, Harrow, Middlesex, HA1 2HP.  
 Tel: 081-863 3636  
 Tel: 081-863 4113  
 For Spares

## MIDLANDS

- **BIRMINGHAM:** Westgate, Aldridge, W Midlands, WS9 8UX.  
 Post Codes B Tel: (0922) 743374  
 All other Post Codes Tel: (0922) 743376  
 Tel: (0922) 743377  
 For Spares
- **NOTTINGHAM:** Ashling Street, NG2 3JB.  
 For Service Tel: (0602) 862431/864322 For Spares Tel: (0602) 860387
- **STOKE:** West Ave, Nelson Estate, Talke, ST7 1TN. Tel: (0782) 774511

## NORTH EAST

- **WASHINGTON:** 8 Bede House, Tower Road, Glover Est, District 11, NE37 2SH.  
 Tel: 091-417 3500/419 3535  
 Sandbeck Lane, LS22 4TW.  
 Tel: (0937) 581261/581444 For Spares Tel: (0937) 581221
- **WETHERBY:** For Service

## NORTH WEST

- **KENDAL:** Mumford House, 26 Highgate, LA9 4SX. Tel: (0539) 724483
- **MANCHESTER:** 44/46 Station Road, Heaton Mersey, Stockport, SK4 3QT.  
 Manchester North Tel: 061-432 0513  
 Manchester South Tel: 061-442 8677  
 Tel: 061-432 0255
- For Spares
- **NETHERTON:** 7 Bridle Way, Merseyside. Tel: 051-525 2342/524 2339

## SCOTLAND

- **ABERDEEN:** Holbeck House, 68 Carden Place, AB1 1UL. Tel: (0224) 642283
- **EDINBURGH:** 35 West Bowling Green Street, Leith, EH6 5NX. Tel: 031-554 1431
- **RENFREW:** West Lodge Road, Blythswood Estate, PA4 9EN.  
 Tel: 041-886 6241 For Spares Tel: 041-886 5611

## SOUTH

- **KENT:** Larkfield Trading Est, New Hythe Lane, Larkfield, ME20 6SW.  
 For Service Tel: (0622) 790707  
 For Spares Tel: (0622) 716631
- **SOUTHAMPTON:** Unit R, S Hampshire Ind Park, Salisbury Rd, Totton, SO40 3SA.  
 For Service Tel: (0703) 861981/667374 For Spares Tel: (0703) 867933
- **SUSSEX:** 1 Kingswood, North St, Hailsham, BN27 1DQ. Tel: (0323) 842733
- **PLYMOUTH:** 69 Mutley Plain, PL4 6JH. Tel: (0752) 262631

## WALES

- **NORTH:** Conwy Rd, Llandudno Junction, LL31 9RE. Tel: (0492) 573536
- **SOUTH:** 18 Western Ave, Bridgend Ind. Estate, Bridgend, CF31 3SL.  
 For Service Post Codes CF, SA & SY23-25 Tel: (0656) 664121  
 Post Codes BS, GL (not 55), HR, SY15-18, LD1-8, NP. Tel: (0656) 655554  
 Tel: (0656) 766111

## IRELAND

- **NORTHERN:** 256 Ormeau Road,  
 Belfast, BT7 2FZ.  
 Tel: (0232) 647111
- **EIRE:** 49 Airways Ind. Estate,  
 Dublin 17.  
 For Service Tel: Dublin 426088  
 For Spares Tel: Dublin 426836

**CHANNEL ISLANDS** — Service provided by Agents.  
 Normal Guarantees apply and all Service Schemes are available.

- JERSEY:** 19 Don Street, St. Helier.  
 Tel: (0534) 21625
- or Clos D'Ormes, Pontac,  
 St Clements. Tel: (0534) 54808

### GUERNSEY & SARK:

- Valpys Stores, Grande Rue, St Martins,  
 Guernsey. Tel: (0481) 38422
- or Barras Lane, Vale.  
 Tel: (0481) 51610

### ALDERNEY:

- 32 High Street,  
 Tel: (0481) 822686

**ISLE OF MAN** — Service provided by Agents.  
 Normal Guarantees apply and all Service Schemes are available

- from 5 Drumgold St., Douglas.  
 Tel: (0624) 673233
- or Tromode Works,  
 Cronkbourne Village, Douglas,  
 Tel: (0624) 676066
- or 17 Ridgeway Street, Douglas,  
 Tel: (0624) 25811/25848

**SHETLAND, ORKNEY & WESTERN ISLES** —  
 Service provided by Agents. Normal Guarantees apply, but  
 Service Schemes are NOT available.

- SHETLAND:** Fort Road, Lerwick.  
 Tel: (0595) 2557
- ORKNEYS:** Hatstone Ind. Estate, Kirkwall.  
 Tel: (0856) 5457
- WESTERN ISLES:** 27 Bayhead Street,  
 Stornoway, Isle of Lewis  
 Tel: (0851) 3387

**OTHER ISLANDS:** Local Hydro Electric Shops.

**EXCEPT ARRAN,  
 BUTE & SKYE** — Which are covered by Hotpoint.

In accordance with its policy of progressive product design,  
 the Company reserves the right to alter specifications.

Hotpoint Ltd, Peterborough, PE2 9JB, England

## Free Manuals Download Website

<http://myh66.com>

<http://usermanuals.us>

<http://www.somanuals.com>

<http://www.4manuals.cc>

<http://www.manual-lib.com>

<http://www.404manual.com>

<http://www.luxmanual.com>

<http://aubethermostatmanual.com>

Golf course search by state

<http://golfingnear.com>

Email search by domain

<http://emailbydomain.com>

Auto manuals search

<http://auto.somanuals.com>

TV manuals search

<http://tv.somanuals.com>