



kitchen think

Instructions for Installation and Use

**Fridge / Freezer
Model HMT40**

To the Installer

**Before installation fill in the product details on the back cover of this book.
The information can be found on the rating plate.**

To the User

**You must read the instructions prior to installing and using the appliance and
then retain them for future reference.**

CONTENTS

Product Safety	3
Installation	3
Electrical Connection	4
Get to Know your Appliance	5
The Display	6
Getting your Appliance ready for use	7
How to use The Display	8
How to use the Refrigerator Compartment	9
Storage Guide	10
How to use the Freezer Compartment	11
Ice Trays	12
Food Storage	13-14
Energy Saving Tips	15
Buzzer and Visual Warnings	15
Caring for your Appliance	16
Troubleshooting	17
After Sales Service	18
Hotpoint Guarantee	19
Key Contacts	Back Cover

Retention of this Instruction Book

This Instruction Book must be kept handy for reference as it contains important details on the safe and proper use of the appliance.

If you sell or pass the appliance to someone else, or move house and leave it behind, make sure this Book is also provided so the new owner can become familiar with the appliance and safety warnings.

If the Book is lost or damaged a copy may be obtained from:
GDA LTD., Morley Way, Peterborough, PE2 9JB



PRODUCT SAFETY

ATTENTION

Read your manual carefully since it contains instructions which will ensure safe installation, use and maintenance of your appliance.

Your Refrigerator is built to International safety standards (EN60) and has been awarded the European approval mark (IMQ) for compliance with UK electrical safety requirements. It also meets the EC standards on the prevention and elimination of radio interference (EC directive 87/308 - 02.06.89).

1. This appliance must not be installed outdoors - not even in an area protected by a roof. It is extremely dangerous to leave it exposed to rain or storms.
2. It must only be used by adults and exclusively to refrigerate and freeze foodstuffs, following the instructions for use contained in this manual.
3. Do not ever touch or handle the appliance with bare feet or with wet hands or feet.
4. It is highly recommended that you do not use extension cords or multiple socket adapters. If the refrigerator is installed between cabinets, make sure that the cord is not bent or dangerously pinched or compressed.
5. Never pull on the cord or the refrigerator to remove the plug from the wall socket - this is very dangerous.
6. Never touch the cooling components within the appliance, especially with wet hands because this could result in injury.
7. Never put ice cubes just removed from the freezer into your mouth because they could stick to your mouth and cause burns.

8. Never perform any cleaning or maintenance operations without first unplugging the appliance. Setting the appliance ON/OFF control to OFF is not enough to cut off all electrical contacts.

9. Before having your old refrigerator picked up for disposal, remove or make inoperable any locking devices to prevent children who might play in or around the appliance from being locked inside.

10. Before calling for service/assistance in the case of malfunction, consult the chapter entitled "TROUBLESHOOTING" to determine whether it is possible to eliminate the problem. Do not try to repair the problem by trying to access the internal components of the appliance.

11. If damaged, the power supply cord on this appliance must be replaced by our service centre because special tools are required for replacement.

12. Do not use electric appliances inside the compartment for food storage, if these are not those recommended by the manufacturer.

13. At the end of the functional life of your appliance – containing cyclopentane gas in the insulation foam and perhaps gas R600a (isobutane) in the refrigeration circuit – the latter should be made safe before being sent to the dump. For this operation, please contact your dealer or the Local Organisation in charge of waste disposal.

INSTALLATION

To ensure that the appliance operates properly and to reduce energy consumption, it is important that the appliance is installed correctly.

Ventilation

The compressor and condenser generate heat and, therefore, need to be ventilated properly. Avoid placing the appliance in direct sunlight, or next to an electric stove or similar appliance. Areas not adequately ventilated are not suitable for this appliance.

During installation, make sure not to cover or obstruct the grates that allow for proper ventilation of the appliance.

For proper ventilation of the appliance, you must leave:

- at least 10cm from top of appliance to underside of any cabinets above it.
- at least 5cm at the sides of the appliance to any adjacent cabinets/walls.

Away from Heat

Avoid positioning the appliance in a place where it is directly exposed to sunlight or near an oven, hob or the like.

Level

The appliance must be level. If the floor is not level, use the front adjustable feet to level the appliance.

Electrical Connection and Earthing

Before proceeding with the electrical connection, make sure that the voltage indicated on the rating plate, located within the fridge (bottom lefthand side), corresponds to the mains voltage in your home and that the socket is fitted with a standard earthing wire in accordance with safety standards for 46/90 systems. If the socket is not fitted with an earthing wire, the manufacturer will not be held liable for any damages and/or injuries arising out of the use of the appliance. Do not use multiple sockets or adapters.

Position the appliance in such a way that you can access the socket where it is plugged in.

Insufficient power?

The electrical socket must be able to handle the maximum power load of the appliance, which is indicated on the rating plate located within the freezer.

Before making the electrical connection ...

After the appliance has been delivered, place it in the vertical upright position and wait at least 3 hours before inserting the plug into the socket in order to ensure that it functions properly.

ELECTRICAL CONNECTION

Your appliance is supplied with a 13amp fused plug that can be plugged into a 13amp socket for immediate use. Before using the appliance please read the instructions below.

WARNING:
THIS APPLIANCE MUST BE EARTHED.

Replacing fuse covers:

When replacing a faulty fuse, a 13amp ASTA approved fuse to BS 1362 should always be used and the fuse cover re-fitted.

If the fuse cover is lost, the plug must not be used until a replacement is obtained.

Replacement fuse covers:

If a replacement fuse cover is fitted, it must be of the correct colour as indicated by the coloured marking or the colour that is embossed in words on the base of the plug.

Changing the plug:

Removing the plug

If your appliance has a non-rewireable moulded plug and you should wish to remove it to add a longer cable or to re-route the mains cable through partitions, units etc. please ensure that either:

- The plug is replaced by a fused 13amp re-wireable plug bearing the BSI mark of approval.

or

- The mains cable is wired directly into a 13amp cable outlet, controlled by a switch (in compliance with BS 5733) which is accessible without moving the appliance.

Disposing of the plug

Cut off and dispose of the supplied plug if it does not fit your socket. The cable should be cut as close as possible to the moulded plug. Remove the fuse.

WARNING:
To avoid a shock hazard do not insert the discarded plug into a socket anywhere else.

Fitting a new plug

IMPORTANT:

WIRES IN THE MAINS LEAD ARE COLOURED IN ACCORDANCE WITH THE FOLLOWING CODE...

Green and Yellow	-	Earth
Blue	-	Neutral
Brown	-	Live

As the colours of the wires in the mains lead may not correspond with the coloured markings identifying the terminals in your plug, proceed as follows:

- Connect Green and Yellow wire to terminal marked 'E' or $\frac{1}{\perp}$ or coloured Green and Yellow.
- Connect Brown wire to terminal marked 'L' or coloured red or brown.
- Connect Blue wire to terminal marked 'N' or coloured Black or Blue.

If a 13amp plug (BS 1363) is used it must be fitted with a 13amp fuse. A 15amp plug must be protected by a 15amp fuse, either in the plug or adaptor or at the distribution board.

If you are in any doubt about the electrical supply to your machine, consult a qualified electrician before use.

CE Marking certifies that this appliance conforms to the following EEC directives :

Low Voltage Equipment - 73/23/EEC & 93/68 EEC

Electromagnetic Compatibility 89/336/EEC, 92/31/EEC & 93/68/EEC

GET TO KNOW YOUR APPLIANCE

A Removable lidded shelf with egg tray and butter dish

B Removable miscellaneous shelf

Hinged bottle rack

D Bottle retainer

E Bottle shelf

F Ice trays

G Levelling feet

H Drain system, for drawing off defrost water from the freezer compartment

I Frozen Food storage compartments

J Compartment for freezing fresh food and storing frozen food

K Fruit and Vegetable Crispers

L 'Fresh box' compartment for meat and fish

M Removable/Adjustable Shelves

N Sliding box for cheese and cold cuts

O "A.I.R. System" (Advanced Integrated Refrigeration)

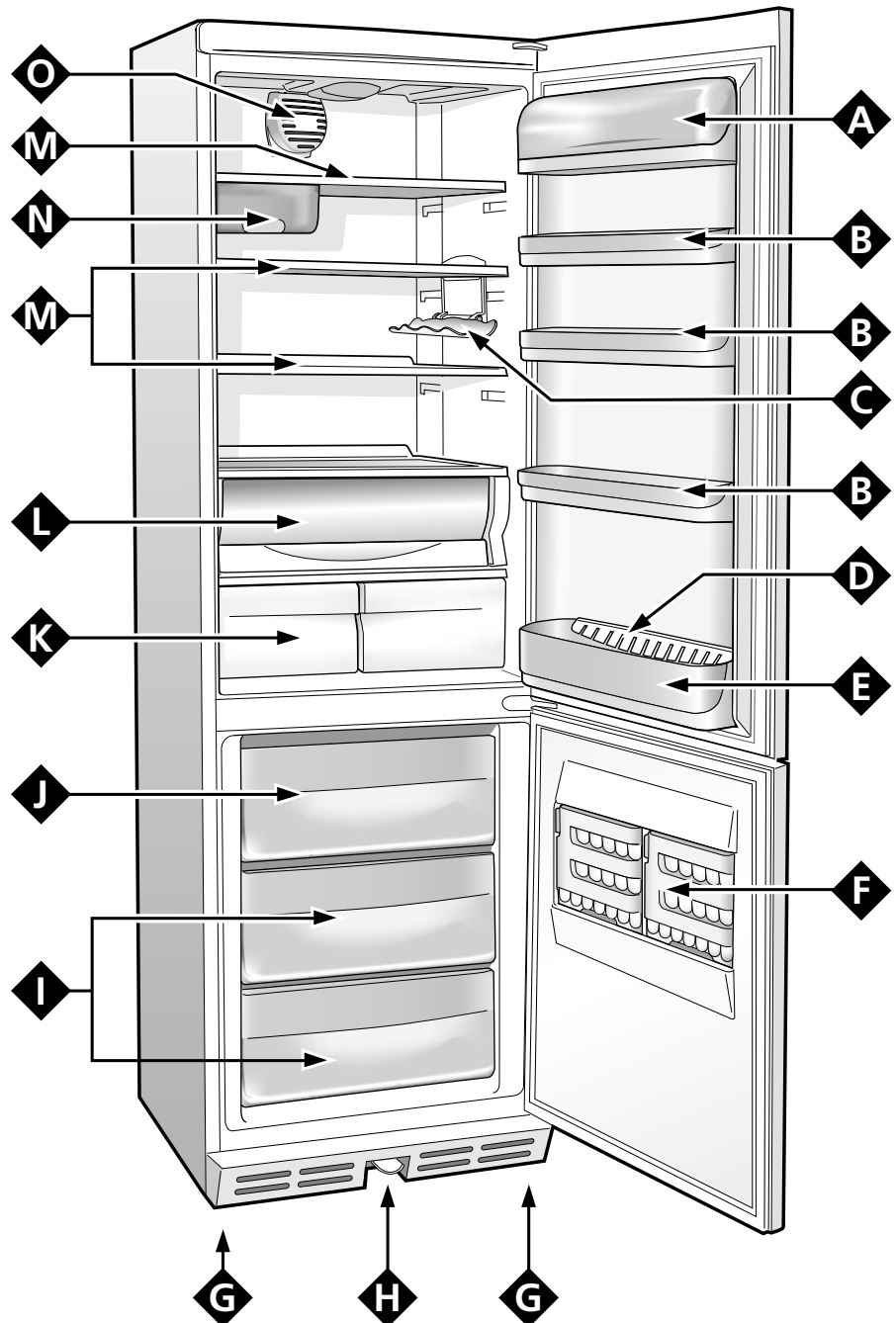

THE DISPLAY

A ON/OFF button



This button turns the entire appliance on or off (refrigerator and freezer compartments) (press it for more than two seconds).

B ON/OFF FRIDGE button



This button turns the refrigerator compartment on or off (press it for more than two seconds).

C RESET ALARM button



This button turns the alarm buzzer off, as well as cancelling scrolling text alarm messages from the display (simply press it).

D MODE button



This button allows you to 'navigate' the display to have access to the various settings and functions and then to make selections.

E ADJUST/SELECT + button



This button allows you to adjust/change the temperature, date, time and language or to select functions.

F ADJUST/SELECT - button



This button allows you to adjust/change the temperature, date, time and language or to deselect functions.

G Display: refrigerator compartment indication

Displays the temperature set in the fridge compartment (fixed figure), the temperature you are setting (flashing figure) and when the fridge compartment is turned off (word OFF displayed).



H Display: freezer compartment indication

Displays the temperature set in the freezer compartment (fixed figure), the temperature you are setting (flashing figure) and when the freezer compartment is turned off (word OFF displayed).

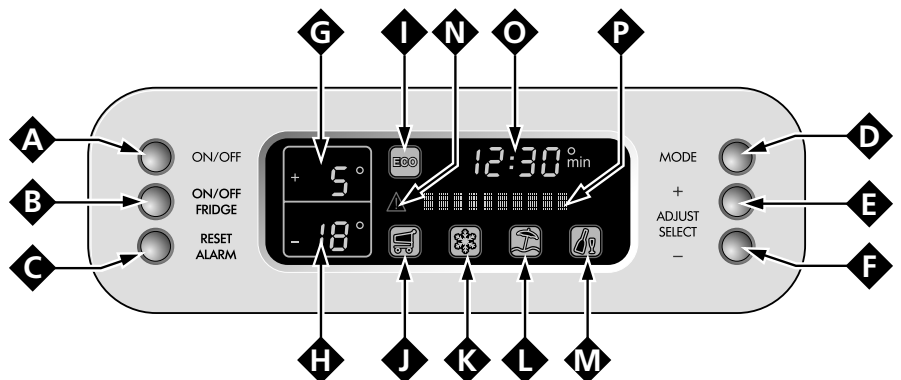

I Display: ECO function



Displays the status (ON or OFF) of the ECO function (optimal temperature at low consumption levels).

J Display: SUPER COOL function



Displays the status (ON or OFF) of the SUPER COOL function (rapid cooling of the refrigerator compartment).

K Display: SUPER FREEZE function



Displays the status (24hrs, 48hrs or OFF) of the SUPER FREEZE function (rapid freezing).

L Display: HOLIDAY function



Displays the status (ON or OFF) of the HOLIDAY function (optimal temperatures in the event of long-term absences without having to turn the appliance off).

M Display: ICE PARTY function



Displays the status (ON or OFF) of the ICE PARTY function (maximum speed in cooling a hot bottle and serving it at the table in the special bucket designed to maintain the temperature reached by the bottle).

N Display: alarm indicator



If enabled, it indicates the presence of a critical situation (door open, high temperature, etc...).

O Display: time indicator

Indicates the correct time and is used to set the date (month, day and year).

P Display: scrolling text

Used to set the language, it also provides general information as to the condition of the appliance and on how to interact with the display.

GETTING YOUR APPLIANCE READY FOR USE

NOTICE

After the appliance has been delivered, stand it in the upright position and wait approximately 3 hours before connecting it to the electrical outlet to guarantee that it operates properly.

Before placing foodstuffs in the refrigerator or freezer, clean the interior well with warm water and baking soda.

Motor protection delay

This model is provided with a motor protection control system. Therefore, if the compressor does not start immediately upon installation, do not worry as it will start automatically after approximately 8 minutes.

This is also what will happen every time the power supply is interrupted, both due to a power failure or should you switch it off yourself (to clean or defrost your freezer, for example).

After plugging the appliance into a suitable electricity socket, ensure the display is on with the "OFF" words in the indication spaces concerning the two compartments (fridge and freezer).

Freezer compartment

When the appliance is switched on (by pressing the **ON/OFF** button "A" for more than two seconds), the freezer compartment is automatically brought to the standard setting of - 18°C. We recommend you select the **SUPER FREEZE** function to speed up the cooling process of the compartment, when the latter has reached its optimal temperature, the function shall be automatically disabled and you may place your frozen food inside the freezer.

Refrigeration compartment

When the appliance is switched on, the refrigerator compartment turns on automatically, and it is brought to the standard setting of + 5°C. We recommend you select the **SUPER COOL** function to speed up the cooling process of the compartment, after a few hours, you may place food inside the refrigerator.

Language setting:

The first time you switch the appliance on you will be given a choice of five languages. The appliance is factory-set to English, if this is the language you require you need not do anything. However if you want Italian, French, Spanish or Portuguese you can change the language setting using the scrolling text on the display (**P**)

First press the **MODE (D)** button as many times as necessary for the scrolling text "IMPOSTAZIONE LINGUA [+/-] / CHOIX LANGUE [+/-] / SET LANGUAGE [+/-] / SELECCIONAR IDIOMA [+/-] / PROGRAMAÇÃO LÍNGUA [+/-]" to come up on the display.

Now you can choose the language using the **ADJUST/SELECT + (E)** (scrolls forward in the list of languages available that appear in the form of scrolling text) and/or **ADJUST/SELECT - (F)** (scrolls back in the list of languages available that appear in the form of scrolling text) buttons. Once the language you wish to select has appeared in the scrolling text, confirm the setting by pressing the **MODE (D)** button again: the language is now set.

NOTE: if you do not confirm your selection by pressing the **MODE (D)** button within ten seconds display shall go back to the language previously set and will show that no modification has been made.

NOTE: You can change the language setting at any time.

Setting the time and date:

The time and date settings are in rapid sequence and you cannot set the date without first setting the time.

Press the **MODE (D)** button as many times as necessary for the words "SET TIME [+/-]" to appear in the form of scrolling text.

Now you can set the exact time using the buttons **ADJUST/SELECT + (E)** (to go up one hour at a time) and/or **ADJUST/SELECT - (F)** (to go back one hour at a time). Once you have reached the time to set, confirm the setting by pressing the **MODE (D)** button once more, you should now set the minutes using the same procedure.

Once you have set the correct time, you should set the day and then the month and year, using the same procedure: buttons **ADJUST/SELECT + (E)** and **ADJUST/SELECT - (F)** for the exact digit and again the **MODE** button to confirm.

NOTE: if you do not confirm your selection by pressing the **MODE (D)** button within ten seconds of the last action performed, the display will show the setting previously made and indicate that no modification has been made.

How to use the display

Firstly, take all the advice that appears in the form of scrolling text on the display: it will be of use to you, especially when you make your first settings.

Temperature settings:

If the compartment concerned is switched off, the word **OFF** will appear on the appropriate space on the display (**G** for the refrigerator and **H** for the freezer). If the compartment is switched on, then the temperature set at that time will appear. To change it, press the **MODE (D)** button as many times as necessary for the figure corresponding to the temperature set to flash in the appropriate space. Now you can select the new temperature by pressing the **ADJUST/SELECT + (E)** (to increase the temperature displayed by one degree each time it is pressed) and/or **ADJUST/SELECT - (F)** (to decrease the temperature displayed by one degree each time it is pressed) buttons. Once you have reached the desired temperature, you should set it by pressing the **MODE (D)** button again to confirm the selection. Now the new temperature will stop flashing and will remain fixed in the appropriate space on the display to indicate that the new setting has been made.

NOTE: if you do not confirm your selection by pressing the **MODE (D)** button within ten seconds of the last action performed, the display will go back to show the previous temperature and indicate that no new temperature has been set.

The temperatures pre-set automatically are **+5°C** for the refrigerator compartment and **-18°C** for the freezer compartment and these are the standard temperatures for food storage.

The settable temperatures for the refrigerator compartment range from **+2°C** to **+8°C** and range from **-18°C** to **-26°C** for the freezer compartment.

- When the **ECO** function is selected, the possible settings are instead closer to the standard ones for food storage: from **+4°C** to **+6°C** for the refrigerator compartment and from **-18°C** to **-20°C** for the freezer compartment.

- When the **HOLIDAY** function is selected, the appliance automatically sets itself to the best setting for the situation: **+12°C** for the refrigerator compartment (if selected) and **-18°C** for the freezer compartment.

How to use the functions:



Function symbol in normal operating conditions (only green symbol lit)



Function selected (green symbol and red outline lit)



Function enabled (green symbol and blue background lit)

Press the **MODE (D)** button as many times as necessary for the red outline of the function you wish to select/deselect to light up and the words to appear on the display. This indicates that the function has been selected and is ready to be enabled or disabled. Now you can change the function using the **ADJUST/SELECT + (E)** (to enable it **ON**) and/or **ADJUST/SELECT - (F)** (to disable it **OFF**) buttons. To confirm the setting chosen for the function, press the **MODE (D)** button again. The red outline will come off to indicate the conclusion of operations on this function: if the function has been enabled, not only the green symbol lights up, but also the blue background, whereas if it has been disabled, the blue background will also come off and only the green symbol will stay lit.

NOTE: If you do not confirm your selection by pressing the **MODE (D)** button within ten seconds, the display will go back to show the function previously set and indicate that no new modification has been made.

SUPER COOL and **HOLIDAY** functions are linked to the refrigerator compartment and when it is switched off, these functions cannot be used.

- See **SUPER COOL** function on page 9.
- See **HOLIDAY** function in 'Temperature Settings' section (left).
- For **SUPER FREEZE** function see page 11.

How to use the refrigerator compartment...

The temperature inside the refrigerator is automatically adjusted according to the setting made on the display. We recommend, however, a medium position (+5°C).

The refrigerator compartment of your appliance is equipped with "A.I.R. System" which makes it possible to achieve optimal food storage while simplifying the use of the refrigerator thanks to the following features:

- Fast temperature reset: after the doors have been opened, the internal temperatures return to optimal levels faster, improving food storage.
- More uniform temperature distribution: this makes it possible to place any type of food on any shelf.
- Higher humidity level: this allows you to store food longer.

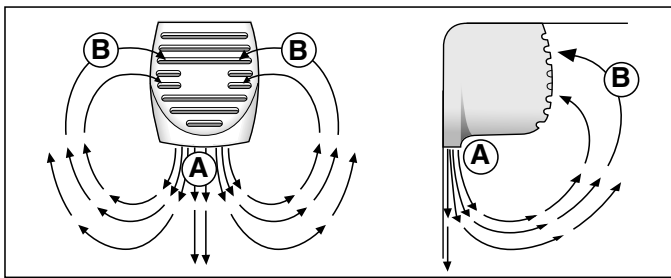

Hotter air is drawn in (B above). This air is cooled when it comes into contact with the refrigeration panel (A above).

Super Cool function

When the fridge compartment is filled up after a heavy shopping spree, use the **SUPER COOL (J)** function in order to reach optimum operating conditions quickly. Once the necessary time has elapsed, the function is disabled automatically.

Remember to follow our instructions on the storage life of foods: If not stored correctly, even the freshest food will deteriorate quite quickly.

Contrary to popular belief, cooked foods do not keep longer than fresh food.

The refrigerator compartment of your appliance is fitted with practical removable shelves (Fig. 1) whose height can be adjusted to allow storage of large containers. This allows you to place large items in the refrigerator.

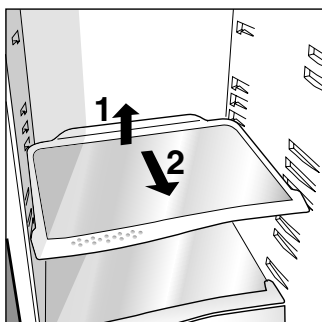

Fig. 1

Remember to cool hot food before storing otherwise the temperature inside the appliance will increase, causing the compressor to work harder and use more energy.

Do not store liquids in unsealed containers since this will increase the humidity and lead to the formation of frost in the refrigerator.

To use the cold cuts/cheese box, unhook it and remove it from the shelf. To optimise space according to your needs, the same can be moved laterally (Fig. 2).

The side bottle rack can be used either for storing a bottle (Fig. 3) or several cans (2-4) placed horizontally (Fig. 4). If not in use, the bottle/can rack can be tipped up and away to make more room inside the refrigerator.

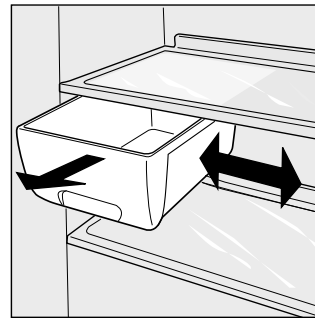

Fig. 2

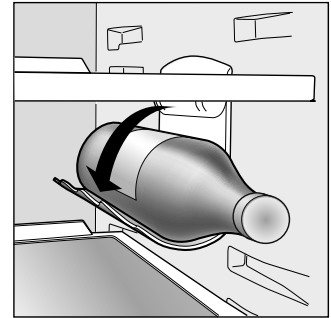

Fig. 3

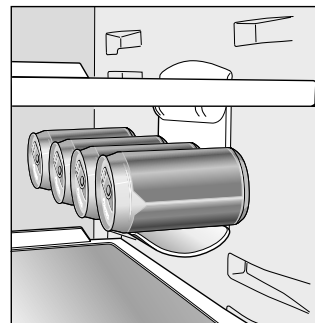

Fig. 4

Using the 'Fresh box' compartment for meat and fish

This compartment was designed to allow for longer preservation times for meat and fish (for as long as a week). This is possible, as this compartment has the coldest temperature of the entire fridge.

The clear protective door prevents any oxidation or blackening (typical of meat and fish when exposed to air).

The 'Fresh box' compartment can also be used to cool dishes that are normally eaten 'cold', such as melon and Parma ham, figs and ham, mozzarella and tomatoes.

STORAGE GUIDE

Storing Food in the Refrigerator Compartment

Food	Storage Time	Location in the Refrigerator
Wrapped meat and cleaned fish (use cling film or pack in plastic bags)	2 or 3 days	In the 'Fresh box' (which is the coldest area).
Fresh cheese	3 or 4 days	In the cold cuts/cheese box.
Eggs	1 month	In special egg rack on door.
Butter, margarine		On any shelf.
Cooked or precooked food (packed in air-tight containers and when cool store in refrigerator)	3 or 4 days	On any shelf.
Sausages, salami, sandwich meats in general, fresh pasta, custards, puddings, chocolates, cream pastries, bread, dry pastries, red tomatoes	3 or 4 days	On any shelf.
Bottled products, milk, drinks, yoghurt		On special door shelves.
Fruits and vegetables		In vegetable crisper.

What Not to Store in the Refrigerator

Garlic (transmits odour), onions and leeks.

Bananas (they will turn black).

Citrus fruits.

Potatoes and root vegetables (store in dark, dry places).

How to use the freezer compartment...

For the preparation of food to be frozen, please consult a specialized manual.

Food that has thawed, even partially, must not be re-frozen: you must cook it in order to consume it (within 24 hours) or to freeze it once again.

When freezing fresh foods, remember that they should not touch other previously frozen or deep frozen foods. Place the food that you wish to freeze in the top compartment "J" where the temperature will fall below -18°C, which is ideal for freezing food properly. Remember that proper conservation depends on the speed of freezing.

The maximum amount of food you can freeze per day is indicated on the data plate situated inside the refrigerator compartment.

The first time, or after the freezer has been inactive, you can only freeze food after having let the appliance function at maximum.

Food can be frozen using the **SUPER FREEZE 24hr** function (**Display 'K'**). After 24 hours, or once the optimal temperatures have been reached, the rapid freezing function switched off automatically.

When the appliance is already on, freezing can be done in two ways:

1. For small quantities, less than the maximum capacity indicated on the rating plate (situated on the lower left of the refrigeration compartment), enable the **SUPER FREEZE** function on the display in the "**24 hour**" mode and insert the food to be frozen. To enable the function, press the **MODE** button "**D**" until **SUPER FREEZE** appears on the scrolling text display. Press **ADJUST/SELECT + button (E)** until '24hrs' appears, then press the **MODE** button again. After 24 hours, or once the optimal temperatures have been reached, the rapid freezing function is disabled.

2. For large quantities of food to be frozen (up until the maximum load indicated on the rating plate situated on the lower left of the refrigeration compartment), enable the **SUPER FREEZE** function on the display in the "**48 hours**" mode. To enable the function, press the **MODE** button "**D**" until **SUPER FREEZE** appears on the scrolling text display. Press **ADJUST/SELECT + button (E)** until '48hrs' appears, then press the **MODE** button again. After 48 hours, or once the optimal temperatures have been reached, the rapid freezing function is disabled.

During the freezing process, avoid opening the door of the freezer.

In order to freeze and then thaw foods optimally, it is recommended that you divide food into small portions so that they freeze quickly and uniformly. The packages should be clearly marked with the content and the date they were frozen.

In order to obtain a larger amount of space in the freezer compartment, you can remove the central drawer, and place the food directly onto the evaporator plate. Make sure that, after having inserted the food, the door closes correctly.

Do not open the freezer door in the event of a power failure or malfunction. This precaution will slow the rise in temperature within the compartment. If the door is not opened, frozen and fast-frozen foods will remain in their current state for approximately 9-14 hours.

Do not place full bottles in the freezer: they could easily burst because all liquids increase in volume when they freeze.

To cool drinks down quickly.

Thanks to the special **ICE PARTY** function, you will no longer have to accept warm drinks just because you forgot to put the bottle in the fridge, just put the bottle in the bucket provided and put this into the freezer. Now select this function, the appliance itself will inform you, with a buzzer plus a message on the display, when it is time to remove the bottle from the freezer.

To turn off the buzzer and cancel the message from the display, just press the **REST ALARM** button "**C**".

You can carry the cool drink to the table easily in the bucket, thanks to special handles and keep it cool at length at the table.

WARNING: always keep the bucket provided for the bottle inside the freezer compartment (even when you don't have bottles to cool); only this way can the low temperature of the liquid be guaranteed in a short amount of time.

Remember when the **ICE PARTY** function has been enabled for optimal operation, the bucket with the bottle inside it, should be stored in the top part of 'J' in the freezer compartment.

Ice trays

This new concept for ice trays is exclusive to us. The fact that they are situated on the inner door of the freezer compartment ensures greater ergonomics and cleanliness, the ice no longer comes into contact with the food placed inside the freezer compartment; furthermore, the dripping of the water during filling is avoided (a lid to cover up the hole after filling with water is also provided).

To remove the ice trays from their housings, push the tray upwards and then pull it out (fig. 5). To put the tray back in place, insert the top part into the special housing and, once in a vertical position, just let it drop into place.

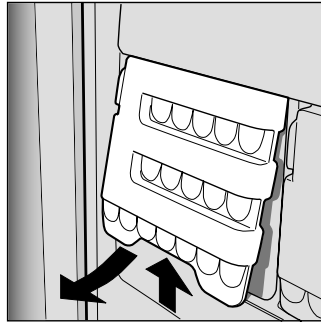

Fig. 5

Once the ice has formed, all you need to do is to knock the tray against a hard surface so that the ice cubes come away from their housing and come out of the same hole used to fill the tray with water. To make it easier for the ice cubes to come out, wet the outside of the tray.

WARNING: every time you fill up the ice tray with water, make sure that the same is completely empty and that there are no traces of ice left inside it.

The minimum time required for ice to form well is approximately 8 hours.

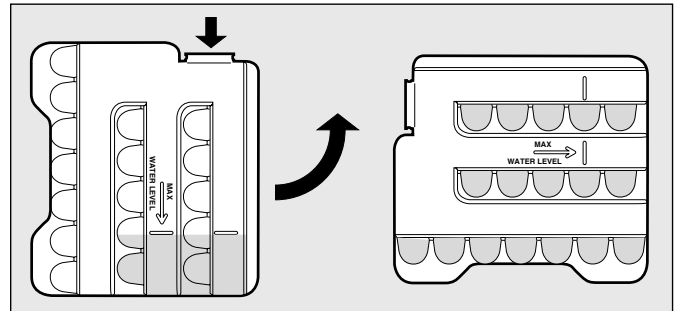

Fig. 6

Instructions for use (Fig. 6)

Fill up the tray with water via the special hole up to the level indicated (MAX WATER LEVEL), taking care not to overfill it, inserting more water than is necessary will lead to the formation of ice which could obstruct the exit of the ice cubes.

If you have used an excessive amount of water, you will have to wait until the ice has melted, empty out the tray and re-fill it with water.

Once you have filled the ice tray up with water through the hole indicated, turn it by 90°. Thanks to the connected compartments, the water fills up the special shapes, after which you can cover the hole up with the special cap and place the ice tray in the inner door of the freezer compartment.

FOOD STORAGE

Meat and Fish

Food	Wrapping	Tenderising (days)	Storage (months)	Thawing Time
Beef Roast	Tinfoil	2 / 3	9 / 10	Not required.
Lamb	Tinfoil	1 / 2	6	Not required.
Pork Roast	Tinfoil	1	6	Not required.
Veal Roast	Tinfoil	1	8	Not required.
Veal/Pork Chops	Each piece wrapped in cling film and then in tinfoil (4 to 6 slices)		6	Not required.
Veal/Lamb Cutlets	Each piece wrapped in cling film and then in tinfoil (4 to 6 slices)		6	Not required.
Minced Meat	In aluminium containers covered with cling film.	Freshly minced	2	Slowly in refrigerator.
Heart and Liver	Plastic Bags		3	Not required.
Sausages	Cling film or Tinfoil		2	As necessary.
Chicken and Turkey	Tinfoil	1 / 3	9	Very slowly in refrigerator.
Duck and Goose	Tinfoil	1 / 4	6	Very slowly in refrigerator.
Pheasant, Partridge and Wild Duck	Tinfoil	1 / 3	9	Very slowly in refrigerator.
Hare and Rabbit	Tinfoil	3 / 4	6	Very slowly in refrigerator.
Venison	Tinfoil or Cling Wrap	5 / 6	9	Very slowly in refrigerator.
Large Fish	Tinfoil or Cling Wrap		4 / 6	Very slowly in refrigerator.
Small Fish	Plastic Bags		2 / 3	Not required.
Crustaceans	Plastic Bags		3 / 6	Not required.
Shellfish	Store in salted water in aluminium containers or plastic containers.		3	Very slowly in refrigerator.
Boiled Fish	Tinfoil or Cling Wrap		12	In hot water.
Fried Fish	Plastic Bags		4 / 6	Directly in pan.

FOOD STORAGE

Fruits and Vegetables

Food	Preparation	Blanching Time	Wrapping	Storage (months)	Thawing Time
Apples and Pears	Peel and cut into slices.	2'	In Containers (cover with syrup)	12	In refrigerator very slowly.
Apricots, Peaches, Cherries and Plums	Peel and pit.	1' / 2'	In Containers (cover with syrup)	12	In refrigerator very slowly.
Strawberries Blackberries and Raspberries	Rinse and dry.		In Containers (cover with sugar)	10 / 12	In refrigerator very slowly.
Cooked Fruit	Cut, cook and strain.		In Containers (add 10% sugar)	12	In refrigerator very slowly.
Fruit Juice	Wash, cut and crush.		In Containers (sugar to taste)	10 / 12	In refrigerator very slowly.
Cauliflower	Remove leaves, cut head into small pieces and blanch in water and a little lemon juice.	2'	Plastic Bags	12	Not required.
Cabbage and Brussel Sprouts	Wash and cut into small pieces.	1' / 2'	Plastic Bags	10 / 12	At room temperature.
Peas	Shell and wash.	2'	Plastic Bags	12	Not required.
French Beans	Wash and slice if required.	2	Plastic Bags	10 / 12	Not required.
Carrots, Peppers and Turnips	Peel, wash and slice if necessary.	3' / 4'	Plastic Bags	12	Not required.
Mushrooms and Asparagus	Wash, peel and cut up.	3' / 4'	Plastic Bags or Containers	6	At room temperature.
Spinach	Wash and mince.	2'	Plastic Bags	12	At room temperature.
Vegetable for Soups	Wash and cut up in small pieces.	3'	Plastic Bags or Containers	6 / 7	Not required.
Various Foods	Preparation	Blanching Time	Wrapping	Storage (months)	Thawing time
Bread			Plastic Bags	4	At room temperature and in the oven.
Cakes			Plastic Bags	6	About 10 minutes at room temperature, cook at 100/200°C.
Cream			Plastic Containers	6	At room temperature or in refrigerator.
Butter			In original wrapping or tinfoil	6	In refrigerator.
Boiled Food or Vegetable Soup			Plastic or Glass Containers	3 / 6	At room temperature or in hot water.
Eggs			Freeze without shells in small containers	10	At room temperature or in refrigerator.

ENERGY SAVING TIPS

- Install the Appliance Correctly

This means that the appliance should be installed away from heat sources or direct sunlight in a well ventilated room.

THE ACTUAL ENERGY CONSUMPTION OF THE APPLIANCE DEPENDS ON THE WAY THE SAME IS USED AND ON ITS LOCATION.

The consumption tests were performed in 560mm deep column units, the most common installation setting for this appliance.

- Correct temperature settings

Set the compartment temperature to one of the middle settings. Very cold temperature settings will not only consume a great deal of energy but will neither improve nor lengthen the storage life of the food. Excessively cold temperatures may ruin vegetables and cheese.

- Do not Overfill

Remember that proper storage of food requires good air circulation. Overfilling your appliance will hamper proper air circulation and overwork the compressor.

- Keep the Doors Closed

Open your doors only when necessary, remember that every time you open the door most of the cold air will be lost. To bring the temperature back to the proper level, the motor must run for a considerable amount of time, consuming a substantial amount of energy.

- Check the Door Seals

Keep the seals clean and make sure that they fit tightly against the door. This alone will ensure that no cold air escapes.

- No Hot Foods

A container of hot food in the refrigerator will increase the temperature significantly, allow food to cool to room temperature before storing.

- Check you appliance for build up of ice

Check the thickness of the frost on the walls of the freezer and immediately defrost it if the layer becomes too thick. (see CARING FOR YOUR APPLIANCE).

BUZZERS AND VISUAL WARNINGS

Door open alarm

Should the refrigerator door be left open for more than two minutes, the light inside the compartment will begin to flash; after a few seconds, even if the door was shut in the meantime, an alarm buzzer is sounded. To silence this buzzer, just shut the door (or open and shut the door) - or press the **RESET ALARM** button "C".

Abnormal freezer heating alarm

1. To signal excessive heating on the part of the freezer (e.g. momentary power failure), a buzzer will sound and a scrolling text message comes up on the display to signal the excessive heating of the compartment. To prevent food from refreezing, the freezer will try to maintain a temperature of 0°C, thus allowing you to use up the food within 24 hours or to cook it and then refreeze it. You can turn the buzzer off simply by pressing the **RESET ALARM** button "C".

To return to normal operation and cancel the message from the display, press the **RESET ALARM** button "C" again.

2. If the temperature inside the freezer continues to rise to excessively high values, the buzzer will sound yet again and another scrolling text message will come up on the display to signal the dangerous state of overheating. We recommend you check the conditions of the food, as it may be necessary to throw it away. In all cases, food should not be refrozen unless you cook it first. To prevent food from refreezing, the freezer will try to maintain a temperature of 0°C. The buzzer can be turned off by simply pressing the **RESET ALARM** button "C". To return to normal operation and cancel the message from the display, press the **RESET ALARM** button "C" again.

CARING FOR YOUR APPLIANCE

Before proceeding with any cleaning or defrosting operations, disconnect the appliance from the electricity mains (by setting the appliance to OFF keep button "A" pressed down for more than 2 seconds, until OFF in both the refrigerator and freezer compartments and then unplugging the appliance). Should you fail to do this, the appliance may go into alarm mode. **WARNING: this alarm is not a sign of any anomaly.** To return to normal operating mode, keep ON/OFF button "A" pressed down for more than 2 seconds to turn the appliance off and then turn it back on and set the required temperatures.

Defrosting

WARNING: do not damage the refrigeration circuit. Do not use mechanical devices or other tools to speed up the defrosting process, unless they have been recommended by the manufacturer.

How to Defrost the Refrigerator

This appliance defrosts automatically, and the water is ducted to the back of the appliance by a special outlet (fig. 7) where the heat produced by the compressor makes it evaporate. The only thing you must do is to periodically check and clean the hole of the drain, which is located behind the fruit and vegetable crispers, so that the water drains properly.

How to defrost the freezer compartment

- Remove the frost from time to time with the aid of the special scraper provided (do not use knives or metal objects).
- If the frost is more than 5 mm thick, then you must defrost the freezer completely. Proceed as follows: one day before defrosting enable the **SUPER FREEZE** function in the 24-hour mode; it helps give the food a healthy extra "cold shock".
- After 24 hours, the freezing function is automatically disabled but you can disable it yourself.
- Turn the appliance off by pressing the appliance ON/OFF button "A" for more than 2 seconds.

WARNING: this operation switches off the whole appliance (including the fridge compartment).

- Wrap all frozen foods in newspaper and place them either in another refrigerator or in a cool place. Leave the door open, so as to allow all the frost to melt completely, helping it along with containers filled with lukewarm water.

The unit is provided with a system which allows the defrost water to be collected in a container placed beneath the unit (see fig. 8).

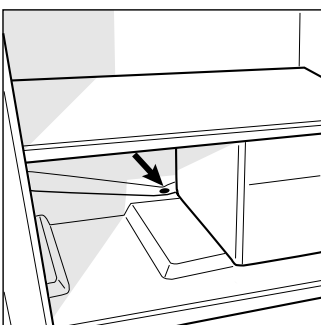

Fig. 7

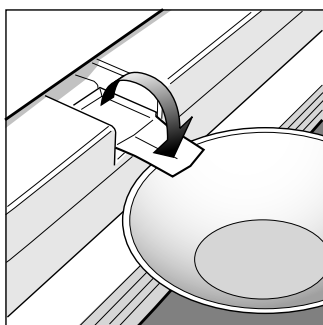

Fig. 8

Clean and dry thoroughly before restarting the appliance. Remember that the motor will not start immediately, but after approximately 8 minutes.

HOLIDAY FUNCTION. Mould and bad odours forming inside your unused fridge when you go on holiday need no longer be a problem: just enable the Holiday function (from the display). This way, with limited energy consumption, the temperature of the refrigerator compartment is kept at around 12°C and the freezer is operated at its minimum setting, which is essential for food preservation.



Cleaning and maintenance of the parts

Before cleaning, switch off - keep the ON/OFF button "A" pressed down for more than 2 seconds, until 'OFF' is displayed in both the fridge and freezer compartments, then unplug the appliance.

- Your appliance is manufactured with hygienic, odourless materials. To preserve these characteristics, always use sealed containers to store foods, in order to prevent spills which could stain and cause unpleasant, difficult to remove odours.
- Use a water and bicarbonate solution to clean the appliance. Clean the interior and exterior with a sponge soaked in warm water and a sodium bicarbonate solution, which is, among other things, a good disinfectant. If you do not have any in the house, you can use a neutral soap.
- DO NOT use abrasive detergents, bleach or detergents containing ammonia. NEVER use solvent based products.
- All removable parts should be taken out and soaked in warm soapy water or detergent. Rinse and dry them thoroughly before putting them back in the appliance.
- Occasionally use a vacuum to carefully remove dust which may collect on the back panel.
- When the appliance is not used for a long time, remember to clean the interior and dry thoroughly, leave the doors open to prevent the formation of mould and unpleasant odors.
- Replacing the light bulb. The bulb for lighting the interior of the refrigerator is located at the back of the thermostat box. When replacing the lamp, unplug the appliance from the electrical socket, unscrew the burned out lamp and replace it with another with a wattage no higher than 15W. For access to lamp "A", remove the centre screw "B" at the back of the lamp cover, as indicated in fig. 9.

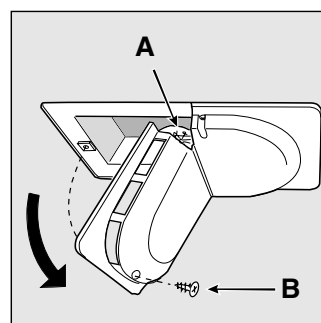

Fig. 9

TROUBLESHOOTING

The display is completely switched off

Check that:

- The mains switch in your home is on.
- There has not been a power cut.
- The plug is properly inserted in the socket and is switched on.
- The socket is working; try another appliance in the socket to check.
- The fuse in the plug is ok - if not replace it, (see ELECTRICAL CONNECTION).

The motor does not start

Check that:

- 8 minutes have passed since you switched the appliance on?

This model is provided with a motor protection control system which means that it will only start approximately 8 minutes after being switched on.

The refrigerator and the freezer do not cool properly.

Check that:

- The doors close well and that the seals are not damaged
- The doors have not been left open too long.
- The temperature settings are correct.
- The refrigerator or freezer is not overfilled.

The food inside the refrigerator is too cold

Check that:

- the temperature is on the best setting.
- The food is not in contact with the back wall - which is the coldest part.

The motor runs constantly

Check that:

- the **SUPER COOL** and/or **SUPER FREEZE** and/or **ICE PARTY** functions are enabled.
- the temperature settings are correct.
- the doors have not been open continuously.
- The room temperature is too high.

The appliance makes too much noise.

The gas refrigerant produces a slight noise even when the compressor is not running (this is not a defect).

Check that:

- The appliance is level.
- The appliance was installed between cabinets or objects that vibrate and make noise.

There is water on the bottom of the refrigerator.

Check that:

- The defrost drain is clear from any blockage (fig.7).

If after all the checks, the appliance still does not operate or the problem persists, call Hotpoint Service (see KEY CONTACTS, back page) and inform them of: the type of problem, the abbreviation of the model name (Mod.) and the relative numbers (S/N) written on the rating plate located at the bottom left of the refrigerator compartment.

Never call on unauthorized technicians and always refuse spare parts which are not originals.



After Sales Service

"No company is better positioned to offer an after sales service on a Hotpoint appliance than us - the manufacturer"

As part of our commitment to you, all Hotpoint appliances have the added benefit of a fully inclusive parts and labour guarantee for the first 12 months. In addition to this you also have the advantage of **free replacement parts for the first 5 years** when fitted by a Hotpoint engineer. When the 12 months parts and labour guarantee expires we offer the following after sales service options:

Repair Service and Information Help Desk

UK: 08709 066066

www.theservicecentre.co.uk

Republic of Ireland: 1850 302 200

Note: Our operators will require the Model number and the Serial number of your appliance

Available 364 days a year with a fast, effective and value for money service. We have the largest white goods repair service in the UK with over 1200 of our own fully trained engineers. All repairs include a parts and labour guarantee for 12 months from the date of the repair.

If you require any information or have any questions about your appliance, our operators are on hand with help and advice.

All this ensures that you will receive the best available after sales service possible.

Extended Warranties

UK: 08709 088 088

www.theservicecentre.co.uk

Republic of Ireland: 1850 502 200

Whether you have just one or a number of Hotpoint appliances in your kitchen, we offer two service cover plans to give you total peace of mind.

- Repair Protection Plan - FREE service repairs for a single Hotpoint appliance during the period of cover.
- Kitchen Cover - FREE service repairs for all your Hotpoint appliances less than 8 years old.

Genuine Parts and Accessories UK: 08709 077 077

www.theservicecentre.co.uk

Republic of Ireland: (01) 842 6836

A wide range of genuine parts and accessories are available from our hotline or through our web site.

Genuine parts and accessories, extended warranties and service repairs are all available on our web-site at:



www.theservicecentre.co.uk



Guarantee

"Satisfaction guaranteed or your money back"

We give you a unique 'satisfaction guaranteed' promise - **valid for 90 days** - after you have purchased your Hotpoint appliance. If there is a technical problem simply call Hotpoint Repair service or visit our web-site at www.theservicecentre.co.uk and where necessary, we will arrange for an engineer to call. If the technical problem is not resolved under this guarantee, **we will replace your machine or, if you prefer, give you your money back.**

All Hotpoint appliances carry a fully inclusive 12 month parts and labour guarantee as well as free replacement parts for the first 5 years (except microwaves, selected integrated appliances and cooker hoods, which have a one year guarantee) provided that they are fitted by a Hotpoint engineer.

Guarantee terms and conditions

Your guarantee is only applicable in the United Kingdom or Republic of Ireland and is subject to the following provisions that your appliance:

- Has been installed and used correctly in accordance with this instruction booklet.
- Has been used solely for domestic purposes and is located on domestic premises (ie. not for commercial or trade use).
- Has been properly connected to a suitable electrical supply voltage as stated on the appliance rating plate.
- Has not been subject to misuse, accident, modified or repaired by anyone other than one of our own service engineers.



For pre purchase information on any other Hotpoint product call: 08701 50 60 70
or visit: www.hotpoint.co.uk



Recycling & Disposal Information

As part of Hotpoint's continued commitment to helping the environment, Hotpoint reserves the right to use quality recycled components to keep down customer costs and minimise material wastage. Please dispose of packaging and old appliances carefully.

To minimise risk of injury to children, remove the door, plug and cut mains cable off flush with the appliance. Dispose of these parts separately to ensure that the appliance can no longer be plugged into a mains socket, and the door cannot be locked shut.



Key Contacts

After Sales Service

Over 1200 trained specialists, directly employed by us, ensure that you can have complete confidence in both the appliances and services we offer.



Repair Service and Information Desk

UK: 08709 066 066

(Open 8 to 8 Mon - Fri, 8 to 6 Sat, 10 to 4 Sun & Bank Holidays)

www.theservicecentre.co.uk

Republic of Ireland: 1850 302 200

Note: Our operators will require the following information:

Model number:

Serial number:

Extended Warranties

UK: 08709 088 088

(Open 8 to 8 Mon - Sun)

www.theservicecentre.co.uk

Republic of Ireland: 1850 502 200

Genuine Parts and Accessories

UK: 08709 077 077

(Open 8-30 to 5-30 Mon - Fri & 9 to 12 Sat)

www.theservicecentre.co.uk

Republic of Ireland: (01) 842 6836

Free Manuals Download Website

<http://myh66.com>

<http://usermanuals.us>

<http://www.somanuals.com>

<http://www.4manuals.cc>

<http://www.manual-lib.com>

<http://www.404manual.com>

<http://www.luxmanual.com>

<http://aubethermostatmanual.com>

Golf course search by state

<http://golfingnear.com>

Email search by domain

<http://emailbydomain.com>

Auto manuals search

<http://auto.somanuals.com>

TV manuals search

<http://tv.somanuals.com>