

HP NetServer 10/100TX PCI LAN Adapter Installation Guide



HP Part Number 5969-8430

Printed in April 2000

Notice

The information contained in this document is subject to change without notice.

Hewlett-Packard makes no warranty of any kind with regard to this material, including, but not limited to, the implied warranties of merchantability and fitness for a particular purpose. Hewlett-Packard shall not be liable for errors contained herein or for incidental or consequential damages in connection with the furnishing, performance, or use of this material.

Hewlett-Packard assumes no responsibility for the use or reliability of its software on equipment that is not furnished by Hewlett-Packard.

This document contains proprietary information that is protected by copyright. All rights are reserved. No part of this document may be photocopied, reproduced, or translated to another language without the prior written consent of Hewlett-Packard Company.

Windows 95[®], Windows for Workgroups[®], Windows 2000[®] and Windows NT[®] are registered trademarks of Microsoft in the U.S. and other countries. Novell NetWare[®] is a registered trademark of Novell, Incorporated. SCO[®] UNIX[®] is a registered trademark of The Santa Cruz Operation, Incorporated. Unix[®] is a registered trademark in the United States and other countries, licensed exclusively through X/Open Limited. Banyan[®] and VINES[®] are registered trademarks of Banyan Systems Incorporated. IBM and OS/2 are registered trademarks of the International Business Machines Corporation. Cisco and Fast EtherChannel[®] are registered trademarks of Cisco Systems, Incorporated or its affiliates in the U.S. and certain other countries. AppleTalk is owned by the University of Melbourne and is subject to copyright under the laws of Australia and, through international treaties, other countries.

Hewlett-Packard Company
Network Server Division
Technical Communications / MS 45SLE
10955 Tantau Avenue
Cupertino, CA 95014 USA

© Copyright 2000, Hewlett-Packard Company.

Audience Assumptions

The guide is for the person who installs, administers, and troubleshoots LAN servers. Hewlett-Packard Company assumes you are qualified in the servicing of HP NetServer equipment and trained in recognizing hazards in products with hazardous energy levels.

Contents

1 HP NetServer 10/100TX PCI LAN Adapter for PCI Systems	1
Included Parts	2
2 Where to Go for More Information	3
Readme Files	3
Service and Support	3
3 Installing the Adapter in the NetServer	5
4 Connecting the Network Cable	7
Connect the Wake on LAN Power Cable	8
Using Wake on LAN	9
Make a Setup Floppy Disk	10
5 Configuring the Adapter and Installing Drivers	11
Novell NetWare 5.0 Only	11
Novell NetWare 4.1x or 4.2 Only	12
Windows 2000	13
Install Network Drivers from Disk	13
Windows NT Automatic Configuration	14
Adding an Adapter while Installing Windows NT	15
Windows NT Version 4.0 Only	15
Windows NT Version 3.51 Only	15
Windows NT Troubleshooting	16
UNIX, Banyan VINES, and Other Operating Systems	17
HPSet: An Overview	17
Priority Packet: An Overview	18
Prioritizing Network Traffic	18
IEEE 802.1p Tagging	19
High Priority Queue	20
6 Installing Multiple Adapters	21
NetWare Users	21
Windows NT 3.51 Users	21
7 Selecting Duplex Mode (Optional)	23
Manually Configuring for Full Duplex	24

Setting Full Duplex in Windows NT/2000	24
Setting Full Duplex in NetWare Servers.....	24
Setting Full Duplex in Other Operating Systems	25
Join a Virtual LAN.....	25
General Configuration Notes	26
Adding a VLAN in Windows NT 4.0	26
Adding a VLAN in Windows 2000	27
8 Choosing Adapter Teaming Options.....	29
General Configuration Notes	29
Setting up Adapter Fault Tolerance	30
Setting up Adapter Fault Tolerance in Windows NT 4.0.....	30
Configuring Properties	31
Deleting a Team	31
Setting up Adapter Fault Tolerance in NetWare.....	31
Deleting a Team	33
Setting up Adaptive Load Balancing.....	33
Setting up ALB in Windows NT 4.0.....	34
Deleting a Team	34
Setting up ALB in NetWare.....	34
Setting Up Cisco Fast EtherChannel.....	35
Setting up FEC in Windows NT 4.0.....	35
Setting up FEC in NetWare	36
Teaming Options Supported by OS and Protocol.....	36
9 Troubleshooting and FAQs.....	37
If the Adapter Can't Connect to the Network	37
Make sure the cable is installed properly.	37
Check the LED lights on the adapter.	37
Responder Testing on the Network (Optional)	37
Make sure you're using the correct drivers.	39
Make sure the switch port and the adapter have the same duplex setting.	39
Testing the Adapter (Diagnostics).....	39
Frequently Asked Questions (FAQs).....	39
10 Technical Information.....	41
PCI Installation Tips	41
Removing an Existing Adapter in Windows 2000.....	42

Removing an Existing Adapter in Windows NT	42
Fast Ethernet Wiring.....	43
Power Management.....	43
11 Specifications	45
12 Warranty and Support	47
Hardware Warranty	47
HP Repair and Telephone Support	47
13 Regulatory Information.....	49
Notice for United States (Federal Communications Commission)	49
Notice for Canada (Industry Canada).....	50
Notice for Japan	50
Notice for Taiwan	51
Declaration of Conformity (US and EU)	52
A Quick Install Guide in Chinese	53
Index	55

1 HP NetServer 10/100TX PCI LAN Adapter for PCI Systems

- Compatible with IEEE 802.3u 100Base-T standard for 100 Mbps
- Compatible with IEEE 802.3i 10Base-T and Ethernet standards for 10 Mbps
- Supports PCI slots (Peripheral Component Interconnect) version 2.2 standard
- Fully PCI Plug-and-Play compatible; no switches or jumpers
- A single RJ-45 twisted-pair connector with automatic detection of LAN type 10-Mbps or 100-Mbps when the cabling is attached
- Same driver set for both 10-Mbps and 100-Mbps operation
- Adapter Fault Tolerance (AFT) provides redundant links to the network
- Fast EtherChannel (FEC) increases transmission and reception throughput
- Adaptive Load Balancing (ALB) increases transmission throughput
- Virtual LAN (VLAN) Support (IEEE 802.1Q) increases network performance and improves network security
- Priority Packet (IEEE 802.1p) support for critical applications
- TCP Checksum Offload
- Driver support for major network operating systems

- Bus master data transfer mode and optimized drivers ensure high performance and low CPU utilization
- Full-duplex capability
- LEDs for easy monitoring of LAN adapter status
- Configuration, diagnostic, and information utility named Setup
- Windows-based configuration and diagnostic utility named HPSet
- Capable of supporting Desktop Management Interface (DMI) and Simple Network Management Protocol (SNMP) network management
- Client drivers for desktop LAN solutions are not supported (such as NetWare, Windows 95, Windows NT, Windows for Workgroups, and others)

Included Parts

- One LAN adapter card (product number HP D5013B)
- One *HP NetServer 10/100TX PCI LAN Adapter Drivers* CD
- Software License Agreement
- The *HP NetServer 10/100TX PCI LAN Adapter Installation Guide* (this manual)

2 Where to Go for More Information

Readme Files

For detailed information about the adapter, view the "ReadMe" files on the *HP NetServer 10/100TX PCI LAN Adapter Drivers CD*.

Topics include:

- Installing adapter drivers
- Latest news and general adapter information
- Hardware specifications and cabling information
- Adapter installation and special configurations
- Running diagnostics
- Setting up Adapter Teaming Options

Service and Support

Hewlett-Packard's automated electronic services provide product information, troubleshooting tips and solutions, and the latest drivers to download.

These 24-hour-a-day online services include:

- HP FIRST Fax Retrieval Service
- HP BBS (Bulletin Board)
- FTP services on the Internet and CompuServe
- World Wide Web Site:
<http://www.hp.com/netserver/support>

3 Installing the Adapter in the NetServer

NOTE If you are replacing an existing adapter with the HP NetServer 10/100 adapter in Windows NT, see the section *Removing an Existing Adapter in Windows NT* in Chapter 10, "Technical Information," later in this guide.

1. Shut down Windows (if it's running) by clicking the Start button, and then clicking Shut Down.
2. Turn off the server and unplug the power cord. Then remove its cover.

<p>WARNING Turn off and unplug power to the server before removing its cover. Failure to do so could shock you and may damage the adapter or server.</p>

3. Remove the cover bracket from a PCI busmaster adapter slot by unscrewing the screw that secures it. Most computers have busmaster-enabled slots. If you have configuration problems, see your computer's documentation to determine if the PCI slots are busmaster-enabled.
4. If you want to enable the Wake On LAN feature, see the *Connect the Wake On LAN Power Cable* section in Chapter 4, "Connecting the Network Cable," later in this guide before completing the rest of these steps.
5. Insert the HP NetServer 10/100 adapter into a PCI slot and push it into the slot until it's firmly seated. Then secure the adapter bracket with the screw you removed in step 3.
6. Replace the server cover and plug in the power cord.

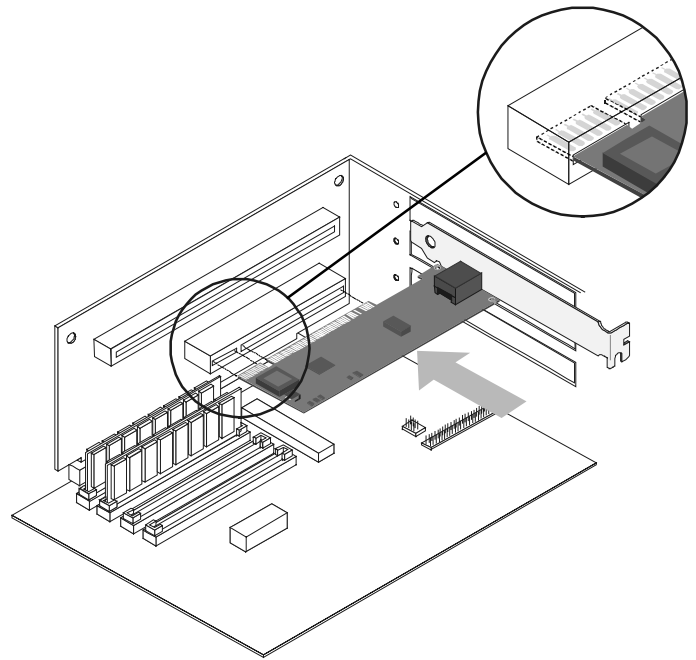

Figure 3-1. Installing the Adapter in the HP NetServer

4 Connecting the Network Cable

1. Connect a Twisted Pair Ethernet (TPE) network cable to the adapter as shown below.
 - For 100BASE-TX, your network cable must be Category 5, twisted- pair wiring. If you want to run the adapter at 100 Mbps, it must be connected to a 100BASE-TX hub or switch (not a 100BASE-T4 hub).
 - For 10BASE-T, use Category 3, 4, or 5 twisted-pair wiring. If you want to use this adapter in a residential environment, you must use a Category 5 cable.



PC-9564

NOTE

Use a Category 5 TPE cable and a RJ-45 connector for this adapter. Do not use Category 3 wiring at 100 Mbps. At 100 Mbps, connect to a TX hub, not a T4 hub. For full duplex, see the *Duplex Mode* section later in this guide. For more information on 100BASE-TX wiring requirements and limitations, see the *Fast Ethernet Wiring* in *PCI Installation Tips* section later in this guide.

2. To configure the adapter, continue with the procedures specific to your operating system outlined later in this guide.

Connect the Wake on LAN Power Cable

For the Wake on LAN (WOL) feature to work correctly, the adapter must be connected to a continuous power source. This allows the HP NetServer 10/100 adapter to “listen to” the network even when the computer is turned off. To install the WOL power cable, carefully follow the procedure below.

WARNING

Turn off and unplug power to the computer before installing the WOL cable. The WOL connector on your motherboard is live when the computer is plugged in to a power outlet. Failure to do so could damage the adapter or computer. Likewise, always unplug the computer prior to removing an adapter from the computer.

1. Make sure your computer is unplugged from the power outlet.
2. Locate the 3-pin WOL connector on the HP NetServer 10/100 adapter. Attach one end of the WOL cable to the adapter as shown in Figure 4-1.

NOTE

The connector is notched so as to prevent incorrect attachment.

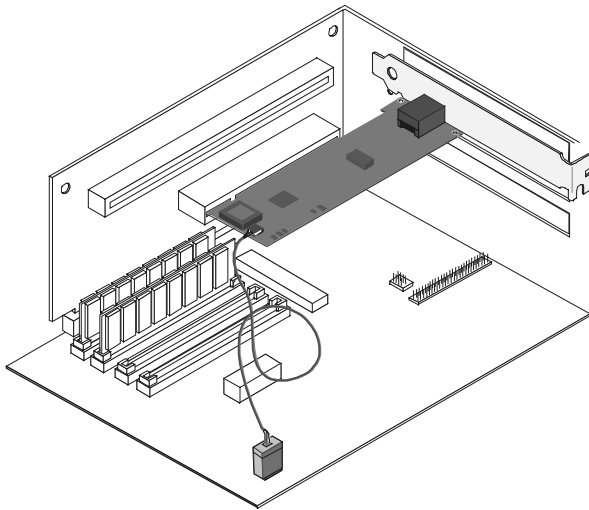

Figure 4-1. Connecting the Wake On LAN Cable

3. Locate the WOL connector on your motherboard. The location varies, depending on the vendor and model of motherboard. The WOL connector is usually located near other power connectors, such as the LED connectors.
4. Connect the other end of the WOL cable to the connector on the motherboard as shown in Figure 4-1.
5. Some computers may require you to change a setting in your computer's BIOS or Setup program to enable the WOL feature. Check your computer owner's manual or contact your dealer for more information.
6. Replace the computer cover and plug in the power cord.

Using Wake on LAN

The Wake on LAN feature operates according to a published specification. In simple terms, the specification allows designers to build network adapters that are capable of “listening” to network activity even when the computer is turned off.

WOL adapters have a special low-power standby mode that is active when the rest of the computer is without power. The adapter will respond to a special “wake-up” packet sent by

another computer or network device. Typically, this wake-up packet causes the adapter to signal the computer to power up and run a pre-defined program.

See the *Troubleshooting and FAQs* section later in this guide for general troubleshooting and a listing of common problems and solutions for Wake on LAN operability.

Make a Setup Floppy Disk

If you need to use a floppy disk to install the adapter drivers, use the MAKEDISK.BAT utility located in the ROOT directory on the *HP NetServer 10/100TX PCI LAN Adapter Drivers CD*.

```
MAKEDISK [operating system] [destination]
```

where [operating system] is the OS for which you are creating the diskette and [destination] is the drive letter and path (such as A:).

The possible [operating system] options are:

W2K = Microsoft Windows 2000

NT = Microsoft Windows NT

NW = Novell NetWare servers and clients

OS2 = IBM OS/2

UTIL = DOS Diagnostics and information

5 Configuring the Adapter and Installing Drivers

Novell NetWare 5.0 Only

Use the NetWare Install program to install the HP NetServer 10/100 adapter driver in Novell NetWare 5.0. For Novell NetWare 4.1x, see the *Novell NetWare 4.1x or 4.2 Only* section following this section. For Novell NetWare 3.11, 3.12 and 3.2, see the ReadMe files. The following procedure is a condensed description of the installation process:

1. From the NetWare console, type NWCONFIG and press **Enter**.
2. From the Configuration Options screen, choose **Driver Options** and press **Enter**.
3. Choose **Configure network drivers** and press **Enter**. If any drivers are already loaded, a list of them appears.
4. Choose **Select** an additional driver and press **Enter**. A list of drivers appears.
5. Insert the *HP NetServer 10/100TX PCI LAN Adapter Drivers* CD into the CD-ROM drive and press the **Insert** key to install an unlisted driver.
6. To specify the correct path to your media (if necessary), press **F3**. Press **Enter** to search the floppy or CD-ROM drive. To install from the CD, type the CD Volume Name: \NetWare Server Name. For example, HPTX_PCI_A+:\NWSERVER.
7. Select the appropriate HP PCI LAN Adapter and press **Enter**.
8. Respond to the Copy and Save prompts.
9. Use the arrow keys to select additional protocol types, **F3** to manually set IPX Frame types, or choose the defaults.
10. Enter the slot number. (You can find the slot number by switching to the Console and manually loading the driver. A list of available slot numbers is displayed. Then abort

(press **Esc**) the manual install and return to the NWConfig screen.)

11. Select **Save parameters** and load driver to continue.
12. For each additional adapter you want to install, respond to the prompt and then repeat steps 7-11.
13. To complete the driver installation process, press the **Esc** key until you arrive back at the Installation Options screen.
14. To return to the console prompt, choose **Exit**.

NOTE If the adapter cannot transmit or receive following the installation, you may need to modify the frame type in the `AUTOEXEC.NCF` file.

Novell NetWare 4.1x or 4.2 Only

Use the NetWare install program to install the HP NetServer 10/100 adapter driver in Novell NetWare 4.1x. For Novell NetWare 3.11, 3.12 and 3.2, see the ReadMe files. The following procedure is a condensed description of the installation process:

NOTE Prior to installing, either load DOS or NetWare drivers from your computer's CD-ROM drive or create a floppy disk from the *HP NetServer 10/100TX PCI LAN Adapter Drivers* CD using the `MAKEDISK.BAT` utility. See the *Making a Setup Floppy Disk* section earlier in this guide.

1. From the NetWare console, type `LOAD INSTALL` and press **Enter**.
2. From the Installation Options screen, choose **Driver options** and press **Enter**.
3. Choose **Configure network drivers** and press **Enter**. If any drivers are already loaded, a list of them appears.
4. Choose **Select an additional driver** and press **Enter**. A

list of drivers appears.

5. Insert the *HP NetServer 10/100TX PCI LAN Adapter Drivers* CD into the CD-ROM drive and choose Install an unlisted driver by clicking **Insert**.
6. If necessary, specify the correct path to your media by pressing **F3**. Press **Enter** to search the floppy or CD-ROM drive.
7. The driver name is displayed: HP NetServer 10/100 adapter. Press **Enter** to select it.
8. The next screens ask for frame and protocol types. Use the arrow keys to select specific items or choose the defaults. Select **Save parameters** and load driver to continue.
9. For each additional adapter you want to install, press Esc, and then repeat steps 7-8.
10. To complete the driver installation process, press the **Esc** key until you arrive back at the Installation Options screen.
11. To return to the console prompt, choose **Exit**.

NOTE	If the adapter cannot transmit or receive following the installation, you may need to modify the frame type in the AUTOEXEC.NCF file.
-------------	---

Windows 2000

Install Network Drivers from Disk

After you put the HP NetServer 10/100 adapter in the computer, connect the network cable, plug in the power cord and start the computer. Windows automatically installs a driver for the adapter from its own library of drivers. However, you should still install the driver that is included on the *HP NetServer 10/100TX PCI LAN Adapter Drivers* CD to ensure you have the complete set of features described in this guide. You can install this driver manually using the following instructions:

1. Insert the *HP NetServer 10/100TX PCI LAN Adapter Drivers* CD in the CD-ROM drive. (If the HP Product

Setup Autorun screen appears, you may close it.)

2. From the Control Panel, double-click the System icon, select the Hardware tab, and click the Device Manager button.
3. Select "Network Adapters" and right-click on the HP NetServer 10/100 adapter listing to display its menu. Then click the **Properties** menu option.
4. From the Properties dialog box, click the **Driver** tab and click the **Update Driver** button. The Upgrade Device Driver Wizard appears. Click **Next**.
5. At the prompt "What do you want the wizard to do?" select the "Search for a suitable driver for my device" radio button and click **Next**.
6. Select the CD-ROM drives check box and click **Next**.
7. Select the "Install one of the other drivers" check box and click **Next**.
8. Select the driver on the *HP NetServer 10/100TX PCI LAN Adapter Drivers* CD and click **Next**.
9. Restart your computer.

After restarting your computer, connect to your network by double-clicking **My Network Places** icon on the desktop.

Windows NT Automatic Configuration

PCI computers automatically detect and configure PCI-compliant adapters while starting the computer. The adapter IRQ level and I/O address are automatically set by the BIOS each time you start your server.

Start your server to automatically configure the adapter. Configuration is complete when Windows NT starts or when the DOS prompt appears.

If your server displays an error while booting, it may require additional steps to configure. See the *PCI Installation Tips* section later in this guide for more information.

Adding an Adapter while Installing Windows NT

The HP driver that ships with Windows NT 4.0 is an older driver that does not support this adapter.

Therefore if you want to install the HP NetServer 10/100 adapter while installing Windows NT, you need to install the adapter after the installation of Windows NT is complete or install the adapter software from a floppy installation disk created from the *HP NetServer 10/100TX PCI LAN Adapter Drivers* CD (using the `MAKEDISK.BAT` file on the root of the CD).

Windows NT Version 4.0 Only

After putting the adapter in the server, connecting the cable, and starting Windows NT, you need to install the correct drivers.

1. Double-click the **Network** icon in Control Panel.
2. Click the **Adapters** tab.
3. Click **Add**. You'll see a list of adapters.
4. Don't select an adapter from this list. Instead, insert the *HP NetServer 10/100TX PCI LAN Adapter Drivers* CD into the appropriate drive and click **Have Disk**.
5. Specify the appropriate drive in the dialog box and click **OK**. Then follow the prompts to complete installation. When the adapter is added you'll see a new adapter listed in the Network adapters list.
6. Click **Close** to finish.
7. Restart Windows NT when prompted.

Windows NT Version 3.51 Only

After putting the adapter in the server, connecting the cable, and starting Windows NT; you need to install the correct drivers.

1. Double-click the **Network** icon in Control Panel.
2. Click **Add Adapter**.

3. When the list of adapters appears, scroll to the end of the list and select **<Other> Requires disk from manufacturer**, then click **Continue**.
4. Insert the *HP NetServer 10/100TX PCI LAN Adapter Drivers* CD in the appropriate drive, specify that drive, then click **OK**.
5. Select the **HP NetServer** adapter, and then click **OK**. Drivers and utilities are installed.
6. The TCP/IP Configuration dialog box appears. Enter the appropriate information and click **OK**. Remove the *HP NetServer 10/100TX PCI LAN Adapter Drivers* CD.
7. When prompted, restart Windows NT.

NOTE

For troubleshooting information, see the next section, *Windows NT Troubleshooting*.

Windows NT Troubleshooting

If Windows NT reports an error or you can't connect to the network, try the suggestions here first, then turn to the *Troubleshooting and FAQs* section later in this guide, if necessary.

1. Make sure that you use the drivers for this adapter. Drivers are located on the *HP NetServer 10/100TX PCI LAN Adapter Drivers* CD.
2. In your computer's BIOS settings, make sure "Plug and Play OS" is set to NO.
3. Make sure the driver is loaded and the protocols are bound. Check the Settings in the Control Panel's Network/Bindings dialog box.
4. Check the Windows NT Event Viewer for error messages.
5. If you are attaching to a NetWare network, check your frame type and verify that NetWare client or server software has been installed.
6. Test the adapter with the HPSet advanced configuration utility that was installed on your system when you installed the HP NetServer 10/100 adapter. To start HPSet,

double-click the **HPSet** icon in the Windows Control Panel. To run diagnostics, select the adapter and click the **Diagnostics** tab, then click **Run Tests**. For additional information, click **Help** in the HPSet window.

7. Check with your LAN administrator — you may need to install supplemental networking software.

UNIX, Banyan VINES, and Other Operating Systems

Refer to the online documents. On a DOS computer, view the appropriate ReadMe file for information on installing your network driver.

To view the ReadMe files go to the \INFO folder and use a text editor such as Notepad.

HPSet: An Overview

When you install the HP NetServer 10/100 adapter Windows drivers, an advanced configuration utility called HPSet is also installed. Users running Windows 2000 or NT can easily test hardware and set standard and advanced adapter features with HPSet. HPSet runs when you select an adapter and click the **Properties** button in the Network Control Panel.

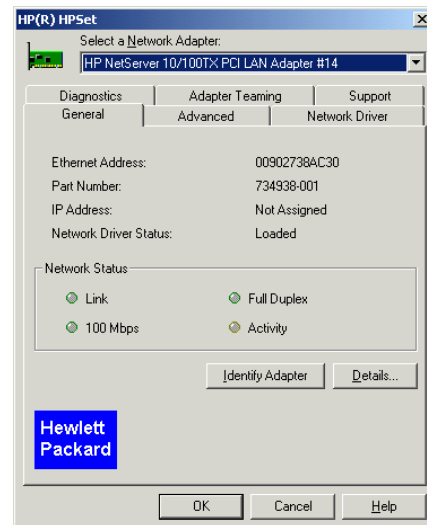

Figure 5-1. HPSet for Windows NT

Priority Packet: An Overview

Priority Packet is a traffic-prioritization utility that enables you to set up priority filters to process high priority traffic before normal traffic. Using Priority Packet, you can give priority to critical applications or users.

Priority Packet is available on the *HP NetServer 10/100TX PCI LAN Adapter Drivers* CD in the \Priority Packet directory.

Prioritizing Network Traffic

Priority Packet lets you set up priority filters to send information from critical nodes or applications with an indicated priority. By prioritizing traffic at the host or entry point of the network, network devices can base forwarding decisions on priority information defined in the packet.

Priority Packet prioritizes traffic based on priority filters — parameters you assign to be applied to outgoing (transmit) packets. Using the Priority Filter Wizard, you can set up pre-defined or custom priority filters based on a node (MAC) address, Ethernet type, or by various properties of the protocol

and port. Priority Packet provides two different methods for prioritizing traffic: IEEE 802.1p tagging and High Priority Queue.

IEEE 802.1p Tagging

IEEE 802.1p is a new IEEE standard for tagging, or adding additional bytes of information to, packets with different priority levels. Packets are tagged with four additional bytes, which increase the packet size and indicate a priority level. When these packets are sent out on the network, the higher-priority packets are transferred first. Priority packet tagging (also known as Traffic Class Expediting) allows the adapter to work with other elements of the network (switches, routers) to deliver priority packets first. 802.1p tagging enables you to assign specific priority levels from 0 (low) to 7 (high).

Using the IEEE 802.1p standard for packet tagging, you can assign values to packets based on their priority. This method requires a network infrastructure that supports packet tagging. The routing devices receiving and transferring these packets on your network must support 802.1p for tagging to be effective.

After you set up the priority filter in Priority Packet, you must launch HPSet and select 802.1p/802.1Q Tagging on the Advanced tab.

CAUTION

IEEE 802.1p tagging increases the size of the packets it tags. Some hubs and switches won't recognize the larger packets and will drop them. Check your hub or switch documentation to see if it supports 802.1p. (You can configure the switch to strip the tags from the packets and send it on to the next destination as normal traffic.) If these devices don't support 802.1p or you're not sure, use High Priority Queue (HPQ) to prioritize network traffic.

The requirements for effectively using IEEE 802.1p tagging are:

- The other devices receiving and routing 802.1p tagged packets must support 802.1p.
- The adapters on these devices must support 802.1p (adapters using the 82558 or later Ethernet controller). All HP NetServer 10/100 adapters support 802.1p.
- The adapter(s) cannot be assigned to an adapter team.
- If you're setting up VLANs and packet tagging on the same adapter, you must select the 802.1p/802.1Q Tagging and the Enable option on the HPSet Advanced tab.

High Priority Queue

If your network infrastructure devices don't support IEEE 802.1p or you're not sure, you can still define priority filters and send packets as high priority. While High Priority Queue (HPQ) doesn't provide the precise priority levels of 802.1p tagging, it does assign traffic as either high or low priority, and sends high priority packets first. Therefore, if there are multiple applications on a system sending packets, the packets from the application with a priority filter are sent out first. HPQ doesn't change network routing, or add any information to the packets.

To assign HPQ, you can specify it using Priority Packet when you create or assign a priority filter.

To effectively use HPQ tagging, the adapter(s) cannot be assigned to an adapter team.

6 Installing Multiple Adapters

The adapter's 12-digit, hexadecimal Ethernet address is printed on a sticker placed on the adapter. The Ethernet address is sometimes called the node address or the MAC address. Note that the PCI slot number may not correspond with the physical connector in your NetServer.

NetWare Users

The server drivers use the PCI slot number to identify each installed adapter. You can correlate the PCI slot number to the adapter by using the Ethernet address that is printed on a label on the adapter. Run Setup to view the Ethernet address and slot number for each installed adapter. For more information, see the ReadMe files.

Windows NT 3.51 Users

Repeat the configuration procedure for each adapter you want to install.

7 Selecting Duplex Mode (Optional)

Duplexing is a performance option that lets you choose how the adapter sends and receives data packets over the network. The adapter can operate at full duplex only when connected to a full duplex 10BASE-T or 100BASE-TX switch, or to another full duplex adapter.

The possible settings for duplexing are:

- **Auto** (requires a full duplex adapter or switch with auto-negotiation capability). The adapter negotiates with the switch to send and receive packets at the highest rate. This is the default setting. If the switch does not provide auto-negotiation, the adapter runs at half duplex.
- **Full duplex** (requires a full duplex switch or adapter). The adapter can send and receive packets at the same time. This mode can increase adapter performance capability. If the full duplex switch provides auto-negotiation, the adapter runs at full duplex. If the full duplex switch does not provide auto-negotiation, you need to set the adapter duplex mode manually (see the following sections), because it defaults to half duplex.
- **Half duplex**. The adapter performs one operation at a time; it either sends or receives.

NOTE	If an adapter is running at 100 Mbps and half-duplex, your potential bandwidth is higher than if you run it at 10 Mbps and full duplex.
-------------	---

Manually Configuring for Full Duplex

If your switch supports auto-negotiation with the NWay standard, duplex configuration is automatic and no action is required on your part. However, many currently installed switches do not support auto-negotiation. Check with your network system administrator to verify whether your switch supports this feature. Most installations require manual configuration to change to full duplex.

Configuration is specific to the driver you're loading for your network operating system (NOS).

To set up the duplex mode, refer to the section below that corresponds to your operating system.

CAUTION

Adapter performance may suffer or your adapter may not operate if your switch doesn't support full duplex and you configure the adapter to full duplex. The switch settings must always agree with the adapter. Also, make sure to always set the speed when you configure duplex.

Setting Full Duplex in Windows NT/2000

While running Windows:

1. Double-click the **HPSet** icon from the Control Panel.
2. Click the **Advanced** Tab.
3. Select **Duplex**.
4. In the Duplex Mode list box, click **Full Duplex**.
5. Click **OK**.
6. Restart Windows.

Setting Full Duplex in NetWare Servers

For each adapter in `AUTOEXEC.NCF`, edit the `LOAD` command and add the following options (you must include the equal sign for servers):

FORCEDUPLEX=2

SPEED=100 (or 10 if 10BASE-T)

For more information, see the ReadMe file for NetWare servers.

Setting Full Duplex in Other Operating Systems

See the OTHER.TXT ReadMe file in the \OTHER directory on the *HP NetServer 10/100TX PCI LAN Adapter Drivers* CD. Open the file with any text editor.

Join a Virtual LAN

A Virtual LAN (VLAN) is a logical grouping of network devices put together as a LAN regardless of their physical grouping or collision domains. VLANs let a user see and access only specified network segments. This increases network performance and improves network security.

VLANs offer the ability to group users and stations together into logical workgroups. This can simplify network administration when connecting clients to servers that are geographically dispersed across the building, campus, or enterprise network.

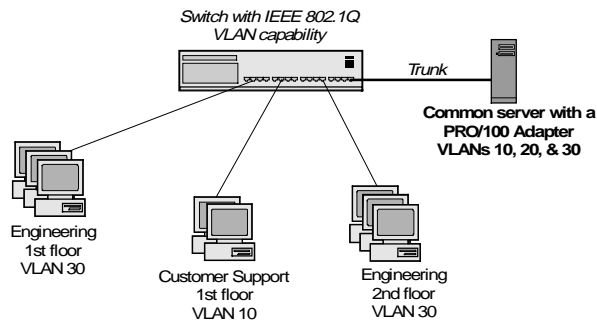

Figure 7-1. Virtual LAN Configuration

Typically, VLANs consist of co-workers within the same department but in different locations, groups of users running the same network protocol, or a cross-functional team working

on a joint project. Joining workers with VLANs forms logical working groups.

VLANs are normally only configurable at the switch. However, the HP NetServer 10/100 adapter software permits you to configure a NetWare server with up to 64 VLANs, and 55 VLANs for Windows NT 4.0.

To set up VLAN membership, your adapter must be attached to a switch with VLAN capability.

For more information on VLANs in NetWare, see the NWTEAM.TXT file on the *HP NetServer 10/100TX PCI LAN Adapter Drivers CD*.

For more information on VLANs in Windows NT, continue to the next section.

General Configuration Notes

1. Windows NT versions prior to 4.0 don't support VLANs.
2. VLANs require Windows 2000 or Windows NT 4.0 with Service Pack 4.0 (or later).
3. In Windows NT and Windows 2000, VLANs cannot be implemented on adapters that have been configured for teaming options.
4. 802.1p/802.1q is required for VLANs to function. You can enable this feature through the Advanced tab in HPSet.
5. HP NetServer 10/100 adapters only support VLANs configured in compliance with the IEEE 802.1q specification. No support for ISL (Inter-Switch Link) VLANs is intended.

Adding a VLAN in Windows NT 4.0

1. Create a VLAN on the switch. Use the parameters you assign there to join the VLAN from the server. See your switch documentation for more information.
2. Double-click the **Network** icon in Control Panel.
3. On the Adapters tab, select the adapter you want to be on a VLAN and click **Properties**.
4. In HPSet, click **Join VLAN**. Note that VLANs cannot be

- assigned to adapters that are already in an Adapter Teaming option.
5. Enter the VLAN ID and VLAN Name. The VLAN ID must match the VLAN ID on the switch. Valid ID range is from 0-4095. The VLAN Name is for informational purposes only and doesn't have to match the name on the switch.
 6. Click **Join VLAN**. Repeat steps 3-5 for each VLAN you want the server to join. The VLANs you add are listed on the Adapters tab.
 7. Click **Close** and restart the computer.

Adding a VLAN in Windows 2000

IMPORTANT You must use HPSet to add or remove a VLAN in Windows 2000. Do not use the Network and Dial-up Connections dialog box to enable or disable VLANs. Otherwise, the VLAN driver may not be correctly enabled or disabled.

1. Create a VLAN on the switch. Use the parameters you assign there to join the VLAN from the server. See your switch documentation for more information.
2. In HPSet, click the **Virtual LAN** tab. Note that VLANs cannot be assigned to adapters that are already in an Adapter Team.
3. Under the Virtual LAN tab, click the **ADD** button.
4. If this is the first VLAN you're creating, you may see the following message: "In order for VLANs to function, you must be connected to a switch which supports IEEE VLANs (802.1Q). Also, 802.1p/802.1Q Tagging must be enabled on this adapter. Would you like to enable 802.1p/802.1Q Tagging on this adapter?" If this message appears, click **Yes** to continue. HPSet will automatically enable the 802.1p/802.1Q feature on the Advanced tab.
5. Enter the VLAN ID and VLAN Name and click **OK**.
6. The VLAN ID must match the VLAN ID on the switch. Valid ID range is from 1-4094. The VLAN Name is for

informational purposes only and doesn't have to match the name on the switch.

7. Repeat steps 3 and 5 for each VLAN you want the server to join. 802.1p/802.1q is enabled for all VLANs after it is enabled for the first VLAN. The VLANs you add are listed on the Adapters tab.
8. At the Virtual LAN tab, click **OK** and restart the computer.

8 Choosing Adapter Teaming Options

The HP NetServer 10/100 adapter provides several options for increasing throughput and fault tolerance when running Windows 2000, Windows NT 4.0 or NetWare 4.2 or newer:

NOTE Use of the teaming features requires HP Server adapters.

Adapter Fault Tolerance (AFT) — provides automatic redundancy for your adapter. If the primary adapter fails, the secondary takes over. Adapter Fault Tolerance supports two to eight adapters per team.

Adaptive Load Balancing (ALB) — allows balancing the transmission data flow among two to eight adapters. Also includes the AFT option. Works with any 100BASE-TX switch.

Cisco Fast EtherChannel (FEC) — creates a team of two, four, six or eight adapters to increase transmission and reception throughput. Also includes AFT option. Requires a switch with FEC capability. (See your switch documentation for the number of ports you can aggregate in a team.)

To set up an option, go to the appropriate section in the pages that follow.

General Configuration Notes

- Windows NT versions prior to 4.0 don't support adapter teaming options.
- Adapter Teaming options require Windows NT 4.0 with Service Pack 4 or higher.

Setting up Adapter Fault Tolerance

NOTE Use this procedure for setting up AFT only. If setting up ALB or FEC, use the procedures in the next sections. The AFT feature runs automatically when you enable ALB or FEC.

Adapter Fault Tolerance (AFT) provides the safety of an additional backup link between the server and buffered repeater or switch. In the case of a buffered repeater or switch port, cable, or adapter failure, you can maintain uninterrupted network performance through an adapter team.

AFT is implemented with a primary adapter and one or more backups, or secondary adapters. During normal operation, the backup adapters are in standby. If the link to the primary adapter fails, the link to the secondary adapter takes over.

Setting up Adapter Fault Tolerance in Windows NT 4.0

1. See software requirements for AFT in the previous section, *General Configuration Notes*.
2. Double-click the **Network** icon in Control Panel.
3. On the Adapters tab, select a HP NetServer 10/100 adapter that will be in the team and click **Properties**. (Don't use an adapter that is on a VLAN.)
4. In the HPSet window, click the **Adapter Teaming** tab.
5. Click the **Add Adapter to a Team** button.
6. The Teaming Wizard starts. Follow the wizard steps for assigning adapters to a team. AFT supports up to eight adapters per team, in any combination. Note that you can specify a Preferred Primary adapter, which in most cases will be your highest bandwidth adapter. See the HPSet Help for more information.
7. Click **OK**, then click **Close** to finish. When prompted, restart your computer.

Configuring Properties

The default AFT properties are suitable for most applications. To adjust them, follow this procedure.

1. Run HPSet.
2. On the adapter list, select the desired AFT team.
3. Click the **Advanced Settings** tab.
4. Adjust parameters as required. Click **Help** for more information.

Deleting a Team

1. Double-click the **Network** icon in Control Panel.
2. On the Adapters tab, select the AFT team to delete.
3. Click **Remove**. A confirmation dialog box appears. Click **Yes**.
4. Click **Close**. Restart Windows NT when prompted.

NOTE When IPX is used, the frame type for each adapter in the team reverts to Auto when a team is deleted. You may need to set it to the specific frame type to connect to your network.

Setting up Adapter Fault Tolerance in NetWare

1. Copy the following lines from the EXAMPLES.TXT file (on the *HP NetServer 10/100TX PCI LAN Adapter Drivers* CD), paste them into the appropriate files, and modify them. These commands assume the HPANS.LAN and CHPTX.LAN files are in the system directory (SYS:SYSTEM) of your server. (Files must be copied from the *HP NetServer 10/100TX PCI LAN Adapter Drivers* CD to your server's hard drive).

NOTE The HPANS.LAN driver requires more resources (memory) than a traditional LAN driver. To accommodate this, the minimum and maximum packet receive buffers need to be increased. The exact numbers depend on the complexity of the team; however, the following settings (which are to be added to the STARTUP.NCF file) should be sufficient for most single team systems.

Copy these lines into the STARTUP.NCF file

```
SET MINIMUM PACKET RECEIVE
BUFFERS=500

SET MAXIMUM PACKET RECEIVE
BUFFERS=2000
```

Copy these lines into the AUTOEXEC.NCF file

;- Load the base driver for each adapter where x is the primary adapter's slot number and y is the secondary adapter's slot number.

```
load CHPTX slot=x name=primary
load CHPTX slot=y name=secondary
```

Do not bind protocols to the base (CHPTX) driver.

```
;- Load HPANS to form the basis of a team
load HPANS

;- Bind HPANS to each physical adapter
bind HPANS CHPTX primary
bind HPANS CHPTX secondary

;- Use HPANS to commit the team where z is
the teaming mode of your choice: Specify
AFT for Adapter Fault Tolerance, ALB for
Adaptive Load Balancing, or FEC for Fast
Ether Channel.

load HPANS commit mode=z
```



```
;- Bind the protocol to HPANS instead of to  
the base driver
```

```
bind ipx HPANS net=1
```

Variable Definitions:

slot= the slot number your HP NetServer 10/100 adapter is installed in, such as 1. If you don't know the number, load the driver without it. NetWare will prompt you with available PCI device numbers.

Note that you can specify a Preferred Primary adapter, which in most cases will be your highest bandwidth adapter. See the NW411.TXT file on the CD for more information.

2. Modify the lines to match your server's requirements.
3. Save the AUTOEXEC.NCF file and restart your server.

Deleting a Team

To remove a team in AFT or ALB mode, comment out the command lines above and restart the server.

Setting up Adaptive Load Balancing

Adaptive Load Balancing (ALB) is a simple and efficient way to balance the transmission load of your server among two to eight adapters. With ALB, you group HP NetServer 10/100 adapters in teams. The ALB software continuously analyzes transmit loading on each adapter and balances the rate across the adapters as needed. Adapter teams configured for ALB also provide the benefits of AFT. Receive data is not load-balanced.

NOTE For maximum benefit, ALB should not be used under NetBEUI and some IPX environments. For a list of specific IPX environments supported, see the *Teaming Options Supported by OS and Protocol* section later in this guide.

To use ALB, your adapters must be configured as a team in your server and be connected to the same switch.

Setting up ALB in Windows NT 4.0

1. Double-click the **Network** icon in Control Panel.
2. On the Adapters tab, select an adapter that will be in the team, and then click **Properties**. (Don't use an adapter that is on a VLAN.)
3. In the HPSet window, click the **Adapter Teaming** tab.
4. Click the **Add Adapter to a Team** button.
5. The Teaming Wizard starts. Follow the wizard steps for assigning adapters to a team. Note that you can specify a Preferred Primary adapter, which in most cases will be your highest bandwidth adapter. See the HPSet Help for more information.
6. Click **OK**, then click **Close** to finish. When prompted, restart your server.

Deleting a Team

1. Double-click the **Network** icon in Control Panel.
2. On the Adapters tab, select the ALB team to delete.
3. Click **Remove**. You'll see a confirmation dialog box. Click **Yes**.
4. Click **Close**. Restart when prompted.

NOTE

When IPX is used, the frame type for each adapter in the team reverts to Auto when a team is deleted. You may need to set it to the specific frame type to connect to your network.

Setting up ALB in NetWare

To set up ALB in NetWare, use the instructions in the *Setting up Adapter Fault Tolerance in NetWare* section earlier in this guide, substituting "ALB" for the "Z" parameter.

Setting Up Cisco Fast EtherChannel

Fast EtherChannel (FEC) is a performance technology developed by Cisco to increase throughput between switches. HP has implemented FEC on server adapters to increase your server's throughput. Unlike ALB, FEC can be configured to increase both transmission and reception channels between your server and switch. FEC works only with FEC-enabled Cisco switches, such as the Catalyst 5000 series. With FEC, as you add adapters to your server, you can group them in teams to provide up to 800 Mbps at full duplex, with a maximum of eight HP NetServer 10/100 adapters. (Note that the switch must support more than four adapters in FEC in order for more than four adapters to work in FEC. Consult your switch documentation.) The FEC software continuously analyzes loading on each adapter and balances network traffic across the adapters as needed. Adapter teams configured for FEC also provide the benefits of AFT.

To use FEC, you must have two, four, six or eight HP NetServer 10/100 adapters configured as an FEC Team in your server or workstation and linked to the same FEC-enabled Cisco switch.

Setting up FEC in Windows NT 4.0

1. Double-click the **Network** icon in Control Panel.
2. On the Adapters tab, select a HP NetServer 10/100 adapter that will be in the team and click **Properties**. (Don't use an adapter that is on a VLAN.)
3. In the HPSet window, click the **Adapter Teaming** tab.
4. Click the **Add Adapter to a Team** button.
5. The Teaming Wizard starts. Follow the wizard steps for assigning adapters to a team. Note that you can specify a Preferred Primary adapter, which in most cases will be your highest bandwidth adapter. See the HPSet Help for more information.
6. Click **OK**, then click **Close** to finish. When prompted, restart your computer.

Deleting a Team

1. Double-click the **Network** icon in Control Panel.
2. On the Adapters tab, select the FEC team to delete.
3. Click **Remove**. A confirmation dialog box appears. Click **Yes**.
4. Click **Close**. Restart when prompted.

NOTE

When IPX is used, the frame type for each adapter in the team reverts to Auto when a team is deleted. You may need to set it to the specific frame type to connect to your network.

Setting up FEC in NetWare

To set up FEC in NetWare, use the instructions in the *Setting up Adapter Fault Tolerance in NetWare* section earlier in this guide, substituting "FEC" for the "Z" parameter.

Teaming Options Supported by OS and Protocol

	Windows NT 4.0	NetWare 4.2, 5.0, 5.1
AFT	IP, NetBEUI, IPX(NCP), IPX (NetBIOS)	IP, IPX (NCP), AppleTalk
ALB	IP, IPX (NCP)	IP, IPX (NCP)
FEC	IP, NetBEUI, IPX (NCP), IPX (NetBIOS)	IP, IPX (NCP)

Note that only IPX packets type NCP (NetWare Core Protocol) are load balanced. Under FEC, all protocols can be load balanced.

9 Troubleshooting and FAQs

If the Adapter Can't Connect to the Network

Make sure the cable is installed properly.

The network cable must be securely attached at both RJ-45 connections (adapter and hub). The maximum allowable distance from adapter to hub is 100 meters. If the cable is attached and the distance is within acceptable limits but the problem persists, try a different cable.

If you're directly connecting two servers without a hub or switch, use a crossover cable.

Check the LED lights on the adapter.

The adapter has two diagnostic LEDs, one on each side of the cable connector. These lights help indicate if there's a problem with the connector, cable, or switch/hub.

Responder Testing on the Network (Optional)

Setup can test the adapter more thoroughly if there is a responder on the network while you run the tests.

1. Go to a NetServer on the network with a comparable PCI adapter installed.
2. Run the appropriate configuration program for the installed adapter and set it up as a responder.
3. Return to the server that has the new adapter. Run Setup and test the adapter by running diagnostics.

LED Function Indicators

LED	Meaning
ACT/LNK On	The adapter and switch are receiving power; the cable connection between the switch and adapter is good.
ACT/LNK Off	<p>The adapter and switch are not receiving power or there is a driver configuration problem.</p> <p>If the LED is off:</p> <ul style="list-style-type: none"> • Make sure power is connected to the PC. If power is connected and the LED is still off: • Make sure the WOL cable is attached and power is applied to the computer. • Make sure the network cable is attached at both ends. • Make sure you've loaded the network drivers. • Check all connections at the adapter and the switch and make sure both ends are connected. • Try another port on the switch. • Make sure the duplex mode setting on the adapter matches the setting on the switch. • Make sure you have the correct type of cable between the adapter and the hub. 100BASE-TX requires two pairs. Some hubs require a crossover cable, while others require a straight-through cable. • Make sure you've loaded the correct network drivers.
ACT/LNK Flashing	<p>The adapter is sending or receiving network data. The frequency of the flashes varies with the amount of network traffic.</p> <p>If the ACT/LNK LED does not flash, the cause could be:</p> <ul style="list-style-type: none"> • The network may be idle. Try accessing a server. • The adapter may not be transmitting or receiving data. Try another adapter. • Make sure you're using two-pair cable for TX wiring.
100 On	Operating at 100 Mbps.
100 Off	Operating at 10 Mbps.

Make sure you're using the correct drivers.

Make sure you're using the drivers that come with this adapter. Drivers that support previous versions of this adapter don't support this version of the adapter.

Make sure the switch port and the adapter have the same duplex setting.

If you configured the adapter for full duplex, make sure the switch port is also configured for full duplex. Setting the wrong duplex mode can degrade performance, cause data loss, or result in lost connections.

Testing the Adapter (Diagnostics)

Test the adapter by running diagnostics. For DOS or Windows 3.1, run Setup on the *HP NetServer 10/100TX PCI LAN Adapter Drivers* CD. For Windows NT, run HPSet by double-clicking the **HPSet** icon in the Windows Control Panel. To run diagnostics, select the adapter and click the **Diagnostics** tab, then click **Run Tests**. For additional information, click **Help** in the HPSet window.

Frequently Asked Questions (FAQs)

Setup.exe reports the adapter is "Not enabled by BIOS."

- The PCI BIOS isn't configuring the adapter correctly. See *PCI Installation Tips* earlier in this guide.

The server hangs when the drivers are loaded.

- Change the PCI BIOS interrupt settings. See *PCI Installation Tips* for more information.
- If you are using EMM386, it must be version 4.49 or newer (this version ships with MS-DOS 6.22 or newer).

Diagnostics pass, but the connection fails or errors occur.

- At 100 Mbps, use Category 5 wiring and make sure the network cable is securely attached.

- At 100 Mbps, connect to a 100BASE-TX hub/switch (not 100BASE-T4).
- For NetWare, make sure you specify the correct frame type in your NET.CFG file.
- Make sure the duplex mode setting on the adapter matches the setting on the switch.

The adapter stopped working without apparent cause.

- Run the diagnostics.
- Try reseating the adapter in its slot, or try a different slot if necessary.
- The network driver files may be corrupt or missing. Remove the drivers and then reinstall them.

The Wake on LAN feature is not working.

- Make sure the WOL cable is attached and that power is being applied to the computer.
- Check the BIOS for its WOL setting. Some computers may need to be configured for WOL.
- Make sure the network cable is fully attached to the adapter.

10 Technical Information

PCI Installation Tips

PCI computers are designed to automatically configure add-in cards each time the server starts. Your PCI server sets the I/O address and IRQ level for your network adapter when the server starts. The adapter software cannot change these values. If you experience a problem when the server starts, you may need to follow additional configuration steps.

On some servers, manual configuration is possible through the server's PCI BIOS setup utility. Refer to your server's documentation. You may need to verify or change some BIOS settings.

Some common PCI solutions are listed here:

1. Bus master-enabled slots. On some servers, not all slots are bus master enabled by default. Check your BIOS PCI bus setting. It will be set to either Busmaster or Non-busmastered. Choose **Busmaster**.
2. Reserve interrupts (IRQs) and/or memory addresses for ISA adapters. This prevents PCI cards from trying to use the same settings ISA cards are using. Check your PCI BIOS setup program. There may be IRQ options such as Enable for ISA, Reserve for ISA, or Disable for PCI. This option is sometimes in the Plug and Play area of the BIOS setup.
3. Enable the PCI slot. In some PCI servers, you must use the PCI BIOS setup program to enable the PCI slot. This is especially common in PCI servers with the PhoenixBIOS.
4. Update your PCI BIOS. An updated PCI system BIOS can correct some PCI configuration problems. Call your server manufacturer to see if an updated BIOS version is available for your server.
5. Configure the slot for level-triggered interrupts. The slot the adapter is using must be configured for level-triggered interrupts rather than edge-triggered interrupts. Check

your PCI BIOS Setup program.

Here are some examples of PCI BIOS setup program parameters:

PCI slot #:	<i>Slot where the adapter is installed</i>
Master:	ENABLED
Slave:	ENABLED
Latency timer:	40
Interrupt:	<i>Choose an IRQ from the list</i>
Edge-level:	Level

The exact wording of these parameters varies with different servers.

Removing an Existing Adapter in Windows 2000

If you are replacing an existing adapter with a HP NetServer 10/100 adapter, follow these steps *before* physically removing the adapter card:

1. Double-click **My Computer**.
2. Double-click **Control Panel**.
3. Double-click **System**.
4. Click the **Hardware** tab.
5. Click the **Device Manager** button.
6. Double-click **Network Adapters**.
7. Right-click on the listing for the adapter you want to remove and click **Uninstall**.
8. Click **OK**.
9. Follow the instructions in the section *Installing the Adapter in the NetServer* at the start of this manual.

Removing an Existing Adapter in Windows NT

1. From the Control Panel, double-click the **Network** icon.

2. Click the **Adapters** tab.
3. Under the “Network Adapters” field, highlight the adapter you’re removing and click the **Remove** button.
4. Click **OK**.
5. Follow the instructions in the section *Installing the Adapter in the NetServer* at the start of this manual.

Fast Ethernet Wiring

The 100BASE-TX specification supports 100 Mbps transmission over two pairs of Category 5 twisted-pair Ethernet (TPE) wiring. One pair is used for transmit and the other for receive. Segment lengths are limited to 100 meters with 100BASE-TX for signal timing reasons. This complies with the EIA 568 wiring standard.

Power Management

The selections are ACPI and APM. ACPI should work in most computers.

The APM selection will pre-enable the Wake-on-LAN function of the adapter. Set this selection to APM if one of the following apply:

1. You are having difficulty with remote wake-up in computers that are compliant with the PCI 2.2 specification. You are running an OS that is not ACPI (Advanced Control and Power Interface) aware and you are not using the 3-pin header cable.
2. You are running an ACPI aware OS (such as Windows 98) on a non-ACPI computer and the link light goes out when you shut down the system, disabling Wake-on-LAN.

11 Specifications

Compatibility

PCI v2.2 systems

Data Rate Mode

10 or 100 Mbps

Interrupt Levels

PCI: INTA

SRAM Transmit/Receive Buffer

6 KB

Power Requirements

1.06 Watts @ 5.0VDC

Isolation Voltage

200V RMS

Diagnostic LEDs

Activity/Link, 100 Mbps

Diagnostic Software

On-board HPSet, Setup Responder

Electromagnetic Compliance

USA: CFR 47 part 15, Class B; FCC ID
EJMNPDSPDO35
Canada: Industry Canada, ICES-003, CISPR 22, Class B
EU Countries: EN50081, EN 55022, Class B
Eastern Europe (ISE) Countries: EN55022, Class B
Korea: Min. of Information & Communication, Class B
Japan: VCCI, CISPR 22 Class B ITE
Australia: AS/NZS 3548 - EN 55022

New Zealand: AS/NZS 3548 - EN55022

Taiwan: BCIQ, CISPR 22, Class B

Electromagnetic Immunity

EU Countries: EN50082-1,EU, including:
 ESD, IEC-801-2:1984, 4KV Contact,
 8KV Air, Radiated Immunity, IEC-801-
 3:1984, 3V/m, 80% AM Mod, 27 - 1000
 MHz EFT, IEC-801-4:1988 1.0KV
 Power, 0.5KV I/O lines

Safety Compliance

Meets the requirements of UL 1950, EN60950

Printed Circuit Board: UL 94 V-0

Environmental

Operational Temperature: 0°C to 55°C (32°F to 131°F)

Operational Humidity: 10% to 90% Relative humidity,
 Non-condensing

Non-operational Temperature: -40°C to 65°C (-40°F to 149°F)

Non-operational Humidity: 5% to 95% Relative humidity,
 Non-condensing

Altitude:

Operational -30 to 3045 meters (10,000 feet)

Non-operational -30 to 12180 meters (40,000 feet)

Data Communications

Cable Interface

Specifications

Twisted-pair RJ-45

IEEE 802.3i Type 10Base-T

IEEE 802.3u Type 100Base-T

12 Warranty and Support

The hardware warranty below applies to components purchased as accessories. If your component was factory installed as part of a HP NetServer model, refer to the warranty statement provided with your system documentation.

Hardware Warranty

This HP NetServer accessory is covered by a limited hardware warranty for a period of one year from receipt by the original end-user purchaser.

Once installed in a HP NetServer, this accessory may carry the longer of either a one-year warranty or the remainder of the warranty period for the HP NetServer in which it is installed.

This accessory may be serviced through expedited part shipment. In this event, HP will prepay shipping charges, duty, and taxes; provide telephone assistance on replacement of the component; and pay shipping charges, duty, and taxes for any part that HP asks to be returned.

The customer may be required to run HP-supplied configuration and diagnostic programs before a replacement will be dispatched or an on-site visit is authorized.

Refer to the warranty statement provided with your original HP NetServer system documentation for the warranty limitations, customer responsibilities, and other terms and conditions.

HP Repair and Telephone Support

Refer to the *Service and Support* section of your HP NetServer system documentation for instructions on how to obtain HP repair and telephone support.

NOTE Collect data before contacting your LAN dealer or Hewlett-Packard, as follows:

History:

- What symptoms did you notice?
- Did the symptoms appear when the LAN adapter was first installed, after normal operation, or after its configuration was changed?
- If you changed its configuration, did you also change the driver parameters to match?

Adapter Information:

- Run the adapter utility for the HP NetServer's operating system, Setup or HPSet. Refer to the setup section about your operating system in this manual for information. Record any configuration information.

NetServer Information:

- What vendor and model of HP NetServer are you using?
- What are the processor speed and bus type (EISA/PCI or ISA/PCI)?
- What is the configuration of other cards installed in your HP NetServer?
- What operating system and version are you using?
- What network operating system and version are you using?
- What applications are running on the HP NetServer?
- Find out if an expanded memory manager or memory caching is also running. If possible, get the memory manager to output a map of the HP NetServer's memory.
- List the contents of key files such as AUTOEXEC.BAT, AUTOEXEC.NCF, STARTUP.NCF, CONFIG.SYS, NET.CFG, PROTOCOL.INI, LANMAN.INI, and SYSTEM.INI.

13 Regulatory Information

Notice for United States (Federal Communications Commission)

This equipment has been tested and found to comply with the limits for a Class B digital device, pursuant to Part 15 of the FCC Rules. These limits are designed to provide reasonable protection against harmful interference in a residential installation. This equipment generates and uses, and can radiate radio frequency energy and, if not installed and used in accordance with the instructions, may cause harmful interference to radio communications. However, there is no guarantee that interference will not occur in a particular installation. If this equipment does cause harmful interference to radio or television reception, which can be determined by turning the equipment off and on, the user is encouraged to correct the interference by one or more of the following measures:

- Reorient or relocate the receiving antenna.
- Increase the separation between the equipment and the receiver.
- Connect the equipment into an outlet on a circuit different from that to which the receiver is connected.
- Consult the dealer or an experienced radio/television technician for help.

Hewlett-Packard's system certification tests were conducted with HP-supported peripheral devices and HP shielded cables, such as those you receive with your NetServer. Changes or modifications not expressly approved by Hewlett-Packard could void the user's authority to operate the equipment. Cables used with this device must be properly shielded to comply with the requirements of the FCC.

Notice for Canada (Industry Canada)

This class B digital apparatus meets all requirements of the Canadian Interference-Causing Equipment Regulations.

Cet appareil numérique de la classe B respecte toutes les exigences du Règlement sur le matériel brouilleur du Canada.

Notice for Japan

This equipment is in the Class B category information technology equipment based on the rules of Voluntary Control Council For Interference by Information Technology Equipment (VCCI). Although aimed for residential area operation, radio interference may be caused when used near a radio or TV receiver.

Read the instructions for correct operation.

この装置は、情報処理装置等電波障害自主規制協議会（VCCI）の基準に基づくクラスB情報技術装置です。この装置は、家庭環境で使用することを目的としていますが、この装置がラジオやテレビジョン受信機に近接して使用されると受信障害を引き起こすことがあります。
取り扱い説明書に従って正しい取り扱いをして下さい。

Notice for Korea

Class A Equipment :

Please note that this equipment has been approved for business purposes with regards to electromagnetic interference, if purchased in error for use in residential area, you may wish to exchange the equipment where you purchased it.

Class B Equipment :

Please note that this equipment has been approved for non-business purposes with regards to electromagnetic interference. This equipment can be allowed for use in all areas as well as residential areas.

사용자 안내문 (B급 기기)

이 기기는 비업무용으로 전자파 장애검정을 받은 기기로서, 주거 지역에서는 물론 모든 지역에서 사용 할 수 있습니다.

Notice for Taiwan

Class A Warning Statement

警告使用者：
這是甲類的資訊產品，在居住的環境中使用時，可能會造成射頻干擾，在這種情況下，使用者會被要求採取某些適當的對策。

Declaration of Conformity (US and EU)

DECLARATION OF CONFORMITY	
according to ISO/IEC Guide 22 and EN 45014	
Manufacturer's/Supplier Name:	Hewlett-Packard Company
Manufacturer's/Supplier Address:	10955 Tantau Avenue Cupertino, CA 95014-5040 USA
declares, that the product	
Product Name:	Network Interface CardNetServer 10/100 NIC
Model Number(s):	HP NetServer 10/100TX PCI LAN Adapter
Product Options:	ALL
conforms to the following Product Specifications:	
Safety:	IEC 950: 1991+A1, A2, A3, A4 / EN 60950: 1992+A1, A2, A3, A4, ALL
EMC:	CISPR 22:1993 +A1 +A2 / EN 55022:1994, Class B GB9254-1988 EN 50081-1:1992 - Generic Emissions EN 50082-1:1992 - Generic Immunity IEC 801-2:1991, 4 kV CD, 8 kV AD IEC 801-3:1984, 3 V/m IEC 801-4:1988, 0.5 kV Signal Lines, 1 kV Power Lines
	FCC Title 47 CFR, Part 15, Class B
Supplementary Information:	
1) The product was tested in a typical configuration with Hewlett-Packard peripherals.	
2) The product complies with Part 15 of the FCC rules. Operation is subject to the following two conditions:	
<ul style="list-style-type: none"> • This device may not cause harmful interference, and • This device must accept any interference received, including interference that may cause undesired operation. 	
The product herewith complies with the requirements of the following directives and carries the CE marking accordingly:	
<ul style="list-style-type: none"> - EMC Directive 89/336/EEC - Low Voltage Directive 73/23/EEC - LED's in this product(s) are Class-1 in accordance with EN60825-1:1994. 	
Cupertino August 1, 1998	
 <hr style="width: 20%; margin: auto;"/>	
Nigel Marrion/Quality Manager	
North American Contact: Hewlett-Packard Company Product Regulations Manager, 3000 Hanover Street, Palo Alto, CA 94304 Phone: 415-857-1501	
European Contact: Your local Hewlett-Packard Sales and Service Office or Hewlett-Packard GmbH, Herrenberger Straße 130, D-71034 Böblingen (FAX: + 49-7031-143143)	

A Quick Install Guide in Chinese

1. 安裝 HP 配接卡

- 1 關閉電腦並拔掉電源插頭。
- 2 從 PCI 插槽將電腦蓋和框架移除。
- 3 穩固地將 HP 配接卡插入 PCI 插槽並固定框架。

2 選擇性地接上 Wake on LAN (WOL) 電纜線

- 1 確認電腦已經關閉，電源線也已拔除

注意：) WOL 接頭即使在電腦關閉時仍然會有電壓供應

- 2 將 WOL 電纜線的一邊連接到配接卡上的 WOL 接頭。
- 3 將另外一邊的 WOL 電纜線連接到主機板上的 WOL 接頭。
- 4 將電腦蓋放回去。

3. 連接網路電纜線

- 1 使用 10 Mbps 網路的“類別 3、4、或 5 總結配對乙太網”(TPE) 網路電纜線、在 100 Mbps 網路或 10 或 100 Mbps 常駐網路僅使用“類別 5 TPE”將電纜線連接到配接卡。
- 2 插入電源線並重新啟動您的電腦。

4. 安裝網路驅動程式

“隨插即用”電腦會在開機時自動偵測和設定“隨插即用”配接卡。配接驅動程式安裝期間，HP HPSet 公用程式會自動安裝。HPSet 可以讓您設定和測試您的 HP 配接卡。同時也會顯示指定給每個安裝之配接卡的電腦資源。

Windows* 2000

- 1 將您的 HP 配接卡光碟片插入。Windows* 2000 會從其本身的驅動程式庫為配接卡自動安裝驅動程式。

注意：) 安裝程序已經完成，除非您的 HP 配接卡有“套件保護”功能。要使用此功能，您必須用包括在 HP 配接卡光碟片上的驅動程式更新網路驅動程式。如果此功能是您 HP 配接卡的一部份，請進行步驟 2。
- 2 從「控制台」，連續按兩下「系統」圖示，選取「硬體」字標，再按一下「裝置管理員」按鈕。
- 3 選取「網路配接卡」，在您的配接卡上按一下滑鼠右鍵來顯示其功能表，然後按一下「內容」功能表選項
- 4 從「內容」對話方塊，按一下「驅動程式」並按一下「更新驅動程式」按鈕。「更新裝置驅動程式精靈」會出現。按一下「下一步」。
- 5 在「您要精靈做什麼？」的提示下，選取「搜尋適合我的裝置的驅

- 動程式」圓形按鈕，再按一下「下一步」。
- 6 選取您的光碟機並按一下「下一步」。
 - 7 選取「安裝其中一個驅動程式」核取方塊，然後按一下「下一步」。
 - 8 選取 **HP** 配接卡光碟片上的驅動程式並按一下「下一步」。
 - 9 重新啓動您的電腦。

Windows NT* 4.0

- 1 啓動 Windows NT* 4.0，連續按兩下「控制台」中的「網路」圖示，按一下「配接卡」，再按一下「新增」。
- 3 當您看到配接卡的清單時，請不要從清單選擇配接卡，請將您的 **HP** 配接卡光碟片插入，然後按一下「從磁片安裝」。
- 4 如果「**HP** 產品設定」螢幕出現的話，請將其關閉並繼續進行。
- 5 指定路徑，按一下「確定」，並繼續安裝。完成時，您會在「網路配接卡」清單看到新的 **HP** 配接卡。
- 6 按一下「關閉」來完成作業。
- 7 重新啓動您的電腦。

Windows NT 3.5x

- 1 啓動 Windows NT 3.5x，開啓「控制台」，然後連續按兩下「網路」圖示。
- 2 選取「新增配接卡」，捲動到清單的下面，然後按一下<其它>。
- 3 將您的 **HP** 配接卡光碟片插入，按一下「確定」來完成安裝。
- 4 重新啓動您的電腦。

法規資訊

這項裝置已經經過測試，結果發現其符合 FCC 規則15 篇，B 級數位裝置的規定。要檢視完整的“EMC 法規資訊”，請參考您的 **HP** 配接卡光碟片上的Manuals 目錄。

Index

8

802.3i, 1
802.3u, 1

A

Adapter
 Ethernet address, 21
Adapter Fault Tolerance, 30
Adapters
 multiple, 21
Adaptive Load Balancing, 33
Adaptive Load Balancing NT
 4.0, 34
Adaptive Load Balancing,
 NetWare, 34
Adding a VLAN in Windows
 2000, 27
Adding a VLAN in Windows
 NT 4.0, 26
AFT, 1
ALB (Adaptive Load
 Balancing), 1

C

**Can't Connect to the
 Network**, 37
Choosing Adapter Teaming
 Options, 29
Compatibility
 802.3i, 1
 802.3u, 1
Configuring for Full Duplex,
 24
Configuring the Adapter and
 Installing Drivers, 11
Connecting the Network
 Cable, 7

D

Diagnostics, 39
DMI (Desktop Management
 Interface), 2

E

Environmental specifications,
 49

F

Fast EtherChannel, 35
FEC (Faster EtherChannel), 1
FEC in NetWare, 36
Frequently Asked Questions,
 39

G

General Configuration Notes,
 29
General Configuration Notes,
 26
Getting help, 47

H

Hardware repair
 warranty information for,
 47
Hardware Warranty, 47
Help, 47
HP NetServer 10/100TX PCI
 LAN Adapter for PCI
 Systems, 1
HPSet, 17

I

Installing the Adapter in the
 NetServer, 5

interference, 49

J

Join a Virtual LAN, 25

M

MAC address, 21

N

NetWare Adapter Fault
Tolerance, 31

NetWare Users, 21

Node address, 21

Novell NetWare 4.1x or 4.2,
12

Novell NetWare 5.0, 11

NT 4.0 Adapter Fault
Tolerance, 30

P

Parts, 2

PCI Installation, 41

PCI slot number, 21

Power Management, 43

Priority Packet, 18

Q

Quick Install Guide, 53

R

Readme files. *See* Drivers CD

Regulatory information, 49

Removing an Existing Adapter
in Windows 2000, 42

Removing an Existing Adapter
in Windows NT, 42

Repair and Telephone
Support, 47

S

Selecting Duplex Mode, 23

Service and Support, 3

Setup Floppy Disk, 10

SNMP (Simple Network
Management Protocol), 2
Specifications, 45

Standards

PCI 2.1, 1

Plug-and-Play, 1

T

Teaming Options, 36

Technical Information, 41

Troubleshooting, 37

Adapter can't connect, 37

U

UNIX, Banyan VINES, and
Other Operating Systems,
17

Using Wake on LAN, 9

W

Wake on LAN Power Cable, 8

Warranty information

hardware, 47

Web site. *See*

<http://www.hp.com/netserver/support>

Where to Go for More

Information, 3

Windows 2000, 13

Windows NT 3.51 Users, 21

Windows NT Automatic
Configuration, 14

Windows NT Troubleshooting,
16

Wiring, Fast Ethernet, 43

Free Manuals Download Website

<http://myh66.com>

<http://usermanuals.us>

<http://www.somanuals.com>

<http://www.4manuals.cc>

<http://www.manual-lib.com>

<http://www.404manual.com>

<http://www.luxmanual.com>

<http://aubethermostatmanual.com>

Golf course search by state

<http://golfingnear.com>

Email search by domain

<http://emailbydomain.com>

Auto manuals search

<http://auto.somanuals.com>

TV manuals search

<http://tv.somanuals.com>