

HP A5150A PCI Dual Port Ultra2 SCSI Host Bus Adapter

Service and User Guide

Edition 2

Customer Order Number: A5150-90001



Manufacturing Part Number: A5150-96002

E0201

U.S.A.

© Copyright 2001, Hewlett-Packard Company.

Legal Notices

The information in this document is subject to change without notice.

Hewlett-Packard makes no warranty of any kind with regard to this manual, including, but not limited to, the implied warranties of merchantability and fitness for a particular purpose. Hewlett-Packard shall not be held liable for errors contained herein or direct, indirect, special, incidental or consequential damages in connection with the furnishing, performance, or use of this material.

Warranty. A copy of the specific warranty terms applicable to your Hewlett-Packard product and replacement parts can be obtained from your local Sales and Service Office.

Restricted Rights Legend. Use, duplication or disclosure by the U.S. Government is subject to restrictions as set forth in subparagraph (c) (1) (ii) of the Rights in Technical Data and Computer Software clause at DFARS 252.227-7013 for DOD agencies, and subparagraphs (c) (1) and (c) (2) of the Commercial Computer Software Restricted Rights clause at FAR 52.227-19 for other agencies.

HEWLETT-PACKARD COMPANY
3000 Hanover Street
Palo Alto, California 94304
U.S.A.

Use of this manual and flexible disk(s) or tape cartridge(s) supplied for this pack is restricted to this product only. Additional copies of the programs may be made for security and back-up purposes only. Resale of the programs in their present form or with alterations, is expressly prohibited.

Copyright Notices. ©copyright 1983-2001 Hewlett-Packard Company, all rights reserved.

Reproduction, adaptation, or translation of this document without prior written permission is prohibited, except as allowed under the copyright laws.

©copyright 1979, 1980, 1983, 1985-93 Regents of the University of California

This software is based in part on the Fourth Berkeley Software Distribution under license from the Regents of the University of

California.

©copyright 1980, 1984, 1986 Novell, Inc.

©copyright 1986-1992 Sun Microsystems, Inc.

©copyright 1985-86, 1988 Massachusetts Institute of Technology.

©copyright 1989-93 The Open Software Foundation, Inc.

©copyright 1986 Digital Equipment Corporation.

©copyright 1990 Motorola, Inc.

©copyright 1990, 1991, 1992 Cornell University

©copyright 1989-1991 The University of Maryland

©copyright 1988 Carnegie Mellon University

Trademark Notices UNIX is a registered trademark of The Open Group.

X Window System is a trademark of the Massachusetts Institute of Technology.

MS-DOS and Microsoft are U.S. registered trademarks of Microsoft Corporation.

OSF/Motif is a trademark of the Open Software Foundation, Inc. in the U.S. and other countries.

1. HP A5150A Adapter Overview

About the A5150A Adapter	9
Features	10
Interface Descriptions	11
The PCI Interface	11
The SCSI Interface	11
The Wide Ultra2 SCSI Interface	12
Supported HP 9000 and HP e3000 Servers	13
Cable Specifications	14

2. Installing the A5150A Adapter

Preparing for Installation	17
Handling the A5150A Adapter	18
Looking at Adapter Installation	19
Before You Start	19
Install Using OLAR (HP-UX 11i).....	20
Install/Replace With System Powered Down	25
Connecting the SCSI Peripherals	27
Making External SCSI Bus Connections.....	27
Making Internal SCSI Bus Connections	28
SCSI Bus Termination.....	29
Auto Termination Information.....	29
Bus Termination	30
When and How to Turn Off Auto Termination	31
Setting SCSI IDs.....	35
Verifying Installation.....	37

3. Troubleshooting

General Procedure	41
Checking SCSI Bus Compatibility	42
The SCSI Command	43
Using Support Tools Manager (STM)	47
Contacting Your Hewlett-Packard Representative	48

A. SCSI Sense Codes**B. Regulatory Information**

Regulatory Statements	68
-----------------------------	----

Contents

FCC Statement (For U.S.A. Only)	68
IEC Statement (Worldwide)	68
DOC Statement (Canada)	68
Spécification ATI Classe A (France	69
VCCI Statement (Japan)	69
Declaration of Conformity	70

Glossary

1 HP A5150A Adapter Overview

This chapter contains the following sections that describe the HP A5150A PCI Dual Port Ultra2 SCSI host bus adapter (HBA):

- “About the A5150A Adapter” on page 9.

- “Features” on page 10.
- “Interface Descriptions” on page 11.
- “Supported HP 9000 and HP e3000 Servers” on page 13.
- “Cable Specifications” on page 14.

About the A5150A Adapter

The A5150A Dual Channel PCI Ultra2 SCSI host adapter board provides two SCSI-3 Ultra2 SCSI interfaces to PCI computer systems that require BIOS support on the add-in SCSI adapter. Installing this adapter in your PCI system allows connection of SCSI devices over a SCSI bus.

The dual channel A5150A board provides 16-bit Low Voltage Differential (LVD) and 16-bit Single-Ended (SE) SCSI solutions for your system using only one PCI slot. This board supports legacy Fast SCSI devices, Ultra SCSI devices, and the newest Ultra2 SCSI devices.

Consult with your Hewlett-Packard representative for more information on specific system configurations.

Figure 1-1 below is a drawing of the A5150A adapter.

Figure 1-1 The A5150A PCI Ultra2 SCSI Host Bus Adapter

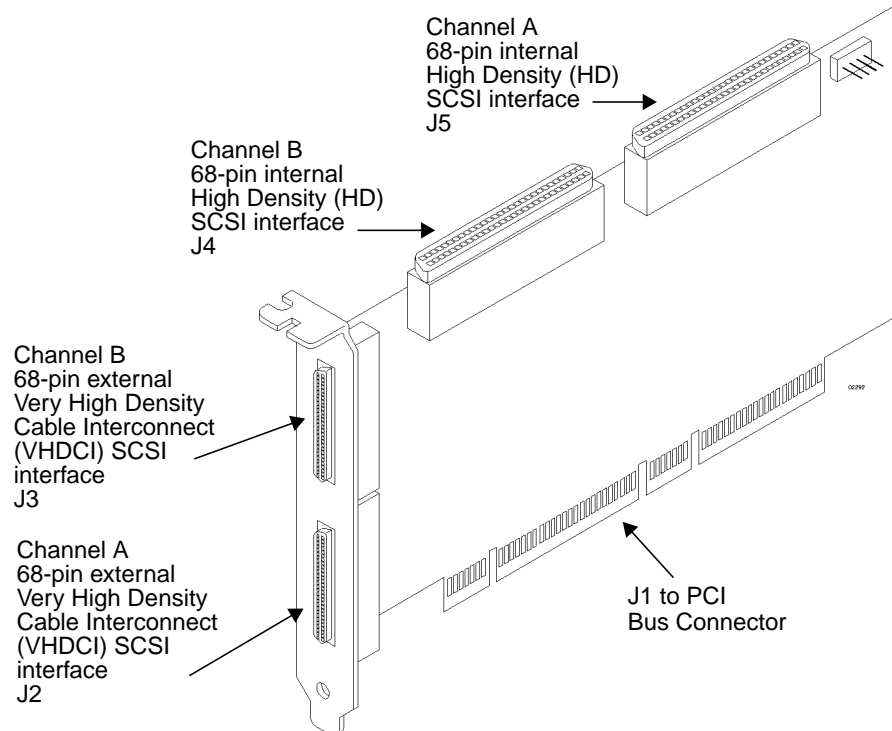

Features

The A5150A adapter has the following features:

- PCI interface
 - Full 32-bit or 64-bit (33 MHz) Direct Memory Access (DMA) bus master.
 - Zero wait-state bus master data bursts.
 - PCI Universal 3.3V/5V bus support.
- SCSI interface
 - Two separate SCSI ports.
 - 16-bit single-ended (SE)/Low Voltage Differential (LVD)
 - Automatically enabled termination.
 - 68-pin Very High Density Cable Interconnect (VHDCI) connector for each of the two external channels.
 - 68-pin High Density connector for each of the two internal channels.
 - Fast, Ultra, and Ultra2 data transfer capability.
 - SCSI TERMPWR source with auto-resetting current-limiting device and TERMPWR shorted LED for each channel (not visible externally).
 - SCSI Plug and Play.
 - Flash EEPROM for BIOS storage.
 - Serial non-volatile random access memory (NVRAM) on each channel, for user configuration utility and SCAM information storage.
 - SCSI activity LED for each channel (not visible externally).
- Board characteristics
 - PCI board dimensions: approximately 9.5 inches x 4.0 inches.
 - Universal 64-bit PCI card edge connector.
 - ISA/EISA bracket.

Interface Descriptions

This section provides greater detail about the PCI, SCSI, and Wide Ultra2 SCSI interfaces.

The PCI Interface

PCI is a high-speed standard local bus for interfacing a number of I/O components to a processor and memory subsystem. The PCI functionality for the A5150A is contained within the I/O Processor Chip. The adapter connects directly to the PCI bus and generates timing protocol in compliance with the PCI application.

The PCI interface operates as a 32-bit or 64-bit DMA bus master. The connection is made through the edge connector J1 (see Figure 1-1 on page 9). The signal definitions and pin numbers conform to the PCI Local Bus Specification Revision 2.1 standard. The A5150A conforms to the PCI universal signaling environment for a 5 volt or 3.3 volt PCI bus.

The SCSI Interface

The SCSI functionality for the A5150A is contained within the PCI-SCSI I/O Processor Chip. The adapter connects directly to the two SCSI buses for 16-bit SE or LVD SCSI applications and generates timing and protocol in compliance with the SCSI standard. Each SCSI interface operates at a burst transfer rate of up to 40 MBytes per second for wide single-ended transfers, and up to 80 MBytes per second for wide LVD SCSI transfers.

The two SCSI interfaces on the host bus adapter card operate as 16-bit, synchronous or asynchronous, single-ended or LVD, and support Ultra2 SCSI protocols and 16-bit arbitration. The interface is made through connectors J2 and J5 for channel A and J3 and J4 for channel B. Connectors J2 and J3 are 68-pin, VHDCI right-angle receptacles that protrude through the ISA/EISA bracket.

The adapter supplies SCSI bus TERMPWR (termination power) through a blocking diode and auto-resetting current-limiting device. Each SCSI channel has two LEDs to indicate the terminator's power (TERMPWR) status. The TERMPWR Good (Channel A or B) LED indicates when the termination power is above 3.0 volts. The TERMPWR Shorted LED

Interface Descriptions

indicates when the termination power was subjected to an over current condition causing the self-resetting current limiting device (circuit breaker) to trip.

A 40 MHz oscillator is installed on the A5150A card to provide the clock frequency necessary to support Wide Ultra2 SCSI transfers of up to 80 MBytes per second.

The Wide Ultra2 SCSI Interface

The adapter card has full support for Wide Ultra2 SCSI. This interface is an extension of the SCSI-3 family of standards that expands the bandwidth of the SCSI bus to allow faster synchronous data transfers, up to 80 MBytes per second. Wide Ultra2 SCSI provides a doubling of the data rate over the Ultra2 SCSI interface, increases the possible cable lengths, and also allows a larger number of devices on the cable than Ultra2 SCSI interfaces.

Special SCSI cables are specified for operation with Wide Ultra and Ultra2 SCSI devices. You must consider the total number of devices and the length of your SCSI bus when setting up your system. The section "Connecting the SCSI Peripherals" on page 27 provides a more detailed explanation of SCSI bus connections.

Supported HP 9000 and HP e3000 Servers

Table 1-1 below shows the HP 9000 and HP e3000 servers the A5150A adapter is supported in.

Table 1-1 **A5150A Supported HP 9000 and HP e3000 Servers**

HP 9000 Server	HP-UX Operating System	MPE/iX Operating System
L-Class	11.0 (or greater) and 11i	
N-Class	11.0 (or greater) and 11i	7.0 and later

Note that the maximum number of SCSI HBAs you can install in any HP 9000 or HP e3000 server is equal to the maximum number of corresponding card slots in the server. For example, if you are installing SCSI PCI HBAs and the server has four PCI card slots, you can install four SCSI PCI HBAs in that server.

Cable Specifications

The A5150A adapter supports Low Voltage Differential (LVD) or single-ended (SE) connections.

Table 1-2 below shows the cables to use when connecting external SCSI peripheral devices to the A5150A adapter.

Table 1-2

Cables for Connecting External SCSI Devices to the A5150A Adapter

Description	Product Number	Option
1-meter 68-pin VHDCI to 68-pin HD SCSI cable	A3401A	811
2.5-meter 68-pin VHDCI to 68-pin HD SCSI cable	A3401A	812
5-meter 68-pin VHDCI to 68-pin HD SCSI cable	A3401A	813
10-meter 68-pin VHDCI to 68-pin HD SCSI cable	A3401A	814

2

Installing the A5150A Adapter

This chapter contains the following sections that describe how to install the A5150A adapter:

- “Preparing for Installation” on page 17.

- “Handling the A5150A Adapter” on page 18.
- “Looking at Adapter Installation” on page 19.
- “Connecting the SCSI Peripherals” on page 27.
- “SCSI Bus Termination” on page 29.
- “Verifying Installation” on page 37.

NOTE

This manual provides installation instructions and technical information for qualified personnel who maintain or service HP 9000 servers. Installing the adapter requires proficiency in both hardware configuration and software administration.

Preparing for Installation

Installing the host bus adapter requires disassembly of some server components. Before beginning installation, refer to the system server manual for detailed instructions on installing host bus adapters in the PCI slots.

You will need the following things:

- ✓ One HP A5150A SCSI adapter.
- ✓ One grounding (ESD) strap.
- ✓ Any other tools needed for installing components in the HP 9000 system (for example, screwdrivers); see the system's documentation.

Handling the A5150A Adapter

The host bus adapter is packaged with an ESD kit, which contains materials to prevent damage from static electricity during installation.

CAUTION

The adapter is highly susceptible to damage by electrostatic discharge during installation and routine maintenance procedures. Do not handle circuit boards without wearing a wrist strap fastened to a good earth ground or to the system chassis.

While you are installing the A5150A adapter, please follow these precautions:

- ✓ Keep the adapter in its shielded antistatic bag until you are ready to install it.
- ✓ Use a wrist strap or other ESD protection. Wrap the strap around your wrist and attach the copper end to a metal portion of the computer frame.
- ✓ Avoid working in carpeted areas.
- ✓ Gently place the adapter, printed circuit board (PCB) side down, on an antistatic work surface pad.
- ✓ Hold the adapter only by its sides or cover plate. Do not touch any components on the printed circuit board assembly (PCBA).
- ✓ Do not use any test equipment to check the components on the PCB.
- ✓ Do not bump, jar, or drop the adapter. Do not place other objects on top of the adapter.
- ✓ Transport the adapter in its shielded bag in an appropriate shipping container. Do not put other materials in the bag with the adapter.

Looking at Adapter Installation

Installation can be performed in one of two ways:

- Use the OLAR (On Line Add/Replace) capability (HP-UX 11i). Refer to “Install Using OLAR (HP-UX 11i)” on page 20.
- Power down the system and then add or replace the HBA. Refer to “Install/Replace With System Powered Down” on page 25.

The method you choose will depend on your situation, the card you are installing, and your requirements.

Before You Start

For safe and proper installation, do the following:

Look through the task list below to get an overall idea of the steps to perform.

1. Determine whether or not you can use the OLA/R (On Line Addition [and] Replacement) method to install the HBA (see “Install Using OLAR (HP-UX 11i)” on page 20).
2. Remove the SPU/system cabinet cover on the system to access the PCI slots. Refer to the system server manual for accessing PCI slots.
3. Insert the host bus adapter.
4. Connect the SCSI peripherals.
5. Terminate the external SCSI bus.
6. Set the peripheral SCSI IDs.
7. Make any configuration changes.
8. Replace the SPU/system cabinet cover.

The SCSI host bus adapter acts on the server’s behalf as the host to the suite of SCSI peripherals. Each chain of SCSI peripheral devices and their host bus adapter work together and are referred to as a SCSI bus.

Each channel on your SCSI host bus adapter can act as host for up to 15 peripheral devices (depending on the SCSI bus speed), not including the adapter itself.

NOTE

The host bus adapter card is supported on the HP N4000 N-class system. Refer to the Hewlett-Packard eproducts web site (<http://www.eproducts.hp.com>) to disassemble the system, install the adapter in an available PCI slot, and reassemble the system.

Install Using OLAR (HP-UX 11i)

The letters O, L, A and R stand for On Line Addition [and] Replacement. This refers to the ability of a PCI I/O card to be installed (replaced or added) in an HP-UX computer system designed to support this feature without the need for completely shutting down, then re-booting the system or adversely affecting other system components. The system hardware uses the per-slot power control combined with operating system support in HP-UX 11i to enable this feature.

IMPORTANT

Certain “Classes” of hardware are not intended for access by users. At this time this includes V-Class and SuperDome systems. HP recommends that these systems only be opened by a qualified HP Engineer. Failure to observe this requirement can invalidate any support agreement or warranty to which the owner might otherwise be entitled.

Important Terms and Concepts

The addition or replacement of an OLAR-compatible card may be done in either one of two ways:

1. Using the SAM utility.
2. Issuing command-line commands using `rad`.

For detailed information about the use of either of these two procedures, please refer to the following document:

Configuring HP-UX For Peripherals, HP Part Number B2355-90698

This document may be ordered from HP, or you may view, download and print it from the following website: www.docs.hp.com

Table 2-1 **Important Terms**

Term	Meaning
OLAR	All aspects of the OLAR feature including On-line Addition (OLA) and On-line Replacement (OLR).
Power Domain	A grouping of 1 or more interface card slots that can be powered on or off as a unit. (NOTE: Multi-slot power domains are not currently supported)
target card / target card slot	The interface card which will be added or replaced using OLAR, and the card slot in which it resides.
affected card / affected card slot	Interface cards and the card slots in which they reside, and which are in the same power domain as the target slot.

IMPORTANT

In many cases, other interface cards and slots within the system are dependent upon the target card. For example:

If the target card is a multiple-port card, suspending or deleting drivers for the target card slot also suspends individual drivers for the multiple hardware paths on that card).

During a card replacement operation, SAM performs a *Critical Resource Analysis*, which checks all ports on the target card for critical resources that would be temporarily unavailable while the card is shut down.

Planning and Preparation

SAM will, generally, prevent you from performing OLAR procedures that would adversely affect other areas of the server. Refer to *Configuring HP-UX For Peripherals*, HP Part Number B2355-90698 for detailed information.

Critical Resources Because power to the slot must be off when the old card is removed and the new card is inserted, the effects of shutting down the card's functions must be carefully considered.

This is particularly important if there is no on-line failover or backup card to pick up those functions. For example:

- Which mass storage devices will be temporarily disconnected when the card is shut down?
- Will a critical networking connection be lost?

A critical resource is one that would cause a system crash or prevent the operation from successfully completing if the resource were temporarily suspended or disconnected. For example, if the SCSI adapter to be replaced connects to the unmirrored root disk or swap space, the system will crash when the card is shut down.

During an OLAR procedure, it is essential to check the targeted card for critical resources, as well as the effects of existing disk mirrors and other situations where a card's functions can be taken over by another card that will not be affected.

Fortunately SAM performs a thorough critical resource analysis automatically, and presents options to you based on its findings. If you determine that critical resources *will* be affected by the procedure, you should replace the card when the server is off-line.

If you must take action immediately, you can use `rad` to attempt an on-line addition of a backup card and deletion of the target card.

Card Compatibility

On-Line Addition (OLA). When on-line adding an interface card, the first issue that must be resolved is whether the new card is compatible with the system. Each PCI slot provides a set amount of power. The replacement card cannot require more power than is available.

The card must also operate at the slot's bus frequency. A PCI card must run at any frequency lower than its maximum capability; however, a

card that operated at a maximum of 33 MHz would not work on a bus running at 66 MHz. `rad` provides information about the bus frequency and power available at a slot, as well as other slot-related data.

On-Line Replacement (OLR) When on-line replacing an interface card, the replacement card must be identical to the card being replaced or at least be able to operate using the same driver as the replaced card. This is referred to as *like-for-like* replacement and should be adhered to because using a similar but not identical card may cause unpredictable results. For example, a newer version of the target card which is identical in terms of hardware may contain an updated firmware version that could potentially conflict with the current driver.

The PCI specification allows a single physical card to contain more than one port. A single-port SCSI bus adapter can not be replaced by a dual-port adapter, even if the additional port(s) on the card are identical to the original SCSI bus adapter.

When the replacement card is added to the system, the appropriate driver for that card must be configured in the kernel before beginning the operation. SAM ensures the correct driver is present. (In most cases, the replacement card will be the same type as a card already in the system, and this requirement will be automatically met.) If you have any question about the driver's presence, or if you are not certain that the replacement card is identical to the existing card, you can use `ioscan` together with `rad` to investigate.

- If the necessary driver is not present and the driver is a dynamically loadable kernel module (DLKM), you can load it manually. Refer to the section "Dynamically Loadable Kernel Modules" in Chapter 2 of the document: *Configuring HP-UX For Peripherals*, HP Part Number B2355-90698 for more information.
- If the driver is static and not configured in the kernel, then the card cannot be On-line Added. The card could be physically inserted on-line, but no driver would claim it.

OLA/R Restrictions for the A5150A

Currently there are two versions of the A5150A:

- A5150-60001 (older)
- A5150-60101 (newer)

Both of the HBAs have some restrictions in the OLA/R procedure. These restrictions are explained below.

Generally, the restrictions are necessary because the SCSI attributes of *initiator ID*, *speed*, and *auto termination* cannot be changed online for this HBA.

OLA of A5150-60001 This HBA can be online added *only* if the SCSI attribute values of `initiator ID` and `speed` are usable in your configuration. These values will be set to the current PDC (Processor Dependent Code) values (if any) or default to the new HBA's values (see Table 2-2).

Table 2-2 A5150-60001 - Default SCSI Attribute Values

Attribute	Default Value
Initiator ID	7
Speed	Ultra2
Auto Termination	A5150-60001 Enabled or Jumper Controlled (HP would prefer that you <i>not</i> use the jumper settings) A5150-60101 Enabled

If these attributes are not acceptable, you must reboot the system to access the Boot Console Handler (BCH) prompt and then change the values in the PDC.

OLA of A5150-60101 This HBA *cannot* be online added.

OLR of A5150-60001 The online replacement operation preserves the initiator ID and speed settings across the replacement. The auto termination setting for this HBA is over-riden by the jumper settings on the board.

Before installation, *ensure* that the auto termination jumpers are set to the same position as they were on the replaced HBA.

Besides the cautions noted above, the A5150-60001 can be Online Replaced without special considerations. See the *Configuring HP-UX Peripherals* manual for the steps that are necessary to OLR this HBA.

OLR of A5150-60101 the A5150-60101 can be Online Replaced with one special consideration.

The HBA being replaced **MUST** have been running with auto termination enabled.

If the above condition is met, you may OLR the HBA. See the *Configuring HP-UX Peripherals* manual for the steps that are necessary to OLR this HBA.

NOTE

Until you complete the OLR, additional SCSI error messages might be written to the `/var/adm/syslog.log` file. Do not be concerned about these messages; they do not affect the result of the OLR process.

Install/Replace With System Powered Down

Check the manual supplied with the server to perform the following installation:

- Step 1.** Shut down the operating system.
- Step 2.** Power off the system and unplug power cords for all components in the server.
- Step 3.** Locate the PCI slots for your server. Remove any cabinet cover.

CAUTION

The adapter is highly susceptible to damage by electrostatic discharge during installation and routine maintenance. Do not handle circuit boards without wearing a wrist strap fastened to a good earth ground or to the system chassis.

NOTE

A 32-bit slot will work; however, full performance requires a 64-bit slot. Refer to the documentation for your server to confirm the location of the PCI slots. The A5150A host bus adapter requires a PCI slot that allows bus master operation.

Step 4. Remove the blank panel aligned with the PCI slot you intend to use. If the blank panel has a bracket screw, save it for reuse during the installation.

Before proceeding to the next step, ground yourself to prevent the possibility of electrostatic discharge damaging the board.

Step 5. Remove the A5150A Dual Channel PCI to Ultra2 SCSI host bus adapter from its packing and check that it is not damaged.

Step 6. Carefully insert the edge connector J1 (see Figure 1-1 on page 9) of the host bus adapter into the PCI slot. Make sure the edge connector is properly engaged before pressing the board into place.

NOTE

You may notice that the components on a PCI host adapter face the opposite way from those on other non-PCI adapter boards you have in your system. This is correct, and the board is keyed to go in only one way.

Step 7. The card's bracket (with connectors J2 and J3) should fit where the blank panel was removed. Secure the bracket with the bracket screw from the blank panel, if there is one.

NOTE

For N-Class systems, a screw is not used to secure the card.

Connecting the SCSI Peripherals

All external SCSI bus connections to the A5150A host bus adapter are made with shielded, 68-conductor cables. The connectors on this cable are always keyed to ensure proper mating.

Some internal cables come with 16bit SE/LVD on one end. This end should be farthest from the host bus adapter.

Figure 2-1 **SCSI Cable**

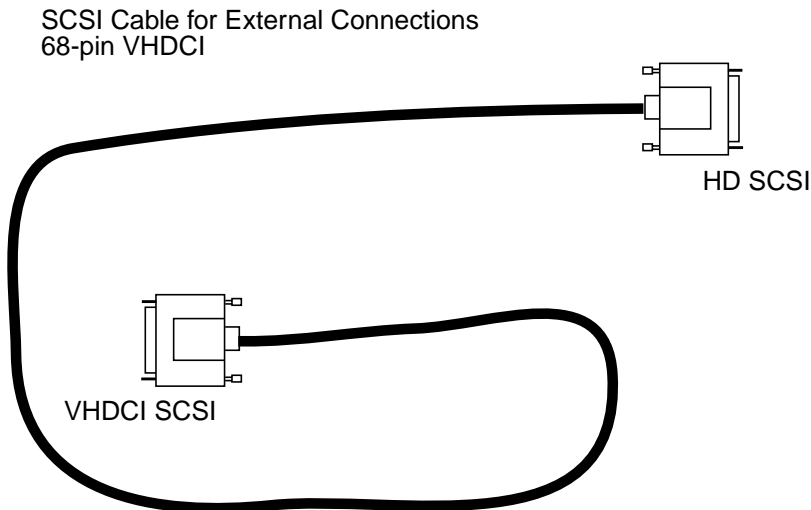

Making External SCSI Bus Connections

Step 1. To connect external SCSI devices to the A5150A host bus adapter, plug the 68-pin VHDCI connector on one end of a shielded external high density SCSI cable into the host bus adapter connector J2 or J3.

This connector is now bracketed onto the back panel of the system.

Step 2. Plug the 68-pin connector on the other end of the shielded external SCSI cable into the SCSI connector on your external SCSI device.

- Step 3.** If you need to connect more than one external SCSI device to your host bus adapter, chain them together with shielded external SCSI cables.

If auto termination has been disabled and you wish to terminate an external connector on the HBA, use HP product number A5296A, VHDCI LVD/SE terminator.

Making Internal SCSI Bus Connections

- Step 1.** Identify pin 1 on adapter connector J4 or J5 (internal 68-pin SCSI connector). Pin 1 of the connector is typically marked by the number 1 or a small triangle.
- Step 2.** Identify pin 1 on either end of a 68-pin SCSI ribbon cable. Pin 1 is typically marked with a contrasting color on the pin-1 end of the cable connector (for example, red).
- Step 3.** After assuring pin-1 orientation, attach the SCSI cable to the 68-pin internal adapter connector (J4 or J5). Connector the other end of the cable to the SCSI connector on the internal peripheral device.
- Step 4.** If you need to connect more than one internal SCSI device to your host bus adapter, you can chain them together (connect them serially).
- Step 5.** Refer to “SCSI Bus Termination” on page 29 for information on termination.

If auto termination has been disabled and you wish to terminate an internal connector on the HBA, use HP product number C2370A, SCSI LVD/SE VHDTS68 terminator.

SCSI Bus Termination

The devices that make up the SCSI bus are connected serially (chained together) with SCSI cables. The first and last physical SCSI devices connected on the ends of the SCSI bus must have a set of resistors called terminators. All other SCSI devices on the bus must have their terminators removed or disabled.

NOTE

The A5150A host bus adapter is also on the SCSI bus. Termination of the host bus adapter is automatically enabled when it is connected to the end of the bus.

Low-voltage differential peripheral devices are usually terminated with external terminators; however, they are sometimes terminated with jumpers or with a switch on the peripheral. Refer to the peripheral device manual to identify the termination setting of each device and how to change it.

Auto Termination Information

Two versions of the A5150A SCSI PCI Host Bus Adapter (HBA) will be in the field beginning approximately January 2001, with the release of a new version of the HBA. The older HBA has part number A5150-60001 and the new HBA has part number A5150-60101. The new HBA (also known as the *jumperless A5150A*) does not contain pins and jumpers used for manually configuring auto termination. On the jumperless A5150A, the default power-on setting has auto termination enabled. If you have the older adapter (A5150-60001), do not change the position of the jumpers; leave them as they were when you received the HBA from Hewlett-Packard (open - *not* jumpered). Auto termination in both A5150A HBAs—the A5150-60001 and the A5150-60101—is now controlled through commands at the Boot Console Handler (BCH) prompt. To use the auto termination feature of both A5150A HBAs, you must have the correct version of the Processor Dependent Code (PDC) on your system. The correct PDC versions are shown in Table 2-3.

Table 2-3 **Auto Termination PDC Versions**

HP 9000 System	PDC Version
A400 and A500	40.20 or later
L-Class	39.40 or later
N-Class	39.41 or later

The A5150A is supported on the A400, A500, L-Class, and N-Class HP 9000 systems.

Bus Termination

The SCSI bus must be properly terminated. The first and last physical SCSI devices on the ends of the SCSI bus must be terminated either by physical terminators or auto termination. The terminators of all other SCSI devices on the bus must be removed or disabled. Note that the A5150A HBA is also on the bus. However, because the A5150A HBA contains an automatic termination feature, external terminators on the HBA are not usually required. (Terminators are not shipped with the A5150A; you can order them separately, if needed.) The A5150A provides automatic termination when a SCSI cable from a powered SCSI device (a peripheral or other HBA) is connected to either the internal or external connector of the A5150A. Some exceptions where external terminators *are* required are described in “When and How to Turn Off Auto Termination” on page 31.

The older A5150A HBA (A5150-60001) has two sets of pins that control enabling and disabling (defeating) the auto termination feature. The pins—labeled A_TERM and B_TERM—are at the end of the HBA that is opposite the bulkhead connectors. A_TERM controls the auto termination feature for channel A, and B_TERM controls the feature for channel B.

NOTE

The A5150A's auto termination feature *cannot* be set independently for the internal and external connectors of the HBA.

In the factory default configuration of the older A5150-60001 HBA, the pin sets are normally open (not shorted together by the jumper). In the open state, the A5150A automatically senses whether a cable from a powered SCSI device is attached, and automatically provides the proper termination (depending on whether a powered device is present or no powered device is present).

The HBA senses the presence of connections to powered devices by detecting the ground signal on pin 50 of the SCSI cable.

- If the HBA detects the ground signal on pin 50 of only the internal *or* only the external connector, then termination is automatically applied on the HBA.
- If the HBA detects the ground signal on pin 50 of *both* the internal *and* external connectors, termination is automatically removed at the HBA.
- If an A5150A with the auto termination feature enabled is connected to another device that uses the same method of auto-sensing (for example, another HBA), the auto termination feature will not work properly. In this case, disable the auto termination feature, as described in “When and How to Turn Off Auto Termination” on page 31.

Even though the A5150A provides automatic termination, the opposite end of the SCSI bus must still be properly terminated. If you need an external terminator for connecting directly to the A5150A HBA, the appropriate terminator is HP product number A5296A, “VHDCI LVD/SE terminator.” If you need an additional terminator for connecting to a peripheral on the end of the SCSI bus, order the appropriate terminator needed to attach to the peripheral. See the peripheral’s documentation for additional information.

When and How to Turn Off Auto Termination

Information about when and how you turn off auto termination for the A5150A is given below.

When To Turn Off Auto Termination

Some sample scenarios for when you must turn off auto termination are described below. Note that the internal connectors of the HBA are not usually used in any of the HP 9000 servers. So, these scenarios assume that nothing is connected to the internal connectors.

Scenario One

If peripheral devices are connected to the external connector and the HBA is at the end of the SCSI bus, you must terminate the last device on the bus. Termination is also required on the HBA. If you have not disabled the auto termination feature of the HBA as described in “How to Turn Off Auto Termination” on page 33, termination is automatically applied on the HBA.

Scenario Two

If peripheral devices are connected to the external connector, and you have disabled the auto termination feature of the HBA by moving the jumpers to the position that shorts both pins of the pin sets together, you must put a separate terminator on the HBA. You can do this by connecting a terminator to the unused internal connector of the HBA, or by connecting an inline-terminated cable to the HBA.

NOTE

This is true only if the HBA is at the end of the SCSI bus, and not in the middle of the bus in a High Availability or multi-initiator configuration.

Scenario Three

If no devices are connected to the external connector and you have disabled auto termination as described in “How to Turn Off Auto Termination” on page 33, you must put a separate terminator on the external connector of the HBA. Be sure to use the proper type of terminator (LVD/SE for the A5150A).

Scenario Four

If peripheral devices are connected to the external connector via a V-cable and the HBA is in the middle of the SCSI bus, you must terminate the last device on the bus. In this configuration, auto termination must be disabled on the HBA to prevent improper termination of the bus.

Scenario Five

If the HBA is connected to another HBA in a multi-initiator or High Availability configuration, you must disable the auto termination feature as described in “How to Turn Off Auto Termination” on page 33.

Scenario Six

The HBA is not able to distinguish inline-terminated cables from regular SCSI cables. If an inline-terminated cable is connected to an HBA that has auto termination enabled, termination will be provided by both the cable and the HBA. This would result in improper (double) termination of the SCSI bus. To prevent this, disable auto termination any time inline-terminated cables are connected to the HBA.

Scenario Seven

V-Class systems use cables with inline termination. So, the jumpers of any HBAs installed in a V-Class system are set to disable auto termination when they are shipped from Hewlett-Packard.

Scenario Eight

High Availability configurations use inline-terminated cables exclusively, so you must disable auto termination on any HBAs used in an HA environment.

How to Turn Off Auto Termination

You control the auto termination feature through commands at the BCH prompt. See the steps below.

NOTE

The following steps and examples are specific to N-Class systems. Menus, commands, and responses will be slightly different on other systems.

To change the auto termination state of an A5150A HBA, follow these steps:

Installing the A5150A Adapter
SCSI Bus Termination

Step 1. Check the PDC version, by booting the system to the BCH prompt and then doing the following:

- a. At the Main Menu, type **in** (for Information Menu).
- b. At the Information Menu, type **fv** (to display the firmware version).
The output could look like this:

```
FIRMWARE INFORMATION
```

```
Firmware Version:          39.41
```

Table 2-3, earlier in this document, shows the required PDC versions for using auto termination on each HP 9000 system. If you do not have a correct PDC version on your system, contact your HP support representative.

Step 2. Determine the HBA's path by doing the following:

- a. If already at the Main Menu, type **in** (for Information Menu); go to step b.

If not already at the Main Menu, type **main** (to return to the Main Menu), type **in** (for Information Menu), then go to step b.

- b. At the Information Menu, type **io** (to display I/O interface information). The output could look like this:

```
PCI DEVICE INFORMATION
```

Description	Path (dec)	Vendor ID	Device ID	Bus #	Slot #
SCSI bus cntrl	0/2/0/0	0x1000	0xb	16	6

In this example, the HBA's path is **0/2/0/0** (shown in **bold**, for emphasis, in the listing above).

Step 3. Change the HBA's auto termination state by doing the following:

- a. If already at the Main Menu, type **ser** (for Service Menu); go to step b.

If not already at the Main Menu, type **main** (to return to the Main Menu), type **ser** (for Service Menu), then go to step b.

- b. In the Service Menu, type `scsi` (to display the current status of SCSI devices). The output could look like this:

Path (dec)	Initiator ID	SCSI Rate	Auto Term
-----	-----	-----	-----
.	.	.	.
0/2/0/0	7	Fast	Off

In this example, the HBA's auto termination state is Off (shown in **bold**, for emphasis, in the listing above).

- c. Still in the Service Menu, type the following command:

```
scsi term path state
```

where *path* is the HBA's path and *state* is what you want to set the HBA's auto termination state to. So, using the information for the HBA in the two examples above, you would type

```
scsi term 0/2/0/0 on
```

to change the HBA's auto termination state to `on`.

If you want to be sure the auto termination state changed, you can repeat step b to display the SCSI device status.

Setting SCSI IDs

You must set each SCSI device and the host adapter to a separate SCSI ID (0 through 15 for a 16-bit SCSI). SCSI ID 7 is the preset host adapter setting, giving it the highest priority on the SCSI bus. If you plan to boot your computer from a hard disk drive on the SCSI bus, that drive should be set to SCSI ID 6 or the lowest SCSI ID on the bus.

To change this default to a different SCSI address for HA applications, you must use the Boot Console Handler or BCH for N-4000 systems. There are no SCSI address switches or jumpers. You must invoke the appropriate commands in the SCSI section of the BCH and change the address electronically to whatever is required for the HA configuration being used. Refer to "Checking SCSI Bus Compatibility" on page 42 for more information.

SCSI Bus Termination

The peripheral device SCSI IDs are usually set with jumpers or a switch on the peripheral. Refer to the peripheral manufacturer's instructions to determine the ID of each device and how to change it (via BCH for N-Class systems). You must have no duplication of SCSI IDs on a SCSI bus.

- Step 1.** Determine the SCSI ID required for each device on the SCSI bus.
- Step 2.** Make any necessary changes to the SCSI IDs and record the IDs for future reference. You may use the following table.

Table 2-4**Record of SCSI IDs**

SCSI ID	SCSI Device Channel A	SCSI Device Channel B
15		
14		
13		
12		
11		
10		
9		
8		
7	Adapter (default)	Adapter (default)
6		
5		
4		
3		
2		
1		
0		

Verifying Installation

After installing the adapter and attaching peripheral devices, verify that all components are working. Refer to your system documentation for information on verifying operation.

HP 9000

- Step 1.** To verify that the adapter is correctly installed, execute the following command:

```
ioscan -f
```

The `ioscan` output could look like this:

```
ext_bus 0 0/0/0 c720 CLAIMED INTERFACE Ultra 2 wide SCSI
```

The third column represents the hardware path of the slot the adapter is installed in. For information about the `ioscan` command, refer to your operating system reference manual or the `ioscan` man page.

- Step 2.** Verify that the adapter and driver display.
- Step 3.** Verify that the devices you attached to the adapter display.

Installing the A5150A Adapter
Verifying Installation

HP e3000

Assume an N-Class system with an I/O card being added to slot #12, we will expect paths 1/0/0/0 and 1/0/0/1 to be returned for our card.

Step 1. From BCH menus:

```

-----
-Command          Description
-----
ALL              Display all system information
...
  IO            Display I/O interface information
...
-----
Information Menu: Enter command > io

I/O MODULE INFORMATION

          Path  Slot
          (dec) Number  HVERSION  SVERSION  Vers
-----
System bus adapter  0
Local bus adapter  0/0  Built_In  0x7820  0xa00  0x0
Local bus adapter
...
Local bus adapter  1/0  12      0x7820  0xa00  0x0
...
PCI DEVICE INFORMATION

          Path          Vendor  Device  Bus  Slot
          (dec)         Id      Id      #   #
-----
Ethernet cntlr    0/0/0/0    0x1011  0x19    0   Built_In
SCSI bus cntlr    0/0/1/0    0x1000  0xc     0   Built_In
SCSI bus cntlr    0/0/2/0    0x1000  0xf     0   Built_In
SCSI bus cntlr    0/0/2/1    0x1000  0xf     0   Built_In
Comp. ser cntlr   0/0/4/0    0x103c  0x1048  0   Built_In
Comp. ser cntlr   0/0/5/0    0x103c  0x1048  0   Built_In
SCSI bus cntlr    1/0/0/0    0x1000  0xf     128  12
SCSI bus cntlr    1/0/0/1    0x1000  0xb     128  12
Information Menu: Enter command >main
Main Menu: Enter command or menu > sea 1/0/0/0
Searching for potential boot device(s) - on Path 1/0/0/0

This may take several minutes.
To discontinue search, press any key (termination may not be immediate).
  Path#  Device Path (dec)  Device Path (mnem)  Device Type
-----
  P0     1/0/0/0.6           intscsia.6          Random access media
Main Menu: Enter command or menu >

```

3

Troubleshooting

The A5150A adapter is a single field-replaceable unit (FRU) and does not contain any field-serviceable parts. Troubleshooting procedures described in this chapter are limited to verifying that the adapter is operational and that a valid connection is established.

This chapter contains the following sections that describe how to troubleshoot the A5150A adapter:

- “General Procedure” on page 41.
- “Checking SCSI Bus Compatibility” on page 42.
- “Using Support Tools Manager (STM)” on page 47.
- “Contacting Your Hewlett-Packard Representative” on page 48.

General Procedure

The A5150A adapter is a single field-replaceable unit (FRU) and does not contain any field-serviceable parts. Troubleshooting procedures described in this section are limited to verifying that the adapter is operational and a valid connection is established.

In general, follow these steps to troubleshoot the A5150A adapter:

Step 1. Check the connection.

Make sure that the correct cable is used, connected, and operating properly and that there are no bent pins in any of the connectors.

Step 2. Check SCSI bus compatibility.

Ensure transfer rate compatibility with the attached devices using the SCSI boot menu command.

Step 3. Check the adapter.

Inspect the adapter to make sure it is seated properly in the PCI bus slot. If necessary, power down the system, reseal the adapter, and restart the system.

Step 4. Run diagnostics.

If a visual inspection of the adapter and cable does not reveal any problems, or if an action taken as a result of the inspection does not produce a working adapter, you may want to run diagnostics to determine whether the adapter can communicate and respond to PCI bus instructions. Diagnostics are described in the next section.

If diagnostics determine that the adapter is defective, you must replace it. Contact your local Hewlett-Packard customer representative or call the HP Response Center.

Checking SCSI Bus Compatibility

You can ensure SCSI controller and SCSI device compatibility by using the `SCSI` command to display and select SCSI bus parameters.

The `SCSI` command is available from the boot menu displayed after the test station has booted (if autoboot is disabled). The boot menu looks like this (for highlighting reasons, the `SCSI` command is in bold here):

Command	Description
-----	-----
AUTO [BOOT SEARCH ON OFF]	Display or set the specified flag
BOOT [PRI ALT <path> <args>]	Boot from a specified path
BOOTimer [time]	Display or set boot delay time
CLEARPIM	Clear PIM storage
CPUconfig [<proc>] [ON OFF]	Configure/Deconfigure Processor
Default	Set the system to defined values
Display	Display this menu
ForthMode	Switch to the Forth OBP interface
IO	List the I/O devices in the system
LS [<path> flash]	List the boot or flash volume
OS [hpux sppux]	Display/Select Operating System
PASSword	Set the Forth password
Path [PRI ALT CON] [<path>]	Display or modify a path
PDT [CLEAR DEBUG]	Display/clear Non-Volatile PDT state
PIM_info [cpu#] [HPMC TOC LPMC]	Display PIM of current or any CPU
RESET [hard debug]	Force a reset of the system
RESTRict [ON OFF]	Display/Select restricted access to Forth
SCSI [INIT RATE] [bus slot val]	List/Set SCSI controller parms
SEARCH [<path>]	Search for boot devices
SECure [ON OFF]	Display or set secure boot mode
TIme [cn:yr:mo:dy:hr:mn[:ss]]	Display or set the real-time clock
VERsion	Display the firmware versions

The SCSI Command

As explained above, you can use the `SCSI` command to check the compatibility of the SCSI adapter and the SCSI device(s), by displaying and setting SCSI bus parameters.

Displaying Transfer Rates

To use the `SCSI` command to display the SCSI transfer rate for an adapter, follow this syntax:

```
SCSI rate bus_number slot_number
```

where

bus_number Specifies the number of the bus the adapter is installed on.

slot_number Specifies the number of the slot the adapter is in.

For example:

- To display the SCSI transfer rate for the adapter installed on bus 5 slot 2, issue this command:

```
SCSI rate 5 2
```

The output could look something like this:

```
PCI device /5.2 = no limit
```

- To list transfer rates for all bus and slot numbers, issue this command:

```
SCSI rate
```

Setting Transfer Rates

To use the SCSI command to set the SCSI transfer rate for an adapter, follow this syntax:

```
SCSI rate bus_number slot_number rate
```

where

- | | |
|--------------------|--|
| <i>bus_number</i> | Specifies the number of the bus the adapter is installed on. |
| <i>slot_number</i> | Specifies the number of the slot the adapter is in. |
| <i>rate</i> | Specifies the adapter's transfer rate: <ul style="list-style-type: none">• 0 (no limit)• 10 (Fast SCSI)• 20 (Ultra SCSI) |

For example, to set the SCSI transfer rate for the adapter installed on bus 5 slot 2 to Fast SCSI and then display the results, issue these commands:

```
SCSI rate 5 2 10
```

```
SCSI rate 5 2
```

The output (of the second command) could look something like this:

```
PCI device /5.2 = fast SCSI
```

Displaying SCSI IDs

To use the SCSI command to display the initiator (SCSI) IDs for an adapter, follow this syntax:

```
SCSI init bus_number slot_number
```

where

bus_number Specifies the number of the bus the adapter is installed on.

slot_number Specifies the number of the slot the adapter is in.

For example:

- To display the SCSI ID for the adapter on bus 5 slot 2, issue this command:

```
SCSI init 5 2
```

The output could look something like this:

```
PCI device /5.2 = 7
```

- To list the SCSI IDs for all bus and slot numbers, issue this command:

```
SCSI init
```

Setting SCSI IDs

To use the SCSI command to set the initiator (SCSI) ID for an adapter, follow this syntax:

```
SCSI init bus_number slot_number ID_number
```

where

bus_number Specifies the number of the bus the adapter is installed on.

slot_number Specifies the number of the slot the adapter is in.

ID_num Specifies the adapter's SCSI ID number.

For example, to set the SCSI ID for the adapter installed on bus 5 slot 2 to 6 and then display the results, issue these commands:

```
SCSI init 5 2 6
```

```
SCSI init 5 2
```

The output (of the second command) could look something like this:

```
PCI device /5.2 = 6
```

Using Support Tools Manager (STM)

STM is a software application that can be run from the console to obtain status and descriptive information about the A5150A adapter, diagnose problems, and update firmware. See the *Support Tools Manager User's Guide* for more details about STM.

Contacting Your Hewlett-Packard Representative

If the equipment is covered by an HP service contract, document the problem as a service request and forward it to your HP representative. Include the following information where applicable:

- Describe the problem, including the events and symptoms leading up to the problem. Attempt to describe the source of the problem.

Include commands, communication subsystem commands, functionality of user programs, result codes and messages, and data that can reproduce the problem.

- Obtain the version, update, and fix information for all software.

1. To check the version of the kernel, enter this command:

```
uname -r
```

To check patches, enter:

```
what /stand/vmunix | grep scsi
```

2. To check the version of MPE/iX enter: SHOWME

To check patches, enter: PRINT HPSWINF0.PUB.SYS

This allows HP to determine if the problem is already known and the correct software is installed at your site.

- Illustrate as clearly as possible the context of any messages. Record all error messages and numbers that appear at the user terminal and the system console.
- Prepare the formatted output and a copy of the log file for the HP representative to analyze.
- Prepare a listing of the HP-UX or MPE/iX I/O configuration being used for the HP representative to analyze.
- Try to determine the general area within the software where the problem may exist. Refer to the appropriate reference manual and follow the guidelines on gathering information for that product.
- Document your interim (workaround) solution. The cause of the problem can sometimes be found by comparing the circumstances in

which the problem occurs with the circumstances in which the problem does not occur.

- In the event of a system failure, obtain a full memory dump.
- For HP-UX: If the directory `/var/adm/crash` exists, the HP-UX utility `/sbin/savecore` automatically executes during reboot to save the memory dump. HP recommends that you create the `/tmp/syscore` directory after successfully installing this product. Send the output of the system failure memory dump to the HP representative.
- For MPE/iX: If you use AUTORESTART and DUMPTODISK products follow your normal system recovery steps. Otherwise take a memory dump and save the resulting tape. Contact HP Support for analysis of your failure.

If the equipment is not covered by an HP service contract, there may be a charge for time and materials.

Troubleshooting
Contacting Your Hewlett-Packard Representative

A **SCSI Sense Codes**

This appendix shows the possible codes that appear in SCSI error messages.

The following example shows a typical SCSI error message:

```
[+6708 72410001 002a9858 0:7] scsi disk: CHECK CONDITION on disk 0:6:5:0
Read of logical block 509856, count 128
disk sd45a, block 254920, 65536 bytes
Valid = 1, Error code = 0x70
Segment number = 0x00, Filemark = 0, EOM = 0, ILI = 0
Sense key = 0x1, "RECOVERED ERROR"
Information = 0x00 0x07 0xc7 0xe4
[+6709 72410001 002a9a10 0:7] scsi disk:      Additional sense length = 0x0a
Command-specific information = 0x00 0x00 0x00 0x00
Additional sense = 0x18, Qualifier = 0x01
Field replaceable unit code = 0xea
SKSV = 1, C/D = 0, BPV = 0, Bit pointer = 0
Field pointer = 0x0003
```

The status (**CHECK CONDITION**) and sense key (**RECOVERED ERROR**)—shown in bold in the example above—are interpreted for you in the error message text. Each Additional sense and its corresponding Qualifier code—shown in bold in the example above—require interpretation on your part. Use the two codes together to determine the meaning. In the example above, the Additional sense (0x18) and Qualifier (0x01) codes together mean “recovered data with error correction and retries applied.” You can look up the various codes and keys in the tables on the next pages.

Table A-1 below lists all possible SCSI status codes and their meanings.

Table A-1 **SCSI Status Codes**

SCSI Status Code	Meaning
0x00	Good
0x02	Check condition
0x04	Condition met
0x08	Busy
0x10	Intermediate
0x14	Intermediate—condition met
0x18	Reservation conflict
0x22	Command terminated
0x28	Queue full

Table A-2 below lists all possible SCSI sense keys and their meanings.

Table A-2 SCSI Sense Keys

SCSI Sense Key	Meaning
0	No sense
0x1	Recovered error
0x2	Not ready
0x3	Medium error
0x4	Hardware error
0x5	Illegal request
0x6	Unit attention
0x7	Data protect
0x8	Blank check
0x9	Vendor-specific
0xa	Copy aborted
0xb	Aborted command
0xc	Equal
0xd	Volume overflow
0xe	Miscompare
0xf	Reserved

Table A-3 below lists the Additional sense codes and Qualifier codes and their meanings. Remember that you must use the combined codes—an Additional sense code/Qualifier code pair—to find the correct meaning.

Table A-3**SCSI Additional Sense Code/Qualifier Code Pairs**

SCSI Additional Sense Code	SCSI Qualifier Code	Meaning
0x00	0x00	No additional sense information
	0x01	Filemark detected
	0x02	End-of-partitions/medium detected
	0x03	Setmark detected
	0x04	Beginning of partition/medium detected
	0x05	End-of-data detected
	0x06	I/O process terminated
	0x11	Audio play operation in progress
	0x12	Audio play operation paused
	0x13	Audio play operation successfully completed
	0x14	Audio play operation stopped due to error
	0x15	No current audio status to return
0x01	0x00	No index/sector signal
0x02	0x00	No seek complete
0x03	0x00	Peripheral device write fault
	0x01	No write current
	0x02	Excessive write errors

Table A-3 SCSI Additional Sense Code/Qualifier Code Pairs (Continued)

SCSI Additional Sense Code	SCSI Qualifier Code	Meaning
0x04	0x00	Logical unit not ready, cause not reportable
	0x01	Logical unit in process of becoming ready
	0x02	Logical unit not ready, initializing command required
	0x03	Logical unit not ready, manual intervention required
	0x04	Logical unit not ready, format in progress
0x05	0x00	Logical unit does not respond to selection
0x06	0x00	Reference position found
0x07	0x00	Multiple peripheral devices selected
0x08	0x00	Logical unit communication failure
	0x01	Logical unit communication time-out
	0x02	Logical unit communication parity error
0x09	0x00	Track following error
	0x01	Tracking servo failure
	0x02	Focus servo failure
	0x03	Spindle servo failure
0x0a	0x00	Error log overflow
0x0c	0x00	Write error
	0x01	Write error recovered with auto reallocation
	0x02	Write error—auto reallocation failed

Table A-3 SCSI Additional Sense Code/Qualifier Code Pairs (Continued)

SCSI Additional Sense Code	SCSI Qualifier Code	Meaning
0x10	0x00	ID crc or ecc error
0x11	0x00	Unrecovered read error
	0x01	Read retries exhausted
	0x02	Error too long to correct
	0x03	Multiple read errors
	0x04	Unrecovered read error—auto reallocate failed
	0x05	l-ec uncorrectable error
	0x06	circ unrecovered error
	0x07	Data resynchronization error
	0x08	Incomplete block read
	0x09	No gap found
	0x0a	Miscorrected error
	0x0b	Unrecovered read error—recommend reassignment
	0x0c	Unrecovered read error—recommend rewrite the data
0x12	0x00	Address mark not found for ID field
0x13	0x00	Address mark not found for data field

Table A-3 SCSI Additional Sense Code/Qualifier Code Pairs (Continued)

SCSI Additional Sense Code	SCSI Qualifier Code	Meaning
0x14	0x00	Recorded entity not found
	0x01	Record not found
	0x02	Filemark or setmark not found
	0x03	End-of-data not found
	0x04	Block sequence error
0x15	0x00	Random positioning error
	0x01	Mechanical positioning error
	0x02	Positioning error detected by read of medium
0x16	0x00	Data synchronization mark error
0x17	0x00	Recovered data with no error correction applied
	0x01	Recovered data with retries
	0x02	Recovered data with positive head offset
	0x03	Recovered data with negative head offset
	0x04	Recovered data with retries and/or circ applied
	0x05	Recovered data using previous sector ID
	0x06	Recovered data without ecc—data auto-reallocated
	0x07	Recovered data without ecc—recommend reassignment
	0x08	Recovered data without ecc—recommend rewrite

Table A-3 SCSI Additional Sense Code/Qualifier Code Pairs (Continued)

SCSI Additional Sense Code	SCSI Qualifier Code	Meaning
0x18	0x00	Recovered data with error correction applied
	0x01	Recovered data with error correction and retries applied
	0x02	Recovered data—data auto-reallocated
	0x03	Recovered data with circ
	0x04	Recovered data with lec
	0x05	Recovered data—recommend reassignment
	0x06	Recovered data—recommend rewrite
0x19	0x00	Defect list error
	0x01	Defect list not available
	0x02	Defect list error in primary list
	0x03	Defect list error in grown list
0x1a	0x00	Parameter list length error
0x1b	0x00	Synchronous data transfer error
0x1c	0x00	Defect list not found
	0x01	Primary defect list not found
	0x02	Grown defect list not found
0x1d	0x00	Miscompare during verify operation
0x1e	0x00	Recovered ID with ecc
0x20	0x00	Invalid command operation code

Table A-3 SCSI Additional Sense Code/Qualifier Code Pairs (Continued)

SCSI Additional Sense Code	SCSI Qualifier Code	Meaning
0x21	0x00	Logical block address out of range
	0x01	Invalid element address
0x22	0x00	Illegal function
0x24	0x00	Invalid field in cdb
0x25	0x00	Logical unit not supported
0x26	0x00	Invalid field in parameter list
	0x01	Parameter not supported
	0x02	Parameter value invalid
	0x03	Threshold parameters not supported
0x27	0x00	Write protected
0x28	0x00	Not ready to ready transition (medium may have changed)
	0x01	Import or export element assessed
0x29	0x00	Power on, reset, or bus device reset occurred
0x2a	0x00	Parameters changed
	0x01	Mode parameters changed
	0x02	Log parameters changed
0x2b	0x00	Copy cannot execute since host cannot disconnect
0x2c	0x00	Command sequence error
	0x01	Too many windows specified

Table A-3 SCSI Additional Sense Code/Qualifier Code Pairs (Continued)

SCSI Additional Sense Code	SCSI Qualifier Code	Meaning
0x2f	0x00	Commands cleared by another initiator
0x30	0x00	Incompatible medium installed
	0x01	Cannot read medium—unknown format
	0x02	Cannot read medium—incompatible format
	0x03	Cleaning cartridge installed
0x31	0x00	Medium format corrupted
0x32	0x00	No defect spare location available
	0x01	Defect list update failure
0x33	0x00	Tape length error
0x36	0x00	Ribbon, ink, or tower failure
0x37	0x00	Rounded parameter
0x39	0x00	Saving parameters not supported
0x3a	0x00	Medium not present

Table A-3 SCSI Additional Sense Code/Qualifier Code Pairs (Continued)

SCSI Additional Sense Code	SCSI Qualifier Code	Meaning
0x3b	0x00	Sequential positioning error
	0x01	Tape position error at beginning-of-medium
	0x02	Tape position error at end-of-medium
	0x03	Tape or electronic vertical forms unit not ready
	0x04	Slew failure
	0x05	Paper jam
	0x06	Failed to sense top-of-form
	0x07	Failed to sense bottom-of-form
	0x08	Reposition error
	0x09	Read past end of medium
	0x0a	Read past beginning of medium
	0x0b	Position past end of medium
	0x0c	Position past beginning of medium
	0x0d	Medium destination element full
0x0e	Medium source element empty	
0x3d	0x00	Invalid bits in identify message
0x3e	0x00	Logical unit has not self-configured yet

Table A-3 SCSI Additional Sense Code/Qualifier Code Pairs (Continued)

SCSI Additional Sense Code	SCSI Qualifier Code	Meaning
0x3f	0x00	Target operation conditions have changed
	0x01	Microcode has been changed
	0x02	Changed operating definition
	0x03	Inquiry data has changed
0x40	0x00	RAM failure
	<i>nn</i>	Diagnostic failure on component <i>nn</i>
0x41	0x00	Data path failure
0x42	0x00	Power-on or self-test failure
0x43	0x00	Message error
0x44	0x00	Internal target failure
0x45	0x00	Select or reselect failure
0x46	0x00	Unsuccessful soft reset
0x47	0x00	SCSI parity error
0x48	0x00	Initiator detected error message received
0x49	0x00	Invalid message error
0x4a	0x00	Command phase error
0x4b	0x00	Data phase error
0x4c	0x00	Logical unit failed self-configuration
0x4e	0x00	Overlapped commands attempted

Table A-3 SCSI Additional Sense Code/Qualifier Code Pairs (Continued)

SCSI Additional Sense Code	SCSI Qualifier Code	Meaning
0x50	0x00	Write append error
	0x01	Write append position error
	0x02	Position error related to timing
0x51	0x00	Erase failure
0x52	0x00	Cartridge fault
0x53	0x00	Media load or eject failed
	0x01	Unload tape failure
	0x02	Medium removal prevented
0x54	0x00	SCSI to host system interface failure
0x55	0x00	System resource failure
0x56	0x00	Reserved
0x57	0x00	Unable to recover table of contents
0x58	0x00	Generation does not exist
0x59	0x00	Updated block read
0x5A	0x00	Operator request or state change input (unspecified)
	0x01	Operator medium removal request
	0x02	Operator selected write protect
	0x02	Operator selected write permit

Table A-3 SCSI Additional Sense Code/Qualifier Code Pairs (Continued)

SCSI Additional Sense Code	SCSI Qualifier Code	Meaning
0x5B	0x00	Log exception
	0x01	Threshold condition met
	0x02	Log counter at maximum
	0x03	Log list codes exhausted
0x5C	0x00	RPL status change
	0x01	Spindles synchronized
	0x02	Spindles not synchronized
0x5D	0x00	Reserved
0x5E	0x00	Reserved
0x5F	0x00	Reserved
0x60	0x00	Lamp failure
0x61	0x00	Video acquisition error
	0x01	Unable to acquire video
	0x02	Out of focus
0x62	0x00	Scan head positioning error
0x63	0x00	End of user area encountered on this track
0x64	0x00	Illegal mode for this track
0x65	0x00	Reserved
0x66	0x00	Reserved
0x67	0x00	Reserved
0x68	0x00	Reserved

Table A-3**SCSI Additional Sense Code/Qualifier Code Pairs (Continued)**

SCSI Additional Sense Code	SCSI Qualifier Code	Meaning
0x69	0x00	Reserved
0x6A	0x00	Reserved
0x6B	0x00	Reserved
0x6C	0x00	Reserved
0x6D	0x00	Reserved
0x6E	0x00	Reserved
0x6F	0x00	Reserved

B **Regulatory Information**

This appendix contains all of the regulatory-related information for the A5150A adapter.

Regulatory Statements

This section contains all of the regulatory statements for the A5150A adapter.

FCC Statement (For U.S.A. Only)

The Federal Communications Commission (in 47 CFR 15.105) has specified that the following notice be brought to the attention of the users of this product.

This equipment has been tested and found to comply with the limits for a Class A digital device, pursuant to Part 15 of the FCC Rules. These limits are designed to provide reasonable protection against harmful interference when the equipment is operated in a commercial environment. This equipment generates, uses, and can radiate radio frequency energy and, if not installed and used in accordance with the instruction manual, may cause harmful interference to radio communications. Operation of this equipment in a residential area is likely to cause harmful interference in which case the user will be required to correct the interference at his own expense. The end user of this product should be aware that any changes or modifications made to this equipment without the approval of Hewlett-Packard could result in the product not meeting the Class A limits, in which case the FCC could void the user's authority to operate the equipment.

IEC Statement (Worldwide)

This is a Class A product. In a domestic environment this product may cause radio interference in which case the user may be required to take adequate measures.

DOC Statement (Canada)

This Class A digital apparatus meets all requirements of the Canadian interference-Causing Equipment Regulations.

Cet appareil numérique de la classe A respecte toutes les exigences du Règlement sur le matériel brouilleur du Canada.

Spécification ATI Classe A (France)

DECLARATION D'INSTALLATION ET DE MISE EN EXPLOITATION d'un matériel de traitement de l'information (ATI), classé A en fonction des niveaux de perturbations radioélectriques émis, définis dans la norme européenne EN 55022 concernant la Compatibilité Electromagnétique.

Cher Client,

Conformément à la Réglementation Française en vigueur l'installation ou le transfert d'installation, et l'exploitation de cet appareil de classe A, doivent faire l'objet d'une déclaration (en deux exemplaires) simultanément auprès des services suivants:

- Comité de Coordination des Télécommunications 20, avenue de Ségur
- 75700 PARIS
- Préfecture du département du lieu d'exploitation

Le formulaire à utiliser est disponible auprès des préfetures.

La déclaration doit être faite dans les 30 jours suivant la mise en exploitation.

Le non respect de cette obligation peut être sanctionné par les peines prévues au code des Postes et Télécommunications et celles indiquées dans la loi du 31 mai 1993 susvisée.

Arrêté du 27 Mars 1993, publié au J.O. du 28 Mars - ATI

VCCI Statement (Japan)

この装置は、情報処理装置等電波障害自主規制協議会（VCCI）の基準に基づくクラスA情報技術装置です。この装置を家庭環境で使用すると電波妨害を引き起こすことがあります。この場合には使用者が適切な対策を講ずるよう要求されることがあります。

Declaration of Conformity

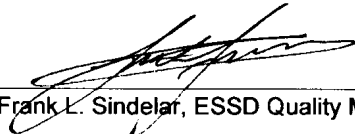
DECLARATION OF CONFORMITY according to ISO/IEC Guide 22 and EN 45014	
Manufacturer's Name:	Hewlett-Packard Company Enterprise Storage Solutions Division
Manufacturer's Address:	8000 Foothills Blvd. Roseville, CA 95747 USA
declares, that the product	
Product Name:	Dual Port Ultra 2 SCSI HBA
Model Number(s):	A5150A
Product Options:	N/A
conforms to the following Product Specifications:	
Safety:	IEC 950:1991 + A1, A2, A3, A4 / EN 60950:1992 + A1, A2, A3, A4 GB 4943-1995
EMC:	CISPR 22:1993 / EN 55022:1994 - Class A ¹ GB 9254-1988 EN 50082-1:1992 IEC 801-2:1991 / prEN 55024-2:1992, 4 kV CD, 8 kV AD IEC 801-3:1984 / prEN 55024-3:1991, 3 V/m IEC 801-4:1988 / prEN 55024-4:1993, 0.5 kV Signal Lines 1 kV Power Lines
Supplementary Information:	
The product herewith complies with the requirements of the EMC Directive 89/336/EEC and carries the CE marking accordingly.	
1) The Product was tested in a typical configuration with HP 9000 computer system.	
Roseville, 10/6/98	 Frank L. Sindelar, ESSD Quality Mgr.
European Contact: Your local Hewlett-Packard Sales and Service Office or Hewlett-Packard GmbH, Department HQ-TRE, Herrenberger Straße 130, D-71034 Böblingen (FAX: + 49-7031-14-3143)	

Glossary

A

address A specific location in memory, designated either numerically or by a symbolic name.

Asynchronous Data Transfer

One of the ways data is transferred over the SCSI bus. It is slower than synchronous data transfer.

BIOS (Basic Input/Output System) Software that provides basic read/write capability. Usually kept as firmware (ROM based). The system BIOS on the main board of a computer is used to boot and control the system. The SCSI BIOS on the host adapter acts as an extension of the system BIOS.

bit A binary digit. The smallest unit of information a computer uses. The value of a bit (0 or 1) represents a two-way choice, such as on or off, true or false.

bus A collection of wires in a cable or copper traces on a circuit board used to transmit data, status, and control signals. EISA, PCI, and SCSI are examples of buses.

bus mastering A high-performance way to transfer data. The host adapter controls the transfer of data directly to and from system memory without bothering the computer's

microprocessor. This is the fastest way for multi-tasking operating systems to transfer data.

byte A unit of information consisting of eight bits.

chain A topology in which every device is connected to two others, except for two-end devices that are connected to only one other.

CISPR (Committee, International and Special, for Protection in Radio) An international committee on radio frequency interference.

configuration Refers to the way a computer is set up; the combined hardware components (computer, monitor, key board, and peripheral devices) that make up a computer system; or the software settings that allow the hardware components to communicate with each other.

CPU (central processing unit)

The "brain" of the computer that performs the actual computations. The term Micro Processor Unit (MPU) is also used.

DMA (direct memory access) A method of moving data from a storage device directly to RAM, without using the CPU's resources.

DMA bus master A feature that allows a peripheral to control the

flow of data to and from system memory by blocks, as opposed to PIO (Programmed I/O) where the flow is byte by byte.

device driver A program that allows a microprocessor (through the operating system) to direct the operation of a peripheral device.

differential A hardware configuration for connecting SCSI devices. It uses a pair of lines for each signal transfer (as opposed to single-ended SCSI which references each SCSI signal to a common ground).

EEPROM (electronically erasable programmable read-only memory) A memory chip typically used to store configuration information. See NVRAM.

EISA (Extended Industry Standard Architecture) An extension of the 16-bit ISA bus standard. It allows devices to perform 32-bit data transfers.

external SCSI device A SCSI device installed outside the computer cabinet. External SCSI devices are connected in a chain using shielded cables.

Fast SCSI A standard for SCSI data transfers. It allows a transfer rate of up to 10 MBytes/sec over an 8-bit SCSI bus, and up to 20 MBytes/sec over a 16-bit SCSI bus.

FCC Federal Communications Commission.

file A named collection of information, usually stored on a disk.

firmware Software that is permanently stored in ROM. In the case of BIOS, it can be accessed during boot time without the aid of an operating or file system.

hard disk A rigid disk permanently sealed into a drive cartridge. A hard disk can store very large amounts of information.

host The computer system in which a SCSI host adapter is installed. It uses the SCSI host adapter to transfer information to and from devices attached to the SCSI bus.

host bus adapter (HBA) A circuit board and/or integrated circuit device that provides a SCSI bus connection to the computer system.

internal SCSI device A SCSI device installed inside the computer cabinet. These devices are connected in a chain using an unshielded ribbon cable.

IRQ (interrupt request channel) A path through which a device can get the immediate attention of the computer's CPU. The PCI bus assigns an IRQ path

for each SCSI host adapter.

ISA (Industry Standard Architecture) A type of computer bus used in most PCs. It allows devices to send and receive data 16 bits at a time.

KByte (kilobyte) A measure of computer storage equal to 1024 bytes.

local bus A way to connect peripherals directly to the computer processor's data path. It bypasses the slower ISA and EISA buses. PCI is a local bus standard.

logical unit A subdivision, either logical or physical, of a SCSI device. Most devices have only one logical unit, but up to sixteen are allowed for a 16-bit SCSI bus and eight for an 8-bit SCSI bus.

LUN (logical unit number) An encoded three-bit number for the logical unit.

LVD (low-voltage differential)

A robust design methodology that improves power consumption, data integrity, cable lengths, and support for multiple devices while providing a migration path for increased I/O performance.

MByte (megabyte) A measure of computer storage equal to 1024 kilobytes.

mainboard A large circuit board

that holds RAM, ROM, the microprocessor, custom integrated circuits, and other components that make a computer work. It also has expansion slots for host adapters and other plug-in boards.

main memory The part of a computer's memory that is directly accessible by the CPU (usually synonymous with RAM).

motherboard See mainboard. In some countries, the term motherboard is not appropriate.

multi-tasking The initiation and control of more than one sequence of operations. This allows programs to operate in parallel.

multi-threading The simultaneous accessing of data by more than one SCSI device. This increases the aggregate data throughput.

NVRAM (Non-Volatile Random Access Memory) An EEPROM (Electrically Erasable Read Only Memory chip) used to store configuration information.

operating system A program that organizes the internal activities of the computer and its peripheral devices. An operating system performs basic tasks such as moving data to and from devices, and managing information in memory. It also provides the user interface.

parity checking A way to verify the accuracy of data transmitted over the SCSI bus. One bit in the transfer is used to make the sum of all the 1 bits either odd or even (for odd or even parity). If the sum is not correct, an error message appears. SCSI uses odd parity.

PCI (peripheral component interconnect) A local bus specification that allows connection of integrated peripheral controller components, peripheral add-in boards, and processor/memory systems. It bypasses the slower ISA and EISA busses.

peripheral devices A hardware device (such as a video monitor, disk drive, printer, or CD-ROM) used with a computer and under the computer's control. SCSI peripherals are controlled through a SCSI host adapter.

pin-1 orientation The alignment of pin 1 on a SCSI cable connector and the pin 1 position on the SCSI connector into which it is inserted. External SCSI cables are keyed to ensure proper alignment, but internal SCSI ribbon cables may not be.

PIO (programmed input/output) A way the CPU can transfer data to and from memory via the computer's I/O ports. PIO can be faster than DMA, but requires CPU time.

port address Also Port Number. The address through which commands are sent to a host adapter board. This address is assigned by the PCI bus.

port number See port address.

queue tags A way to keep track of multiple commands while allowing increased throughput on the SCSI bus.

RAM (Random Access Memory) Generally, the computer's primary working memory in which program instructions and data are stored and are accessible to the CPU. Information can be written to and read from RAM. The contents of RAM are lost when the computer is turned off.

RISC core Symbios SCSI chips contain a RISC (Reduced Instruction Set Computer) processor, programmed through microcode scripts.

ROM (Read-Only Memory)

Memory from which information can be read but not changed. The contents of ROM are not erased when the computer is turned off.

SCAM (SCSI Configured AutoMatically) A method to automatically allocate SCSI IDs via software when SCAM compliant SCSI devices are attached.

SCSI (small computer system interface) A specification for a high-performance peripheral bus and command set. The original standard is now referred to as SCSI-1.

SCSI-2 The current SCSI specification that adds features to the original SCSI-1 standard.

SCSI-3 The next SCSI specification, that adds features to the SCSI-2 standard.

SCSI bus A host adapter and one or more SCSI peripherals connected by cables in a linear chain configuration. The host adapter may exist anywhere on the chain, allowing connection of both internal and external SCSI devices. A system may have more than one SCSI bus by using multiple host adapters.

SCSI device Any device conforming to the SCSI standard that attaches to the SCSI bus by means of a SCSI cable. This includes SCSI host adapters and SCSI peripherals.

SCSI ID A unique identification for each SCSI device on the SCSI bus. Each SCSI bus has fifteen available SCSI IDs numbered 0 through 15 for Wide SCSI or 0-7 for 8-bit SCSI. The host adapter is assigned ID 7, which gives it priority to control the bus.

SDMS (SCSI Device Management System) A Symbios software product that manages SCSI system I/O.

single-ended SCSI A hardware specification for connecting SCSI devices. It references each SCSI signal to a common ground, as opposed to differential SCSI and low-voltage differential SCSI, which use a separate return for each signal.

synchronous data transfer

One of the ways data is transferred over the SCSI bus. Transfers are clocked with fixed-frequency pulses.

System BIOS Controls the low level POST (Power On Self Test) and basic operation of the CPU and computer system.

termination The electrical connection required at each end of the SCSI bus, composed of a set of resistors.

Ultra SCSI A standard for SCSI data transfers. It allows a transfer rate of up to 20 MBytes/sec over an 8-bit SCSI bus, and up to 40 MBytes/sec over a 16-bit SCSI bus. STA (SCSI Trade Association) supports using the term "Ultra SCSI" over the older term "Fast-20."

Ultra2 SCSI A standard for SCSI data transfers. It allows a transfer

rate of up to 40 MBytes/sec over an 8-bit SCSI bus, and up to 80 MBytes/sec over a 16-bit SCSI bus. STA (SCSI Trade Association) supports using the term "Ultra2 SCSI" over the older term "Fast-40."

VCCI Voluntary Control Council for Interference.

VHDCI Very High Density Cable Interconnect.

Wide SCSI A SCSI-2 feature allowing 16 or 32-bit transfers on the SCSI bus. This dramatically increases the transfer rate over the standard 8-bit SCSI bus.

Wide Ultra SCSI The SCSI Trade Association term for SCSI bus width 16 bits, SCSI bus speed maximum data rate 40 MBytes/sec.

Wide Ultra2 SCSI The SCSI Trade Association term for SCSI bus width 16 bits, SCSI bus speed maximum data rate 80 MBytes/sec.

Free Manuals Download Website

<http://myh66.com>

<http://usermanuals.us>

<http://www.somanuals.com>

<http://www.4manuals.cc>

<http://www.manual-lib.com>

<http://www.404manual.com>

<http://www.luxmanual.com>

<http://aubethermostatmanual.com>

Golf course search by state

<http://golfingnear.com>

Email search by domain

<http://emailbydomain.com>

Auto manuals search

<http://auto.somanuals.com>

TV manuals search

<http://tv.somanuals.com>