

# HP StorageWorks

## N1200-320 4Gb Network Storage Router user and service guide



AG314-96001

Part number: AG314-96001  
First edition: June 2006



**Legal and notice information**

© Copyright 2006 Hewlett-Packard Development Company, L.P.

Hewlett-Packard Company makes no warranty of any kind with regard to this material, including, but not limited to, the implied warranties of merchantability and fitness for a particular purpose. Hewlett-Packard shall not be liable for errors contained herein or for incidental or consequential damages in connection with the furnishing, performance, or use of this material.

This document contains proprietary information, which is protected by copyright. No part of this document may be photocopied, reproduced, or translated into another language without the prior written consent of Hewlett-Packard. The information is provided "as is" without warranty of any kind and is subject to change without notice. The only warranties for HP products and services are set forth in the express warranty statements accompanying such products and services. Nothing herein should be construed as constituting an additional warranty. HP shall not be liable for technical or editorial errors or omissions contained herein.

Adobe® and Acrobat® are trademarks of Adobe Systems Incorporated.

Intel and Itanium are trademarks or registered trademarks of Intel Corporation or its subsidiaries in the United States and other countries.

Microsoft, Windows, Windows NT, and Windows XP are U.S. registered trademarks of Microsoft Corporation.

Oracle® is a registered U.S. trademark of Oracle Corporation, Redwood City, California.

UNIX® is a registered trademark of The Open Group.

N1200-320 4Gb Network Storage Router user and service guide

# Contents

About this guide . . . . .	7
Intended audience . . . . .	7
Related documentation . . . . .	7
Document conventions and symbols . . . . .	7
HP technical support . . . . .	8
HP-authorized reseller. . . . .	8
Helpful web sites . . . . .	8
<b>1 Introduction . . . . .</b>	<b>9</b>
External features overview . . . . .	9
Operation indicators . . . . .	10
How the HP N1200-320 4Gb Network Storage Router works . . . . .	11
Processing SCSI information. . . . .	11
HP N1200-320 4Gb Network Storage Router features . . . . .	11
Fibre Channel features . . . . .	11
SCSI bus features. . . . .	11
Management features. . . . .	11
External indicators . . . . .	12
HP N1200-320 4Gb Network Storage Router benefits . . . . .	12
Operating and Non-operating environments . . . . .	12
Operating environment. . . . .	12
Non-operating environment. . . . .	12
<b>2 Installation, cabling, and setup. . . . .</b>	<b>13</b>
Identifying product components . . . . .	13
Typical installation configuration tasks. . . . .	13
Installing the HP N1200-320 4Gb Network Storage Router. . . . .	13
Desktop installation . . . . .	14
Rack mount installation. . . . .	14
Separate the rack mount rails . . . . .	14
Attach the outer rail assembly to the rack . . . . .	15
Attach the rear extension bracket . . . . .	16
Attach the rails to the network storage router . . . . .	16
Install the router into the rack . . . . .	17
Connect the power cord . . . . .	17
Setting up serial port communications . . . . .	18
Cabling the N1200-320 4Gb Network Storage Router. . . . .	19
Interfaces and connections . . . . .	19
Fibre Channel connections. . . . .	19
SCSI connection . . . . .	20
Ethernet connection. . . . .	20
Serial port connection . . . . .	21
Autobaud feature. . . . .	21
<b>3 Device management . . . . .</b>	<b>23</b>
SCSI bus configuration . . . . .	23
FC port configuration . . . . .	23
FC arbitrated loop addressing . . . . .	23
Soft addressing . . . . .	23
Hard addressing . . . . .	23
FC switched fabric addressing . . . . .	23
Discovery . . . . .	24
Host bus adapter configuration . . . . .	24
Logical unit management. . . . .	24

<b>4</b>	<b>N1200-320 4Gb Network Storage Router management</b>	<b>27</b>
	Configuration methods	27
	Serial port management access	27
	Out-of-band Ethernet management access	27
	Command Line Interface	28
	Visual manager	29
	FTP	29
	Inband SCSI-3 commands	29
<b>5</b>	<b>Visual manager user interface</b>	<b>31</b>
	Visual manager access	31
	Main menu	32
	Visual Manager menu structure	32
	Home page	33
	System menu	34
	Serial configuration	35
	Network configuration	36
	Active fabric configuration	37
	User security settings	38
	User name and password	38
	Real-Time Clock configuration	39
	Reset menu	40
	Ports menu	41
	Fibre Channel port configuration	42
	SCSI bus configuration	44
	Discovery menu	45
	Mapping menu	47
	Fibre Channel mapping tasks	47
	Viewing and changing Fibre Channel map information	48
	Viewing and changing Fibre Channel host information	48
	Statistics menu	49
	Utilities menu	50
	FTP utility access	51
	Trace settings configuration	52
	Current, previous, and last assert trace displays	53
	Clear current trace buffer or assert trace buffer	53
	Event log settings	53
	Event log display	54
	Clear event log	55
	SCSI command tracking	55
	Report menu	56
	Reboot option	57
<b>6</b>	<b>Using the Command Line Interface</b>	<b>59</b>
	Power-up messages	59
	Perform configuration	60
	Baud rate configuration	61
	Ethernet configuration	62
	Fibre Channel configuration	64
	Parallel SCSI configuration	67
	SCSI initiator menu	68
	Maximum SCSI bus speed menu	69
	Device mapping	70
	Adding an entry	71
	Creating an entry	72
	Remove gaps	73
	Deleting an entry	73
	Adding a host	74
	Deleting a host	75

Editing a host . . . . .	75
Trace and event settings configuration . . . . .	77
Trace configuration . . . . .	77
Event configuration . . . . .	78
Special event logging configuration . . . . .	79
Real-Time clock configuration . . . . .	80
Active fabric configuration . . . . .	80
Save configuration . . . . .	81
Restore last saved configuration . . . . .	81
Reset to factory defaults . . . . .	81
System utilities . . . . .	81
System statistics menu . . . . .	82
Event Log . . . . .	86
Runtime report . . . . .	86
Diagnostics mode . . . . .	87
Special Fibre Channel link control . . . . .	88
SCSI command tracking . . . . .	88
Display trace and assertion history . . . . .	89
Get a copy of trace buffer . . . . .	89
Reboot . . . . .	90
Download a new revision of the firmware . . . . .	90
<b>7 Using the FTP interface . . . . .</b>	<b>91</b>
Backup/restore configuration settings . . . . .	91
Configuration backup procedure . . . . .	91
Configuration restore procedure . . . . .	91
Get a copy of trace buffer or event log . . . . .	92
Updating firmware . . . . .	93
<b>8 Troubleshooting . . . . .</b>	<b>95</b>
General troubleshooting . . . . .	95
What happens if the DHCP server cannot be contacted? . . . . .	95
Indicators . . . . .	95
Basic verification . . . . .	96
Serial port problems . . . . .	96
Login problems . . . . .	96
Windows driver . . . . .	96
Verify SCSI bus configuration . . . . .	97
Verify Fibre Channel connection . . . . .	98
Verify SCSI devices in Windows NT . . . . .	98
Verify configuration . . . . .	98
Verify mapping . . . . .	98
Verify devices . . . . .	98
Verify host configuration . . . . .	98
PRLI data . . . . .	98
Verify HBA device driver information . . . . .	99
Running diagnostics . . . . .	99
Technical support . . . . .	99
HP technical support . . . . .	99

<b>A Pin assignments</b>	<b>101</b>
DB-9 pin assignments	101
RJ-45 Ethernet Pin Assignments	102
<b>B Regulatory compliance and safety</b>	<b>103</b>
Regulatory compliance	103
Regulatory compliance identification numbers	103
Regulatory compliance label location	103
Regulatory model number: EO 1011	103
Emissions classification: Class A	103
Federal Communications Commission notice	103
Class A equipment	103
Class B equipment	103
Declaration of conformity for products marked with the FCC logo, United States only	104
Modifications	104
Cables	104
Laser device	104
Laser safety warning	104
International notices and statements	105
Canadian notice (avis Canadien)	105
Class A equipment	105
Class B equipment	105
European Union notice	105
BSMI notice	105
Japanese notice	106
Korean notices	106
Safety	106
Battery statement	106
Taiwan battery recycling notice	107
<b>C Inband SCSI-3 commands</b>	<b>109</b>
General commands	109
Report LUNs command	109
Inquiry command	110
EVPD Page 0x80	111
Device Identification Page 0x83	111
<b>D Addressing, structures, and operations</b>	<b>113</b>
Auto Assigned addressing option	114
Indexed addressing option	115
SCC addressing option	115
<b>E Enabling DHCP on the HP N1200-320 4Gb Network Storage Router</b>	<b>117</b>
Setting up DHCP over network storage router interfaces	118
Serial and Telnet interfaces	118
Special note regarding Ethernet IP, subnet mask, and gateway addresses	120
Visual Manager	121
Tips for manipulating DHCP within Visual Manager	121
<b>Glossary</b>	<b>123</b>
<b>Index</b>	<b>129</b>

# About this guide

This guide provides information about:

- Installing the HP StorageWorks N1200-320 4Gb Network Storage Router
- Configuring the HP StorageWorks N1200-320 4Gb Network Storage Router
- Troubleshooting the HP StorageWorks N1200-320 4Gb Network Storage Router

## Intended audience

This guide is intended for general users who need physical and functional knowledge of the HP StorageWorks N1200-320 4Gb Network Storage Router.

## Related documentation

In addition to this guide, the following document is available for this product:

- *HP StorageWorks N1200-320 4Gb Network Storage Router Getting Started* poster

This and other HP documents can be found on the HP documents web site:

<http://www.hp.com/support/manuals> .

## Document conventions and symbols

**Table 1** Document conventions

Convention	Element
Medium blue text: <a href="#">Figure 1</a>	Cross-reference links and e-mail addresses
Medium blue, underlined text ( <a href="http://www.hp.com">http://www.hp.com</a> )	Web site addresses
<b>Bold font</b>	<ul style="list-style-type: none"><li>• Key names</li><li>• Text typed into a GUI element, such as into a box</li><li>• GUI elements that are clicked or selected, such as menu and list items, buttons, and check boxes</li></ul>
<i>Italics font</i>	Text emphasis
Monospace font	<ul style="list-style-type: none"><li>• File and directory names</li><li>• System output</li><li>• Code</li><li>• Text typed at the command-line</li></ul>
<i>Monospace, italic font</i>	<ul style="list-style-type: none"><li>• Code variables</li><li>• Command-line variables</li></ul>
<b>Monospace, bold font</b>	Emphasis of file and directory names, system output, code, and text typed at the command line

⚠ **WARNING!** Indicates that failure to follow directions could result in bodily harm or death.

⚠ **CAUTION:** Indicates that failure to follow directions could result in damage to equipment or data.

---

 **IMPORTANT:** Provides clarifying information or specific instructions.

---

 **NOTE:** Provides additional information.

---

 **TIP:** Provides helpful hints and shortcuts.

---

## HP technical support

Telephone numbers for worldwide technical support are listed on the HP support web site:  
<http://www.hp.com/support/>.

Collect the following information before calling:

- Technical support registration number (if applicable)
- Product serial numbers
- Product model names and numbers
- Applicable error messages
- Operating system type and revision level
- Detailed, specific questions

For continuous quality improvement, calls may be recorded or monitored.

HP strongly recommends that customers sign up online using the Subscriber's choice web site:  
<http://www.hp.com/go/e-updates>.

- Subscribing to this service provides you with e-mail updates on the latest product enhancements, newest versions of drivers, and firmware documentation updates as well as instant access to numerous other product resources.
- After signing up, you can quickly locate your products by selecting **Business support** and then **Storage** under Product Category.

## HP-authorized reseller

For the name of your nearest HP-authorized reseller:

- In the United States, call 1-800-282-6672.
- Elsewhere, visit the HP web site: <http://www.hp.com>. Then click **Contact HP** to find locations and telephone numbers.

## Helpful web sites

For other product information, see the following HP web sites:

- <http://www.hp.com>
- <http://www.hp.com/go/storage>
- <http://www.hp.com/support/>
- <http://www.docs.hp.com>



# 1 Introduction

The HP StorageWorks N1200-320 4Gb Network Storage Router provides bi-directional connectivity between one Fibre Channel Switched Fabric (FC-SW) or Fibre Channel Arbitrated Loop (FC-AL), and two Narrow/Wide Fast/Ultra320 LVD/SE SCSI buses.

Supported devices include:

- Initiator Devices – Fibre Channel hosts
- Target Devices – Tape drives

## External features overview

The front of the HP N1200-320 4Gb Network Storage Router is shown in [Figure 1](#).

**Figure 1** HP N1200-320 4Gb Network Storage Router front panel

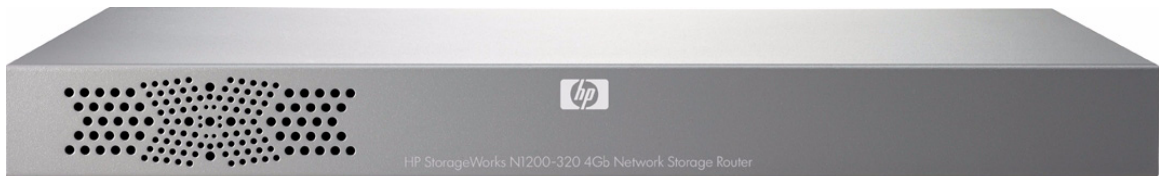

The back of the HP N1200-320 4Gb Network Storage Router is shown in [Figure 2](#).

**Figure 2** HP N1200-320 4Gb Network Storage Router back panel

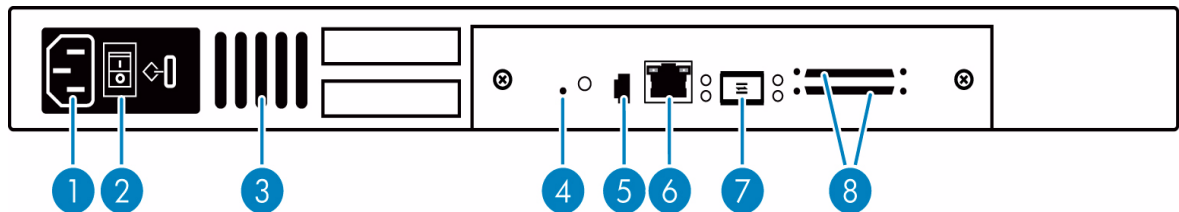

**Table 2** HP N1200-320 4Gb Network Storage Router

Number	Description
1	Power connector
2	On/Off switch
3	Cooling vents
4	Reset access hole
5	Serial port
6	10/100 Ethernet port
7	Fibre Channel port
8	Two SCSI busses

In addition to Fibre Channel and SCSI interfaces, there are Ethernet and serial ports that provide connectivity for configuration and management access. The LEDs (operation indicators) provide basic status information. A reset access hole is also provided for a manually forced reboot of the network storage router.

## Operation indicators

The HP N1200-320 4Gb Network Storage Router has LED indicators for monitoring overall status as shown in Figure 3.

**Figure 3** Operation indicators

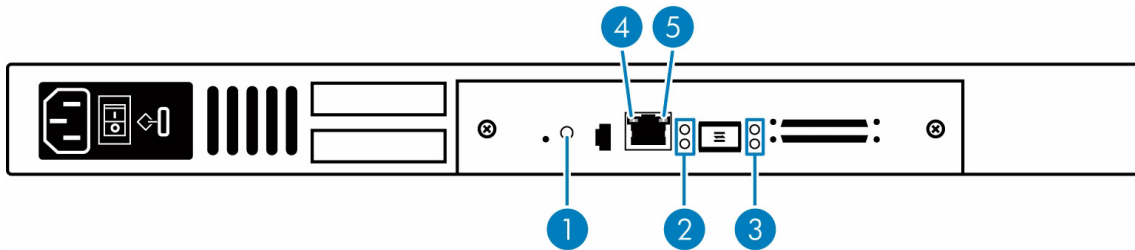

**Table 3** Operation indicators

Number	Description
1	Power and Fault (Pwr) LED
2	Fibre Channel port LEDs link (LNK) indicator (top) and activity (ACT) indicator (bottom)
3	SCSI bus 0, 1 LEDs
4	Ethernet LED link (LNK) indicator
5	Ethernet LED activity (ACT) indicator

The LED functionality of the network storage router is detailed below:

- **Power and Fault (Pwr)** – The bi-color LED is green when power is active, and is continuously amber when the network storage router detects a fault condition.
- **Fibre Channel LNK/ACT**– When green, the LNK indicator signifies a good Fibre Channel link. When green, the ACT indicator signifies Fibre channel port activity.
- **SCSI bus (0, 1)** – When lit, these green indicator LEDs signify SCSI activity for the associated bus.
- **Ethernet (10/100)** – The LNK indicator (left) will stay permanently lit to indicate an Ethernet link. The ACT indicator (right) should flash to indicate Ethernet activity.

## How the HP N1200-320 4Gb Network Storage Router works

The network storage router is a device that translates the Fibre Channel Protocol (FCP) to and from the SCSI Protocol—transparently transferring commands, data, and status information—so that both the Fibre Channel (FC) and SCSI devices and hosts can communicate with each other. Interconnection is provided between two SCSI buses and one Fibre Channel Arbitrated Loop or Switched Fabric, making use of Fibre Channel's ability to encapsulate SCSI protocol packets.

### Processing SCSI information

The following section describes how the network storage router processes SCSI information when attached to FC hosts.

1. A FC host issues a command, then encapsulates the command in the FC protocol and sends the packet to the network storage router.
2. The network storage router receives the packet, interprets the FC information, and places the packet in buffer memory.
3. The processor interprets the information and programs an internal SCSI controller to process the transaction.
4. The SCSI controller sends the command to the SCSI device (target).
5. The SCSI target interprets the command and executes it.
6. Data flows between the FC host and SCSI target through payload buffers.
7. Response information flows from the SCSI target back to the FC host.

## HP N1200-320 4Gb Network Storage Router features

### Fibre Channel features

- One FC port (selectable between 4.25, 2.125 and 1.0625 Gbps)
- Fibre Channel Arbitrated Loop (FC-AL) including Point-to-Point configurations in arbitrated loop topology only and Switched Fabric (FC-SW) topologies
- Private Loop Direct Attach (PLDA) profile compliant
- Class 3 operation with SCSI-FCP protocol
- Supports FCP-2 error recovery protocol as specified in FCP-2 rev. 04 and 05 for use with streaming devices (such as tape)
- Optical SFP support (Shortwave)

### SCSI bus features

- Auto-negotiation for Narrow, Wide, Fast, and up to Ultra320
- Concurrent commands, tagged command queuing and disconnect/reconnect
- SCSI-2 and SCSI-3 protocols
- Connection type is VHDCI 68-pin D shell, P type connectors
- LVD/single-ended termination
- Tape, optical, and changer devices

### Management features

- Network storage router LUN commands
- Out-of-band Ethernet TCP/IP management access
- DHCP for easier network addressing
- Serial 3-pin connector for terminal access
- Ethernet RJ-45 connector for FTP, Telnet, and Web browser access
- Firmware that can be updated in the field
- SCC (FC only), Indexed, and Auto Assigned addressing modes

## External indicators

- Fibre Channel link status and activity LEDs
- SCSI bus activity LED
- Ethernet link status and activity LEDs
- Power/Fault LED

## HP N1200-320 4Gb Network Storage Router benefits

The network storage router is designed to connect SCSI devices into a Fibre Channel (FC) fabric or loop. The network storage router comes with one 4 Gb/s Fibre Channel port and two LVD/SE SCSI buses.

The Fibre Channel ports can be set for 1, 2, or 4 Gb/s speeds and can connect in arbitrated loop (including point-to-point configurations) or switched fabric topologies. SCSI buses automatically negotiate for Fast, Narrow, Wide, and up to Ultra320 SCSI.

## Operating and Non-operating environments

### Operating environment

- 0 to 50°C, 32 to 122°F
- 5 to 80% relative humidity (non-condensing)

### Non-operating environment

- -40 to +55°C, -40 to 131°F
- 0 to 92% relative humidity (non-condensing)

---

## 2 Installation, cabling, and setup

---

 **NOTE:** Read this chapter carefully and completely before working with the network storage router.

---

### Identifying product components

The network storage router kit:

- HP N1200-320 4Gb Network Storage Router
- Accessory kit
  - Two rack mount assembly rails
  - Two rack mount extender brackets
  - One bag of mounting hardware with: eight #10-32 x 6 Phillips screws, and eight #6-32x 312 Phillips screws
- Documentation bundle
  - Documentation CD
  - Safety CD
  - Warranty guide
  - HP product documentation survey
- Stick-on feet
- Serial cable
- Power cable
- Getting Started poster

### Typical installation configuration tasks

- Change the Administrative password if desired (see "[User security settings](#)" on page 38)
- Change the network settings if needed (see "[Network configuration](#)" on page 36)
- Set the date and time (see "[Real-Time Clock configuration](#)" on page 39)
- Verify that the default map is Indexed (see "[Mapping menu](#)" on page 47)
- Edit the Fibre Channel Port 0 map so that it is filled with the SCSI devices (library and drives) that are communicating over Fibre Channel (see "[Fibre Channel port configuration](#)" on page 42)
- Assign the Fibre Channel Port 0 map to any hosts that need to communicate with the SCSI devices (library and drives) (see "[Fibre Channel port configuration](#)" on page 42)

### Installing the HP N1200-320 4Gb Network Storage Router

Remove the network storage router from the box and place it on a flat and stable work surface. Save the packaging materials in the event the router will be shipped in the future.

The N1200-320 4Gb Network Storage router can be placed on a desktop or installed in a standard 19-inch rack. When considering a location, make sure the airflow area surrounding the front and back of the router is unobstructed.

---

 **IMPORTANT:** The size of the router and its rail assembly is 1U.

---

## Desktop installation

Remove the router from the protective bag. Attach the stick-on feet to the bottom four corners of the router. Place the router on a flat, level table or desktop making sure the airflow vents are clear of obstructions.

**⚠ WARNING!** Do not place objects on top of the network storage router.

## Rack mount installation

**📋 IMPORTANT:** The size of the router and its rail assembly is 1U.

The following items in the N1200-320 4Gb Network Storage Router kit are used to install the router into a rack:

- Two rack mount assembly rails
- Two rack mount extender brackets
- One bag of mounting hardware to include eight #10-32x 6 Phillips screws, and eight #6-32x 3/12 Phillips screws

**📋 IMPORTANT:** You need a #2 Phillips and a #2 flat-head screwdriver for this procedure.

To install the network storage router into a rack, determine where the router will be installed in the rack, making sure the airflow vents remain clear of obstructions.

### Separate the rack mount rails

1. Separate the inner rail from the outer rail by placing a thumb over the circular hole at the front-end of the inner rail, and extend the inner rail out from the outer rail until it locks into place.
2. Press the spring latch on the back of the inner rails to release the lock.
3. While holding down the spring latch, extend the inner rail until the two rails separate.
4. Repeat this process to separate the other set of rails.

**Figure 4** Separate rack mount rails

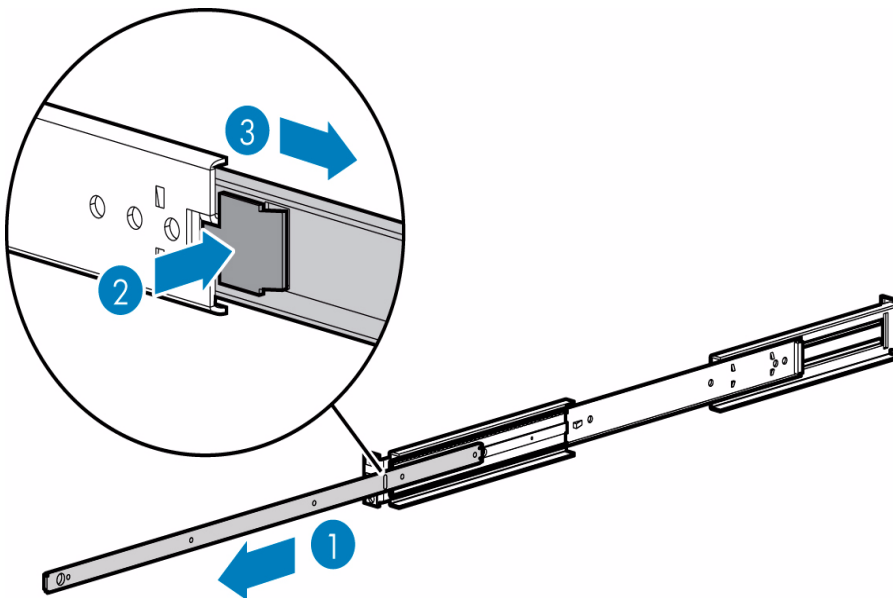

## Attach the outer rail assembly to the rack

 **NOTE:** The size of the router and the rail assembly is 1U.

1. Determine the correct rack location.
2. Align the three screw holes on the front of the outer rail assembly with the front of the rack. All three holes must be exactly aligned.
3. With the outer rail assembly flush against the inside front of the rack, insert two 10-32 x 6 Phillips screws, and tighten. Do not insert a screw in the center hole of the bracket.

**Figure 5** Attaching the outer rail assembly to the rack

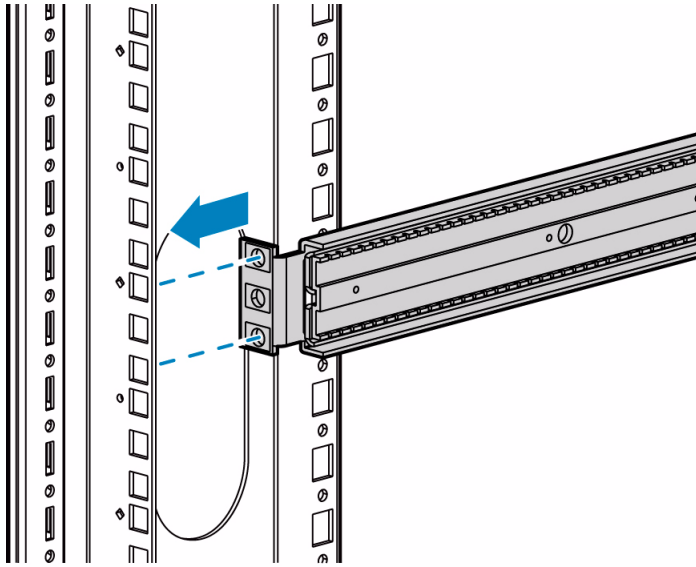

## Attach the rear extension bracket

1. Loosen the screw on the rear extension bracket of the outer rail assembly.
2. While holding the outer rail assembly level, extend the rear extension bracket to the inside of the rear of the rack.
3. Attach the rear extension bracket to the rear of the rack using two of the 10-32 x 6 Phillips screws.
4. With the outer rail assembly in place, tighten the screw that connects the rear extension bracket to the outer rail.
5. Repeat this process to attach the remaining outer rail assembly to the other side of the rack.

**Figure 6** Attaching the rear extension bracket

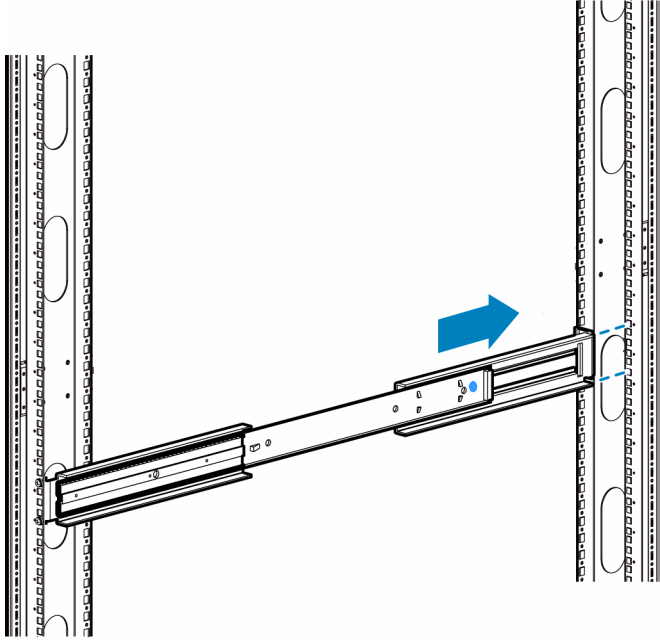

## Attach the rails to the network storage router

1. With the spring latch facing away from the router (4 in [Figure 7](#)) and the circular hole facing the front of the router (2 in [Figure 7](#)), align the first screw hole on the rail (3 in [Figure 7](#)) with the center screw hole on the router. Using this alignment, two screw holes will be aligned and the rail will extend out from the front of the router approximately eight inches (1 in [Figure 7](#)).
2. Secure the rail to the router using two 6-32x 312 Phillips screws.
3. Repeat this process to attach the inner rail to the other side of the router.

**Figure 7** Attaching the rails to the router

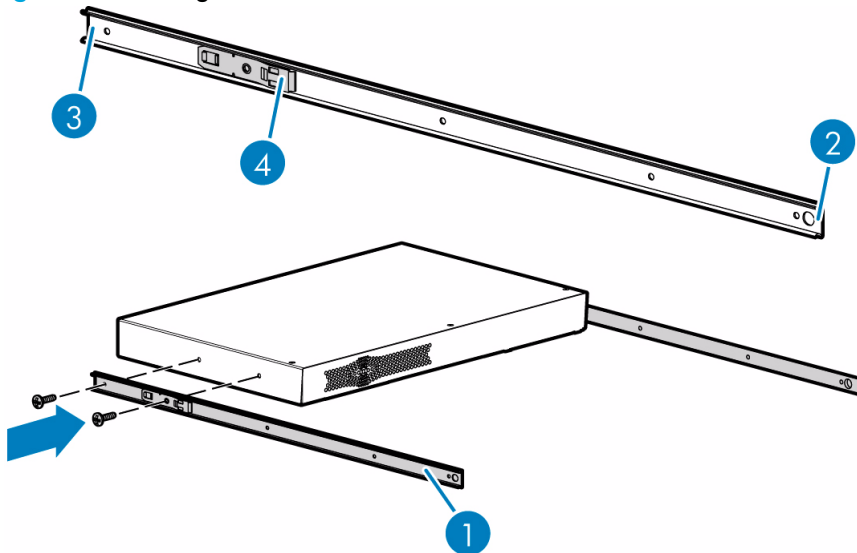



## Install the router into the rack

1. Move the ball-bearing slide on each of the outer rails towards the front of the rack.
2. From the front of the rack, with the front side of the router facing out, align the inner and the outer rails and slide the inner rail into the outer rail.
3. When the rails lock in place, press in the spring latches on each of the inner rails and push the router into the rack.

**Figure 8** Installing the router in the rack

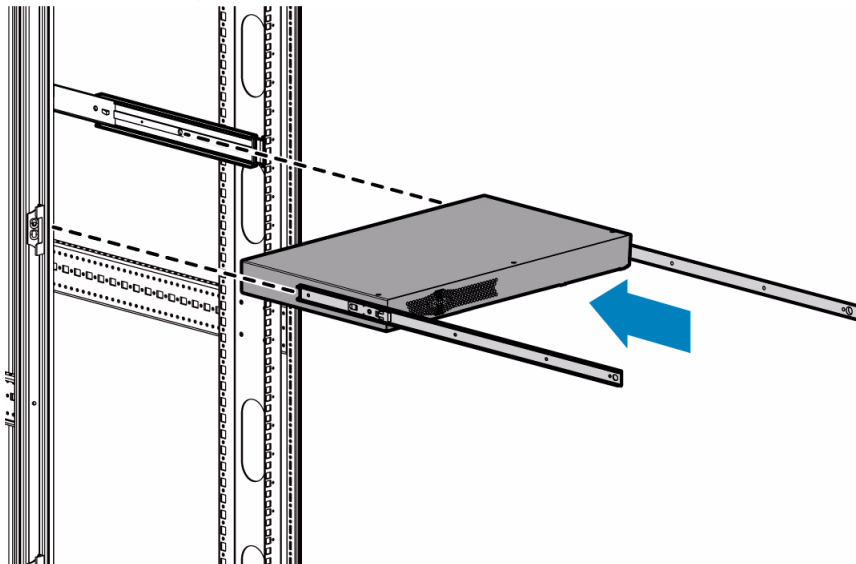

## Connect the power cord

---

**IMPORTANT:** Before supplying power to the network storage router, HP recommends setting up serial port communications with your host computer, unless serial I/O was previously established and is currently running (see ["Setting up serial port communications"](#) on page 18).

---

**IMPORTANT:** The power cord shipped with the network storage router is a 120 VAC three-conductor power cord for use in the United States and Canada. If the router is being installed outside the United States or Canada, the appropriate power cord should be purchased.

---

Connect the power cord to the power connector on the back of the router. Connect the other end of the power cord to a grounded voltage source.

**Figure 9** Power cord connection

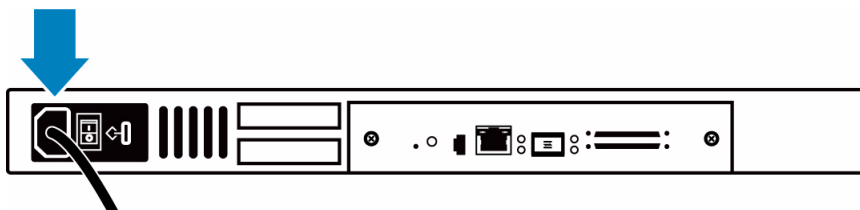

## Setting up serial port communications

The network storage router is designed to communicate with a terminal or any operating system utilizing a terminal emulator. For example, most Windows® operating systems can use a terminal. Be sure the baud rate, data bits, stop bits, parity, and flow control are set correctly.

To set up serial communications with the network storage router:

1. Plug the serial cable into one of the host computer's serial ports (COM1 or COM2), and then plug the other end of the serial cable into the network storage router's serial port (see [Figure 2](#) on page 9).
2. Start the terminal emulator.
3. Set the terminal emulator to use the appropriate COM port.
4. Specify the following settings for the port:

Baud Rate:	9600, 19200, 38400, 57600, or 115200 (Autobaud only recognizes these baud rates)
Data Bits:	8
Stop Bits:	1
Parity:	None
Flow Control:	None or XON/XOFF

---

 **NOTE:** Before initially applying power to the network storage router, make sure all the SCSI devices are powered on first, and that they have finished performing individual self tests. This helps to ensure that device discovery works correctly.

---

5. Apply power to the network storage router. The power-up process can take up to 90 seconds. Once complete, the main menu should be accessible.

# Cabling the N1200-320 4Gb Network Storage Router

---

 **NOTE:** Refer to the *HP StorageWorks MSL2024 or the MSL4048 Tape Library User and Service Guide* for detailed tape library information.

---

## Interfaces and connections

There are four types of interfaces to the network storage router:

- Fibre Channel
- SCSI
- 3-pin serial port
- Ethernet

The 3-pin serial and Ethernet ports are used for configuration and management of the network storage router.

For convenience in configuring ports, key information is indicated on the back panel of the network storage router such as WWN name, WWP name, and Ethernet MAC ID (Physical Address).

## Fibre Channel connections

Before connecting the network storage router to other devices, it is important to understand the configuration requirements of the environment to which it is connected.

---

 **IMPORTANT:** Failure to correctly configure a Fibre Channel device may impair the operation of the Storage Area Network (SAN) to which it is attached.

---

Typical installations have the network storage router connected to a Switched Fabric environment. For an Arbitrated Loop, the unit can be directly attached to the Fibre Channel host bus adapter. In Fibre Channel switched environments, the switch is also directly attached to the network storage router.

Both FC switches and hubs may allow for individual ports to be configured for different media types. The network storage router must be connected to the hub or switch port with the appropriate FC cabling for the media type in use on both the network storage router and the port to which it is connected.

The network storage router supports various Fibre Channel media types through the use of external Small Form Factor Pluggable Transceivers (SFPs).

Supported media type: **Multi-Mode Fiber** - 4.25 Gbit Dual LC connectors.

To connect the network storage router to the Fibre Channel SAN:

1. Locate the Fibre Channel port on the network storage router (see [Figure 2](#) on page 9).
2. Remove the rubber protector from the SFP.
3. With the network storage router powered off, connect the router into the Fibre Channel environment using the appropriate cabling. The FC optical connector on the network storage router is keyed. Be sure to insert the cable connectors in the proper orientation.

## SCSI connection

---

- △ **CAUTION:** SCSI ports on the network storage router are not hot-pluggable. Power off the network storage router whenever connecting/disconnecting the SCSI cables.
- 

The network storage router can support Fast/Ultra320 Narrow/Wide SCSI, depending on the specific configuration. The network storage router is factory configured to support LVD/Single-Ended buses. Two VHDCI 68-pin D-shell, P-type connectors are available, allowing the unit to be attached at the end of up to two SCSI buses. The network storage router must always be installed at the end of SCSI buses.

The network storage router supplies termination power (TERMPWR) to each SCSI bus. An internal self-resetting fuse in the TERMPWR resets after a fault is cleared.

---

- △ **CAUTION:** Do not plug HVD devices to an LVD/SE bus. Failure to follow this caution may result in severe damage to equipment.
- 

To connect the network storage router to a SCSI bus:

1. Power off the network storage router.
2. Power off the SCSI devices on this bus.
3. Connect a SCSI cable to one of the SCSI connectors on the router. The network storage router should always be installed at the end of the SCSI bus.
4. Make sure that the bus is terminated correctly. By default, the network storage router is automatically terminated. However, the device at the other end of the bus must also be terminated.

## Ethernet connection

A 10/100BaseT Ethernet connection provides management and configuration access. The RJ-45 connector on the unit can be directly connected to a standard 10/100BaseT Ethernet network.

---

-  **NOTE:** You should change the pre-filled in settings if you disable DHCP, because while they are valid settings, a conflict occurs if more than one network storage router is on the network with these initial settings.
- 

Setting the IP network address is recommended, but not required, in order to configure the network storage router from this port. The IP network address can be manually assigned or dynamically assigned (using DHCP). The default network configuration is DHCP, but if DHCP is turned off, the initial value for the IP address is 1.1.1.1, the Subnet is 255.255.255.0, and the Gateway is 0.0.0.0.

Depending on the network environment, you may be able to temporarily use the IP address of 1.1.1.1 to configure the network storage router. For more about the IP network address, refer to “[Network configuration](#)” on page 36.

Ethernet capabilities include Telnet support for configuration and management and FTP support for other management capabilities.

## Serial port connection

The 3-pin connector on the network storage router provides a serial port that is compatible with RS-232 signaling levels. The network storage router is designed to communicate with a terminal or any operating system using a terminal emulator. The baud rate, data bits, stop bits, parity, and flow control of both the network storage router and the host system must use the same settings. The Autobaud feature described below provides an effective method to set the baud rate of the network storage router and host system.

### Autobaud feature

The Autobaud feature automatically configures the baud rate on the network storage router. Once you set the baud rate in the terminal emulator, wait until the network storage router completes the Power-On Self Test (POST) and then the firmware initialization process. This can take up to 90 seconds, during which time the POST and initialization information may or may not be visible on the terminal or terminal emulator. After this process has completed, you can press the **Enter** key slowly seven or eight times (or just type **shift-z**) and the network storage router automatically detects the baud rate being used by the serial port. The baud rate is then saved in the network storage router's configuration and is retained through future power cycles.

---

 **NOTE:** Pressing the **Enter** key before the POST has completed is of no benefit to the Autobaud feature. Wait at least 90 seconds until both the POST and the firmware Initialization processes have completed before pressing the **Enter** key.

---

 **NOTE:** If there is no response using the **Enter** key, press the space bar slowly seven or eight times, and then press the **Enter** key slowly seven or eight times.

---

The baud rate used by the terminal or terminal emulator must be 9600, 19200, 38400, 57600, or 115200 for the Autobaud feature to recognize it. The network storage router does not function properly at any other baud rate.



---

## 3 Device management

To provide connectivity between hosts and devices, it is necessary for the network storage router to be recognized with an address on the connected Fibre Channel network.

### SCSI bus configuration

The network storage router provides the capability to reset SCSI buses during the network storage router boot cycle. This allows the devices on a SCSI bus to be set to a known state. Configuration provides for the SCSI bus reset feature to be enabled or disabled.

The network storage router negotiates for the maximum values for transfer rates and bandwidth on a SCSI bus. If an attached SCSI device does not allow the full rates, the network storage router uses the best rate it can negotiate for that device. Negotiation is on a device specific basis, so the unit can support a mix of SCSI device types on the same SCSI bus.

### FC port configuration

By default, the configuration of the FC port on the network storage router is set to N\_Port mode. For more information, see the Fibre Channel Configuration sections in "[N1200-320 4Gb Network Storage Router management](#)" on page 27 and "[Fibre Channel port configuration](#)" on page 42.

### FC arbitrated loop addressing

On a Fibre Channel Arbitrated Loop, each device appears as an Arbitrated Loop Physical Address (AL\_PA). To obtain an AL\_PA, two addressing methods, called **soft** and **hard** addressing, can be used by the network storage router. Soft addressing is the default setting. For hard addressing, the user specifies the AL\_PA of the network storage router.

#### Soft addressing

When acquiring a soft address, the network storage router acquires the first available loop address, starting from address **01** and moving up the list of available AL\_PAs in the chart from **01** to **EF**. In this mode, the network storage router obtains an available address automatically and then participates on the FC loop, as long as there is at least one address available on the loop connected to the network storage router. Fibre Channel supports up to 126 devices on an Arbitrated Loop.

#### Hard addressing

When acquiring a hard address, the network storage router attempts to acquire the AL\_PA value specified by the user in the configuration settings. If the desired address is not available at loop initialization time, the network storage router comes up on the FC loop using an available soft address. This allows both the loop and the unit to continue to operate. An example of this scenario would be when another device on the Arbitrated Loop has acquired the same address as that configured on the network storage router.

Hard addressing is recommended for FC Arbitrated Loop environments where it is important that the FC device addresses do not change. Device address changes can affect the mapping represented by the host operating system to the application, and have adverse effects. An example of this would be a tape library installation, where the application configuration requires fixed device identification for proper operation. Hard addressing ensures that the device identification to the application remains constant.

### FC switched fabric addressing

When connected to a Fibre Channel switch, the network storage router is identified to the switch as a unique device by the factory programmed World Wide Name (WWN) and the World Wide Port Names (WWPN), which are derived from the WWN.

## Discovery

Discovery is a feature that makes it easy to display attached FC and SCSI target devices and have them mapped automatically on the host side for the connected bus/port.

There are two discovery methods available—**Manual Discovery** and **Auto Discovery**. Auto Discovery can be set to occur after either reboot events (when the card reboots) or link-up events (for instance, when cables are attached or a hub is rebooted). Discovery can also be turned off by setting the network storage router to **Manual Discovery Only**. The default setting for FC Discovery is Manual Discovery.

For specific information on Discovery settings, see the Fibre Channel configuration and SCSI configuration sections in “[N1200-320 4Gb Network Storage Router management](#)” on page 27 and “[Discovery menu](#)” on page 45.

## Host bus adapter configuration

A host system using a Fibre Channel Host Bus Adapter (HBA) typically maps devices into the existing device mapping scheme used by the host operating system. Refer to the HBA manual for the mapping table.

Mapping usually involves pairing FC AL\_PAs to SCSI target addresses. The HBA claims enough SCSI bus entries to allow for 125 FC targets to map to SCSI bus:Target entries. This is usually done by a fixed mapping of AL\_PA to Bus:Target. In such a configuration, the network storage router corresponds to a Bus:Target identifier, with the SCSI devices attached to the network storage router appearing as logical units (LUNs). Operating systems can extend the available SCSI limit of 15 targets per bus. Although this is not an issue for the operating system or most applications, there are cases where older applications can have expectations about what are valid SCSI IDs, and not correctly handle certain mappings. In particular, applications have been seen to exhibit difficulties addressing target IDs greater than 15 (e.g. 16 and up). This problem can be resolved by configuring the network storage router to use hard addressing, and setting the AL\_PA used by the unit to a value that the HBA will map to an ID with a value less than 16.

For example, depending on the FC HBA, if the hard AL\_PA selection is 1, the network storage router address is 1. If the selection is 125, the network storage router address is 0xEF. Some FC HBAs configure differently, so verify the AL\_PA by reviewing the documentation for the HBA.

## Logical unit management

Because SAN resources can be shared, multiple hosts can have access to the same devices on the SAN. To prevent conflicts, the network storage router provides the means to restrict access and only allow hosts to find and access selected devices. Simple LUN masking can restrict access, but many times this leaves gaps in the list of LUNs presented to a host, since devices are always associated with fixed LUNs. The network storage router, however, provides controlled access to devices by use of LUN management, which goes beyond simple LUN masking.

LUN Management is the ability to present different hosts with different views of the devices accessed through the network storage router. For example, one FC host may see three disk LUNs and a tape LUN at LUNs 0 to 3 when it performs discovery on the network storage router. Another FC host may only discover a tape LUN at LUN 0. Not only can the administrator control which devices a host may access, but also which LUNs are used to access these devices.

LUN Management is accomplished by allowing the administrator to configure multiple maps, each of which may present a different view of the devices behind the network storage router. Each host accessing the network storage router can be associated with a specific map.

For a host connected to an FC port, a map is a table of LUNs where each entry in the table is either empty or contains device address information needed to route commands to the appropriate device.

The FC port on the network storage router has a set of maps which include user defined maps and a few special predefined maps.

There are currently four special predefined maps: Indexed, Auto Assigned, SCC, and Port 0 device maps. Until a user configures the network storage router otherwise, the default map setting is Indexed.



- The Indexed map is initially empty and can be modified by the user, however, this is not recommended.
- The Auto Assigned map is built dynamically, and contains all the devices found during discovery. This map changes automatically any time the discovery process finds a change in the devices attached to the network storage router. This map can be displayed, but cannot be modified directly by the user.
- The SCC map is only available on the FC port and contains a single entry. LUN 0 is an network storage router LUN, and access to devices behind the controller is handled by using SCC logical unit addressing.

When a host sends a command to the network storage router, the network storage router selects which map to use, based on the ID of the host sending the command. For FC ports, the host ID is the World Wide Name. For SCSI buses, the host ID is the initiator ID (0 - 15). When a host is unknown to the network storage router, or is not attached to a specific map, the network storage router uses the default setting for mapping. The default setting for each port can be set to Auto-assigned, Indexed, or SCC (which applies to the FC port only) by the user.



---

## 4 N1200-320 4Gb Network Storage Router management

The HP N1200-320 4Gb Network Storage Router can be managed over the following user interfaces:

- Over the serial port via a terminal or a terminal emulation utility (see “[Setting up serial port communications](#)” on page 18).
- Over Ethernet via a Telnet utility or an HTTP-based interface called Visual Manager. Additionally, FTP support provides additional management functionality (see “[Visual manager user interface](#)” on page 31).

Before attempting to configure the network storage router, a basic understanding of Fibre Channel and SCSI devices is recommended.

---

 **NOTE:** For information on SCSI standards, refer to publications from the X3T10 committee of ANSI (American National Standards Institute). For information on Fibre Channel standards, refer to publications from the X3T11 committee of ANSI. For those who are interested in purchasing approved American National Standards and Technical Reports, you can contact ANSI at (212) 642-4900.

---

### Configuration methods

The network storage router can be configured over the serial port via a terminal or terminal emulation utility, over Ethernet via a Telnet utility or Web browser. FTP is also supported on Ethernet.

### Serial port management access

The serial port allows for configuration of device characteristics from an attached terminal or terminal emulator (see “[Setting up serial port communications](#)” on page 18).

---

 **NOTE:** A Serial connection cannot be made if a Telnet session (discussed later) is already open. If a user attempts to open a serial connection while a Telnet session is already open, the following message appears over the serial interface:

```
System in use via Telnet. Shell restarted.
```

The serial interface resumes working when the Telnet session closes.

---

### Out-of-band Ethernet management access

DHCP is enabled by default. The first time you use the network storage router, use the serial interface to identify the network settings that were assigned from the DHCP server, or to set a new static setting.

When DHCP is disabled, the pre-filled in values are IP address 1.1.1.1, a subnet mask of 255.255.255.0, and a gateway address of 0.0.0.0. HP recommends that at a minimum, the IP address should be changed.

---

 **CAUTION:** HP strongly recommends not having two network storage routers using the pre-filled in static IP address on the same network, as this causes a conflict.

---

When setting the IP address for the network storage router, there are two options:

- The first option is to enter a fixed, or permanent IP address for the network storage router.
- The second option is to enable DHCP on the network storage router, so that a DHCP server (on the Ethernet network used by the network storage router) can assign a dynamic IP address to the network storage router.

Your DHCP server may also allow you to set up an extended lease reservation for an IP address, by providing the server with the Ethernet MAC address of the network storage router. This configures the DHCP server to always provide the same IP address to the network storage router. This setup can be useful for remote management of the network storage router via Telnet. Because the method of setting up a lease reservation varies depending on the DHCP server being used, HP recommends that you contact your Network Administrator for assistance.

For more information about enabling DHCP on the network storage router, see "[Enabling DHCP on the HP N1200-320 4Gb Network Storage Router](#)" on page 117.

## Command Line Interface

The network storage router is capable of holding Telnet sessions for configuration purposes. Access to the configuration menus via the serial port will be disabled when a Telnet session is connected. To open a Telnet session, the IP address of the network storage router and a Telnet client utility are required.

---

 **NOTE:** Rebooting the network storage router closes the Telnet session. After the network storage router reboots and completes POST, the user must restart or re-open the Telnet session.

---

---

 **NOTE:** Resetting to factory defaults from the Telnet interface does not affect Ethernet activity. User configured values for the IP address, gateway, and subnet mask are retained after the network storage router reboots. User name and password are not retained.

---

---

 **NOTE:** The network storage router supports only one Telnet session at a time.

---

From most Windows systems, users can start a Telnet session from the DOS (or Command) prompt using the following steps:

1. From the Windows Start menu, open the DOS (or Command) prompt window.
2. At the '>' prompt, enter the following command  

```
TELNET <IP address>
```

where *<IP address>* is the IP address of the network storage router. This starts a Telnet session window for the network storage router.
3. Enter `root` for the default user name and `password` for the default password. HP recommends that you change the user name and password as soon as possible.
4. Access configuration options in the same way used for the serial interface.
5. To exit the Telnet session, select the **Disconnect** option from your Telnet client utility. In most Telnet utilities, this option is available as a menu item. If working from the Command Prompt in Windows, simply close the window to end the session.

## Visual manager

The network storage router allows any standard Internet Web browser to view and change the network storage router's configuration with the Visual Manager interface. Information is dynamically generated in an HTML format by the network storage router, so that Web browsers can access it.

To access Visual Manager, enter the IP address of the network storage router into the Address field of a Web browser. Or, you can enter a URL using a host name defined by the user—for instance, **http://HPN1200-3204Gb** (but the user must define the host name on the DNS server first for this to work).

To make changes to network storage router settings, use standard keyboard and mouse controls to input information, and then select the **Submit** button to send the changes to the network storage router.

A user name and password are required before any changes can be submitted. The default user name is **root** and the default password is **password**. HP recommends that you change the user name and password as soon as possible (see ["User name and password"](#) on page 38).

Other than dynamic mapping changes, any other changes will not take effect until the next time the network storage router reboots. You can force the network storage router to reboot by selecting the **Reboot** option.

For more information about the Visual Manager interface, refer to ["Visual manager access"](#) on page 31.

---

 **NOTE:** For the VM interface's dynamic display of the network storage router configuration to be presented properly, use version 6.2 or later of Netscape's browser on non-Solaris platforms, or Netscape version 6.2.3 for Solaris platforms. If using Internet Explorer, use revision 6.0 or later.

---

## FTP

The network storage router includes support of File Transfer Protocol (FTP) for updating firmware, saving trace buffers, and backing up/restoring of configuration settings. FTP functionality is described in more detail in ["Using the Command Line Interface"](#) on page 59. There is also an FTP Utility available within Visual Manager (VM) that is described in ["FTP utility access"](#) on page 51.

## Inband SCSI-3 commands

The network storage router supports a set of SCSI-3 commands that can be received as FCP commands over the Fibre Channel ports. When using these commands, they must be sent to a tape LUN or network storage router LUN of the network storage router. For more information, see ["Inband SCSI-3 commands"](#) on page 109 and ["HP N1200-320 4Gb Network Storage Router features"](#) on page 11.



---

## 5 Visual manager user interface

The HP N1200-320 4Gb Network Storage Router allows any standard Internet Web browser to view and change the network storage router's configuration with the Visual Manager interface. Information is dynamically generated in an HTML format by the network storage router so that Web browsers can access it.

To access Visual Manager, enter the IP address of the network storage router into the address field of a Web browser. Or, enter a URL using a host name defined by the user—for instance, **http://HPN1200-3204Gb**. (But the user must define the host name on the DNS server first, for this to work).

To make changes to network storage router settings, use standard keyboard and mouse controls to input information, and then select the **Submit** button to send the changes to the network storage router.

A user name and password are required before any changes can be submitted. The default user name is **root** and the default password is **password**. HP recommends that you change the user name and password as soon as possible (see "User name and password" on page 38).

Other than dynamic mapping changes, any other changes will not take effect until the next time the network storage router reboots. You can force the network storage router to reboot by selecting the **Reboot** option.

---

 **NOTE:** For the VM interface's dynamic display of the network storage router configuration to be presented properly, use version 6.2 or later of Netscape's browser on non-Solaris platforms, or Netscape version 6.2.3 for Solaris platforms. If using Internet Explorer, use revision 6.0 or later.

---

### Visual manager access

Visual Manager (VM) can be accessed from any standard Web browser:

1. Connect an RJ45 Ethernet cable to the back of the network storage router.
2. Obtain the IP address of the network storage router.
3. Enter the network storage router IP address in the address field of the Web browser of the host computer.

---

 **NOTE:** To access VM, the network storage router must be assigned a valid IP address. The factory default setting for the IP address is DHCP.

---

---

 **NOTE:** If you don't know the IP address of the network storage router, connect to the network storage router using the serial connection (see "Setting up serial port communications" on page 18). You can view and change the current settings from the serial interface's Ethernet menu.

---

The Visual Manager home page is displayed, showing network storage router status information. The home page is accessible to anyone who knows the network storage router IP address.

4. Select the desired menu option to access menus and screens. The Password dialog box is displayed. See [Figure 10](#) on page 32 for an example of the Password Dialog box.

5. Enter the authorized user name and password. The user name and password are case-sensitive. The default user name is `root` and the default password is `password`.

**Figure 10** Password dialog box

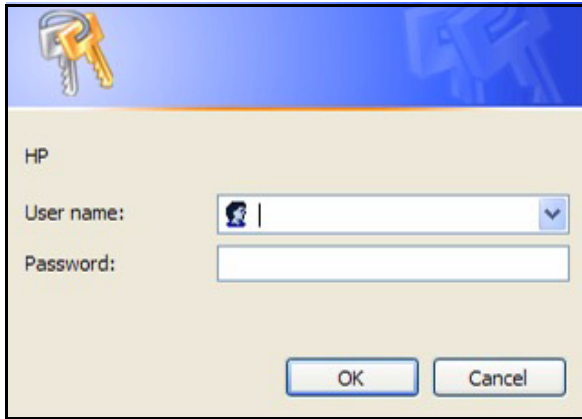

**NOTE:** HP recommends changing the user name and password from the defaults (see “User name and password” on page 38).

**NOTE:** To end the current session of VM, the browser window must be closed. Navigating the browser to another URL does not end the current session.

## Main menu

### Visual Manager menu structure

**Figure 11** Visual Manager menu

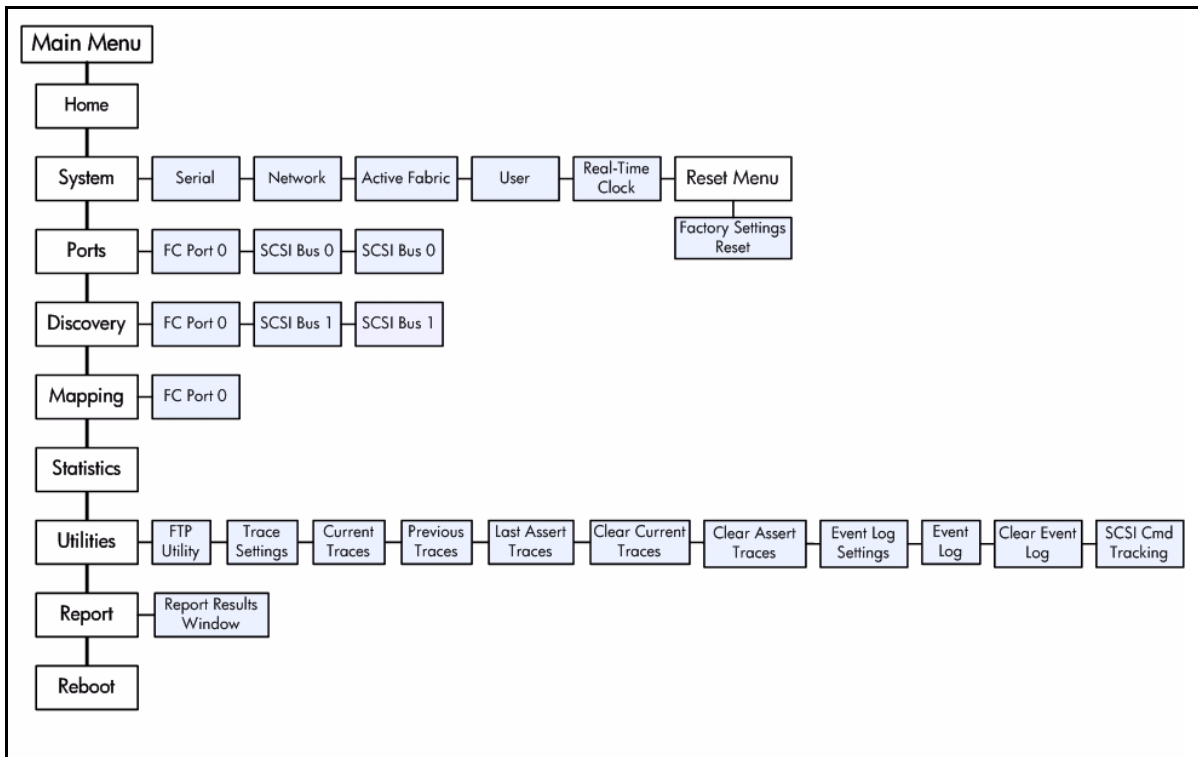



## Home page

The Main menu home page is displayed when Visual Manager (VM) is accessed.

The home page contains status information, including a physical image of the network storage router (see [Figure 12](#)).

**Figure 12** Visual Manager Home page

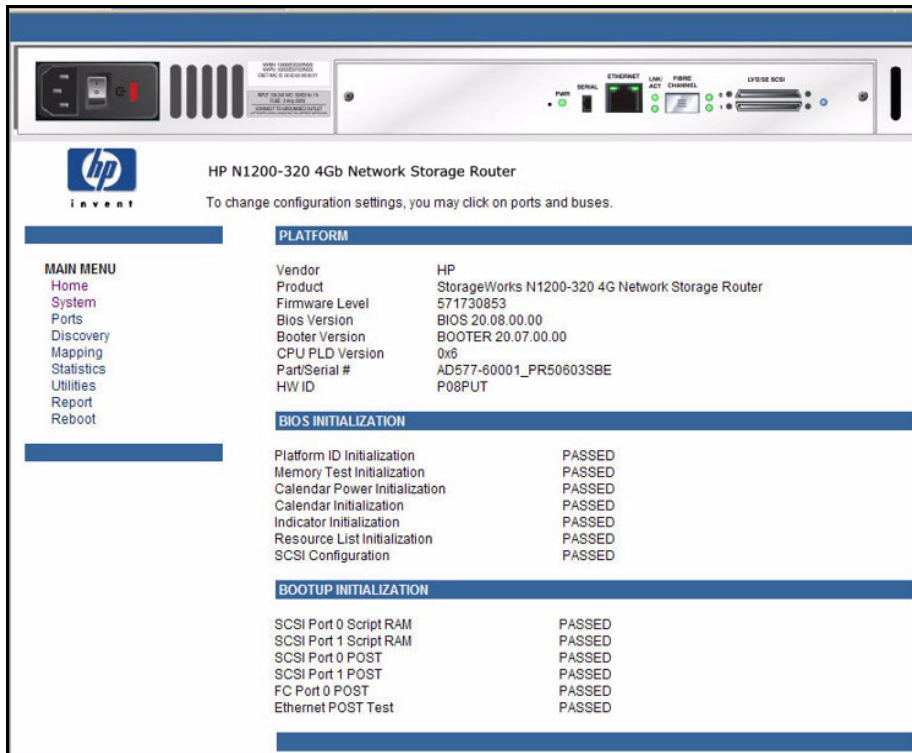

Home page information includes:

- The HP logo is located in the upper left corner of the Home page. If the Internet is accessible to the host, click the HP logo to open the web site.
- An illustration of the network storage router is located near the top of the home page. [Figure 13](#) is an example of this portion of the home page screen.

**Figure 13** Network storage router image



- The network storage router image is interactive, allowing quick access to configuration menus:
  - To display current settings and status for a port, click the corresponding port shown in the network storage router image.
  - To open a menu for making changes to the configuration for that particular port or bus, click the desired Fibre Channel port or SCSI bus.
  - To open the Network Configuration menu, click the Ethernet port.
- network storage router status information is located in the body of the home page and includes platform information.

- Main menu options:
  - **Home** displays network storage router status information.
  - **System** configures standard system components.
  - **Ports** configures the Fibre Channel port and SCSI buses.
  - **Discovery** displays devices and discovers new devices.
  - **Mapping** displays and configures maps.
  - **Statistics** displays network storage router statistics.
  - **Utilities** configures utility settings.
  - **Report** displays system information.
  - **Reboot** restarts the network storage router.

## System menu

The System menu is accessed from the Main menu and is used to view and configure serial, network, active fabric, user, real-time clock, and factory settings reset (see [Figure 14](#)).

**Figure 14** System screen

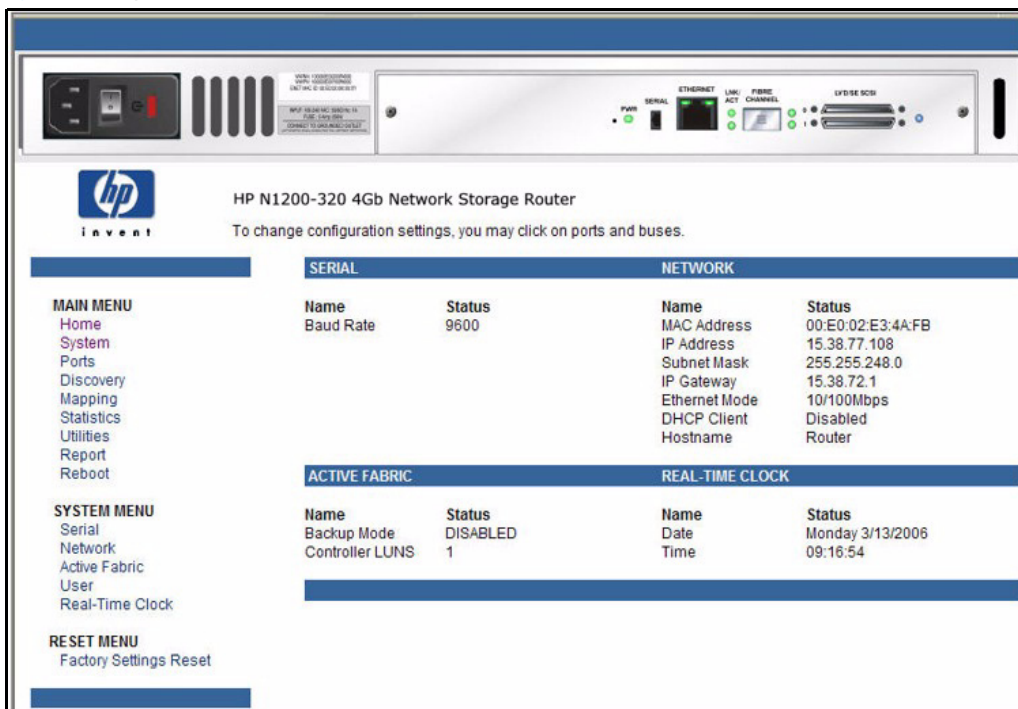

System menu:

- **Serial** configures the baud rate.
- **Network** configures Ethernet settings.
- **Active Fabric** configures Active Fabric settings.
- **User** configures user security settings such as the password.
- **Real-Time Clock** configures system date and time.

Reset menu:

- **Factory Settings Reset** restores factory default settings

## Serial configuration

The Serial screen is used to change the baud rate for the serial port (see [Figure 15](#)).

---

 **NOTE:** If the Autobaud feature is being used, it may not be necessary to set the baud rate.

---

**Figure 15** Serial screen

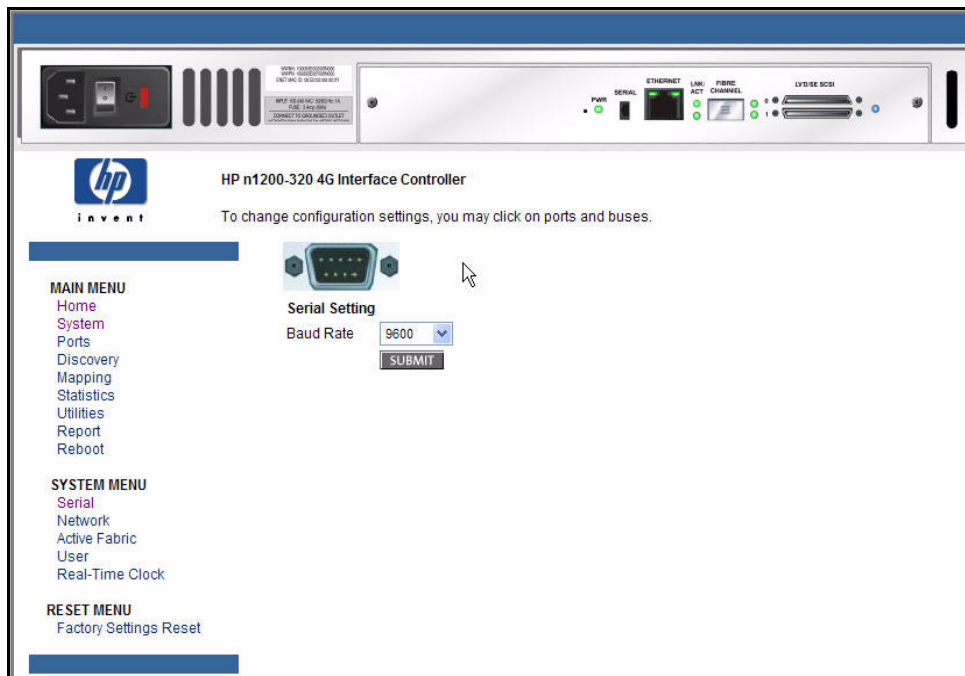

The current baud-rate setting is displayed.

Baud rate choices are:

- 9600
- 19200
- 38400
- 57600
- 115200

---

 **NOTE:** HP recommends setting the baud rate to 115200.

---

## Network configuration

The Network screen is used to enter Ethernet configuration settings (see [Figure 16](#)).

**Figure 16** Network screen

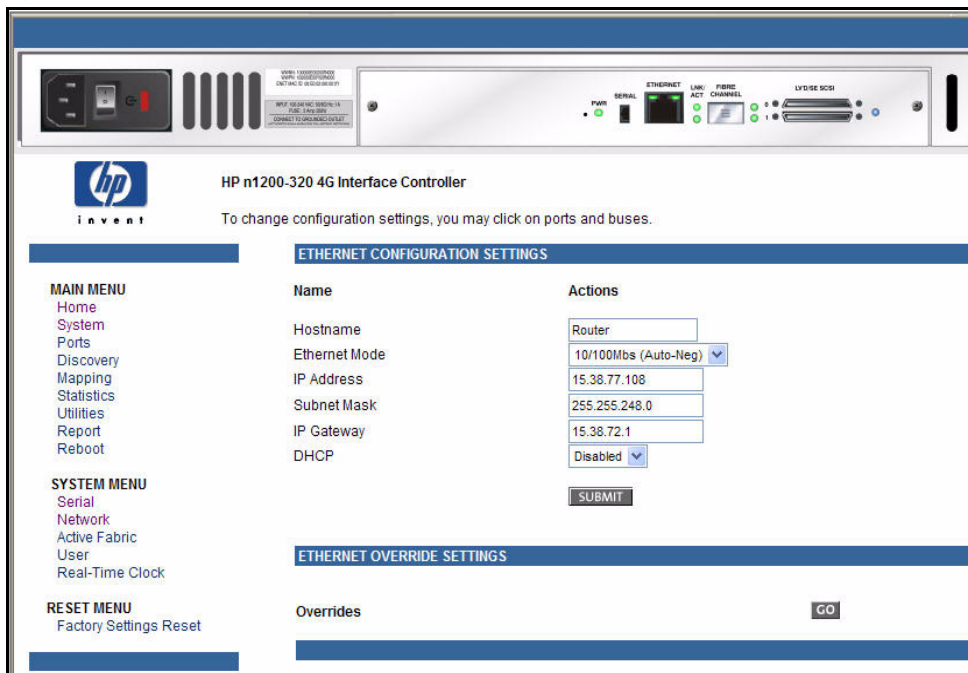

△ **CAUTION:** If this configuration is incorrectly set, processing difficulties may occur. Before changing this setting, evaluate the need for the change and verify the desired setting. HP recommends backing up the network storage router configuration to an external file before making changes to this setting.

Network menu options:

- **Host name** - to change the host name, enter an alphanumeric entry of one word, up to eight characters in length. Select **Submit**.
- **Ethernet Mode** - the Ethernet Mode can be set to one of the following options, though 10/100Mps (Auto-Neg.) is the default:
  - 10 Mps Only
  - 10/100Mps (Auto-Neg.) **Default**
  - 100Mps (half duplex) Only
  - 100Mps (full duplex) Only

📝 **NOTE:** The Ethernet physical address is assigned by DHCP by default.

- **IP Address** - is the IP address of the network storage router.
- **Subnet mask** - is the IP subnet mask for the network storage router.
- **IP Gateway** - is the IP address of the gateway for the Ethernet network connected to the network storage router.
- **DHCP** - enables or disables support for Dynamic Host Configuration Protocol (DHCP).
  - When DHCP is enabled, the network storage router requests a dynamic IP address from a DHCP server on the Ethernet network. The network storage router must be rebooted before an IP address is requested from the DHCP server. After the network storage router is rebooted, the HTTP session must be restarted. The IP address is different from the former non-DHCP IP address. You can now use the serial interface to obtain the new IP address (see ["Perform configuration"](#) on page 60).

---

 **NOTE:** To use the DHCP feature, a DHCP server must be operational on the Ethernet network. If the DHCP feature is used when there is not a DHCP server, the standard for DHCP requires the network storage router to wait three minutes for a response from a DHCP server before timing out.

---

Some DHCP servers allow an extended lease reservation to be set up for an IP address by providing the server with the Ethernet MAC address. The DHCP server always provides the same IP address to the network storage router. This setup can be useful for remote management of the network storage router via Telnet or VM. Because the method of setting up an extended lease reservation varies, depending on the DHCP server being used. Contact the Network Administrator for assistance.

## Active fabric configuration

The Active Fabric (AF) screen allows setup of a fibre target LUN for the network storage router (see Figure 17).

**Figure 17** Active Fabric screen

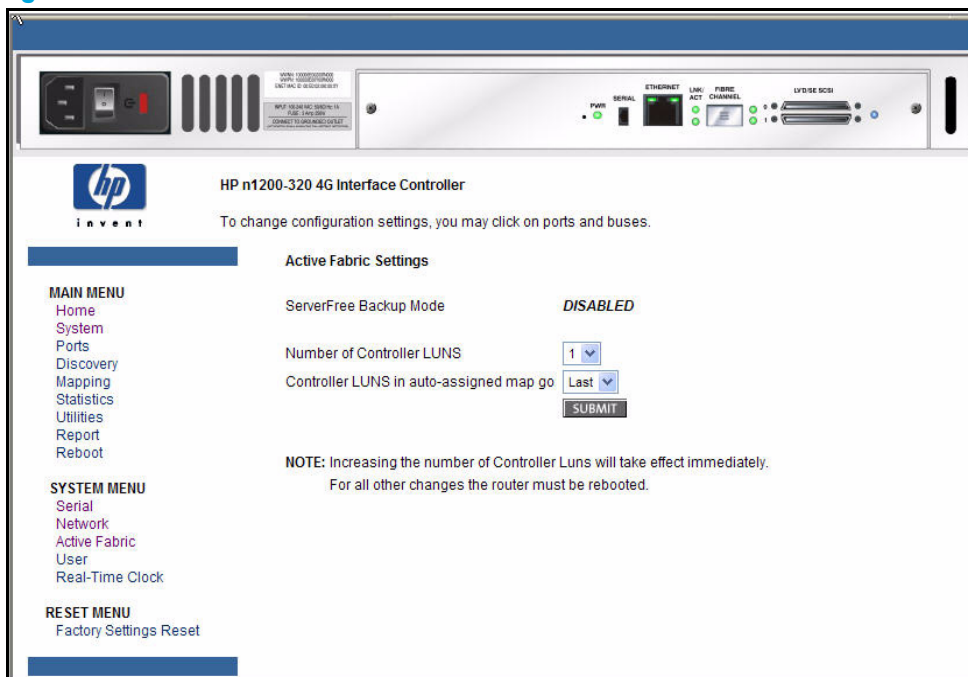

---

 **NOTE:** Increasing the number of Controller LUNS takes effect immediately. For all other changes, the network storage router must be rebooted.

---

Active Fabric settings:

- **ServerFree Backup Mode: NOT Supported**
- **Number of Controller LUNS:** (default: 1) sets the number of controller LUNs reported by the network storage router. The number must be in the range of 0 through 4.
- **Controller LUNS in auto-assigned map go:** settings are **First** or **Last**. Setting the choice to **Last** is recommended. Setting the choice to **First** can cause issues with HP-UX. However, if working with an **OVMS** host, it should be set to **First**.

## User security settings

### User name and password

The User screen is used to set up network storage router security such as the user name and password (see Figure 18).

**Figure 18** User screen

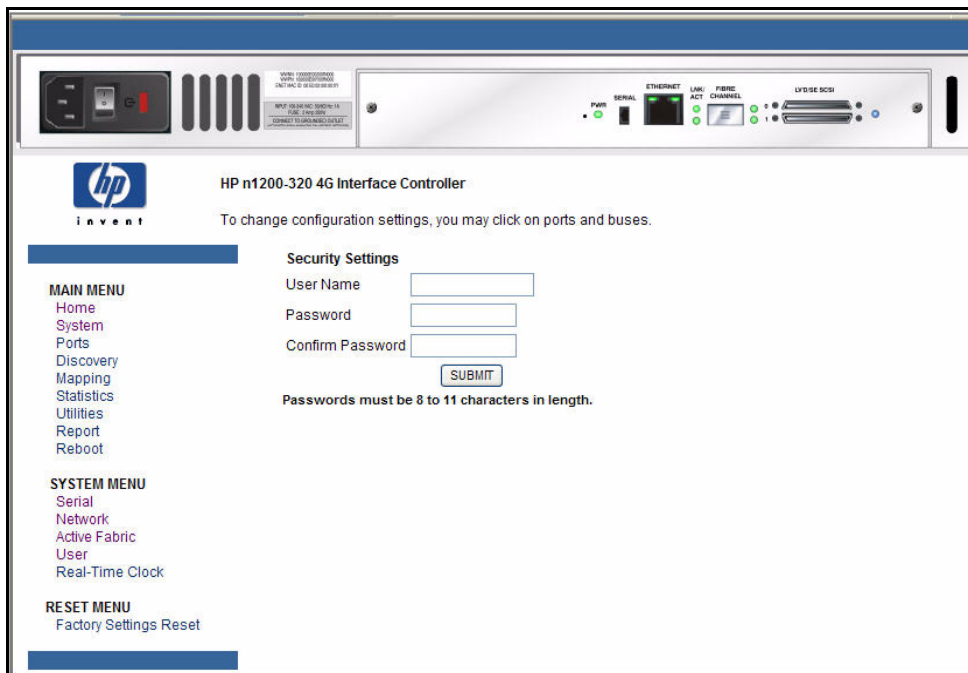

User settings:

- **User Name** (default: `root`) is any alphanumeric combination.
- **Password** (default: `password`) is any alphanumeric combination. Passwords must be 8 to 11 characters in length.
- **Confirm Password**

The user name and password should be unique and kept confidential. HP recommends using a combination of letters and numbers when creating the user name and password.

---

 **NOTE:** These security settings affect all user interfaces of the network storage router.

---

## Real-Time Clock configuration

The Real-Time Clock screen is used to set the system time and date (see [Figure 19](#)).

**Figure 19** Real-Time Clock screen

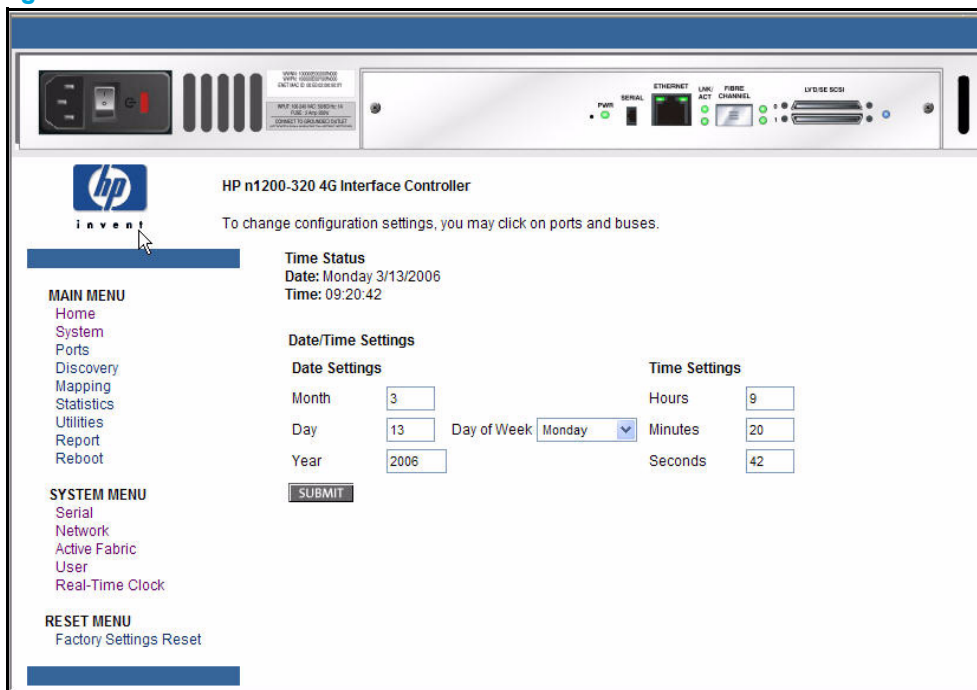

Date/time settings:

- **Date Settings** sets the month, day, and year (use a four-digit number to represent the year)
  - Day of Week sets the day of the week.
- **Time Settings** sets the hours, minutes, and seconds.

The system clock is a 24-hour clock. There is no a.m. or p.m. designation. Example 1:00 p.m. is 13 hours, 00 minutes.

## Reset menu

The Reset menu is used to reset the network storage router to factory default settings (see [Figure 20](#)).

**Figure 20** Reset to Factory Default screen

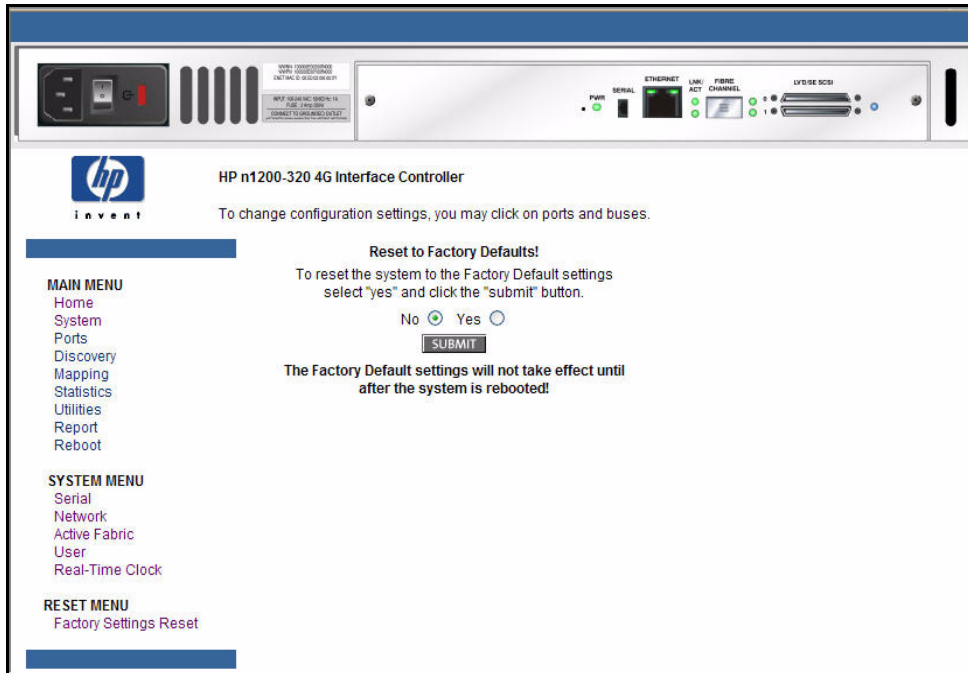

Current network storage router activities are disrupted while the unit resets the configuration to the factory defaults and saves those options to FLASH memory.

---

△ **CAUTION:** Resetting the network storage router configuration to the factory defaults deletes custom maps or map changes.

---

📄 **NOTE:** Resetting to factory defaults through VM does not affect Ethernet connectivity. User-configured values for the IP address and gateway are retained.

---



## Ports menu

Accessed from the Main menu, the Ports menu is used to view and to modify configuration settings of the Fibre Channel port and SCSI buses (see [Figure 21](#)).

**Figure 21** Ports menu

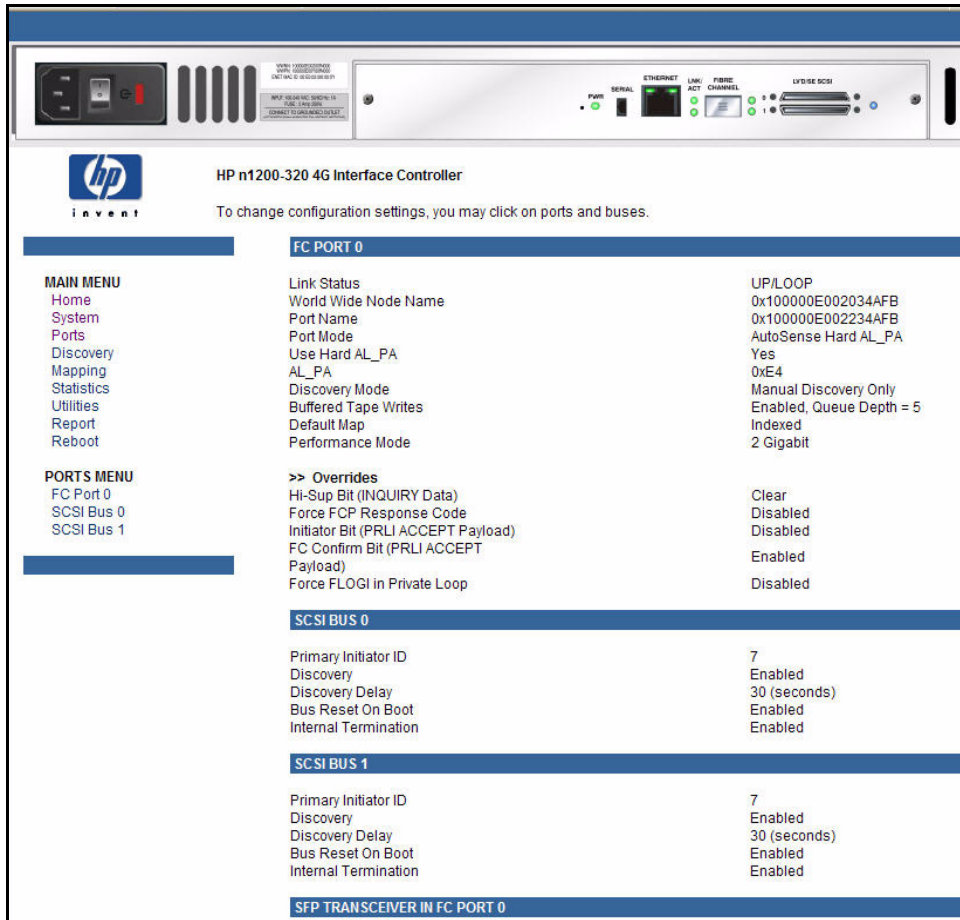

The initial screen display of the Ports menu includes summary information about each Fibre Channel port and SCSI bus in the network storage router.

Ports menu tasks:

- **Fibre Channel Port 0** configuration changes the Fibre Channel port settings.
- **SCSI Bus 0, 1** configuration changes SCSI bus settings.

Each Ports menu option is discussed in the following subsections.

To view or make changes to a specific port or bus:

1. Select the port or bus from the menu bar on the left side of the screen or select the port or bus from the network storage router image at the top of the screen.
2. Modify the setting.
3. Click **Submit**.

## Fibre Channel port configuration

When the Fibre Channel port is selected in Ports menu, the Fibre Channel Configuration screen is displayed (see Figure 22).

**Figure 22** Fibre Channel port 0 configuration settings screen

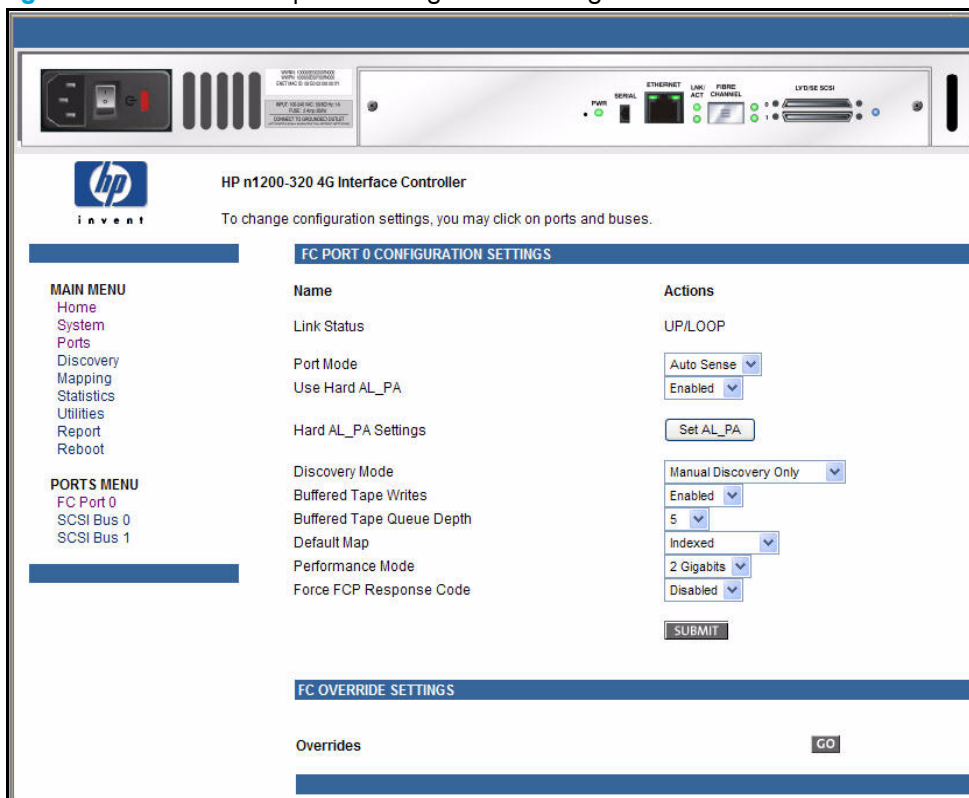

Fibre Channel port settings:

- **Link Status** indicates the port link status.
- **Port Mode** (default: N\_Port) sets the port mode.

Port Mode settings:

- **Auto Sense:** In this mode, the Fibre Channel port tries to negotiate as a loop. If it is not successful, then the Fibre Channel port negotiates as a fabric. If the port comes up as a loop, it then determines whether it is on a private or public loop.
- **N\_Port:** (default) This mode allows the network storage router to bypass the loop negotiation and come up as a fabric only. If the network storage router is on a loop, and N\_Port mode is selected, an error in communication may occur.
- **Use Hard AL\_PA** enables or disables Hard AL\_PA usage.
- **Hard AL\_PA Settings** displays the AL\_PA Lookup Table.

Use the table to find the node number. This unique one-byte valid value (derived from an Arbitrated Loop Topology defined in ANSI specification FC\_AL version 4.5) is used for the Fibre Channel configuration.

- **Discovery Mode** (default: Manual Discovery Only) determines how the network storage router discovers new Fibre Channel devices.

Discovery mode settings:

- **Auto Discovery on Reboot** allows the network storage router to automatically discover all Fibre Channel devices when rebooted or when link-up events occur, such as connecting cables or rebooting network hubs.
  - Both the ports and the devices behind the ports are discovered on all subsequent link-up events.

- **Discovery on Link Up** allows the network storage router to automatically discover all Fibre Channel devices when rebooted or when link-up events occur, such as connecting cables or rebooting network hubs.
  - Both the ports and the devices behind the ports are discovered for the first link-up event. Subsequent link-up events only discover the ports and not the devices behind the ports.
- **Manual Discovery Only** (default) sets discovery of new devices to occur only after the user selects the **Discovery** option from the Main menu or when a Registered State Change Notification (RSCN) is received from a fabric.
- **Buffered Tape Writes** (default: enabled) enables or disables the Buffered Tape Write option.

---

△ **CAUTION:** If this configuration setting is incorrectly set, processing difficulties may occur. Before changing this setting, evaluate the need for the change and verify the desired setting. HP recommends backing up the network storage router configuration to an external file before making changes to this setting.

---

When enabled, to enhance performance, Buffered Tape Writes return status on consecutive write commands prior to the tape device receiving data.

- **Buffered Tape Queue Depth** sets the Buffered Tape Queue Depth. Select a setting of 0 through 10 from the drop-down list.
- **Default Map** (default: indexed) sets the current mapping mode for the selected port. The current map can be set to:
  - **Indexed** (default) (HP recommends that this map NOT be edited, even though the user is able to edit the Indexed map.)
  - **Auto-assigned** contains all the SCSI devices that are attached to the network storage router.
  - **SCC**
- **Performance Mode** (default: 4 Gb/s) toggles between 1 Gb/s, 2 Gb/s, and 4 Gb/s.

---

 **NOTE:** If Performance Mode is set incorrectly and the network storage router is plugged into a Loop or Fabric, the unit will not light the LNK LED and may receive Framing errors due to the incorrect Fibre Channel link speed.

---

- **Force FCP Response Code** toggles between Disabled and Enabled for support of HP-specific HBAs.

## SCSI bus configuration

When a SCSI bus is selected in the Ports menu, the SCSI Bus Configuration screen is displayed (see Figure 23).

**Figure 23** SCSI Bus 0, 1 configuration screens

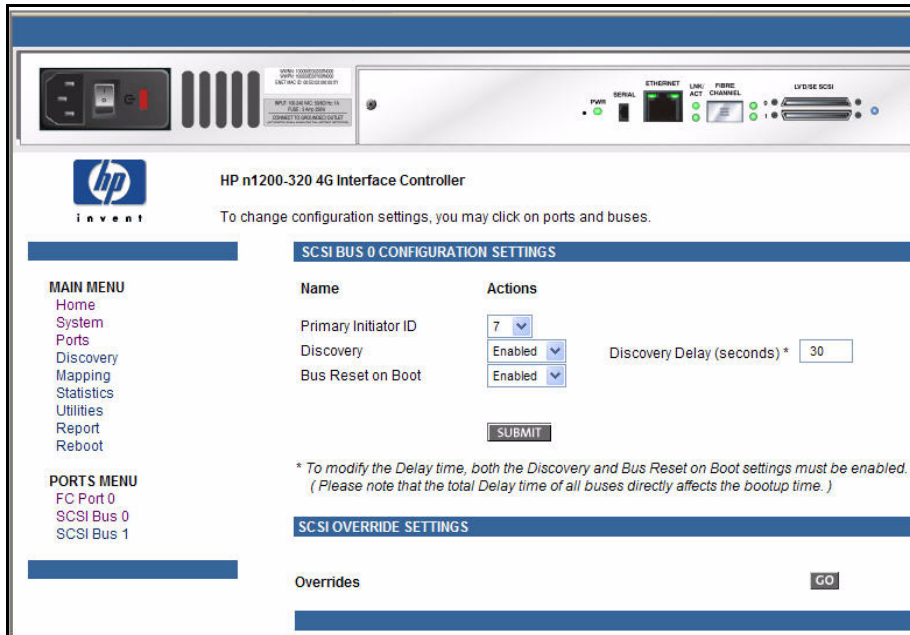

SCSI bus configuration settings:

- **Primary Initiator ID** (default: 7) must be a unique ID.
- **Discovery** toggles between Enabled and Disabled, **Enabled** by default.
- **Bus Reset on Boot** toggles between Enabled and Disabled.

When enabled, the network storage router automatically resets SCSI buses during a power-up or reboot of the library.

- **Discovery Delay** is the wait time after a power-up or reboot before discovering SCSI devices. HP recommends setting the value to at least 30 seconds to ensure that all SCSI devices complete their individual power-ups.
- **SCSI Override Settings**
  - Overrides

# Discovery menu

Accessed from the Main menu, the Discovery menu is used to view existing, and discover new Target devices (see Figure 24).

**Figure 24** Discovery screen

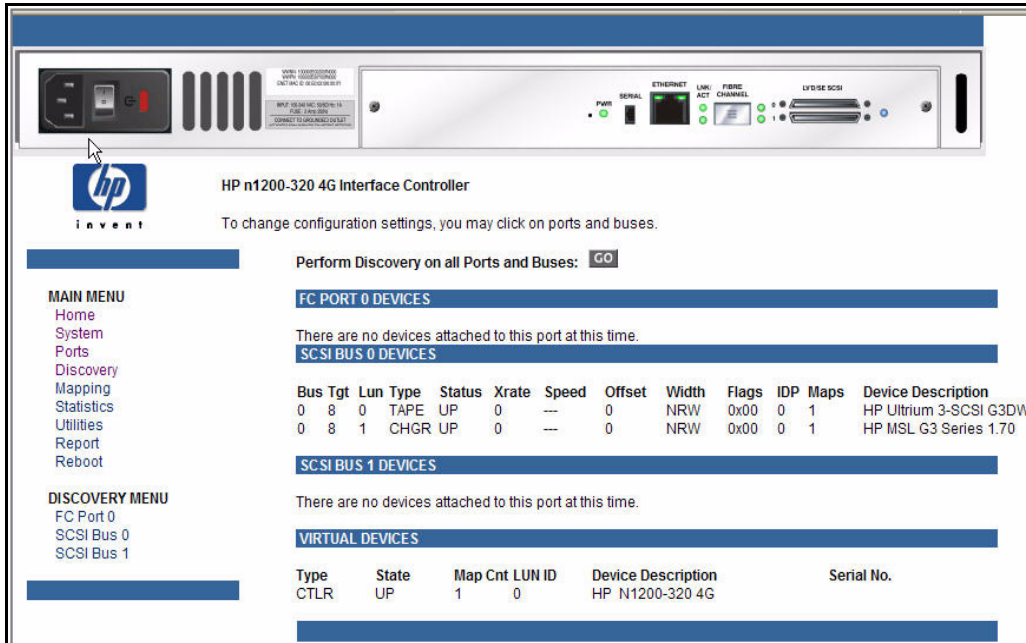

To perform a manual discovery:

1. Select the Fibre Channel port or SCSI bus from the menu bar or the network storage router image.
2. Select **Go**.

**Figure 25** Perform discovery on FC Port 0 screen

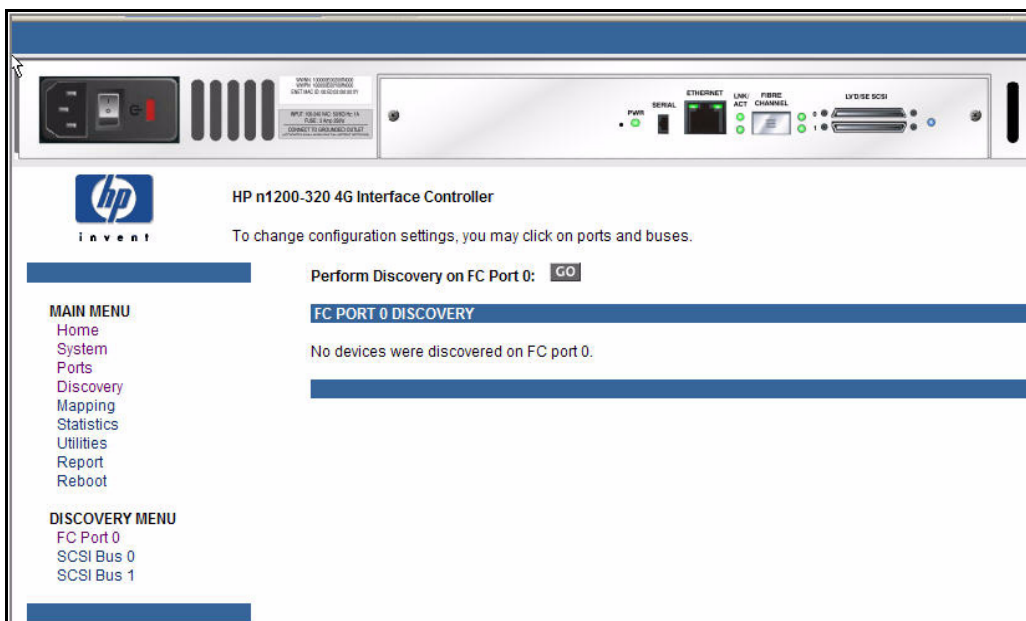
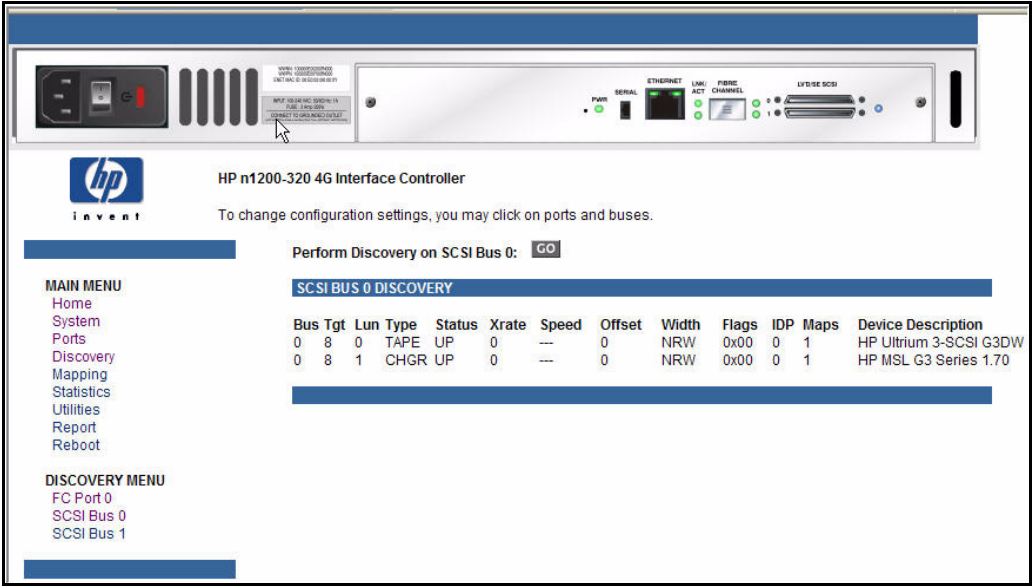

Figure 26 Perform discovery on SCSI Bus 0 screen



## Mapping menu

Accessed from the Main menu, the Mapping menu is used to create or edit LUN maps and assign them to hosts. (see [Figure 27](#)).

**Figure 27** Mapping screen

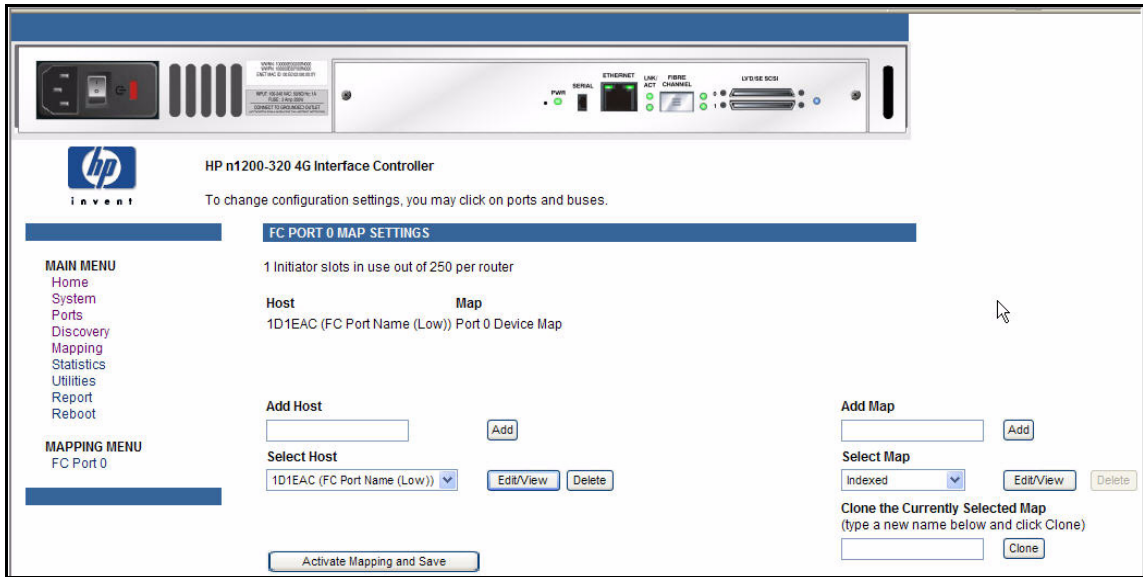

**NOTE:** Indexed, Auto Assigned, and SCC maps cannot be deleted or renamed.

**NOTE:** SCC and Auto-Assigned maps cannot be cloned.

Each physical port/bus on the network storage router can have the following maps:

**Table 4** Device map types

Map type	Generated by	Editable
Auto Assigned	System	No
Indexed ( <b>default</b> )	System	Yes
Port 0 Device Map	System Generated/User Edited	Yes
SCC	System	No

Each map has a unique name and map ID; one of the maps must be identified as the **current** map.

## Fibre Channel mapping tasks

Configuration tasks for Fibre Channel mapping includes:

- Viewing and changing Fibre Channel map information
- Viewing and changing Fibre Channel host information

Each task is discussed in the following paragraphs.

## Viewing and changing Fibre Channel map information

---

 **NOTE:** **Port 0 Device Map** is the HP recommended map to be used for editing and assigning to hosts that communicate with the library. The Indexed (default) map should not be used for editing, even though the user is able to edit this map.

---

To view or change current Fibre Channel map information:

1. In the Mapping menu screen, select the desired map.
  2. Select **Edit/View** in the Map section of the screen.  
The Fibre Channel Map dialog box is displayed. Current map information is shown at the top of the dialog box.
  3. Enter the new settings and then select the appropriate action button.
- 

 **NOTE:** Bus/Target mapping mode is recommended.

---

 **NOTE:** SCSI devices attached to a Fibre Channel must be mapped as sequential Fibre Channel LUNs starting at LUN number 00. Skipping LUN numbers is not recommended when mapping Fibre Channel LUNs because Fibre Channel Discovery stops the discovery process whenever an empty LUN position is found.

---

 **NOTE:** Auto-Assigned and SCC maps cannot be modified, cleared, filled, or have entries removed.

---

 **NOTE:** Map settings are saved to memory when any button within the page is selected.

---

## Viewing and changing Fibre Channel host information

---

 **NOTE:** HP recommends setting the **Index** map as the default and allowing it to remain empty, while filling a custom map (such as **Port 0 Device Map**) with only the hosts that need to communicate with the library or drives.

---

To view or change current host information:

1. In the Mapping menu screen, select the desired map.
2. Click **Edit/View** in the Host section of the screen.  
The Fibre Channel Host Name dialog box is displayed. Current host information is shown at the top of the dialog box.
3. Enter the new map settings and then select **Modify**.

Fibre Channel Host Name settings:

- **Host Name**
- **Host ID** (hexadecimal)
- **Port WWN Hi** (hexadecimal) (service mode-restricted access)
- **Port WWN Lo** (hexadecimal) (service mode-restricted access)
- **Node WWN Hi** (hexadecimal) (service mode-restricted access)
- **Node WWN Lo** (hexadecimal) (service mode-restricted access)
- **Map Name**



## Statistics menu

Accessed from the Main menu, the Statistics menu is used to display Fibre Channel port and SCSI bus information (see Figure 28).

Figure 28 Statistics menu

The screenshot displays the HP n1200-320 4G Interface Controller web interface. At the top, there is a hardware status bar with icons for Power, Serial, Ethernet, Link, Fibre Channel, and LVD/SCSI. Below this is the HP logo and the text "HP n1200-320 4G Interface Controller". A navigation menu on the left includes: Home, System, Ports, Discovery, Mapping, Statistics, Utilities, Report, and Reboot. The main content area is titled "FC PORT 0 STATISTICS" and contains a table of statistics:

Statistic	Value
In Device Data Sequences	0x00000082
Out Device Data Sequences	0x00000041
In Link Data Sequences	0x0000006C
Out Link Data Sequences	0x0000006C
In PBSY Frames	0x00000000
Out PBSY Frames	0x00000000
In FBSY Frames	0x00000000
In PRJT Frames	0x00000000
Out PRJT Frames	0x00000000
FC Link Down	0x00000001
In Aborts	0x00000000
Out Aborts	0x00000000
Laser Faults	0x00000000
LOS	0x000000C7
Sync	0x00000002
Bad Rx Characters	0x000000FF
Link Failures	0x00000004
Bad CRCs	0x00000000
Protocol Errors	0x00000000
Bad SCSI Frames	0x00000000

Below the table is a "Reset FC & SCSI System Statistics: GO" button. Underneath, there are sections for "SCSI BUS 0 STATISTICS" and "SCSI BUS 1 STATISTICS", both showing "Mode" as "LVD" and "Resets" as "0".

To view information for a specific port or bus, click the component on the menu bar or the network storage router image. To refresh the display, select **Reset FC & SCSI System Statistics**.

## Utilities menu

Accessed from the Main menu, the Utilities menu is used to view and configure utility options (see Figure 29).

Figure 29 Utilities menu

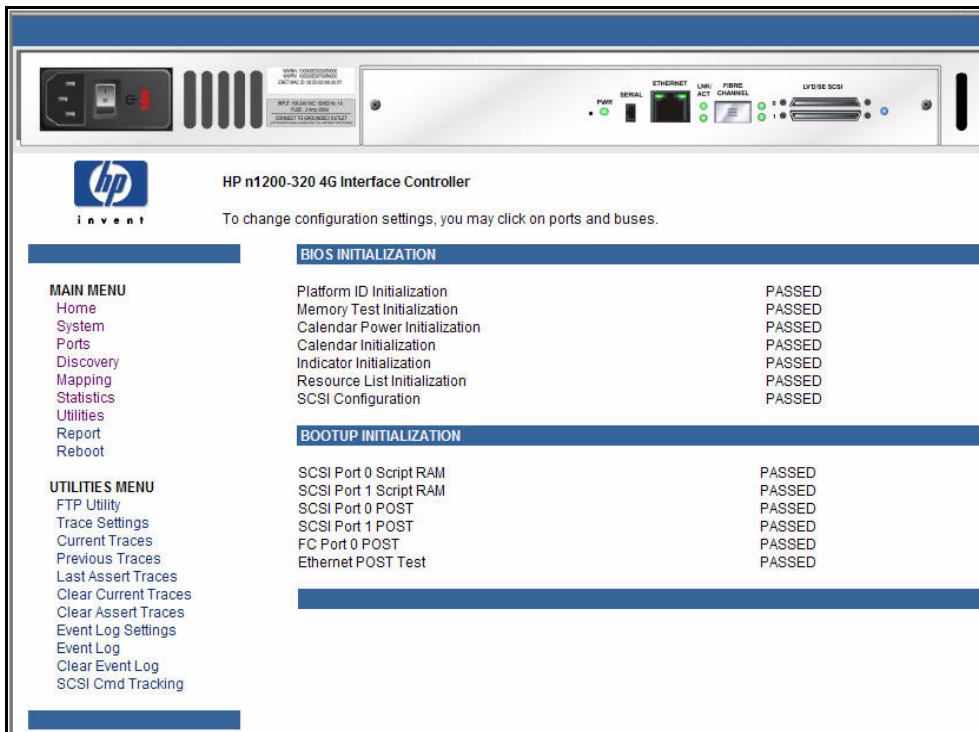

Utilities menu tasks:

- **FTP Utility** opens an FTP session.
- **Trace Settings** configures trace settings.
- **Current Traces** displays current trace information.
- **Previous Traces** displays previous trace information.
- **Last Assert Traces** displays last assert trace information.
- **Clear Current Traces** clears current trace information.
- **Clear Assert Traces** clear current trace information.
- **Event Log Settings** configures Event Log settings.
- **Event Log** displays the Event Log.
- **Clear Event Log** clears the Event Log.
- **SCSI Command Tracking**

Each Utilities menu option is discussed in the following sections.

## FTP utility access

The FTP utility screen is used to open an FTP session (see [Figure 30](#)).

**Figure 30** FTP Utility screen

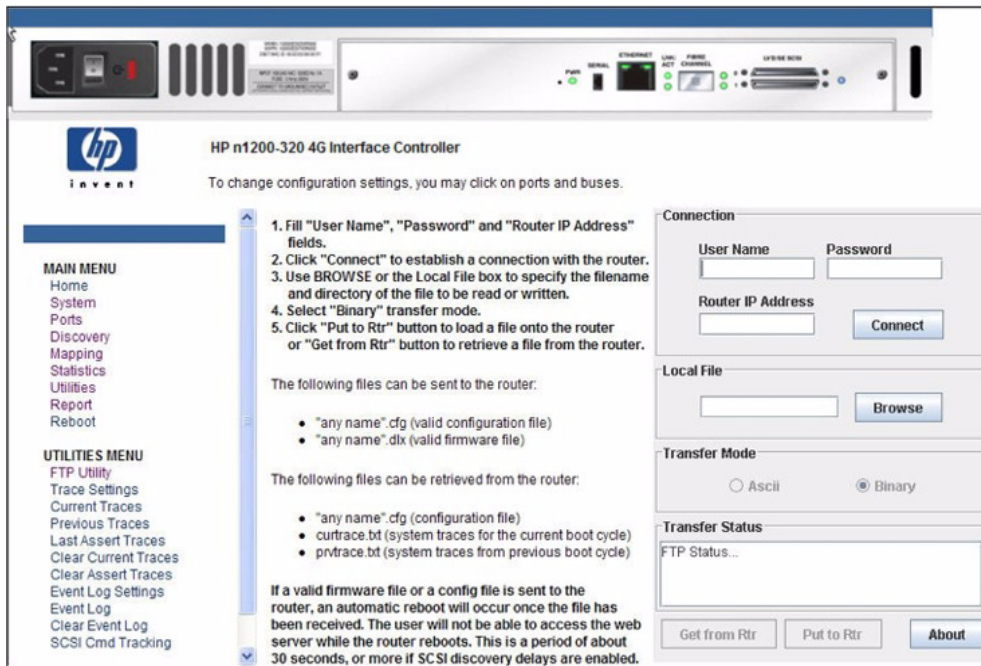

The FTP utility requires the use of a JAVA applet and prompts for permission to install the applet, if needed. If the prompt is displayed, follow the on screen instructions to complete the installation. The FTP utility then prompts for permission to run the applet.

**NOTE:** Internet access is required to verify the signature for the HP FTP applet and to download the JAVA applet plug-in for your browser.

To open an FTP session:

1. Enter the User Name, Password, and the IP address of the network storage router.
2. Click **Connect**.
3. Select the local file to upload or download. If necessary, click **Browse** to scroll through a file list.

The following file types can be uploaded to the network storage router:

- Configuration (.cfg)
- Firmware (.dlx)

The following file types can be downloaded from the network storage router:

- Configuration (.cfg)
- Traces for the current boot cycle (curtrace.txt)
- Traces from the previous boot cycle (prvtrace.txt)

4. Click **Binary** Transfer mode.
5. Choose the desired task:
  - To download a file, click **Get**.
  - To upload a file, click **Put**.

**NOTE:** If a valid firmware or configuration file is uploaded to the network storage router, an automatic reboot occurs once the file has been received. The network storage router cannot be accessed from the Visual Manager UI during the time that the reboot is in process, which is approximately 30 seconds.

## Trace settings configuration

This menu allows the configuration of Trace Settings (see [Figure 31](#)).

**Figure 31** Trace settings configurations screen

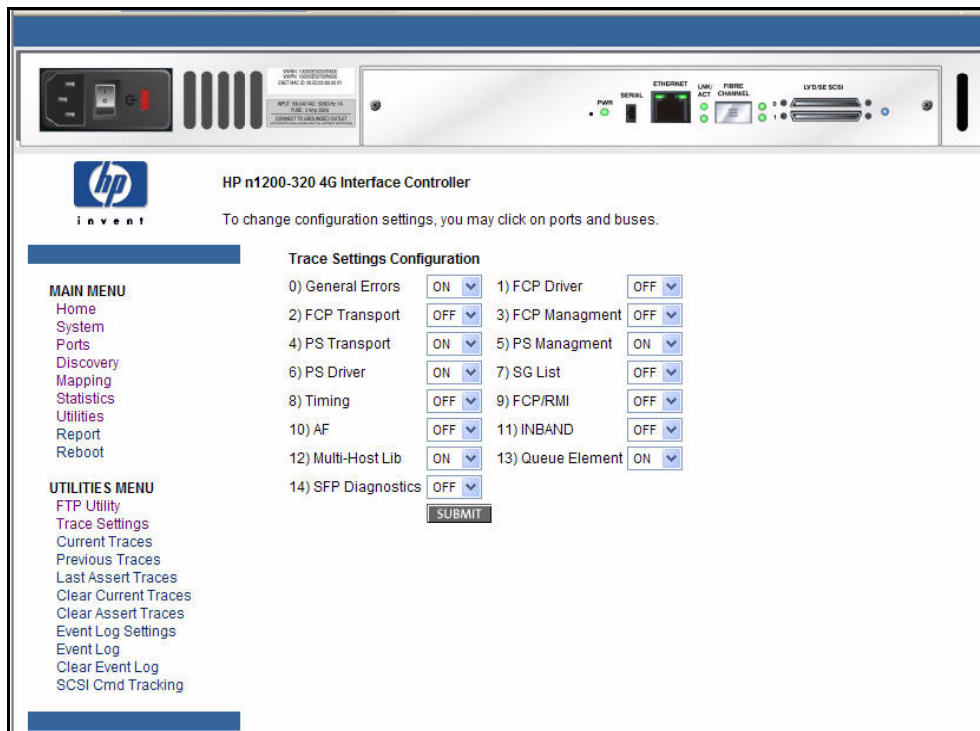

To change the settings, use the drop-down boxes and choose the desired setting. After all changes are completed, select **Submit**. [Table 5](#) is a brief description list of the trace settings.

**Table 5** Trace Settings

Setting	Description
General Errors	Displays the most serious error and exception conditions
FCP Transport	Fibre Channel Protocol transport functionality is monitored and recorded
PS Transport	Parallel SCSI transport functionality is monitored and recorded
PS Driver	Parallel SCSI driver functionality is monitored and recorded
Timing	Timer functions are monitored and recorded
AF	Active Fabric firmware is monitored and recorded
Multi-Host Lib	Debugging capability for Multi-host library features
SFP Diagnostics	Optical transceiver status is monitored and recorded
FCP Driver	Fibre Channel Protocol driver functionality is monitored and recorded
FCP Management	Fibre Channel Protocol management functionality is monitored and recorded
PS Management	Parallel SCSI functionality is monitored and recorded
SG List	Scatter/gather list is monitored and recorded
FCP/RMI	Fibre Channel Protocol routing layer is monitored and recorded

**Table 5** Trace Settings

Setting	Description
INBAND	Controller management functionality is monitored and recorded
Queue Element	Debugging capability for specific network storage router resources

## Current, previous, and last assert trace displays

These three Utilities menu screens show trace information.

- The Current Traces screen shows data since the network storage router was last booted.
- The Previous Traces screen shows data from the last boot cycle.
- The Last Assert Traces screen shows data since the last assertion.

Trace buffers can be cleared by selecting either the **Clear Current Traces** option or the **Clear Assert Traces** option.

## Clear current trace buffer or assert trace buffer

Trace buffers can be cleared by selecting either the **Clear Current Traces** option or the **Clear Assert Traces** option. When the Clear Current Traces option is selected, a confirmation message appears to verify the selection. If a response of Yes is given, the unit clears the current trace buffer. Current network storage router activities are not disrupted while the buffer is cleared. Select the **Submit** button to finalize your choice.

## Event log settings

The Event Log Settings screen is used to configure Event Log filters (see [Figure 32](#)).

**Figure 32** Event Log settings screen

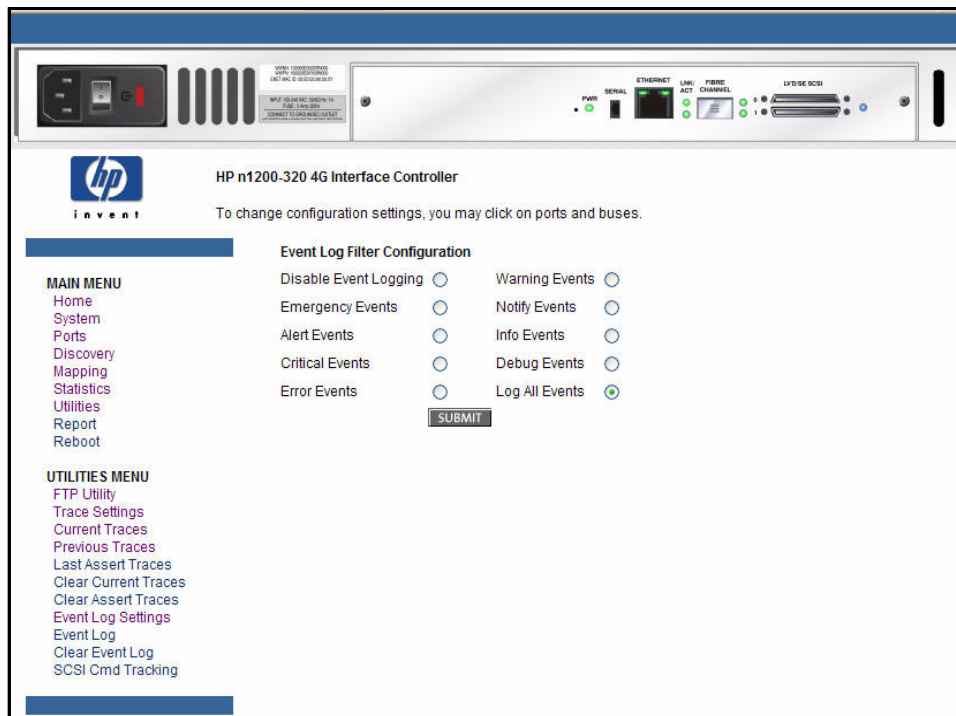

Event Log settings:

- Disable/Enable Logging
- Emergency Events
- Alert Events
- Critical Events
- Error Events

- Warning Events
- Notify Events
- Info Events
- Debug Events
- Log All Events

Event logging captures the last 215 events and then starts overwriting the log.

**NOTE:** To correlate event logging, correctly set the clock and date in the Real-Time Clock configuration menu (see "Real-Time Clock configuration" on page 39).

## Event log display

The Event Log screen is used to view the Event Log (see Figure 33).

**Figure 33** Event log display

HP n1200-320 4G Interface Controller  
To change configuration settings, you may click on ports and buses.

**Event Log Display**

**MAIN MENU**  
Home  
System  
Ports  
Discovery  
Mapping  
Statistics  
Utilities  
Report  
Reboot

**UTILITIES MENU**  
FTP Utility  
Trace Settings  
Current Traces  
Previous Traces  
Last Assert Traces  
Clear Current Traces  
Clear Assert Traces  
Event Log Settings  
Event Log  
Clear Event Log  
SCSI Cmd Tracking

Num	Date/Time	sysUpTime	Message
1.	03/14/2006 08:54:43	0d00h16m13.95s	Event log erased by Operator
2.	03/22/2006 13:24:28	11d11h20m39.95s	Firmware image 5.7.1adw2 Version 5.7 received and stored to flash
3.	03/22/2006 13:27:01	0d00h00m00.00s	New device is added to location 0/0/0
4.	03/22/2006 13:27:01	0d00h00m49.20s	New device is added to location 0/1/0
5.	03/22/2006 13:27:01	0d00h00m49.20s	New device is added to location 1/2/0
6.	03/22/2006 13:27:01	0d00h00m49.26s	Unit restart and initialization, Firmware Version: 5.7 Build Level: 5.7.1adw2
7.	03/22/2006 13:27:02	0d00h00m50.48s	FC Port 0 Link is UP
8.	03/23/2006 10:45:38	1d05h49m42.70s	Firmware image 5.7.1b Version 5.7 received and stored to flash
9.	03/23/2006 10:48:11	0d00h00m00.00s	New device is added to location 0/0/0
10.	03/23/2006 10:48:11	0d00h00m49.20s	New device is added to location 0/1/0
11.	03/23/2006 10:48:11	0d00h00m49.20s	New device is added to location 1/2/0
12.	03/23/2006 10:48:12	0d00h00m49.25s	Unit restart and initialization, Firmware Version: 5.7 Build Level: 5.7.1b
13.	03/23/2006 10:48:12	0d00h00m50.50s	FC Port 0 Link is UP.
14.	03/27/2006 10:08:29	5d13h29m14.50s	CHK COND with Sense Key=0x4, ASC=0x8, ASCQ=0x0 from SCSI LUN 0/1/0
15.	03/27/2006 10:08:30	5d13h29m15.15s	CHK COND with Sense Key=0x4, ASC=0x8, ASCQ=0x0 from SCSI LUN 1/2/0
16.	03/27/2006 10:08:30	5d13h29m15.55s	CHK COND with Sense Key=0x4, ASC=0x8, ASCQ=0x0 from SCSI LUN 0/0/0
17.	03/27/2006 10:09:06	5d13h30m06.26s	Reboot requested via main serial menu
18.	03/27/2006 10:09:06	5d13h30m06.26s	FC Port 0 Link is DOWN.
19.	03/27/2006 10:11:35	0d00h00m00.00s	Unit restart and initialization, Firmware Version: 5.7 Build Level: 5.7.1b
20.	03/27/2006 10:11:36	0d00h00m50.45s	FC Port 0 Link is UP.
21.	03/29/2006 08:53:34	0d00h00m00.00s	New device is added to location 0/0/0



## Clear event log

The Clear Event Log screen is used to clear the Event Log (see [Figure 34](#)). Current network storage router activities are not disrupted.

**Figure 34** Clear event log screen

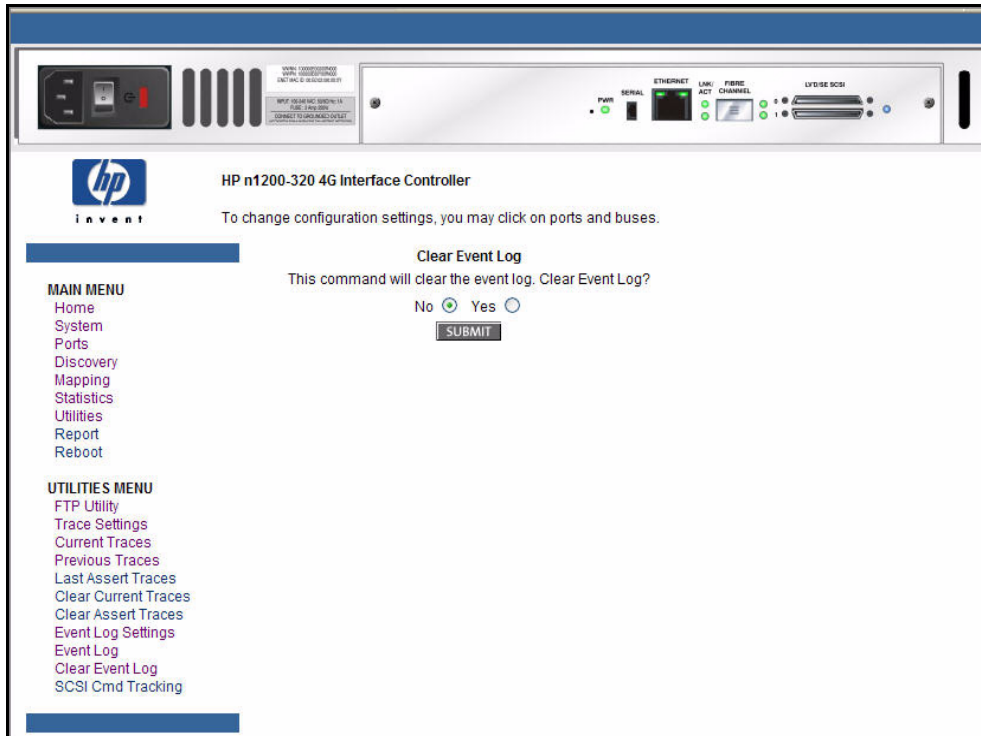

## SCSI command tracking

This menu provides options for setting up and logging SCSI commands that are received or transmitted by the network storage router. Results are displayed in the Host/Device ID Table (see [Figure 35](#)).

**Figure 35** SCSI command tracking

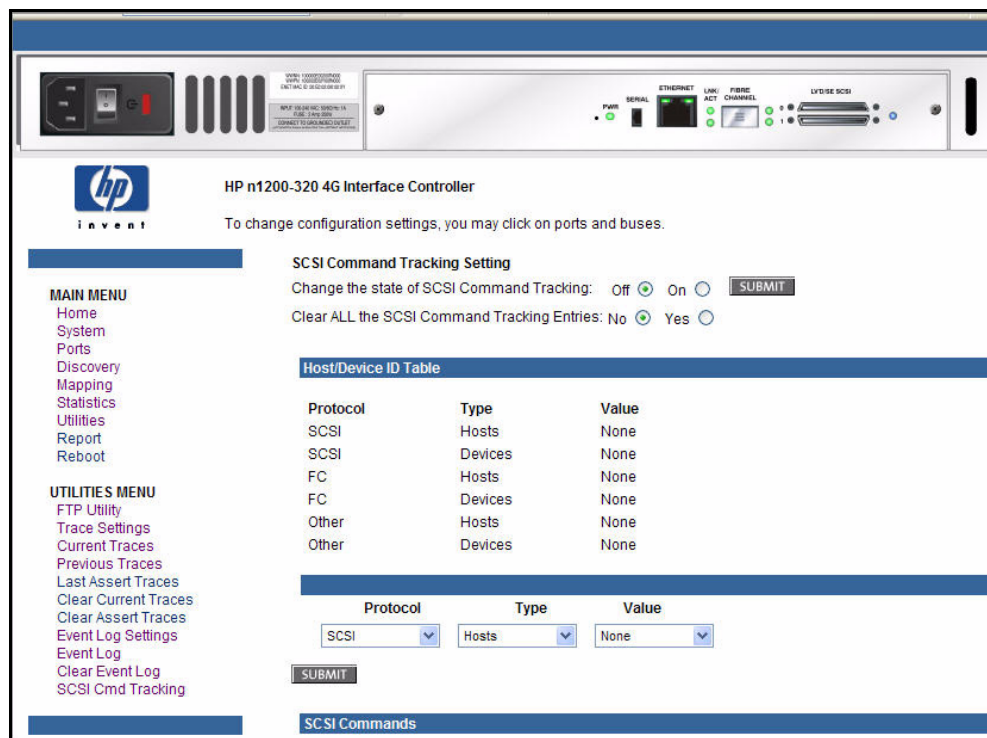

While the network storage router's current, previous, and last assert trace data does provide a complete summary of events in a chronological fashion, SCSI Command Tracking adds the ability to filter the trace data to show only the information related to the processing of specific SCSI commands.

- SCSI Command Tracking can be toggled to **ON** or **OFF**. When toggled **ON** and submitted, all SCSI commands received or transmitted to or from the network storage router are then logged in the SCSI Commands section shown on this screen. When set to **OFF** (and submitted), no SCSI commands are logged.
- Previous entries for SCSI Command Tracking can also be cleared. Toggling the clear option to the **ON** position and selecting the **Submit** button clears all previous entries.
- The settings for the Host/Device ID Table are used to filter the trace data such that a sub-set of the total logged information is displayed under the SCSI Commands section. Logged data can be defined according to the Protocol (FC, Other, or ALL), Type (Device, Host, or ALL), and Value (ID or ALL). For the ID, this can be a specific FC LUN or Switch ID (S\_ID) or some other specific value. Selecting the **Submit** button activates the settings for Protocol, Type, and Value.

## Report menu

Accessed from the Main menu, when Report is selected, a second window pops up and displays a consolidated view of the following:

- Platform
- BIOS Initialization
- Bootup Initialization
- Serial
- Ethernet
- FC Port 0
- SFP Transceiver in FC Port 0
- SCSI Bus 0
- SCSI Bus 1
- Discovery Information
- Device Entries
- Mapping Information
- Active Initiators
- Trace Settings
- Current Traces
- Previous Traces
- Assert Traces
- Event Log Settings
- Event Log



# Reboot option

△ **CAUTION:** Confirm there is no activity, such as a backup in progress, before initiating a reboot because network storage router activities will be disrupted.

Network storage router reboots are executed using this Main menu option (see [Figure 36](#)).

When the library is rebooted, current network storage router activities are disrupted. All submitted configuration changes are activated during the boot-up process.

**Figure 36** Reboot screen

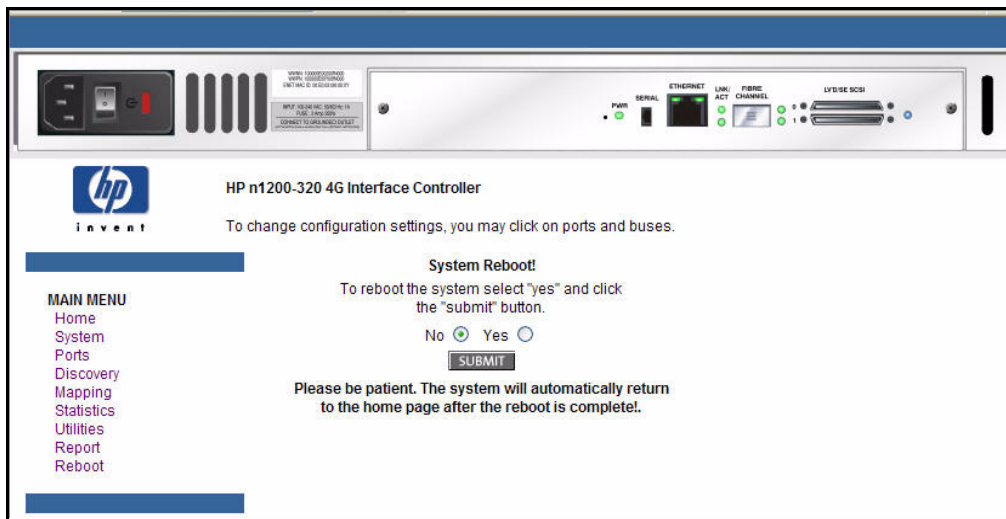

The system automatically returns to the home page after the reboot has completed.



## 6 Using the Command Line Interface

This chapter describes specific configuration options available from the perspective of the Command Line Interface (CLI). For an overview of using the other configuration methods available, see “[N1200-320 4Gb Network Storage Router management](#)” on page 27.

The network storage router allows the user to access many configuration settings through the Command Line Interface. Among these settings are:

- Serial, Ethernet, and fibre port configuration
- Fibre LUN mapping
- Assigning LUN maps to hosts
- Trace level settings

All of the above settings may be changed and saved.

 **NOTE:** Unless otherwise indicated, configuration changes take effect when the system next powers on or reboots.

### Power-up messages

When the HP N1200-320 4Gb Network Storage Router powers on, a series of power-up messages appear on the terminal or terminal emulation program for the serial port or the Telnet utility for Telnet sessions.

A series of power-up self tests are performed as the network storage router starts (which can take up to 90 seconds), and messages related to these tests are visible from the serial port. If completed successfully, the main menu appears, as shown in [Figure 37](#).

 **NOTE:** The illustrations in this chapter use **Xs** to represent numeric values for certain data fields, such as the product release version and the revision of firmware.

 **NOTE:** For the serial port, if you do not see messages over the Command Line Interface, you may need to re-check your computer’s serial port settings.

The main menu appears as follows:

**Figure 37** Main menu

```
HP StorageWorks N1200-320 4Gb Network Storage Router
X.XX.XX XXXXXX XXXXXXXXXXXXXXXXXXXX
07/7/2005 18:37:08

1) Perform Configuration
2) System Utilities
3) Display Trace and Assertion History
4) Reboot
5) Download a New Revision of The Firmware

Command >
```

The main menu allows for various operations to be performed on the network storage router.

- Select **1** to access network storage router configuration settings.
- Select **2** to access System Utilities.
- Select **3** to display trace and assertion history.
- Select **4** to reboot the network storage router. A confirmation message appears to verify this action.
  - Enter **N** to return to the System Utilities menu.
  - Enter **Y** to restart the network storage router.
- Select **5** to download a new revision of the firmware. A confirmation message appears to verify this action. (For additional information see "[Download a new revision of the firmware](#)" on page 90.)
  - Enter **N** to return to the Main menu.
  - Enter **Y** for the network storage router to accept firmware data from the serial port.

## Perform configuration

The Perform Configuration menu allows the administrator to configure the various options on the network storage router. For most configuration changes to take effect, you must reboot the network storage router.

---

 **NOTE:** Menus are not case sensitive. You can enter uppercase and lowercase characters interchangeably, whenever menus indicate letters as choices.

---

**Figure 38** Configuration menu

```
Configuration Menu
X.XX.XX  XXXXXX  XXXXXXXXXXXXXXXXXXXX
07/7/2005  08:56:22

1) Baud Rate Configuration
2) Ethernet Configuration
3) Fibre Channel Configuration
4) Parallel SCSI Configuration
5) Device Mapping
6) Trace and Event Settings Configuration
7) Real-Time Clock Configuration
8) Active Fabric Configuration

A) Save Configuration
B) Restore Last Saved Configuration
C) Reset to Factory Defaults

X) Return to main menu
```

## Baud rate configuration

This menu changes the baud rate used on the serial port. Select **1** through **5** for the appropriate baud rate setting. If you are using the Autobaud feature, it may not be necessary to set a baud rate. See "Autobaud feature" on page 21 for more information on using the Autobaud feature. The default setting for the baud rate is 115200.

**Figure 39** Baud rate configuration menu

```
Baud Rate Configuration Menu
X.XX.XX  XXXXXX  XXXXXXXXXXXXXXXXXXXX
          07/7/2005  08:56:22

1)  9600           2)  19200
3)  38400          4)  57600
5)  * 115200

X) Return to previous menu
```

---

 **NOTE:** The asterisk (\*) symbol indicates the current setting for the baud rate.

---

## Ethernet configuration

This option allows for setting up all Ethernet network settings including IP address, subnet mask, IP gateway, security settings, Ethernet mode, physical address, and host name.

**Figure 40** Ethernet configuration menu

```

                                Ethernet Configuration Menu
                                X.XX.XX  XXXXXX  XXXXXXXXXXXXXXXXXX
                                07/7/2005  08:56:22

IP Address                      : 192.168.60.203 [DHCP]
Subnet Mask                     : 255.255.255.0
IP Gateway                      : 192.168.60.1
Ethernet Physical Address       : 00:E0:02:E3:17:51
Ethernet Mode                   : 10/100Mbps (Auto-Neg)
Host name                       : network storage router
DHCP Configuration             : Enabled

1) Change IP Address
2) Change IP Subnet Mask
3) Change IP Gateway
4) Change Ethernet Physical Address
5) Toggle Ethernet Mode
6) Change Hostname
7) Toggle DHCP Configuration
8) Change Security Settings

X) Return to previous menu
```

- Select **1** to change the IP address of the network storage router.
- Select **2** to change the IP subnet mask for the network storage router.
- Select **3** to change the IP gateway for the Ethernet network of the network storage router.
- Select **4** to change the Ethernet physical address, or MAC address, of the network storage router. Since Ethernet physical addresses are always assigned to Ethernet adapters by the manufacturers, HP recommends that this setting not be changed.
- Select **5** to toggle the Ethernet mode among the following options:
  - 10Mps Only
  - 100Mps (half duplex) Only
  - 100Mps (full duplex) Only
  - 10/100Mps (Auto-Neg.) **Default**
- Select **6** to change the host name. This is an alphanumeric entry of one word up to eight characters long.

---

 **NOTE:** Do not use a capital Z as a part of the host name because this is the autobaud hot key used by the MS Windows terminal utility for serial connections.

---

- Select **7** to toggle the DHCP setting. This setting enables/disables support for Dynamic Configuration Protocol. The default setting is enabled. When enabled, the network storage router retrieves a dynamic IP address from a DHCP server located on the Ethernet network that the network storage router is connected to.

If DHCP is disabled and then enabled, it is necessary to **save** the current configuration and **reboot** the network storage router before an IP address can be requested from the DHCP server. Use the following four steps:

- a. Select **X Return to previous menu**.
- b. Select **A Save Configuration**.
- c. Select **X Return to previous menu**.
- d. Select **4 Reboot**.

After the network storage router finishes rebooting, the Main menu appears on the serial interface. For Telnet, a new session needs to be opened to continue configuring the network storage router. DHCP status can be verified from the Ethernet Configuration menu where DHCP Configuration is indicated as Enabled, if DHCP has been successfully activated. Note that the IP address may also appear different than the former non-DHCP IP address.

---

 **NOTE:** To use the DHCP feature, a DHCP server must be operational on the Ethernet network used by the network storage router. If the DHCP feature is used when there is no DHCP server, the standard for DHCP requires that the network storage router wait three minutes for a response from a DHCP server before timing out.

---

Your DHCP server may allow you to set up a extended lease reservation for an IP address by providing the server with the Ethernet MAC address of the network storage router. This sets the DHCP server to always provide the same IP address to the network storage router. This setup can be useful for remote management of the network storage router via Telnet or Visual Manager. Because the method of setting up a lease reservation varies depending on the DHCP server being used, HP recommends that you contact your Network Administrator for assistance.

- Select **8** to change security settings, including the user name and password. User names and passwords should be unique and kept confidential and HP recommends using a combination of letters and numbers when creating user names and passwords.

## Fibre Channel configuration

This menu allows for setting the Fibre Channel Address method, Hard Address value, discovery mode, WWN overrides, tape backup settings, default map value, and FC port mode.

**Figure 41** Fibre Channel configuration menu

```
Fibre Channel Configuration Menu
X.XX.XX XXXXXX XXXXXXXXXXXXXXXXX
07/7/2005 08:56:22

Current Fibre Channel Configuration - Port 0:

FC Link Status      : DOWN
Node Name           : 0x100000E0 02031751
Port Name           : 0x100000E0 02231751
Port Mode           : N_Port Mode
Discovery Mode      : Manual Discovery Only
Buffered Tape Writes : Enabled, Queue Depth = 5
Current Default Map : 'Indexed'
Port Speed          : 2 GigaBit

1) Change World Wide Name High      2) Change World Wide Name Low
3) Toggle Port Mode                 4) Change ALPA Value
5) Toggle Discovery Mode             6) Toggle Buffered Tape Writes
7) Change Buffered Tape Queue Depth 8) Change Default Map Value
9) Edit FC Override Settings
A) Toggle Port Speed
X) Return to previous menu

Command >
```

 **NOTE:** For In-Band Management to be operational, WWN naming schemes **must** be compliant with IEEE Fibre Channel Format 1, where the left-most hexadecimal character (the NAA field) of the WWN is **1**. Further, the upper nibble of the third byte (the sixth hexadecimal value from the right) must be a value of **0** or **1**.

- Select **1** to enter a new value for the World Wide Name High. Ordinarily, this value should not be changed.

 **NOTE:** Resetting factory defaults overwrites any value a user has previously manually entered for the WWN.

- Select **2** to enter a new value for the World Wide Name Low. Ordinarily, this value should not be changed.

 **NOTE:** Resetting factory defaults overwrites any value a user has previously manually entered for the WWN.



- Select **3** to change the Toggle Port Mode between Auto Sense - Soft AL\_PA, N\_Port, and Auto Sense - Hard AL\_PA. The default setting is N\_Port mode. In this mode, the FC port tries coming up as a fabric port. If the network storage router is on a loop and N\_Port mode is selected, an error in communication may occur. In Autosense - Soft AL\_PA mode, the network storage router FC port tries to come up as a loop, and if not successful, then tries to come up as a fabric. If the port comes up as a loop, it determines whether it's on a private or public loop. If Auto Sense - Hard AL\_PA is selected, a unique one-byte valid value (derived from an Arbitrated Loop Topology as defined in ANSI specification FC\_AL 4.5) is used for the Fibre Channel configuration. When configuring the Fibre Channel AL\_PA, the network storage router presents a list of loop addresses along with the corresponding AL\_PA. From here, the user can select the loop address desired.
- Select **4** to set the Hard AL\_PA Value by entering a node number from the AL\_PA lookup table that appears when this option is selected. For more information, see "[Arbitrated Loop Node number to AL\\_PA lookup table](#)" on page 114 in "[Addressing, structures, and operations](#)" on page 113.
- Select **5** to toggle the Discovery Mode among the following options:
  - Auto Discovery on Reboot Events
  - Auto Discovery on Link Up Events
  - Manual Discovery Only

---

 **IMPORTANT:** HP recommends that you only use the **Manual Discovery Only** setting.

---

Discovery Mode determines how the network storage router discovers a new FC devices.

**Auto Discovery** allows the network storage router to automatically discover all Fibre Channel devices when the network storage router reboots.

- **Reboot Events** discovers both the ports and the devices behind the ports.
- **Link-up Events** discovers both the ports and the devices behind the ports for the first link-up event (which is the first reboot of the network storage router). Subsequent link-up events only discover the ports and not the devices behind the ports.

**Manual Discovery** is the default selection and sets discovery of new devices to only occur after the user selects the Refresh Device Display option from the Display Attached Fibre Channel Devices menu, located under **Main menu > System Utilities > System Statistics > Display Fibre Channel Protocol Status > Display Attached Fibre Channel Devices > Refresh Device Display**.

- Select **6** to toggle Buffered Tape Writes to enabled or disabled. Buffered Tape Writes is an option designed to enhance system performance. By returning status on consecutive write commands prior to the tape device receiving data, Buffered Tape Writes remove the latency of waiting for responses from the tape device. In the event that data does not transfer correctly for any reason, the network storage router returns a check condition on a subsequent command.

---

 **NOTE:** The default setting is enabled. If the application requires confirmation of individual blocks being written to the medium, such as audit trail tapes or log tapes, this option should be disabled.

---

- Select **7** to change the Tape Backup Queue Depth. Select a value from 0 through 10.
- Select **8** to change the Default Map Value for the current port. This can be Indexed, Auto-assigned, or SCC. The default setting is Indexed. The FC Auto-assigned map contains all the SCSI devices that are attached to the network storage router.

---

 **NOTE:** When a new initiator contacts the network storage router through the selected port, it accesses the devices that are in this map by default.

---

- Select **9** to edit the FC override settings.

Following are descriptions for each of the override settings:

---

 **NOTE:** Normally, override settings should not be changed except when directed to do so by an authorized HP technician.

---

- Select **1** to toggle the **Hi-Sup Bit** between SET and CLEAR. The default setting is CLEAR. This option should be toggled to SET when the server uses the Hi-Sup bit to scan for FC LUNs greater than eight.

---

 **NOTE:** Hi-Sup Bit is only set in an Active Fabric LUN which needs to be mapped as the first device (FC LUN 00).

---

- Select **2** to toggle the **Force FCP Response Code** between OFF and ON for support of Compaq-specific HBAs #223180-B21 and #120186-001. The default setting is OFF.
- Select **3** to toggle the **Initiator/Target Bit Setting in PRLI** between INITIATOR Bit Set, TARGET Bit Set, INITIATOR & TARGET Bits Set, and INITIATOR & TARGET Bits CLEAR. This should be configured to one of the options for SET on both network storage routers/routers when using the network storage router in a network storage router-to-router configuration (a configuration where at least one network storage router/router appears as a target to at least one other network storage router/router that appears as an initiator). The default setting is INITIATOR & TARGET Bits SET.
- Select **4** to toggle the **Initiator/Target Bit Setting in PRLI\_ACC** between INITIATOR Bit Set, TARGET Bit Set, INITIATOR & TARGET Bits Set, and INITIATOR & TARGET Bits CLEAR. This should be configured to one of the options for SET on both network storage router/routers when using the network storage router in a network storage router-to-router configuration (a configuration where at least one network storage router/router appears as a target to at least one other network storage router/router that appears as an initiator). The default setting is TARGET BIT SET.
- Select **5** to toggle **FC Confirm Setting in PRLI\_ACC** between FC CONFIRM SET and FC CONFIRM CLEAR. The default setting is FC CONFIRM SET. This option should be toggled to FC CONFIRM SET when the server is using QLogic HBAs.
- Select **6** to access the **Target Reset Mode** menu. The default setting is setting **ALTERNATE**.

Following are descriptions for each of the settings:

- Select **1** to use a normal SCSI bus reset code to recover from a bus problem.
- Select **2** to use a progressive SCSI bus recovery mechanism that first attempts to recover the bus by attempting a target reset and, if this fails, then trying the bus reset.
- Select **7** to toggle **Force FLOGI in Private Loop** between Disabled and Enabled. The default setting is Disabled. FLOGI Fabric Login is a process by which a node makes a logical connection to a fabric switch. This setting should be used to connect the attached Fibre Channel devices as private loop devices for certain switched fabric environments.
- Select **A** from the Fibre Channel Configuration menu to toggle the port speed between 1, 2, and 4 Gb/s for the selected FC port.

## Parallel SCSI configuration

This menu allows for setting up SCSI attributes.

**Figure 42** Parallel SCSI configuration menu

```
Parallel SCSI Configuration Menu
X.XX.XX  XXXXXX  XXXXXXXXXXXXXXXXXXXX
          07/7/2005  08:56:22

Current SCSI Configuration - Bus 0

Discovery                : Enabled
Bus Reset on Boot        : Enabled
Discovery delay time     : 30 seconds
Internal Termination     : Enabled

1) Edit Initiator Settings
2) Enable/Disable SCSI Discovery
3) Enable/Disable SCSI Reset on Boot
4) Set Discovery Delay Time
5) Set SCSI Termination Mode
6) Set Maximum SCSI Bus Connect Speed

X) Return to previous menu

Command, <enter> for next bus >
```

Press the **Enter** key to toggle the current menu to the next SCSI bus.

- Select **1** to edit the SCSI Initiator menu settings, described later in the chapter.
- Select **2** to enable/disable SCSI Discovery.
- Select **3** to enable/disable SCSI bus Reset on Boot. When enabled, the network storage router automatically resets SCSI buses after initial library power-up and after reboots.
- Select **4** to set the discovery delay time for SCSI devices. The default is 30 seconds. This is the time the network storage router waits after a power-up or reboot before starting to discover SCSI devices. This value should be set to no less than 250ms, according to the SCSI standard for Reset-to-Selection Time. This value may need to be increased to ensure that all SCSI devices complete their individual power-ups. With Discovery enabled, the Discovery Delay lengthens the time taken by the network storage router to reboot.
- Select **5** to toggle the SCSI termination mode between **Enabled** and **Disabled**. This option is automatically set to Enabled for Internal termination. The Internal setting allows the network storage router to internally terminate a SCSI connection. Setting this option to Disabled allows the SCSI bus, not the network storage router, to handle SCSI terminations.
- Select **6** to access menu settings for the maximum SCSI bus connection speed, described later in this chapter. Note that when this option is selected, the user is prompted to select a Target ID on the currently selected bus. Currently, maximum speed settings are shown.

## SCSI initiator menu

This option allows for setting up the SCSI Initiator.

**Figure 43** SCSI initiator menu

```
SCSI Initiator Menu
X.XX.XX XXXXXX XXXXXXXXXXXXXXXXXXXX
07/7/2005 08:56:22

Current Initiator Configuration - Bus 0

Initiator ID      : 07

1) Select primary SCSI Initiator ID
2) Enable/Disable alternate SCSI ID
   (The "alternate" ID is used to enhance the performance
   of status ("agent") commands that are being issued to a
   serial device. To use this feature enable the alternate
   ID and pick an ID that is currently unused on this bus.)
3) Select alternate SCSI Initiator ID

X) Return to previous menu
```

- Select **1** to select the primary SCSI Initiator ID. This is the ID for the SCSI device that requests operations from other SCSI devices known as targets. This should be a unique ID on the bus. This value is initially blank and the user must enter an integer value in the range of 0-15 prior to saving the configuration to the network storage router.
- Select **2** to enable/disable an alternate SCSI Initiator ID.
- Select **3** to select an alternate SCSI Initiator ID. This should be a unique ID on the bus. The default value is 6. This option is used to enhance the performance of status (agent) commands issued to a serial device.

## Maximum SCSI bus speed menu

This option allows for setting the maximum SCSI bus speed. When this option is selected, the user must first select the Target ID for the bus before this menu appears.

**Figure 44** SCSI bus speed configuration menu

```
SCSI Bus Speed Configuration Menu
X.XX.XX  XXXXXX  XXXXXXXXXXXXXXXXXXXX
07/7/2005  08:56:22

Bus 0, Target 15 Current Configuration:

Maximum SCSI Bus speed set to Ultra320 (320 MB)

1) Set Maximum Speed to Ultra320: (320 MB)
2) Set Maximum Speed to Fast-160 (160 MB)
3) Set Maximum Speed to Ultra 2 (80 MB)
X) Return to previous menu
```

- Select **1** to set the maximum SCSI bus speed to Ultra320. This setting provides support for transfer rates of up to 320 Megabytes per second. This is the default setting.
- Select **2** to set the maximum SCSI bus speed to Fast-160. This setting provides support for transfer rates of up to 160 Megabytes per second.
- Select **3** to set the maximum SCSI bus speed to Ultra 2. This setting provides support for transfer rates of up to 80 Megabytes per second.
- Select **X** to return to the Target ID selection prompt where a different Target ID can be selected.

## Device mapping

This option allows the user to manipulate maps and associate a selected host with a particular map. Each physical port/bus on the system has at least an *Indexed* map and an *Auto Assigned* map. In addition, there is a *SCC Map* and a *Port 0 Device Map* on FCP ports. Each map has a unique name and map ID. You can rename all maps, except for **Indexed**, **Auto Assigned**, and **SCC**. The map that is set to be current must always contain valid information, since many of the operations on the map menu are executed against this map.

**Figure 45** Device mapping main menu

```
Device Mapping Main Menu
X.XX.XX  XXXXXX  XXXXXXXXXXXXXXXXXXXX
07/7/2005  08:56:22

Current Default Map for FCP Port 0 - 'Indexed'

1) Select Current Map
2) Display Current Map
3) Create New Map
4) Remove Current Map
5) Edit Current Map
6) Clone Current Map
7) Edit Host List for Current Map
8) Display Device List
9) Activate Mapping and Save

X) Return to previous menu

Command >
```

- Select **1** from the **Device Mapping Main menu** to display all the maps defined by the system for the current protocol/port, and to choose one of the maps from the list to make it a **current** map. The map selected from this list is the one used by the network storage router to direct data to the appropriate targets and initiators.

---

 **NOTE:** Because the entire list of maps may not fit on one screen, select **N** or **P** to go back and forth between screens displaying more maps. Select **X** to return to the Device Mapping Main menu.

---

Enter the number from the column on the left side of the table to select a map and make it **Current**. For example, entering **3** from the picture above would select the map named **SCC Map** on Fibre Channel Port 0 and make it a **Current** map.

- Select **2** from the Device Mapping Main menu to display the content of the **current** map. This option displays all the entries in the map. Information in the local part of the address (left) depends on the type of protocol for which the map is defined. The specific device address information depends on the protocol/port where the device resides. Mapping a device to the same port where it resides is not allowed. (that is, you can not map a disk on FCP Port 0 to an address on FCP Port 0.)

---

 **NOTE:** Because the entire list of maps may not fit on one screen, select **N** or **P** to go back and forth between screens displaying more maps. Select **X** to return to the Device Mapping Main menu.

---

- Select **3** from the Device Mapping Main menu to create a new map. This option allows adding a new map for the current protocol/port or bus. Once the map is created, it becomes the current map.
  - Select **4** from the Device Mapping Main Menu to delete current map. The screen asks for confirmation before deleting the map. After the map has been deleted, the default map for the current port becomes the current map. Maps with names Indexed, Auto Assigned or SCC Map may not be removed.
  - Select **5** from the Device Mapping Main menu to edit current map. This option displays the **Map Edit menu** and allows user to edit the name of the map, change content of the map, clear, and fill the map. Editing an Auto Assigned or SCC Map is not allowed.
- 

 **NOTE:** Enter the number of one of the available selections, or enter **X** to exit to the Device Mapping Main menu.

---

- Select **1** from the **Map Edit** menu to edit the name of the current map. The name of the Indexed map may not be changed. Map name also cannot be left empty.
  - Select **2** from the **Map Edit** menu to edit entries in the current map. This screen allows the user to navigate up and down the map entries and create or remove entries. Device lists are also available to the user to make it easier to identify the device to be mapped. Mapping device to its native port/bus is not allowed. The information needed to create entries is protocol/port dependent.
- 

 **NOTE:** Control of the editing process is done with simple single letter commands. Select **N** and **P** to scroll up and down the map entries. Select **X** to return to the Map Edit menu. Select **A** to add a new entry to the map or **D** to delete an already existing entry in the map. Select **R** to remove the gaps in the map.

---

 **NOTE:** SCSI devices attached to a Fibre Channel port must be mapped as sequential FC LUNs starting at LUN number 00. Skipping LUN numbers is not recommended when mapping FC LUNs because FC Discovery stops the discovery process whenever an empty LUN position is found.

---

## Adding an entry

To add a new entry, the user must enter the desired Index. If the selected Index is already present in the map, the user is asked to confirm the override or enter different address information. Next, the operator is prompted for the protocol and port at which a device selection list is generated. (Devices may not be mapped to their native port).

The following is an example of adding an entry for an FCP map:

**Figure 46** Adding an FCP port entry

```
Enter desired Index > 0

Select Protocol (0 - SCSI, 1 - AF, X=Cancel) > 0
Select SCSI Port: Port# = ? (0-1,X=Cancel) > 1
```

---

 **NOTE:** If the operator selects a device with LUN '-', all LUNs for this Target are added to the map.

---

---

 **NOTE:** Hi-Sup Bit is only set in an Active Fabric LUN which needs to be mapped as the first device (FC LUN 00).

---

Select a number from the left column **Num** to add a device to the map. Selecting a device where LUN='.' adds all LUNS for this target. If the selected device is already mapped, an error message appears to warn the user about adding a duplicate device. **N** and **P** controls allow scrolling up and down the device list. **X** brings the user back to the **Edit Map Entries** display table.

## Creating an entry

The user can create an empty map, or use an existing map to pre-enter devices that are not yet online. To perform this operation, the user has to know all the essential information about the device. A series of questions are asked to guide the user through the process. The questions vary based on the **current** map protocol.

The user is asked to:

- Select the LUN address for a device,
- The protocol/port on which device it resides,
- The Name for the device (which can be left empty),
- And the type of device

**Figure 47** Creating an entry for FCP port map

```
Enter desired lun address > 1

Select Protocol (0 - SCSI, X=Cancel) > 0
Enter desired Device Name (could be empty) >

DISK_DEVICE          - 0,  TAPE_DEVICE          - 1
PRINTER_DEVICE       - 2,  PROCESSOR_DEVICE - 3
WORM_DEVICE          - 4,  CDROM_DEVICE       - 5
SCANNER_DEVICE       - 6,  OPTICAL_DEVICE      - 7
MEDIUM_CHGR_DEVICE  - 8,  COMM_DEVICE         - 9
ARRAY_CTLR_DEVICE    - 12, ENCLOSURE_SRV_DEVICE - 13

Enter desired Device Type > 1

Enter device target id > 5

Enter device lun id > 0
```

---

 **NOTE:** If the device being added is a SCSI device, the user is also asked to enter Target ID and LUN ID for the device. Target ID must already be defined in the SCSI Configuration. Otherwise, adding a device is not permitted.

---

 **NOTE:** Select MEDIUM\_CHGR\_DEVICE for the library or robot controller.

---

 **NOTE:** When creating a device that does not exist, it will be displayed with **Down** status.

---



## Remove gaps

 **NOTE:** SCSI devices attached to a Fibre Channel port must be mapped as sequential FC LUNs starting at LUN number 00. Skipping LUN numbers is not recommended when mapping FC LUNs because FC Discovery stops the discovery process whenever an empty LUN position is found.

This option removes any incremental gaps in the sequence of LUNs listed in the table.

## Deleting an entry

The user selects a LUN ID.

**Figure 48** Deleting an entry

```
Select LUN to delete (X=Cancel, D=DeleteMultiple) > 0

Are you sure you want to delete LUN 0? (Y=Confirm, X=Cancel) > y
```

Select **D** to delete multiple LUNs:

 **NOTE:** When deleting multiple LUNs, the user can list the LUNs to delete in a comma or space delimited format.

- Select **3** from the Map Edit menu to clear (that is, remove all entries from) the current map. The user is prompted for confirmation.
- Select **4** from the Map Edit menu to fill the current map. This selection scans the device list and appends all unmapped devices at the end of the current map. Devices marked as **DOWN** are not mapped. After this operation completes, the Edit Map Entries screen appears.
- Select **6** from the Device Mapping Main menu to clone current map. This option allows the user to make an exact copy of an already existing map complete with all entries. Cloning of **Auto Assigned** or **SCC Map** is not allowed. The new map must have a unique map ID and name. Once cloning is complete, the newly created map becomes current map. The purpose of this option is to create a base for a new map that is similar to an already existing map.
- Select **7** from the Device Mapping Main menu to edit the host list for the current map. The current map can be associated with hosts available in the host list on the same port where the map is defined. Initially all hosts are associated with an Indexed map. These are **built at runtime** hosts. They cannot be edited or deleted; their name cannot be changed.

The following is an example of a host list for FCP hosts:

**Figure 49** Host list for FCP hosts

```
Host List Edit Display
X.XX.XX XXXXXX XXXXXXXXXXXXXXXXXXXX
07/7/2005 08:56:22

Current Map: FCP Port 0 - Name 'Indexed'

FCP Port# 0 Host List:
+-----+-----+-----+-----+-----+
| Num | Port WWN | Node WWN | Host Name | | Active Map Name |
+-----+-----+-----+-----+-----+
| 1 | Hi 0x210000E0 | Hi 0x200000E0 | (built at runtime) | | Indexed |
| | Lo 0x8B02C20E | Lo 0x8B02C20E | PortID = 0x0000EF | | |
+-----+-----+-----+-----+-----+

Page # 1 out of 1 pages.
Total Number of Hosts = 1
Select Host Number(1 - 1) to associate host with the Current Map
Enter (N=Next, P=Prev, A=Add, D=Delete, E=Edit, X=Exit) >
```

 **NOTE:** Because the entire list of hosts may not fit on one screen, select **N** or **P** to see any additional pages showing the list of hosts. Select **X** to return to the Device Mapping Main menu. Select a number from the column on the left to associate a host with the **current** map. At this point the user can edit, delete, or change the name for the host.

## Adding a host

Select **A** to add a host to the list. The user is prompted to enter the desired Host Name, Host ID, Port WWN and Node WWN for FCP host. WWN values are hexadecimal. If the user doesn't know the Host ID, the host won't be added to the host list. Duplicate hosts won't be added to the list.

**Figure 50** Adding a FCP host

```
Enter desired Host Name > FCP Host
Do you know Port ID of the Host?(y/n) > y

Enter Host ID of the host > 0000ef

Enter the new host's Port WWN High > 210000E0

Enter the new host's Port WWN Low > 8B02C20E

Enter the new host's Node WWN High > 200000E0

Enter the new host's Node WWN Low > 8B02C20E
Host was successfully added to the host list!!!
```

Following the successful addition of the host, the host list is displayed again and the user can make sure that the host information is correct.

## Deleting a host

Select **D** to delete a host from the host list. The operator is asked to enter an index for the host that is displayed in the very left column of the table, and asked for confirmation.

## Editing a host

Select **E** to edit host information. Old information is displayed on the screen, and the user is asked to enter information to replace it, or just hit **Enter** to keep old information. All of the information entered by the user is validated. The following is an example of editing a host list for an FCP Port:

**Figure 51** Editing host list for FCP port

```
Host List Edit Display
X.XX.XX XXXXXX XXXXXXXXXXXXXXXXXXXX
07/7/2005 08:56:22

Current Map: FCP Port 0 - Name 'Indexed'
FCP Port# 0 Host List:
+-----+-----+-----+-----+-----+
| Num | Port WWN | Node WWN | Host Name | Active Map Name |
+-----+-----+-----+-----+-----+
| 1 | Hi 0x210000E0 | Hi 0x200000E0 | | Default |
| | Lo 0x8B02C20E | Lo 0x8B02C20E | PortID = 0x0000EF | |
+-----+-----+-----+-----+-----+

Page # 1 out of 1 pages.
Total Number of Hosts = 1
Select Host Number(1 - 1) to associate host with the Current Map
Enter (N=Next, P=Prev, A=Add, D=Delete, E=Edit, X=Exit) > e

Select Host to edit (X=Cancel) > 1
Old Host Name:
Enter desired new name (<enter> = use old name) > New FCP Host

Old host's Port WWN High: 0x210000E0
Enter desired Port WWN High(<enter> = use old Port WWN High) >

Old host's Port WWN Low: 0x8B02C20E
Enter desired Port WWN Low(<enter> = use old Port WWN Low) >

Old host's Node WWN High: 0x200000E0
Enter desired Node WWN High(<enter> = use old Node WWN High) >

Old host's Node WWN Low: 0x8B02C20E
Enter desired Node WWN Low(<enter> = use old Node WWN Low) >
```

- Select **8** from the Device Mapping Main menu to display the entire device list. Because the entire device list may not fit on one screen, select **N** or **P** to go back and forth between screens displaying more maps. Select **X** to return to the Device Mapping Main menu.

**Figure 52** Entire device list

```

Entire Device List
X.XX.XX XXXXXX XXXXXXXXXXXXXXXXXXXX
07/7/2005 08:56:22

+-----+-----+-----+-----+-----+-----+-----+-----+-----+
+
| # | | Prtl | Port | TYPE | STAT | Protocol Specific Information | Rt | Ct |
+-----+-----+-----+-----+-----+-----+-----+-----+-----+
+
| 1 | | SCSI | 1 | TAPE | UP | Target= 3 Lun= 0 | 2 | 2 |
| 2 | | SCSI | 2 | TAPE | DOWN | Target= 5 Lun= 0 | 1 | 1 |
| 3 | | SCSI | 5 | TAPE | UP | Target= 1 Lun= 0 | 2 | 2 |
+-----+-----+-----+-----+-----+-----+-----+-----+-----+
+
Page # 1 out of 1 pages.

===> Number of entries in the Device Table = 3

Enter (N=Next, P=Prev, X=Exit) >

```

- Select **9** from the Device Mapping menu to activate port mapping changes.

**CAUTION:** Before activating any port mapping changes, HP strongly recommends that the user verifies there are not any command or data operations occurring in conjunction with devices affected by the mapping changes. For example, deleting a LUN or device from a map may disrupt I/O transfers with that device. It is the user's responsibility to ensure that no operations are negatively impacted due to the activation of mapping changes.

**NOTE:** All current mapping settings take effect immediately. If another management interface has made unsaved mapping changes, those changes are lost. Current mapping settings are also not visible in other interfaces until the network storage router is rebooted.

**NOTE:** If the Activate Port Mapping Changes option is not selected, the mapping changes do not take effect until the network storage router is rebooted.

## Trace and event settings configuration

This option allows set up of trace and events settings.

**Figure 53** Utility settings

```
Utility Settings
X.XX.XX XXXXXX XXXXXXXXXXXXXXXXXXXX
07/7/2005 08:56:22

1) Trace Settings Configuration
2) Event Settings Configuration
3) Special Event Logging Configuration

X) Return to previous menu
```

- Select **1** to edit the trace settings configuration.
- Select **2** to edit the event settings configuration.
- Select **3** to edit the special event logging configuration.

## Trace configuration

This option allows trace levels to be set. These settings should not be modified in normal operation, as performance degradation may result. There are two pages of trace levels.

**Figure 54** Trace settings

```
Trace Settings
X.XX.XX XXXXXX XXXXXXXXXXXXXXXXXXXX
07/7/2005 08:56:22

0) General Errors      : ON
1) FCP Driver          : OFF
2) FCP Transport      : OFF
3) FCP Management     : OFF
4) PS Transport       : OFF
5) PS Management      : OFF
6) PS Driver          : OFF

U) Update Current Operating Trace Levels
X) Return to previous menu

Enter the trace level index, <enter> for next page >
```

If the Enter key is selected, the next page of trace levels appears as follows:

**Figure 55** Trace settings

```
Trace Settings
X.XX.XX XXXXXX XXXXXXXXXXXXXXXXXXXX
07/7/2005 08:56:22

0) SG List           : OFF
1) Timing            : OFF
2) FCP/RMI           : OFF
3) AF                : OFF
4) INBAND            : OFF
5) Multi-Host Lib    : OFF
6) Queue Element     : OFF

U) Update Current Operating Trace Levels
X) Return to previous menu

Enter the trace level index, <enter> for next page >
```

Enter a level number from the Trace Settings that are shown. This toggles the current setting to either **ON** or **OFF**.

Select **U** to update current operating trace levels. This option forces the currently displayed trace settings to become effective immediately, without requiring a reboot or power cycle.

---

 **NOTE:** Be sure to set the clock and date in the Real-Time Clock Configuration menu so event logging is accurate.

---

## Event configuration

This option allows selecting the event threshold for filtering event logging. The asterisk denotes the current setting.

**Figure 56** Event filter settings

```
Event Filter Settings
X.XX.XX XXXXXX XXXXXXXXXXXXXXXXXXXX
07/7/2005 08:56:22

1) Disable Event Logging 6) Warning events
2) Emergency events      7) Notify events
3) Alert events          8) Info events
4) Critical events       9) Debug events
5) Error events          0)* Log all events

U) Update Current Operating Trace Levels
X) Return to Previous menu

Enter event threshold <0-9> >
```

- Enter **1** to disable event logging.
- Enter **2** through **9** to log the specified events or higher.
- Enter **0** to log all events.
- Select **U** to send event configuration changes to the network storage router now.

---

 **NOTE:** Event logging captures over 2000 events and then starts overwriting the log when full.

---

 **NOTE:** Be sure to correctly set the clock and date in the Real-Time Clock Configuration menu so that event logging is accurate.

---

## Special event logging configuration

This option allows selecting the special event log settings.

**Figure 57** Special event log settings

```

Special Event Log Settings
X.XX.XX  XXXXXX  XXXXXXXXXXXXXXXXXXXX
07/7/2005  08:56:45

Abort Event Logging           : Disabled
Reservation/Release Events Logging : Disabled
Prevent Media Removal Events Logging : Disabled

1) Toggle Abort Event Logging
2) Toggle Reservation/Release Event Logging
3) Toggle Prevent Media Removal Event Logging

U) Update Current Operating Special Event Logging
X) Return to Previous menu

```

- Enter **1** to toggle Abort Event Logging.
- Enter **2** to toggle Reservation/Release Event Logging.
- Enter **3** to toggle Prevent Media Removal Event Logging.
- Select **U** to send event configuration changes to the network storage router now.

## Real-Time clock configuration

When this option is selected from the Perform Configuration menu, the System Clock Setup menu appears.

**NOTE:** The time is based on a 24-hour clock. There is no a.m. or p.m. designation. For example: 1:00 p.m. is 13 hours 00 minutes or 13:00.

**Figure 58** System clock setup menu

```
System Clock Setup Menu
X.XX.XX  XXXXXX  XXXXXXXXXXXXXXXXXXXX
          07/7/2005  08:56:22

TUESDAY, Date: 07/7/2005, Time: 08:56:22

1) Set clock
X) Return to previous menu
```

Select **1** to set the clock. A series of three prompts appear allowing the set up of 24 hour time (hh:mm:ss), current date (mm/dd/yyyy), and the day of week (SUN, MON, TUE, WED, THU, FRI, SAT). For time, it is not necessary to enter the seconds, that is, hh:mm is an acceptable format. For the date, the month and day can be entered as single digits, for instance **6** instead of **06**.

## Active fabric configuration

When this option is selected from the Perform Configuration menu from the Main menu, the Active Fabric menu appears.

**NOTE:** An Active Fabric Controller LUN is needed when using Library & Tape Tools to upgrade the network storage router firmware, and to generate support tickets.

**Figure 59** Active fabric configuration menu

```
Active Fabric Configuration Menu
X.XX.XX  XXXXXX  XXXXXXXXXXXXXXXXXXXX
          07/7/2005  08:56:22

Current Active Fabric Configuration:

Server Free Backup Mode           : DISABLED
Number of network storage router LUNS (0-4)      : 1
network storage router LUNS in auto-assigned map go: last

1) Change number of network storage router LUNS
2) Change location of luns in auto-assigned map

X) Return to previous menu
```

- Select **1** to change the number of network storage router LUNs reported by the network storage router. This value can be set to a number in the range of 0 to 4.



- Select **2** to change the location of LUNs in an auto-assigned map. LUNs can be positioned starting at the beginning (first location) or at the end (last location) of the map.

---

 **NOTE:** Controller LUNS in auto-assigned map settings are First or Last. Setting the choice to Last is recommended. Setting the choice to First can cause issues with HP-UX. However, if working with an OVMS host, it should be set to First.

---

For more information on network storage router LUNs, see “[Inband SCSI-3 commands](#)” on page 109.

## Save configuration

This option saves the current configuration state in FLASH, which updates the saved previous configuration state. Saved changes are retained across future device resets or power cycles.

## Restore last saved configuration

This option restores the most recently saved configuration. This can be useful when configuration changes are made, but the user wishes to return to the previously saved configured state. The changes take effect after the network storage router has rebooted.

## Reset to factory defaults

This option resets all current configuration options to the factory defaults and saves those options to FLASH memory as the current configuration. The changes take effect after the network storage router has rebooted.

## System utilities

**Figure 60** System utility menu

```
System Utility Menu
X.XX.XX  XXXXXX  XXXXXXXXXXXXXXXXXXXX
07/7/2005  08:56:22

1) System Statistics Menu
2) Event Log
3) Runtime Report
4) Enter System Diagnostics Mode
5) Special Fibre Channel Link States
6) SCSI Command Tracking

X) Return to main menu
```

- Select **1** to display the System Statistics menu, described later in this chapter.
- Select **2** to display the Event Log menu, described later in this chapter.
- Select **3** to view the Runtime Report, described later in this chapter.
- Select **4** to enter diagnostics mode. A confirmation message appears verifying that you want to do this. If you enter **N** for No, you are returned to the System Utilities menu. If you enter **Y** for Yes, the network storage router enters System Diagnostics Mode. This option is described in more detail later in this chapter.
- Select **5** to access a special diagnostic utility. This utility should not be used unless under the guidance of an authorized HP technician.
- Select **6** to display the SCSI Command Tracking menu, described later in this chapter.

## System statistics menu

**Figure 61** System status/statistics menu

```
System Status/Statistics menu
X.XX.XX XXXXXX XXXXXXXXXXXXXXXXXXXX
07/7/2005 08:56:22

1) Display System Status
2) Display Fibre Channel Protocol Status
3) Display Parallel SCSI Protocol Status

X) Return to main menu
```

- Select **1** from the System Status/Statistics menu to display system status.

**Figure 62** System status menu

```
System Status Menu
X.XX.XX XXXXXX XXXXXXXXXXXXXXXXXXXX
07/7/2005 08:56:22

1) Display memory statistics
2) Display active tasks
3) Display stack usage
4) Display SCSI Protocol Resources

X) Return to previous menu
```

- Select **1** to display memory statistics.
- Select **2** to display active tasks.
- Select **3** to display stack usage.
- Select **4** to display SCSI Protocol Resources.
- Select **2** from the System Status/Statistics menu to display Fibre Channel Protocol Status.

- Select **1** from the Fibre Channel Status menu to display Fibre Channel Link Status. [Figure 63](#) below shows the status and statistics for a Fibre Channel loop. Similar data can also be shown for a Fibre Channel fabric.

**Figure 63** Fibre Channel status menu

```

Fibre Channel Status & Statistics
X.XX.XX XXXXXX XXXXXXXXXXXXXXXXXXXX
07/7/2005 08:56:22

Current Fibre Channel Status - Port 0

LinkState      DOWN          ALPA          x00000000    InDevDataSeqs x00000000
OutDevDataSeq  x00000000    InLnkDataSeqs x00000000    OutLnkDataSeq  x00000000
InP_BSYFrames  x00000000    OutP_BSYFrms  x00000000    InF_BSYFrames  x00000000
InP_RJTFrames  x00000000    OutP_RJTFrame x00000000    LinkDowns      x00000000
InABTSs        x00000000    OutABTSs      x00000000    LaserFaults    x00000000
SignalLosses   x00000001    SyncLosses    x00000001    BadRxChars     x000000FF
LinkFailures   x00000001    BadCRCFrames  x00000000    ProtocolErrs   x00000000
BadSCSIFrames  x00000000    UnderflowErrs x00000000

A) Autorepeat
C) Clear Statistics
X) Return to previous menu

Command >

```

**Table 6** Fibre Channel status

<b>LinkState</b> is the current FC link status.
<b>AL_PA</b> is the arbitrated loop physical address.
<b>InDevDataSeqs</b> is the number of device data sequences received by this port.
<b>OutDevDataSeq</b> is the number of device data sequences transmitted by this port.
<b>InLnkDataSeqs</b> is the number of link data frames received by this port.
<b>OutLnkDataSeq</b> is the number of link data frames transmitted by this port.
<b>InP_BSYFrames</b> is the number of P_BSY frames received by this port.
<b>OutP_BSYFrms</b> is the number of P_BSY frames transmitted by this port.
<b>InF_BSYFrames</b> is the number of F_BSY frames received by this port.
<b>InP_RJTFrames</b> is the number of P_RJT frames received by this port.
<b>OutP_RJTFrame</b> is the number of P_RJT frames transmitted by this port.
<b>LinkDowns</b> is the number of link down conditions detected.
<b>InABTSs</b> is the number of ABTS frames received.
<b>OutABTSs</b> is the number of ABTS frames transmitted.
<b>LaserFaults</b> is the number of laser faults detected.
<b>SignalLosses</b> is the number of times loss of signal was detected.

**Table 6** Fibre Channel status

<b>SyncLosses</b> is the number of times loss of sync. was detected.
<b>BadRxChars</b> is the number of bad characters received.
<b>LinkFailures</b> is the number of link failure conditions.
<b>BadCRCFrames</b> is the number of frames received with a bad CRC.
<b>ProtocolErrs</b> is the number of protocol errors detected.
<b>BadSCSIFrames</b> is the number of bad SCSI frames detected.
<b>UnderflowErrs</b> is the number of underflow errors detected.

Select **A** to have the status information repeatedly refreshed.

- Select **2** from the Fibre Channel Status menu to display Attached Fibre Channel Devices.

**Figure 64** Fibre Channel device display

```
Fibre Channel Device Display
X.XX.XX  XXXXXX  XXXXXXXXXXXXXXXXXXXX
07/7/2005  08:56:22

FC Port: 0  Port id: 0x000001

R) Refresh Device Display
D) Display Device Details
X) Return to previous menu

Command, <enter> for next FC Port > r
Port 0: Requesting discovery
Doing device discovery on port 0...
Completed discovery on port 0

Fibre Channel Device Display
Version X.X XXXX

FC Port: 0  Port id: 0x000001

Port 0: TARGET DEVICE (UP)  Port id: 0x000010
HP Ultrium 3-SCSI  L22W  Type: Direct Access

R) Refresh Device Display
D) Display Device Details
X) Return to previous menu
```

Select **R** to refresh the device display (as shown in the menu above) with the latest status information and perform manual FC discovery (as set in the Fibre Channel Configuration menu described earlier in this chapter).

Select **D** to display device details.

- Select **3** to display FC Resource Status.
- Select **4** to display FC Driver Resource Status.

- Select **5** to display FC SeqCmd\_Q Resources.
- Select **6** to display FC SFP Data.
- Select **3** from the System Status/Statistics menu to display Parallel SCSI Protocol Status.

**Figure 65** Parallel SCSI protocol status menu

```

Parallel SCSI Protocol Status menu
X.XX.XX XXXXXX XXXXXXXXXXXXXXXXXXXX
07/7/2005 08:56:22

1) Display SCSI Statistics
2) Display Attached SCSI Devices
3) Display SCSI Resource Status

X) Return to previous menu

```

- Select **1** to display SCSI statistics.
- Select **2** to display attached SCSI devices.

**Figure 66** SCSI device display menu

```

SCSI Device Display Menu
X.XX.XX XXXXXX XXXXXXXXXXXXXXXXXXXX
07/7/2005 08:56:22

1) Issue discovery for all buses
2) Issue discovery for selected bus
3) Issue boot discovery (includes resets and delays)
4) Display all local devices
5) Display local devices on specified bus

X) Return to previous menu

```

- Select **1** to issue discovery for all SCSI buses.
- Select **2** to issue discovery for selected SCSI bus.
- Select **3** to issue boot discovery (includes resets and delays).
- Select **4** to display all local SCSI devices.
- Select **5** to display local devices on specified SCSI bus.
- Select **3** from the Parallel SCSI Protocol Status menu to display SCSI Resource Status.

## Event Log

When this option is selected from the System Utilities menu, the Event Log menu is displayed (see Figure 67).

**Figure 67** Event log menu

```
Event Log Menu
X.XX.XX  XXXXXX  XXXXXXXXXXXXXXXXXXXX
07/7/2005  08:56:22

1) Display event log
2) Clear event log

X) Return to previous menu
```

- Select **1** to display the event log.
- Select **2** to clear the event log of all old entries and start over with an empty list.

---

 **NOTE:** Event logging captures over 2000 events and then starts overwriting the log when full; therefore, the more types of events logged, the faster the log rolls over and overwrites events.

---

## Runtime report

When this option is selected from the System Utilities menu, the Runtime Report prompt is displayed (see Figure 68).

**Figure 68** Runtime Report

```
To save the Report to a file, enable your terminal's 'CAPTURE text' mode.

To start the Report, press 'y' (any other key cancels the Report): y

Runtime Report
X.XX.XX  XXXXXX  XXXXXXXXXXXXXXXXXXXX
07/7/2005  08:56:22

(... report details appear here ...)

*****  END of the Runtime Report  *****

The Report has been completed.  You may stop the file CAPTURE.

( Press any key to continue... )
```

The Runtime Report presents a consolidated listing of all system information, traces, and the event log.

## Diagnostics mode

When this option is selected from the System Utilities menu, a confirmation message appears to verify the selection. If a response of **Y** (yes) is given to the confirmation message, current network storage router activities are interrupted while the unit restarts itself and enters diagnostics mode. The power-up messages appear followed by the diagnostics menu (see [Figure 69](#)).

**Figure 69** System diagnostics mode

```
System Diagnostics Mode
X.XX.XX  XXXXXX  XXXXXXXXXXXXXXXXXXXX
07/7/2005  08:56:22

1) Perform Ethernet External Loopback Test
2) Perform Fibre Channel Loopback Test
X) Exit diagnostics mode and reboot
```

- Select **1** to perform a loopback test of the Ethernet connection on the network storage router unit. For the test to be performed correctly, an Ethernet loopback connector must be attached to the network storage router's Ethernet port before selecting this option.
- Select **2** to perform a loopback test of the Fibre Channel connection on the network storage router unit. For the test to be performed correctly, a Fibre Channel loopback connector must be attached to the network storage router's Fibre Channel port before selecting this option.

Selecting **X** (exit) from System Diagnostics Mode has a confirmation message to verify the selection. If **Y** (yes) is given to the confirmation message, the network storage router restarts itself and enters normal operation mode. The power-up messages appear followed by the main menu.

---

 **NOTE:** When exiting System Diagnostics Mode, remove any diagnostics cables before restarting the unit.

---

## Special Fibre Channel link control

When this option is selected from the System Utilities menu, the Special Fibre Channel Link Control menu is displayed (see [Figure 70](#)).

**Figure 70** Special FC Link states menu

```
Special FC Link Control
X.XX.XX XXXXXX XXXXXXXXXXXXXXXXXXXX
07/7/2005 15:05:45

Current FC Port 0:

Non Participating Mode = Off, LRC Bit in TL
Status Reg = Reset

1) Set FC Link to Non Participating Mode
2) Set FC LRC Mode Active ( bit=1 )
3) Set FC LRC Mode Inactive ( bit=0 )
4) Reset TL
5) Display TL Regs

X) Return to previous menu

Command, <enter> for next Port >
```

The settings provided on the Special FC Link states menu should only be used when directed to do so by an authorized technician for HP Systems.

## SCSI command tracking

When this option is selected from the System Utilities menu, the SCSI Command Tracking menu is displayed (see [Figure 71](#)).

**Figure 71** SCSI Command Tracking menu

```
SCSI Command Tracking Menu
X.XX.XX XXXXXX XXXXXXXXXXXXXXXXXXXX
07/7/2005 15:05:45

1) Turn SCSI Command Tracking OFF
2) Display Available Hosts & Devices
3) Display Command Tracking Info
4) Clear ALL Command Tracking Info
X) Return to previous menu
```

- Select **1** to toggle SCSI Command Tracking ON or OFF. When toggled ON, all SCSI commands received or transmitted to or from the network storage router are logged. When OFF, these commands are not logged. When set to ON, menu options **2** through **4** are also available from this menu.
- Select **2** to display all selected hosts and devices.
- Select **3** to set the data to be displayed in terms of Type (Device, Host, ALL), Protocol (FC, SCSI, Other, ALL), and Specific (ID or ALL). If ID is selected for Specific, this ID can be an FC LUN, Switch ID (S\_ID),



or other ID. SCSI commands which have already been tracked, then that information is displayed by selecting this option.

- Select **4** to clear the log of all previously recorded results.

## Display trace and assertion history

When this option is selected from the main menu, the Trace Dump menu is displayed (see [Figure 72](#)). Trace options are set up in the Trace Settings Configuration menu.

**Figure 72** Trace dump menu

```
Trace Dump Menu
X.XX.XX  XXXXXX  XXXXXXXXXXXXXXXXXXXX
07/7/2005  08:56:22

1) Display trace for current boot cycle
2) Display trace from previous boot cycle
3) Display trace from last assertion failure
4) Clear current trace buffer
5) Clear (flash) assert trace buffer

X) Return to previous menu
```

- Select **1** to display trace history for the current boot cycle.
- Select **2** to display trace history from the previous boot cycle.
- Select **3** to display trace history from the last assertion failure.
- Select **4** to clear the current trace buffer. If cleared, then the **Display trace from current boot cycle** option does not show any data.
- Select **5** to clear the assert trace buffer. If cleared, then the **Display trace from last assertion failure** option does not show any data.

## Get a copy of trace buffer

To save copies of the trace buffers over FTP:

1. Connect the network storage router to the Ethernet network used by your computer.
2. Start your FTP program using the network storage router's IP address:

```
ftp <IP address>
```

---

 **NOTE:** If the IP address of the network storage router is not known or needs to be changed, connect to the network storage router using a serial connection. The current network storage router IP address is displayed and can be changed in the serial Ethernet Configuration menu.

---

The default network setting is DHCP.

---

 **NOTE:** You may also need to specify the directory location on your computer or network where your FTP program stores the trace file.

---

3. Use `root` as the user name and `password` as the password.
4. Specify Bin mode:  

```
bin
```
5. Specify the filename (`.txt` file) with the `get` command.
  - For the current trace buffer, use `get curtrace.txt`.

- For the previous trace buffer, use `get prvtrace.txt`.  
The file transfers from the network storage router.

## Reboot

When this option is selected, a confirmation message appears to verify the selection. If a response of **Y** (yes) is given to the confirmation message, current network storage router activities are disrupted while the unit restarts itself. The last saved configuration changes also take effect after the network storage router powers on again.

## Download a new revision of the firmware

When this option is selected, a confirmation message appears to verify the selection. If a response of **Y** (yes) is given to the confirmation message, current network storage router activities are interrupted while the unit begins accepting the new firmware from the serial port.

To download firmware using a terminal or terminal emulator connected to the serial port of the network storage router:

1. From the Main menu, select the **Download a New Revision of the Firmware** option to start the download procedure.
2. When you confirm you want to download, the network storage router starts the download process.
3. Use the **Transfer > Send File** option in the terminal emulator utility.
4. Select the location of the firmware. Use the **Browse** button, if you need help finding it.
5. The download transfer protocol should use 1K XMODEM, if the terminal emulator supports it. Otherwise, use just XMODEM as the transfer protocol.
6. Press the **Send** button. The firmware begins to download to the network storage router.

When the download process is complete, the system verifies that the firmware image was successfully written to the FLASH memory and then reboots the network storage router. Upon reboot, the network storage router detects that there is a newly downloaded firmware image, copies that image to the boot sector of the FLASH, and then boots with that image. At that point, the network storage router is using the new firmware.

Figure 73 shows what you could see on your terminal when you download a new revision of the firmware:

Figure 73 Download firmware menu

```

Download Firmware Menu
X.XX.XX XXXXXX XXXXXXXXXXXXXXXXXXXX
07/7/2005 08:56:22

This replaces the current revision of the firmware.
A reboot is also performed as part of this process.

Are you sure (y/n)? Y.

Please begin symptom file transfer...
$$$$$$$$$

D O W N L O A D   C O M P L E T E
*****
...* Start System Cold Reboot!

```

## 7 Using the FTP interface

This chapter describes specific management options available from the FTP interface. For an overview of using the other management interfaces available, see “[N1200-320 4Gb Network Storage Router management](#)” on page 27.

### Backup/restore configuration settings

The network storage router supports backup and restore of configuration settings over FTP. This allows users to maintain multiple setting configurations externally from the network storage router and to be able to restore any of the configurations as needed. When backing up, configurations are saved from flash to a binary file.

#### Configuration backup procedure

1. Connect the network storage router to the Ethernet network used by your computer.
2. Start your FTP program using the network storage router’s IP address:

```
ftp <IP address>
```

---

 **IMPORTANT:** The network settings set to use DHCP need to be set to default. If the IP address is not known, use the serial interface to obtain the network settings. See “[Setting up serial port communications](#)” on page 18.

---

 **NOTE:** You may also need to specify the directory location on your computer or network where your FTP program will store the backup file.

---

3. Enter the user name and password. The default values for user name and password are **root** for the user name and **password** for the password.
4. Specify binary mode:

```
bin
```

5. Specify the filename (.cfg file) with the `get` command:

```
get filename.cfg
```

(where “*filename.cfg*” can be any name for the configuration file.)

The file will transfer to the current directory specified on your computer’s FTP utility. If running FTP from a DOS or Linux command line, the destination directory can be set using the `lcd` command (ex. `lcd c:\myCfg`).

---

 **NOTE:** World Wide Name (WWN) values and Ethernet physical address (MAC address) values will not be saved. Because user defined values for these settings are not retained in the configuration backup file, they must be re-entered after the configuration is restored.

---

#### Configuration restore procedure

1. Connect the network storage router to the Ethernet network used by your computer.
2. Start your FTP program using the network storage router’s IP address:

```
ftp <IP address>
```

---

 **IMPORTANT:** The network settings set to use DHCP need to be set to default. If the IP address is not known, use the serial interface to obtain the network settings. See “[Setting up serial port communications](#)” on page 18.

---

---

 **NOTE:** If the network storage router is to use a static IP address, the pre-filled in address when DHCP is disabled is 1.1.1.1 and should be changed to an address that is appropriate for the IP network it will reside on.

---

3. Enter the user name and password. The default values for user name and password are **root** for the user name and **password** for the password.
  4. Specify binary mode:  
`bin`
  5. Specify the configuration's path and filename (.cfg file) with the `put` command:  
`put <path>\filename.cfg>`  
The file will transfer and the network storage router will reboot. The network storage router will then be using the configuration.
- 

 **NOTE:** World Wide Name (WWN) values and Ethernet physical address (MAC address) values will revert to the factory default settings. Any user defined values for these settings are not retained and must be re-entered after a configuration is restored. See "[Configuration backup procedure](#)" on page 91 for more information.

---

 **NOTE:** Confirm the new configuration by checking that the settings are correct.

---

## Get a copy of trace buffer or event log

Using the following procedure, you can save copies of the trace buffers or event log over FTP.

1. Connect the network storage router to the ethernet network used by your computer.
2. Start your FTP program using the network storage router's IP address:

```
ftp <IP address>
```

---

 **IMPORTANT:** The network settings set to use DHCP need to be set to default. If the IP address is not known, use the serial interface to obtain the network settings. See "[Setting up serial port communications](#)" on page 18.

---

 **NOTE:** You may also need to specify the directory location on your computer or network where your FTP program will store the trace file.

---

 **NOTE:** If the network storage router is to use a static IP address, the pre-filled in address when DHCP is disabled is 1.1.1.1 and should be changed to an address that is appropriate for the IP network it will reside on.

---

3. Enter the user name and password. The default values for user name and password are **root** for the user name and **password** for the password.
4. Specify Bin mode:  
`bin`
5. Specify the filename (.txt file) with the `get` command.
  - For the current trace buffer, use `get curtrace.txt`.
  - For the previous trace buffer, use `get prvtrace.txt`.
  - For the assert trace buffer, use `get assertlog.txt`.

- For the current event log, use `get eventlog.txt`.

The file will transfer to the current directory specified on your computer's FTP utility. If running FTP from a DOS or Linux command line, the destination directory can be set using the `lcd` command (ex. `lcd c:\myCfg`).

## Updating firmware

Using the following procedure, FTP can be used to update the network storage router firmware.

1. Connect the network storage router to the Ethernet network used by your computer.
2. Start your FTP program using the network storage router's IP address:

```
ftp <IP address>
```

---

 **IMPORTANT:** The network settings set to use DHCP need to be set to default. If the IP address is not known, use the serial interface to obtain the network settings. See "[Setting up serial port communications](#)" on page 18.

---

 **NOTE:** If the network storage router is to use a static IP address, the pre-filled in address when DHCP is disabled is 1.1.1.1 and should be changed to an address that is appropriate for the IP network it will reside on.

---

3. Enter the user name and password. The default values for user name and password are **root** for the user name and **password** for the password.

4. Specify binary mode:

```
bin
```

5. Specify the firmware's path and filename (.dlx file) with the `put` command:

```
put <path\filename.dlx>
```

The file will transfer and the network storage router will reboot. The network storage router will then be using the new firmware.

---

 **NOTE:** You may want to confirm the new firmware level by checking the reboot messages on the network storage router through the serial interface.

---



## 8 Troubleshooting

Various problems can arise when configuring and using the HP N1200-320 4Gb Network Storage Router. This section is provided to help guide the user through some of the basic methods of identifying faults in the setup and configuration of the network storage router.

Most problems are found in the initial installation. In general, it is wise to check all connections and review the configuration before proceeding with further trouble analysis. Simplify the installation if possible, reducing it to the most basic configuration, then adding elements one at a time and verifying the operation at each step.

### General troubleshooting

#### What happens if the DHCP server cannot be contacted?

- **Serial Interface:** the following occurs over the serial line: the following text appears above the HP Systems Main menu within the terminal window, "Attempting to contact DHCP server..." After about 3 minutes, the following message appears, "Can't renew DHCP boot lease."
- **Within Telnet:** the user will see only a blank Telnet window which is not accessible. Instead of an IP address value displaying in upper left heading of Telnet window, "(None)" appears instead. Within half a minute, Telnet will produce a warning message stating "Connect Failed!"
- **Within Visual Manager:** the user will be able to submit a new Web page and reboot (as is typically the case). However, since the DHCP isn't contacted, a new IP address will not be generated after reboot. Therefore, Visual Manager will no longer be useful since no IP address is available. The previous non-DHCP will not work either. Visual Manager will time out and provide a warning message to the user stating that "a connection with server could not be established."

In the above situations, perform the following:

1. Check on the status of the DHCP server with your network administrator,
2. Ensure the Ethernet link (LNK) light on the network storage router is green (and if not check that the Ethernet cable is securely connected).
3. Check the configuration of the network storage router, including the gateway address, and assign values manually, if needed.

If the above list all appear to be in order, but DHCP is still not working, attempt to reset the network storage router to factory defaults (any current configuration settings will be reset), reboot the network storage router, and then reconfigure the network storage router as desired. If problems persist, see "Technical support" on page 99.

### Indicators

The network storage router is equipped with LED indicators for monitoring overall unit status (see [Figure 74](#) on page 96). The LED functionality of the network storage router is detailed below:

- **Power and Fault (PWR)**—This indicator is a bi-color LED. When green, this indicator shows that power is currently active. Lack of power indication suggests that the unit is turned off, a problem with the power supplied to the unit, or an internal problem with the unit. When this indicator is amber, this indicator shows that the network storage router detects a fault condition. Faults can occur as a result of Power On Self Test (POST) failure or operational failures. It is normal for this indicator to flash on when the unit is powered up or reset. If the fault indicator stays lit, contact your product support representative.
- **Fibre Channel (LNK/ACT)**—When green, the LNK indicator signifies a good Fibre Channel link on the port. When green, the ACT indicator signifies Fibre Channel port activity. If the LNK indicator fails to light at all, or if the ACT indicator stays continually lit without corresponding activity on a FC device port, there may be a problem with the Fibre Channel configuration. Verify the Fibre Channel configuration.
- **SCSI Bus (0, 1)**—When lit, these green indicators signify SCSI activity on the bus corresponding to the number of the indicator. Activity should only occur briefly during power-up or configuration, and relatively often when the unit is transferring data. If an ACT indicator stays continually lit without

corresponding target device activity, there may be a problem with the SCSI bus configuration. Verify the SCSI bus configuration.

- **Ethernet (10/100)**—The LNK should stay permanently lit to indicate an Ethernet link. The ACT indicator should flash to indicate activity. If either of these indicators fail to flicker, or stay continuously lit, there may be a problem with the network connection or configuration. Verify the network connection and configuration. The port must be connected to a Ethernet network to function properly.

**Figure 74** Operation indicators

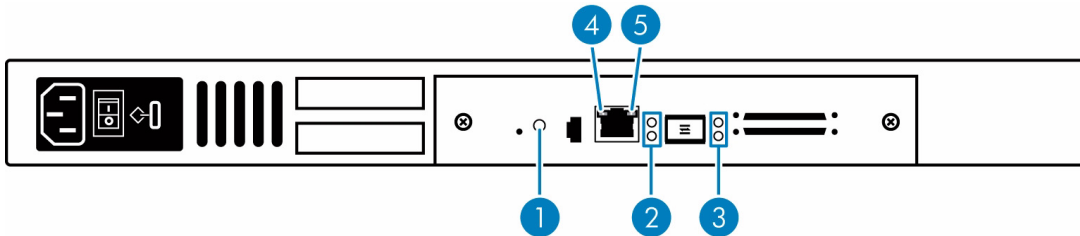

**Table 7** Operation indicators

Number	Description
1	Power LED
2	Fibre Channel port LEDs link (LNK) indicator (top) and activity indicator (ACT) (bottom)
3	SCSI Bus 0, 1 activity LEDs
4	Ethernet LED link (LNK) indicator
5	Ethernet LED activity (ACT) indicator

## Basic verification

### Serial port problems

If you experience trouble communicating with the serial port, verify the configuration of the host terminal or terminal emulation program. The network storage router requires the baud rate to be set correctly: 8 data bits, 1 stop bit, and no parity. Flow control should be set to none or **XON/XOFF**, and may cause problems if set to **hardware**. Some terminal programs may not support baud rates higher than 19200, so a lower baud rate may be required. If problems persist, you may want to check the cabling or try a different host. Be sure the Scroll Lock key on the keyboard of the host computer is not enabled. If a valid Ethernet IP address is configured, serial configuration settings can also be set via telnet.

### Login problems

In a switched fabric environment, if a login problem is experienced, or if the drives can not be seen, confirm that the port settings of the network storage router are set for **auto-sense** or for **N-port**. Using a hard ALPA setting with the N-port setting is not a valid configuration.

### Windows driver

There are no actual device drivers required for the network storage router. When Windows prompts for a device driver, this situation occurs because the Active Fabric LUN of the network storage router is enabled. Solutions to this request for a driver include the following options:

- Disable Active Fabric (or the target LUN for the network storage router, in order to eliminate further Windows driver requests. You can also accept the Windows prompts and disable the device in the device manager.
- Optionally, an HP device driver installation file (called an INF file) is included on the User Documentation CD. The network storage router does not really need an actual driver, as the HBA in the host PC manages this. However, the included INF file does allow the Windows Device Manager to register the network storage router's network storage router LUN as a system device. Thereafter, the Device Manager will no longer consider this network storage router LUN to be an unknown or "newly



discovered” device every time there is a reboot. By using the included INF file, the user just needs to identify the network storage router to the Windows Device Manager only once.

To install (or register) the network storage router to a connected host Windows PC, perform the following steps:

1. Copy the INF file to the Windows PC which has the FC HBA to be connected to the network storage router. Typically, the appropriate location to copy the file is as follows:

```
C:\WINNT\system32\
```

---

 **NOTE:** There must be a network storage router LUN set up on the network storage router so that the Windows operating system can discover it.

---

2. When the network storage router **FC Link** LED indicates a good connection, the user can either reboot the PC or run the Windows Device Manager **Scan for New Hardware** function. Either action should result in the HBA issuing a SCSI Inquiry command, to which the network storage router replies with an ASCII Inquiry string.

---

 **NOTE:** Initially, the Windows Hardware Wizard uses this string to refer to the network storage router. After this discovery interaction occurs, the Hardware Wizard will prompt the user to install a device driver.

---

3. Select the Wizard’s **Search for Better Driver** option and specify the folder containing the network storage router INF file. The Hardware Wizard will scan the specified folder for all INF files and will select the first INF file it finds with a device entry containing a matching hardware ID string.

---

 **NOTE:** The Hardware Wizard will copy the selected INF file, renaming it to **OEM<#>.inf**, where the # is some integer, and it will place the copied file into the **C:\WINNT\inf** folder. The Hardware Wizard will then compile the INF file to a **.PNF** file with the same root filename and use its network storage router model entry information to install, or register, the newly discovered device.

---

4. Reboot the host PC to complete the process, as prompted by the Hardware Wizard.

## Verify SCSI bus configuration

Problems with SCSI bus configuration are common. Basic operation of a SCSI bus can be checked by using the configuration menu to view attached SCSI devices.

Other conditions to look for include:

- **Termination**—Problems with termination can cause intermittent or hard failure. A SCSI bus must be terminated on both ends, and only both ends. Termination issues when both narrow and wide devices are on the same bus are common. Check to make sure that there are no loose terminators. All terminators should be firmly attached.
- **Bus Type**—The SE and LVD devices can be connected to the same SCSI bus; however, on power-up, if at least one SE device is detected, the LVD devices must convert to SE mode, and SE mode will be used. Only the LVD interface is being specified for the Fast/40 and higher rates.
- **Device ID**—Each device on a SCSI bus must have a unique ID. Also check the configured ID’s for the network storage router to verify these are not in use by other devices on the same SCSI bus.
- **Cabling**—Check SCSI cables to verify that they are functional. SCSI rules for total length, distance between devices, and stub length must be adhered to. Connections should also be checked and reseated if necessary. Ensure that the SCSI cables are Multimode or rated for the SCSI speed of the drive.
- **SCSI Devices**—Verify that the SCSI devices on a particular SCSI bus can be seen in the configuration menu of the network storage router. Select **System Utilities > System Statistics > Parallel SCSI Protocol Status > Display Attached SCSI Devices > Display ALL Local Devices**. If the network storage router can not see the devices, verify SCSI configuration, cabling, and termination.

Even if the SCSI devices are displayed, they are not accessible unless the mapping mode is auto-assigned or another non-empty map is used.

## Verify Fibre Channel connection

If SCSI devices are recognized on the SCSI buses, but do not appear to the Fibre Channel host, it may be that the Fibre Channel link is not properly established. Most hubs and switches have link indicators, showing link status. When the network storage router is connected and the library is powered-on, this link indicator should show a good link (see “[Operation indicators](#)” on page 10). If it does not, check the cabling and connections.

As a means of verifying link integrity when connected to a functional host, disconnecting then reconnecting the Fibre Channel cable should cause momentary activity of this indicator as the link itself reinitializes. Also verify that the media type of the network storage router and attached hub, HBA, or switch are of corresponding types. When using optical media, verify that the attached device is using non-OFC type optical devices.

Also, make sure that the network storage router is configured with the same speed as the device it is connected to, and that the host is assigned to a LUN map filled with the devices it should be able to communicate with.

## Verify SCSI devices in Windows NT

If running FC-to-SCSI mapping mode, open the NT Control Panel, select **SCSI Adapters**, and double click on the FC HBA. The SCSI devices should be listed.

If no devices are listed, verify the network storage router configuration, FC HBA configuration, and cabling.

If devices are listed, verify FC HBA mapping mode or AL\_PA addresses on the network storage router.

## Verify configuration

A number of configuration changes may result in an invalid configuration. If you are in doubt about the configuration, restore the network storage router to the factory default configuration and proceed to configure the unit a step at a time, verifying the functionality of the configuration as changes are made.

## Verify mapping

Verify that all desired devices have been discovered and mapped. If using Indexed or SCC mapping, try swapping to Auto-assigned to see if this solves the problem.

---

**NOTE:** HP recommends that you **DO NOT** use Auto-Assigned long-term as it exposes the library and drives to the entire SAN. Instead, a custom map should be created with only the hosts that need to communicate with the library and the drives assigned to it.

---

## Verify devices

It may be useful to connect the SCSI target devices you are attempting to use to the native SCSI interface to verify that the devices are functional. SCSI target devices can be connected to a host SCSI bus to verify they are functional.

## Verify host configuration

In some cases, it may be that the FC host bus adapter or host device driver may not be working properly. Check the configuration of these elements. It may be useful to check the release notes for the driver provided to see if there are any specific issues or required configuration. It may also be useful to ensure that you are using a current version of the host bus adapter driver and firmware.

## PRLI data

The network storage router supports the discovery mechanism. The network storage router returns the PRLI response data as specified in [Table 8](#).

**Table 8** HP N1200-320 4Gb Network Storage Router PRLI response data

Item	Value
PRLI Command Code	0x20
Page Length	0x10
Payload Length	0x10
Type Code	0x8
Type Code Extension	0x0
OPA	0x0
RPA	0x0
IPE	0x1
Response Code	0x1
Originator Process Associator	0x0
Responder Process Associator	0x0
Initiator Function	0x1
Target Function	0x1
Command/Data Mixed Allowed	0x0
Data/Response Mixed Allowed	0x0
Read XFER_RDY Disabled	0x1
Write XFER_RDY Disabled	0x0

## Verify HBA device driver information

Check the HBA device driver **Readme.txt** file for configuration specifics. An HBA may require a different configuration, depending on whether it is connected to a loop or a switch. HBAs typically come with utility programs to view or change their configurations.

## Running diagnostics

You can run a diagnostics wrap test from Diagnostics Mode in the serial interface.

## Technical support

If you are unable to resolve an issue, contact your authorized service representative and ask for technical support.

### HP technical support

Telephone numbers for worldwide technical support are listed on the HP support web site: <http://www.hp.com/support/>.

Collect the following information before calling:

- Technical support registration number (if applicable)
- Product serial numbers
- Product model names and numbers
- Applicable error messages
- Operating system type and revision level
- Detailed, specific questions

For continuous quality improvement, calls may be recorded or monitored.



# A Pin assignments

## DB-9 pin assignments

In conjunction with the pin assignments provided for the 3-pin receptacle on the rear panel of the HP N1200-320 4Gb Network Storage Router, following are the corresponding pin out assignments for a DB-9 serial connector used to connect the other end of the serial cable to a terminal, or a computer running terminal emulation software.

The pin assignments given in [Figure 75](#) for the DB-9 serial connection are in reference to the serial connector at the end of the cable.

 **NOTE:** To connect the network storage router to a host system, use the RS-232 Serial 3-Pin-to-DB-9 cable included in the shipping container for this product.

**Figure 75** Corresponding pin outs of the DB-9 connector

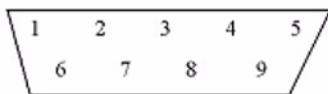

**Table 9** DB-9 connector description

Number	Description
1	No connection
2	RX data (Receive)
3	TX data (Transmit)
4	No connection
5	Signal ground
6	No connection
7	RTS (Request to Send), not used
8	CTS (Clear to Send), not used
9	No connection

## RJ-45 Ethernet Pin Assignments

The pin assignments given for the RJ-45 Ethernet connection are in reference to the Ethernet receptacle on the back panel of the HP N1200-320 4Gb Network Storage Router. The HP N1200-320 4Gb Network Storage Router Ethernet connection supports the IEEE specifications for 10BASE-T and 100BASE-TX Ethernet standards.

**Figure 76** RJ-45 pin assignments

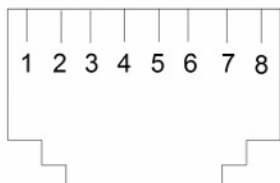

**Table 10** RJ-45 pin descriptions

Number	Description
1	Transmit out +
2	Transmit out -
3	Receive in +
4	No connection
5	No connection
6	Receive in -
7	No connection
8	No connection

---

# B Regulatory compliance and safety

## Regulatory compliance

### Regulatory compliance identification numbers

For the purpose of regulatory compliance certifications and identification, your product has been assigned a unique Regulatory Model Number. The RMN can be found on the product nameplate label, along with all required approval markings and information. When requesting compliance information for this product, always refer to this RMN. The Regulatory Model Number should not be confused with the marketing name or model number of the product.

### Regulatory compliance label location

The Regulatory Compliance label for the HP N1200-320 4Gb Network Storage Router is located on the bottom of the network storage router.

**Regulatory model number:** EO 1011

**Emissions classification:** Class A

### Federal Communications Commission notice

Part 15 of the Federal Communications Commission (FCC) Rules and Regulations has established Radio Frequency (RF) emission limits to provide an interference-free radio frequency spectrum. Many electronic devices, including computers, generate RF energy incidental to their intended function and are, therefore, covered by these rules. These rules place computers and related peripheral devices into two classes, A and B, depending upon their intended installation. Class A devices are those that may reasonably be expected to be installed in a business or commercial environment. Class B devices are those that may reasonably be expected to be installed in a residential environment (such as personal computers). The FCC requires devices in both classes to bear a label indicating the interference potential of the device as well as additional operating instructions for the user.

The rating label on the device shows which class (A or B) the equipment falls into. Class B devices have an FCC logo or FCC ID on the label. Class A devices do not have an FCC logo or FCC ID on the label. Once the class of the device is determined, refer to the following corresponding statement.

#### Class A equipment

This equipment has been tested and found to comply with the limits for a Class A digital device, pursuant to Part 15 of the FCC Rules. These limits are designed to provide reasonable protection against harmful interference when the equipment is operated in a commercial environment. This equipment generates, uses, and can radiate radio frequency energy and, if not installed and used in accordance with the instructions, may cause harmful interference to radio communications. Operation of this equipment in a residential area is likely to cause harmful interference, in which case the user is required to correct the interference at personal expense.

#### Class B equipment

This equipment has been tested and found to comply with the limits for a Class B digital device, pursuant to Part 15 of the FCC Rules. These limits are designed to provide reasonable protection against harmful interference in a residential installation. This equipment generates, uses, and can radiate radio frequency energy and, if not installed and used in accordance with the instructions, may cause harmful interference to radio communications. However, there is no guarantee that interference will not occur in a particular installation.

If this equipment does cause harmful interference to radio or television reception, which can be determined by turning the equipment off and on, the user is encouraged to try to correct the interference by one or more of the following measures:

- Reorient or relocate the receiving antenna.
- Increase the separation between the equipment and receiver.

- Connect the equipment into an outlet on a circuit that is different from that to which the receiver is connected.
- Consult the dealer or an experienced radio or television technician for help.

## Declaration of conformity for products marked with the FCC logo, United States only

This device complies with Part 15 of the FCC Rules. Operation is subject to the following two conditions: (1) this device may not cause harmful interference, and (2) this device must accept any interference received, including interference that may cause undesired operation.

For questions regarding your product, visit <http://www.hp.com>.

For questions regarding this FCC declaration, contact us by mail or telephone:

- Hewlett-Packard Company  
P.O. Box 692000, Mailstop 510101  
Houston, Texas 77269-2000
- 1-281-514-3333

To identify this product, refer to the part, Regulatory Model Number, or product number found on the product.

## Modifications

The FCC requires the user to be notified that any changes or modifications made to this device that are not expressly approved by Hewlett-Packard Company may void the user's authority to operate the equipment.

## Cables

Connections to this device must be made with shielded cables with metallic RFI/EMI connector hoods in order to maintain compliance with FCC Rules and Regulations.

## Laser device

All HP systems equipped with a laser device comply with safety standards, including International Electrotechnical Commission (IEC) 825. With specific regard to the laser, the equipment complies with laser product performance standards set by government agencies as a Class 1 laser product. The product does not emit hazardous light.

## Laser safety warning

---

**⚠ WARNING!** To reduce the risk of exposure to hazardous radiation:

- Do not try to open the laser device enclosure. There are no user-serviceable components inside.
  - Do not operate controls, make adjustments, or perform procedures to the laser device other than those specified herein.
  - Allow only HP authorized service technicians to repair the laser device.
-



## International notices and statements

### Canadian notice (avis Canadien)

#### Class A equipment

This Class A digital apparatus meets all requirements of the Canadian Interference-Causing Equipment Regulations.

Cet appareil numérique de la classe A respecte toutes les exigences du Règlement sur le matériel brouilleur du Canada.

#### Class B equipment

This Class B digital apparatus meets all requirements of the Canadian Interference-Causing Equipment Regulations.

Cet appareil numérique de la classe B respecte toutes les exigences du Règlement sur le matériel brouilleur du Canada.

### European Union notice

Products bearing the CE marking comply with the EMC Directive (89/336/EEC) and the Low Voltage Directive (73/23/EEC) issued by the Commission of the European Community and if this product has telecommunication functionality, the R&TTE Directive (1999/5/EC).

Compliance with these directives implies conformity to the following European Norms (in parentheses are the equivalent international standards and regulations):

- EN55022 (CISPR 22) - Electromagnetic Interference
- EN55024 (IEC61000-4-2, IEC61000-4-3, IEC61000-4-4, IEC61000-4-5, IEC61000-4-6, IEC61000-4-8, IEC61000-4-11) - Electromagnetic Immunity
- Power Quality:
  - EN61000-3-2 (IEC61000-3-2) - Power Line Harmonics
  - EN61000-3-3 (IEC61000-3-3) - Power Line Flicker
- EN60950-1 (IEC60950-1) - Product Safety
- Also approved under UL 60950-1/CSA C22.2 No. 60950-1, Safety of Information Technology Equipment.

### BSMI notice

#### 警告使用者:

這是甲類的資訊產品，在居住的環境中使用時，可能會造成射頻干擾，在這種情況下，使用者會被要求採取某些適當的對策。

## Japanese notice

ご使用になっている装置にVCCIマークが付いていましたら、次の説明文をお読み下さい。

この装置は、情報処理装置等電波障害自主規制協議会（VCCI）の基準に基づくクラスB情報技術装置です。この装置は、家庭環境で使用することを目的としていますが、この装置がラジオやテレビジョン受信機に近接して使用されると、受信障害を引き起こすことがあります。

取扱説明書に従って正しい取り扱いをして下さい。

VCCIマークが付いていない場合には、次の点にご注意下さい。

この装置は、情報処理装置等電波障害自主規制協議会（VCCI）の基準に基づくクラスA情報技術装置です。この装置を家庭環境で使用すると電波妨害を引き起こすことがあります。この場合には使用者が適切な対策を講ずるよう要求されることがあります。

## Korean notices

### A급 기기 (업무용 정보통신기기)

이 기기는 업무용으로 전자파적합등록을 한 기기이오니 판매자 또는 사용자는 이 점을 주의하시기 바라며, 만약 잘못판매 또는 구입하였을 때에는 가정용으로 교환하시기 바랍니다.

### B급 기기 (가정용 정보통신기기)

이 기기는 가정용으로 전자파적합등록을 한 기기로서 주거지역에서는 물론 모든지역에서 사용할 수 있습니다.

## Safety

### Battery statement

---

⚠ **WARNING!** This product contains one lithium manganese dioxide battery.

- The N1200-320 4Gb Network Storage Router contains one Snapat® lithium battery.
- The lithium battery is located in the upper left corner of the board, is yellow in color, and can be removed with a flat blade screwdriver.

Lithium may be considered a hazardous material. Dispose of these batteries in accordance with local, state, and federal laws. In addition:

- Do not attempt to recharge the battery if removed from the network storage router.
- Do not expose the battery to water or to temperatures higher than 60°C (140°F).
- Do not disassemble, crush, puncture, short external contacts, or dispose of in fire or water.
- Replace batteries only with the designated HP spares.

Batteries, battery packs, and accumulators should not be disposed of together with general household waste. To forward them to recycling or proper disposal, use the public collection system or return them to HP, an authorized HP Partner, or their agents.

For more information about battery replacement or proper disposal, contact an authorized reseller or an authorized service provider.

---

## Taiwan battery recycling notice



廢電池請回收

The Taiwan EPA requires dry battery manufacturing or importing firms in accordance with Article 15 of the Waste Disposal Act to indicate the recovery marks on the batteries used in sales, giveaway or promotion. Contact a qualified Taiwanese recycler for proper battery disposal.



## C Inband SCSI-3 commands

The HP N1200-320 4Gb Network Storage Router supports a set of SCSI-3 commands that can be received inband over FCP. When received by the network storage router, these commands are then executed by the network storage router itself.

When using SCSI-3 commands to access general management features, the commands can be sent to device LUNs that are mapped through the network storage router.

The following is a list of the SCSI-3 commands that are supported by the network storage router. Complete definitions of SCSI-3 commands can be found in the SCSI-3 standard available from the American National Standards Institute (ANSI).

### General Commands

- REPORT LUNS
- INQUIRY

## General commands

Following is a description of a general-use SCSI-3 command. For more information about the other general-use commands, please contact your service representative.

## Report LUNs command

The network storage router supports the Report LUNs command. The Report LUNs command will return a list of Logical Unit Numbers (LUNs) that can receive commands. The format of the report LUNs command is shown in [Table 11](#).

**Table 11** Format of Report LUNs command

Bit	7	6	5	4	3	2	1	0
0	Operation Code ( 0xA0)							
1	Reserved							
2	Reserved							
3	Reserved							
4	Reserved							
5	Reserved							
6	(MSB)							
7	Allocation Length							
8								
9								
	(LSB)							
10	Reserved							
11	Control Byte							

The network storage router returns the LUN Parameters as defined in [Table 12](#).

**Table 12** Report LUNs Parameter List

Bit	7	6	5	4	3	2	1	0
Byte								
0	(MSB)							
1	LUN list length							
2								
3	(LSB)							
4	Reserved							
5	Reserved							
6	Reserved							
7	Reserved							

LUN list	
0-7	First LUN
	:
0-7	Last LUN

---

 **NOTE:** The LUN list length is the number of LUNs times 8.

---

All LUNs are reported and will appear in the host's map.

## Inquiry command

The format of the Inquiry command is shown in [Table 13](#).

**Table 13** Format of LUN Inquiry command

Bit	7	6	5	4	3	2	1	0
Byte								
0	Operation Code (12h)							
1	Reserved						EVPD	
2	Page Code or Operation Code							
3	Reserved							
4	Allocation Length							
5	Control							

The network storage router returns the LUN Inquiry Data as defined in [Table 15](#).

## EVPD Page 0x80

If the EVPD bit is set and the Page Code is 0x80 the *unit serial number page* is returned. The format of this page is shown in [Table 14](#).

**Table 14** Format of EVPD Page 0x80

Bit	7	6	5	4	3	2	1	0
Byte								
0	Device Type (0ch)							
1	Page Code (80h)							
3	Reserved							
4	Page Length							
5...20	Serial Number							

The serial number field is a 16-byte left-justified ASCII string.

## Device Identification Page 0x83

If the EVPD bit is set and the Page Code is 0x83 the *device identification page* is returned, as described in SPC-2 section 8.4.4.

**Table 15** HP N1200-320 4Gb Network Storage Router LUN Inquiry Data

Item	Value
Peripheral Qualifier	0x00
Peripheral Device Type	0x0C - Indicates Router/network storage router function
RMB	0x00
Device Type Qualifier	0x00
ISO Version	0x00
AENC	0x00
TrmLOP	0x00
Response Data Format	0x02 - SCSI-2 Inquiry Data Format
Additional Length	0x20
RelAdr	0x00
Wbus32	0x00
Wbus16	0x00
Sync	0x00
Linked	0x00
CmdQue	0x00
SftRe	0x00
Vendor ID	"CROSSRDS"
Product ID	"network storage router network storage router"
Revision Level	"XXXXX"

The network storage router will only reply to a SCSI Inquiry when using 8-byte LUN field of 0x00's.

---

 **NOTE:** The Revision Level comes from the last four characters of the build string, which appears in the headings for most menu screens.

---



## D Addressing, structures, and operations

Fibre Channel and SCSI systems employ different methods of addressing devices. The inclusion of a network storage router requires that a method of translating device IDs be implemented so that each SCSI device is mapped to the appropriate Fibre Channel LUN. The SCSI buses establish bus connections between devices. Targets on a SCSI bus may internally address logical units. The addressing of a specific SCSI device is represented by the BUS:TARGET:LUN triplet.

When a Fibre Channel initiator initializes on a loop, the host must first determine what devices exist on the loop. Device discovery is performed, and an FCP target device list is built. Each device is queried for FCP logical units. The logical units are the actual devices that the operating system will address. When an initiator addresses a logical unit, the LUN field used is consistent in form with the SCC defined fields. All current Fibre Channel host bus adapter drivers are consistent with these methods. The addressing used is the SCC Logical Unit Addressing and Peripheral Device Addressing methods, shown in [Table 16](#) and [Table 17](#). First level addressing is supported, so only the first 2 bytes of the 8-byte FCP LUN are used.

**Table 16** SCC addressing structure

Bit	7	6	5	4	3	2	1	0
<b>Byte</b>								
N	Address Method		Address Method Specific					
N+1	Address Method Specific							

**Table 17** Address method definitions

Codes	Description
00	Peripheral Device Addressing Method
01	Volume Set Addressing Method
10	Logical Unit Addressing Method
11	Reserved

**Table 18** SCC logical unit addressing

Bit	7	6	5	4	3	2	1	0
<b>Byte</b>								
N	1	0	Target					
N+1	Bus		LUN					

**Table 19** Peripheral device addressing

Bit	7	6	5	4	3	2	1	0
<b>Byte</b>								
N	0	0	Bus					
N+1	Target/LUN							

The network storage router supports the Peripheral Device Addressing Method and the Logical Unit Addressing Method, depending on the configuration.

**Table 20** Arbitrated Loop Node number to AL\_PA lookup table

0:0x01	21:0x2E	42:0x52	63:0x74	84:0xA6	105:0xC9
1:0x02	22:0x31	43:0x53	64:0x75	85:0xA7	106:0xCA
2:0x04	23:0x32	44:0x54	65:0x76	86:0xA9	107:0xCB
3:0x08	24:0x33	45:0x55	66:0x79	87:0xAA	108:0xCC
4:0x0F	25:0x34	46:0x56	67:0x7A	88:0xAB	109:0xCD
5:0x10	26:0x35	47:0x59	68:0x7C	89:0xAC	110:0xCE
6:0x17	27:0x36	48:0x5A	69:0x80	90:0xAD	111:0xD1
7:0x18	28:0x39	49:0x5C	70:0x81	91:0xAE	112:0xD2
8:0x1B	29:0x3A	50:0x63	71:0x82	92:0xB1	113:0xD3
9:0x1D	30:0x3C	51:0x65	72:0x84	93:0xB2	114:0xD4
10:0x1E	31:0x43	52:0x66	73:0x88	94:0xB3	115:0xD5
11:0x1F	32:0x45	53:0x67	74:0x8F	95:0xB4	116:0xD6
12:0x23	33:0x46	54:0x69	75:0x90	96:0xB5	117:0xD9
13:0x25	34:0x47	55:0x6A	76:0x97	97:0xB6	118:0xDA
14:0x26	35:0x49	56:0x6B	77:0x98	98:0xB9	119:0xDC
15:0x27	36:0x4A	57:0x6C	78:0x9B	99:0xBA	120:0xE0
16:0x29	37:0x4B	58:0x6D	79:0x9D	100:0xBC	121:0xE1
17:0x2A	38:0x4C	59:0x6E	80:0x9E	101:0xC3	122:0xE2
18:0x2B	39:0x4D	60:0x71	81:0x9F	102:0xC5	123:0xE4
19:0x2C	40:0x4E	61:0x72	82:0xA3	103:0xC6	124:0xE8
20:0x2D	41:0x51	62:0x73	83:0xA5	104:0xC7	125:0xEF

The data shown in [Table 20](#) comes from the Fibre Channel Configuration Menu (setting the AL\_PA value) on the network storage router. The user enters the node number (number to the left of the colon from [Table 20](#)) and the network storage router translates the node number into the corresponding AL\_PA value (number to the right of the colon in [Table 20](#)).

## Auto Assigned addressing option

The Auto Assigned option is similar to the Indexed addressing, but with the distinction that the table used is created through SCSI device discovery on power-up or reset, and not otherwise retained. As the unit performs device discovery on the SCSI bus, the Index table FCP LUN values are filled with adjacent FCP LUNs referencing each subsequent SCSI device. The host system will then detect every attached SCSI device without voids, allowing full device discovery to the host. This allows easy configuration in environments where SCSI device ordering is not important, and where hot plugging of SCSI devices will not occur. Configuration options provide for the SCSI discovery to be performed in order of bus, target, or LUN as desired for the specific environment.

## Indexed addressing option

Indexed Addressing allows for host bus adapter (HBA) drivers that only use Peripheral Device addressing to access SCSI devices attached to the network storage router. This is done by use of a table, which is indexed by sequential LUN values, indicating selected BUS:TARGET:LUN devices. It is not possible in this mode to address the network storage router as a network storage router unit directly. The table has the structure as shown in [Table 21](#).

The maximum size of the table is equal to the number of buses times the number of targets per bus, less one initiator ID per bus, times the number of LUNs per target.

The index table can be manually edited. A method is also provided to perform SCSI device discovery, and fill the table in the order that SCSI devices are discovered on the SCSI buses.

**Table 21** Indexed addressing table

FCP LUN Value	SCSI BUS:TARGET:LUN
0	0:0:0
1	0:1:0
2	0:2:0
3	0:3:0
4	0:4:0
5	0:5:0
6	0:6:0
	(0:7:0 occupied by Initiator ID)
7	0:8:0
(...)	(...)
13	0:14:0
14	0:15:0
15	1:0:0
16	1:1:0
17	1:2:0
(...)	(...)

## SCC addressing option

When a network storage router device is configured to use SCSI network storage router Commands (SCC) addressing, the unit is capable of responding as a network storage router device to the FCP Initiator, or routing the FCP request to a specified BUS:TARGET:LUN. When a request using the Peripheral Device addressing method is received (an FCP command with the LUN field with bits 7 and 6 of byte 0 are set to 0), the unit routes the request to the internal processor, which acts on the command directly. When a request using the Logical Unit addressing method is received (bits 7 and 6 set to 10b), the request is routed to the BUS:TARGET:LUN as specified in the defined field.

Host systems using SCC addressing will typically do initial device discovery using the Peripheral Device addressing method. On issuing an INQUIRY command to the network storage router, the host will receive the network storage router Inquiry data, indicating the device type as a network storage router device (Inquiry data indicates device type is 0xC). The host will then know, on this basis, that subsequent commands to network storage router attached devices will use the Logical Unit addressing method.

The host can perform discovery by either walking through the BUS:TARGET:LUN values as would a standard SCSI driver, or by issuing a REPORT LUNS command. This command is sent to the network storage router (using the Peripheral Device addressing method), and the network storage router returns a table indicating attached devices. The host can then perform actions on these network storage router

attached devices directly without having to perform discovery by issuing commands through all possible combinations.

# E Enabling DHCP on the HP N1200-320 4Gb Network Storage Router

DHCP, or Dynamic Host Configuration Protocol, is an open industry standard that simplifies administering networks based on Transmission Control Protocol/Internet Protocol (TCP/IP). DHCP allows network resources to go farther by enabling a unique IP address to be assigned to a specific device (network storage router, client host, etc.) on a non-permanent, dynamic basis.

DHCP makes network administration easier—the larger the network, the greater the benefit. DHCP accommodates larger networks because it can assign temporary IP addresses for a specified time interval. DHCP frees network administrators from having to configure each network storage router or host manually.

Other benefits of a DHCP environment include:

- No additional address configuration is required for client hosts.
- IP addresses can be reused or leased for specific time periods.
- IP address assignment is better managed. For example, if the IP address for a network storage router in a network changes and 250 client computers have to be updated with the new address, you do not have to manually reconfigure every workstation.

Without DHCP, permanent IP address configuration is the only option. This means a network administrator is required to manually configure a permanent IP address for each individual network storage router or client host. Permanent IP addresses require more network resources, but are useful when dealing with smaller LAN environments. Without dynamic address assignment, network storage routers and hosts have to be configured manually one by one. IP addresses must be managed to avoid duplicate use, and changes must be applied to clients by hand. Configuration information is not centralized, and it is difficult to get a view of all network storage router or host configurations.

The use of TCP/IP and DHCP both contribute to networking and the growth of the Internet. TCP/IP uses open protocol standards that enable the forming of wide area networks (WANs). For each network storage router to identify itself on a TCP/IP network, it must be uniquely identified by the following information:

1. An IP address: a 32-bit field composed of four octets (8-bit numbers from 0 through 255). Each address has decimal notation to separate octet numbers, such as 208.24.132.184.  
Your DHCP server may allow you to set up a lease reservation for an IP address by providing the server with the Ethernet MAC address of the network storage router. This sets the DHCP server to always provide the same IP address to the network storage router. This setup can be useful for remote management of the network storage router via Telnet or Visual Manager. Because the method of setting up a lease reservation varies depending on the DHCP server being used, it is recommended you contact your Network Administrator for assistance.
2. A subnet mask: This indicates how the IP address is to be read. It also indicates how to separate the network identifying information from the network storage router identifying information so the IP address can be interpreted correctly. For example, if a subnet mask of 255.255.255.0 is applied for an address 10.85.189.24, it indicates that the unique network storage router address is 24, located on the 10.85.189 subnetwork.
3. A default gateway: This is used to specify the address for the nearest network storage router that is used by the host device to forward addressed packets on to the network.

These previous three options (IP address, subnet mask, and gateway) are necessary for effective DHCP.

## Setting up DHCP over network storage router interfaces

Network storage routers use three different interfaces which can be used to enable DHCP: Serial, Telnet, and VM. The following will describe how to enable and disable DHCP for each interface.

**NOTE:** Located on the network storage router is a label that displays the unit's Ethernet MAC Address. A network administrator can then use this MAC Address to set up a lease reservation on the DHCP server for the IP address of the network storage router. This effectively allows the network storage router to have a permanent IP address that is assigned by the DHCP server.

### Serial and Telnet interfaces

When the user turns on the library, and thus the network storage router, the system reboots and displays the following Main menu on the terminal window:

**Figure 77** Main menu

```
HP StorageWorks N1200-320 4Gb network storage router
X.X.XX XXXXXX XXXXXX-XXX_XXXXXXXXXXXXXXXXX
07/7/2005 08:56:22

1) Perform Configuration
2) System Utilities
3) Display Trace and Assertion History
4) Reboot
5) Download a New Revision of The Firmware
Copyright (C) 1998 - 2004 Crossroads Systems, Inc. All rights reserved.
Command >
```

- Select **1**. The following menu appears:

**Figure 78** Configuration menu

```
Configuration Menu
X.X.XX XXXXXX XXXXXX-XXX_XXXXXXXXXXXXXXXXX
07/7/2005 08:56:22

1) Baud Rate Configuration
2) Ethernet Configuration
3) Fibre Channel Configuration
4) Parallel SCSI Configuration
5) Device Mapping
6) Trace and Event Settings Configuration
7) Real-Time Clock Configuration
8) Active Fabric Configuration

A) Save Configuration
B) Restore Last Saved Configuration
C) Reset to Factory Defaults
X) Return to main menu
```

- Select **2**. The following menu appears:

**Figure 79** Ethernet configuration menu

```

                                Ethernet Configuration Menu
                                X.X.XX XXXXXX XXXXXX-XXX_XXXXXXXXXXXXXXXXXX
                                07/7/2005 08:56:22

IP Address                      : 1.1.1.1
Subnet Mask                     : 255.255.255.0
IP Gateway                      : 0.0.0.0
Ethernet Physical Address       : 08:06:07:05:03:09
Ethernet Mode                   : 10/100Mbps (Auto-Neg)
Hostname                       :
DHCP Configuration              : Disabled

1) Change IP Address
2) Change IP Subnet Mask
3) Change IP Gateway
4) Change Ethernet Physical Address
5) Toggle Ethernet Mode
6) Change Hostname
7) Toggle DHCP Configuration
8) Change Security Settings

X) Return to previous menu
```

Select **7** to toggle the DHCP setting. When DHCP is enabled, this activates Dynamic Host Configuration Protocol and allows the network storage router to be assigned a dynamic IP address from a DHCP server located on the Ethernet network used by the network storage router.

For descriptions of other menu selections, refer to "[N1200-320 4Gb Network Storage Router management](#)".

Once DHCP is enabled, it is necessary to **save** the current configuration and **reboot** the network storage router before DHCP will operate.

---

 **NOTE:** For the IP address, Subnet Mask, and IP Gateway address, it is okay to have null values prior to rebooting the network storage router. However, if these settings have null values after a reboot, then this indicates the DHCP Server was unable to acquire the information for that setting. See the note below for more information.

---

Use the following steps to save the current settings and reboot the system:

1. Select **X) Return to previous menu**.
2. Select **A) Save Configuration**.
3. Select **X) Return to previous menu**.
4. Select **4) Reboot**.

After the network storage router finishes rebooting, the Main Menu will appear. DHCP status can be verified from the Ethernet Configuration Menu where DHCP Configuration is indicated as "Enabled" if

DHCP has been successfully activated. Note that the IP Address may also appear different than the former non-DHCP IP Address.

 **NOTE:** To use the DHCP feature, a DHCP server must be operational on the Ethernet network used by the network storage router. If the DHCP feature is used when there is no DHCP server, the standard for DHCP requires that the network storage router wait three minutes for a response from a DHCP server before timing out. During this period, the network storage router menus and functions will not be accessible.

## Special note regarding Ethernet IP, subnet mask, and gateway addresses

Once DHCP is enabled, any “null” readings are acceptable for these 3 options *before reboot*. The Ethernet Configuration Menu will also *not* allow these 3 options to be changed while DHCP is enabled (since they are automatically configured by DHCP). Here’s an example of the “DHCP-enabled” menu:

**Figure 80** Ethernet configuration menu

```

                                Ethernet Configuration Menu
                                X.XX.XX  XXXXXX  XXXXXXXXXXXXXXXXXXXX
                                07/7/2005  08:56:22

IP Address                      : 192.168.60.203 [DHCP]
Subnet Mask                     : 255.255.255.0
IP Gateway                      : 192.168.60.1
Ethernet Physical Address       : 00:E0:02:E3:17:51
Ethernet Mode                   : 10/100Mbps (Auto-Neg)
Hostname                       : network storage router
DHCP Configuration              : Enabled

1) Change IP Address
2) Change IP Subnet Mask
3) Change IP Gateway
4) Change Ethernet Physical Address
5) Toggle Ethernet Mode
6) Change Hostname
7) Toggle DHCP Configuration
8) Change Security Settings

X) Return to previous menu
```



## Visual Manager

To access the network storage router using the Visual Manager interface:

1. Look up the current IP address within the Ethernet Configuration menu using the serial interface.
2. Type the IP address in the Web browser without using “www” or “/” or any other characters or symbols.
3. After entering the IP address, the user should see the Configuration Main menu. **Click** on the **Configuration** link. This will access the Configuration Menu containing CURRENT/NEW readings for DHCP (“Use DHCP”). The following 3 DHCP-relevant options are also listed:
  - Ethernet IP address,
  - Subnet mask, and
  - Gateway IP address.

### Tips for manipulating DHCP within Visual Manager

1. To change the current state of DHCP, change its status to enabled or disabled, **submit** the change and then **reboot**.
2. To **reboot**, click the Reboot link from the main menu, select **Yes** in the confirmation message, and then **submit**.
3. The gateway address should have the same subnetwork (1<sup>st</sup> three bytes) as the IP address. For example, an IP address of 192.168.100.93 may have a gateway of 192.168.100.1. However, an unavailable gateway value appearing under the CURRENT section of the Configuration menu means the DHCP server was unable to get the gateway address. If this happens, contact the network administrator to make sure the DHCP server is providing this information, or manually change the gateway address yourself.

Now you should be able to access the new IP address displayed within the Ethernet Configuration menu using Visual Manager.



---

# Glossary

<b>adapter</b>	A printed circuit assembly that translates data between the FC host processor's internal bus and a different bus, such as SCSI.
<b>address</b>	See SCSI addressing.
<b>addressing mode</b>	Used to create a mapping table that maps devices on the SCSI bus to Fibre Channel logical units.
<b>AL_PA</b>	Arbitrated Loop Physical Address. A unique one-byte valid value, derived and used in an Arbitrated Loop Topology as defined in ANSI specification FC_AL ver 4.5.
<b>arbitrated loop</b>	See Fibre Channel - Arbitrated Loop. (ANSI specification FC_AL ver 4.5)
<b>area</b>	The second byte of the N_Port Identifier.
<b>auto-assigned mapping</b>	A menu item. The auto-addressing option creates a mapping table using devices discovered upon powering up or resetting the network storage router, that is not otherwise retained by the network storage router.
<b>baud</b>	A unit of signaling speed, expressed as the maximum number of times per second the signal can change the state of the transmission line or other medium (units of baud are $\text{sec}^{-1}$ ). Note: With Fibre Channel scheme, a signal event represents a single transmission bit.
<b>bus</b>	A means of transferring data between modules and adapters or between an adapter and SCSI devices. For a SCSI bus definition, see SCSI bus.
<b>channel</b>	A general term for a path on which electronic signals travel.
<b>clusters</b>	Two or more computers sharing the same resources on a communication link.
<b>interface card-to-router</b>	Configuration involving at least two interface cards/routers where one interface card/router is in Initiator Mode and another in Target Mode.
<b>device</b>	See FC Device or SCSI Device.
<b>differential</b>	An electrical signal configuration using a pair of lines for data transfer. The advantage of differential compared to single-ended configuration is a relative high tolerance for common-mode noise and crosstalk when used with twisted pair cables. In layman's terms, this means longer distance.
<b>domain</b>	A FC term describing the most significant byte in the N_Port Identifier for the FC device. It is not used in the FC-SCSI hardware path ID. It is required to be the same for all SCSI targets logically connected to a FC adapter.
<b>exchange</b>	A FC term for the basic mechanism used for managing an operation. An exchange identifies information transfers consisting of one or more related non concurrent sequences that may flow in the same or opposite directions, but always in half duplex mode. An exchange is identified by an OX_ID and an RX_ID.
<b>fabric</b>	An FC term that includes FC Arbitrated Loop, Switched Fabric, and Point-to-Point.
<b>FC</b>	See Fibre Channel.
<b>FC-AL</b>	See Fibre Channel - Arbitrated Loop.
<b>FC adapter</b>	A printed circuit assembly that translates data between the FC host processor's internal bus and the FC link. This is also known as an HBA, or Host Bus Adapter.

<b>FC device</b>	A device that uses Fibre Channel communications.
<b>FC port</b>	An opening at the back of the network storage router that provides a fiber optic connection between the FC adapter and the FC host.
<b>FC-SCSI hardware path ID</b>	<p>A FC term describing a list of values showing the physical hardware path of the FC host to the target device.</p> <p>Format: Bus_Converter/Adapter_Address.Protocol_Type.Area.Port.Bus.Target.LUN</p> <p>Example: 8/4.8.0.0.2.4.0</p>
<b>fiber</b>	A fiber optic cable made from thin strands of glass through which data in the form of light pulses is transmitted (LASER, LED). It is often used for high-speed transmission over medium (200m) to long (10km) distances but it can be used for short distances (<200m).
<b>fibre</b>	A generic FC term used to cover all transmission media types specified in the Fibre Channel Physical Layer standard (FC-PH), such as optical fiber, copper twisted pair, and copper coaxial cable.
<b>fibre channel (FC)</b>	Logically, the Fibre Channel is a bidirectional, full-duplex, point-to-point, serial data channel structured for high performance data communication. Physically, the Fibre Channel is an interconnection of multiple communication ports, called N_Ports, interconnected by a switching network, called a fabric, a point-to-point link, or an arbitrated loop. Fibre Channel is a generalized transport mechanism that has no protocol of its own or native input/output command set, but can transport any existing Upper Level Protocols (ULPs) such as SCSI and IP.
<b>fibre channel - arbitrated loop (FC-AL)</b>	One of three existing Fibre Channel topologies, in which 2 to 126 devices are interconnected serially in a single loop circuit. The arbitrated loop topology supports all classes of service and guarantees in order delivery of frames when the source and destination are on the same loop.
<b>fibre channel protocol for SCSI (FCP)</b>	FCP defines a Fibre Channel mapping layer (FC-4) that uses FC-PH services to transmit SCSI command, data, and status information between a SCSI initiator and a SCSI target. Using FCP enables transmission and receipt of SCSI commands, data and status, across the Fibre Channel using the standard Fibre Channel frame and sequence formats.
<b>frame</b>	The smallest, indivisible unit of information transfer used by Fibre Channel. Frames are used for transferring data associated with a sequence. Frame size depends on the hardware implementation and is independent of the ULP or the application software.
<b>ftp</b>	File Transfer Protocol
<b>gigabit interface connector (GBIC)</b>	A physical component that manages the functions of the FC-0 layer, which is the physical characteristic of the media and interface, including drivers, transceivers, connectors, and cables. Mounts on a FC adapter card and connects the network storage router to a FC host. Also referred to as a Physical Link Module (PLM).
<b>hardware path</b>	See FC-SCSI Hardware Path ID.
<b>host bus adapter (HBA)</b>	See FC Adapter.
<b>HVD</b>	High Voltage Differential
<b>ID</b>	Numerical identifier
<b>indexed addressing</b>	A menu name. It allows for generic Fibre Channel host bus adapters to access SCSI devices attached to the network storage router using a table which is indexed by sequential LUN values.

<b>initiator</b>	A device (usually a host system) that requests an operation to be performed by another device known as a target (usually a peripheral).
<b>initiator mode</b>	Configuration mode of the network storage router in which a Fibre Channel initiator requests operations to be performed by a SCSI target device.
<b>IP</b>	Internet protocol
<b>link</b>	For Fibre Channel, it is a connection between two nodes, each having at least one N_Port (or the other end could be an F-Port), interconnected by a pair of optical or copper links, one inbound and one outbound.
<b>longwave</b>	Lasers or LEDs that emit light with wave lengths around 1300 nm. When using single mode (9 nm) fibre, longwave lasers can be used to achieve lengths greater than 2 km.
<b>loop port (nl_port)</b>	A FC port that supports loops.
<b>LUN</b>	Logical Unit Number or Logical Unit; a subdivision of a SCSI target. For SCSI-2, each SCSI target supports up to sixteen LUNs (LUN-0 to LUN-15). Using LUNs, the FC host can address multiple peripheral devices that may share a common network storage router.
<b>LVD/SE</b>	Low Voltage Differential/Single-Ended
<b>mapping table</b>	A table which is indexed by sequential LUN values, indicating selected BUS:TARGET:LUN devices. It is used by the network storage router to perform Fibre Channel-to-SCSI operations by default.
<b>MB</b>	megabyte. (There are 8 bits in a byte.)
<b>motherboard</b>	The main PCA of the network storage router that provides a physical and logical connection between Fibre Channel and SCSI devices.
<b>multiplexer</b>	A device that allows two or more signals to be transmitted simultaneously on a single channel.
<b>N_port</b>	A FC term defining a "Node" port. A FC-defined hardware entity that performs data communication over the FC link. It is identifiable by a unique Worldwide Name. It can act as an originator or a responder.
<b>N_port identifier</b>	A FC term indicating a unique address identifier by which an N_Port is uniquely known. It consists of a Domain (most significant byte), an Area, and a Port, each 1 byte long. The N_Port identifier is used in the Source Identifier (S_ID) and Destination Identifier (D_ID) fields of a FC frame.
<b>network storage router</b>	An intelligent device within the SAN (storage area network) infrastructure that can handle multiple protocols, such as Fibre Channel and SCSI. The routing decision is based on paths between address mappings among dispersed initiators and targets.
<b>offline</b>	<p>Taking the network storage router offline indicates that all SCSI and FC adapters in the network storage router are offline.</p> <p>Taking a SCSI adapter offline means ending inputs/outputs and suspending all transactions going from the network storage router to the specified SCSI devices. The SCSI adapter is no longer active or available for access.</p> <p>Taking a FC adapter offline means ending inputs/outputs and suspending all transactions going from the network storage router to the specified FC device.</p>

<b>online</b>	For the network storage router, online indicates that at least one adapter in the network storage router is active and available for access.  For a SCSI adapter, online indicates the SCSI adapter is active and available for access and input/output processing.  For a FC adapter, online indicates the FC adapter is active and available for access and input/output processing.
<b>originator</b>	The Fibre Channel N_Port responsible for starting an exchange. A FC originator is comparable to a SCSI initiator.
<b>point-to-point</b>	One of three existing FC topologies, in which two ports are directly connected by a link with no fabric, loop, or switching elements present. The network storage router which uses FC-AL to support Point-to-Point configurations.
<b>port name</b>	A field value under the FC Status Menu; the FC port identifier; a 64-bit value the factory assigns to each FC adapter.
<b>post</b>	See Power On Self Test.
<b>power on self test (POST)</b>	A group of tests run when the network storage router is powered on.
<b>processor</b>	Contains the arithmetic and logic, control, and internal memory units that control the network storage router.
<b>reset SCSI</b>	For a specific SCSI bus, the host clears all inputs and outputs and then resets the bus and all the devices connected to it.
<b>responder</b>	The logical function in an N_Port responsible for supporting the exchange initiated by the originator in another N_Port. A FC responder is comparable to a SCSI target. The network storage router is often the responder.
<b>SAN</b>	Storage Area Network
<b>SCC addressing</b>	A menu item. SCSI-3 network storage router Commands (SCC) addressing is used to address SCSI devices attached to the network storage router using the SCC logical unit addressing method. In SCC addressing mode, the network storage router will respond to FCP commands as a SCC network storage router device.
<b>SCSI</b>	Small Computer System Interface
<b>SCSI adapter</b>	A 16-bit fast/wide SE or Differential or LVD or 8-bit narrow single-ended physical connection between the network storage router and the SCSI devices. Each SCSI adapter supports up to sixteen (for fast/wide) or eight (for narrow) SCSI devices, including itself.
<b>SCSI addressing</b>	A SCSI adapter supports up to 16 devices, including itself. Each device has its own unique SCSI address. The SCSI address of a device dictates the device's priority when arbitrating for the SCSI bus. SCSI address "7" has the highest priority. The next highest priority address is "6" followed by 5, 4, 3, 2, 1, 0, 15, 14, 13, 12, 11, 10, 9, 8, with "8" being the lowest priority address.  The narrow SCSI adapter is factory set to address 7. A narrow SCSI adapter supports up to eight devices, including itself. SCSI address "7" has the highest priority followed by 6, 5, 4, 3, 2, 1, and 0.

<b>SCSI bus</b>	The means of transferring SCSI data between SCSI devices. It is an 8-bit or 16-bit bus that supports up to eight or sixteen devices (including itself), in any mix of initiators and targets, with the limitation that at least one initiator and one target must be present.
<b>SCSI device</b>	A single unit on the SCSI bus, identifiable by a unique SCSI address. A SCSI device can act as an initiator or target. For SCSI-3, each SCSI device supports up to sixteen LUNs.
<b>SCSI port</b>	An opening at the back of the network storage router providing connection between the SCSI adapter and the SCSI bus.
<b>SCSI status</b>	A menu name used to show the number of SCSI devices on the bus.
<b>small formfactor pluggable (SFP)</b>	A physical component that manages the functions of the FC-0 layer, which is the physical characteristic of the media and interface, including drivers, transceivers, connectors, and cables. Mounts on a FC adapter card and connects the network storage router to a FC host.
<b>shortwave</b>	Lasers or LEDs that emit light with wavelengths around 780 nm or 850 nm. When using multimode fibre (50 nm), shortwave lasers can be used with FC links less than 500m. To achieve longer lengths, single-mode fibre is required. The preferred fibre core size is 50 micron as this fibre has large bandwidth so that the distance is limited by the fibre attenuation. A 62.5 micron core size is also supported for compatibility with existing FDDI installations. Fibre of this type has smaller bandwidth and, in this case, the distance is limited by the fibre bandwidth.
<b>speed</b>	A status type in the FC Status Menu showing the speed (1063 Mbps) of the FC adapter.
<b>switched fabric</b>	A FC term describing a switched topology, which is one of the three existing FC topologies. Fabric elements interconnect various N_Ports or NL_Ports and are responsible for frame routing.
<b>TCP</b>	Transmission Control Protocol
<b>target</b>	A device (usually a peripheral) that responds to an operation requested by an initiator (usually a host system). Peripherals are targets, but for some commands (for example, a SCSI COPY command), the peripheral may need to act temporarily as an initiator.
<b>terminator block/termination</b>	An electrical connection at each end of the SCSI bus composed of a set of resistors (or possibly other components). Its function is to provide a pull-up for open collector drivers on the bus, and also impedance matching to prevent signal reflections at the ends of the cable.
	The SCSI bus requires termination at both ends of the bus. One end of the SCSI bus is terminated by the SCSI adapter's internal termination. The other end should have a terminator placed on the SCSI connector on the last SCSI peripheral. If this device is not terminated, data errors may occur.
<b>topology</b>	The physical or logical layout of nodes on a network. FC topologies include Point-to-Point, FC-AL, and Fabric.
<b>view node name</b>	A status type in the FC Status Menu showing the identification of the node.
<b>view port name</b>	A status type in the FC Status Menu showing the identification of the port.
<b>world wide name (WWN)</b>	A Name_Identifier which is worldwide unique, and represented by a 64-bit unsigned binary value.





# Index

## A

addressing 113  
audience 7  
authorized reseller, HP 8  
autobaud 21  
Avis Canadien, regulatory compliance notice 105

## B

batteries  
    Taiwan EPA recycling and disposal 107  
baud rate configuration  
    Visual Manager 35  
BSMI, regulatory compliance notice 105  
buffered tape writes  
    Fibre Channel  
    Visual Manager 43  
bus reset on boot  
    Visual Manager 44

## C

cables  
    FCC compliance statement 104  
    shielded 104  
Canada, regulatory compliance notice 105  
Class A equipment, Canadian compliance statement 105  
Class B equipment, Canadian compliance statement 105  
clock configuration  
    Visual Manager 39  
command line interface 59  
    perform configuration 60  
        active fabric 80  
        baud rate 61  
        device mapping 70  
            add a host 74  
            add an entry 71  
            create an entry 72  
            delete a host 75  
            delete an entry 73  
            edit a host 75  
            remove gaps 73  
Ethernet 62  
Fibre Channel 64  
max SCSI bus speed 69  
parallel SCSI 67  
real-time clock 80  
SCSI initiator 68  
trace and event 77  
    event 78  
    special event 79  
    trace 77

    power-up messages 59  
conventions  
    document 7  
    text symbols 7  
current map, default  
    Fibre Channel  
    Visual Manager 43

## D

date configuration  
    Visual Manager 39  
declaration of conformity 104  
device management 23  
    discovery 24  
        FC arbitrated loop addressing 23  
        hard addressing 23  
        soft addressing 23  
    FC switched fabric 23  
    Fibre Channel 23  
    HBA 24  
    LUN 24  
    SCSI 23  
DHCP 117  
DHCP setup  
    Visual Manager 36  
discovery mode  
    Fibre Channel  
    Visual Manager 42  
    SCSI  
    Visual Manager 44  
display trace and assertion 89  
    copy of trace buffer 89  
disposal, Taiwan EPA battery 107  
document  
    conventions 7  
    related documentation 7  
documentation, HP web site 7

## E

Ethernet connection 20  
European Union, regulatory compliance notice 105  
event log  
    clearing  
        Visual Manager 55  
    configuration of  
        Visual Manager 53  
    viewing  
        Visual Manager 54

## F

FCC (Federal Communications Commission)  
    Class A Equipment, compliance notice 103

- Class B Equipment, compliance notice [103](#)
- declaration of conformity [104](#)
- modifications [104](#)
- Fibre Channel hosts
  - viewing and changing
    - Visual Manager [48](#)
- Fibre Channel maps
  - editing entries
    - Visual Manager [48](#)
  - viewing and changing
    - Visual Manager [48](#)
- Fibre Channel port
  - buffered tape writes
    - Visual Manager [43](#)
  - configuration
    - Visual Manager [42](#)
  - configuration screen, illustrated [42](#)
  - default map
    - Visual Manager [43](#)
  - discovery mode
    - Visual Manager [42](#)
  - performance mode
    - Visual Manager [43](#)
  - port mode
    - Visual Manager [42](#)
- firmware
  - download [90](#)
- FTP
  - accessing
    - Visual Manager [51](#)
- FTP interface [91](#)
  - backup [91](#)
  - backup/restore [91](#)
  - event log [92](#)
  - firmware update [93](#)
  - restore [91](#)
  - trace buffer [92](#)

**G**  
German noise declaration [106](#)

**H**  
help, obtaining [8](#)  
host lists

- editing, Fibre Channel
  - Visual Manager [48](#)

HP

- address for
  - FCC questions [104](#)
  - authorized reseller [8](#)
  - series number [103](#)
  - storage web site [8](#)
  - Subscriber's choice web site [8](#)
  - technical support [8](#)
  - telephone number
    - FCC questions [104](#)

**I**  
I/O configuration

- Visual Manager [41](#)

identifying product components [13](#)

IEC EMC, worldwide regulatory compliance notice [105](#)

inband SCSI-3 commands [109](#)

initiator IDs, SCSI

- Visual Manager [44](#)

IP address

- Visual Manager [36](#)

IP gateway

- Visual Manager [36](#)

**J**  
Japan

- regulatory compliance notice [106](#)

**K**  
Korean, regulatory compliance notice [106](#)

**L**  
laser

- radiation, warning [104](#)
- regulatory compliance notice [104](#)

link status, Fibre Channel

- Visual Manager [42](#)

**M**  
mapping tasks, Fibre Channel

- changing the name of the host
  - Visual Manager [48](#)
- default current map
  - Visual Manager [43](#)
- viewing and changing
  - Visual Manager [48](#)

**N**  
network configuration

- Visual Manager [36](#)

network storage router

- connections [19](#)
- interfaces [19](#)
  - Ethernet [20](#)
  - Fibre Channel [19](#)
  - SCSI [20](#)
  - serial [21](#)
    - autobaud [21](#)

noise declaration, German [106](#)

**O**  
operations [113](#)

**P**  
performance mode, Fibre Channel

- Visual Manager [43](#)

port communications [18](#)

port mode, Fibre Channel

Visual Manager 42

## R

rack stability, warning 8

reboot 90

rebooting

Visual Manager 57

recycling, Taiwan EPA battery 107

regulatory compliance

information number 103

notices

BSMI 105

Canada 105

Class A 103

Class B 103

European Union 105

HP series number 103

IEC EMC statement, worldwide 105

Japan 106

Korean 106

lasers 104

modifications 104

shielded cables 104

related documentation 7

RFI/EMI connector hoods 104

## S

SCSI bus

bus reset on boot

Visual Manager 44

configuration of

Visual Manager 44

discovery settings

Visual Manager 44

initiator and target settings

Visual Manager 44

security configuration

Visual Manager 38

serial port

communications 21

connection 21

series number, regulatory compliance 103

statistics information, viewing

Visual Manager 49

structures 113

subnet mask

Visual Manager 36

Subscriber's choice, HP 8

symbols in text 7

system utilities 81

diagnostics 87

event log 86

FC link control 88

runtime report 86

SCSI command tracking 88

system statistics 82

## T

Taiwan EPA battery recycling and disposal 107

technical support, HP 8

telephone numbers

FCC questions 104

text symbols 7

traces

clearing buffers

Visual Manager 53

configuration of

Visual Manager 52

troubleshooting 95

basic verification 96

configuration 98

devices 98

Fibre Channel 98

HBA 99

host 98

PRLI 98

login 96

mapping 98

SCSI 97

SCSI Win NT 98

serial 96

Windows 96

DHCP server 95

indicators 95

## U

user configuration

Visual Manager 38

utilities configuration

Visual Manager 50

## V

Visual Manager

accessing 31

Active Fabric configuration

number of controller LUNs 37

options 37

baud rate configuration 35

clear current trace buffer screen, illustrated 53

clock configuration 39

current traces screen, illustrated 53

discovery 45

discovery screen, illustrated 45

Ethernet configuration

DHCP 36

IP address 36

IP gateway 36

subnet mask 36

event log

clearing 55

configuration 53

display 54

event log settings screen, illustrated 53

Fibre Channel

buffered tape writes 43

- configuration of [42](#)
- default map [43](#)
- discovery mode [42](#)
- hard AL\_PA [42](#)
- link status [42](#)
- performance mode [43](#)
- port mode [42](#)
- Fibre Channel hosts, viewing and changing [48](#)
- FTP access [51](#)
- FTP utility screen, illustrated [51](#)
- home page [33](#)
- home page, illustrated [33](#)
- I/O configuration [41](#)
- Main menu [33](#)
- Main menu, illustrated [33](#)
- mapping tasks, Fibre Channel
  - viewing and changing [48](#)
- network configuration [36](#)
- Network menu options [36](#)
- network screen, illustrated [36](#)
- Ports menu, illustrated [41](#)
- reboot option [57](#)
- reboot screen, illustrated [57](#)
- reset to factory default screen, illustrated [40](#)
- router image, illustrated [33](#)
- SCSI
  - bus reset on boot [44](#)
  - configuration of [44](#)
  - discovery mode [44](#)
  - initiator IDs [44](#)
  - settings [44](#)
- SCSI bus configuration screen, illustrated [44](#)
- serial configuration [35](#)
- serial screen, illustrated [35](#)
- statistics information, viewing [49](#)
- Statistics menu, illustrated [49](#)
- System menu [34](#)
- System menu, illustrated [34](#)
- trace settings screen, illustrated [52](#)
- traces
  - clearing buffers [53](#)
  - configuration [52](#)
- user configuration [38](#)
- utilities configuration [50](#)
  - options [50](#)
- Utilities menu, illustrated [50](#)

## W

- warning
  - rack stability [8](#)
- warnings
  - lasers, radiation [104](#)
- web sites
  - HP documentation [7](#)
  - HP storage [8](#)
  - HP Subscriber's choice [8](#)

## Free Manuals Download Website

<http://myh66.com>

<http://usermanuals.us>

<http://www.somanuals.com>

<http://www.4manuals.cc>

<http://www.manual-lib.com>

<http://www.404manual.com>

<http://www.luxmanual.com>

<http://aubethermostatmanual.com>

Golf course search by state

<http://golfingnear.com>

Email search by domain

<http://emailbydomain.com>

Auto manuals search

<http://auto.somanuals.com>

TV manuals search

<http://tv.somanuals.com>