



User's Guide

HP Vectra VA

6/xxx



Notice

The information contained in this document is subject to change without notice.

Hewlett-Packard makes no warranty of any kind with regard to this material, including, but not limited to, the implied warranties of merchantability and fitness for a particular purpose. Hewlett-Packard shall not be liable for errors contained herein or for incidental or consequential damages in connection with the furnishing, performance, or use of this material.

Hewlett-Packard assumes no responsibility for the use or reliability of its software on equipment that is not furnished by Hewlett-Packard.

This document contains proprietary information that is protected by copyright. All rights are reserved. No part of this document may be photocopied, reproduced, or translated to another language without the prior written consent of Hewlett-Packard Company.

Centronics® is a registered trademark of Centronics Data Computer Corporation.

Microsoft® and MS-DOS® are registered trademarks of Microsoft Corporation. Microsoft Windows®, and Windows® 95 are products of Microsoft Corporation.

OS/2 is a registered trademark of International Business Machines corporation.

Novell® and NetWare® are U.S. registered trademarks of Novell, Inc. PENTIUM™ is a trademark of Intel Corporation.

UNIX® is a registered trademark of UNIX System Laboratories Inc. in the U.S.A. and other countries.

Hewlett-Packard France
Grenoble Personal Computer Division
Technical Marketing
38053 Grenoble Cedex 9
France

© 1996 Hewlett-Packard Company

— User's Guide

Important Safety Information

If you have any doubt that you can lift the PC or display safely, do not try to move it without help.

For your safety, always connect the equipment to a grounded wall outlet. Always use a power cord with a properly grounded plug, such as the one provided with this equipment, or one in compliance with your national regulations. This PC is disconnected from the power by removing the power cord from the power outlet. This means the PC must be located close to a power outlet that is easily accessible.

For your safety, never remove the PC's cover without first removing the power cord from the power outlet, and any connection to a telecommunications network. Always replace the cover on the PC before switching it on again.

Important Ergonomic Information

It is strongly recommended that you read the ergonomic information before using your PC. This information is contained on the CD-ROM that comes with your PC.

Contents

1 Setting Up and Using Your PC

Unpacking Your PC	2
Connecting the Mouse, Keyboard, Display and Printer	3
Connecting Audio Accessories	4
Connecting the Power Cables	5
Starting and Stopping Your PC.....	6
Starting Your PC.....	6
Stopping Your PC.....	6
Setting Passwords	7
Setting an Administrator Password	7
Setting a User Password	8
Using Power Management	9
Additional Information and Help.....	9

2 How to Install Accessories In Your PC

Accessories You Can Install	12
Removing and Replacing the Cover	13
Removing the Cover.....	13
Replacing the Cover after Installing Accessories.....	13
Removing the Air Flow Guide	14

Installing Memory 15

 Main Memory Modules 15

 Upgrading the MGA Millennium Board Memory 17

Installing Mass Storage Devices 19

 Installing an Additional Hard Disk Drive 22

 Installing a Flexible Disk Drive, CD-ROM Drive, or Tape Drive 24

Installing Accessory Boards 26

 Configuring Accessory Boards with Plug and Play 26

 Installing the Board 27

Installing an OverDrive Processor 29

3 Troubleshooting Your PC

Solving Problems 32

HP Summary Screen 32

If Your PC Does Not Start Properly 33

 Display is Blank and There Are No Error Messages 33

 If you are Unable to Change any Values in Setup 34

 If a POST Error Message is Displayed 35

If Your PC Has a Hardware Problem 37

 If Your Keyboard Does Not Work 37

 Display Does Not Work Properly 37

 If Your Mouse Does Not Work 39

 If Your Printer Does Not Work 39

 If the Flexible Disk Drive Does Not Work 40

If the Hard Disk Does Not Work 40

If the CD-ROM Drive Has a Problem. 41

If an Accessory Board Does Not Work 42

If Your PC Has a Software Problem 43

 If You Have Forgotten Your Password 43

 If Your Application Software Does Not Work 44

 If the Date and Time are Incorrect 44

If Your PC Has an Audio Problem 45

Changing the Battery. 47

Technical Information Needed for Troubleshooting. 49

 System Board Switches 49

 Power Consumption. 50

 IRQs, DMAs, and I/O Addresses Used by Your PC 51

The HP Summary Screen and Setup Program 52

 HP Summary Screen 52

 Using the HP Setup Program. 53

4 Hewlett Packard Support and Information Services

Your HP Authorized Reseller 58

HP SupportPack. 58

HP Support Assistant CD-ROM 58

Hewlett-Packard Information Services. 59

 HP Forum on CompuServe 59

HP Forum on America Online	60
HP BBS Library	61
Internet—FTP Library Service	61
Access HP World Wide Web Site	61
HP FAXback on Demand—HP FIRST	62
HP Audio Tips (USA only) HP Automated Support Directory	62
Ordering Drivers and BIOS on Diskette	63
HP Support Services	64
Hewlett-Packard Telephone Support	65
Lifeline Telephone Support (U.S. Only)	65
HP Network Phone-in Support Service (NPS)	66
Hewlett-Packard Marketing Headquarters	66
Glossary	67
Index	69

1

Setting Up and Using Your PC

1 Setting Up and Using Your PC

Unpacking Your PC

Unpacking Your PC

- 1 When you receive your PC, unpack all the components.

WARNING

If you have any doubt that you can lift the PC or display safely, do not try to move it without help.

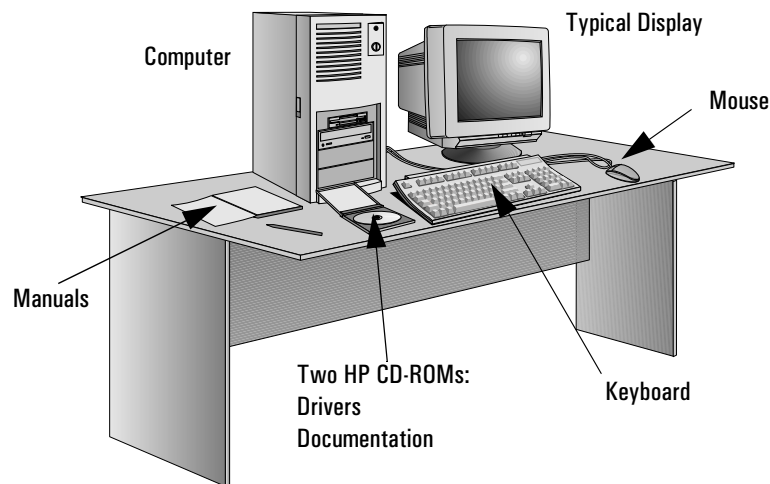

- 2 Place the PC on a sturdy desk near to easily accessible power outlets, with enough space for the keyboard, mouse, and any other accessories.
- 3 Position the PC so that its rear connectors are easily accessible. (You can place the PC on the floor instead of on the table, if desired.)
- 4 Refer to the display's manual for information about the display.

Operating System

Your PC's operating system is packed separately inside the box that contains your PC.

Installation Tools

No tools are required to set up your PC. However, if you plan to install a disk drive or an accessory board in your PC, you will need a flat-blade screwdriver. For further information about installing accessories, refer to chapter 3, "How to Install Accessories In Your PC".

Connecting the Mouse, Keyboard, Display and Printer

Connect the mouse, keyboard, and display to the back of the computer. *The connectors are shaped to go in one way only.* Tighten the display cable attachment screws.

Connect the printer cable to the back of the computer and tighten the attachment screws. Use the connector labeled:

- Parallel (25-pin parallel connector) for a parallel device
- Serial A (9-pin serial connector) for a serial device
- Serial B (9-pin serial connector) for a second serial device.

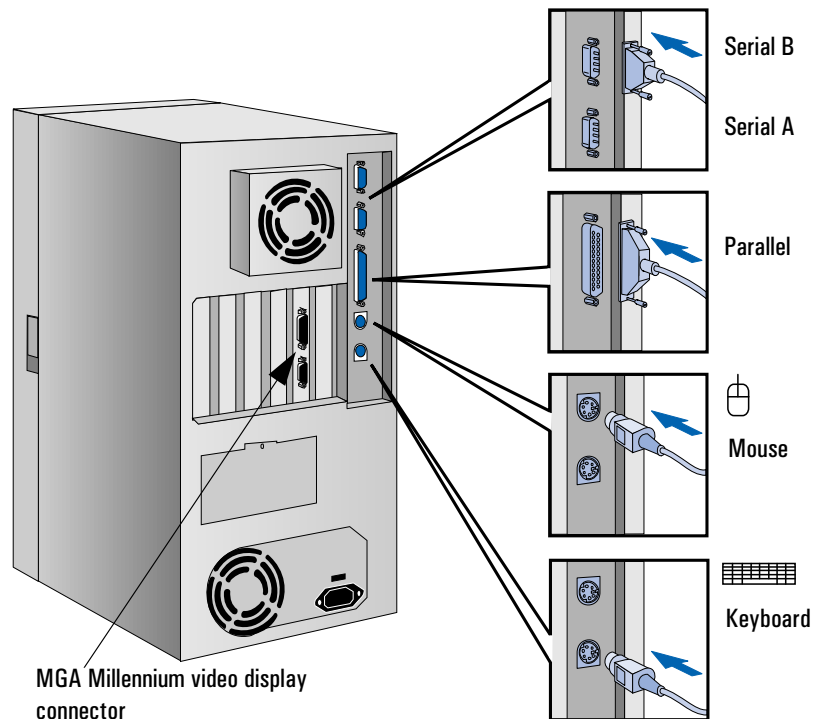

1 Setting Up and Using Your PC

Connecting Audio Accessories

Connecting Audio Accessories

Your PC has a Headphones jack and a Microphone jack on the rear panel. An audio Stereo In jack, an audio Stereo Out jack, and a MIDI interface connector are also located on the rear panel.

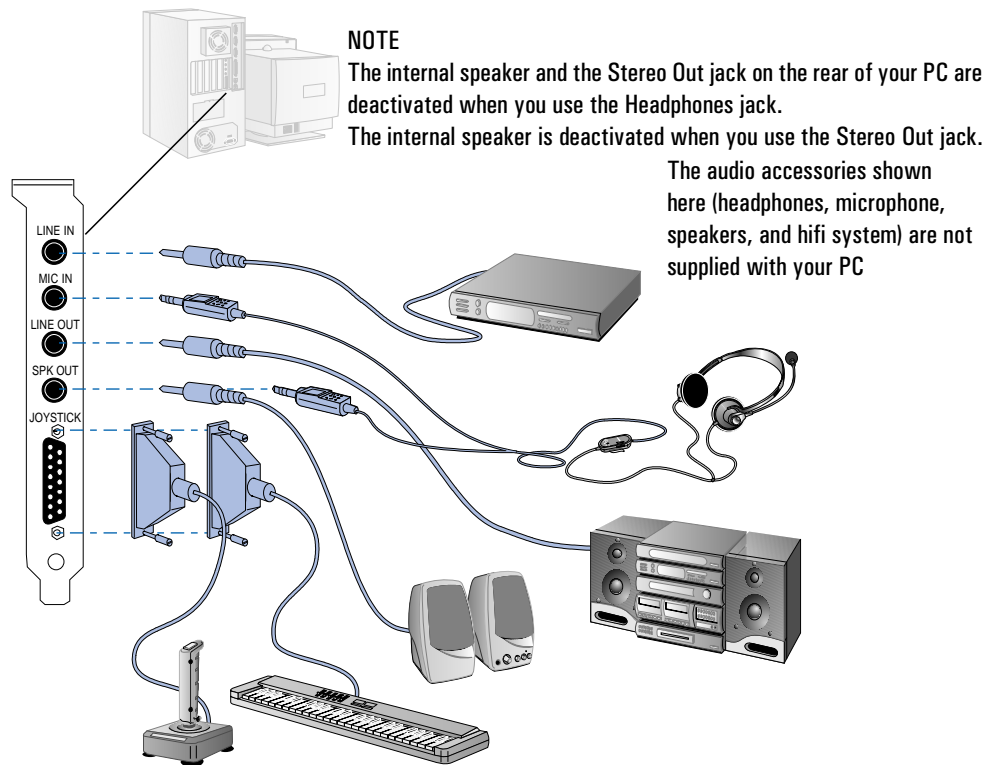

WARNING

To avoid discomfort from unexpected noise, always turn the volume down before connecting headphones or speakers.

Listening to loud sounds for prolonged periods may permanently damage your hearing.

Before putting on headphones, place them around your neck and turn the volume down. When you put on the headphones, slowly increase the volume until you find a comfortable listening level, and leave the volume control in that position.

Connecting the Power Cables

- 1 Remove the warning label covering the computer's power connector at the rear of the computer.
- 2 Check that the correct voltage is selected for your country. (The voltage is set during manufacture, and should be already correct.)

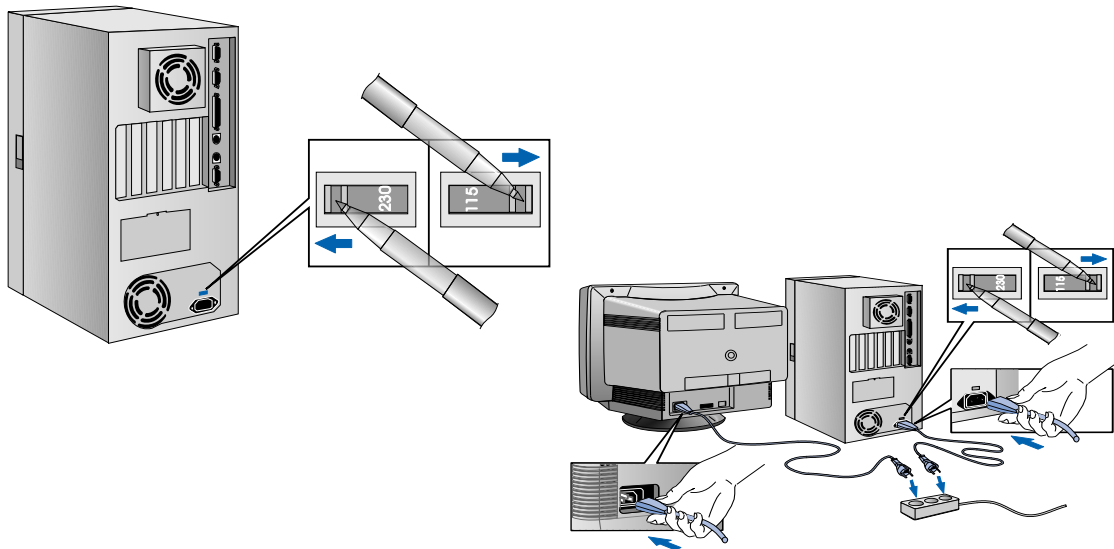

- 3 Connect the power cables to the display and the computer. (The connectors are shaped to go in one way only.)
- 4 Connect the display's power cable and the computer's power cable to grounded outlets.

WARNING

For your safety, always connect the equipment to a grounded wall outlet. Always use a power cable with a properly grounded plug such as the one provided with this equipment or in compliance with your national regulations. This PC is disconnected from the power by removing the power cable from the power outlet. This means the PC must be located close to a power outlet that is easily accessible. This PC is as class 1 laser product.

1 Setting Up and Using Your PC

Starting and Stopping Your PC

Starting and Stopping Your PC

Starting Your PC

- 1 Before you start your PC, always switch on the display first.
- 2 Start your PC in one of these ways:
 - press the power button on the front panel
 - press the space bar.

When you switch on the computer, the computer carries out the Power-On-Self-Test (POST) while the Vectra logo is displayed. If you wish to view the POST details, press **[Esc]** to get the HP Summary Screen. If there is an error in the POST, the error will automatically be displayed.

- 3 If you have set a password in the PC's *Setup* program, the password prompt displays after the POST has completed. If the Password prompt is displayed, type your password and press **[Enter]** to be able to use the PC.

Stopping Your PC

To stop the PC, make sure that you have exited all programs and the operating system (if necessary), and then press the power button on the control panel.

Refer to the operating system manual for details of how to exit the operating system.

Setting Passwords

You can set two passwords, the administrator password and the user password, to provide two levels of protection for your PC. You set both passwords in the Security menu group of the *Setup* program.

Setting an Administrator Password

Set the Administrator Password to protect the PC's configuration in *Setup*. An Administrator Password can provide a power-on password prompt to prevent your PC being started or used in your absence. You can also use this password to start the PC when the keyboard (and mouse) are locked—you must type the password and press  to unlock the keyboard (refer to "Power-On Password" in the Administrator Password Submenu of the Security Menu in the HP *Setup* program).

If you have set both an Administrator Password and a User Password, and you enter the *Setup* program by using the User Password, you will be restricted in your ability to change setup items. If you enter the *Setup* program with an Administrator Password, you will have no restrictions.

To set an Administrator Password:

- 1 Start the Setup Program. Refer to "Using the HP Setup Program", on page 53.
- 2 Select the Security menu group.
- 3 Select the "Administrator Password" submenu.
- 4 Choose the "Set Administrator Password" setup item. You will be asked to enter your password twice. Be sure to save your changes before you exit the *Setup* program.

To remove the password, follow the same procedure as to set a password, but do not enter anything in the password field. Press return and then press return a second time to confirm your action.

NOTE

If you forget your password, refer to "If You Have Forgotten Your Password", on page 43.

1 Setting Up and Using Your PC

Setting Passwords

Setting a User Password

A user password can only be set if an Administrator Password has already been set.

Set a User Password to:

- provide a power-on password prompt to prevent your PC from being started or used in your absence
- start the PC when the keyboard (and mouse) are locked—you must type the password and press  to unlock the keyboard (refer to “Power-On Password” in the Administrator Password Submenu of the Security Menu in the HP *Setup* program).

If you have set both an Administrator Password and a User Password, and you enter the *Setup* program by using the User Password, you will only be able to change Main setup items. If you enter the *Setup* program with an Administrator Password, you will have no restrictions.

To set a User Password:

- 1 Start the Setup Program. Refer to "Using the HP Setup Program", on page 53.
- 2 Select the Security menu group.
- 3 Select the “User Password” submenu.
- 4 Choose the “Set User Password” setup item. You will be asked to enter your password twice. Be sure to save your changes before you exit the *Setup* program.

To remove the password, follow the same procedure as to set a password, but do not enter anything in the password field. Press return and then press return a second time to confirm your action.

NOTE

If you forget your password, refer to "If You Have Forgotten Your Password", on page 43.

Using Power Management

Power management enables you to reduce the PC's power consumption when you are not using the PC. To configure power management, to refer to the Power Menu in the HP *Setup* program.

Refer to your operating system documentation for detailed information about the capabilities of your operating system to implement power management.

Additional Information and Help

Additional information about your PC is supplied on a documentation CD-ROM that comes with your PC. It includes:

- New features—what is new and special about your PC
- Using your PC—simple, “how-to-use” guidelines about using your PC
- Working in comfort—guidance on ergonomic issues
- Inside your PC—describes the basic parts of your PC, how to upgrade, and how to optimize performance
- HP support—similar to chapter 4 in this User's Guide.

1 Setting Up and Using Your PC
Additional Information and Help

2

How to Install Accessories In Your PC

This chapter explains how to install accessories, such as extra memory, accessory boards, and additional disk drives, in your PC.

2 How to Install Accessories In Your PC

Accessories You Can Install

Accessories You Can Install

Please contact your authorized reseller for information about HP accessory part numbers.

WARNING

For your safety, never remove the PC's cover without first removing the power cord from the power outlet, and any connection to a telecommunications network. Always replace the cover on the PC before switching it on again.

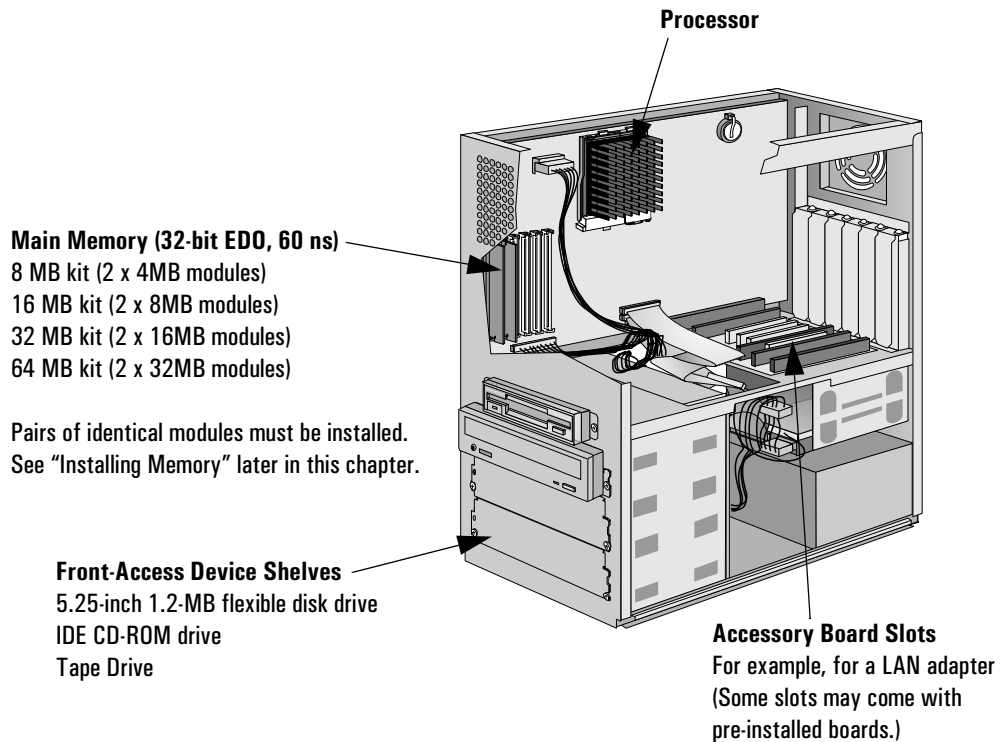

Removing and Replacing the Cover

Removing the Cover

- 1 Switch off the display and computer.
- 2 Disconnect all power cables and any telecommunications cables.
- 3 If necessary, unlock the cover using the key on the front panel.
- 4 Lift the two latches on the front sides of the computer upwards. Slide the cover forwards and off the computer.

Replacing the Cover after Installing Accessories

- 1 Ensure that you have installed all your accessories and that all internal cables are properly connected and safely routed.
- 2 Ensure that the two latches on the front sides of the cover are upwards, and that the lock is unlocked.
- 3 Slide the cover onto the computer, making sure that the two guides at the bottom of the case slide into the two rails at the base of the computer. Firmly slide the cover backwards into position.
- 4 Lower the two latches on the front sides of the cover.
- 5 If required, lock the cover using the key provided.
- 6 Reconnect all the power cables.

2 How to Install Accessories In Your PC

Removing the Air Flow Guide

Removing the Air Flow Guide

Your PC has an air flow guide to help reduce the heat of the processor. You must remove this guide before you can access the processor, the system board switches, the battery, or any accessory board.

To remove the air flow guide, unclip it from the side of the PC after you have removed the cover.

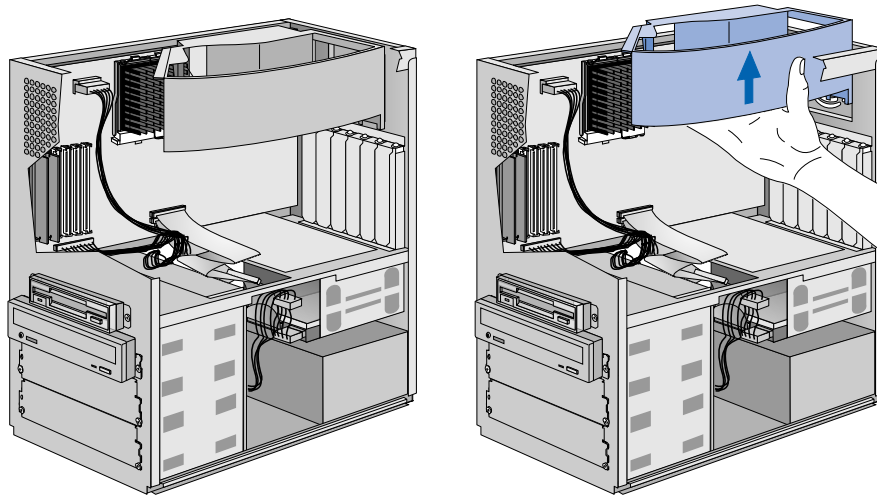

NOTE:

The air flow guide on your PC may be different from the one shown in this illustration.

Installing Memory

CAUTION

Static electricity can damage electronic components. Turn all equipment OFF. Don't let your clothes touch the accessory. To equalize the static electricity, rest the accessory bag on top of the PC while you are removing the accessory from the bag. Handle the accessory as little as possible and with care.

Main Memory Modules

Your PC is supplied with main memory. If you need more main memory to run your application software, you can install up to a total of 192 MB (6 x 32 MB).

Main memory is available in modules of 4 MB, 8 MB, 16 MB, or 32 MB. There are three memory "banks", with each bank requiring two memory modules. You must install identical modules as pairs in each bank.

Bank	Memory Modules You can Install
A1 and A2	Comes preloaded with either 16 MB (2 x 8 MB) or 32 MB (2 x 16 MB).
B1 and B2	Any pair of identical modules.
C1 and C2	Any pair of identical modules.

To install a main memory module:

- 1 Disconnect the computer's power supply cord and any connection to a telecommunications network.
- 2 Remove the computer's cover.

2 How to Install Accessories In Your PC

Installing Memory

- 3 Align the memory module with the slot, with the notch on the right hand side. For each memory module, slide it into the slot at 45°. Pivot the memory module to a perpendicular position and click into place.

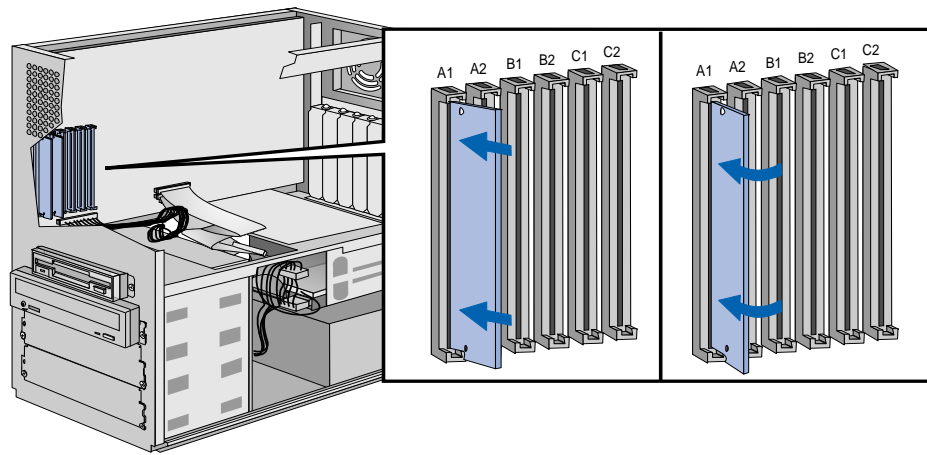

- 4 If you need to remove a main memory module, release the retaining clip and pull the module forward and out of the socket.
- 5 Install any other accessories before replacing the cover. Reconnect all cables and power cords.
- 6 Check the HP Summary Screen to verify the new configuration. Refer to "HP Summary Screen", on page 52.

Upgrading the MGA Millennium Board Memory

- 1 Switch off the display and computer, and disconnect the power supply cables and any telecommunications cables. Remove the computer's cover.
- 2 Unscrew and remove the screw securing the MGA Millennium board. Put the screw to one side. Note which slot the board is in.
- 3 Carefully remove the board from its slot, holding the board at each end by its top edge. Do not bend the board. With its components facing up, place the board on a clean, flat, solid, static-free surface. Handle the board by its edges.
- 4 Install the memory module on the video board. Carefully slide the board back into its slot. Firmly press the board into the socket. Make sure that the board's connector engages completely with the socket and does not touch components on other boards you may have installed. Secure the board by replacing the screw.

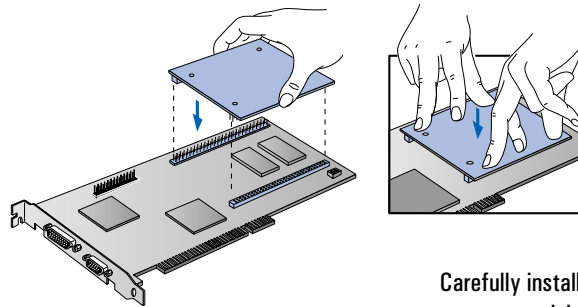

Carefully install the video memory module

2 How to Install Accessories In Your PC

Installing Memory

- 5 Install any other accessories before replacing the cover and reconnecting the cables.
- 6 After switching on the PC, change the video resolution and the number of colors displayed. Alternatively, use utilities supplied with the operating system. See your operating system documentation and online help for more information.

Configuration Switches Two configuration switches are on the Matrox video adapter board.

Switch	Use Switch Block to:
1	Flash EEPROM Switch for VGA BIOS: <ul style="list-style-type: none">• OFF to prevent Video BIOS upgrades — DEFAULT• ON to allow Video BIOS upgrades.
2	Enable or disable VGA for single-screen or dual-screen operation (with a second VGA controller): <ul style="list-style-type: none">• OFF for single-screen operation — DEFAULT• ON for dual-screen operation (with a second VGA controller).

Contact your HP representative for further information about upgrading the VGA BIOS.

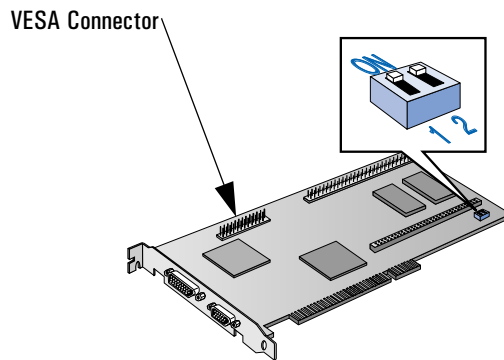

Installing Mass Storage Devices

If you need to have extra mass storage space for your application software, you can install additional mass storage devices, such as a flexible disk drive, hard disk drive, or tape drive.

Your PC already has one hard disk drive installed in the back shelf. You can install another hard disk drive in the bottom internal shelf, beneath the existing hard disk drive.

Your PC has a 3.5-inch flexible disk drive and a CD-ROM drive installed in two front-access device shelves. Two more front-access device shelves are available to install flexible disk drives, CD-ROM drives, or tape drives.

Your PC has the following cables and connectors on the system board which may be used by mass storage devices:

- An Enhanced IDE (Integrated Drive Electronics) hard disk drive cable. This supports up to two IDE hard disk drives, one of which is already connected. On the system board, this cable's connector is labeled "Primary IDE".
- A second Enhanced IDE drive cable with two connectors. If you install a CD-ROM drive, or a third hard disk drive, or both, connect it or them to this cable. On the system board, this cable's connector is labeled "Secondary IDE".
- A flexible disk drive cable. This supports up to two flexible disk drives, one of which is already connected.

NOTE

You can install a non-IDE mass storage device, but this requires an accessory board and driver software. Contact your authorized reseller for information.

2 How to Install Accessories In Your PC

Installing Mass Storage Devices

Internal Connectors

If you add a flexible disk drive, hard disk drive, CD-ROM drive, or tape drive, you need to connect it to power and data cables. The data cables are shown below:

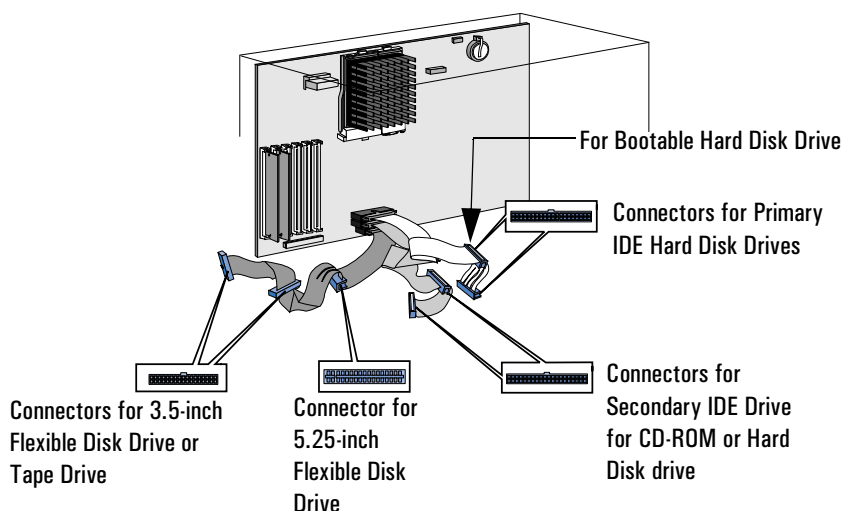

Which Connectors to Use

There are two different cables for IDE drives:

- The first cable is attached to the connector marked “Primary IDE” on the system board connector, and has two connectors on the cable. The first connector must be connected to the bootable (master) hard disk drive. The second (or slave) connector is for a secondary hard disk drive.
- The second cable is attached to the connector marked “Secondary IDE” on the system board, and has two connectors on the cable. The connectors can be used for either CD-ROM drives or hard disk drives.

NOTE

If you install a hard disk drive and connect it to the same cable to which the CD-ROM drive is connected, the hard disk drive must be connected to the *middle* connector, not the end connector. If you have a CD-ROM drive currently connected to the middle connector, you must reconnect the CD-ROM drive to the end connector of the cable, and then attach the new hard disk drive to the middle connector.

2 How to Install Accessories In Your PC
Installing Mass Storage Devices

The following table explains which connectors you should use when you install additional devices.

Configuration	Connections to Data Cables	
1 Hard Disk Drive	1. Bootable hard disk drive:	First connector, Primary IDE Cable
2 Hard Disk Drives	1. Bootable hard disk drive: 2. Second hard disk drive:	First connector, Primary IDE Cable Second connector, Primary IDE Cable
3 Hard Disk Drives	1. Bootable hard disk drive: 2. Second hard disk drive: 3. Third hard disk drive:	First connector, Primary IDE Cable Second connector, Primary IDE Cable Secondary IDE Drive Cable Connector
4 Hard Disk Drives	1. Bootable hard disk drive: 2. Second hard disk drive: 3. Third hard disk drive: 4. Fourth hard disk drive:	First connector, Primary IDE Cable Second connector, Primary IDE CableCD- Secondary IDE Drive Cable Connector Secondary IDE Drive Cable Connector

NOTE

When connecting hard disk drives, note that if the drives are connected to the same data cable, and the drives operate in different modes (or speeds), the slower speed will be used. To avoid possible degradation of disk performance, it is recommended that, whenever possible, hard disk drives are placed on different cables.

There are two different types of connectors—these are shown below.

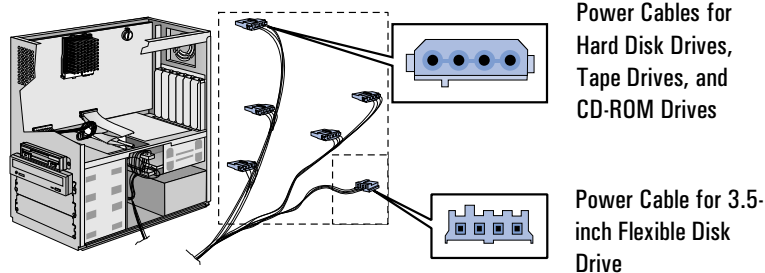

Some of the power connectors will already be connected to devices. If you install a device that requires a different connector, the connector converter should be supplied with the device.

2 How to Install Accessories In Your PC

Installing Mass Storage Devices

Installing an Additional Hard Disk Drive

Refer to the drive's manuals to see if you must set jumpers or if there is a special installation procedure to follow. If your new hard disk drive already has a mounting tray attached, you must remove it before you can install the drive in your PC.

CAUTION

Make sure that you back up your files before you install a hard disk drive. Refer to your operating system documentation for information on how to do this.

- 1 Switch off the display and computer, and disconnect the power supply cables and any telecommunications cables.
- 2 Remove the computer's cover (see page 13).
- 3 Unscrew the access plate on the rear on the computer.
- 4 Pass the drive through the shelf.
- 5 Secure the drive to the box, using the four screws provided with the drive. Two screws must be inserted in each side. Using screws other than those provided may cause damage to the device.

Step 3: Unscrew rear access plate.

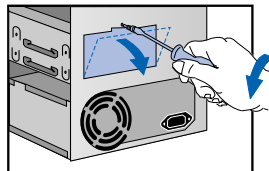

Step 4: Pass drive through shelf.

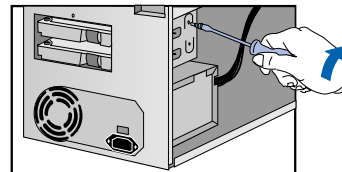
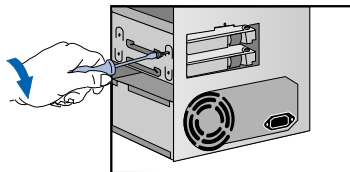
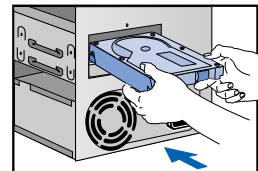

Step 5: Secure drive to box.

2 How to Install Accessories In Your PC

Installing Mass Storage Devices

- 6 Resecure the access plate on the rear of the computer.
- 7 Connect the power and data cables to the rear of the drive, if you have not done so already. The connectors are shaped to fit one way only. Use the end connector on the diskette data cable—see “Internal Connectors” on page 20 for an illustration of the cables and connectors.

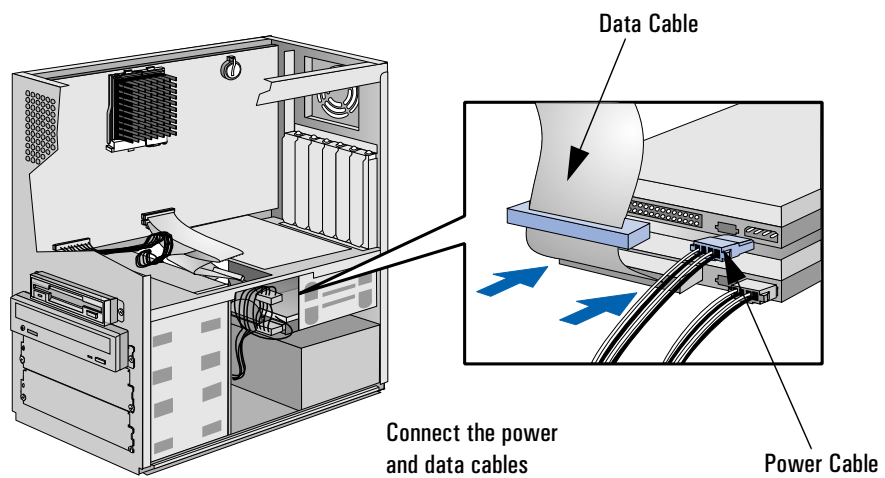

- 8 Install any other accessories, before replacing the cover.

2 How to Install Accessories In Your PC

Installing Mass Storage Devices

Installing a Flexible Disk Drive, CD-ROM Drive, or Tape Drive

WARNING

To take care to avoid electric shock and harm to your eyes by laser light from a CD-ROM drive, do not open the CD-ROM drive enclosure. The drive should be serviced by authorized service personnel only.

- 1 Switch off the display and computer, and disconnect the power supply cables and any telecommunications cables.
- 2 Remove the computer's cover (see page 13).
- 3 If present, remove the small cover plate on the shelf by removing the two screws and pulling it out.
- 4 Check that the mounting rails are attached to the device with the screws provided.
- 5 Slide the drive completely into the shelf.
- 6 Connect the power and data cables to the rear of the device (the connectors are shaped to go in one way only). See "Internal Connectors" on page 20 for more information about which connectors to use.
- 7 Secure the device in position using the screws provided with the device.
- 8 To allow access to the device, remove the relevant shelf cover plate from the cover by pulling the plate from the left and unhinging its right-hand side. Store it in a safe place.
- 9 Install any other accessories before replacing the cover.

2 How to Install Accessories In Your PC

Installing Mass Storage Devices

To Install a Drive:

Step 3: Remove the cover plate (if present).

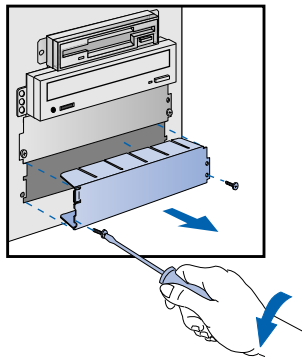

Step 5: Slide the drive into the shelf.

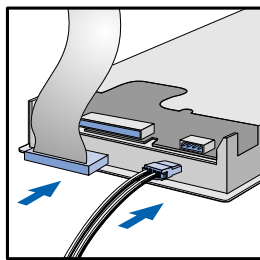
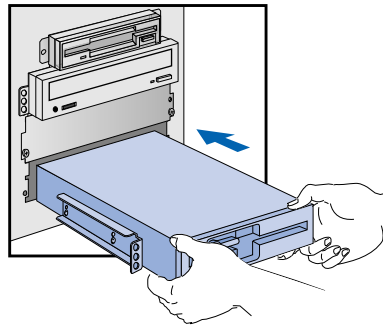

Step 6: Connect the power and data cables.

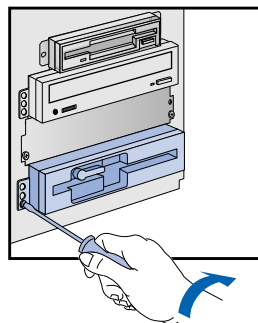

Step 7: Secure the device in position.

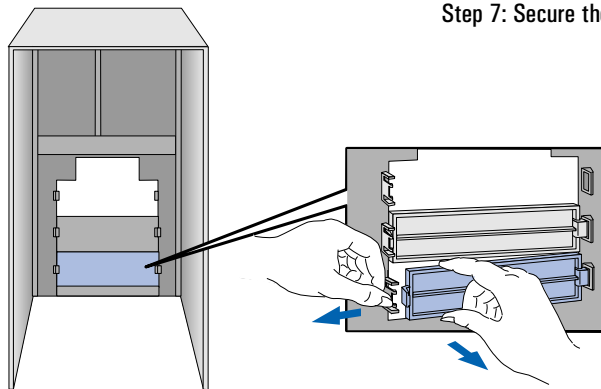

Step 8: Remove the shelf cover plate

2 How to Install Accessories In Your PC

Installing Accessory Boards

Installing Accessory Boards

The PC has six accessory board slots with seven connector sockets. These slots allow you to install upgrade boards as follows:

- Slot 1 (innermost) can be used for a 16-bit ISA or a 32-bit PCI board (26cm/10.2-inch maximum length)
- Slots 2 and 3 can be used for 32-bit PCI boards
- Slot 4 can be used for a full-length 16-bit ISA or a 32-bit PCI board
- Slots 5 and 6 can be used for full-length 16-bit ISA boards.

CAUTION

Static electricity can damage electronic components. Turn all equipment off. Don't let your clothes touch the accessory.

To equalize the static electricity, rest the accessory bag on top of the computer while you are removing the accessory from the bag. Handle the accessory as little as possible and with care.

Configuring Accessory Boards with Plug and Play

Plug and Play is an industry standard for automatically configuring your PC's hardware resources and the accessory boards installed in it. If your operating system supports Plug and Play, your PC has configurable support for Plug and Play in the BIOS.

All PCI accessory boards are Plug and Play, although not all ISA boards are. Check the accessory board's documentation if you are unsure.

When you start your PC after installing an accessory board, the Plug and Play BIOS automatically detects which hardware resources (IRQs, DMAs, memory ranges, and I/O addresses) are used by the system-based components.

Configuring non-Plug and Play ISA Accessory Boards

If you install an ISA accessory board that is not Plug and Play you will need to configure the board before your PC can use it.

Refer to the documentation supplied with the operating system for details on your operating system's capabilities and restrictions concerning how to configure non-Plug and Play accessory boards.

2 How to Install Accessories In Your PC

Installing Accessory Boards

Installing the Board

- 1 Switch off the display and computer, and disconnect the power supply cables and any telecommunications cables. Remove the computer's cover.
- 2 Remove the air flow guide (refer to "Removing the Air Flow Guide", on page 14).
- 3 Find a free accessory board slot with the correct type of connector socket (PCI or ISA). Some boards may have preferred locations, in which case special installation instructions should be detailed in their manuals.
- 4 Unscrew and remove the accessory board slot cover. Store it in a safe place. If the slot cover is tight, loosen the screws on the adjacent slots.

Step 4: Unscrew and remove the accessory board slot cover.

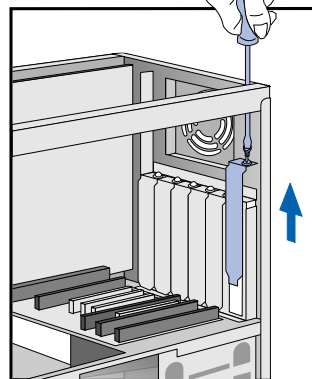

Step 5: Slide the board into a free slot.

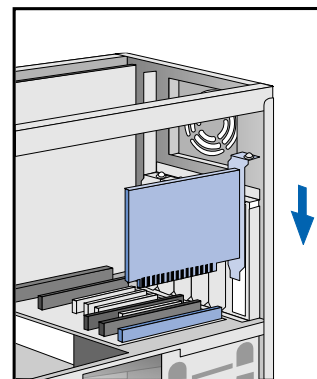

- 5 Hold the board vertically with the connector towards the socket. Slide it into the free slot from which you have just removed the slot cover. Do not bend the board.

2 How to Install Accessories In Your PC

Installing Accessory Boards

- 6 Align the board's connector with the slot's socket. Firmly press the board into the socket. Ensure that the board's connector engages completely with the socket and does not touch components on other boards. The connector is fully in the socket when the board is aligned with the other slot covers.
- 7 Secure the board by replacing the slot cover screw.
If you loosened the screws on adjacent slots, tighten them.
- 8 If you have installed a VESA-standard video adapter board, connect the accessory board's cable to the VESA pass-through connector on the Matrox MGA Millennium video board.

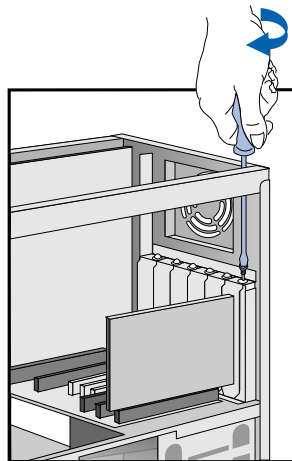

Step 7: Secure the board.

- 9 Install any other accessories before replacing the cover and reconnecting the cables.

Installing an OverDrive Processor

You can install an Intel OverDrive™ processor in your PC. Contact your authorized reseller for more details about the availability of the Intel OverDrive processor for your PC.

- 1 Disconnect the computer power cords from the power outlets, and disconnect the PC from any telecommunications network.
- 2 Remove the computer's cover.
- 3 Remove the air flow guide (refer to "Removing the Air Flow Guide", on page 14).
- 4 If the heatsink is not directly attached to the processor, unclip and remove the heatsink. (Be careful not to let the heatsink fall when you unclip it.)
- 5 Raise the lever on the socket to unlock the processor and lift out the processor. (Be sure not to let the processor fall when you unlock and lift it out.)

2 How to Install Accessories In Your PC

Installing an OverDrive Processor

- 6 To install the new processor:
 - a Locate the corner markers:
 - on the processor—a dot or notch (“broken” corner)
 - on the processor socket—a dot.
 - b Position the processor over the socket, with it’s corner marker facing the corner marker on the socket.
 - c Place the processor into the socket.
 - d Lower the lever to lock the processor into place.
 - e Replace the heatsink and fasten the clip, if the heatsink is not directly attached to the processor.

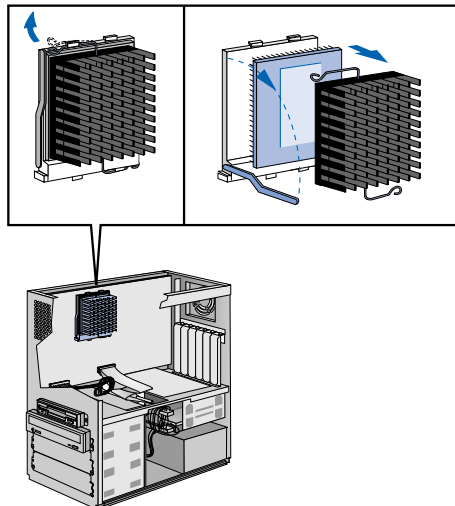

CAUTION

Do not change the system board switches after you install an OverDrive processor processor.

- 7 Replace the PC’s cover. Reconnect all cables and power cords.

3

Troubleshooting Your PC

This chapter can help you solve problems that you may encounter when using your PC. It also introduces the HP Summary Screen and the HP *Setup* Program.

3 Troubleshooting Your PC

Solving Problems

Solving Problems

This chapter can help you solve most problems you might have with your PC.

If you are unable to solve your problem after following the advice in this chapter, refer to "Hewlett Packard Support and Information Services", on page 57.

HP Summary Screen

The HP Summary Screen provides information about your PC's current configuration. To view the Summary Screen, press **Esc** just after your PC is switched on and while the Vectra Logo appears during the Power-on-Self-Test (POST). Refer also to "HP Summary Screen", on page 52.

If Your PC Does Not Start Properly

Use this section if your PC does not start properly when you turn it on, and you experience one of the following symptoms:

- Your PC's display is blank and there are no error messages.
- You cannot change any values in the *Setup* program.
- A POST error message is displayed.

Display is Blank and There Are No Error Messages

If your display is blank and there are no error messages when you turn on your PC, follow this procedure:

- 1 Check external items.
- 2 Check internal items.
- 3 Rebuild your PC's components.

Check External Items

Be sure the following external items are functioning properly:

- Check that the computer and display are turned on. (The power light should be illuminated.)
- Check the display's contrast and brightness settings.
- Make sure that all cables and power cords are firmly plugged in.
- Make sure the power outlet is working.

3 Troubleshooting Your PC

If Your PC Does Not Start Properly

Check Internal Items If the PC still does not start properly, follow this procedure to check the internal items:

- 1 Turn off the display, the computer, and all external devices.
- 2 Unplug all power cords and cables, noting their positions. Disconnect the PC from any telecommunications network.
- 3 Remove the cover.
- 4 Check the following items:

Action	Reference
Check all internal cables.	Ensure they are correctly attached and firmly in place.
Check that the processor is correctly installed.	Refer to "Installing an OverDrive Processor" on page 29.
Check that the processor speed switches have been set correctly.	Refer to "System Board Switches" on page 49.
Check that the memory modules are correctly installed.	Refer to "Installing Memory" on page 15.
Check that accessory boards are firmly seated in their slots.	Refer to "Installing Accessory Boards" on page 26.
Verify that any switches and jumpers on the accessory boards are properly set.	Refer to the manuals that came with each board.
Check that the switches on the system board are properly set.	Refer to "System Board Switches" on page 49.

- 5 Replace the cover.
- 6 Reconnect all cables and power cords.
- 7 Turn on the display and computer.

Rebuild Your PC's Components

If your PC still does not start properly, remove all boards and accessories, except the hard disk drive. Start the PC. If the PC now works, add the boards and accessories one at a time to determine which one is causing the problem.

If you are Unable to Change any Values in *Setup*

If the Secure Switch on the system board is set to "closed", you cannot change any of the values in *Setup*.

- 1 Turn off the display, the computer, and all external devices.
- 2 Unplug all power cords and cables, noting their positions. Disconnect the PC from any telecommunications network.
- 3 Remove the cover.
- 4 Check the system board switches. Refer to "System Board Switches", on page 49. Be sure the Secure Switch is set to "open".
- 5 Replace the cover.
- 6 Reconnect all cables and power cords.
- 7 Turn on the display and computer.

If a POST Error Message is Displayed

The Power-On-System-Test (POST) can detect both an error and a change to the configuration. In either case, an error code and short description is displayed. Depending on the kind of error, you will have one or more of these choices available on screen:

- Press **(F1)** to ignore the message and continue.
- Press **(F2)** to run *Setup* and correct a system configuration *error*. HP recommends that you correct the error before proceeding, even if the PC appears to start successfully.
- Press **(F4)** to accept (validate) the change and update *Setup's* configuration information.
- Press **(Enter)** to see more details about the message. After viewing these details, you will be returned to the original POST display screen. If the message is actually a change to the configuration you have made (for example, you have just removed some memory), you can then press **(F4)** to accept the change and update *Setup's* configuration information. Otherwise, press **(F1)** to ignore the message and continue, or press **(F2)** to run *Setup* and correct a system configuration *error*. (The number of choices you will have available are dependent on the kind of error.)

3 Troubleshooting Your PC

If Your PC Does Not Start Properly

Clearing the PC's Configuration Memory

If the PC then starts, but POST still persists in reporting an error, clear the current configuration memory values and reinstall the built-in default values:

- 1 Turn off the PC, disconnect the power and cables, and remove the cover. Disconnect the PC from any telecommunications network.
 - a Set the system board switch 6 (CMOS STATUS) to CLOSED to clear the configuration.
 - b Replace the cover, and reconnect the power cable only.
 - c Turn on the PC. This will erase the CMOS memory.
 - d Wait until the PC has started. A message will be displayed similar to this:
"Configuration has been cleared, set switch 6 to the OPEN position before rebooting."

Turn off the PC, disconnect the power cable, and remove the cover.
 - e Set the system board switch 6 (CMOS STATUS) on the switch block to OPEN to re-enable the configuration.
- 2 Replace the cover, and reconnect the power and cables.
- 3 Switch on the PC. An error message will be displayed similar to this:
"Incorrect PC configuration"
The PC will stop. Press any key to continue. A "pop-up" screen will appear stating that the:
"CMOS checksum is invalid.
Default values will be loaded.
Press any key to continue".
- 4 Run *Setup* by pressing **(F2)**. CMOS default values will be automatically downloaded and saved.
- 5 Make any other changes you want and press **(F3)** to save the configuration and exit from *Setup*.

If Your PC Has a Hardware Problem

This section describes what to do if you have problems with your keyboard, display, disk drives, printer, accessory board, or mouse.

If Your Keyboard Does Not Work

- Ensure that the keyboard is correctly connected.
- If you turn on your PC, the operating system boots, the keyboard is correctly connected, but your keyboard is still not available, the power-on password may be set to “keyboard locked”. You will need to enter a password to unlock the keyboard (and mouse). You can change this setting in the *Setup* program. Refer to the Power Menu in the HP *Setup* program.

Display Does Not Work Properly

If Your Display is Blurred or Unreadable

If you have selected the wrong display, the display screen may become blurred or unreadable. To correct this problem:

- Select the correct display by referring to the display options section in the HP-provided online user setup information that came with your PC.
- Alternatively, select the correct display by using the procedures in the operating system on your PC. Refer to your PC’s operating system documentation for details.

3 Troubleshooting Your PC

If Your PC Has a Hardware Problem

If Nothing is Displayed on the Screen

If nothing is displayed on the screen, but the PC starts and the keyboard, disk drives, and other peripheral devices seem to operate properly:

- Make sure that the display is plugged in and switched ON.
- Check that the brightness and contrast controls are properly set.
- Ensure that the display video cable is correctly connected.
- Switch off the display, and unplug it from the power outlet. Disconnect the video cable and examine the video cable connector pins. If the pins are bent, carefully straighten them.
- Check that the video upgrade is properly installed if you have one.
- Check that an accessory board doesn't use the same I/O address as the integrated video interface (03B0h to 03DFh). Refer to the manual supplied with the accessory for further information.
- If the display works correctly during the Power-On-Self-Test (POST), but goes blank when Windows starts, check that you have enough memory for the video mode you have selected.
- If your screen's refresh rate is set too high, the screen might be blank. Check the refresh settings to ensure they are not too high.

Other Display Problems

If the display image is not aligned with the screen, use the display's controls to center the image (refer to the display manual for instructions). If the screens generated by the applications do not appear to be correct, check the application's manual to find out which video standard is required. Also check your display manual to find out which refresh rate is required. Use *Setup*, or your operating system's procedures, to select the correct refresh rate

If Your Mouse Does Not Work

- Ensure that the mouse is correctly connected.
- Ensure that the mouse driver supplied with the preloaded software is installed correctly. (Choose a Logitech® mouse driver.)
- Clean the mouse ball and rollers as shown in the figure below (use a non-residual contact cleaner).

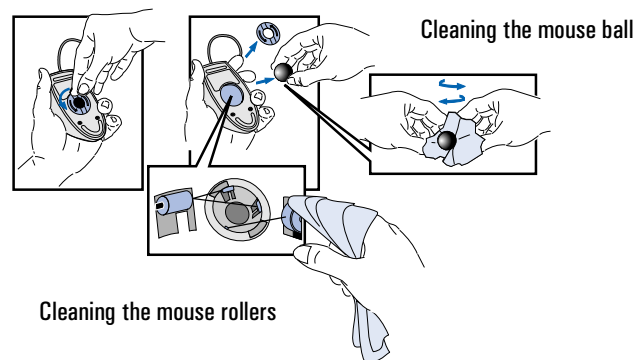

If Your Printer Does Not Work

- Make sure the printer's power switch is ON.
- Verify that the power cord is plugged into the power outlet and the printer.
- Verify that you have the correct cable for the printer. Make sure that it is securely connected to the correct connector (port) on the PC and printer.
- Check that the printer is online.
- Examine the paper feed mechanism for a paper jam.
- Make sure that the printer is configured correctly for the PC and for the application.
 - a Ensure the PC's port has been correctly configured using *Setup*.
 - b Make sure the printer is correctly set up in your operating system's configuration.
 - c Ensure the application program's "print" menu has been correctly set up. (Refer to the manual supplied with the application software.)
- Check that the PC's port is working properly by running another peripheral connected to the port.
- If you receive an error message, refer to the printer's manual for help.

3 Troubleshooting Your PC

If Your PC Has a Hardware Problem

If the Flexible Disk Drive Does Not Work

- Ensure you are using a formatted diskette and it is inserted correctly.
- Check you are using a diskette that is the right density.
- Check that your flexible disk drive is correctly configured in the *Setup Configuration* menu.
- Check the option on the *Setup Configuration* menu which enables or disables the on-board flexible disk controller.
- Clean the flexible disk drive using a diskette cleaning kit.
- Check that the flexible disk drive has been enabled in *Setup*.
 - Flexible disk drive (refer to the Hardware Protection Submenu of the Security Menu in the *Setup* Program)
 - Boot on flexible disk drive (refer to the Start-up Center Submenu of the Security Menu in the *Setup* Program)
 - Write on flexible disk drives (refer to the Start-up Center Submenu of the Security Menu in the *Setup* Program).
- Check that the disk power and data cables are correctly connected.

If the Hard Disk Does Not Work

- Check that the disk power and data cables are correctly connected (refer to "Internal Connectors", on page 20).
- Check that the hard disk drive has been "enabled" (refer to the Hardware Protection Submenu of the Security Menu in the *Setup* Program). There is also an option in the *Setup* program that lets you disable or enable boot on hard disk drive (refer to the Start-up Center Submenu of the Security Menu in the *Setup* Program).
- Check that the hard disk drive has been detected (refer to the IDE Devices Submenu of the Configuration Menu in the *Setup* Program).
- Check that the on-board Bus IDE is enabled if you are using the integrated IDE controller (refer to the IDE Devices Submenu of the Configuration Menu in the *Setup* Program).

If the Hard Disk Activity Light Does Not Work

If the hard disk activity light does not flicker when the PC is accessing the hard disk drive:

- Check that the control panel connector is firmly attached to the system board.
- Check that the disk power and data cables are correctly connected.

NOTE

If you are using a hard disk drive with a controller board (a SCSI hard disk, for example), the activity light does **not** flicker when the PC is accessing the hard disk drive

If the CD-ROM Drive Has a Problem

WARNING

Be sure to disconnect the power cord and any telecommunication cables from your computer before you remove the cover to check the cable connections or jumper settings.

To avoid electric shock and harm to your eyes by laser light, do not open the CD-ROM drive enclosure. The CD-ROM drive should be serviced by qualified service personnel only. Do not attempt to make any adjustment of the unit. This PC is a class 1 laser product.

No Sound from the CD-ROM Drive

If you are having problems with sound when playing a CD:

- Check that the volume control (if present) on the CD-ROM drive front panel is not set to the minimum.
- Ensure that the disk in the CD-ROM drive is an audio disk and not a Photo CD or data CD.
- If using headphones or external speakers, check that they are properly connected.
- Check that the CD audio cable is correctly installed and is connected to the system board.

CD-ROM Drive is Idle

If the CD-ROM drive does not appear to be working, try accessing the disk by clicking on the CD-ROM drive icon or drive letter assigned to the CD-ROM drive by your operating system.

3 Troubleshooting Your PC

If Your PC Has a Hardware Problem

CD-ROM Drive Does Not Work

- Check that the cables have been properly connected.
- Check that a CD is inserted in the drive.
- Verify that the CD-ROM is declared as "CD" in the *Setup* program (refer to the IDE Devices Submenu of the Configuration Menu in the *Setup* Program).
- Verify that the **Bus IDE Adapters** item is set to **Both** in *Setup* (refer to the IDE Devices Submenu of the Configuration Menu in the *Setup* Program).
- If you intend to boot on CD-ROM, make sure that this option is enabled in *Setup* (refer to the Start-up Center Submenu of the Security Menu in the *Setup* Program).
- For further information refer to the CD-ROM documentation.

If an Accessory Board Does Not Work

Carry out the following checks:

- Ensure the board has been firmly installed in the accessory board slot.
- Check that the accessory board has been correctly configured with the ISA Configuration Utility if necessary.
- Ensure the board is not using memory, I/O addresses, an IRQ, or DMA also used by the PC. Refer to "IRQs, DMAs, and I/O Addresses Used by Your PC", on page 51. Refer to the board's manual for further details.
- Check that the PC has been configured correctly in *Setup*.
- If the problem persists, refer to HP support.

If Your PC Has a Software Problem

If You Have Forgotten Your Password

- ❑ If you forget the User Password, but not the Administrator password, carry out the following procedure:
 - 1 Switch off the PC.
 - 2 Restart the PC. If the keyboard is locked, enter the administrator password.
 - 3 Wait for **F2=Setup** to be displayed.
 - 4 Press **(F2)** to start *Setup*.
 - 5 Enter the Administrator Password to access the **Security/User Password** menu.
 - 6 Move to the User Password field and set a new User Password. This will replace the old password which you had forgotten.
 - 7 Press **(F3)** to save the new Password and exit *Setup*.
- ❑ If you forget both the User Password and the Administrator Password:
 - 1 Switch off the PC.
 - 2 Remove the computer's cover.
 - 3 Set switch 7 on the system board switch block to CLOSED.
 - 4 Switch on the PC and allow it to complete its startup routine.

The message "Passwords have been cleared, power-off your PC and set switch 7 to open position before restarting" will be displayed.
 - 5 Switch off the computer.
 - 6 Reset switch 7 to OPEN.
 - 7 Replace the computer's cover.
 - 8 Switch on the PC and allow it to complete its startup routine.
 - 9 After the Power-On Self-Test has completed, press **(F2)** when prompted to use *Setup*.
 - 10 Set new User and System Administrator Passwords.
 - 11 Press **(F3)** to save the new passwords and exit *Setup*.

3 Troubleshooting Your PC

If Your PC Has a Software Problem

If Your Application Software Does Not Work

If the PC reports the system is OK and the indicator light over the power switch is illuminated, but some software won't run:

- Refer to the operating system and application software manuals.
- If Windows does not run properly, refer to the Windows manual for guidance.

If the Date and Time are Incorrect

The date and time can be incorrect for the following reasons:

- the time has changed for the seasons
- the PC has been unplugged from the power too long, and the battery is discharged.

To change the date and time, use your operating system utilities or the *Setup* program.

If Your PC Has an Audio Problem

No Sound When Running Any Applications

First, check that the output volume is not set to zero. Use the volume control on the front panel. Make sure the headphones are not connected directly to the CD-ROM drive (see the connection information in chapter 1).

Remember also that plugging the headphones into the front panel cuts out sound to the internal speaker and to external speakers connected to the audio Stereo Out jack.

When your PC starts up, the integrated audio interface may have no IRQ or DMA settings. These settings are initialized by software upon startup. Your system files may not have the necessary entries. Run the Setup program to configure the IRQ and DMA settings.

Absence of sound can also be caused by a hardware conflict. Hardware conflicts occur when two or more peripheral devices compete for the same signal lines or channels. Conflicts between your audio interface and another peripheral device might be due to the settings of the I/O addresses, IRQ channel, or DMA channel. To resolve the conflict, change the settings either of the audio interface or of any other ISA accessory in your system.

No Output from the 8- bit or 16-bit Digitized Sounds

This might be due to the DMA channel selected. If you hear no output from both the 8-bit and 16-bit digitized sounds, this might be due to an interrupt conflict. Use the HP Setup program or your operating system's audio control software to change the audio interface's DMA channel or IRQ setting.

The Volume is Too Low

The computer has two output jacks, Stereo Out on the rear of the computer and a headphones jack on the front panel, which provide the same output signal. This is a low-distortion output that cannot drive (without amplification) low-impedance devices such as speakers. If you plug devices with a low-impedance (less than 32 ohms) into the Stereo Out jack or the headphones jack, the volume will be low.

3 Troubleshooting Your PC

If Your PC Has an Audio Problem

Audio Input from the Microphone is Too Low, or No Audio At All Check that the microphone specifications meet the requirements of the 16-bit sound components. The microphone should be a 600-ohm dynamic type.

Humming Noise If the power grounding of your audio components is inadequate, a humming noise may be generated. This may happen if your PC is connected to a hifi system. Plug all devices into adjacent power outlets (outlets within 5 cm / 2 inches of each other), or use line filters.

Occasional Crackles When Playing Back Sounds These crackles are usually the result of your PC being unable to transfer audio samples within the required time. A solution is to use a lower sampling rate. Recording and playing back at 22 kHz is less demanding upon system resources than recording audio at 44 kHz.

The PC Hangs While Recording Uncompressed digital audio can eventually fill your hard disk. For example, one minute of stereo sound recorded at a resolution of 44 kHz will occupy about 10.5 MB. Before recording, check that there is enough free space on your hard disk.

Data compression can reduce the space required. The A-law and μ -law hardware compression used by the audio interface enables the sampling of sound at a resolution of 16-bits, but it generates the same quantity of data as an 8-bit sample.

MS-DOS Games Give "Not enough memory" Errors

Many games require a large amount of base memory and may not execute if many drivers or TSR (Terminate and Stay Resident) programs are installed. You may solve this problem by loading device drivers and TSRs into high memory. Refer to your MS-DOS manual for details of how to do this.

Changing the Battery

WARNING

There is a danger of explosion if the battery is incorrectly installed. For your safety, never attempt to recharge, disassemble, or burn the old battery. Replace the battery only with the same or equivalent type recommended by the manufacturer. The battery in this PC is a lithium battery which does not contain heavy metals, nevertheless, in order to protect the environment, do not dispose of batteries in household waste. Please return used batteries to the shop from which you bought them, or to the dealer from whom you purchased your PC, or to HP, so that they can either be recycled or disposed of in an environmentally sound way. Returned used batteries will be accepted free of charge.

You should order replacement battery HP 1420-0356 from your local Sales and Service office, or the equivalent "CR2032", which is available from most local stores.

3 Troubleshooting Your PC

Changing the Battery

After removing the computer's cover and the air flow guide:

- 1 Remove the old battery by sliding it from under the retaining clip (note the position of the cross).

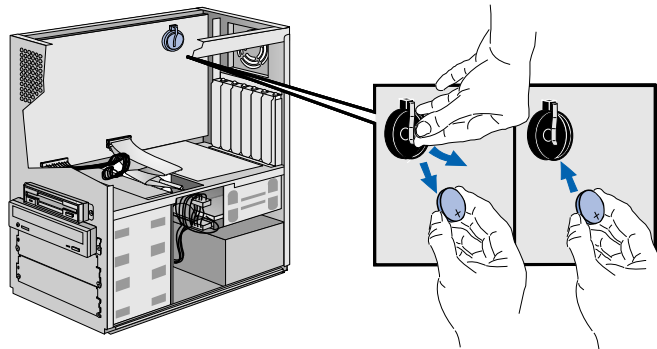

- 2 Place the new battery in the battery holder, with the cross in the same position as the old battery, and ensure that it is properly seated. Ensure that the clip is in place and holds the battery firmly.

You can also install an external battery (HP part number 1420-0513), which you can order from your authorized reseller. Install the external battery as follows:

- 1 After removing the computer's cover, connect the external battery cable to the battery connector on the system board.
- 2 Mount the external battery on the chassis near the fan, using the self-adhesive strip supplied.

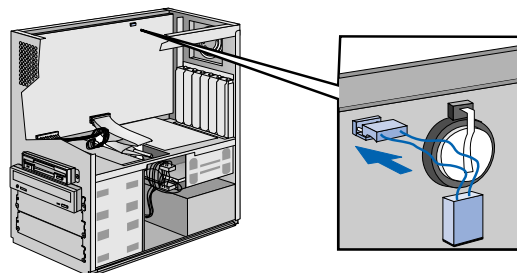

After installing either a replacement or an external battery, replace the computer's cover and run the *Setup* program to reconfigure the computer.

Technical Information Needed for Troubleshooting

System Board Switches

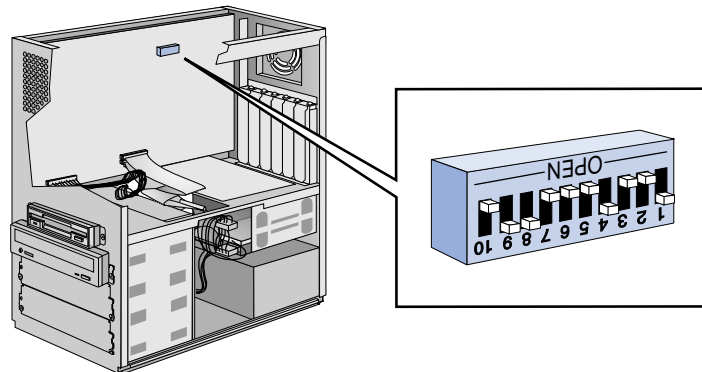

Switch	Switch function:
1 - 5	Processor speed, see next table
6	Clear setup configuration: Open = Normal operation (default) Closed = Clear CMOS
7	Clear Passwords: Open = Normal operation (default) Closed = Clear User and Administrator passwords
8	Keyboard power-on: Open = disabled Closed = enabled (default)
9-10	Reserved for test. Set to Open for normal operation (default setting)

Processor Frequency	Bus Frequency	Switch 1	Switch 2	Switch 3	Switch 4	Switch 5
180 MHz	60 MHz	Closed	Open	Open	Closed	Open
200 MHz	66 MHz	Open	Open	Open	Closed	Open
233 MHz	66 MHz	Open	Open	Open	Closed	Closed
266 MHz	66 MHz	Open	Open	Closed	Open	Open

3 Troubleshooting Your PC

Technical Information Needed for Troubleshooting

Power Consumption

All measurements are in watts (rms).

	Consumption at 115V / 60Hz		Consumption at 230V / 50Hz	
	180 MHz	200 MHz	180 MHz	200 MHz
Off	1.3	1.3	1.4	1.5
Windows NT¹ with HDD Accessories	55.2	55.5	54.5	54.6

1. No sleep mode, suspend mode or any APM available under Windows NT.

NOTE

When the PC is turned off with the power button on the front panel, the power consumption falls below 5 Watts, but is not zero. The special on/off method used by this PC considerably extends the lifetime of the power supply. To reach zero power consumption in "off" mode, either unplug the PC from the power outlet or use a power block with a switch.

Typical Power Consumption/Availability for ISA Accessory Slots

+5 V	4.5A limit per slot (limited by system board)
+12 V	1.5A limit per slot (limited by system board)
-5 V	0.1A total power limit (limited by power supply)
-12 V	0.3A total power limit (limited by power supply)

Typical Power Consumption/Availability for PCI Accessory Slots

+5 V	4.5A maximum per slot
+12 V	0.5A maximum per slot
-12 V	0.1A maximum per slot

There is a maximum per-slot limit of 25 W between all supply rails.

3 Troubleshooting Your PC

Technical Information Needed for Troubleshooting

IRQs, DMAs, and I/O Addresses Used by Your PC

<p>IRQs used by PC</p> <p>The IRQ, DMA, and I/O address mappings shown here are for a PC with a basic configuration. The resources used by your PC may vary, depending upon which accessory boards are bundled with the PC.</p>	<table border="0"> <tr><td>IRQ0</td><td>system timer</td></tr> <tr><td>IRQ1</td><td>keyboard</td></tr> <tr><td>IRQ2</td><td>system cascade</td></tr> <tr><td>IRQ3</td><td>free if not used for serial port 2</td></tr> <tr><td>IRQ4</td><td>free if not used for serial port 1</td></tr> <tr><td>IRQ5</td><td>free if not used for parallel port 2</td></tr> <tr><td>IRQ6</td><td>flexible disk drive controller</td></tr> <tr><td>IRQ7</td><td>free if not used for parallel port 1</td></tr> <tr><td>IRQ8</td><td>real-time clock</td></tr> <tr><td>IRQ9</td><td>available for PCI devices, if not used by ISA board</td></tr> <tr><td>IRQ10</td><td>available for PCI devices, if not used by ISA board</td></tr> <tr><td>IRQ11</td><td>available for PCI devices, if not used by ISA board</td></tr> <tr><td>IRQ12</td><td>mouse</td></tr> <tr><td>IRQ13</td><td>co-processor</td></tr> <tr><td>IRQ14</td><td>integrated IDE hard disk drive controller</td></tr> <tr><td>IRQ15</td><td>free if not used by second IDE controller</td></tr> </table>	IRQ0	system timer	IRQ1	keyboard	IRQ2	system cascade	IRQ3	free if not used for serial port 2	IRQ4	free if not used for serial port 1	IRQ5	free if not used for parallel port 2	IRQ6	flexible disk drive controller	IRQ7	free if not used for parallel port 1	IRQ8	real-time clock	IRQ9	available for PCI devices, if not used by ISA board	IRQ10	available for PCI devices, if not used by ISA board	IRQ11	available for PCI devices, if not used by ISA board	IRQ12	mouse	IRQ13	co-processor	IRQ14	integrated IDE hard disk drive controller	IRQ15	free if not used by second IDE controller
IRQ0	system timer																																
IRQ1	keyboard																																
IRQ2	system cascade																																
IRQ3	free if not used for serial port 2																																
IRQ4	free if not used for serial port 1																																
IRQ5	free if not used for parallel port 2																																
IRQ6	flexible disk drive controller																																
IRQ7	free if not used for parallel port 1																																
IRQ8	real-time clock																																
IRQ9	available for PCI devices, if not used by ISA board																																
IRQ10	available for PCI devices, if not used by ISA board																																
IRQ11	available for PCI devices, if not used by ISA board																																
IRQ12	mouse																																
IRQ13	co-processor																																
IRQ14	integrated IDE hard disk drive controller																																
IRQ15	free if not used by second IDE controller																																
<p>DMAs used by PC</p>	<table border="0"> <tr><td>DMA 0</td><td>free</td></tr> <tr><td>DMA 1</td><td>free if not used for parallel port in <i>Setup</i></td></tr> <tr><td>DMA 2</td><td>flexible disk drive controller</td></tr> <tr><td>DMA 3</td><td>free if not used for parallel port in <i>Setup</i></td></tr> <tr><td>DMA 4</td><td>used to cascade DMA channels 0-3</td></tr> <tr><td>DMA 5</td><td>free</td></tr> <tr><td>DMA 6</td><td>free</td></tr> <tr><td>DMA 7</td><td>free</td></tr> </table>	DMA 0	free	DMA 1	free if not used for parallel port in <i>Setup</i>	DMA 2	flexible disk drive controller	DMA 3	free if not used for parallel port in <i>Setup</i>	DMA 4	used to cascade DMA channels 0-3	DMA 5	free	DMA 6	free	DMA 7	free																
DMA 0	free																																
DMA 1	free if not used for parallel port in <i>Setup</i>																																
DMA 2	flexible disk drive controller																																
DMA 3	free if not used for parallel port in <i>Setup</i>																																
DMA 4	used to cascade DMA channels 0-3																																
DMA 5	free																																
DMA 6	free																																
DMA 7	free																																
<p>I/O Addresses used by PC</p>	<p>2Eh - 2Fh, integrated I/O controller 96h - 97h, "Little Ben" E0h - E7h, HP reserved 170h - 177h, 376h IDE secondary channel 1F0h - 1F7h, 3F6h IDE primary channel 278h - 27Fh parallel port 2 2E8h - 2EFh serial port 4 2F8h - 2FFh serial port 2 378h - 37Fh parallel port 1 3B0h - 3DFh integrated video graphics controller 3E8h - 3EFh serial port 3 3F0h - 3F5h, 3F7h integrated flexible disk controller 3F8h - 3FFh serial port 1 496h - 497h HP reserved 678h - 67Dh parallel port if ECP mode is selected 778h - 77Dh parallel port if ECP mode is selected</p>																																

3 Troubleshooting Your PC

The HP Summary Screen and Setup Program

The HP Summary Screen and *Setup* Program

This section introduces the HP Summary Screen and the HP *Setup* program. You can use the Summary Screen and the *Setup* program to configure your PC and solve configuration problems with your PC

HP Summary Screen

Check your PC's configuration when you first use the PC and each time after you install, remove, or upgrade accessories. To check the configuration:

- 1 Turn on the display and then the PC. If the PC is already turned on, save your data and exit all programs, then restart the PC. Consult your operating system documentation for any special instructions concerning turning off and then restarting your PC.
- 2 While the *Vectra* logo appears on your display, press **[Esc]**. This will take you to the HP Summary Screen. (To go immediately into the *Setup* program, and bypass the Summary Screen, press **[F2]** instead of **[Esc]**). The Summary Screen will appear for only a short time. To retain the screen indefinitely (until you decide to leave it), press **[F5]**.

3 Troubleshooting Your PC
The HP Summary Screen and Setup Program

When you press **[Esc]**, the HP Summary Screen, similar to the following one, will appear:

VA/6xxx - Copyright 1995 Hewlett-Packard - GZ.xx.xx			
BIOS Version	: GZ.xx.xx	PC Serial Number	: FR54011111
CPU Date Code	: N/A		
System RAM	: 16 MB	COM1	: 3F8H (Serial A)
Bank A	: 8 MB (EDO)	COM2	: 2F8H (Serial B)
Bank B	: None	COM3	: None
Bank C	: None	COM4	: None
Video RAM	: 1 MB	LPT1	: 378H
System Cache	: None	LPT2	: None
Video Device	: Matrox	LPT3	: None
1st IDE Device	: HDD 848 MB	Flexible Disk A	: 1.44 MB
2nd IDE Device	: None	Flexible Disk B	: None
3rd IDE Device	: None	Display type	: Not Available
4th IDE Device	: None		
ISA PnP	: Not Installed	PCI Slot #1	: Not Installed
ISA PnP	: Not Installed	PCI Slot #2	: Not Installed
ISA PnP	: Not Installed	PCI Slot #3	: Not Installed
		PCI Slot #4	: Not Installed
< F1 > to continue, < F2 > to run Setup, < F10 > to power off, < F5 > to retain			

This screen gives you a summary of the current configuration settings of your PC.

Using the HP Setup Program

- 1 Turn on the display and then the PC. If the PC is already turned on, save your data and exit all programs, then restart the PC. Consult your operating system documentation for any special instructions concerning turning off and then restarting your PC.

3 Troubleshooting Your PC

The HP Summary Screen and Setup Program

- 2 Press **F2** while **F2=Setup** is displayed at the bottom of the screen. **F2=Setup** appears for a short period, during the POST (Power-On-Self-Test). If you fail to press **F2** in time and the start-up process continues, you will need to restart your PC to go through the POST again so you can press **F2**.
- 3 A display of the PC's *Setup* program will appear, similar to the one below. Note that "Main" is initially highlighted.

PhoenixBIOS Setup – Copyright 1985-95 Phoenix Technologies Ltd. Copyright 1995 Hewlett-Packard Rev. GZ.xx.xx					
Main	Configuration	Security	Power	Exit	
Running Windows 95 [No]					Item-Specific Help
System Time		[13:06:48]			If you are not running Windows 95, the BIOS setup program will offer you some of the Windows 95 features and optimize the use of hardware resources.
System Date		[11/16/1995]			
Key click		[On]			
Key auto-repeat speed		[21.8 per Second]			
Delay before auto-repeat		[0.5 Second]			
Numlock at POWER-ON		[On]			
F1 Help	↑ ↓	Select Item	F7/F8	Change Values	F9 Setup Defaults
ESC Exit	← →	Select Menu	Enter	Select > Sub-Menu	F10 Previous Values













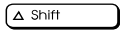









NOTE



In addition to the Exit menu, you can also use the **F3** key to save your settings and exit the *Setup* program.



3 Troubleshooting Your PC

The HP Summary Screen and Setup Program

You move through the *Setup* program by using the following keys:

- The  or  arrows,  and  or  keys can be used to select fields in the current menu.
- The  key moves to the previous page and the  key moves to the next page in a scrollable menu.
- The  key moves to the top item, and the  key moves to the bottom item, of the current menu.
- Within a field  selects the next lower value and  selects the next higher value.
-  displays a sub-menu for menu items marked with a solid right arrow ▶.
-  or  +  allows you to exit from a sub-menu.
- The  and  arrows select menus from the menu bar.
-  loads factory-installed default values.
-  restores previous values from CMOS.
-  or  +  displays the general help screen.
-  exits from the general help screen.
- Use the  key to save your settings and exit *Setup*.

Pressing the  or  arrow keys while you are on a main menu screen, will take you to the next menu option. If, however, you are on a sub-menu screen and you press these arrows, you will stay on that screen.

Use the  and  arrow keys to scroll through the items on the general help screen.

3 Troubleshooting Your PC
The HP Summary Screen and Setup Program

Hewlett Packard Support and Information Services

4 Hewlett Packard Support and Information Services

Your HP Authorized Reseller

Your HP Authorized Reseller

HP Authorized Resellers have been trained on HP Vectra equipment and are familiar with its configuration and environment. Authorized Resellers can also answer questions regarding non-HP hardware, software and systems as well as answer queries about usage not intended for, or not commonly used with the HP Vectra.

HP SupportPack

HP's three-year SupportPack is available from your local reseller. It must be purchased within 30 days of purchasing your HP Vectra. The concept of SupportPack is simple. It allows you to extend your one-year on-site hardware warranty to a three-year on-site hardware warranty, offering next day on-site response.

HP Support Assistant CD-ROM

HP Support Assistant is a yearly subscription service on CD-ROM. Each CD-ROM contains information about Vectra PCs as well as other HP computing products. The types of information you can find include:

- Product manuals, service and technical reference manuals
- Troubleshooting, installation and configuration information
- Drivers and utilities.

4 Hewlett Packard Support and Information Services
Hewlett-Packard Information Services

Subscriptions to HP Support Assistant can be obtained with an order form which is available from the HP FIRST Faxback system. Request document number 9025 (US and Asia Pacific) or 19025 (Europe). Subscriptions can also be obtained by contacting the following numbers:

Region	Phone Number	Fax Number
Asia-Pacific	+ 65 740-4477	+ 65 740-4499
Europe	+ 31 (55) 384279	+ 31 (55) 434455
Latin America	+ 1 (317) 364-8882	+ 1 (317) 364-8888
US/Canada	1 (800) 457-1762	+ 1 (317) 364-8888

Hewlett-Packard Information Services

Hewlett Packard Electronic Information Services are available 24 hours per day, 7 days per week.

HP Forum on CompuServe

The HP Systems Forum on CompuServe is an on-line service, accessible via modem. This service provides information about your HP PC, and allows you to communicate with other HP users through an on-line user forum. HP users share their knowledge and experience with you.

You can also download the latest versions of drivers, BIOS and software utilities for HP Vectra PCs.

As a preferred Hewlett Packard customer, you are invited to join CompuServe at no initial charge.

4 Hewlett Packard Support and Information Services

Hewlett-Packard Information Services

For the United States and the United Kingdom, call the number shown below and ask for representative 51. For all other locations, first call the worldwide number to obtain the number of your local sales office, then call your local sales office and ask for representative 51.

Country	Local Call / Freephone Number	Direct Number
United States	1 (800) 848-8199	+ 1 (614) 529-1349
United Kingdom	(0800) 289378	+ 44 (1272) 760680
Worldwide	—	+ 1 (614) 529-1349

CompuServe will send you a free introductory membership immediately, including information on how to access CompuServe.

If you use the WinCIM graphical interface, choose **GO** from the Services menu or click on the **GO** icon on the Ribbon. In the **GO . . .** dialog box, type **HP** and then click on the **OK** button.

If you use a command-driven interface, at the CompuServe **!** prompt, type **GO HP**.

HP Forum on America Online

The HP Forum on America Online is an electronic information and communication service which can be accessed via modem.

To access the HP Forum, in the keyword search menu, type **HP**.

This will load the HP Home Page directly onto your screen.

In the HP Forum you can ask and answer questions about HP products and you can also download drivers, software application notes, or utilities for HP products.

Membership information can be obtained by calling 1(800) 827-6364, giving the preferred customer number 1118.

4 Hewlett Packard Support and Information Services
Hewlett-Packard Information Services

HP BBS Library

The HP electronic bulletin board library service contains the latest versions of drivers, BIOS, and utilities, which you can download to your PC using a modem. Support documentation is also available.

Country	Number	Baud Rate
United States	+ 1 (208) 344-1691	300, 1200, 2400, 4800, 9600, 14400
United Kingdom	+ 44 (1344) 3600880	up to 14400
Worldwide	+ 1 (208) 344-1691	300, 1200, 2400, 4800, 9600, 14400

Set your modem for no parity, 8 data bits, and 1 stop bit (N, 8, 1).

Internet—FTP Library Service

Hewlett-Packard provides a library service which offers the latest versions of drivers, BIOS and utilities and other information about HP products. This library service is available if you have FTP access to the Internet, whatever your location.

Alias ftp-boi.external.hp.com
Name anonymous
Password Enter your E-mail address

Access HP World Wide Web Site

Access HP, HP's World Wide Web site gives you access to information about HP, its products, including product data sheets, service and support information, electronic newsletters and technical tips. You can also download the latest versions of drivers, BIOS and software utilities.

World-Wide Web URL <http://www.hp.com>

4 Hewlett Packard Support and Information Services

Hewlett-Packard Information Services

HP FAXback on Demand—HP FIRST

HP FIRST is a service where you can select documents, support and technical information, data sheets and pre-sales information, which are then faxed to you. To access this service, you can use a touch-tone phone and have the fax sent to the fax machine of your choice, or use the handset on your fax machine and dial one of the numbers given below:

Country/Region	Number	Access Method
United States/Canada	1 (800) 333-1917	Phone or fax
U.K.	(0800) 960271	Phone or fax
Australia	+ 61 (3) 9272-2627	Phone or fax
Singapore	+ 65 291-7951	Phone or fax
Hong Kong	+ 852 2506-2422	Phone or fax
New Zealand	+ 64 (9) 356-6642	Phone or fax
Europe	+ 31 (20) 681-5792	Phone or fax
Worldwide	+ 1 (208) 344-4809	Fax

A complete description of Hewlett-Packard electronic services is provided in document #9020.

HP Audio Tips (USA only) HP Automated Support Directory

HP Audio Tips is an automated system containing recordings which can direct you to Hewlett Packard support services. Live support is not available through this service.

Dial 1 (800) 333-1917 and press 3, to access HP Audio Tips.

4 Hewlett Packard Support and Information Services

Hewlett-Packard Information Services

Ordering Drivers and BIOS on Diskette

You can order diskettes from HP, with the latest versions of drivers, BIOS and software utilities. The diskettes will be delivered by mail.

Information for ordering diskettes is set out in the table below:

North and Latin America	Europe
Phone + 1 (970) 339 7009 Monday - Saturday 24 hours per day	Phone + 44 (1429) 865511 Monday - Friday 8.30 a.m. - 6.00 p.m. Central European Time
Fax + 1 (970) 330 7655	Fax + 44 (1429) 866000
Mail US Driver Fulfillment for Hewlett-Packard PO Box 1754, Greeley, Colorado 80632 USA	Mail European Fulfillment for Hewlett-Packard c/o StarPak International, Ltd., Hartlepool, Cleveland, TS25 2YP United Kingdom

Australia	Asia - Pacific
Phone + 61 (2) 565 6099 Monday - Friday 8.30 a.m. - 5.30 p.m. Australian Eastern Time	Phone + 65 740 4477 Monday - Friday 8.30 a.m. - 5.30 p.m. Singapore Time
Fax + 61 (2) 519 5631	Fax + 65 740 4499
Mail Fulfill: Plus Pty Ltd., Private Bag 75, Alexandria NSW Australia 2015	Mail Fulfill: Plus Pte Ltd., No 51, Ubi Ave. 3, Singapore 1440

4 Hewlett Packard Support and Information Services

HP Support Services

HP Support Services

Hewlett-Packard provides a three year hardware warranty which includes on-site service during the first year after purchase, and a return service during the second and third years after purchase.

HP telephone support for your Vectra PC is available during the first year of your hardware warranty. This service will also provide technical assistance with the basic configuration and setup of your Vectra PC and for the pre-loaded operating system.

WARNING

The HP telephone support service does NOT provide free telephone support for PCs configured as network servers. If you do configure your PC as a network server, you are advised to contact your HP reseller to purchase a network phone-in support contract, which will provide you with a fee-based telephone support service.

Hewlett-Packard Telephone Support

HP North American Customer Support Center Assistance from the HP North American Customer Support Center is available during normal business hours.
The number is: +1 (970) 635-1000

HP European Customer Support Center Assistance from the HP European Customer Support Center is available in English, Monday to Friday, 8:30 am to 6:00 pm Central European time, except Wednesday when the hours are 8.30 am to 4:00 pm.
The number is: +31 (20) 581-3330

Other Regions Contact your reseller who will be able to help you, or direct you to the appropriate HP telephone support service.

Lifeline Telephone Support (U.S. Only)

Lifeline is a fee-based telephone support program for Vectra PCs available after the one-year telephone support provided as part of the hardware warranty has expired.

In the US please call the appropriate number listed below.

Number	Method of Payment	Charge Type
1 (900) 555-1500	Charged to phone bill	per minute rate
1 (800) 999-1148	Charged to credit card	Flat fee

4 Hewlett Packard Support and Information Services

HP Network Phone-in Support Service (NPS)

HP Network Phone-in Support Service (NPS)

The HP Network Phone-in Support Service (NPS) provides fast access to HP experts in networked Multivendor environments. It can help you:

- resolve complex network problems
- leverage HP's alliances with leading Network Operating Systems and Network manufacturers
- support your HP and non-HP products with a single telephone call.

To obtain an HP NPS contract, contact your HP authorized reseller, or if you are in the US call (800) 437-9140.

Hewlett-Packard Marketing Headquarters

Should you wish to contact Hewlett-Packard, check your local telephone directory for the HP Sales and Service Office near you. If you cannot find a convenient HP office, you can write to one of the major HP Sales and Service Offices or one of the Worldwide Marketing Headquarters listed here.

<p>ASIA Far East Sales Region Hdqtrs Hewlett-Packard Asia Ltd. 22/F Peregrine Tower Lipp Centre 89 Queensway, Central Hong Kong</p>	<p>LATIN AMERICA Hewlett-Packard Latin Am. Hdqtrs Monte Pelvoux 111 Lomas de Chapultepec 11000 Mexico D.F.</p>	<p>USA Intercon Operations Hdqtrs Hewlett-Packard Company 3495 Deer Creek Road P.O. Box 10495 Palo Alto, CA 94303-0896 USA</p>
<p>EUROPE European Operations Hdqtrs Hewlett-Packard S.A. 150, route du Nant-d'Avril P.O. Box 1217 Meyrin 2/Geneva Switzerland</p>	<p>MIDDLE EAST / AFRICA Middle East / Central Africa Sales Hdqtrs Hewlett-Packard S.A. Rue de Veyrot 39 CH-1217 Meyrin 1/Geneva Switzerland</p>	<p>CANADA Hewlett-Packard Ltd. 6877 Goreway Drive Mississauga Ontario L4V 1M8 Canada</p>

Glossary

adapter An accessory board, that connects to the system board via an accessory board slot.

BBS Bulletin Board System. A computer that uses a modem and software to serve as an information source for other computers equipped with a modem. Hewlett-Packard has a BBS that can be reached at +1 (408) 553-3500.

BIOS Basic Input-Output System. Software that provides an interface between the computer hardware and the operating system.

bus An electrical connection over which information is transported.

cache A block of high-speed memory used for the temporary storage of data.

CD-ROM Compact Disc Read Only Memory. A mass storage device that uses compact disc technology. CDs can store data, but most cannot be written to.

CMOS memory An area of your computer's memory whose contents are preserved when you turn off the computer. CMOS memory stores information that must be maintained, such as your computer's configuration.

controller A device that enables another device (such as a hard disk) to communicate with the computer.

device driver Software that enables the computer to interface with a specific peripheral, such as a printer or display.

EPA energy star program A standard for power management which requires automatic power-down to less than 30 W.

expansion slot A slot inside the computer, connected to the system board, that can be used for accessory boards.

extended memory Memory which can be addressed by the processor in the area of memory above the first 1 MB.

HP Utilities Software provided by Hewlett-Packard to perform certain tasks, for example, changing the date and time.

IDE Integrated Device Electronics. An interface standard for communications between the computer and a hard disk or CD-ROM.

IRQ Interrupt Request. A signal, which, when received by the processor, halts the current process and allows a different task to be undertaken.

jumper An electrically-conductive part that is used to connect two or more points on a circuit board. Commonly used to select configuration options.

Glossary

mass storage Any device used to store large amounts of data. Usually refers to hard disks and tape backup units.

memory modules Miniature boards containing memory chips. Used for increasing the amount of memory available in the computer.

multimedia Combining static media (such as text and pictures) with dynamic data (such as sound, video, and animation) on the same system.

network server mode A security feature that prevents unauthorized use of an input device (like a keyboard or mouse) while your computer is running as an unattended network server.

pixel Picture element. The smallest addressable spot on the screen.

POST Power-On-Self-Test. A series of tests your computer performs when you switch the computer on.

RAM Random Access Memory. This memory is used to hold programs and data temporarily.

resolution A measure of the visible detail on a screen or printout. Screen resolution is measured in 'pixels across' by 'pixels down' by 'number of colors'. Printer resolution is measured in dpi (dots-per-inch).

ROM Read-Only Memory. Computer memory used to store parts of the computer's operating system permanently. ROM chips can contain instructions and data.

SCSI Small Computer System Interface. A high-speed data bus used for connecting hard disks, tape drives, and other accessories to your computer.

SCSI chain Devices connected on a single SCSI bus.

Setup program Used to inform the computer about its configuration, for example the amount of memory installed. The setup program is stored in ROM on the system board.

shadow RAM A method of relocating the system and/or video BIOS from slower ROM chips to faster RAM to improve system performance.

SIMM Single In-line Memory Module. A small board containing several RAM chips.

terminator A resistor at the end of a SCSI cable that prevents the signal from reflecting back along the cable.

video controller A chip or expansion card which converts signals in the computer into displayable signals.

video RAM Memory that enables or speeds up drawing to the screen or increases resolution or color options.

Index

- A**
- accessories
 - installing, 11-??
 - accessory board
 - installing, 26
 - problems, 42
 - Accessory boards, configuring in Windows 3.11, 26
 - air flow guide, 14
 - America Online
 - HP Forum, 60
 - audio
 - connectors, 4
 - problems, 45
- B**
- BBS library
 - access numbers, 61
 - BIOS
 - obtaining via FTP, 61
 - obtaining via HP BBS, 61
 - obtaining via World Wide Web, 61
 - ordering by mail, 63
 - updating video BIOS, 18
- C**
- cables
 - keyboard, 3
 - CD-ROM drive
 - installing, 24
 - CD-ROM drive, does not work, 41
 - Changing the battery, 47
 - CompuServe
 - free introductory membership, 59
 - HP forum, 59
 - connecting
 - display, 3
 - keyboard, 3
 - power cables, 5
 - connectors
 - audio, 4
 - headphones, 4
 - microphone, 4
 - MIDI, 4
 - printer, 3
 - cover
 - replacing, 13
 - cover, removing, 13
- D**
- disconnecting from power, iv
 - display
 - connecting, 3
 - DMA Channels
 - used by the PC, 51
 - drivers
 - obtaining via FTP, 61
 - obtaining via HP BBS, 61
 - obtaining via World Wide Web, 61
 - ordering by mail, 63
- E**
- error message, 35
- F**
- flexible disk drive
 - installing, 24
 - problems, 40
 - FTP access to HP, 61
- G**
- glossary, 67
- H**
- hard disk
 - problems, 40
 - headphones jack
 - location of connector, 4
 - Hewlett-Packard
 - BBS library, 61
 - FTP access, 61
 - information services, 59
 - marketing headquarters, 66
 - support and information services, 57
 - World Wide Web access, 61
 - HP Forum
 - on America Online, 60
 - on CompuServe, 59
- I**
- I/O addresses
 - used by the PC, 51
 - IDE drives, 19
 - installing, 22
 - replacing, 22
 - information services, 59
 - Installing
 - main memory, 15
 - memory, 15
 - installing
 - accessories, 11-??
 - accessory boards, 26
 - CD-ROM drive, 24
 - flexible disk drive, 24
 - IDE drives, 22
 - mass storage devices, 19
 - printer, 3
 - processor upgrade, 29
 - tape drive, 24
 - Installing memory, 15
 - Interrupt Request Channels
 - used by the PC, 51
- J**
- jumper location, 49
- K**
- keyboard
 - connecting, 3
 - keyboard, problems, 37
- L**
- LINE IN jack
 - location of connector, 4
 - LINE OUT jack
 - location of connector, 4
- M**
- mass storage devices
 - connectors, 19
 - installing, 19
 - Memory
 - installing, 15
 - memory
 - installing main memory, 15
 - microphone
 - location of connector, 4
 - MIDI
 - connector, 4
 - mouse
 - problems, 39
- N**
- network
 - telephone support, 66

P
parallel port
 location, 3
password
 setting, 7
PC
 starting, 6
 stopping, 6
PC, unpacking, 2
power
 disconnecting from, iv
power cables, connecting, 5
printer
 connector, 3
 installing, 3
 problems, 39
problems
 with accessory board, 42
 with software, 43
 with the audio interface, 45
 with the flexible disk drive, 40
 with the hard disk, 40
 with the printer, 39
processor upgrade
 installing, 29

R
removing the cover, 13
replacing
 IDE drives, 22
Replacing cover, 13

S
serial port
 location, 3
setting
 passwords, 7
Setup program, 52
SETUP, can't change values, 34
software
 problems, 43
starting
 PC, 6
Starting and Stopping Your PC, 6
stopping
 PC, 6
support
 by telephone, 65
 information services, 57
 Network Phone-in Support, 66
Support Assistant
 ordering information, 58
switch location, 49
System board, 49
system board, 49
 jumper location, 49
 switch location, 49
System board, switches, 49

T
tape drive, installing, 24
telephone support
 for networks, 66
 out of warranty, 65
 under warranty, 65
tools required for installation, 2
troubleshooting, 31

U
unpacking the PC, 2
URL
 for HP World Wide Web site, 61

V
video board
 flash BIOS, 18

W
World Wide Web
 access to HP, 61

Regulatory Information and Warranty

Regulatory Information

DECLARATION OF CONFORMITY according to ISO/IEC Guide 22 and EN 45014

Manufacturer's Name and Address:

HEWLETT-PACKARD
Boulevard Steve Biko
38090 Villefontaine
FRANCE

Declares that the product:

Product Name: Personal Computer
Model Number: HP Vectra VA G/xxx MT

Conforms to the following Product Specifications:

SAFETY: International: IEC 950: 1991 + A1 + A2 + A3
Europe: EN 60950: 1992 + A1 + A2
EN 60825-1994

EMC International: CISPR 22: 1993 Class B

Europe: EN 55022: 1994 Class B
EN 50082-1: 1992
IEC 555-2:1982 + A1:1985 / EN 60555-2:1987
IEC 1000-3-3:1994 / EN 61000-3-3:1995
IEC 801-2: 1992 / prEN 55024-2: 1992 - 4 kV CD, 8 kV AD
IEC 801-3: 1984 / prEN 55024-3: 1991 - 3 V/m
IEC 801-4: 1988 / prEN 55024-4: 1992 - 0.5 kV Signal Lines,
1 kV Power Lines

Supplementary information: The product herewith complies with the requirements of the EMC Directive 89/336/EEC amended by the directive 93/68/EEC, of the Low Voltage Directive 73/23/EEC, and carries the CE marking accordingly.

Grenoble
July 1996

Jean-Marc JULIA
Product Quality Manager

FCC (for USA only)

Federal Communications Commission Radio Frequency Interference Statement

Warning:

This equipment has been tested and found to comply with the limits for a Class B digital device, pursuant to Part 15 of the FCC Rules. These limits are designed to provide reasonable protection against harmful interference in a residential installation. This equipment generates and uses, and can radiate radio frequency energy and, if not installed and used in accordance with the instructions, may cause harmful interference to radio communications. However, there is no guarantee that interference will not occur in a particular installation. If this equipment does cause harmful interference to radio or television reception, which can be determined by turning the equipment off and on, the user is encouraged to correct the interference by one or more of the following measures:

- reorient or relocate the receiving antenna
- increase the separation between the equipment and the receiver
- connect the equipment into an outlet on a circuit different from that to which the receiver is connected
- consult the dealer or an experienced radio/TV technician for help.

Hewlett-Packard's system certification tests were conducted with HP-supported peripheral devices and HP shielded cables, such as those you receive with your system. Changes or modifications not expressly approved by Hewlett-Packard could void the user's authority to operate the equipment.

Notice for Canada

This Class B digital apparatus meets all requirements of the Canadian Interference-Causing Equipment Regulations.

Cet appareil numérique de la Class B respecte toutes les exigences du Règlement sur le matériel brouilleur du Canada.

Safety Warning for the USA and Canada

If the power cord is not supplied with the computer, select the proper power cord according to your local national electric code.

USA: use a UL listed type SVT or SJT detachable power cord.

Canada: use a CSA certified detachable power cord.

For your safety, never remove the PC's cover without first removing the power cord and any connection to a telecommunication network. Always replace the cover before switching on again.

Si le cordon secteur n'est pas livré avec votre ordinateur, utiliser un cordon secteur en accord avec votre code électrique national.

USA: utiliser un cordon secteur "UL listed", de type SVT ou SJT.

Canada: utiliser un cordon secteur certifié CSA.

Pour votre sécurité, ne jamais retirez le capot de l'ordinateur sans avoir préalablement débranché le cordon secteur et toute connexion à un réseau de télécommunication. N'oubliez pas de replacer le capot avant de rebrancher le cordon secteur.

Changing a battery

There is a danger of explosion if the battery is incorrectly installed. For your safety, never attempt to recharge, disassemble or burn the old battery. Replace the battery only with the same or equivalent type recommended by the manufacturer. The battery in this PC is a lithium battery which does not contain heavy metals, nevertheless, in order to protect the environment, do not dispose of batteries in household waste. Please return used batteries to the shop from which you bought them, to the dealer from whom you purchased the PC, or to Hewlett Packard, so that they can either be recycled or disposed of in an environmentally sound way. Returned used batteries will be accepted free of charge.



Bij dit apparaat zijn batterijen geleverd. Wanneer deze leeg zijn, moet U ze niet weggooien maar inleveren als KCA.

Changement de la pile

Il y a danger d'explosion lorsque la pile n'est pas installé correctement. Pour votre sécurité, ne jamais essayer de recharger, de démonter ou de brûler l'ancienne pile. Remplacer uniquement avec une batterie du même type ou d'un type équivalent recommandé par HP. La pile dans cet ordinateur est une pile au lithium qui ne contient pas de métaux lourds, néanmoins, afin de protéger l'environnement, il ne faut pas jeter les piles dans les ordures ménagères. Il faut les rendre au magasin ou vous les avez achetées, au revendeur où vous avez acheté l'ordinateur, ou à Hewlett Packard, pour qu'elles soient recyclées ou stockées de manière qui ne nuit pas à l'environnement. Les piles usées seront acceptées gratuitement.

Notice for the United Kingdom

The HP Vectra PC is approved under approval number NS/G/1234/J/100003 for indirect connection to Public Telecommunication Systems within the United Kingdom.

Noise Declaration for Germany

Lärmangabe nach Maschinenlärmmverordnung - 3 GSGV (Deutschland)
LpA < 70 db am Arbeitsplatz normaler Betrieb nach EN27779: 11.92.

Notice for Japan

この装置は、第二種情報装置（住宅地域又はその隣接した地域において使用されるべき情報装置）で住宅地域での電波障害防止を目的とした情報処理装置等電波障害自主規制協議会（VCCI）基準に適合しております。

しかし、本装置をラジオ、テレビジョン受信機に近接してご使用になると、受信障害の原因となることがあります。

取扱説明書に従って正しい取り扱いをして下さい。

Notice for Korea

이 기기는 비업무용으로 전자파장애검정을 받은 기기로서 주거지역에서는 물론 모든 지역에서 사용할 수 있습니다.

HP Hardware Warranty

Important: This is your hardware product warranty statement. Read it carefully.

Warranty terms may be different in your country. If so, your Authorized HP Dealer or Hewlett-Packard Sales and Service Office can give you details.

Three Year Limited Hardware Warranty

Hewlett-Packard (HP) warrants this hardware product against defects in materials and workmanship for a period of three years from receipt by the original end-user purchaser.

The three year warranty includes on-site service during the first year of use, and return service provided by an HP Service Center or a participating Authorized HP Personal Computer Dealer Repair Center, during the second and third years of use.

If HP receives notice of above defined defects during the warranty period, HP will either, at its option, repair or replace products which prove to be defective.

Should HP be unable to repair or replace the product within a reasonable amount of time, the customer's alternate exclusive remedy shall be a refund of the purchase price upon return of the product.

Limitation of Warranty

The above warranty shall not apply to defects resulting from: misuse; unauthorized modification; operation or storage outside the environmental specifications for the product; in-transit damage; improper maintenance; or defects resulting from use of non-HP software, accessories, media, supplies, consumables, or such items not designed for use with the product.

HP makes no other express warranty, whether written or oral, with respect to this product.

Any implied warranty of merchantability or fitness is limited to the three-year duration of this written warranty.

Some states or provinces do not allow limitations on how long an implied warranty lasts, so the above limitation or exclusion may not apply to you.

This warranty gives you specific legal rights, and you may also have other rights which vary from state to state, or province to province.

Limitation of Liability and Remedies

The remedies provided above are the customer's sole and exclusive remedies.

In no event shall HP be liable for any direct, indirect, special, incidental, or consequential damages, whether based on warranty, contract, tort, or any other legal theory.

The foregoing limitation of liability shall not apply in the event that any HP product sold hereunder is determined by a court of competent jurisdiction to be defective and to have directly caused bodily injury, death, or property damage; provided, that in no event shall HP's liability for property damage exceed the greater of \$50,000 or the purchase price of the specific product that caused such damage.

Some states or provinces do not allow the exclusion or limitation of incidental or consequential damages—including lost profit—so the above limitation or exclusion may not apply to you.

Obtaining On-Site Warranty Service

To obtain on-site warranty service, the customer must contact an HP Sales and Service Office (in the US, call the HP Customer Support Center at (303) 635-1000) or a participating Authorized HP Personal Computer Dealer Repair Center and arrange for on-site repair of the product. The customer must be prepared to supply proof of the purchase date.

This warranty is extended worldwide to products purchased from HP or an Authorized HP Personal Computer Dealer which are reshipped by the original purchaser either for use by the original purchaser or provided as an incidental part of systems integrated by the original purchaser. Service is provided in the same manner as if the product was purchased in the country of use and can only be provided in countries where the product is designed to operate. If the product is not normally sold by HP in the country of use, it must be returned to the country of purchase for service.

The system processor unit, keyboard, mouse, and Hewlett-Packard accessories inside the system processor unit—such as video adapters, mass storage devices, and interface controllers—are covered by this warranty.

Customer-replaceable components—such as the keyboard or mouse—may be serviced through expedited part shipment. In this event, HP will prepay shipping charges, duty, and taxes; provide telephone assistance on replacement of the component; and pay shipping charges, duty, and taxes for any part that HP asks to be returned.

HP products external to the system processor unit—such as external storage subsystems, displays, printers, and other peripherals—are covered by the applicable warranties for those products; HP software is covered by the HP Software Product Limited Warranty.

On-site visits caused by non-Hewlett-Packard products—whether internal or external to the system processor unit—are subject to standard per-incident travel and labor charges.

On-site service for this product is restricted or unavailable in certain locations. In HP Excluded Travel Areas—areas where geographical obstacles, undeveloped roads, or unsuitable public transportation prohibit routine travel—service is provided on a negotiated basis at extra charge.

Response time for HP on-site service in an HP Service Travel Area is normally next business day (excluding HP holidays) for HP Travel Zones 1-3 (generally 100 miles or 160 Km from the HP office). Response time is second business day for Zones 4 and 5 (200 miles, 320 Km); third business day for Zone 6 (300 miles, 480 Km); and negotiated beyond Zone 6. Worldwide Customer Support Travel information is available from any HP Sales and Service Office.

Travel restrictions and response time for dealer or distributor service are defined by the participating dealer or distributor.

Service contracts which provide after-hour or weekend coverage, faster response time, or service in an Excluded Travel Area are often available from HP, an authorized dealer, or authorized distributor at additional charge.

Customer Responsibilities

The customer may be required to run HP-supplied diagnostic programs before an on-site visit or replacement part will be dispatched.

The customer is responsible for the security of its proprietary and confidential information and for maintaining a procedure external to the products for reconstruction of lost or altered files, data, or programs.

For on-site service, the customer must provide: access to the product; adequate working space and facilities within a reasonable distance of the product; access to and use of all information and facilities determined necessary by HP to service the product; and operating supplies and consumables such as the customer would use during normal operation.

When service is being performed on-site, a representative of the customer must be present at all times. The customer must state if the product is being used in an environment which poses a potential health hazard to repair personnel; HP or the servicing dealer may require that the product be maintained by customer personnel under direct HP or dealer supervision.

Obtaining Return Warranty Service

When return warranty service applies, the product must be returned to a service facility designated by HP. Customer must enclose a copy of a document proving date of purchase.

The customer shall prepay shipping charges (and shall pay all duty and taxes) for products returned to HP for warranty service. HP shall pay for return of products to the customer except for products returned to the customer from another country.

HP products may contain remanufactured parts equivalent to new in performance or may have been subject to incidental use.

HP Software Product License Agreement and Software & Product Limited Warranty

The HP Software Product License Agreement and Product Limited Warranty shall govern all Software which is provided to you, the Customer, as part of the HP computer product. This HP Software Product Agreement and Product Limited Warranty shall supersede any non-HP software license or warranty terms which may be found in any documentation or other materials contained in the computer product packaging.

CAREFULLY READ THIS LICENSE AGREEMENT BEFORE PROCEEDING TO OPERATE THIS EQUIPMENT. RIGHTS IN THE SOFTWARE ARE OFFERED ONLY ON THE CONDITION THAT THE CUSTOMER AGREES TO ALL TERMS AND CONDITIONS OF THE LICENSE AGREEMENT. PROCEEDING TO OPERATE THE EQUIPMENT INDICATES YOUR ACCEPTANCE OF THESE TERMS AND CONDITIONS. IF YOU DO NOT AGREE TO THE LICENSE AGREEMENT, YOU MUST NOW EITHER REMOVE THE SOFTWARE FROM YOUR HARD DISK DRIVE AND DESTROY THE MASTER DISKETTES, OR RETURN THE COMPLETE COMPUTER AND SOFTWARE FOR A FULL REFUND.

Software License Agreement

In return for payment of the applicable fee, Hewlett-Packard grants the Customer a license in the software, subject to the following:

- 1 USE. Customer may use the software on any one computer. Customer may not network the software or otherwise use it on more than one computer. Customer may not reverse assemble or decompile the software unless authorized by law.
- 2 COPIES AND ADAPTATIONS. Customer may make copies or adaptations of the software (a) for archival purposes or (b) when copying or adaptation is an essential step in the use of the software with a computer so long as the copies and adaptations are used in no other manner.
- 3 OWNERSHIP. Customer agrees that he/she does not have any title or ownership of the software, other than ownership of the physical media. Customer acknowledges and agrees that the software is copyrighted and protected under the copyright laws. Customer acknowledges and agrees that the software may have been developed by a third party software supplier named in the copyright notices included with the software, who shall be authorized to hold the Customer responsible for any copyright infringement or violation of this Agreement.
- 4 TRANSFER OF RIGHTS IN SOFTWARE. Customer may transfer rights in the software to a third party only as part of the transfer of all rights and only if Customer obtains the prior agreement of the third party to be bound by the terms of this License Agreement. Upon such a transfer, Customer agrees that his/her rights in the software are terminated and that he/she will either destroy his/her copies and adaptations or deliver them to the third party.
- 5 SUBLICENSING AND DISTRIBUTION. Customer may not lease, sublicense the software or distribute copies or adaptations of the software to the public in physical media or by telecommunication without the prior written consent of Hewlett-Packard.
- 6 TERMINATION. Hewlett-Packard may terminate this software license for failure to comply with any of these terms provided Hewlett-Packard has requested Customer to cure the failure and Customer has failed to do so within thirty (30) days of such notice.
- 7 UPDATES AND UPGRADES. Customer agrees that the software does not include updates and upgrades which may be available from Hewlett-Packard under a separate support agreement.
- 8 EXPORT CLAUSE. Customer agrees not to export or re-export the software or any copy or adaptation in violation of the U.S. Export Administration regulations or other applicable regulation.
- 9 U.S. GOVERNMENT RESTRICTED RIGHTS. Use, duplication, or disclosure by the U.S. Government is subject to restrictions as set forth in subparagraph (c)(1)(ii) of the Rights in Technical Data and Computer Software clause in DFARS 252.227-7013. Hewlett-Packard Company, 3000 Hanover Street, Palo Alto, CA 94304 U.S.A. Rights for non-DOD U.S. Government Departments and Agencies are as set forth in FAR 52.227-19(c)(1,2).

(Rev. 0795)

Software Product Limited Warranty

Ninety-Day Limited Software Warranty

HP warrants for a period of NINETY (90) DAYS from the date of the purchase that the software product will execute its programming instructions when all files are properly installed. HP does not warrant that the operation of the software will be uninterrupted or error free. In the event that this software product fails to execute its programming instructions during the warranty period, Customer's remedy shall be a refund or repair. Should HP be unable to replace the media within a reasonable amount of time, Customer's alternate remedy shall be a refund of the purchase price upon return of the product and all copies.

Removable Media (If supplied)

HP warrants the removable media, if supplied, upon which this product is recorded to be free from defects in materials and workmanship under normal use for a period of NINETY (90) DAYS from the date of purchase. In the event the media proves to be defective during the warranty period, Customer's remedy shall be to return the media to HP for replacement. Should HP be unable to replace the media within a reasonable amount of time, Customer's alternate remedy shall be a refund of the purchase price upon return of the product and destruction of all other nonremovable media copies of the software product.

Notice of Warranty Claims

Customer must notify HP in writing of any warranty claim not later than thirty (30) days after the expiration of the warranty period.

Limitation of Warranty

HP makes no other express warranty, whether written or oral with respect to this product. Any implied warranty of merchantability or fitness for a particular purpose is limited to the 90-day duration of this written warranty. Some states or provinces do not allow limitations on how long an implied warranty lasts, so the above limitation or exclusion may not apply to you.

This warranty gives specific legal rights, and you may also have other rights which vary from state to state, or province to province.

Limitation of Liability and Remedies

THE REMEDIES PROVIDED ABOVE ARE CUSTOMER'S SOLE AND EXCLUSIVE REMEDIES. IN NO EVENT SHALL HP BE LIABLE FOR ANY DIRECT, INDIRECT, SPECIAL, INCIDENTAL OR CONSEQUENTIAL DAMAGES (INCLUDING LOST PROFIT) WHETHER BASED ON WARRANTY, CONTRACT, TORT OR ANY OTHER LEGAL THEORY. Some states or provinces do not allow the exclusion or limitation of incidental or consequential damages, so the above limitation or exclusion may not apply to you.

Obtaining Warranty Service

Warranty service may be obtained from the nearest HP sales office or other location indicated in the owner's manual or service booklet.

Consumer transactions in Australia and the United Kingdom: The disclaimers and limitations above shall not apply and shall not affect the statutory rights of a Consumer.





Part Number D4210-90001
Printed in USA 5/96



Free Manuals Download Website

<http://myh66.com>

<http://usermanuals.us>

<http://www.somanuals.com>

<http://www.4manuals.cc>

<http://www.manual-lib.com>

<http://www.404manual.com>

<http://www.luxmanual.com>

<http://aubethermostatmanual.com>

Golf course search by state

<http://golfingnear.com>

Email search by domain

<http://emailbydomain.com>

Auto manuals search

<http://auto.somanuals.com>

TV manuals search

<http://tv.somanuals.com>