

PULSE GENERATOR 8082A

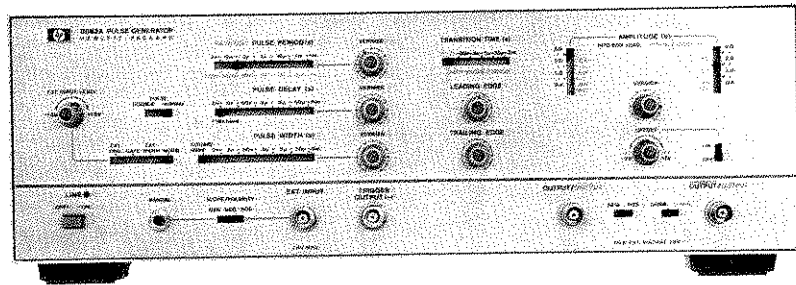

OPERATING AND SERVICE MANUAL

8082A

PULSE GENERATOR

SERIAL NUMBERS

This manual applies directly to instrument with serial number 1822G02846 and higher. Any change made in instruments having serial numbers higher than the above number will be found in a "Manual Changes" supplement supplied with this manual. Be sure to examine the supplement for changes which apply to your instrument and record these changes in the manual. Backdating information for instruments with lower serial numbers can be found in Section 7 (yellow pages).

c HEWLETT-PACKARD GMBH 1983
HERRENBERGER STR. 110, D-7030 BOBLINGEN
FEDERAL REPUBLIC OF GERMANY

MANUAL PART No. 08082-90003
MICROFICHE PART No. 08082-90503

PRINTED: SEP 1983

Printed in the Federal Republic of Germany

SAFETY SUMMARY

The following general safety precautions must be observed during all phases of operation, service, and repair of this instrument. Failure to comply with these precautions or with specific warnings elsewhere in this manual violates safety standards of design, manufacture, and intended use of the instrument. Hewlett-Packard Company assumes no liability for the customer's failure to comply with these requirements.

GENERAL — This is a Safety Class I instrument (provided with terminal for protective earthing) and has been manufactured and tested according to international safety standards.

OPERATION — BEFORE APPLYING POWER comply with the installation section. Additionally, the following shall be observed:

Do not remove instrument covers when operating.

Before the instrument is switched on, all protective earth terminals, extension cords, auto-transformers and devices connected to it should be connected to a protective earth via a ground socket. Any interruption of the protective earth grounding will cause a potential shock hazard that could result in serious personal injury. Whenever it is likely that the protection has been impaired, the instrument must be made inoperative and be secured against any unintended operation.

Make sure that only fuses with the required rated current and of the specified type (normal blow, time delay, etc.) are used for replacement. The use of repaired fuses and the short-circuiting of fuseholders must be avoided.

Adjustments described in the manual are performed with power supplied to the instrument while protective covers are removed. Energy available at many points may, if contacted, result in personal injury.

Any adjustment, maintenance, and repair of the opened instrument under voltage should be avoided as much as possible, and when inevitable, should be carried out only by a skilled person who is aware of the hazard involved. Do not attempt internal service or adjustment unless another person, capable of rendering first aid and resuscitation is present. Do not replace components with power cable connected.

Do not operate the instrument in the presence of flammable gases or fumes. Operation of any electrical instrument in such an environment constitutes a definite safety hazard.

Do not install substitute parts or perform any unauthorized modification to the instrument.

Capacitors inside the instrument may still be charged even if the instrument has been disconnected from its source of supply.

SAFETY SYMBOLS



The apparatus will be marked with this symbol when it is necessary for the user to refer to the instruction manual in order to protect the apparatus against damage.



Indicates dangerous voltages.



Earth terminal

WARNING

The **WARNING** sign denotes a hazard. It calls attention to a procedure, practice or the like, which, if not correctly performed or adhered to, could result in injury or loss of life. Do not proceed beyond a **WARNING** sign until the indicated conditions are fully understood and met.

CAUTION

The **CAUTION** sign denotes a hazard. It calls attention to an operating procedure, practice, or the like, which, if not correctly performed or adhered to, could result in damage to or destruction of part or all of the equipment. Do not proceed beyond a **CAUTION** sign until the indicated conditions are fully understood and met.

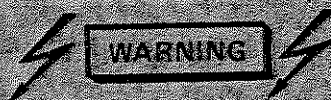

Dangerous voltages, capable of causing serious personal injury, are present in this instrument. Use extreme caution when handling, testing, and adjusting.



1-1 INTRODUCTION

1-2 The 8082A is a 250 MHz dual channel pulse source with variable leading and trailing edge transition times as fast as 1ns. It also has variable pulse frequency, delay, width, offset and amplitude. The normal/complement relationship and the polarity of either output can be reversed. Single pulse, double pulse and square wave operation are available. There are also four trigger modes:

1-3 **Normal Mode.** In this mode the 8082A operates as a self-contained pulse source with full control of the pulse parameters from the front panel controls.

1-4 **Ext Trig Mode.** In this mode the pulse and trigger output frequencies are determined by the frequency of an externally applied signal. The other pulse parameters are varied from the front panel controls.

1-5 **Gate Mode.** In this mode a gating signal enables the pulse and trigger outputs.

1-6 **External Width Mode.** In this mode the pulse frequency and width are determined by the frequency and width of an externally applied signal. The delay between input and output is fixed. The trigger output is the shaped trigger input signal.

1-7 ECL OUTPUT

1-8 The 8082A has an ECL position on each of its amplitude range switches. When either or both of the switches are set to this position, both 8082A outputs automatically deliver a fixed voltage swing of $-0.9V$ to $-1.7V$ typical (into an open circuit) for driving ECL logic.

Table 1-1 Specifications

These specifications apply when:

1) both outputs are terminated by a 50- Ω load,

2) the internal 50- Ω source impedance is selected.

PULSE CHARACTERISTICS (Source and load impedance 50 Ω)

Transition Times: \leq 1ns to 0.5ms in 6 ranges. First range from \leq 1ns to 5ns controls leading and trailing edges simultaneously. For all other ranges transition times variable independently up to 1:10.

Difference between risetime and fall-time is less than 25% of the faster transition time of the two.

Overshoot and Ringing: $\leq \pm 5\%$ of pulse amplitude may increase to $\pm 10\%$ with amplitude vernier CCW.

Preshoot: $\leq \pm 5\%$ of pulse amplitude.

Linearity: Linearity aberration for both slopes $\leq 5\%$ for transition times > 5 ns.

Output: Maximum amplitude is 5V from 50 Ω into 50 Ω . Maximum output voltage is ± 5 V (amplitude + offset).

Offset: $> \pm 2$ V, into 50 Ω

Baseline: 0V ± 150 mV with offset switched off and amplitude range set to maximum. Other amplitude ranges reduce baseline proportionately.

DC-Source Impedance: 50 $\Omega \pm 5\%$
Reflection Coefficient: Reflection is 2% typical for steps with 1ns rise time applied to output connector on all amplitude ranges except 5V range. On the 5V range, the reflection may be 15%.

Output protection: Cannot be damaged by open or short circuits or application of ext $\leq \pm 6$ volts, or ± 200 mA independent of control settings.

Attenuator: Two separate three step-attenuators reduce the outputs to 1V. Vernier is common for both outputs and reduces the output to 0.4V minimum. A further position provides ECL-compatible outputs (-0.9 V to -1.7 V typ. open circuit).

TIMING

Repetition Rate: > 250 MHz to < 1 kHz in 6 ranges.

Period Jitter: $< 0.1\% + 50$ ps

Delay: < 2 ns to > 0.5 ms in 6 ranges plus typ. 18ns fxd. with respect to trigger output.

Delay Jitter: $< 0.1\% + 50$ ps

Double Pulse: Up to 125 MHz max. (simulates 250MHz). Min pulse spacing ≥ 4 ns.

Delay Duty Cycle: $> 50\%$

Pulse Width: < 2 ns to > 0.5 ms in 6 ranges.

Width Jitter: $< 0.1\% + 50$ ps

Width Duty Cycle: $> 50\%$

Square Wave: A further position of the Pulse Width switch provides Square Wave output. (Delay and double pulse are disabled, max. Rep. Rate 250 MHz). Duty cycle is 50% $\pm 10\%$ up to 100 MHz, 50% $\pm 15\%$ for > 100 MHz.

Trigger Output: Negative going Square Wave (50% duty cycle typ.) > 500 mV from 50 Ω into 50 Ω . Internal 50 Ω load can be switched off by slide-switch on PC-board. Amplitude increases to ≥ 1 V into 50 Ω up to 200 MHz.

Trigger Output Protection: Cannot be damaged by short circuit or application of external ± 200 mA.

EXTERNALLY CONTROLLED OPERATION

External Input

Input Impedance: 50 $\Omega \pm 10\%$. DC coupled.

Maximum Input: ± 6 V

Trigger Level: Adjustable -1.5 V to $+1.5$ V.

Slope Control: Positive, negative or manual selectable. In the MAN-position all ext. functions can be controlled by push button. Button pushed in simulates an "on-signal".

Sensitivity: Sine-wave > 200 mVpp, pulses > 200 mV.

Repetition Rate: 0 to > 250 MHz.

Ext.-Controlled Modes

Ext. Trigger: There are approximately 7ns delay between the external input and the trigger output. Rep.-Rate is ext. controlled (is triggered by external signal). Trigger output provides the pulse-shaped input signal. Square wave mode is disabled.

Synchronous Gating: Gating signal turns rep. rate generator on. Last pulse is of normal width even if gate ends during the pulse.

External Width: Output pulse width determined by width of drive input. Rep. Rate and Delay are disabled. Trigger output provides shaped input signal.

OPTIONS

- | | |
|------------|-----------------------------------|
| Option 907 | Front Handle Kit |
| Option 908 | Rack Flange Kit |
| Option 909 | Rack Flange plus Front Handle Kit |
| Option 910 | Additional Instrument Manual |

GENERAL

Power Requirements: 100V, 120V, 220V, 240V (+5%, -10%) 48 - 440 Hz; Power consumption 85VA max.

Weight: Net 7.9 kg (17.44 lbs), shipping 8.9 kg (19.63 lbs).

Dimensions: 426mm wide, 145mm high, 380mm deep (16 3/4 ins. x 5 11/16 ins. x 15 ins.).



Figure 2-1. 8082A and Supplied Accessories

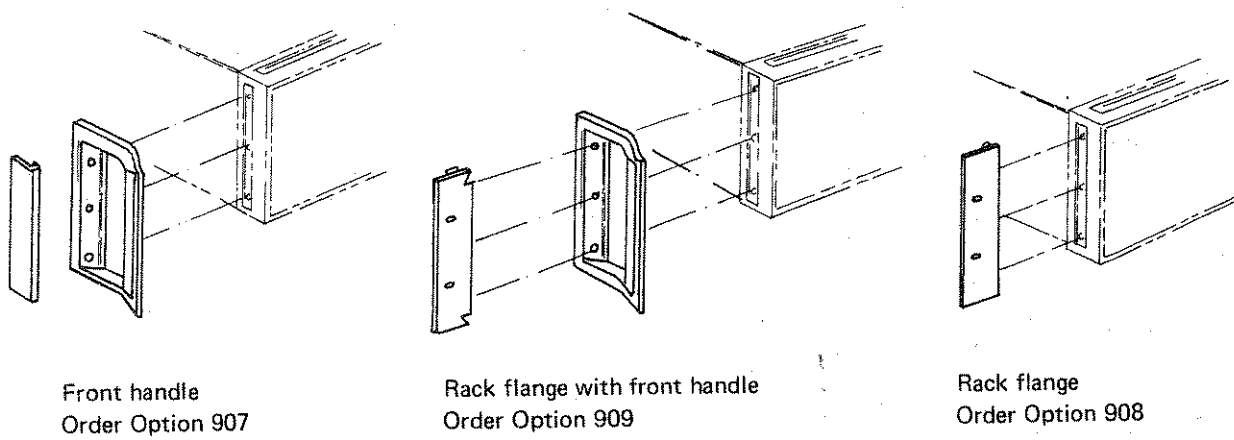

Front handle
Order Option 907

Rack flange with front handle
Order Option 909

Rack flange
Order Option 908

Figure 2-2. Available Accessories

2-1 GENERAL**2-2 Initial Inspection**

2-3 Inspect the instrument and accessories for physical damage, and if damage is evident, refer to paragraph 2-19 for the recommended claim procedure and repacking information.

2-4 Accessories

2-5 The following accessories are supplied with the standard instrument (Figure 2-1):

	HP Part Number
1A fuse (for 220/240V operation)	2110-0007
2A fuse (for 110/120V operation)	2110-0202
Power cord	see Figure 2-3
Operating and Service Manual	

For an additional manual, order option 910.

Handles or rack mounting flanges are delivered with the instrument only if the appropriate option (Figure 2-2) is ordered.

2-6 Power Cords

2-7 The instrument is supplied with one of the power cords shown in Figure 2-3.

2-8 INSTALLATION**2-9 Power Cord**

2-10 The 3-wire power cable supplied with the 8016A, when connected to the appropriate power outlet, grounds the instrument cabinet and panels. To preserve this safety feature when operating the instrument from an outlet without a ground connection, use an appropriate adapter and connect the ground lead (green/yellow) to an external ground.

2-11 If the plug on the cable does not fit your power outlet, then cut the cable at the plug end and connect a suitable plug. The plug should meet local safety requirements and include the following features:

- Minimum current rating of 2A
- Ground connection
- Cable clamp

The colour coding used in the cable will depend on the cable supplied (see Figure 2-3).

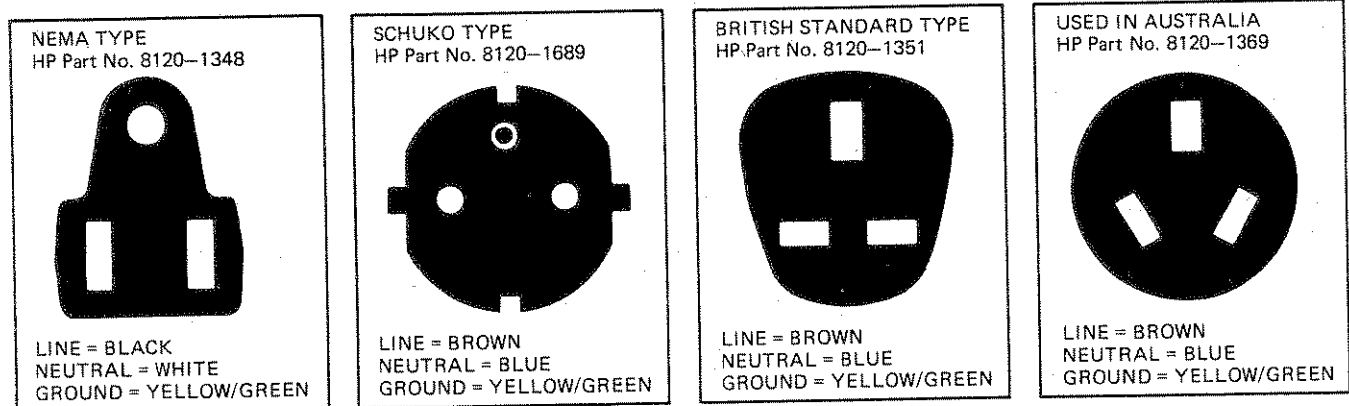

Figure 2-3. Power Cords

WARNING

To avoid the possibility of injury or death, the following precautions must be followed before the instrument is switched on:

- If this instrument is to be energized via an auto-transformer for voltage reduction, make sure that the ground connection is not interrupted.
- The power cable plug shall only be inserted into a socket outlet provided with a protective earth contact. The protective action must not be negated by the use of an extension cord without a protective conductor (grounding).
- The safety check (Table 5-27) shall be executed before connecting the instrument to the supply.

2-12 Power Source requirements

2-13 The instrument will operate from nominal ac line supplies of 100V, 120V, 220V or 240V (-10%, +5%) at 48 Hz to 66 Hz. Two switches on the rear panel allow one of the four voltages to be selected.

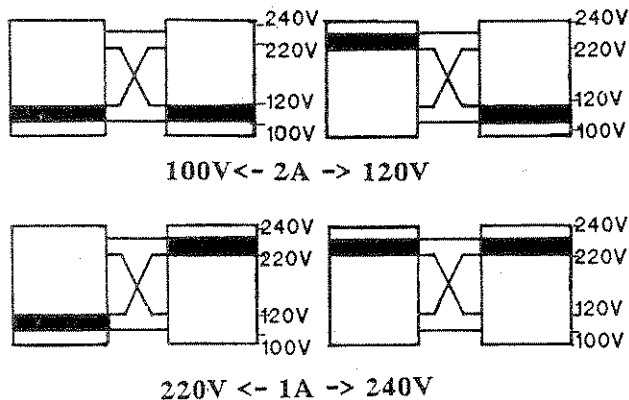

Figure 2-4. Switch Settings for the various Normal Powerline Voltages

CAUTION

Before applying power to the instrument, check on the rear panel that the switch is set in accordance with local supply conditions.

2-14 To check the power requirements proceed as follows:

- Remove the fuse and check its value:
for 220V/240V operation 1A
for 100V/120V option 2A
- Check that the line selector switch positions corresponds to the local supply voltage. If they do not correspond use a screwdriver to change the switch positions.
- Insert the correct fuse into the fuseholder.
- Connect the power cable to the rear connector.

2-15 Temperature Requirements

2-16 The instrument operates within specifications when the ambient temperature is between 0°C (32°F) and 50°C (122°F). The word generator may be stored between -40°C (-40°F) and 75°C (167°F).

2-17 RACK MOUNTING

2-18 Figure 2-2 shows the possible handle/rack-mounting configurations. If handles are fitted and subsequently need to be removed, the plastic trim must first be taken off as shown in Figure 2-5.

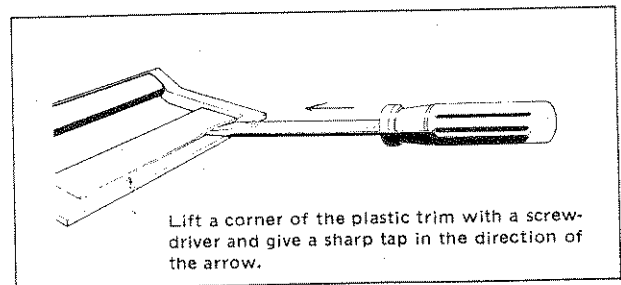

Figure 2-5. Removing Plastic Trim

2-19 CLAIMS AND REPACKAGING

2-20 Claims for Damage

2-21 If physical damage is evident or if the instrument does not meet specification when received, notify the carrier and the nearest Hewlett-Packard Sales/Service Office. The Sales/Service Office will arrange for repair or replacement of the unit without waiting for settlement of the claim against the carrier.

2-22 Repackaging for Shipment and Storage

2-23 If the instrument is to be shipped to a Hewlett-Packard Sales/Service Office, attach a tag showing owner, address, model and serial number, and the repair required. The original shipping carton and packaging material may be re-usable but the Hewlett-Packard Sales/Service Office will also provide information and recommendations on materials to be used if the original packing is not available or re-usable.

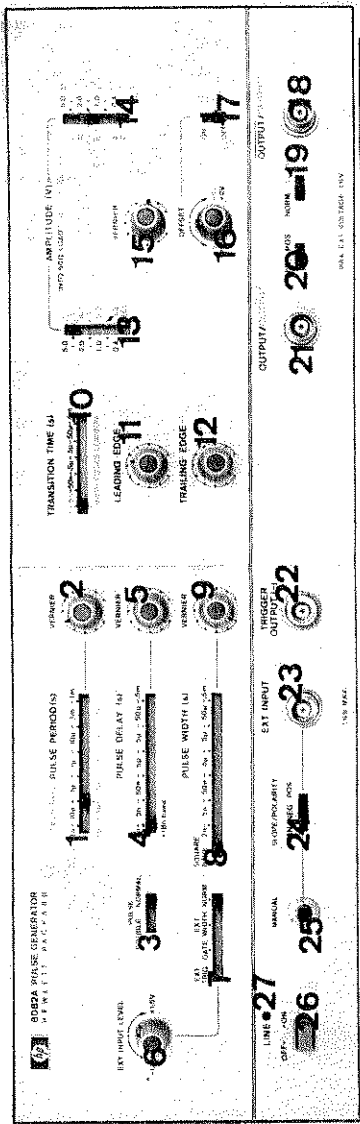

- 1 RATE switch: for selecting the range of the pulse rate.
- 2 Rate VERNIER: for continuous adjustment of the repetition rate within the range selected on the RATE switch. Clockwise rotation increases the pulse period (reduces the rate).
- 3 PULSE DOUBLE/NORMAL switch: in the DOUBLE PULSE position the 8082A delivers two pulses for every trigger pulse — one pulse in phase with the trigger output and one delayed by the amount set on the PULSE DELAY controls. DOUBLE PULSE is not available in the EXT WIDTH mode and is automatically inhibited if selected. In the NORMAL position, for each trigger pulse, the 8082A delivers one pulse which is delayed on the trigger pulse by the amount set on the PULSE DELAY controls.
- 4 PULSE DELAY switch: for selecting the range of the pulse delay with respect to the trigger output in NORM, GATE and EXT TRIG modes. Has no effect in the EXT WIDTH and SQUARE WAVE modes.
- 5 Pulse delay VERNIER: for continuous adjustment of the pulse delay within the range selected on the PULSE DELAY switch. Clockwise rotation increases the delay.
- 6 EXT INPUT LEVEL control: defines the threshold level of the EXTERNAL INPUT over a range $-1.5V$ to $+1.5V$.
- 7 Mode switch: selects either the internal (NORM) mode or one of three external modes (EXT WIDTH, GATE or EXT TRIG).
- 8 PULSE WIDTH switch: selects the range of the pulse width required in all modes except EXT WIDTH. When SQUARE WAVE is selected a square wave output of 50% duty cycle is produced. The frequency of the square wave depends on the PULSE PERIOD setting.
- 9 Pulse width VERNIER: for continuous adjustment of the pulse width within the range set on the PULSE WIDTH switch.
- 10 TRANSITION TIME switch: for selecting the range of leading and trailing edge transition times.
- 11 LEADING EDGE vernier: for continuous adjustment of the leading edge transition time within the range selected on the TRANSITION TIME switch. On the fastest range this vernier controls both leading and trailing edges.
- 12 TRAILING EDGE vernier: for continuous adjustment of the trailing edge transition time within the range selected on the TRANSITION TIME switch.
- 13 AMPLITUDE switch: for selecting the range of the output pulse amplitude available at the OUTPUT / OUTPUT connector. In the ECL position the OUTPUT / OUTPUT connector delivers pulses of fixed amplitude ($-0.9V$ to $-1.7V$ into an open circuit) and the amplitude vernier and the offset control are disabled.
- 14 AMPLITUDE switch: for selecting range of the output pulse amplitude available at the OUTPUT / OUTPUT connector. In the ECL position the OUTPUT / OUTPUT connector delivers pulses of fixed amplitude ($-0.9V$ to $-1.7V$ into an open circuit) and the amplitude vernier and the offset control are disabled.
- 15 Amplitude VERNIER: for continuous adjustment of pulse amplitude from both pulse outputs simultaneously within the ranges set on the AMPLITUDE switches.
- 16 OFFSET vernier: for adjustment of the baseline of both output pulses simultaneously over the range $-2V$ to $+2V$.
- 17 OFFSET switch: for enabling/disabling the OFFSET vernier. In the OFF position the baseline of both outputs is zero volts.
- 18 OUTPUT / OUTPUT connector: BNC connector.
- 19 NORM / COMPL switch: reverses the duty cycle of the two outputs, what was the normal output becomes the complement and vice versa.
- 20 NEG/POS switch: determines the polarity of both output pulses.
- 21 OUTPUT / OUTPUT connector: BNC connector.
- 22 TRIGGER OUTPUT (-) connector: BNC connector, supplies negative square wave at a rate determined by the setting of the pulse period controls. Pulse delay is referred to the negative going edge of the trigger. In EXT TRIG and EXT WIDTH modes it will deliver a shaped version of the trigger input. In GATE mode it will deliver pulses at the rate set on the pulse period controls for as long as the gate is open.
- 23 EXT INPUT connector: BNC connector to which trigger pulses are applied in the EXT TRIG, GATE and EXT WIDTH modes.
- 24 SLOPE / POLARITY switch determines whether a rising (POS) or falling (NEG) signal will trigger or gate the external input on. MANUAL position means that the external signal can be simulated by pressing the MANUAL button.
- 25 MANUAL button provides a means of initiating a single pulse (EXT TRIG mode) each time the button is pressed, a train of pulses (GATE mode) while the button is pressed, or a pulse whose width is equal to the time the button is pressed (EXT WIDTH mode).
- 26 LINE ON/OFF switch: press-for-on, press-for-off switch.
- 27 LINE lamp: glows when LINE ON/OFF switch is ON.

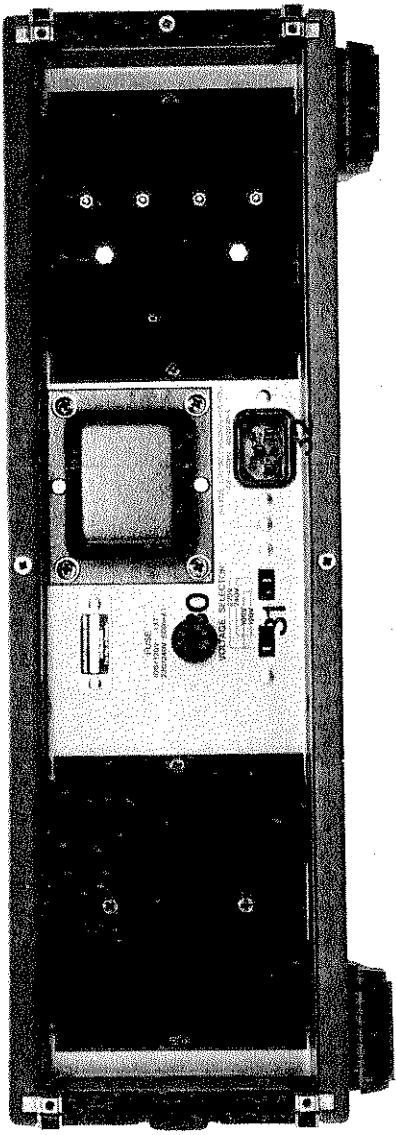

REAR PANEL

- 30 Fuse
- 31 Line voltage selector
- 32 Line connector

See Section 2

INTERNAL (See Figure 6-2)

- A351 Trigger output 50Ω internal load on/off.

Figure 3-1. Controls and Connectors

3-1 GENERAL

3-2 This section is divided into two parts. The first part gives some general notes on the operation of the 8082A together with operating instructions for each of the four operating modes:

- NORM operating mode
- EXT WIDTH operating mode
- GATE operating mode
- EXT TRIG operating mode

Full setting-up instructions are given for Normal mode followed by any changes in control settings required for the other three modes. Stylized waveforms are given for each mode to show the resultant pulse shapes. For ease

of operation the instructions will refer to Figure 3-1 which shows the controls identified by a reference number in a circle. The same reference numbers are used in the text when each control is mentioned.

3-3 The second part of this section gives applications information.

3-4 EXTERNAL INPUT CHARACTERISTICS

3-5 The SLOPE/POLARITY switch determines whether a rising (POS) or falling (NEG) signal will trigger or gate the external input on. Figure 3-2 shows the effects of these controls in the External Width mode.

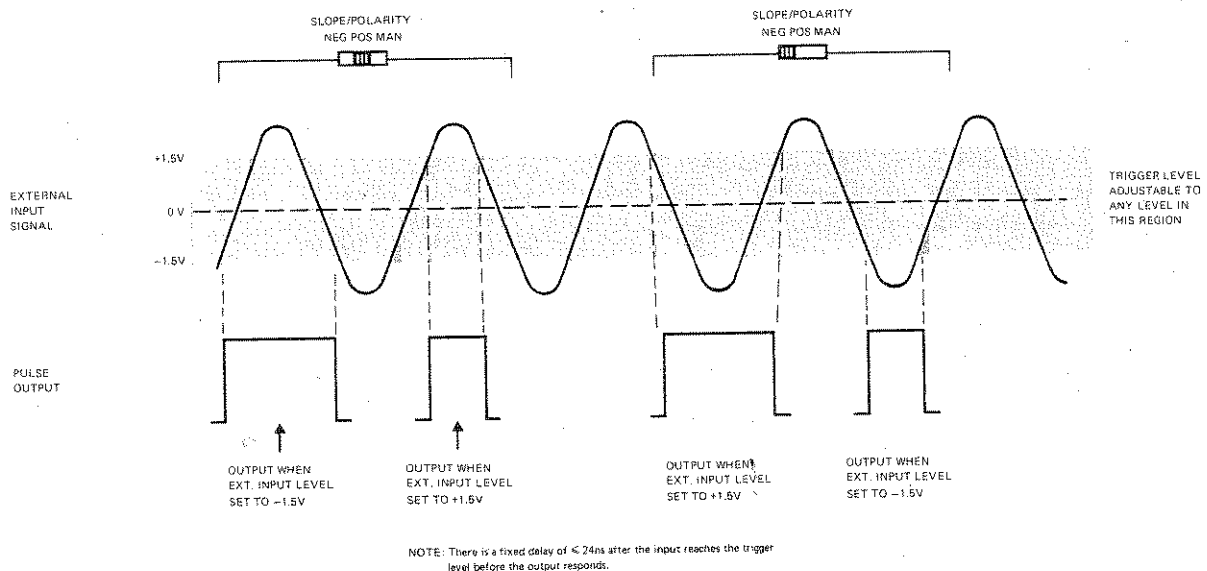

Figure 3-2. Effect of External Input Controls

3-6 Any external input pulses must have an amplitude of at least 200mV peak-to-peak and must be at least 2ns wide at the level at which triggering is to occur.

3-7 If the SLOPE/POLARITY switch is set to MAN, the external signal can be simulated by pressing the MANUAL pushbutton. This button provides a means of initiating a single pulse (EXT TRIG mode) each time the button is pressed, a train of pulses (GATE mode) while the button is pressed, or a pulse whose width is equal to the time the button is pressed (EXT WIDTH mode).

3-8 SQUARE WAVE OPERATION

3-9 There is a Square Wave facility on the 8082A which produces a square wave output of 50% duty cycle in NORMAL mode. If Square Wave is selected in External Trigger or External Width modes, the output is a pulse shaped version of the trigger input (the output waveforms are the same as for External Width mode, see Figure 3-4). If Square Wave is selected in Gate mode, the output is a gated square wave, the repetition rate of which is set up on the pulse period controls.

3-10 OUTPUT AMPLITUDE CONTROLS

3-11 Vernier

3-12 Because the amplitude vernier is common to both outputs, the amplitude relationship of one output to the other is 1:1, 1:2 or 1:5.

3-13 ECL Outputs

3-14 To obtain normal and complement ECL compatible pulses from the two outputs, either one or both amplitude range switches should be set to the ECL position. The ECL levels supplied are $-0.9V$ to $-1.7V$ into an open circuit, i.e. without an external 50 ohm load. These output levels can be altered by changing the values of resistors R 5 (ECL amplitude) and R60 (ECL-DC offset) on board A5 (Amplitude Vernier and DC Offset board).

3-15 INCOMPATIBLE CONTROL SETTINGS

3-16 When operating the 8082A, the layout of the Pulse Period, Delay and Width controls helps to avoid incompatible settings as shown in Figure 3-3. Generally, the Pulse Period control should be farthest right but the controls can all be in a straight vertical line if the Pulse Period vernier is more clockwise than the other two verniers.

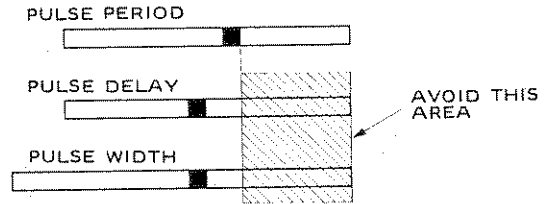

Figure 3-3. Positioning of Controls

3-17 NORM OPERATING MODE

3-18 In this mode the 8082A requires no external trigger signal to produce an output. Pulse rate, width, delay, transition times, amplitude and offset are all adjusted by the front panel controls.

3-19 The initial settings (listed below) are given to obtain a normal pulse waveform (Figure 3-4) for someone unfamiliar with the operation of the 8082A. Both pulse outputs and the trigger output should be connected to a high-frequency oscilloscope using a 50 ohm system. The oscilloscope (an HP 180C main-frame with 1810A plug-in or similar 1 GHz bandwidth sampling oscilloscope) should be set with the sweep time at $0.5\mu s/cm$ and with the sensitivity at $200mV/cm$.

LINE 26	ON
PULSE PERIOD 1	$1\mu-10\mu$
VERNIER 2	Mid-range
PULSE DELAY 4	$2n-5n$
VERNIER 5	CCW ($2n$)
PULSE WIDTH 8	$50n-.5\mu$
VERNIER 9	CW (1.5μ)
NORMAL/DOUBLE PULSE switch 3	NORMAL
Mode Switch 7	NORM
TRANSITION TIME 10	$50n-.5\mu$
LEADING EDGE 11	Mid-range
TRAILING EDGE 12	Mid-range
AMPLITUDE 13	$1.0-2.0$
AMPLITUDE 14	$1.0-2.0$
VERNIER 15	CCW (1.0)
OFFSET ON/OFF switch 17	OFF
NORM/COMPL switch 19	NORM
NEG/POS switch 20	POS

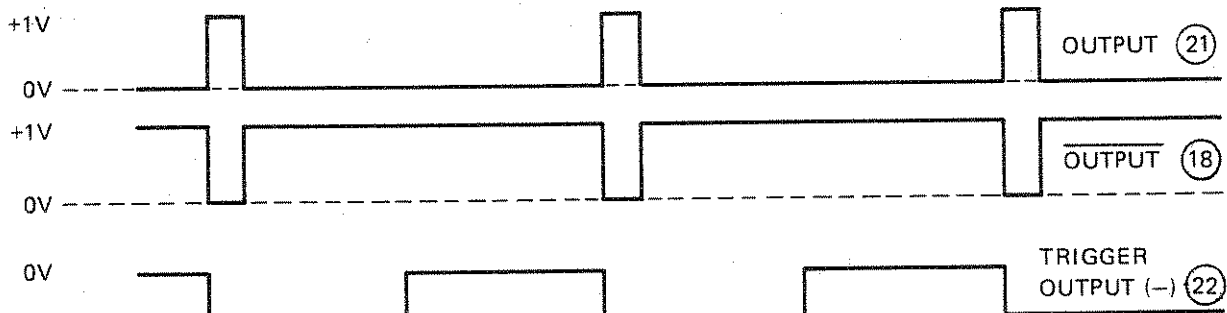

Figure 3-4. Pulse Output in NORM Mode

3-20 EXT WIDTH OPERATING MODE

3-21 In External Width mode, the pulse repetition rate and width are determined by the repetition rate and width (at the threshold set by the EXT INPUT LEVEL control) of an externally applied signal. In EXT WIDTH mode the PULSE PERIOD controls, the PULSE DELAY controls, the PULSE WIDTH controls and the DOUBLE/NORMAL PULSE switch have no effect on the pulse output. To obtain an output similar to that in Figure 3-5, adjust the controls as shown below. It is assumed that the controls are already set-up as described above for a Normal pulse; therefore only the alterations to these control settings will be given.

- a. Set the Mode switch (7) to EXT WIDTH.
- b. Apply an external trigger to the EXT INPUT (23). The input should have the following characteristics:
Pulse shape — sine or square wave
Amplitude — between 200mV and 6V
Frequency — 14kHz
- c. Set the EXT INPUT LEVEL (6) control as required to vary the switching threshold.
- d. Set the SLOPE/POLARITY switch as required to trigger off the rising (POS) or falling (NEG) edge of the trigger.

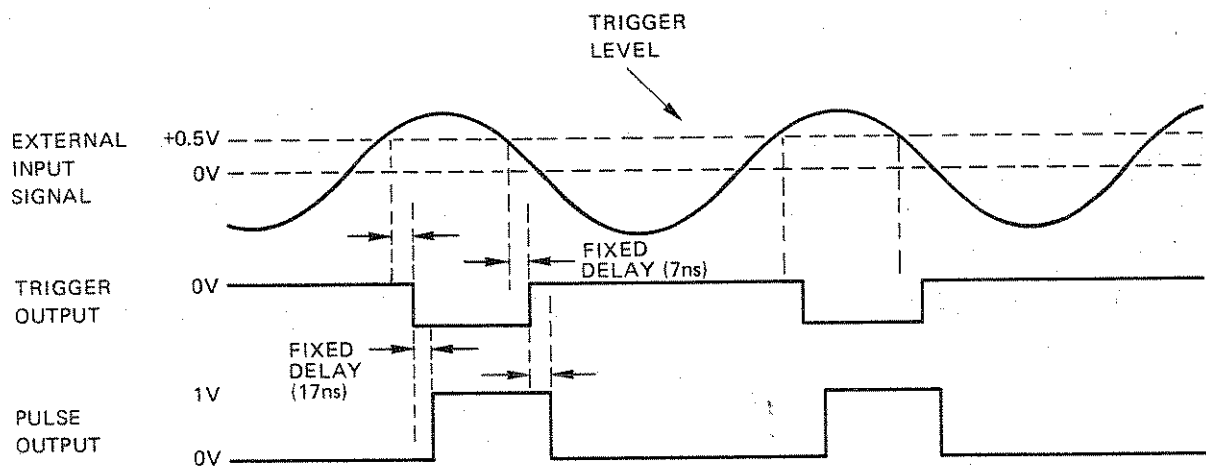

Figure 3-5. Pulse Output in External Width Mode

3-22 GATE OPERATING MODE

3-23 In Gate mode the repetition rate is defined by the rate controls but no output occurs until the voltage of an externally applied signal rises above (SLOPE/POLARITY switch set to POS) or falls below (SLOPE/POLARITY switch set to NEG) the level set on the EXT INPUT LEVEL control. The last pulse of a 'burst' is always of correct width even if the gate closes during

the pulse. To obtain an output similar to that in Figure 3-6, adjust the controls as shown below. It is assumed that the controls are already set-up as described above for a pulse in External Width mode; therefore only the alterations to these control settings will be given. Switching to External Width mode when in Gate mode can be used to check for correct functioning of the gate signal.

- a. Set the Mode switch ⑦ to GATE.

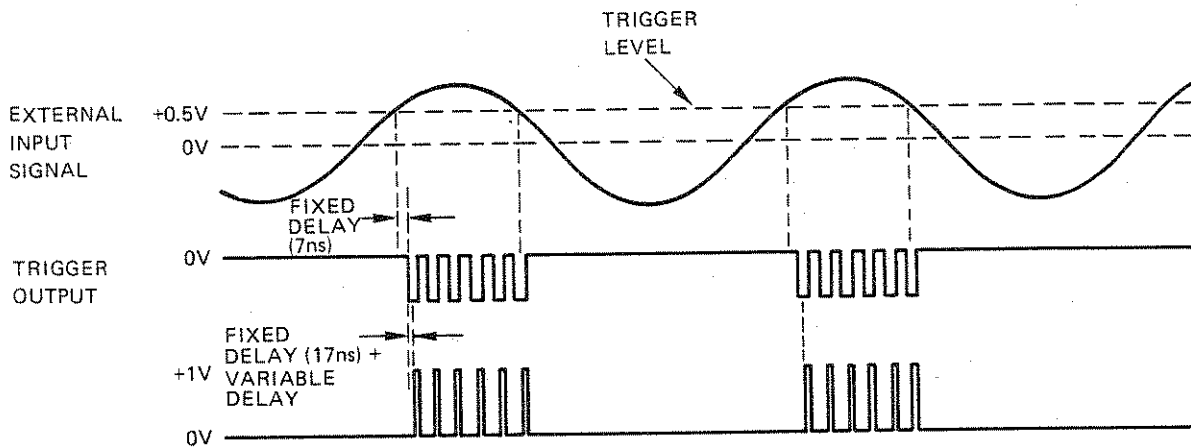

Figure 3-6. Pulse Output in Gate Mode

3-24 EXT TRIG OPERATING MODE

3-25 In External Trigger mode the pulse and trigger repetition rates are determined by the repetition rate of an externally applied signal. To obtain an output similar to that in Figure 3-7, adjust the controls as shown

below. It is assumed that the controls are already set-up as described above for a pulse in Gate mode; therefore only the alterations to these control settings will be given.

- a. Set the Mode switch ⑦ to EXT TRIG.

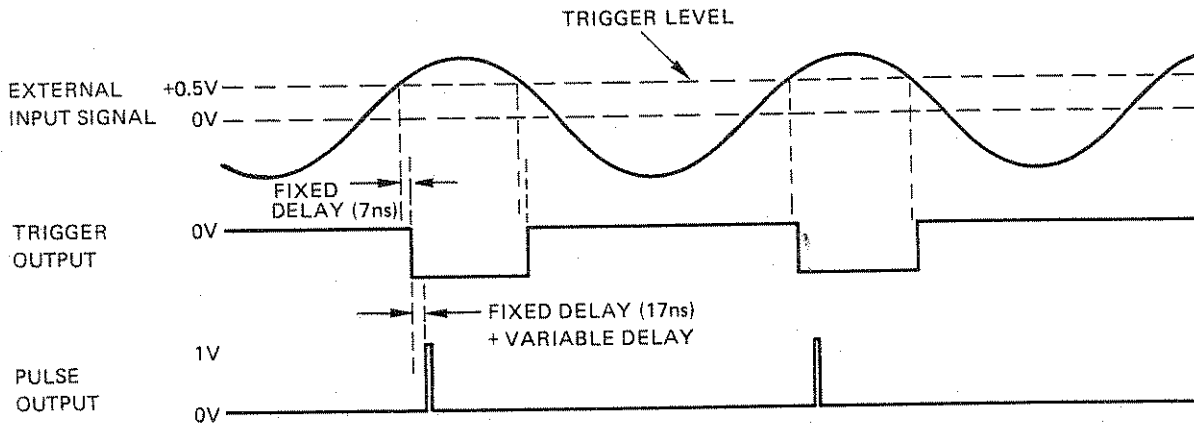

Figure 3-7. Pulse Output in External Trigger Mode

3-26 APPLICATIONS NOTES

3-27 The following section indicates some applications of the 8082A.

3-28 Digital Applications

3-29 The 8082A can be used to test the following digital integrated circuit (IC) logic families at their normal operating speeds:

	Propagation delay per gate
RTL	12ns - 27ns
DTL	30ns
TTL	12ns
Schottky TTL	3ns
ECL (including MECL III)	1ns - 4ns

For convenience of operation a special ECL output is available on the 8082A. This means that by simply setting either amplitude range switch to the ECL position, an output pulse with a voltage swing of $-0.9V$ to $-1.7V$ is produced into an open circuit.

When using the 8082A to test any of the above logic families, particularly the fast MECL III logic, it is important to operate with a 50 ohm transmission system. The coaxial cable does not need to be terminated at the IC and by a 50 ohm resistor; the internal 50 ohm termination of the 8082A is of sufficiently high quality to provide a clean pulse shape in almost all cases (see paragraph 3-31) without an external termination, even at the fastest transition times. This has the advantage that it enables the 50 ohm coaxial cable to be soldered directly to the pins of the IC under test without requiring a 50 ohm terminating resistor. It should be noted, however, that when no external termination is used, no connections can be made at any intermediate point along the transmission cable. For example, suppose the pulse on leaving the 8082A has 2V amplitude across an effective 25 ohms (50 ohm internal termination in parallel with 50 ohm cable); when the pulse reaches the IC its amplitude is doubled to 4V (open end reflection). This 4V is reflected back along the cable and is absorbed by the 50 ohm termination in the 8082A with only 2% typical reflection at amplitudes up to 4V. The effect of this action is to produce the stepped pulse shown in figure 3-8 at any intermediate point along the cable.

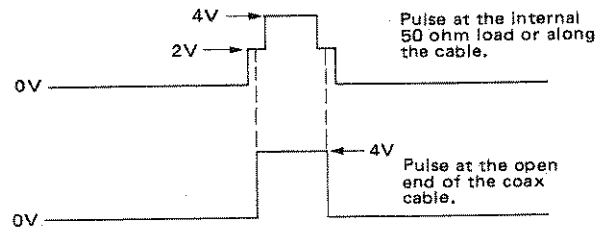

Figure 3-8. Stepped pulse with high-Z output

3-30 If a detailed analysis of IC waveshapes and timings is to be made, a 1 GHz sampling oscilloscope with a high impedance input probe should be used. The probe should be connected at the IC pin and not at any intermediate point along the 50 ohm cable.

3-31 If a number of IC's on one PC board are being driven from one point on the board and the printed circuit track is more than 10cm long, then an external 50 ohm resistor at the end of the 50 ohm system may be required to preserve the clean pulse shape at the IC input pins.

3-32 One point to remember, particularly when testing 1ns ECL, is the loss of edge speed due to the coaxial cable. However, the 8082A is fast enough to accommodate this edge speed degradation without exceeding the manufacturers specification. A 1.23 metre cable is available as HP Accessory number 10503A.

3-33 When testing flip-flops (Motorola MC1666 for example), two pulse generators are required, one to provide the clock input and one to provide the data input. One pulse generator is run in square wave mode and the other is run in external trigger and double pulse mode and is synchronized from the trigger output of the first pulse generator (Figure 3-9). Allowance must be made for the differential delay that will occur between the two outputs. This is caused by the fact that there is an extra 7ns delay in the second 8082A (24ns against 17ns) due to the delay between the trigger input and the trigger output. To preserve the correct timing relationship, therefore, between the two sets of pulse outputs, the data pulse output must be delayed by a further 7ns. This can be achieved by increasing the length of the data output transmission cable (delay is about 5ns per metre).

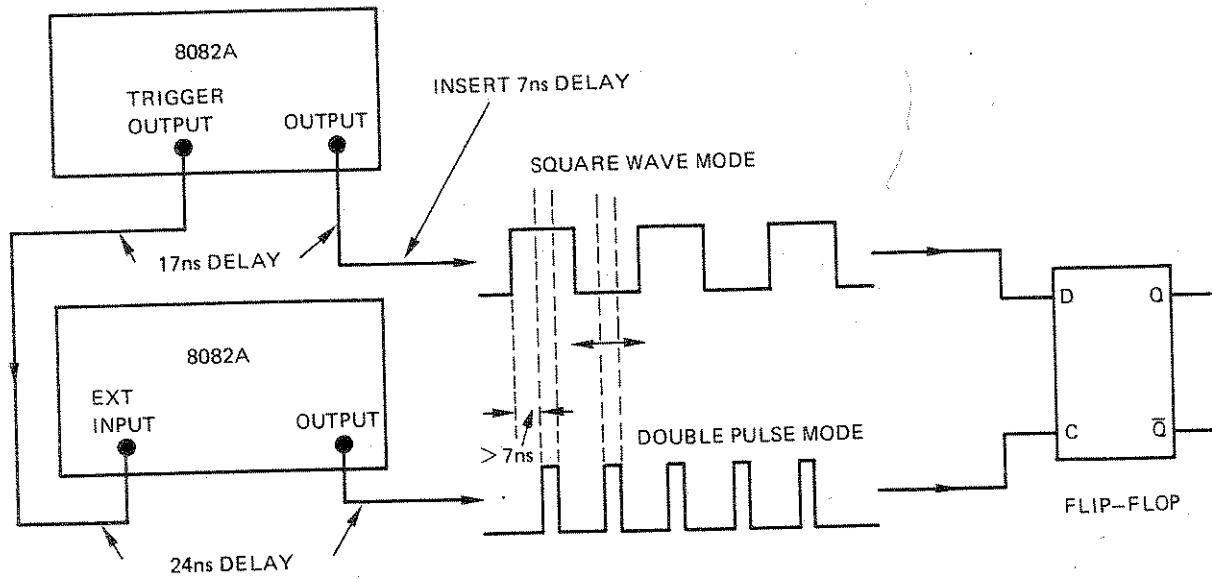

Figure 3-9. Flip-Flop Test Circuit

3-34 The minimum set-up time required for switching the flip-flop from '0' to '1' (or vice versa) can be measured as shown in Figure 3-10. The pulse delay controls of the clock output are slowly decreased and because the output is in double pulse form, only the second pulse in each case advances to-

wards the leading edge of its data input (in this case a '1'). The minimum set-up time is found when the flip-flop ceases to switch properly from '0' to '1'. The minimum set-up time for switching from '1' to '0' can then be found by switching to the complement of the data input and repeating the exercise.

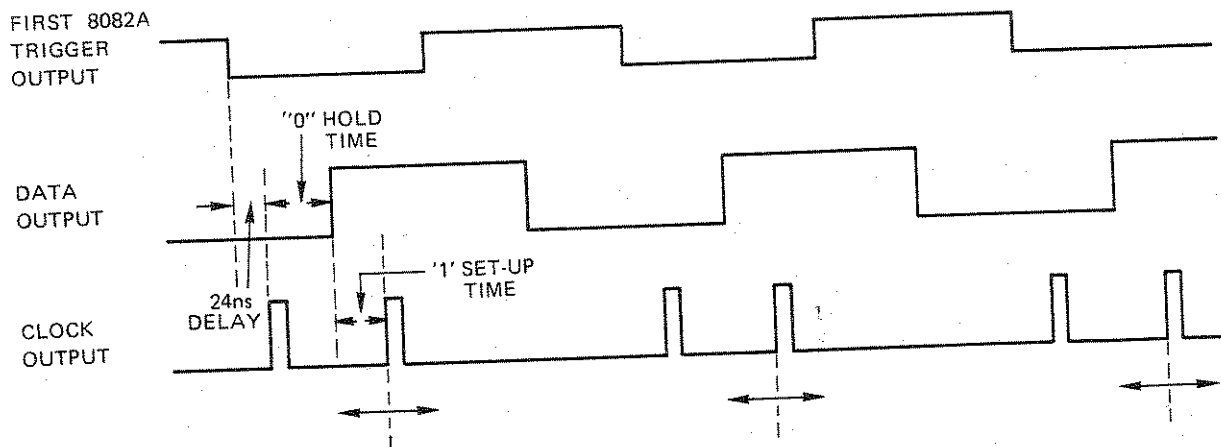

Figure 3-10. Flip-Flop Test Waveforms

3-35 The clock pulse transition times can be adjusted to observe the variation in the propagation delay of the flip-flop or to simulate edge degradation caused by a high fanout of the clock pulse line.

3-36 The 8082A can be used as a pulse shaper. When set to external width mode, an external signal (the output of a word generator for example) connected to the trigger input is available in pulse shaped form at the pulse output. Adjusting the trigger level control to the appropriate level helps to recover the shape of even badly distorted pulses.

3-37 The 8082A can also be used to generate noise pulses; the pulse width is set to minimum and the amplitude to 5V and then the transition times are increased. This has the effect of reducing the pulse amplitude and, in fact, the transition times can be increased until a spike of approximately 1ns width and 800mV amplitude (ECL amplitude) is produced (see Figure 3-11).

This can be set to the required dc level using the offset controls and connected to the logic circuit under

test to simulate noise. The amplitude and offset of the noise spike can be varied and their effect on the circuit monitored.

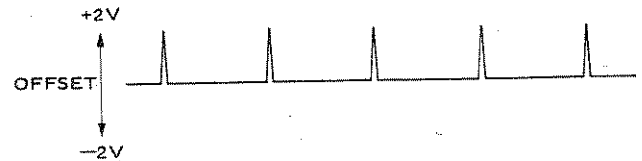

Figure 3-11. Noise Pulses

3-38 Analog Applications

3-39 The 8082A can also be used effectively in analog applications. Twisted pairs of transmission lines and differential amplifiers can be tested using the normal and complement outputs; the common amplitude vernier is very useful in this application for varying the amplitude of both outputs simultaneously. Trigger levels of Schmitt trigger circuits can be tested using output pulses with very slow transition times (as slow as 0.5ms).

Free Manuals Download Website

<http://myh66.com>

<http://usermanuals.us>

<http://www.somanuals.com>

<http://www.4manuals.cc>

<http://www.manual-lib.com>

<http://www.404manual.com>

<http://www.luxmanual.com>

<http://aubethermostatmanual.com>

Golf course search by state

<http://golfingnear.com>

Email search by domain

<http://emailbydomain.com>

Auto manuals search

<http://auto.somanuals.com>

TV manuals search

<http://tv.somanuals.com>