

Sophistication that you will appreciate.



The HP Digital Projector xp8020 is the perfect solution when a flexible and adaptable installed projector is needed to suit a variety of needs—be it for business, education or government. Designed for the most demanding digital projection needs, the HP Digital Projector xp8020 has a host of sophisticated features and state of the art management, security and networking capabilities to ensure optimum performance and minimum downtime.

Digital projection that suits all occasions

The HP Digital Projector xp8020 achieves vividly coloured and sharp images thanks to expert colour matching, enhanced colour tables, XGA resolution and a high contrast ratio (JBMA 1000:1), as well as from its innovative, switchable dual colour wheel projection technology that gives it the versatility of three separate digital projectors, via 3 operation modes:

- **Graphics mode:** A four-segment colour wheel provides bright and colourful graphics optimised for business presentation needs, with a brightness suitable for rooms with medium to bright ambient light levels.
- **Video mode:** A six-segment colour wheel delivers brilliant colour fidelity and rich colour saturation for excellent theatre video performance.
- **Greyscale mode:** Activating the greyscale mode disengages the colour wheels, producing 3100 peak ANSI lumens (maximum 4600 ANSI lumens), approximately 40% more brightness than it does in presentation mode, for superbly detailed black and white graphics detail.

3-position dual colour wheel projection technology for versatility

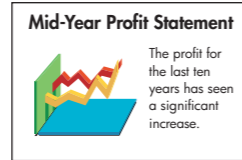

Graphic Mode: Bright and sharp presentation graphics



Greyscale Mode: Super bright monochrome images



Video Mode: Excellent theatre video performance



Access advance operation modes at a touch

Focus on the presentation.
Not the projector.

Easy to set up, easy to maintain

Designed for quick installation in a wide variety of environments (from offices to small or mid-size conference rooms), HP Digital Projector xp8020 features an advanced yet intuitive setup that makes presentations easy even for novice users. A wide variety of mounting options offers flexibility in placing the projector, and no matter where you place it, the top-loaded lamp is easily accessible for replacement, as needed.

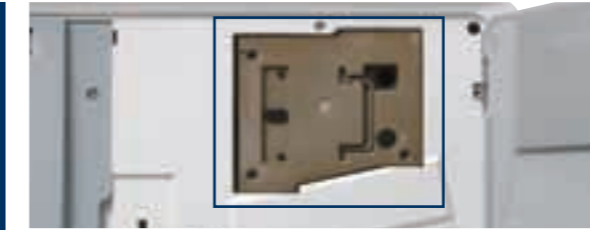

Top-accessed lamp housing for quick service call



Short, medium and long throw lenses (optional accessories)

Now every conference room is a theatre

Whatever your presentation is designed for—a small group, a team meeting in a conference room, or for multiple sites linked by a network—the HP Digital Projector xp8020 is the perfect tool for the job. It's short, medium and long-throw lenses (optional accessories) enable you to adjust the size of the projected image to suit the size of the presentation room.

You will also get to enjoy seamless presentations when using the HP Digital Projector xp8020. With its advanced electronic keystone correction, you will never need to stop in the middle of an important point to make awkward keystone corrections.

The audience hears you and not the projector

The whisper-quiet operation of the HP Digital Projector xp8020 means you can make your point without struggling to be heard over fan noise, and the integrated stereo 5-watt per channel speaker and chambered design make your message loud and clear to every member of the audience.

Real sophistication at your fingertips

The intuitive, laser-equipped remote control offers you ready access to all the projector's features—a refreshing change from the confusion and clutter of conventional remote controls. It is a projector that helps you focus on your presentation and your audience, not your equipment.

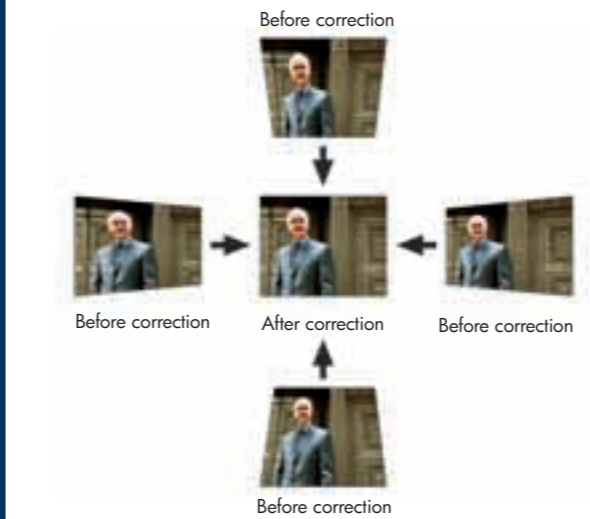

Advanced electronic keystone correction

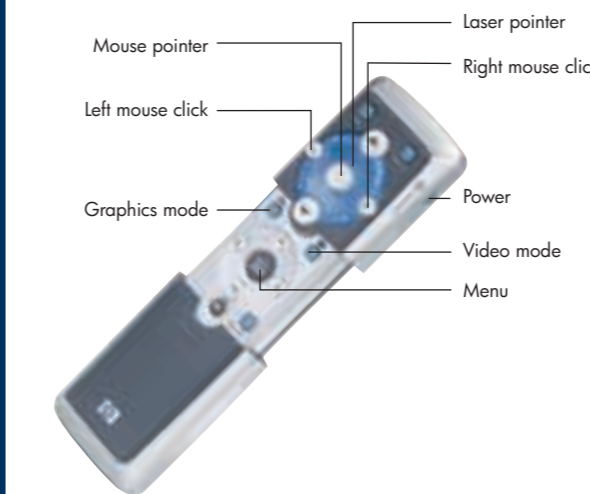

Presenter-centric remote for ease-of-use

No fuss. No worries.

Presenting wirelessly



Presentation without PC

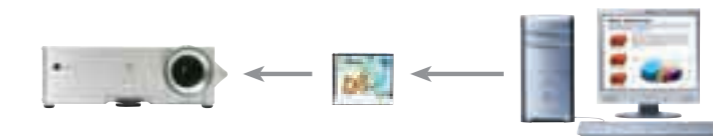

Enjoy presentations both wirelessly and without a PC



Networking made simple

Utilise the HP Digital Projector xp8020 with an optional wireless CompactFlash™ card, and you can access the projector directly from a wireless network, a PC or even a wireless enabled pocket PC. HP's wireless compression technology ensures instantaneous wireless connectivity, resulting in seamless, responsive control. You can even present directly from a CompactFlash™ memory card.

On a network, the HP Digital Projector xp8020 lets users drive network-based presentations, allowing presentations from almost anywhere and anyone. Collaborate with colleagues and clients on a network with the help of WebEx, NetMeeting or other web-based collaborative tools.

Remote asset management

Enjoy the convenience and lower cost of ownership by managing the projector's functions and maintenance remotely over the web. With HP's projector management software or standard SMTP—based tools, you can manage and control a network fleet of projectors. Functions like turning projectors on or off and changing of input can all be password-protected. This ensures that control of projectors is made available only to people you have designated to manage the projectors.

Guaranteed confidentiality and security

In addition to simplicity and convenience, the HP Digital Projector xp8020 also offers you absolute peace-of-mind with revolutionary built-in anti-theft devices. All your presentation materials and features on the HP Digital Projector xp8020 can be password-protected for extra security, which can be set over a web browser from a network, or via the optional remote asset management. Not only will the projector automatically alert you via email if it is removed from a network, but it also comes standard with a steel-backed Kensington lock slot.

An enhanced wireless security protocol will also ensure that your presentation data is protected and not compromised when you utilise its wireless capabilities.

Images—designed and engineered for you.

Everything you need to make a lasting impression

The HP Digital Projector xp8020 has been engineered to work with a wide spectrum of AV inputs and outputs—seven video inputs (each with dedicated & switched audio); full video and stereo-audio pass-through and integrated 5-watt per channel stereo sound.

State-of-the-art network capabilities and device connectivity

The HP Digital Projector xp8020 comes complete with a host of connectivity options for both computer peripherals as well as networks.

Advanced connectivity module

- RJ45 access to 10/100 network
- Browser-based interface for remote asset management
- RS232 for projector control
- Two USB ports (masters, as on a notebook)
- Two Type-II CompactFlash slots
- Wireless connectivity (available via CompactFlash™ Card)
- Memory (for presentation storage)

Enjoy incredible flexibility

The HP Digital Projector xp8020 comes with a wide array of optional accessories to make setting up presentations a breeze.

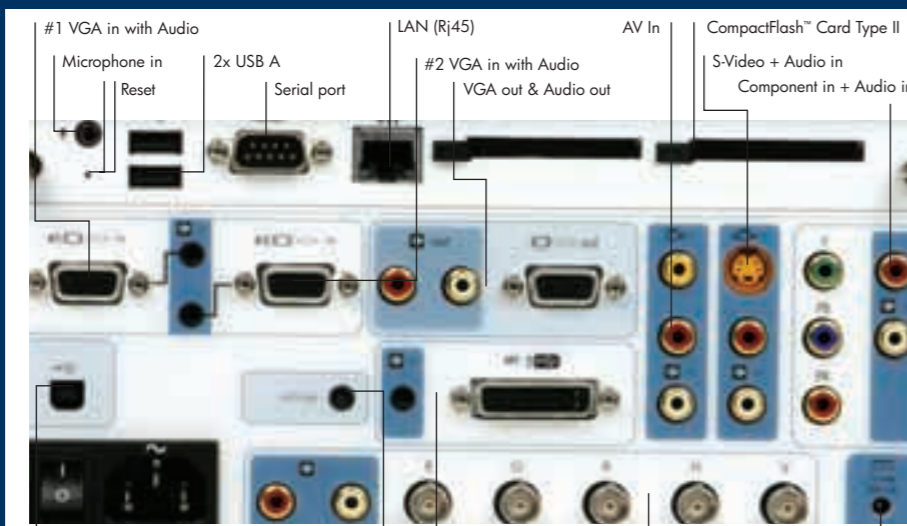

Multiple ports for all connectivity needs



Advance connectivity module



USB cable Scart/USB cable

Optional accessories

Images shown is only a representation. Actual products may differ slightly.



Mobile screen

Technical specifications

Model	HP Digital Projector xp8020
Part number	L1576A
Brightness	3100 peak ANSI lumens; 4600 greyscale-mode lumens
Resolution	Native XGA (1024 x 768); Scaled VGA through UXGA (640 x 350 through 1600 x 1200); HDTV and Mac compatible; NTSC, PAL and SECAM compatible
Contrast ratio	JBMA 1000:1 (full on/full off)
Projection	F/2.0 ~ 2.4, f=28.6 ~ 34.3 mm with 1.2x manual zoom lens
Weight	6.1 kg (13.4 lb)
Light valve technology	Texas Instruments Digital Light Processing™ (DLP™): 0.7 inches 12" DDR
Size	400 x 275 x 130 mm (15.8 inches x 10.8 inches x 5.1 inches) without handle, focus ring, feet; 442 x 304 x 139 mm (17.4 inches x 12.0 inches x 5.5 inches) with handle, focus ring, feet
Video/audio connector (paired and switched)	M1-DA/mini phone plug; VGA input 1/mini phone plug; VGA input 2/mini phone plug; VGA output/stereo RCA; S-video input/stereo RCA; Composite video input/stereo RCA; Component video input—3 RCA (YPbPr)/stereo RCA; BNC (RGsB, RGBS, RGBHV or YPbPr)/stereo RCA
I/O connectors	USB controllers (2 Type A) for use with optional mouse or keyboard; USB device (Type B) for connecting to a mouse to a PC or notebook; LAN (RJ45); CompactFlash card slots for wireless networking, memory; RS232 (9 D-sub); switched 12v power control (barrel); wired remote (mini phone); IRremote front and rear
IR	Front and rear
Cable shroud	Yes
Lens	Digital zoom; Optical zoom 1.2:1; Standard 2.0:1 ~ 2.4:1; Accessories Lenses (bayonet mount): Short-throw 1.67:1 ~ 2.0:1, Long-throw 2.1:1 ~ 2.88:1
Keystone correction	Horizontal ±15° (30° total); Vertical ±16° (30° total)
Colour wheel	3-position dual colour wheel with auto positioning: presentation graphics, super bright (grayscale), theatre video
Lamp	300-watt P-VIP Lamp (L1582A); 2000-hour life; 4000-hour life in lamp-saver mode
Video compatibility	S-video, composite, component, HDTV (up to 1080i)
Computer compatibility	UXGA, SXGA, XGA+, XGA, SVGA, VGA, Mac, Mac LC 13 inches, MAC II 13 inches, MAC 16 inches, MAC 19 inches, MAC G4, i Mac DV
Power	100-120 V, 200-240 V at 50-60 Hz; Battery backup for time/date
IR remote control	Integrated USB mouse with laser pointer; supports wired and long-range wireless option (L1642A)
Audio	5-watt stereo with acoustic chambers
Mounting	Ceiling, table top
Security	Kensington™ locks; Theft alert
Noise level	32 dBA
Accessory level	L1583A 300-watt P-VIP lamp (1.3 mm)
Optional accessories	Cable VGA/USB to M1-A 1.8 m; Cable M1 to DVI/USB 1.8 m; Lens ultra wide angle 1.67:1 to 2.0:1; Lens long throw 2.4:1 to 2.88:1; Lamp module, 300-watt P-VIP; Cable M1-to-SCART 1.8 m; Cable M1-to-BNC 1.8 m; Ceiling mount kit; 802.11b
Three-year warranty	Hewlett-Packard (HP) warrants to the end-user customer that the HP Digital Projector xp8020 will be free from defects in materials and workmanship for 3 years, which duration begins on the date of purchase by the customer. Customer is responsible for maintaining proof of date of purchase. The lamp module is warranted for 90 days or 500 hours (whichever comes first). See the full Limited Warranty Statement for complete details.
What's in the box	HP Digital Projector xp8020, AC 3 conductor power cord (3 m) (10 ft), VGA cable, wireless remote control with mouse function and laser pointer, multi-language User's Guide (CD-ROM), multi-language Quick Start Card, 2 batteries (include manufacturer and address information), hanging lens cap, warranty card

For more information, call your local Hewlett-Packard sales office or your nearest HP authorised dealer:

HP customer information centre (for product information)	
Australia	132347
China	+86 21 2898 2255
Hong Kong	+852 800 938 833
India	+9628 123 123 (Del/Mum/Blr)
	+1600 444 999 (other cities)
Indonesia	+0800 1111 222
Korea	+080 703 0700
Malaysia	+1800 88 4848
New Zealand	+0800 733 547
Philippines	+1800 1331 4488
Singapore	+1800 278 8100
Taiwan	+0800 236 686
Thailand	+662 353 9000
Vietnam	+848 823 6215

For the following countries, please fax your queries to: +65 6 275 6707
• Bangladesh • Brunei • Cambodia • Pakistan • Sri Lanka

HP customer care centre (for post-sales service)	
Australia	+61 3 8877 8000
China	+86 10 6868 7980
Hong Kong	+852 800 96 7729
India	+91 11 682 6035
Indonesia	+62 21 350 3408
Korea	+82 2 3270 0700
Malaysia	+60 3 2695 2566
New Zealand	+64 9 356 6640
Philippines	+63 2 867 3551
Singapore	+65 6 272 5300
Taiwan	+886 2 8722 8000
Thailand	+662 353 9000
Vietnam	+848 823 4530

For more information on HP Care Pack, visit www.hp.com/apac/hpservices/carepack
HP Instant Support Professional Edition (ISPE), visit: <http://instant.support.asiapac.hp.com>

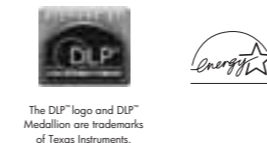

The DLP™ logo and DLP™ Modulation are trademarks of Texas Instruments.

© 2004 Hewlett-Packard Development Company, L.P.
The information contained herein is subject to change without notice. The only warranties for HP products and services are set forth in the express warranty statements accompanying such products and services. Nothing herein should be construed as constituting an additional warranty. HP shall not be liable for technical or editorial errors or omissions contained herein.

Printed in Singapore, 2001-1363-EFP, 05/2004 (Rev 1)

Ordering information

Accessories	
L1578A	Lens ultra wide 1.67:1 to 2.0:1
L1580A	Lens long throw 2.4:1 to 2.88:1
L1581A	Advance connectivity module
L1583A	300-watt comp P-VIP projector lamp (xp8020)
L1584A	Soft carry case
L1585A	Hard carry case
L1586A	Remote control, wireless (IR) Smart (included)
L1590A	Ceiling mount
L1640A	R802.11b CompactFlash wireless card
L1642A	Cable extended IR receiver
L1645A	Gyration Ultra Pro Suite
L1646A	Gyration RF remote control
L1682A	Remote Access management software
Cables	
L1514A	Cable, VGA/USB to M1-DA, 6ft
L1529A	Cable, M1-DA to DVI/USB, 6ft
L1588A	Cable, M1-DA to SCART, 6ft
L1589A	Cable, M1-DA to BNC, 6ft



HP Digital Projector xp8020

Sophistication that you will appreciate



Free Manuals Download Website

<http://myh66.com>

<http://usermanuals.us>

<http://www.somanuals.com>

<http://www.4manuals.cc>

<http://www.manual-lib.com>

<http://www.404manual.com>

<http://www.luxmanual.com>

<http://aubethermostatmanual.com>

Golf course search by state

<http://golfingnear.com>

Email search by domain

<http://emailbydomain.com>

Auto manuals search

<http://auto.somanuals.com>

TV manuals search

<http://tv.somanuals.com>