

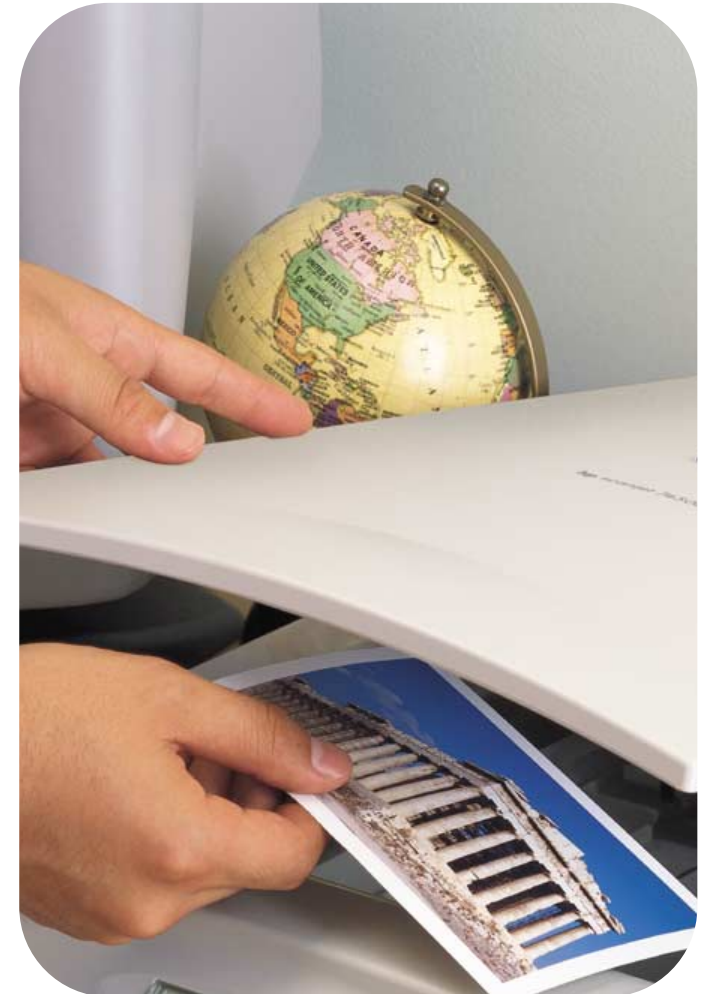

**hp** scanjet 4400c series  
and 5400c series scanners  
user's manual



### *Copyright information*

© Copyright Hewlett-Packard Company 2001

All rights reserved. Reproduction, adaptation, or translation without prior written permission is prohibited, except as allowed under copyright laws.

### *Trademark credits*

Microsoft ®, Windows ®, Windows NT ®, Hotmail ®, Microsoft Word ®, Microsoft Outlook ®, and Outlook Express ® are U.S. registered trademarks of Microsoft Corporation. Adobe™ and Acrobat™ are trademarks of Adobe Systems Incorporated. Netscape ® is a U.S. registered product of Netscape. Energy Star ® is a U.S. registered service mark of the United States Environmental Protection Agency.

All other products mentioned herein might be trademarks of their respective companies.

### *Warranty*

The information contained in this document is subject to change without notice.

Hewlett-Packard makes no warranty of any kind with respect to this information. HEWLETT-PACKARD SPECIFICALLY DISCLAIMS THE IMPLIED WARRANTY OF MERCHANTABILITY AND FITNESS FOR A PARTICULAR PURPOSE.

Hewlett-Packard shall not be liable for any direct, indirect, incidental, consequential, or other damage alleged in connection with the furnishing or use of this information.

**NOTICE TO U.S. GOVERNMENT USERS: RESTRICTED RIGHTS COMMERCIAL COMPUTER SOFTWARE:** "Use, duplication, or disclosure by the Government is subject to restrictions as set forth in subparagraph (c) (1) (ii) of the Rights in Technical Data Clause at DFARS 52.227-7013."

Material scanned by this product might be protected by governmental laws and other regulations, such as copyright laws. The customer is solely responsible for complying with all such laws and regulations.







# Front panel and accessories comparisons

The following tables provide information about the HP Scanjet 4400c series and 5400c series scanners, including descriptions of the buttons available on the front panels and the accessories you can use with these scanners.

To find information about your scanner, see the following tables:

- ["HP Scanjet 4400c scanner" on page 4.](#)
- ["HP Scanjet 4470c scanner" on page 5.](#)
- ["HP Scanjet 5400c scanner" on page 6.](#)
- ["HP Scanjet 5470c scanner" on page 7.](#)
- ["HP Scanjet 5490c scanner" on page 9.](#)





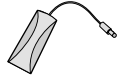

# HP Scanjet 4400c scanner





Feature	Included on scanner or in box	Supported accessory <sup>a</sup>
Copy button 	✓	
Photo Reprint button 	✓	
Scan To button 	✓	
E-mail button 	✓	
Power Save button 	✓	
USB cable 	✓	
Parallel cable 		✓

Feature	Included on scanner or in box	Supported accessory <sup>a</sup>
HP Scanjet Transparency Adapter (XPA) 		✓

a. Supported accessories include accessories that are not boxed with the scanner, but can be purchased separately.







## HP Scanjet 4470c scanner

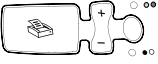

Feature	Included on scanner or in box	Supported accessory <sup>a</sup>
Copy button 	✓	
Color/black & white copy button and select number of copies buttons 	✓	
Photo Reprint button 	✓	
Scan To button 	✓	
E-mail button 	✓	
Share-to-Web button 	✓	
Power Save button 	✓	

Feature	Included on scanner or in box	Supported accessory <sup>a</sup>
More options button 	✓	
Cancel button 	✓	
Two-digit LCD	✓	
USB cable 	✓	
Parallel cable 		✓
HP Scanjet Transparency Adapter (XPA) 	✓	

a. Supported accessories include accessories that are not boxed with the scanner, but can be purchased separately.



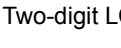
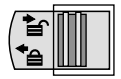
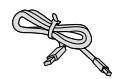

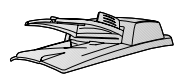

## HP Scanjet 5400c scanner



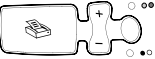



Feature	Included on scanner or in box	Supported accessory <sup>a</sup>
Copy button 	✓	
Color/black & white copy button and select number of copies buttons 	✓	
Photo Reprint button 	✓	
Scan To button 	✓	
E-mail button 	✓	
Share-to-Web button 	✓	
Power Save button 	✓	
More options button 	✓	

Feature	Included on scanner or in box	Supported accessory <sup>a</sup>
Cancel button 	✓	
Two-digit LCD 	✓	
Scanner lock 	✓	
USB cable 	✓	
Parallel cable 	✓	
HP Scanjet Transparency Adapter (XPA) 		✓
HP Scanjet Automatic Document Feeder (ADF) 		✓

a. Supported accessories include accessories that are not boxed with the scanner, but can be purchased separately.

## HP Scanjet 5470c scanner

Feature	Included on scanner or in box	Supported accessory <sup>a</sup>
Copy button 	✓	
Color/black & white copy button and select number of copies buttons 	✓	
Photo Reprint button 	✓	
Scan To button 	✓	
Select Destination button 	✓	
E-mail button 	✓	
Share-to-Web button 	✓	



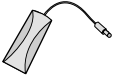
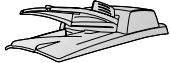



Feature	Included on scanner or in box	Supported accessory <sup>a</sup>
Power Save button 	✓	
More options button 	✓	
Cancel button 	✓	
16-character LCD	✓	
Scanner lock 	✓	
USB cable 	✓	
Parallel cable 	✓	



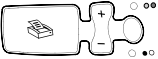



Feature	Included on scanner or in box	Supported accessory <sup>a</sup>
HP Scanjet Transparency Adapter (XPA) 	✓	
HP Scanjet Automatic Document Feeder (ADF) 		✓



- a. Supported accessories include accessories that are not boxed with the scanner, but can be purchased separately.



## HP Scanjet 5490c scanner

Feature	Included on scanner or in box	Supported accessory <sup>a</sup>
Copy button 	✓	
Color/black & white copy button and select number of copies buttons 	✓	
Photo Reprint button 	✓	
Scan To button 	✓	
Select Destination button 	✓	
E-mail button 	✓	
Share-to-Web button 	✓	

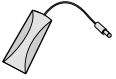
Feature	Included on scanner or in box	Supported accessory <sup>a</sup>
Power Save button 	✓	
More options button 	✓	
Cancel button 	✓	
16-character LCD	✓	
Scanner lock 	✓	
USB cable 	✓	
Parallel cable 	✓	

Feature	Included on scanner or in box	Supported accessory <sup>a</sup>
HP Scanjet Transparency Adapter (XPA) 	✓	
HP Scanjet Automatic Document Feeder (ADF) 	✓	

- a. Supported accessories include accessories that are not boxed with the scanner, but can be purchased separately.

# Contents

## Front panel and accessories comparisons

HP Scanjet 4400c scanner . . . . .	4
HP Scanjet 4470c scanner . . . . .	5
HP Scanjet 5400c scanner . . . . .	6
HP Scanjet 5470c scanner . . . . .	7
HP Scanjet 5490c scanner . . . . .	9

## 1 Getting started

Printing this information . . . . .	13
Viewing the product tour . . . . .	13
Where do I start? . . . . .	14
Using the scanner buttons . . . . .	14
Using the HP Precisionscan Pro software . . . . .	14
Using another program . . . . .	14
Using the HP Scanjet Copy Utility . . . . .	14
Selecting and preparing items . . . . .	15
Items for the scanner glass . . . . .	15
Items for the ADF . . . . .	16
Items for the XPA . . . . .	16
Completing your first scan . . . . .	17
Frequently asked questions . . . . .	20

## 2 Scanning from scanner buttons

Overview of scanner buttons . . . . .	24
Scanning quickly with scanner buttons . . . . .	26
Scanning to the HP Precisionscan Pro software . . . . .	26
Scanning to another program . . . . .	27
Sending a scan to a website . . . . .	28
Scanning for photo reprints . . . . .	29
Sending a scan using e-mail . . . . .	30
Printing copies . . . . .	33

Changing settings for buttons . . . . .	34
List of options for scanner buttons . . . . .	35

## 3 Scanning from HP Precisionscan Pro

Overview of the HP Precisionscan Pro software . . . . .	39
Starting the HP Precisionscan Pro software . . . . .	40
Finding help for using the software . . . . .	40
Performing a new scan . . . . .	41
Cropping or selecting an area for final scan . . . . .	42
Getting a closer look (zooming) . . . . .	43
Selecting output type . . . . .	43
Making optional adjustments, basic . . . . .	45
Resizing (output dimensions) . . . . .	45
Changing resolution . . . . .	46
Changing contrast . . . . .	46
Rotating an image . . . . .	47
Mirroring (reversing) an image . . . . .	47
Sharpening an image . . . . .	48
Resetting all adjustments . . . . .	48
Making optional adjustments, advanced . . . . .	49
Inverting the image . . . . .	49
Changing midtones . . . . .	50
Changing highlights . . . . .	51
Changing shadows . . . . .	52
Checking for clipped areas . . . . .	53
Setting pixel output levels . . . . .	54
Viewing RGB values and pixels . . . . .	55
About the histogram . . . . .	56
Changing the hue . . . . .	56
Changing the saturation . . . . .	57
Changing the black and white threshold . . . . .	58

Setting which colors become black or white in black & white bitmaps . . . . .	59
Descreening images . . . . .	60
Resetting all adjustments . . . . .	60
Completing the final scan. . . . .	61
Sending to a program . . . . .	61
Returning the image to a TWAIN program . . . . .	62
Saving to a file . . . . .	62
Printing . . . . .	64
Placing a scan on a website . . . . .	64
Setting the scanned image as wallpaper . . . . .	65
Copying and pasting into another program . . . . .	65
Dragging-and-dropping into another program . . . . .	65
Dragging-and-dropping to the Windows Desktop or a folder . . . . .	66
Scanning to CD . . . . .	66
Other features and tips . . . . .	67
Tips for best image quality . . . . .	67
Saving settings . . . . .	68
Setting preferences . . . . .	68
Scanning from other programs (TWAIN) . . . . .	71
Scanning from other programs (WIA) . . . . .	72
What to expect from OCR programs . . . . .	73

## 4 Using accessories

Scanning from the ADF . . . . .	76
Scanning from the XPA . . . . .	77
Scanning slides . . . . .	77
Scanning negatives . . . . .	79
Making optional adjustments for slides or negatives. . . . .	81
Adjusting midtones for slides or negatives. . . . .	81
Adjusting highlights for slides or negatives . . . . .	82
Adjusting shadows for slides or negatives . . . . .	82
Viewing RGB values and pixel color . . . . .	83

## 5 Troubleshooting and maintaining

Checking the basics . . . . .	85
Starting troubleshooting . . . . .	86
Resolving scanner messages. . . . .	87
Resolving issues that did not generate messages. . . . .	87
Resolving image-quality issues. . . . .	90
Resolving issues with scanned images. . . . .	91
Resolving issues with printed copies . . . . .	93
Resolving issues with slides and negatives . . . . .	95
Resolving issues with editable text . . . . .	96
Resolving issues sending to destinations . . . . .	97
Resolving issues with accessories. . . . .	100
Resolving issues with the XPA. . . . .	100
Resolving issues with the ADF . . . . .	101
Clearing jams from the ADF . . . . .	102
Cleaning and maintaining . . . . .	105
Cleaning the scanner glass. . . . .	105
Cleaning the XPA . . . . .	106
Cleaning the ADF glass . . . . .	106
Uninstalling the software . . . . .	107
Other resources, support, and specifications . . . . .	107

## A Using software commands and controls

Using keyboard shortcuts and the menus. . . . .	110
HP Precisionscan Pro tool and information bars . . . . .	113
Toolbar . . . . .	113
Adding tools to the toolbar . . . . .	114
Info bar. . . . .	114
Status bar . . . . .	115
Context-sensitive cursors. . . . .	116

## B Glossary

## Index

# 1 Getting started

This section contains the basics to help you get started with your new HP Scanjet scanner. From here, you can learn about viewing the product tour, preparing items before you scan them, and choosing which scanning method to use.

## Printing this information

To print this .pdf manual, use the **Print** command on the **File** menu. Print the whole document, or print only the chapters or topics you want according to their page numbers. See the table of contents for page numbers of topics.

## Viewing the product tour

The product tour is a fast and easy way to explore the capabilities of the scanner and see some interesting ways you can use the scanner to meet your needs. The product tour, which only takes three minutes, begins automatically when you start the HP Precisionscan Pro software. However, you also have the option of disabling the product tour and viewing it at another time.

To view the tour at other times: On the **Start** menu, point to **Programs**, and click **HP Precisionscan Pro**. Then, on the **Help** menu, click **Product Tour**.

## Where do I start?

You can start scanning from one of these places:

- Scanner buttons
- HP Precisionscan Pro software
- Another program
- HP Scanjet Copy Utility

Where you start depends on what you want to do with the scan and on your own preferences.

### Using the scanner buttons

Use the scanner buttons, which are shortcuts, when you want to:

- start at the scanner.
- scan quickly without making changes.
- scan an item using the default settings optimized for the destination you choose.

See ["Scanning from scanner buttons" on page 23](#).

### Using the HP Precisionscan Pro software

Use the HP Precisionscan Pro software when you want to:

- view or change a scanned image before you send it. Changes might include resolution, cropping, or resizing.
- send to a destination, such as a desktop publishing program, but there is no button on the scanner for that destination.

See ["Scanning from HP Precisionscan Pro" on page 39](#).

## Using another program

Start scanning from within another program when:

- You want to bring a scanned item into an open program, such as your word-processing program.
- The program in which you are working is compliant with TWAIN or WIA. A program is compliant if a command such as **Acquire Image** or **From Scanner** appears on a menu such as the **File** menu. If you are unsure whether your program complies with TWAIN or WIA standards, or you do not know the command for inserting a scanned item, see the documentation for the program.

See ["Scanning from other programs \(TWAIN\)" on page 71](#).

If the program is compliant with WIA, see ["Scanning from other programs \(WIA\)" on page 72](#).

## Using the HP Scanjet Copy Utility

Use the HP Scanjet Copy Utility when you need to make standard copy adjustments, such as reducing or enlarging, or lightening or darkening. You can also choose a printer other than the default.

To start the utility: on the **Start** menu, point to **Programs**, point to **HP Scanjet Utilities**, and click **HP Copy Utility**. For help using the utility, click **Help** in the utility.

## Selecting and preparing items

Before placing items in the scanner, follow these guidelines for selecting and preparing them to prevent damage to the items and the scanner.

**CAUTION** Improper placement and scanning can damage the items and the scanner.

### Items for the scanner glass

The scanner glass can scan the widest range of items, including:

- paper items
- news clippings, receipts, and business cards
- items on all weights of media, including media lighter than 60 g/m<sup>2</sup> (16 lb) or heavier than 105 g/m<sup>2</sup> (28 lb)
- gum-backed paper
- multipart forms with carbon pages
- old or worn photographs or documents
- items containing tears, perforations, punch holes, wrinkles, or curls
- flatter three-dimensional items such as fabric, pages in books, and paper with texture

**CAUTION** Avoid placing items with sharp edges on the scanner glass. Doing so can damage the scanner.

Before placing an item on the scanner glass, make sure the item is free of wet glue, correction fluid, or other contaminating substances.

## Items for the ADF

The HP Scanjet Automatic Document Feeder (ADF), which is a fast, convenient way to scan multiple-page items, is included or supported on some scanner models. See ["Front panel and accessories comparisons" on page 3](#). The ADF accepts items that meet the following specifications:

- items on standard Letter-, A4-, and Legal-size media
- items consisting of as many as 25 unbound pages
- items ranging in size from 88.9 by 127 mm (3.5 by 5 inches) to 215.9 by 355.6 mm (8.5 by 14 inches)
- items ranging in weight from 60 to 90 g/m<sup>2</sup> (16 to 24 lb)
- items that are square or rectangular and in good condition (not fragile or worn)
- items that are free of tears, perforations, or punch holes
- items that are free of wet glue, correction fluid, or ink

Avoid multipart forms with carbon pages, transparencies, magazine pages, gum-backed pages, and light "onionskin" pages.

Before placing an item in the ADF, prepare the item by doing the following:

- Remove curls or wrinkles.
- Remove staples, paper clips, paper sticky notes, and any other materials from items.

If your item does not meet these guidelines or you cannot prepare it as stated, use the scanner glass.

## Items for the XPA

The HP Scanjet Transparency Adapter (XPA) is included with some scanner models or can be ordered. Use the XPA and its templates to scan:

- 35 mm photographic negatives
- 35 mm slides

Because these items are easily damaged, handle them only by their edges.



## Completing your first scan

This section shows you how to take the same item and scan to print using the two primary scanning methods:

- Scanner buttons
- HP Precisionscan Pro software

Before scanning, place the item in the scanner.

### *To load the item in the scanner*

- 1 Choose an item to scan, such as a page from a magazine.

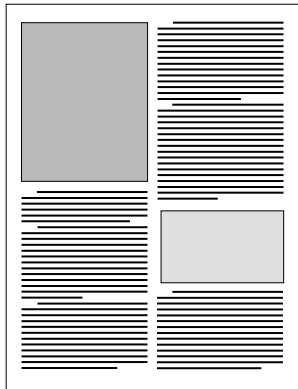

- 2 Place the item face down on the scanner glass and close the lid.

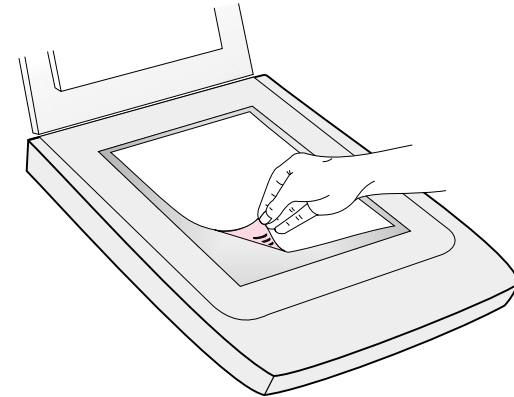

- 3 See "[To complete your first scan using the scanner buttons](#)" on [page 18](#).

*To complete your first scan using the scanner buttons*

- 1 Load the item in the scanner. See ["To load the item in the scanner" on page 17.](#)
- 2 On the scanner, press the Copy button (  ). The scanner scans the item using settings optimized for printing this type of item and then prints the item to the default printer.

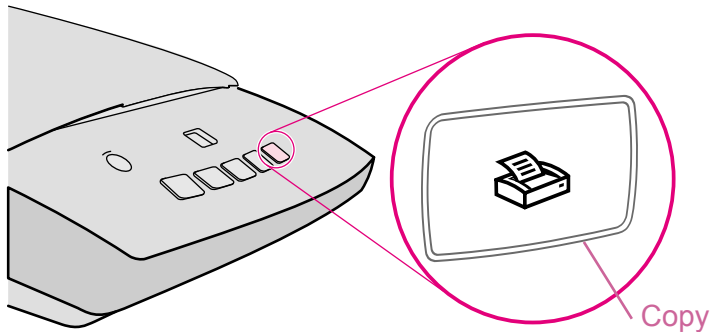

- 3 If the scan does not work, or you have difficulty with this process, please see ["Resolving issues that did not generate messages" on page 87.](#)

If you have not already scanned using the HP Precisionscan Pro software, see ["To complete your first scan using the HP Precisionscan Pro software" on page 18.](#)

*To complete your first scan using the HP Precisionscan Pro software*

- 1 Load the item in the scanner. See ["To load the item in the scanner" on page 17.](#)
- 2 With the item loaded, press the Scan To button (  ) on the scanner. The scanner scans the item to the HP Precisionscan Pro software, choosing the best settings for this type of item.
- 3 When the scanned image appears in the preview window of the software, draw a selection border around the image or the portion of the image you want. To do so, click on one corner of the area you want, and while holding down the mouse button, drag the cursor to the opposite corner. Release the mouse button to complete the border.



- 4 Experiment with the image. Change the output type or make other adjustments.
- 5 When you finish: On the **Scan** menu, click **Print**.
- 6 Select any printer options you want and click **OK**. The scanner performs a final scan including your changes, then prints the scanned image.
- 7 If the scan does not work, or you have difficulty with this process, please see ["Resolving issues that did not generate messages" on page 87](#).

If you have not already scanned using the scanner buttons, see ["To complete your first scan using the scanner buttons" on page 18](#).

## Frequently asked questions

This section contains answers to some questions users frequently ask about scanning.

### *What settings does the HP Precisionscan Pro software set automatically for an item I scan?*

Based on the scanned item, the software automatically chooses optimal values for these settings:

- output type
- resolution
- sharpening
- exposure (midtones, highlights, and shadows)
- color (hue and saturation or black & white threshold)

Usually, the values the software selects provide optimal results. However, you can change these values in the HP Precisionscan Pro software.

### *How can I reduce the time it takes to scan?*

You can reduce the time it takes to scan an item by scanning in black and white when the original is one of the following:

- a black-and-white photograph or drawing
- a color photo or drawing, but you want a black-and-white image to appear on the computer screen
- contains only text

Another option is to reduce file size. See "[How can I reduce the file size?](#)" on page 21.

Print color originals as black and white by selecting the Black & White option on the front panel and pressing the Copy button . Or, in the HP Precisionscan Pro software, choose the **Grayscale** or **Black & White** output types before your final scan (after the scanner completes a preview scan). See "[Selecting output type](#)" on page 43.

In the HP Precisionscan Pro software, select the **Extend lamp time out** setting on the **Scanner** tab. When selected, this setting keeps the scanner lamp and the XPA light source (if connected) on beyond the default time out period. See "[Setting preferences](#)" on page 68.

### *How can I reduce the file size?*

To reduce file size:

- Save files using a compressed format, such as TIFF compressed or JPEG.
- Avoid using the True Color output type unless necessary. This output type offers exceptional quality for color photos or drawings, but it also creates large file sizes.
- Set the resolution no higher than necessary. Generally, the resolution the software automatically sets provides the best balance between image quality and small file size.
- For photos, significantly reduce file size by cropping the photo to select just one area as the final scanned image. Or, resize the entire photo to smaller dimensions.

### *Should I change the resolution?*

The HP Precisionscan Pro software sets the resolution for you based on the original document attributes. In almost all cases, you get the best results and the smallest file size using the default resolution.

### *What is the difference between screen and print quality?*

A computer screen usually displays images at 72 to 75 pixels per inch (PPI). Print resolution is usually higher. Screens also use fewer colors to display an image. Even if an image looks incorrect on the screen, it might print the way you want.

### *What is the difference between zooming and resizing?*

Use **Zoom In** to view an area of the scanned image close up. Use **Zoom Out** to return to the original view of the image.

The zoom commands do not change the final size of your scan; they just give you a different view on a monitor. To reduce or enlarge the size of the final scan, use the **Resize** command on the **Tools** menu.

### *What do I need to know about scanning text?*

When you scan an item containing text, you can use the text either as a scanned image, such as a fax or image archive, or as text you can edit.

To have the optical character recognition (OCR) software make the text editable automatically and send the text to a supported word-processing program, press the Scan To button (  ). In the HP Precisionscan Pro software, use the output type of **Editable Text (OCR)** or **Text & Image**. Then, on the **Scan** menu, click **Scan To**, choose your word-processing program, and click **Scan**.

---

**Tip** Perform a spell-check after you have successfully scanned your text to a word-processing program.

---



# 2 Scanning from scanner buttons

The scanner buttons provide an easy way to scan items directly to destinations using settings optimized for the destination you choose. You do not view or change scanned images before they go to the destination.

To view or change images, scan to the HP Precisionscan Pro software using the Scan To button (  ). For more help viewing or changing images, see ["Overview of the HP Precisionscan Pro software" on page 39.](#)

---

**Tip** You can change the default settings for some buttons on the scanner. See ["Changing settings for buttons" on page 34.](#)

---

## Overview of scanner buttons

For a list of buttons available on your scanner, see the ["Front panel and accessories comparisons" on page 3](#).

### Scan To



Scan to the HP PrecisionScan Pro software. View the image or make adjustments, such as changing resolution or resizing. If your scanner also has a Select Destination button (some models only) next to the Scan To button, you can select and scan to other programs on your computer.

### Select Destination (some models only)

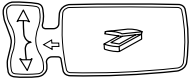

Press this button up or down to choose a program, then press the Scan To button. The Scan To button scans the item using settings optimized for that destination and sends the scan to that destination.

### Share-to-Web (some models only)



Scan a photo and send it to the HP Share-to-Web wizard on your computer. The HP Share-to-Web wizard uploads the image to a website.

### Photo Reprint



Scan a photo and send it to the HP Photo Printing software for printing multiple photos on one page, or for creating photo album pages.

### E-mail



Scan using settings optimized for e-mail. The e-mail program window automatically launches so you can compose your message. The scanned image becomes a file attachment in the new e-mail message. If you do not have a supported e-mail program, this button allows you to save the scanned image as an e-mail file.





### Copy

Print copies using settings optimized for printing. At the computer, you can click **Cancel** to choose additional copy settings in the HP Scanjet Copy Utility before the pages print.

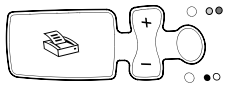

### Number of copies (some models only)

Choose the number of copies before pressing Copy. The liquid crystal display (LCD) display shows the number of copies selected.

### Color/Black & White copy (some models only)

Choose the color or black and white setting before pressing Copy to ensure the best settings are used. Only use color copy if you are printing to a color printer and want a color copy. The light adjacent to the currently selected choice is lit.



### More Options (some models only)

Open the dialog box to change settings, such as output quality, for some buttons on the scanner. If your scanner does not have this button, change button settings with the HP Scanjet Button Options program on your computer. See "[To change settings for buttons or update destinations](#)" on page 34.



### Cancel (some models only)

Cancel a scan while the scanner is in the process of scanning, or cancel a series of scans from the HP Scanjet Automatic Document Feeder (ADF).



### Power Save

Puts the scanner in an energy-conservation mode. The scanner lamp and a small indicator light near the Power Save button turn off. To use the scanner, press any button on the front panel of the scanner or start a scan from the computer. The scan begins when the lamp is ready.

## Scanning quickly with scanner buttons

Use the scanner buttons to scan quickly to a destination using settings optimized for that destination. A destination is a printer, file, or program, such as your e-mail or word-processing program.

If you are scanning slides or negatives using the HP Scanjet Transparency Adapter (XPA), you must scan from the HP Precisionscan Pro software. See "[Scanning from the XPA](#)" on [page 77](#).

## Scanning to the HP Precisionscan Pro software

When you use the Scan To button (  ), you send directly to the HP Precisionscan Pro software. Using the HP Precisionscan Pro software, you can preview scanned images and make changes to the images before you send them to a destination or file them.

### *To scan to the HP Precisionscan Pro software*

Before you begin, make sure no other program name displays in the scanner's LCD window or that the LCD window reads Ready. (Some models only, see "[Front panel and accessories comparisons](#)" on [page 3](#)). If another program name displays, press the Select Destination button (  ) up or down until HP Precisionscan is listed in the scanner's LCD window.

- 1 Close the HP Scanjet Copy Utility program if it is open on your computer.
- 2 Place the original face down on the scanner glass and close the lid. To load items in the ADF, see "[Scanning from the ADF](#)" on [page 76](#).
- 3 Press the Scan To button on the front panel of the scanner.
- 4 Your computer opens the HP Precisionscan Pro software. A preview of the scan appears in the Precisionscan Pro software window.

For more information, see "[Scanning from HP Precisionscan Pro](#)" on [page 39](#).

## Scanning to another program

On some models, you can select from a list of destinations (including the HP Precisionscan Pro software) on the front panel LCD display, then scan directly to the selected destination.

When you select a program other than HP Precisionscan Pro using the Select Destination button (  ), the scanner will automatically use settings optimized for the destination you choose. You do not view or change scanned images before they go to the destination.

### *To scan directly to another program*

- 1 Close the HP Precisionscan Pro and HP Scanjet Copy Utility programs if they are open on your computer.
- 2 Place the original face down on the scanner glass and close the lid. To load items in the ADF, see ["Scanning from the ADF" on page 76](#).
- 3 If your scanner has a Select Destination button next to the Scan To button (  ), press the Select Destination button up or down until the destination you want to scan to is listed in the scanner's LCD window.
- 4 Press the Scan To button on the front panel of the scanner.
- 5 The item is scanned using settings optimized for the program you selected. The program launches and the scan is sent to the program.

**Note:** For information about updating the destinations for scanner buttons, see ["Changing settings for buttons" on page 34](#).

---

**Tip** If your scanner does not have a Select Destination button next to the Scan To button, you can scan to other programs through the HP Precisionscan Pro software. See ["Sending to a program" on page 61](#).

---

## Sending a scan to a website

On some models, you can share images with other people by scanning directly to the Web with the Share-to-Web button (  ). People you know can view photos and other items by visiting your website, which will have its own address.

### *To place a scan on a website*

- 1 Close the HP Precisionscan Pro and HP Scanjet Copy Utility programs if they are open on your computer.
- 2 Place the original face down on the scanner glass and close the lid. To load items in the ADF, see "[Scanning from the ADF](#)" on [page 76](#).
- 3 Press the Share- to- Web button on the front panel of the scanner. The scanner scans the item using settings optimized for the Web. Your computer opens the **HP Share-to-Web** wizard.
- 4 Follow the instructions on the screen to finish posting the scanned image to your website.

---

### Tip

If your scanner does not have a Share-to-Web button, scan to the web using your HP Precisionscan Pro software. See "[Placing a scan on a website](#)" on [page 64](#)." 

---

## Scanning for photo reprints

You can scan photographs and prepare them for photo reprints by using the Photo Reprint button (  ). Photo reprints optimize the use of photo paper, allowing you to print multiple photos on one page. You can also create pages with multiple photographs for projects such as photo albums.

At the computer, use the HP Photo Printing software provided with your scanner to arrange photographs, make adjustments, and print photographs.

### *To create a photo reprint*

- 1 Close the HP Precisionscan Pro and HP Scanjet Copy Utility programs if they are open on your computer.
- 2 Place the original face down on the scanner glass and close the lid.
- 3 Press the Photo Reprint button on the front panel of the scanner. The scanner scans the item using settings optimized for photograph printing. Your computer opens the HP Photo Printing software.

### *To view the HP Photo Printing Quick Reference Guide*

The HP Photo Printing software is available in English only in some countries. For help in your language, press the **Photo Reprint** button on the scanner, click **Help**, and then click **Quick Reference Guide**.

## Sending a scan using e-mail

When you send e-mail using the E-mail button (  ), the scanner scans the item using default settings optimized for mailing. If you have a supported e-mail program, the scanned image automatically appears as a file attachment in a new e-mail message, which you then address and send. If your e-mail program is not supported, choose E-mail anyway. The computer prompts you to save the item as a file, and then the scanner completes the scan. Open your e-mail program and attach the file to a message as you normally do.

**Note:** When prompted to save the file, be sure to select the file type you want.

---

**Tip** To view the scanned item before you send it, open the file attachment from the new e-mail message.

---

### *Supported e-mail programs*

Supported e-mail programs allow the scanner to scan an item as a file and attach it to a new e-mail message. If a scanned image automatically appears as a file attachment in a new e-mail message, your e-mail program is supported.

### *Unsupported e-mail programs*

If you are using an unsupported e-mail program, such as the Web-based program Microsoft Hotmail<sup>®</sup>, the scanner cannot scan items directly into an e-mail message. The scanner prompts you to save the item as a file and then scans the item with settings optimized for e-mail. (When prompted to save the file, be sure to select the file type you want.) After saving the image as a file, open an e-mail message and attach the file as you normally do.

To be prompted to save the file, make sure that **E-mail File** is selected as the destination in the button options.

See "[Changing settings for buttons](#)" on [page 34](#) to check or change which e-mail program is set as the default, or to set **E-mail File** as the default.

*To e-mail a scan from the scanner*

- 1 Close the HP Precisionscan Pro and HP Scanjet Copy Utility programs if they are open on your computer.
- 2 Place the original face down on the scanner glass and close the lid. To load items in the ADF, see ["Scanning from the ADF" on page 76](#).
- 3 Press the E-mail button on the scanner.
- 4 If the computer prompts you for the original type, select **Photo** or **Document**. If you need help choosing the original type, see ["Selecting original type for e-mail" on page 32](#).
- 5 If you do not have a supported e-mail program, the computer prompts you to save the image as a file. In the Save As dialog box, name the file, choose a location in which to save it, and click **Save**.  
If the computer prompts you for an attachment file name, enter a name in the **File name** box. If you need more help, see ["Naming e-mail attachments" on page 32](#).

- 6 If you are scanning a document without using an ADF, the computer may prompt you for another page. Do one of the following:
  - If you do not have more pages to scan, click **Done**.
  - If there are additional pages of this item, load the next page and click **Scan**. Repeat until all pages are scanned. Then, click **Done**.

**Note:** To turn this feature off, see ["To change settings for buttons or update destinations" on page 34](#).
- 7 If you have a supported e-mail program, the scanned image automatically appears as a file attachment in a new message. Address the message and send it as you normally do. If you do not have a supported e-mail program, the computer confirms that the item is saved to a file. Open your e-mail program and attach the saved file.

### *Selecting original type for e-mail*

If the software prompts you for an original type, you have two choices, Photo or Document. The scanner will use optimized scan settings for your item depending on your choice. Use the following guidelines to determine the best original type for your needs:

- Select Document if the item contains text or both text and graphics. This produces a .pdf file.
- Select Photo if the item is a printed photograph or image (negatives and slides not supported). This produces a .jpg file.

If you frequently scan the same type of original, and do not want the Original Type screen to appear each time, you can turn it off. To do so, choose **Photo** or **Document**, then check the box labeled **In the future, use this setting. Do not prompt me.**

To turn the original type prompt back on, see ["Changing settings for buttons" on page 34.](#)

### *Naming e-mail attachments*

The computer will prompt you each time for a filename. If you do not want to be prompted, and you want the scanning software to assign an attachment name automatically, check the box labeled **In the future, name the file automatically. Do not prompt me.**

To turn the attachment name prompt back on, see ["Changing settings for buttons" on page 34.](#)

**Save as type** displays the file type for the e-mail attachment. A photo original type results in a .jpg file type. A document original type results in a .pdf file type.

**Note:** If you need to save the item as a file type other than .jpg or .pdf, scan and save the item using the HP Precisionscan Pro software. See ["To save to a file" on page 62.](#)



## Printing copies

You can scan an item and send it to a printer to make copies using the Copy button (  ). Note that when you make copies, each page is treated as a separate print job, so the printer will not collate copies.

### *To print copies from the scanner*

- 1 Close the HP Precisionscan Pro program if it is open on your computer.
- 2 Place the original face down on the scanner glass and close the lid. To load items in the ADF, see ["Scanning from the ADF" on page 76](#).
- 3 (Some models only, see ["Front panel and accessories comparisons" on page 3](#).) On the scanner, select color or black and white copies.
- 4 (Some models only, see ["Front panel and accessories comparisons" on page 3](#).) On the scanner, select the number of copies. The default setting is one copy.
- 5 Press the Copy button on the scanner. Unless you click **Cancel**, the number of copies specified in the scanner LCD window will print directly to the default printer.
- 6 To reduce or enlarge the copies, lighten or darken them, or change which printer prints them, click **Cancel** on the computer to set options in the HP Scanjet Copy Utility. Change options and click **Copy**.

---

### Tip

If your scanner doesn't have buttons to select color or black and white, or number of copies, use the HP Scanjet Copy Utility.

---

## Changing settings for buttons

When you use the scanner buttons, the scanner scans the item using settings optimized for the destination, such as e-mail, that is associated with that button. You can change the default settings for some scanner buttons. Settings are applied to all items being scanned until you manually change the settings. You can also update the scanner button destinations to include new programs on your computer.

---

**Tip** To change the settings only for the current item, you might want to scan using the HP Precisionscan Pro software instead. See "[Scanning from HP Precisionscan Pro](#)" on page 39.

---

*To change settings for buttons or update destinations*

- 1 Do one of the following:
  - (Some models only, see "[Front panel and accessories comparisons](#)" on page 3.) On the scanner, press the More Options button (  ).
  - On the **Start** menu, point to **Programs**, point to **HP Scanjet Utilities**, and click **HP Scanjet Button Options**.
- 2 Click the tab for the options you want to change.
- 3 For the E-mail tab options, change the settings and click **OK**.
- 4 For the General tab options, click **Update**. The software automatically searches your computer for supported new programs and updates the scanner button destinations. When the update is complete, click **OK**.

To restore default E-mail button options

- 1 Do one of the following:
  - (Some models only, see "[Front panel and accessories comparisons](#)" on page 3.) On the scanner, press the More Options button (  ).
  - On the **Start** menu, point to **Programs**, point to **HP Scanjet Utilities**, and click **HP Scanjet Button Options**.
- 2 Click the E-mail tab.
- 3 Click **Restore Defaults**, then click **OK**.

## List of options for scanner buttons

### E-mail tab options

This tab contains the scanning options that are applied to items you scan using the E-mail button (  ).

#### Destination

Select the e-mail program into which scanned images will be placed as files when scanning is completed. If no compatible e-mail programs are installed on the computer, you cannot scan directly to e-mail. Instead, select **E-mail File** here in the Destination field. Then when you press the E-mail button (  ) on the scanner, you will be prompted to save the scanned image as a file, which you can manually attach to an e-mail message as you normally do.

If the e-mail program you want does not appear in the list, you can use the update button under the General tab to update the destination list for the E-mail button. If this is a newly released e-mail program, check the page for this scanner on the HP support website for new drivers to support the e-mail program. Otherwise, visit the page for this scanner on the HP support website to check for known conflicts with the program you want.

Visit the HP support website at:

<http://www.hp.com/go/support>

### Original type

Choose one:

- **Photo**
- **Document**
- **Prompt for original type each time**

By default, the original type is set to **Prompt for original type each time**. If you scan a variety of original types, this allows you to make the original type choice each time. Use **Photo** or **Document** if you are frequently scanning the same type of original.

### Prompt for e-mail attachment name

Check the **Prompt for e-mail attachment name** box to enter a name each time for e-mail attachments. Uncheck the **Prompt for e-mail attachment name** box if you want the scanning software to assign an attachment name automatically.

### Original size

This option is available for Document original types only. Select the size that most closely matches the item you are scanning. Some scanners support an optional automatic document feeder (ADF) that allows you to scan pages larger than the scanner glass.

### Quality (for documents)

This option is available for Document original types only. Choose one:

- **Small file size with lower quality** creates black and white scans at 100 dpi.
- **Normal** creates grayscale scans at 200 dpi.
- **Large file size with high quality** creates color scans at 300 dpi.

The file type is .pdf.

### Prompt to scan additional pages

This option is available for Document original types only. Check the **When done scanning, prompt to scan additional pages when ADF is not being used** box for a prompt to add more pages to the current document. This option is useful if you scan documents without an ADF and want multiple pages in a single .pdf file attachment. Uncheck the **When done scanning, prompt to scan additional pages when ADF is not being used** box to turn this option off.

### Area to scan

This option is available for Photo original types only. Choose one:

- **Scan only items detected on the scanner bed** automatically crops a photograph on the scanner bed.
- **Scan entire scanner bed** scans the full size of the scanner bed without cropping.

### Quality (for photos)

Choose one:

- **Small file size with lower quality** creates scans at 75 dpi.
- **Normal** creates scans at 100 dpi.
- **Large file size with high quality** creates scans at 150 dpi.

For color photos, output type is True Color. For black and white photos, output type is Grayscale.

### Scan in color

This option is available for Photo original types only. To retain color when scanning images, select the **Scan in color** box. To scan images in black and white, clear the **Scan in color** box.

### *General tab options*

If you install a new software program on your computer after you install the HP scanning software, update the scanner button destinations using the General tab options. An update ensures that the scanner buttons can send to supported new destinations on your computer. In order to update the destinations, your scanner must be attached to the computer before you press **Update**.

In the General tab, click **Update**. The software automatically searches your computer for supported new programs and updates the scanner button destinations. When the update is complete, click **OK**.

**Note:** If your scanner has a Select Destination button next to the Scan To button, not all destinations appear in the scanner's destination list. For example, printers, e-mail programs, and saving to a file are not included. The list is also limited to the first 18 destinations found by the HP scanning software. You can access additional destinations through the HP PrecisionScan Pro software. See "[To send to a program](#)" on page 61 for more information.

### **Power Save**

Use the Power Save button (  ) to conserve energy when you are not using the scanner. When you press the Power Save button, the scanner lamp and a small indicator light near the Power Save button turn off and the scanner lamp returns to its starting position.

To use the scanner again, press any button on the front panel of the scanner or start a scan from the computer. After a short warm-up cycle, the scan begins.

### **Cancel (some models only)**

The Cancel button (  ) cancels a scan in progress. When you press the Cancel button during a scan, the lamp shuts down and returns to its starting position. If you press the Cancel button during a scan from the ADF, the ADF ejects any pages that are in the process of scanning.



# 3 Scanning from HP Precisionscan Pro

Using the HP Precisionscan Pro software, you can preview scanned images and make changes to the images before you send them to a destination or file them. You start the HP Precisionscan Pro software from a scanner button or the **Programs** group in the **Start** menu.

You can also start the HP Precisionscan Pro software from another program, such as a word-processing or image-editing program, if the program is compliant with TWAIN. See ["Scanning from other programs \(TWAIN\)" on page 71](#) for more information.

## Overview of the HP Precisionscan Pro software

The HP Precisionscan Pro software provides preview capabilities and tools for changing an image. Some of the changes you can make include:

- Select only part of, or crop, the preview image to become the final scanned image.
- Change the resolution.
- Resize the scanned image.
- Change the contrast.

## Starting the HP Precisionscan Pro software

To start the HP Precisionscan Pro software, press the Scan To button () , or on the **Start** menu, point to **Programs**, and click **HP Precisionscan Pro**. The software starts.

To view the function of a command, place the cursor over the command until an explanation appears.

For more information about the types of assistance the software itself offers, see "[Finding help for using the software](#)" on this page. For more information about keyboard shortcuts, menu items, toolbars, and cursor appearance, see "[Using software commands and controls](#)" on [page 109](#).

## Finding help for using the software

The HP Precisionscan Pro software provides a variety of assistance.

### Guided Steps

Use the Guided Steps for step-by-step help as you move through the scanning process. By default, the Guided Steps appear along the left side of the preview window. As you become more comfortable with the software, you can hide them. To show or hide the Guided Steps, on the **View** menu, click **Guided Steps**. Or, on the toolbar click .

**Note:** Help is available for computers running Internet Explorer version 4.0 or greater. See "[Resolving issues that did not generate messages](#)" on [page 87](#).

### Smart Friends

Smart Friends are tips that appear automatically to notify you of potential problems. For example, if you are setting a very high resolution but want to use e-mail to send the scanned image, a Smart Friend would alert you that the file will probably be too large for e-mail. To turn individual messages off, select the **Don't remind me again** check box in the message's dialog box. To turn all messages off, click **Disable All Smart Friends** on the **Help** menu. To turn all messages back on, click **Enable All Smart Friends**.

### Online Help

The online Help is an easy-to-use source of information about using the scanner and software, troubleshooting, support, and specifications. To gain access to the Help: on the **Help** menu, click **Contents**. Or, click the **Help** button in any dialog box in which it appears.

**Note:** Help is available for computers running Internet Explorer version 4.0 or greater. See "[Resolving issues that did not generate messages](#)" on [page 87](#).

### What's This? Help

Click  and click a button, menu, or command to find more information about that feature.



## Performing a new scan

Once you start a new scan, the scanner does a preliminary scan of the item and displays the scanned image in the HP Precisionscan Pro software. Then, you can see the scanned image and edit it, if necessary, before sending it to a destination or saving it as a file.

### *To start a new scan*

Use these steps to start a scan from the HP Precisionscan Pro software. To start a scan from a scanner button, see ["Scanning quickly with scanner buttons"](#) on page 26.

- 1 Place the original face down on the scanner glass and close the lid.

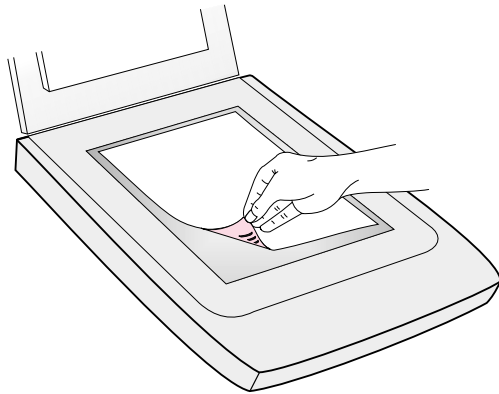

**Note:** To load items in the HP Scanjet Automatic Document Feeder (ADF), see ["Scanning from the ADF"](#) on page 76.

- 2 On the **Start** menu, point to **Programs**, and click **HP Precisionscan Pro**. The software starts.

- 3 Start the scan in one of these ways:

- In the HP Precisionscan Pro software, click  on the toolbar or the Guided Steps (if visible).
- In the HP Precisionscan Pro software, click **New Scan** on the **Scan** menu.

The scanned image appears in the HP Precisionscan Pro software. This scanned image is the preview image. You can make changes, such as selecting only part of the image or adjusting the contrast.

When you send the image to another program such as e-mail, place the image on a website, or save it as a file, the scanner performs a final scan of the item that includes any changes you made. Directions for making optional adjustments and completing the scan appear in this section.

## Cropping or selecting an area for final scan

Once a scanned image appears in the HP Precisionscan Pro software, you must select which area becomes the final scanned image by creating a selection area. When you create a selection area, a dotted selection border appears around the area:



For information about the appearance of the cursor when it is over an area of the selection border, see "[Context-sensitive cursors](#)" on [page 116](#).

### Tip

If you only want to look more closely at an area without changing what will be included in the final scan, see "[Getting a closer look \(zooming\)](#)" on [page 43](#).

*To crop or select an area for final scan*

Do one of the following:

- Move the cursor over the area you want and click.
- When the cursor looks like this: , click on one corner of the area you want and drag the cursor to the opposite corner to draw a rectangular selection area.
- On the **Edit** menu, click **Select All**. The entire scanner bed, including blank areas, is selected.

*To change the selection area*

Click on a handle of the selection border and drag to change the selection area.

*To move the selection border*

Move the cursor over the selection area. When the cursor looks like this: , click and drag the selection border to the new location.

*To remove the selection border*

Do one of the following:

- Press **Esc**.
- On the **Edit** menu, click **Unselect All**.

## Getting a closer look (zooming)

Zoom in on the selection area to look at it more closely or make changes to it. Zoom out to view the entire preview image, or so you can select a different area of the image to view. Zooming in on the selection area before making changes or performing a final scan provides the best final results. The zoom commands are not available if you have not created a selection area.

Zooming in and out *does not* change which part of the image becomes the final scan, nor does it change the final output size (physical output dimensions). To change which part of the image becomes the final scanned image, see "[Cropping or selecting an area for final scan](#)" on [page 42](#). To resize the image, see "[Resizing \(output dimensions\)](#)" on [page 45](#).

### To zoom in

After creating a selection area, do one of the following:

- On the **View** menu, click **Zoom in**.
- Click .

### To zoom out

Do one of the following:

- On the **View** menu, click **Zoom out** to return to the original view of the image.
- Click .

## Selecting output type

When **Automatically Set Type** is selected, the scanning software automatically chooses an output type based on the type of item you are scanning. However, you can change the output type yourself when you want. Choose the output type based on how you will use the final scanned image as well as the type of item you are scanning.

### To select an output type

1 Do one of the following:

- If it is not already selected, click **Automatically Set Type** on the **Output Type** menu, to allow the software to choose the best output type for this type of original item.
- To change the output type only for this scan, keep **Automatically Set Type** selected and select an output type you want from the **Output Type** menu. See "[List of output types](#)" on [page 44](#).
- To change the output type for this scan and all other scans in this session, clear **Automatically Set Type** and select an output type you want from the **Output Type** menu. See "[List of output types](#)" on [page 44](#).

---

### Tip

For help choosing an output type, view the Guided Steps. If they are not already displayed, click . In step 3 "Confirm that the output type is what you want," select **Help Me Choose**.

---

*List of output types*

For these uses	Use this output type
Color photos or drawings with lots of shading to be: <ul style="list-style-type: none"> <li>● printed on a color printer.</li> <li>● displayed on a color monitor set to millions of colors.</li> <li>● displayed on the Web and saved in the .jpg or .png file format.</li> </ul>	True Color (16.7 million colors)
Color photos or drawings with shading to be: <ul style="list-style-type: none"> <li>● printed to a color printer.</li> <li>● sent via e-mail.</li> <li>● used in any way that requires a small file size.</li> <li>● viewed on a computer screen.</li> </ul>	256-Color (optimized palette)
Color photos or drawings with shading to be printed to a B&W printer.	Grayscale
B&W photos and drawings with shading to be used for any purpose.	Grayscale
B&W drawings without shading to be placed in another program without resizing in the other program.	Black & White Bitmap
B&W drawings without shading to be resized in another program.	Black & White Scalable
Any image to be saved in .gif file format and displayed on the Web.	256-Color (web palette)
Text that needs to be editable in a word-processing program.	Editable Text (OCR)
Text that needs to be editable and graphics to be used.	Text and Image
Color drawings or logos without much shading and with a concentrated area of a single color. The image is to be used for any purpose.	Spot Color (16-color)

*To reset output type*

On the **Output Type** menu, click **Automatically Set Type**. The software chooses the best output type based on the image inside the selection area.

## Making optional adjustments, basic

These tools are needed most often, but using any of them is optional. Depending on the output type chosen, some tools will not be available.

### Resizing (output dimensions)

You can resize the image before you do the final scan by changing the output dimensions. Resizing the scanned image to the actual dimensions you need before performing the final scan helps ensure the best image quality.

---

**Tip** If you need to resize images to fit in a file, such as a word-processing document, resize them here in the scanning software. Resizing images in the other program can cause them to be fuzzy or have jagged edges.

---

*To resize an image*

- 1 On the **Tools** menu, click **Resize**. The Resize dialog box opens.
- 2 Do one of the following:
  - If necessary, select a unit of measure in the **Units** field. In the Output Dimensions area, type a new value in the **Width** or **Height** field and press **ENTER**.
  - In the **Scale** field, select a scale percentage.

New values appear in the **Scale**, **Width**, and **Height** fields, but the selection area and the scanned image on screen remain the same. Resizing occurs when you complete the scan.

- 3 If you want, click . This locks the output dimensions you defined so you can change the selection area without changing the output dimensions. When you change the selection border, the software resizes the border proportionally. The output dimensions remain the same.

## Changing resolution

Resolution determines the amount of data in a scanned image. The scanning software chooses the optimal resolution based on the output type. This resolution generally does not need to change.

If you do change the resolution, choose one no higher than the capabilities of the monitor or printer and one appropriate for the type of scanned image. For example, to print on a 600 dpi printer, choose 600 for black and white bitmap images, but choose only 200 for color or grayscale images. These resolutions produce optimal quality while keeping file sizes small.

Selecting higher resolutions for color images increases file size while not increasing quality. If you double the resolution, the file size quadruples. Large file sizes can prevent you from doing certain tasks, such as e-mailing, or can take up too much space on your computer.

For help choosing a resolution based on the type of original item and destination, see ["Tips for best image quality" on page 67](#).

### *To change resolution*

- 1 On the **Tools** menu, click **Change Resolution**.
- 2 Do one of the following:
  - Select a value from the list.
  - Type a value between 12 and 999,999 in the field and press **ENTER**.

The resolution changes as soon as you select a value.

### *To reset resolution*

On the **Tools** menu, click **Change Resolution**. Then, click .

---

### Tip

You can add the Change Resolution tool to the toolbar. See ["To add Change Resolution and Sharpen tools to the toolbar" on page 114](#).

---

## Changing contrast



The contrast is controlled by the midtone, highlight, and shadow settings. See ["Changing midtones" on page 50](#), ["Changing highlights" on page 51](#), and ["Changing shadows" on page 52](#).

## Rotating an image

You can rotate the image in 90-degree increments clockwise or counterclockwise. You might need to rotate the image if you placed the bottom of the item at the top of the scanner glass, or if the item was sideways. Items such as negatives in their template often scan sideways.

### To rotate an image

Do one of the following:

- *To rotate an image clockwise:* On the **Tools** menu, click **Rotate right 90°**. Or, click  on the toolbar. Repeat to continue turning.
- *To rotate an image counterclockwise:* On the **Tools** menu, click **Rotate left 90°**. Or, click  on the toolbar. Repeat to continue turning.

### Tip

Do not rotate scanned images with the output types Editable Text, Text and Image, and Black & White Scalable. Rotating images with these output types results in a distorted image.

## Mirroring (reversing) an image

You can mirror, or reverse, an image from side to side on the vertical axis. Mirroring an image allows you to see the elements of the image on the opposite side of their actual position. Mirroring can be particularly useful for items such as negatives that might be placed in their template backward and scanned in reverse.

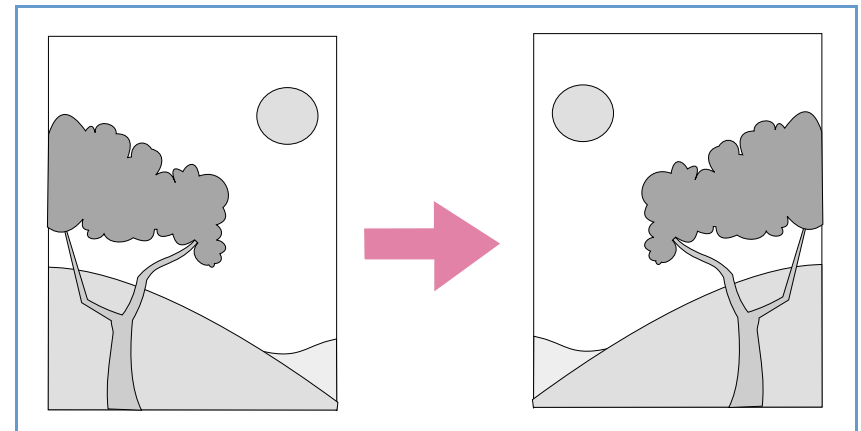

### To mirror (reverse) an image

On the **Tools** menu, click **Mirror**. Repeat to return to the original layout.

### Tip

Do not mirror scanned images with the output types Editable Text, Text and Image, and Black & White Scalable. Mirroring images with these output types results in a distorted image.

## Sharpening an image

Increasing sharpening enhances detail in the image. The HP Precisionscan Pro software automatically selects the optimal sharpen level, but you can change it.

You might want to increase sharpening if the image looks fuzzy. Conversely, you might want to decrease sharpening if the original item has flaws or marks on it. Increasing sharpening, or increasing it too much, can accent the flaws and create undesirable patterns.

### *To sharpen an image*

- 1 On the **Tools** menu, click **Sharpen**.
- 2 Select a sharpen level from the list. The viewer shows the effect of the changes on the image.

### *To reset sharpen levels*

- 1 On the **Tools** menu, click **Sharpen**.
- 2 Click .

---

### Tip

You can add the Sharpen tool to the toolbar. See ["To add Change Resolution and Sharpen tools to the toolbar"](#) on page 114.

---

## Resetting all adjustments

You can reset images to the optimal (default) values the scanning software chose for the image. Optimal values are based on the output type selected. Resetting removes all adjustments you have made except the output type, zoom level, or the selection area.

### *To reset all adjustments*

Do one of the following:

- On the **Edit** menu, click **Reset Tools**.
- On the toolbar, click .



## Making optional adjustments, advanced

These optional adjustments are ones that most people generally do not use or need, but some advanced users might want them for special effects or other needs. Depending on the output type chosen, some tools are not available.

### Inverting the image

Use the Invert command to convert white areas of an image to black and black to white. For color images, a color is converted to its complementary color. Generally, this command is useful for drawings and spot color images.

#### *To invert the image*

On the **Advanced** menu, click **Invert Colors**. Repeat to reverse the colors again.

## Changing midtones

The midtone setting lets you lighten or darken the middle values in an image. The range for the number in the **Midtone** field is 1.0 to 4.0. Moving toward 1.0 darkens the image. Moving toward 4.0 lightens the image.

To adjust midtones for slides, negatives, or other transparent items, use "[Adjusting midtones for slides or negatives](#)" on page 81.

Midtone set at 2.2  
(the default)



Midtone set at 3.0



### *To lighten the image overall*

- 1 On the **Advanced** menu, click **Adjust Exposure**.
- 2 Do one of the following:
  - Drag the Midtone slider to the right.
  - Type a higher number in the **Midtone** field and press **ENTER**.
  - Click the **Up** arrow next to the **Midtone** field.

### *To darken the image overall*

- 1 On the **Advanced** menu, click **Adjust Exposure**.
- 2 Do one of the following:
  - Drag the Midtone slider to the left.
  - Type a lower number in the **Midtone** field and press **ENTER**.
  - Click the **Down** arrow next to the **Midtone** field.

### *To return to the default settings*

- 1 On the **Advanced** menu, click **Adjust Exposure**.
- 2 Click **Auto** to return the midtone, highlight, and shadow to the default settings for this scanned image. Clicking **Auto** also returns output levels to the defaults. See "[Setting pixel output levels](#)" on page 54.

## Tip

If you are sharing the image with others who will be viewing it on a computer screen, the Midtone value of 2.2 is recommended because it is an average value that works with many different monitors.

## Changing highlights

The highlight is the value in the image that is represented on the screen as white. All values lighter than the highlight also appear as white.

The image has a default highlight setting. Selecting a higher number makes more of the lighter values distinct, which increases detail in light areas. Selecting a lower number makes fewer of the lighter values distinct, which reduces detail in the light areas.

To adjust highlights for slides, negatives, or other transparent items, use "[Adjusting highlights for slides or negatives](#)" on page 82.

Highlights set at 215

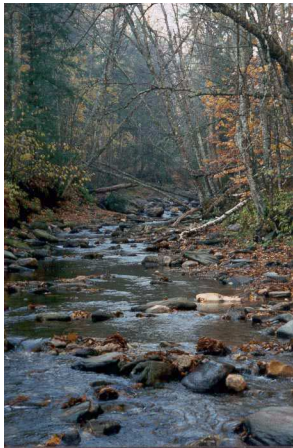

Highlights set at 122

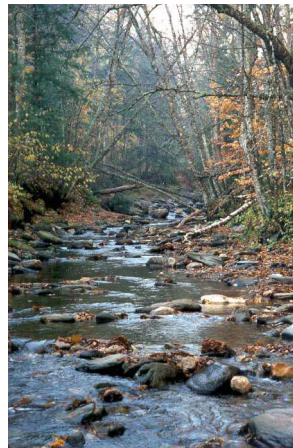

*To increase detail in lighter areas*

- 1 On the **Advanced** menu, click **Adjust Exposure**.
- 2 Do one of the following:
  - Drag the Highlight slider toward the right.
  - Type a higher number in the **Highlights** field and press **ENTER**.
  - Click the up arrow next to the **Highlights** field.

*To decrease detail in lighter areas*

- 1 On the **Advanced** menu, click **Adjust Exposure**.
- 2 Do one of the following:
  - Drag the Highlight slider toward the left.
  - Type a lower number in the **Highlights** field and press **ENTER**.
  - Click the down arrow next to the **Highlights** field.

*To choose a value as the highlight value*

Click  (white eyedropper). When the cursor changes to the eyedropper, move it over the area you want to be the highlight and click.

*To return to the default settings*

- 1 On the **Advanced** menu, click **Adjust Exposure**.
- 2 Click **Auto** to return the midtone, highlight, and shadow to the default settings for this scanned image. Clicking **Auto** also returns output levels to the defaults. See "[Setting pixel output levels](#)" on page 54.

## Changing shadows

The shadow is the value in the image that is represented on the screen as black. All values darker than the shadow also appear as black.

The image has a default shadows value. Selecting a lower number makes more of the darker values distinct, which increases detail in dark areas. Selecting a higher number makes fewer of the darker values distinct, which reduces detail in the dark areas.

To adjust shadows for slides, negatives, or other transparent items, use "[Adjusting shadows for slides or negatives](#)" on page 82.

Shadows set at 10



Shadows set at 3



*To increase detail in darker areas*

- 1 On the **Advanced** menu, click **Adjust Exposure**.
- 2 Do one of the following:
  - Drag the Shadows slider toward the left.
  - Type a lower number in the **Shadows** field and press **ENTER**.
  - Click the down arrow next to the **Shadows** field.

*To decrease detail in darker areas*

- 1 On the **Advanced** menu, click **Adjust Exposure**.
- 2 Do one of the following:
  - Drag the Shadows slider toward the right.
  - Type a higher number in the **Shadows** field and press **ENTER**.
  - Click the up arrow next to the **Shadows** field.

*To select a value as the shadow value*

Click  (black eyedropper). When the cursor changes to the eyedropper, move it over the area you want to be the shadow and click.

*To return to the default settings*

- 1 On the **Advanced** menu, click **Adjust Exposure**.
- 2 Click **Auto** to return the midtone, highlight, and shadow to the default settings for this scanned image. Clicking **Auto** also returns output levels to the defaults. See "[Setting pixel output levels](#)" on page 54.



## Checking for clipped areas

The lightest or darkest areas of an image that will print without any detail in them are known as clipped areas. The lightest areas, or highlights, will print as the color of the paper (without ink or toner) and therefore will have no detail. The darkest areas, or shadows, will print saturated in the blackest color of ink or toner, and therefore will also have no detail.

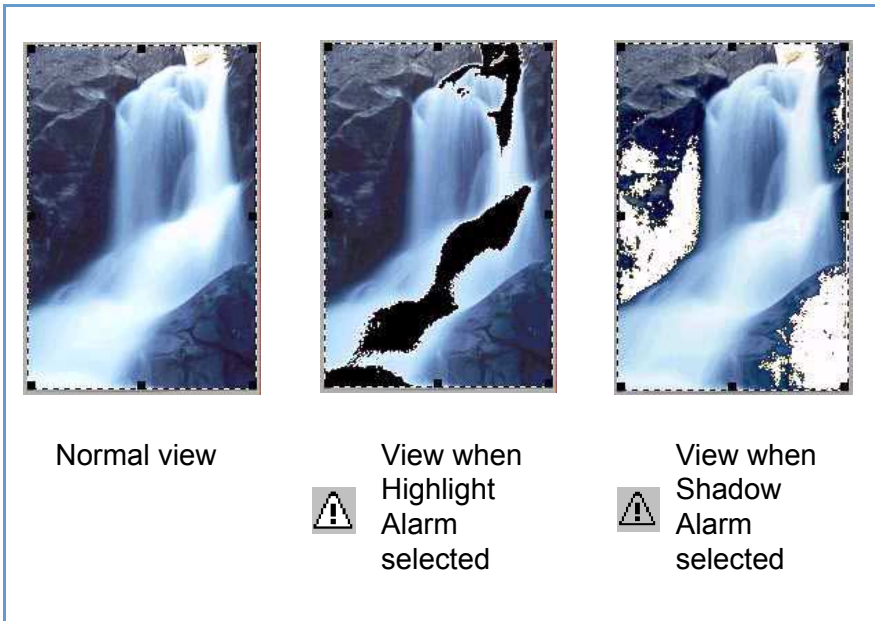

You can view and change clipped areas if you want those areas to contain detail when they print.



*To view and change clipped light (highlight) areas*

- 1 On the **Advanced** menu, click **Adjust Exposure**.
- 2 Click  (Highlight Alarm). The light areas in the image that will print as white (no detail) appear black.
- 3 In the **Highlights** setting, click the **Up** arrow repeatedly until the clipped pixels disappear from the image. The result of the change can be seen.
- 4 Click  again to turn the Highlight Alarm off.

*To view and change clipped dark (Shadow) areas*

- 1 On the **Advanced** menu, click **Adjust Exposure**.
- 2 Click  (Shadow Alarm). The darker areas in the image that will print as black (without detail) appear white.
- 3 In the **Shadow** setting, click the **Down** arrow repeatedly until the clipped pixels disappear from the image. The result of the change can be seen.
- 4 Click  again to turn the Shadow Alarm off.

## Setting pixel output levels

The output levels setting lets you create interesting effects for scanned pictures. When you select this command, the Black and White output levels appear. By default, white is set to 255, and black is set to 0.

Decreasing the White output level makes the overall image darker.

Increasing the Black output level makes the image more faded.

Changing the White output level value to 0 and the Black output level value to 255 inverts the colors in the image.

To change the ranges for the numbers in the **White** and **Black** fields, see the **Controls** tab of "[Setting preferences](#)" on page 68.

---

**Tip** To use an image as a light background for dark text, such as for an overhead transparency, increase the Black output level until the image is as faint as you want.

---

### *To change output levels*

- 1 On the **Advanced** menu, click **Adjust Exposure**.
- 2 Click the **Output Levels** check box. The dialog box expands to display the current White and Black output levels.
- 3 To change the levels, do one of the following:
  - Click one side of a slider.
  - Type a different number in the **White** or **Black** field and press **ENTER**.
  - Click the **Up** or **Down** arrow next to the **White** field or **Black** field.

The result of the changes to output levels can be seen in the preview area.

### *To return to the default settings*



- 1 On the **Advanced** menu, click **Adjust Exposure**.
- 2 Click **Auto** to return the midtone, highlight, shadow, and output levels to the default settings for this scanned image.

## Viewing RGB values and pixels

You can view the RGB values and pixel color for any spot in a color or grayscale image using the RGB meter.

To view the RGB values and pixel color for slides, negatives, or other transparent items, use "[Viewing RGB values and pixel color](#)" on [page 83](#).

*To view the RGB values and pixels*

- 1 On the **Advanced** menu, click **Adjust Exposure**.
- 2 Click  or .
- 3 Move the pointer over the image. The RGB values and pixel color appear in the RGB meter.

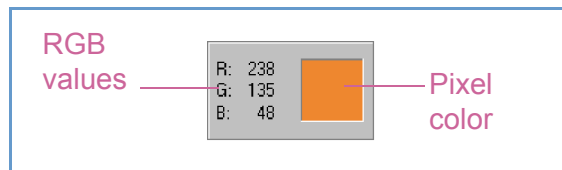

**Note:** Do not click while the eyedropper pointer is over the image unless you want to change the setting for highlight or shadow.

- 4 Click the same eyedropper button again. The RGB meter dims and the cursor returns to normal.

## About the histogram

The histogram is a graph of the distribution of pixels in the selection area. The magenta line represents the current setting for shadow. The red line represents the current setting for highlight. The midtone setting is not represented.

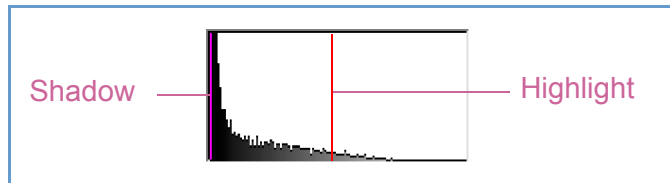

The turquoise line appears in the histogram when either eyedropper cursor is positioned over the image. This line shows you where in the histogram the pixels in that area of the image occur.

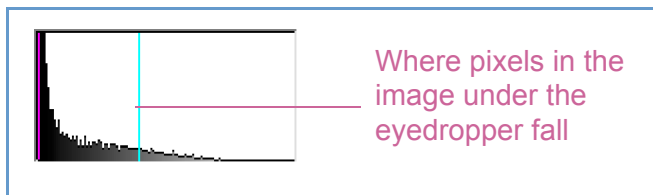

The histogram represents pixel distribution in the preview image, not in the final scanned image. Changing the selection area changes the histogram. Changing the setting for highlight or shadow does not change the histogram.

## Changing the hue

Color in an image consists of its hue and the saturation. Hue refers to the overall color cast of the image.

The software sets the hue for an image, but you can change it. You might want to change it if the image has too much of one color, or if you want to create a special effect.

*To change the hue*

- 1 On the **Advanced** menu, click **Adjust Color**.
- 2 Change the overall color of the image by doing one of the following on the color wheel:
  - Drag the indicator circle to a new area.
  - Click the arrow for a color on the outer edge of the wheel.

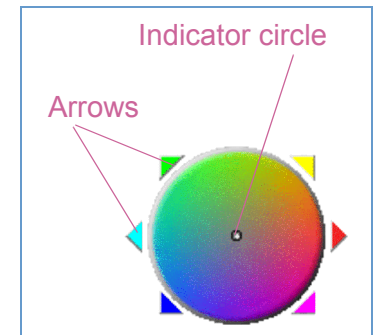

The result of the change can be seen in the image.

### Tip

If the image has too much of one color, move the indicator circle away from that color.

*To return to the default settings*

- 1 On the **Advanced** menu, click **Adjust Color**.
- 2 Click **Auto** to return to the default hue and saturation settings for this scanned image.



## Changing the saturation

Color in an image consists of its hue and the saturation. Saturation refers to the intensity of the colors.

The software sets the saturation for an image, but you can change it. You might want to change it to make colors in the image more or less vivid, or to create a special effect. The range in the **Saturation** field is 0 to 150.

### *To increase saturation*

- 1 On the **Advanced** menu, click **Adjust Color**.
- 2 Make colors more vivid by doing one of the following:
  - Click to the right of the slider.
  - Type a higher number in the **Saturation** field and press **ENTER**.
  - Click the **Up** arrow next to the **Saturation** field.

### *To decrease saturation*

- 1 On the **Advanced** menu, click **Adjust Color**.
- 2 Make colors less vivid by doing one of the following:
  - Click to the left of the slider.
  - Type a lower number in the **Saturation** field and press **ENTER**.
  - Click the **Down** arrow next to the **Saturation** field.

### *To return to the default settings*

- 1 On the **Advanced** menu, click **Adjust Color**.
- 2 Click **Auto** to return to the default hue and saturation settings for this scanned image.

## Changing the black and white threshold

Changing black and white threshold only applies to images using the Black & White Bitmap output type. The threshold is a value in the image that represents the border between black and white. All values in the image that are lighter than the threshold appear as white, and all values darker than the threshold appear as black.

The image has a default threshold value. Choosing a number closer to zero makes more values appear as white. Choosing a higher number makes more values appear as black.

Threshold at 127  
(the default for this image)



Threshold at 45



*To change black and white threshold*

- 1 Make sure that **Black & White Bitmap** is selected on the **Output Type** menu. The selection should have a dot beside it.
- 2 On the **Advanced** menu, click **Adjust Black & White**.
- 3 Do one of the following:
  - Drag the slider.
  - Type a new value in the field and press **ENTER**.
  - Click the **Up** or **Down** arrow next to the field.

*To reset black and white threshold*

- 1 On the **Advanced** menu, click **Adjust Black & White**.
- 2 Click **Auto**.

## Setting which colors become black or white in black & white bitmaps

This procedure only applies to color images that will be using the Black & White Bitmap output type. It allows you to create special effects, or to correct for originals on colored paper.

Images consist of pixels. In color images, each pixel has a varying amount of Red, Green, or Blue to create its specific color. You can determine whether the Red, Green, or Blue in each pixel turns to black or white in the final scanned image.

*To set which colors become black or white in black & white bitmaps*

- 1 Make sure that **Black & White Bitmap** is selected on the **Output Type** menu. The selection should have a dot beside it.
- 2 On the **Advanced** menu, click **Adjust Black & White**.
- 3 Select a color channel from the **Scan using channel** list.
  - Choose **Red** to change the red in the image to white. Green and blue become black. Useful for originals printed on pink or red paper.
  - Choose **Green** to change the green in the image to white. Red and blue become black. Useful for originals printed on green paper.
  - Choose **Blue** to change the blue in the image to white. Red and green become black. Useful for originals printed on blue paper.
  - Choose **NTSC Gray** to convert light shades of all colors to white and dark shades of all colors to black. (No one color becomes all white or all black.) Colors are converted to gray at a ratio of 30% red, 59% green, and 11% blue.

*To reset to the default colors*

- 1 Make sure that **Black & White Bitmap** is selected on the **Output Type** menu. The selection should have a checkmark beside it.
- 2 On the **Advanced** menu, click **Adjust Black & White**.
- 3 Choose **NTSC Gray** from the **Scan using channel** list.

## Descreening images

Use the **Descreen** command to reduce undesirable patterns in printed items you are scanning. An example of an undesirable pattern is a moiré pattern, or the circles that often appear on pictures printed in newspapers.

Note that scanning takes longer when this command is selected. Use Descreen only when you see undesirable patterns on the scan of a printed original. When Descreen is turned on or off, a new preview scan starts and image adjustments are reset.

### *To descreen images*

On the **Advanced** menu, click **Descreen**. Select the option again to turn it off.

## Resetting all adjustments

You can reset images to the optimal (default) values the scanning software chose for the image. Optimal values are based on the output type selected. Resetting removes all adjustments you have made except the output type, zoom level, or the selection area.

### *To reset all adjustments*

Do one of the following:

- On the **Edit** menu, click **Reset Tools**.
- On the toolbar, click .

## Completing the final scan

When you finish making changes, you need to complete the final scan by doing one of these tasks:

- "Sending to a program" on page 61.
- "Returning the image to a TWAIN program" on page 62.
- "Saving to a file" on page 62.
- "Printing" on page 64.
- "Placing a scan on a website" on page 64.
- "Setting the scanned image as wallpaper" on page 65.
- "Copying and pasting into another program" on page 65.
- "Dragging-and-dropping into another program" on page 65.
- "Dragging-and-dropping to the Windows Desktop or a folder" on page 66.
- "Scanning to CD" on page 66.

When you do any of these procedures, the scanner performs a final scan including your changes before sending it to the program or printer you choose, copying the image, or completing any other function.

Images are not automatically saved as files if you print them, send them to a another program, or copy and paste them into a file in another program. To use the scanned image again, be sure to save it. See "Saving to a file" on page 62.

## Sending to a program

Once you finish viewing and changing the scanned image, you can perform a final scan and send it directly to a program such as e-mail. If the program you want is not available, save the image as a file and insert it into the destination program as you normally would.

---

**Tip** If you send text to Word or another word-processing program and the text appears inside a frame you do not want, double-click the frame border and click **Remove Frame** or a similar command in the word-processing program. To prevent this from happening in the future, see "Setting preferences" on page 68.

---

### To send to a program

- 1 Do one of the following:
  - On the **Scan** menu, click **Scan To**.
  - On the toolbar or the Guided Steps (if visible), click .
- 2 Choose a program from the list and click **Scan**.
- 3 If the program you select accepts multipage files, you might be asked if you have more pages to scan to this file. Do one of the following:
  - If this is a one-page item, click **Done**.
  - If there are more pages of this item, load the next page in the scanner and click **Scan** on the computer. Repeat until all pages are scanned. Then, click **Done**.

The destination program opens and displays the scanned image.

## Returning the image to a TWAIN program

If you started the scan from a TWAIN-compliant program, you can perform a final scan and return the image to that program using this procedure. For more information about scanning using TWAIN, see "[Scanning from other programs \(TWAIN\)](#)" on page 71.

### *To return the image to a TWAIN program*

Do one of the following:

- On the **Scan** menu, click **Return Image to**.
- On the toolbar or the Guided Steps (if visible), click .

**Note:** You can also complete a final scan using WIA. See "[Scanning from other programs \(WIA\)](#)" on page 72.

## Saving to a file

Save scanned images as files when you want to use the images again later. For help deciding on which file type to use, see "[List of file types](#)" on page 63, or see "[Tips for best image quality](#)" on page 67. For definitions of File types, see the "[Glossary](#)" on page 117.

### *To save to a file*

- 1 Do one of the following:
  - On the **Scan** menu, click **Save As**.
  - On the toolbar or the Guided Steps (if visible), click .
- 2 Select a file type. See "[List of file types](#)" on page 63.
- 3 Select a name and location for the file and click **OK**.
- 4 If the **Options** button is available, more options are available for this file type. Click **Options**, change any options you want, and click **OK**.

The file type you need depends on how you will use the file. And, some file types are not available when certain output types are selected.

### List of file types

#### Image file formats

- **Bitmap (.bmp)**. Often a good choice because Windows itself and most Windows programs accept the .bmp file type.
- **FlashPix (.fpx)**. A FlashPix file contains a complete image plus several lower resolution copies of that image. The advantage of the FlashPix file format over other file formats is that a program can automatically select the best resolution for a particular job to make editing and using images faster and easier. Cannot be used with 256-color output types.
- **GIF (.gif)**. GIF is a compressed file format suitable for an image that will be used on the Web or on multiple platforms. You can save your GIF file as an interlaced GIF. Cannot be used with True Color output type.
- **JPEG (.jpg)**. JPEG is a compressed file format for images. Its strengths are small file sizes and speed. The trade-off for these advantages, though, is reduced image quality. Because each time an image is compressed with JPEG it loses a little of the image data, avoid compressing a file with JPEG more than once. JPEG is an appropriate file format for an image that will be used on the Web or on multiple platforms.

You can save your JPEG file as a progressive JPEG. When used on a Web page, a progressive JPEG is initially sent as just every other line, with the remaining lines sent immediately after. This allows a (somewhat blurry) image to display sooner. Most people prefer this. JPEG can be used only with True Color and Grayscale output types.

- **PNG (.png)**. A compressed image file format that might replace GIF. Like GIF, PNG uses non-lossy compression, which means all the visual data is saved and restored when the file is decompressed. Unlike GIF, PNG can be used with the True Color output type, as well as grayscale ones.

- **TIFF (.tif)**. Usually created by scanners, TIFF files are widely accepted by programs that work with photographs and other images. A TIFF file is a bitmapped graphic (also called a raster graphic) and can be any resolution. TIFF image files can be used on multiple platforms.
- **TIFF compressed (.tif)**. TIFF compressed files for images are smaller than standard TIFF files.
- **PCX image (.pcx)**. The PCX file format is for images used in Windows programs such as PC Paintbrush and Paint.
- **Windows Metafile (.wmf)**. The Microsoft Windows Metafile file format is used for scalable (vector) images in Windows programs. It is only available for images using the Black & White Scalable (vector) output type.

#### Text or text-and-image file formats

- **HTML (.htm)**. HTML is useful for text and graphics that will be viewed on the World Wide Web. When this format is selected for a scanned image containing both text and images, the text is converted to editable text and is saved as HTML, and the graphics are saved as GIF or JPEG files.
- **PDF (.pdf)**. PDF is a format useful for text, photos, and drawings. Use Adobe Acrobat Reader to view .pdf files. If no changes need to be made to the file, this file type is useful for sharing (as through e-mail) and filing because of its generally small file size.
- **Rich Text (.rtf)**. The .rtf format can be used with a page that contains text or text and pictures. The formatting of text in an .rtf file can usually be retained and then interpreted by other programs.
- **Text (.txt)**. Use .txt file format for saving only the text in the selection area and when you are using the **Editable Text (OCR)** output type. Text will be editable, unformatted, ASCII text.

## Printing

The selection area is the part of the image that prints. If there is no selection border, the contents of the entire scanner bed, including blank areas, print.

The **Print** command is disabled if one of these output types is selected: **Editable Text (OCR)**, **Text and Image**, or **Black and White Bitmap Scalable**. To print, you must select a different output type.

Printing does not save the image to the computer. Save the scanned image to a file to use the image later.

### *To print*

- 1 Do one of the following:
  - On the **Scan** menu, click **Print**.
  - On the toolbar, or the Guided Steps (if visible), click .
- 2 In the **Print** dialog box, select the options you want and click **OK**.

## Placing a scan on a website

Share photos with other people by scanning directly to the Web. People you know can view the photos and other items by visiting your website, which will have an address you can give them.

---

### Tip

If you want to place a scan on a site other than an HP Share-to-Web website, save the scanned image as a file and then place the file on the site as you normally do.

---

### *To place a scan on a website*

- 1 Do one of the following:
  - On the **Scan** menu, click **Scan To**.
  - On the toolbar, or the Guided Steps (if visible), click .
- 2 Select **HP Share-to-Web** from the list and click **Scan**.
- 3 Follow the instructions on the screen to finish posting the scanned image to the website.



## Setting the scanned image as wallpaper

When you choose this command, the software performs the final scan and uses the results as the wallpaper on your Windows Desktop. Right-click on the scanned image and click **Set as Wallpaper**.

To change to a different wallpaper, right-click on the Windows Desktop and click **Properties**.

## Copying and pasting into another program

You can copy the scanned image to the Clipboard and then paste it into a file in the destination program. After the image is pasted, it becomes a part of the file.

### *To copy and paste into another program*

- 1 In the HP Precisionscan Pro software, do one of the following:
  - On the **Edit** menu, click **Copy**.
  - On the toolbar, click .
- 2 In the destination program, place the cursor where you want to insert the scanned image and click.
- 3 Choose the **Paste** command in the program.

## Dragging-and-dropping into another program

You can drag-and-drop a scanned image into another program if that program supports drag-and-drop. The cursor turns to a  if you try to drop a scanned image into a program that does not support drag-and-drop, or if you drag the image over a program or area that does not support drag-and-drop.

### *To drag-and-drop into another program*

- 1 Open a file in the destination program. Make sure you can see both the destination program and the HP Precisionscan Pro software.
- 2 In the HP Precisionscan Pro software, place the cursor over the scanned image.
- 3 Click inside the selection area and drag to the location in the destination program. Then, release the mouse button. Wait for the scanner to perform a final scan of the image.

## Dragging-and-dropping to the Windows Desktop or a folder

Scanned images you drag-and-drop to the Windows Desktop or a folder in Windows Explorer become a bitmap file. The bitmap file is given a generic name such as "scan.bmp." *Subsequent images scanned to the Desktop or that folder replace the current one.* Therefore, if you want to save a scanned image, rename it before you drag-and-drop another image to that location.

### *To drag-and-drop to the Windows Desktop or a folder*

- 1 Make sure you can see both the HP Precisionscan Pro software and the Desktop or the folder you want in Windows Explorer.
- 2 In the HP Precisionscan Pro software, place the cursor over the scanned image.
- 3 Press **CTRL** and click over the selection area.
- 4 While holding down the mouse button, drag the scanned image to the Desktop or folder and release the mouse button. Wait until the scanner performs the final scan.

## Scanning to CD

The Scan to CD function is a quick, convenient way to scan and save scanned items to a rewritable CD. This feature is a helpful shortcut for people who frequently archive or store scans on CDs. To scan to a CD, you must have CD-writer hardware installed and have a rewritable CD available.

### *To scan to CD*

- 1 Start a new scan, and make any adjustments you want in using the scanning software.
- 2 In the HP Precisionscan Pro software, do one of the following:
  - On the **Scan** menu, click **Scan to CD**. On the toolbar, click  (Scan to CD).

A Save As dialog appears.

- 3 If a CD-writer drive is installed, this drive is automatically listed at the top of the dialog. If you have created folders on your CD to organize images, select the desired folder in which to save the scan.
- 4 Type in a file name.
- 5 In the **Save As Type** list, select the file type. To change the file type, select a different file type in the drop-down list.
- 6 Click **Save**.

## Other features and tips

In this section, you can find information about:

- Which settings to use to get the best image quality. (See "[Tips for best image quality](#)" on page 67.)
- How to save a group of settings and use them with future scans when you select them. (See "[Saving settings](#)" on page 68.)
- How to change the default settings the scanner uses to scan all items. (See "[Setting preferences](#)" on page 68.)
- How to start scanning from programs compliant with TWAIN. (See "[Scanning from other programs \(TWAIN\)](#)" on page 71.)
- How to scan using Windows Imaging Application (WIA). (See "[Scanning from other programs \(WIA\)](#)" on page 72.)
- How to make scanned text editable. (See "[What to expect from OCR programs](#)" on page 73.)

## Tips for best image quality

Output type, resolution, file type, and values for other controls determine image quality and file size.

When you first scan an item, the scanner chooses the defaults for output type and resolution, and you do not need to change them. If you want to change these settings or want help choosing a file type, see:

- "[To select an output type](#)" on page 43.
- "[Changing resolution](#)" on page 46.
- "[List of file types](#)" on page 63.

---

### Tip

For help choosing an output type, view the Guided Steps. If they are not already displayed, click . In step 3 "Confirm that the output type is what you want," select **Help Me Choose** from the drop-down list.

---

---

### Tip

For any image that will be printed, choose TIFF compressed as the file type to reduce the file size while maintaining quality. Also, many different programs recognize this file type.

---

## Saving settings

You can save and name a group of settings that you frequently use for a particular purpose and apply them to items you scan in the future. For example, if you routinely e-mail pictures to someone, you can save the settings including the output type, resolution, and dimensions that you always use. The settings are automatically applied when you scan a picture and choose the group of settings.

Saved settings override the default settings and any changes you made up to that point. Any changes you make after that point are preserved.

### *To save settings*

- 1 Make sure the scanned image whose settings you want to save is in the preview window and that you have adjusted any settings for the image.
- 2 On the **Scan** menu, point to **Settings**, and click **Save**. The settings for the current scanned image appear.
- 3 In the drop-down list at the bottom, type a name for these settings and click **Save**.

### *To use settings*

- 1 Scan an item to the HP Precisionscan Pro software.
- 2 On the **Scan** menu, point to **Settings**, and click **Load**.
- 3 Select the group of settings you want from the list at the bottom and click **Load**.

## Setting preferences

The preferences are the default settings for all scans performed. To change a setting only for the item currently being scanned see ["Making optional adjustments, basic" on page 45](#) and ["Making optional adjustments, advanced" on page 49](#).

### *To set scanning preferences*

- 1 On the **Scan** menu, click **Preferences**.
- 2 Click the tab you want.
- 3 Change any settings you want. See the next sections for descriptions of options on tabs.
- 4 When finished, click **OK**.

### *Scanner tab options*

The **Scanner** tab of the **Preferences** dialog box controls these options.

#### **Preview scan when the Scan To button is pushed**

When selected, a preview of the scan appears when you press the Scan To button on the scanner. When cleared, the software starts, but the scanner does not scan. You will start a scan from the HP Precisionscan Pro software.

#### **Best Quality Scaling**

When selected, the highest quality scaling is applied to the final scan. When cleared, normal quality scaling is applied, making scanning faster.

#### **Best Quality Sharpening**

When selected, the highest quality sharpening is applied to the final scan. When cleared, normal quality sharpening is applied, making scanning faster.

#### **Maximum Pixel Depth**

When selected, the largest pixel bit depth is acquired from the scanner to produce the highest quality image. When cleared, less image data is processed, making scanning faster.

#### **Noise Reduction**

When selected, reduces the noise in the image caused by the scanner. When cleared, noise reduction is not applied, making scanning faster.

#### **Enable Scan Another Page Dialog**

When selected, a dialog box appears during final scanning that asks you if there are more pages of this item to scan. When cleared, the scanner assumes each job is only one page. Applies only to .pdf, .txt, .rtf, and .html formats.

#### **Extend lamp time out**

When selected, this setting keeps the scanner lamp and the XPA light source (if it is connected) turned on beyond the default time out. This feature provides the following benefits:

- reduces scanning time by eliminating the lamp warm up that is typically required between scans
- keeps the XPA light source on beyond the default time out so you can use it as a light table for viewing 35 mm slides

When cleared, the scanner lamp and the XPA light source (if connected) time out and turn off after a period of inactivity.

### *Selection Area tab options*

The **Selection Area** tab controls the following preferences.

#### **Automatically create selection area after a mouse click**

When selected, a selection area will be created around an area on which you click with the cursor.

#### **Automatically set the Output Type after selection**

When selected, the software automatically determines the output type of the area inside the selection border.

#### **Automatically adjust exposure after selection**

When selected, the scanning software automatically changes the values in the **Adjust Exposure** or **Adjust Black and White** dialogs to the optimal values each time you create a new selection area. Values for an image do not change if you adjust the selection area while the **Adjust Exposure** or **Adjust Black and White** dialog box is open. When cleared, the scanning software does not automatically reset the controls in these two tools.

#### **Automatically adjust color after selection**

When selected, the scanning software automatically changes the values in the **Adjust Color** dialog to the optimal values each time you create a new selection area. Values never change if you create a different selection area while the **Adjust Color** dialog box is open.

When cleared, the scanning software does not automatically reset the controls.

### *Resolution tab options*

The **Resolution** tab controls the default resolution values available when you select **Change Resolution** on the **Tools** menu.

Default values are already set, but you can add custom resolution values or delete values. Two resolutions that do not appear here, 200 dpi and 300 dpi, do appear in the **Change Resolution** dialog box. These values cannot be deleted because they are the recommended values for photos and black and white images.

The range of resolution is 12 to 999,999. Click **Add** to add a value. Or, select a value and click **Delete** to delete that value.

### *Text tab options*

The **Text** tab of the **Preferences** dialog box controls the following preferences related to text output from the optical character recognition (OCR) program.

#### **Text Output (format)**

- **Framed text** places the text from the page into frames and attempts to recreate the page formatting as closely as possible to the original. The program into which the text is placed must support this type of option.
- **Flowed text** eliminates column and other formatting and inserts any images in the text as closely as possible to where they were in the original. Flowed text is easier to edit.

#### **Current OCR Language**

Allows you to choose the language the OCR program uses to check words it is processing in the item.

### *Controls tab options*

The **Controls** tab of the **Preferences** dialog box controls the control range readout to use for scanning.

The control range sets the amount of tonal resolution per color available for correction in the **Adjust Exposure** command and **Adjust Black & White** command. Using a larger number of bits for the control range results in greater control of compensation for exposure or threshold correction.

Choose one of these options:

- **8-bit readout (0-255)** — sets the controls to use 8 bits of tonal resolution per color
- **10-bit readout (0-1023)** — sets the controls to use 10 bits of tonal resolution per color
- **12-bit readout (0-4095)** — sets the controls to use 12 bits of tonal resolution per color
- **16-bit readout (0-65535)** — sets the controls to use 16 bits of tonal resolution per color

## Scanning from other programs (TWAIN)

You can bring an image directly into an open file in one of your programs if the program is TWAIN-compliant. Generally, the program is compliant if it has a command such as “Acquire,” “Scan,” or “Import New Object.” If you are unsure if the program is compliant or you do not know what the command is called, see the documentation for the program.

When scanning from within a TWAIN-compliant program, the HP Precisionscan Pro software may start if the TWAIN-program allows it. If the HP Precisionscan Pro software starts, you can make changes to the image as you normally would. If not, the image returns to the TWAIN-program immediately.

---

### Tip

If your program is not TWAIN-compliant, you can try to copy and paste or drag-and-drop the image into the program. Or, save the image as a file and then place the file in the program.

---

### To scan from other programs (TWAIN)

- 1 Start a scan from within the other program by choosing the **Acquire** (or similar) command.
- 2 If the HP Precisionscan Pro software opens and displays the preview image, create a selection area. You can crop the scan (if necessary), select the output type, and make optional adjustments as you normally would. See the appropriate sections in this chapter for instructions.
- 3 When finished making changes to the scanned image, do one of the following to perform a final scan and place it in the program from which you started scanning:
  - On the **Scan** menu, click **Return Image to**.
  - Click .

The image appears in the open program. You might have to reposition the image.

If the image does not appear, the TWAIN-compliant program might not accept the resolution or output type you selected. Rescan the image using the default settings the software sets for the image.

### Scanning from other programs (WIA)

(For Windows Me only) Windows Imaging Application (WIA) is another way to scan an image directly into an application in which you are working, such as Microsoft Word. With WIA, you are using Microsoft software to scan.

Generally, a program is WIA-compliant if it has a command such as **Picture/From Scanner or Camera** on the **Insert** or the **File** menu. If you are unsure whether the program is compliant or you do not know what the scan command is called, see the documentation for the WIA program.

### To scan from other programs (WIA)

- 1 On the **Insert** menu, point to **Picture** and then click **From Scanner or Camera**.
- 2 If you have more than one scanner or camera connected, select the scanner you want to use under **Device**.
- 3 Select the quality you want for your scan. Click **Web Quality** if you want a lower resolution so your picture can be viewed on the screen. Click **Print Quality** if you want a higher resolution for printing the picture.
- 4 Click **Insert** to scan the picture and place it into the document using predefined settings.

For more information, see the documentation for the WIA-compliant program.



## What to expect from OCR programs

Optical character recognition programs convert some text more accurately than other text. Because OCR technology is never perfect, proofread all converted text carefully to ensure the characters have been correctly interpreted.

These types of text convert most accurately:

- text in standard fonts
- text in 9-point font or larger
- crisp, clear text
- black text on a white background

These types of text might convert less accurately:

- text close to non-text elements, such as bullets, lines, or graphics
- text in spreadsheets, tables, or forms
- letters that have gaps, that “bleed” along their edges, or that touch other letters
- underlined text
- text on colored paper

Handwriting cannot be converted.



# 4 Using accessories

Some scanners support using the HP Scanjet Automatic Document Feeder (ADF) and the HP Scanjet Transparency Adapter (XPA) for scanning slides and negatives. (Some models only, see the ["Front panel and accessories comparisons"](#) on page 3.)

## Scanning from the ADF

You can scan multiple-page items quickly and easily using the ADF. When you use the ADF, you can scan to the HP Precisionscan Pro software or other destinations. For instructions about setting up the ADF, see the [Setup and Support Guide](#). For information about preparing items for the ADF, see "Items for the ADF" on page 16.

### To scan from the ADF

- 1 Place a stack of similarly sized originals in the document input tray, face up with the first page on top.

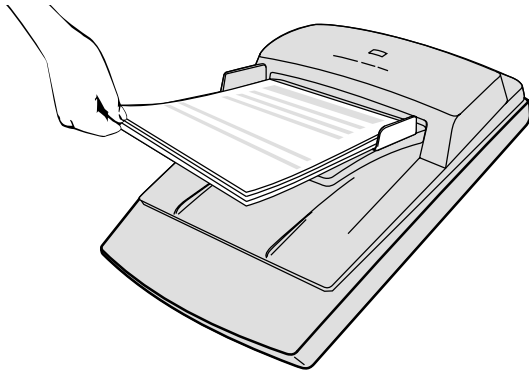

- 2 Adjust the paper guides to center the stack.

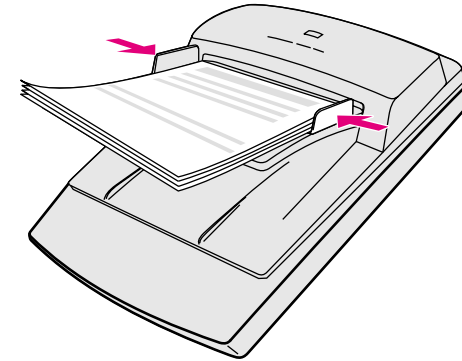

- 3 Do one of the following:
  - Start the HP Precisionscan Pro software and follow the directions on the computer screen.
  - Press a button on the front of the scanner.
 If you start the scan from the HP Precisionscan Pro software or scan to the HP Precisionscan Pro software using the Scan To button (  ):
  - a The **ADF Scan** dialog box opens and displays the current output type, resolution, and page size, which you can change. Or, you can click **Load Settings** and choose settings you have preset.
  - b To scan the item to a file, click **Scan**. Or, to scan directly to a destination, click **Scan To**, select a destination, and click **Scan**.

If you start the scan from any scanner button *except* the Scan To button, follow the directions on the screen to complete the scan.

## Scanning from the XPA

You can scan 35 mm slides or negatives using the XPA.

---

**Tip** Do not use the XPA to scan a letter-size item, such as a presentation transparency. Place the transparent item on the scanner glass, place a white piece of paper on top, and scan as you normally would using the **Scanner Glass** command on the **Scan** menu.

---

See the [Setup and Support Guide](#) for information about installing the XPA.

See ["Items for the XPA"](#) on page 16 for information about preparing items for the XPA.

## Scanning slides

To scan standard 35 mm slides, use the XPA light source and the positioning plate. When scanning fewer than three slides, you also need the slide light shield.

### *To scan slides*

- 1 With the XPA light source connected to its port on the scanner, restart the software.
- 2 Place the positioning plate on the scanner glass so the arrow is in the upper right-hand corner. Push the positioning plate toward the top right corner.

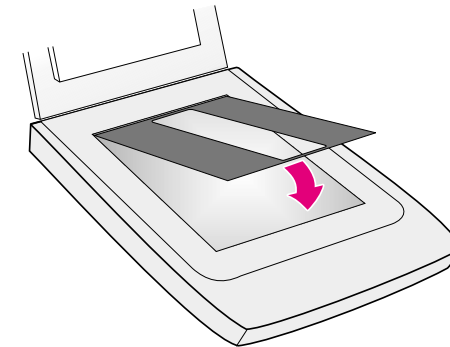

- Slide up to three slides into the slide holder on the bottom side of the XPA light source. Slides should be right-side facing you.

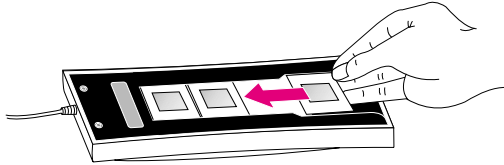

**Tip** The XPA light source also functions as a light table for viewing 35 mm slides. Insert slides as shown above. To keep the XPA light source on beyond the default period, select the **Extend lamp time out** setting in the HP Precisionscan Pro software. See "[Setting preferences](#)" on page 68.

- If you are scanning fewer than three slides, insert the slide light shield after you load your last slide.
- Place the XPA light source into the positioning plate with slides facing down and the HP logo facing you.

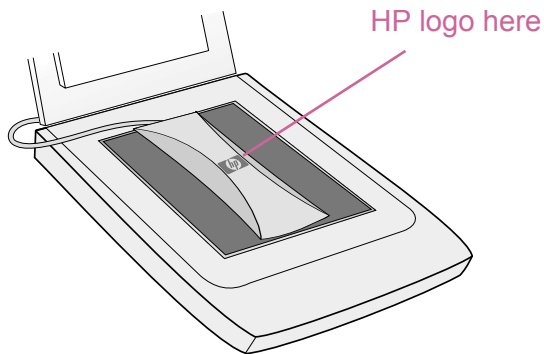

- From the HP Precisionscan Pro software, click the **Scan** menu, and select **XPA (Slides)**.
- Before making any changes, see "[Making optional adjustments for slides or negatives](#)" on page 81.
- When you have finished using the XPA light source, on the **Scan** menu, click **Scanner Glass**. Disconnect the XPA light source if you want.

## Scanning negatives

To scan 35 mm negatives, use the XPA light source, the positioning plate, and the negative holder. When scanning fewer than four negative frames, you also need the negative light shield.

### To scan negatives

- 1 With the XPA light source connected to its port on the scanner, restart the software.
- 2 Place the positioning plate on the scanner glass so the arrow is in the upper right-hand corner. Push the positioning plate toward the top right corner.

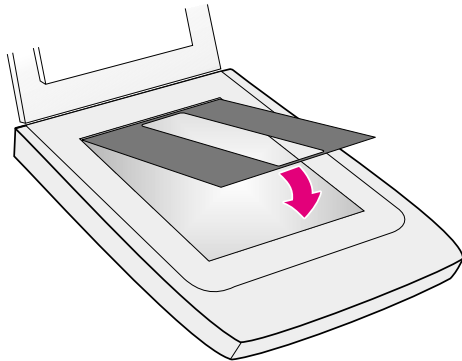

- 3 Slide the strip of negatives into the negative holder. If the negative strip curves, the curve should be facing out toward you.

**CAUTION** Negatives are easily damaged. Touch them only on the edges.

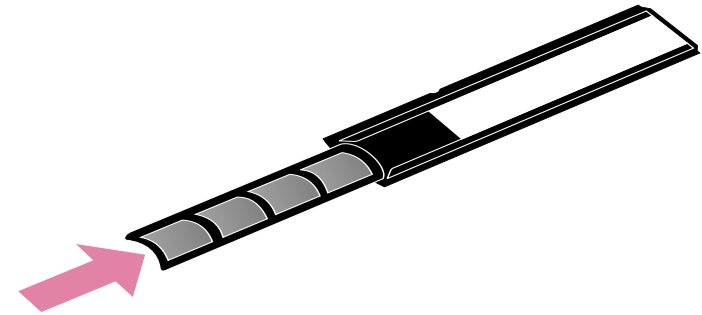

- 4 If you are scanning a strip of negatives with fewer than four frames, insert the negative light shield after the negative strip. See the icon on the negative holder for assistance.
- 5 Slide the negative holder into the slide holder on the bottom side of the XPA light source.

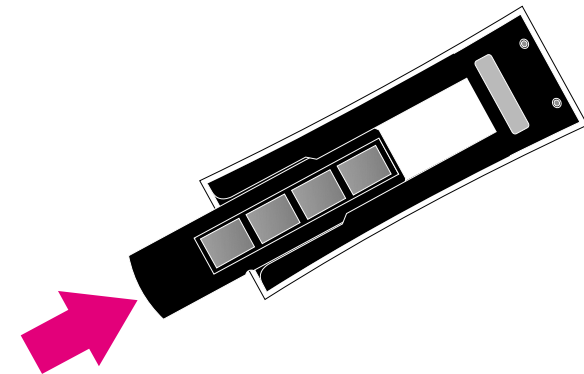

- 6 Place the XPA light source into the positioning plate with negatives facing down and the HP logo facing you.

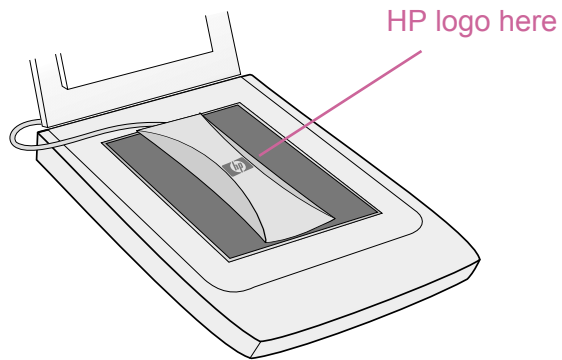

- 7 From the HP PrecisionScan Pro software, click the **Scan** menu, and select **XPA (Negatives)**.
- 8 Before making changes, see ["Making optional adjustments for slides or negatives" on page 81](#).
- 9 When finished using the XPA light source, on the **Scan** menu, click **Scanner Glass**. Disconnect the XPA light source if you want.



## Making optional adjustments for slides or negatives

You can make optional adjustments to slides or negatives scanned using the XPA. *Before deciding to make adjustments, create a selection area around one slide or negative so the software exposes it correctly.* See ["Cropping or selecting an area for final scan" on page 42](#).

If you choose to make adjustments to the image after you create a selection area, make most of them as you normally would, except for the following adjustments:

- Midtone. See ["Adjusting midtones for slides or negatives" on page 81](#).
- Highlight. See ["Adjusting highlights for slides or negatives" on page 82](#).
- Shadow. See ["Adjusting shadows for slides or negatives" on page 82](#).
- RGB values and pixel color. See ["Viewing RGB values and pixel color" on page 83](#).

---

**Tip** See ["Making optional adjustments, basic" on page 45](#) and ["Making optional adjustments, advanced" on page 49](#) to make all adjustments except the ones mentioned above.

---

---

**Tip** To enlarge a slide or negative, see ["Resizing \(output dimensions\)" on page 45](#).

---

## Adjusting midtones for slides or negatives

You can adjust the overall lightness or darkness of the scanned image using the midtone setting. The range for the number in the **Midtone** field is -100 to 100.

### *To lighten slides or negatives overall*

- 1 On the **Advanced** menu, click **Adjust Exposure**.
- 2 Do one of the following:
  - Drag the Midtone slider to the right.
  - Type a higher number in the **Midtone** field and press **ENTER**.

### *To darken slides or negatives overall*

- 1 On the **Advanced** menu, click **Adjust Exposure**.
- 2 Do one of the following:
  - Drag the Midtone slider to the left.
  - Type a lower number in the **Midtone** field and press **ENTER**.

### *To return to the default settings*

- 1 On the **Advanced** menu, click **Adjust Exposure**.
- 2 Click **Auto** to return the midtone, highlight, and shadow settings to the defaults for this slide or negative.

## Adjusting highlights for slides or negatives

You can adjust highlights to lighten or darken the light areas. The range for the number in the **Highlights** field is -100 to 100.

### *To lighten lighter areas*

- 1 On the **Advanced** menu, click **Adjust Exposure**.
- 2 Do one of the following:
  - Drag the Highlight slider to the right.
  - Type a higher number in the **Highlights** field and press **ENTER**.

### *To darken lighter areas*

- 1 On the **Advanced** menu, click **Adjust Exposure**.
- 2 Do one of the following:
  - Drag the Highlight slider to the left.
  - Type a lower number in the **Highlights** field and press **ENTER**.

### *To return to the default settings*

- 1 On the **Advanced** menu, click **Adjust Exposure**.
- 2 Click **Auto** to return the midtone, highlight, and shadow settings to the defaults for this slide or negative.

## Adjusting shadows for slides or negatives

You can adjust shadows to lighten or darken the dark areas. The range for the number in the **Shadows** field is -100 to 100.

### *To lighten darker areas*

- 1 On the **Advanced** menu, click **Adjust Exposure**.
- 2 Do one of the following:
  - Drag the Shadow slider to the right.
  - Type a higher number in the **Shadows** field and press **ENTER**.

### *To darken darker areas*

- 1 On the **Advanced** menu, click **Adjust Exposure**.
- 2 Do one of the following:
  - Drag the Shadow slider to the left.
  - Type a lower number in the **Shadows** field and press **ENTER**.



### *To return to the default settings*

- 1 On the **Advanced** menu, click **Adjust Exposure**.
- 2 Click **Auto** to return the midtone, highlight, and shadow settings to the defaults for this slide or negative.

## Viewing RGB values and pixel color

You can view the RGB values and pixel color for any spot in an image, color or grayscale, using the RGB Meter.

*To view RGB values and pixel color*

- 1 On the **Advanced** menu, click **Adjust Exposure**.
- 2 Click . The cursor changes to an eyedropper.
- 3 Move the cursor over the area in the item for which you want to see the values. The values appear in the RGB area. A line appears in the histogram to show you where those pixels occur.
- 4 When finished, click  again.



# 5 Troubleshooting and maintaining

This section provides information for:

- Solving issues that might occur while using the scanner or HP scanning software, or issues with the appearance of scanned images. Start with ["Checking the basics" on page 85](#).
- Clearing jams from the ADF. See ["Clearing jams from the ADF" on page 102](#).
- Cleaning and maintaining the scanner and accessories. See ["Cleaning and maintaining" on page 105](#).

See the [Setup and Support Guide](#) for installation and troubleshooting information.

## Checking the basics

If the scanner is not working, always perform these actions first.

- Check that the power cable is securely connected between the scanner and a live electrical outlet or surge protector.
- If the power cable is connected to a surge protector, make sure the surge protector is plugged into an outlet and turned on.
- Check that the interface cable is securely connected between the scanner and the computer.
- Make sure the scanner is unlocked. Move the lock to the unlocked position. (Some models only, see ["Front panel and accessories comparisons" on page 3](#).)
- Disconnect the power cable from the scanner and turn off the computer. After 30 seconds, reconnect the power cable to the scanner and then turn on the computer, in that order.
- If a program has frozen, close it. Press **CTRL+ALT+DELETE** to open Close Programs or Task Manager. Select any program listed as Not Responding and click **End Task**.

If these steps did not resolve the issue, see ["Starting troubleshooting" on page 86](#).

## Starting troubleshooting

Start here to find the information you need. Choose one of these general groups of issues, and then choose one of that group's more specific issues.

*The scanner or software is not working.*

- A message is on the scanner or the computer. Follow the directions in the message to resolve the issue.
- There is no message. See ["Resolving issues that did not generate messages" on page 87](#).
- There is an error message on the front panel liquid crystal display (LCD). See ["Resolving scanner messages" on page 87](#).

*The quality of resulting scans is not what I expected.*

- Scanned images do not look good. See ["Resolving issues with scanned images" on page 91](#).
- Printed copies do not look good. See ["Resolving issues with printed copies" on page 93](#).
- Text on images is not editable. See ["Resolving issues with editable text" on page 96](#).
- Slides or negatives do not look good. See ["Resolving issues with slides and negatives" on page 95](#).

*Scans are not arriving at the destination I choose.*

See ["Resolving issues sending to destinations" on page 97](#).

*I am having an issue with the HP Scanjet Transparency Adapter (XPA) or the HP Scanjet Automatic Document Feeder (ADF).*

- Pages are jammed in the ADF. See ["Clearing jams from the ADF" on page 102](#).
- There is an issue with the ADF, other than pages jamming. See ["Resolving issues with the ADF" on page 101](#).
- There is an issue with the XPA. See ["Resolving issues with the XPA" on page 100](#).

## Resolving scanner messages

(Some models only, see "Front panel and accessories comparisons" on page 3.) If an error message appears on the 16-character front panel LCD display on your scanner, look for the cause and solution in this section.

### ADF Paper Jam

Pages are jammed in the ADF. See "Clearing jams from the ADF" on page 102 for information on clearing paper jams from the ADF.

Clear the paper jam. If the error message does not clear, unplug the scanner and plug it back in.

### Error ##

The scanner reported an error during the self-test.

Unplug the scanner and plug it back in. If this error message is still on the scanner, contact HP support. Visit the HP support website at:

<http://www.hp.com/go/support>

See the [Setup and Support Guide](#) for phone contact information.

### Scanner Locked

(Some models only, see the "Front panel and accessories comparisons" on page 3.) The scanner is not working because it is locked. Make sure the scanner is unlocked. Move the lock to the unlocked position. If the error message does not clear, unplug the scanner and plug it back in.

## Resolving issues that did not generate messages

If the scanner or software is not working but no message appears, look for the cause and solution in this section.

### Items you scanned previously are no longer on the computer.

The scanned image might not have been saved as a file. If you send an image directly to a destination, the scanned image is not saved on the computer. When you use HP Precisionscan Pro to scan, use **Save As** to save the image to your computer.

### The scanner lamp stays on.

The scanner lamp should time out and turn off automatically after a period of inactivity.

- If you have recently used the scanner, wait a few more minutes.
- If the scanner lamp is still on, you might have activated the **Extend lamp time out** feature. Check this setting on the **Scanner** tab in the Preferences of the HP Precisionscan Pro software. See "Setting preferences" on page 68.
- Press the Power Save button on the front panel of the scanner to immediately turn off the scanner lamp and the XPA light source (if connected). See "General tab options" on page 37.

If you still encounter problems with the scanner lamp or the Power Save button, contact HP Customer Support. (See "Contacting HP Customer Support" in the [Setup and Support Guide](#).)

I saved a scanned image to a file, but now I cannot open the file in the program I want.

You might have saved the file in a format the other program cannot use. Save the file in a different format the program can use. Look in the **File Open** or **Import** command for the program to see which file types it supports.

The scanner is not working.

One or more of these issues might be causing the problem:

- The scanner was not installed properly.
- The interface cable is not compatible with the scanner.
- A cable might be loose. Check that the interface cable is securely connected.
- If the scanner is emitting a grinding sound, the scanner is locked.

See "[Checking the basics](#)" on page 85, and the [Setup and Support Guide](#) for installation and troubleshooting information.

The scanner does not scan right away.

If the scanner has not been used for a while, the scanner lamp has turned itself off. The lamp goes through a warm-up period after you start the software, or press the Scan To button. Wait for a few seconds for scanning to begin.

When I press a button on the scanner, the incorrect program opens.

Check which function is set to open when you press the button on the scanner:

**In Windows 98 and 2000:**

- 1 On the **Start** menu, point to **Settings**, and click **Control Panel**.
- 2 Double-click **Scanners and Cameras**. Select your scanner model number from the list if it is not already selected.
- 3 Click **Properties**.
- 4 From the **Scanner Events** list, select the name of the button you want to check. Verify what function is set for this button.

**In Windows Me:**

- 1 On the **Start** menu, point to **Settings**, and click **Control Panel**.
- 2 Double-click **Scanners and Cameras**. Double-click the icon next to the name of your scanning device.
- 3 Click **Properties**.
- 4 From the **Scanner Events** list, select the name of the button you want to check. Verify what function is set for this button.

**In Windows NT 4.0 and Windows 95:**

- 1 On the **Start** menu, point to **Programs**, point to **HP Scanjet Utilities**, and click **HP Scanjet Button Manager**.
- 2 Click the **Events** tab.
- 3 From the **Scanner Events** list, select the name of the button you want to check. Verify what function is set for this button.



When I choose **Scan To** on the scanner, the image does not appear in the software.

- A cable might be loose. Check that the interface cable is securely connected.
- You might have accidentally turned off the preview feature. Check this setting on the **Scanner** tab in the Preferences of the HP Precisionscan Pro software. See "[Setting preferences](#)" on page 68.
- (Some models only, see the "[Front panel and accessories comparisons](#)" on page 3.) Check that the HP Precisionscan software is the program set to start when you press the Scan To button (  ) using the following steps.

#### In Windows 98 and 2000:

- 1 On the **Start** menu, point to **Settings**, and click **Control Panel**.
- 2 Double-click **Scanners and Cameras**. Select your scanner model number from the list if it is not already selected.
- 3 Click **Properties**.
- 4 From the **Scanner Events** list, select the **Scan To** button.
- 5 Make sure the **HP Precisionscan Pro** check box is checked.
- 6 Make sure the **Disable Device Events** check box is unchecked.

#### In Windows Me:

- 1 On the **Start** menu, point to **Settings**, and click **Control Panel**.
- 2 Double-click **Scanners and Cameras**. Double-click the icon next to the name of your scanning device.
- 3 Click **Properties**.
- 4 From the **Scanner Events** list, select the **Scan To** button.
- 5 Under **Actions**, make sure that **HP Precisionscan Pro** is selected next to **Start This Program**.
- 6 Verify that the **Take No Action** check box is unchecked.

#### In Windows NT 4.0 and Windows 95:

- 1 On the **Start** menu, point to **Programs**, point to **HP Scanjet Utilities**, and click **HP Scanjet Button Manager**.
- 2 Click the **Events** tab.
- 3 From the **Scanner Events** list, select the **Scan To** button.
- 4 Make sure the **HP Precisionscan Pro** check box is checked.
- 5 Make sure the **Disable Events** check box is unchecked.

#### Scanner is scanning items very slowly.

- If you are scanning to edit text, the optical character recognition (OCR) program causes the scanner to scan more slowly, which is normal. Wait for the item to scan.
- Some default settings can cause the scanner to scan more slowly. Check the settings. See "[Setting preferences](#)" on page 68.
- The resolution might be set too high. Return to the default resolution. See "[Changing resolution](#)" on page 46.

#### The correct menu items do not appear in the HP Precisionscan Pro software.

- If you used the ADF and then disconnected it, restart the software.
- If you were using the XPA, on the **Scan** menu, click **Scanner Glass** to scan from the glass again.
- If you are trying to use the XPA and the **XPA (Slides)** or **XPA (Negatives)** commands are unavailable, restart the software while the XPA light source is connected to the scanner.

The scanner is making a loud clicking or grinding noise.

The scanner is locked. Move the lock to the unlocked position. (Some models only, see the "Front panel and accessories comparisons" on page 3.)

The online Help or the Guided Steps in the HP Precisionscan Pro software do not work.

Help is available for computers running Internet Explorer version 4.0 or greater. You can install a newer version of Internet Explorer, or you can view the Online User's Manual for assistance.

**To view the Online User's Manual:**

In the HP Precisionscan Pro software, point to the **Help** menu, and click **User's Manual**. Or, click the **Help** button in any dialog box in which it appears.

## Resolving image-quality issues

This section contains information for resolving image-quality issues, whether you scanned using the scanner glass, the ADF, or the XPA.

- "Resolving issues with scanned images" on page 91.
- "Resolving issues with printed copies" on page 93.
- "Resolving issues with slides and negatives" on page 95.

---

### Tip

For help getting the best output type possible, use the Guided Steps. If they are not showing, click .

---

## Resolving issues with scanned images

This section contains solutions to issues that affect all scanned images, regardless of whether you used the scanner glass or the ADF. If you were printing, see also ["Resolving issues with printed copies"](#) on page 93.

Scanned images are too light or too dark.



The original image might be very light or dark or be printed on colored paper. Adjust the midtone, highlight, and shadow settings from the HP Precisionscan Pro software. See ["Scanning from HP Precisionscan Pro"](#) on page 39.

Scanned images have black dots or streaks in top and bottom margins.



There might be ink, glue, correction fluid, or some other substance on the scanner glass. Clean the scanner glass. See ["Cleaning the scanner glass"](#) on page 105.

Scanned images have unwanted lines through them.



- The scanner glass might be dirty. Clean the glass. See ["Cleaning the scanner glass"](#) on page 105.
- If you are using the ADF, the ADF glass might be dirty or scratched. Clean the ADF glass. See ["Cleaning the ADF glass"](#) on page 106.

Scanned image is not clear.



- The resolution, sharpening, or midtone, highlight, and shadow settings might need to be adjusted before scanning. See ["Scanning from HP Precisionscan Pro"](#) on page 39.
- The original might be on colored paper. If the original was printed on a colored paper, including brown recycled paper, the image or text might not be clear. Try adjusting the resolution and midtone, highlight, and shadow settings from the HP Precisionscan Pro software. See ["Scanning from HP Precisionscan Pro"](#) on page 39.

### The image is completely black or completely white.

The item might not be placed correctly on the scanner glass or in the ADF. Make sure that the item you are trying to scan is placed face down on the glass, or face up in the ADF.

### Colors in the scanned image are different from the original item.

Scanners, monitors, printers, and different operating systems interpret color differently. Use the hue and saturation settings in the HP Precisionscan Pro software to adjust the colors.

### In the HP Precisionscan Pro software, all of the image scanned when I only wanted part, or vice versa.

The selection area might not be selected correctly. Make sure the selection border is surrounding the area you want in the final scan.

### Scanned images are crooked.

The item might have been placed crookedly or shifted when you closed the lid. Straighten the original on the scanner glass and scan again.

### I thought I made the image smaller or larger before the final scan in the HP Precisionscan Pro software, but it is still the same size as the original.

You might have zoomed in or out, which does not change the size of the image. Change the output size. See ["Resizing \(output dimensions\)" on page 45](#).

### An original photo was fuzzy, and the scanned image looks even worse.

The sharpening level needs to be increased. In the HP Precisionscan Pro software, adjust the sharpening. See ["Sharpening an image" on page 48](#).

### Scanned images are grainy, jagged, or fuzzy.

- You resized the image in a program other than the HP Precisionscan Pro software. Resize the image in the HP Precisionscan Pro software before you send it to the other program. (See ["Resizing \(output dimensions\)" on page 45](#).) Or, if the original was a black and white drawing, use the Black & White Scalable output type for the scanned image. (See ["Selecting output type" on page 43](#).)
- In the HP Precisionscan Pro software, the resolution is set too low. Set the resolution to a higher number, or return to the default setting. See ["Changing resolution" on page 46](#).
- In the HP Precisionscan Pro software, too much or too little sharpening was applied. Adjust the sharpening. See ["Sharpening an image" on page 48](#).

### An original photo had marks, flaws, or scratches, and the scanned image looks even worse in the HP Precisionscan Pro software.

- You sharpened the image manually. Return to the default setting. See ["Sharpening an image" on page 48](#).
- Best Quality Sharpening is selected. Check the setting. See ["Setting preferences" on page 68](#).

### I set the image to a higher resolution in the HP Precisionscan Pro software, but the output quality is no better.

- Setting the resolution to a higher number does not necessarily improve quality. The software sets the resolution automatically based on the type of item you scanned. Keep or return to the default. See ["Changing resolution" on page 46](#) or ["Tips for best image quality" on page 67](#) for guidelines.
- If you sent the image to another program, the program might not support the resolution you set in the HP Precisionscan Pro software. Determine the setting the program uses and set the resolution in the HP Precisionscan Pro software to that resolution.

Images scanned from the HP Precisionscan Pro software are larger than the original when viewed or printed from another program, such as MS Paint, MS Internet Explorer, or MS Imaging.

The other program did not accept the image size information. Scan the image at a lower resolution. When you scan at a resolution the program accepts, it will display or print the image at the correct size.

The image is too big or too small.

In the HP Precisionscan Pro software, set the output dimensions in the **Resize** dialog box. See "[Resizing \(output dimensions\)](#)" on [page 45](#).

When I try to scan to the Web from the HP Precisionscan Pro software, the image is too large or does not look good on screen.

Scan settings for this image might be set incorrectly. Use the Guided Steps for help choosing an output type. See also "[Tips for best image quality](#)" on [page 67](#).

## Resolving issues with printed copies

Use this section to help resolve issues with printed pages.

Parts of the page around the edges are not printing.



Printers cannot print right up to the edge of the paper. To get the image to fit inside the printable area, you must slightly reduce the size of the image in the HP Precisionscan Pro software and then reprint the image.

## Copies are too light.

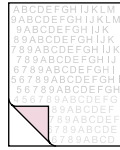

- If you are copying an item printed on colored paper, there might not be enough contrast between the ink and paper colors. Adjust the highlights, shadows, midtones, and resolution settings from the HP Precisionscan Pro software. See ["Scanning from HP Precisionscan Pro" on page 39](#). Or, adjust the contrast from the HP Scanjet Copy Utility. Also, if possible for text, use originals printed with black ink on white paper.
- The printer might be out of toner or ink. Print a different file from another program to the printer to see if the issue lies with the printer.

## Vertical white stripes appear on the page.

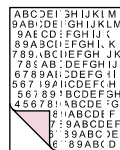

- The printer might be out of toner or ink. Print a different file from another program to the printer to see if the issue lies with the printer.
- The scanner internal mirror might be contaminated. Contact the Customer Service Center for service.

## The bottom of the printed page is blank, or part of a graphic is cut off.



The page might be too complex. (The printer does not have enough memory to process the page.) Set the resolution of the image to 300 dpi or less in the HP Precisionscan Pro software. See ["Changing resolution" on page 46](#).

## Colors in printed images are incorrect.

The output type or printer settings might not be correct. Choose a different output type and print again. Check the printer settings. If it is a color printer, check if the printer is out of ink or toner.

## Scanned images are jagged or fuzzy.

- The output type in the HP Precisionscan Pro software might not be set correctly. Set the output type to True Color (16.7 million colors) or Grayscale. See ["Selecting output type" on page 43](#).
- If you placed the image in a file in another program, resized the image, and are printing from that program, resizing the image in the program probably caused the issue. Resize in the HP Precisionscan Pro software before placing it in a file in another program. See ["Resizing \(output dimensions\)" on page 45](#).
- If the original image was fuzzy and you enlarged it, the fuzziness becomes more obvious.

## Resolving issues with slides and negatives

Use the following section to help resolve issues with slides or negatives scanned using the XPA. All actions must be performed in the HP Precisionscan Pro software, because you must scan slides or negatives using this software. See also ["Resolving issues with the XPA" on page 100](#).

[I tried to enlarge a scanned image of a slide, but the image remained the same size.](#)

You might have used the **Zoom In** command, which only changes the view on the screen. Use the **Resize** command to change the size of the final scanned image. See ["Resizing \(output dimensions\)" on page 45](#).

[The colors are incorrect, or the image is too light or too dark.](#)

- The software might be setting exposure for the entire area instead of one slide or negative. Create a selection area around the slide or negative you want to use to ensure it is exposed correctly.
- The positioning plate is not placed completely on the scanner glass. Make sure the positioning plate is completely on the scanner glass.
- If you are scanning fewer than three slides with the XPA, make sure to use the slide light shield to cover the remaining area in the slide holder. This ensures that no extra light leaks out into the scan.
- If you are scanning fewer than four negative frames with the XPA, make sure to use the negative light shield to cover the remaining area in the negative holder. This ensures that no extra light leaks out into the scan.

[The scanned image shows a colored tint, usually pink.](#)

The image was probably scanned without the XPA, or the positioning plate and XPA light source were placed incorrectly on the scanner bed. For the steps for scanning 35 mm slides or negatives, see ["Scanning from the XPA" on page 77](#).

[Scanned images appear as a box with multi-colored vertical lines or as a dashed box with an arrow surrounding the area.](#)

The positioning plate might be placed incorrectly on the scanner bed. Place the positioning plate on the scanner glass so the Hewlett-Packard logo is at the bottom right.

[The scanned image is black even though the light on the XPA light source is on.](#)

- The positioning plate might be placed incorrectly on the scanner bed. Place the positioning plate on the scanner glass so the Hewlett-Packard logo is at the bottom right.
- Check the **Adjust Exposure** command in the **Advanced** menu.

[There are streaks in the scanned image.](#)

- Check the original slide or negative for damage.
- The XPA may be broken, and service may be required.

[The scans are dark.](#)

The bulb in the XPA light source might be broken or not working. If the bulb is broken, service is required.

## Resolving issues with editable text

This section contains resolutions to issues that might occur when you are trying to make text editable.

### Scanned text is not editable.

If you used the HP Precisionscan Pro software, the software might have identified the text as a drawing. In the software, choose **Editable Text (OCR)** or **Text and Image** on the **Output Type** menu. Then, on the **Scan** menu, click **Scan To** and choose the program you want. If the text is still not editable, work with the text as an image or retype it.

### Scanned text is editable in some programs but not in others.

Some programs accept only image formats and do not allow text. Make sure the program accepts editable text.

### Incorrect characters appear in the text that was converted using the OCR software.

The accuracy of the OCR program depends on the program having the correct settings on the quality of the original item. To obtain the best possible results, choose the scan setting for text, and process only crisp, clear text. See "[What to expect from OCR programs](#)" on page 73.

### Converted text does not appear in my word-processing program.

If you scanned to the HP Precisionscan Pro software, choose **Editable Text (OCR)** or **Text and Image** on the **Output Type** menu. Then, on the **Scan** menu, click **Scan To** and choose the program you want. Or, cut and paste the text into the program you want. If the text is still not editable, work with the text as an image or retype it.

### I do not know how to process text using a different OCR program.

Do one of the following:

- Scan the item to the HP Precisionscan Pro software, save the scanned image as an image file, and open the file in the other OCR program.
- Scan to the HP Precisionscan Pro software. Then, on the **Scan** menu, click **Scan To** and choose the other OCR program.

### The converted text did not retain font size and style when the text was placed in a word-processing program.

Word-processing programs cannot always accept the original formatting of the scanned text. Reformat the text in the word-processing program.

### Converted text appeared in the word-processing program without its formatting and I wanted it, or vice versa.

Even if you want to retain the formatting and you have the setting set correctly, the receiving word-processing program cannot always accept the formatting. Reformat text in the word-processing program.



After I scan using Text or Text and Image output type, some of the text displays as squares or unrecognizable characters.

This is due to the display capability of your Microsoft Windows operating system. For example, the English version of Windows 95 cannot properly display Russian, Turkish, Simplified Chinese, Traditional Chinese, Korean, and potentially other non-western European languages. Windows 2000 is able to display all languages.

## Resolving issues sending to destinations

Use this section to resolve issues sending images to destinations. Not all functions are available on all scanners.

When I choose E-mail on the scanner, scanned images do not automatically appear in a new e-mail message.

The e-mail program is Web-based or might not be supported. Save the scanned image as a file and attach it to your e-mail message as you normally do.

When I choose E-mail on the scanner, the scanned image attaches as a bitmap, but it contains text I want the recipient to be able to edit.

To make text editable for a recipient, scan the item to the HP PrecisionScan Pro software and change the output type for the scanned image to **Editable Text (OCR)**. Then, on the **Scan** menu, click **Scan To** and select the e-mail program. Or, save the scanned image as a text file and attach it to a message as you normally do.

When I press the E-mail button on the scanner, the incorrect e-mail program opens.

- Check which e-mail program is set to open when you press the E-mail button () on the scanner. See "[Changing settings for buttons](#)" on page 34.
- If you use Outlook, Outlook Express, or Netscape Mail, make sure the program is set as your default MAPI application. If you are not sure, see the documentation for your e-mail program.

When printing copies from the scanner or the HP Scanjet Copy Utility, I cannot choose the printer I want.

Scan the item to the HP Precisionscan Pro software and print from there.

When printing copies, I can only make multiple copies of one page at a time (I cannot collate copy).

Even if you are using an ADF, each page is treated as a separate job. You can make multiple copies of one page, but not multiple copies of different pages and collate them.

When I try to print from the HP Precisionscan Pro software, the Print command is unavailable.

If the **Editable Text (OCR)**, **Text and Image**, or **Black & White Scalable** output type is selected, the **Print** command is unavailable. Choose a different output type and then print.

When I choose the Scan To button on the scanner, the image does not appear in the software.

- A cable might be loose. Check that the interface cable is securely connected.
- You might have accidentally turned off the preview feature. Check this setting on the **Scanner** tab in the Preferences of the HP Precisionscan Pro software. See "[Setting preferences](#)" on [page 68](#).
- Check that the HP Precisionscan Pro software is the program set to start when you press the Scan To button (  ). See "[When I choose Scan To on the scanner, the image does not appear in the software.](#)" on [page 89](#) for steps.

I tried to scan an image into an existing file, but the scanned image appeared in a new file instead.

Some programs only allow scanned images to be placed in new files. Cut and paste the image into the file you want. Or, save the scanned image as a file and import it into the other program.

When I try to send a scanned image using the Scan To command on the Scan menu of the HP Precisionscan Pro software, the program I want does not appear.

The HP Precisionscan Pro software might not recognize the program as a destination. Do one of the following:

- Save the scanned image in a file type the other program uses, and then open the file in the other program.
- Copy and paste or drag-and-drop the image into the other program.
- Reinstall the program that is not being recognized. This might allow the HP Precisionscan Pro software to recognize it.

I want to start scanning from another program, such as my word-processing program, so I can bring an image into my open file, but I cannot start the scan.

The other program must be TWAIN or Windows Imaging Application (WIA)-compliant. If you cannot find a command such as **Acquire** or **Insert**, check the documentation for the program to see if it is compliant. If not, do one of the following in the HP Precisionscan Pro software:

- Save the scanned image as a file and then insert the file into the other program.
- Click **Scan To** from the **Scan** menu, and choose a program.
- Copy and paste or drag-and-drop the image into the other program.

I am trying to return a scanned image to my TWAIN or WIA-compliant program, but the image will not appear.

The TWAIN or WIA-compliant program might not accept the resolution or output type you selected. Rescan the image using the default settings the HP Precisionscan Pro software sets for the image.

I do not see the destinations I want when I use the Select Destination button next to the Scan To button.

(Some models only, see the "Front panel and accessories comparisons" on page 3.)

Not all destinations appear in the scanner's destination list. For example, printers, e-mail programs, and saving to a file are not included. The list is also limited to the first 18 destinations found by the HP scanning software. You can access additional destinations through the HP Precisionscan Pro software. See "To send to a program" on page 61 for more information, or do one of the following.

- Update the destinations for your scanner buttons. See "To change settings for buttons or update destinations" on page 34 for steps.
- Unplug the scanner and plug it back in.

## Resolving issues with accessories

This section contains information for resolving issues when you are using the XPA or ADF.

### Resolving issues with the XPA

This section contains issues that might occur when you are using the XPA (transparency adapter). See also "[Resolving issues with slides and negatives](#)" on page 95.

#### The XPA is not working at all.

The XPA cable might not be connected correctly. Make sure the XPA cable is connected securely to the XPA port on the scanner.

#### When using the XPA, I cannot choose XPA (Slides) or XPA (Negatives) on the Scan menu.

- The XPA cable might not be connected correctly. Make sure the XPA cable is connected securely to the XPA port on the scanner.
- If you connected the XPA light source while the HP Precisionscan Pro software was running, restart the software. Doing so allows the software to detect the XPA.

#### When using the XPA, I cannot scan using the scanner buttons.

The XPA is not designed to work with the scanner buttons. Use the HP Precisionscan Pro software when using the XPA.

#### There is no light or only a dim light in the transparency adapter after checking XPA (Slides) or XPA (Negatives) in the Scan menu.

- Make sure you have selected **XPA (Slides)** or **XPA (Negatives)** from the Scan menu in the HP Precisionscan Pro software. If these two commands are unavailable, restart the software while the XPA light source is connected to the scanner.
- The bulb in the XPA light source might be broken or not working. With the XPA light source connected to the scanner, hold the XPA light source up and look for illumination. If the bulb is broken, service is required.

## Resolving issues with the ADF

This section contains issues that might occur when you are using the automatic document feeder (ADF).

### The ADF is feeding multiple sheets, skewing pages, or jamming frequently.

- If the pages look like they are skewing as they feed into the ADF, check the resulting scanned images in the software to ensure they are not skewed.
- The item might not be placed correctly. Straighten the item and adjust the paper guides to center the stack.
- The maximum number of pages the ADF input tray and output bin can hold is 25, depending on the type of media being loaded. Make sure to load only 25 or fewer pages in the input tray, and remove pages from the output bin if they are stacking up to a pile of more than 25.
- The item loaded might not meet the specifications for the ADF. Make sure the type of media being loaded meets required specifications. See ["Items for the ADF" on page 16](#).

### When using the ADF, the scanner does not feed the item at all.

The hatch might not be securely latched. Open the hatch, and then close it pressing firmly. See ["Clearing jams from the ADF" on page 102](#) for illustrations.

### An item loaded in the ADF keeps jamming.

- The item does not meet the guidelines for the ADF. See ["Items for the ADF" on page 16](#).
- The item might have something on it. Make sure you have removed anything such as staples and self-adhesive notes on the item. See ["Selecting and preparing items" on page 15](#).
- The item is too small. The ADF can handle items as small as 88.9 by 127 mm (3.5 by 5.0 inches). Use the glass to scan.
- The item is too large. The ADF can handle items as large as 216 by 355.6 mm (8.5 by 14 inches). Use the glass to scan the item in sections.

### The bottom of the scanned image is cut off.

- The ADF can handle items up to 355.6 mm (14 inches) long. If the item is longer, scan it in sections on the glass. If the item is the correct length, choose the correct page size setting in the ADF dialog box prompt before scanning.
- If sent to a printer, the item might be too complex (require too much memory) for the printer to process. If possible, choose a printer with more memory. Or, select a lower resolution or different output type, like black and white or grayscale.

## Clearing jams from the ADF

Pages can jam at the beginning or the end of a page. Use the appropriate procedure below to clear the jam and continue.

*To clear jams at the start of a page*

- 1 Raise the hatch.

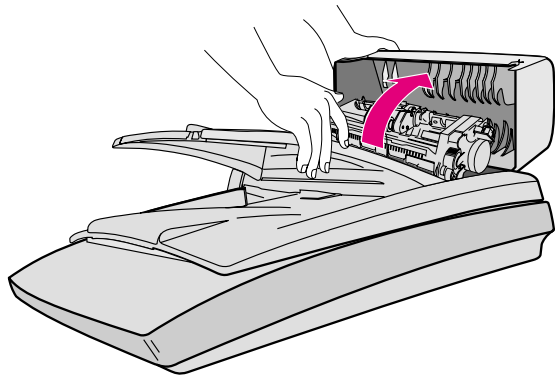

- 2 Lift the large green tab (located to the left of the roller) and gently remove the jammed page.

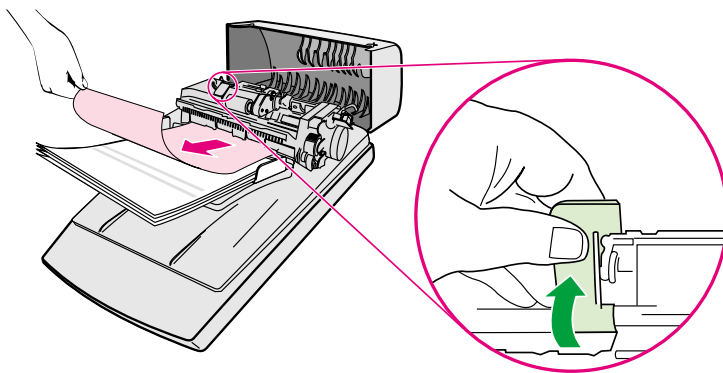

- 3 If the item cannot be easily removed, lift the two green tabs located behind the rollers and gently remove the green paper lead as shown.

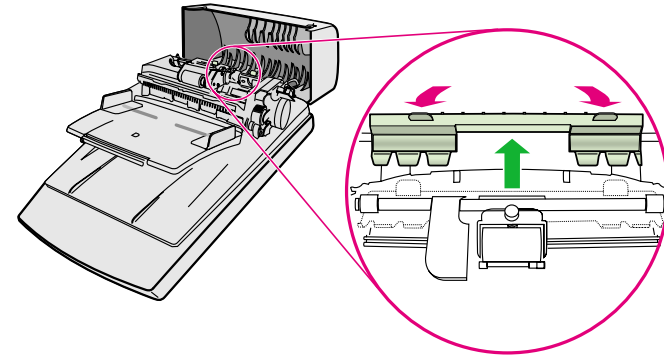

**Note:** Using force to remove the page might cause damage to your originals. If the majority of the paper is already through the main roller, use the procedure to clear jams at the end of a page.

- 4 Remove the jammed item from the ADF and replace the paper lead.

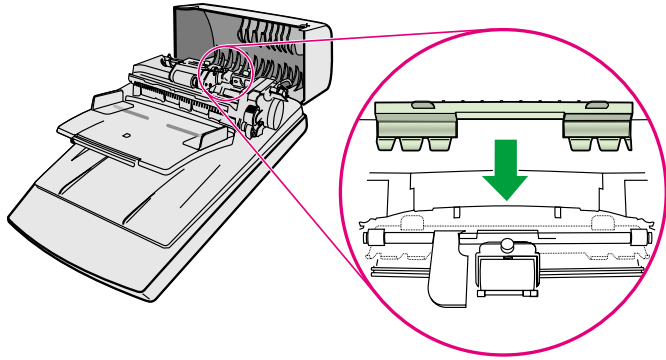

- 5 Close the hatch. Press down firmly until you hear a click.

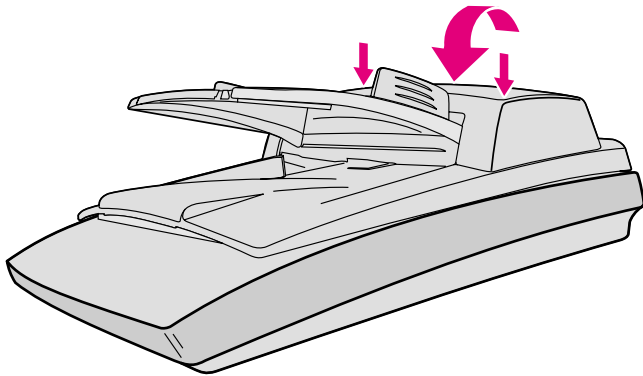

- 6 Restack all pages and reload them into the ADF.

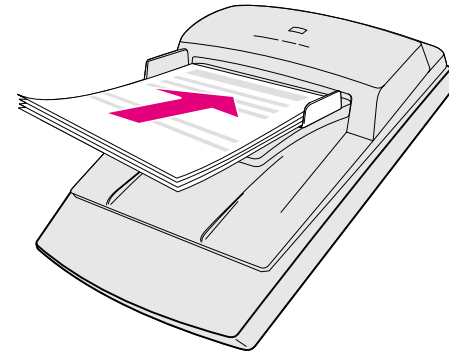

- 7 On the ADF prompt on the computer, reselect any settings you had changed and click **Scan To** or **Scan** again.

*To clear jams at the end of a page*

- 1 Remove any pages from the ADF input tray.
- 2 Remove the input tray from the ADF.

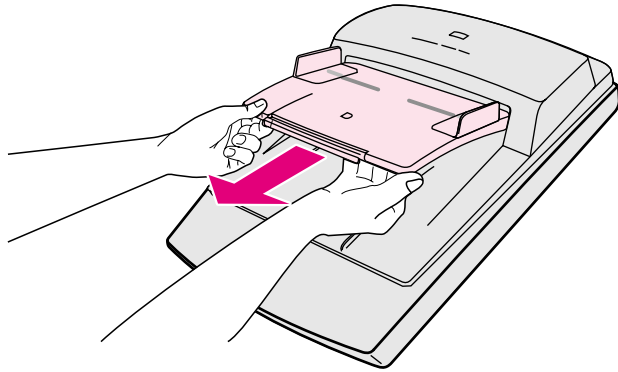

- 3 Gently pull the paper out of the ADF in the feeding direction (towards you).

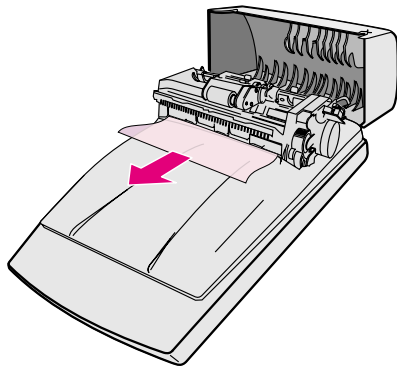

- 4 If you still cannot remove the paper from the ADF, lift the ADF lid to its fully open position, loosen the jammed paper from the roller at the rear of the ADF lid, pull it gently from the ADF.

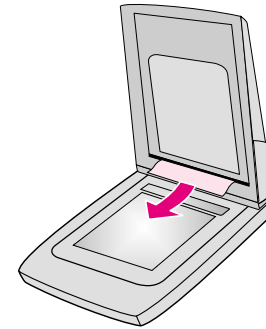

- 5 When you have successfully cleared the jam, attach the input tray and close the hatch. Press down firmly on both sides until you hear a click.
- 6 Restack all pages and reload them into the ADF.
- 7 On the ADF prompt on the computer, reselect any settings you had changed and click **Scan To** or **Scan** again.



## Cleaning and maintaining

Periodically, the scanner and accessories might need to be cleaned or to have maintenance, especially if you are seeing marks or smudges on scanned images.

### Cleaning the scanner glass

You might need to clean the scanner glass if the ink on items you are scanning can be smudged with your hand or items have excessive amounts of dust or dirt on them. You might also need to clean the scanner glass if there are smudges or other marks on scanned images.

*To clean the scanner glass*

- 1 Disconnect the power cable from the scanner.
- 2 Open the scanner lid.
- 3 Clean the glass using a soft, lint-free cloth sprayed with a mild glass cleaner.

**CAUTION** Only use glass cleaner. Avoid abrasives, acetone, benzene, and carbon tetrachloride, all of which can damage the scanner glass. Avoid isopropyl alcohol because it can leave streaks on the glass.

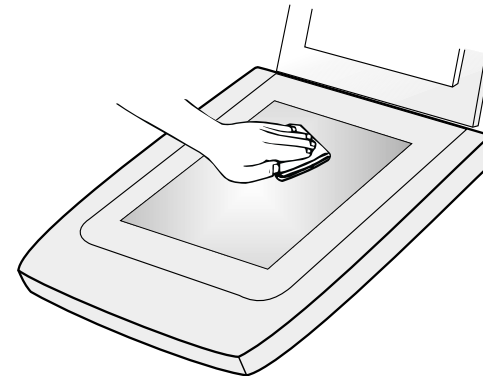

- 4 Dry the scanner glass with a dry, soft, lint-free cloth.
- 5 When finished, reconnect the power cable to the scanner.

Fingerprints or smudges on the underside of the glass do not affect the appearance of scanned images because this area of the glass is outside the focal point of the scanner.

## Cleaning the XPA

(Some models only, see "[Front panel and accessories comparisons](#)" on page 3.) Clean the XPA with a dry, soft cloth. If necessary, spray the cloth with window cleaner or isopropyl alcohol.

## Cleaning the ADF glass

(Some models only, see "[Front panel and accessories comparisons](#)" on page 3.) You must clean the ADF glass to maintain high-quality scanning.

### *To clean the ADF glass*

- 1 Disconnect the power cable from the scanner.
- 2 Open the scanner lid and locate the ADF glass area on the scanner glass.

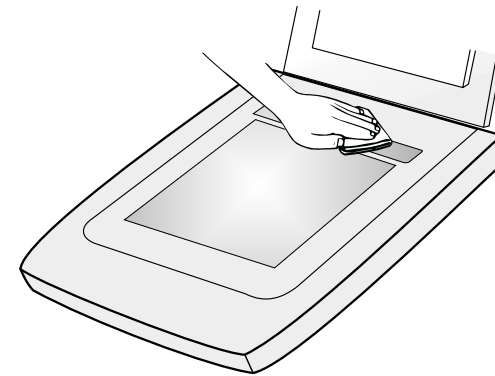

- 3 Clean the glass using a soft, lint-free cloth sprayed with a mild glass cleaner.

**CAUTION** Only use glass cleaner. Avoid abrasives, acetone, benzene, and carbon tetrachloride, all of which can damage the scanner glass. Avoid isopropyl alcohol because it can leave streaks on the glass.

- 4 Dry the scanner glass with a dry, soft, lint-free cloth.
- 5 When finished, reconnect the power cable to the scanner.

Fingerprints or smudges on the underside of the glass do not affect the appearance of scanned images because this area of the glass is outside the focal point of the scanner.

## Uninstalling the software

The Uninstall option of the setup program allows you to remove the scanning software from your computer.

See the [Setup and Support Guide](#) for installation and troubleshooting information.

## Other resources, support, and specifications

The [Setup and Support Guide](#) contains information about these topics:

- **Setup instructions and troubleshooting.** Find setup instructions and troubleshooting information for issues that can arise when you install the scanner.
- **Resources.** Discover websites and other tools that contain scanning tips, updated drivers, and the latest information about your HP scanner.
- **Support.** Locate the contact information for your region if you need to contact HP.
- **Warranty and Specifications.** See this topic for the warranty and product and regulatory information.

See the **Read Me file** for late-breaking information about the HP PrecisionScan Pro software. This file is located in the same folder as the Setup and Support Guide.

The Setup and Support Guide and the Read Me file are located on the CD in the folder for your language, or on your computer in the PrecisionScan Pro folder. If you allowed the software to install in the default location, the path is: C:\Program Files\Hewlett-Packard\PrecisionScan Pro 3.1.



# A Using software commands and controls

This section contains information for using the shortcuts, toolbars, and cursors in the HP Precisionscan Pro software.

The HP Precisionscan Pro contains keyboard shortcuts and toolbars to give you quick access to software commands. The Status bar and Info bar provide information about the scanned image, and the context-sensitive cursors provide information on the type of activity you can perform in the scanning software.

## Using keyboard shortcuts and the menus

This section summarizes the menus and commands in the HP Precisionscan Pro software that you can select using the keyboard. To open a menu, press **ALT+** the underlined letter for that menu. To perform a command, open the menu and press the underlined letter for that command.

This section also shows which commands can be performed using a keyboard accelerator (shortcut).

### Scan

<u>N</u> ew Scan	<b>CTRL+N</b>	Start (preview) a new scan.
Scan <u>I</u> o...	<b>CTRL+T</b>	Scan and send to a destination, such as e-mail.
Scan to <u>C</u> D		Save scanned photos or documents on a CD-writer drive.
<u>R</u> eturn Image to...		When using TWAIN, return the scanned image to the other program.
<u>S</u> ave As...	<b>CTRL+S</b>	Save the selection area as a file.
<u>P</u> rint	<b>CTRL+P</b>	Scan and print the selection area.
Print <u>S</u> etup		Change printing options.
Scanner <u>G</u> lass XPA (S <u>l</u> ides) XPA (N <u>e</u> gatives)		Select the source from which to scan. Only one can be selected.
<u>S</u> ettings		
<u>S</u> ave		Save settings.
<u>L</u> oad		Load (use) settings.
<u>P</u> references		Change scanning default preferences.
<u>E</u> xit	<b>ALT+F4</b>	Close the HP Precisionscan Pro software.

### Edit

<u>R</u> eset Tools	<b>CTRL+Z</b>	Return all settings except output type to the defaults for this image.
<u>C</u> opy	<b>CTRL+C</b>	Scan and place the selection area on the Clipboard.
Select <u>A</u> ll	<b>CTRL+A</b>	Select the entire scanner glass (including blank space).
<u>U</u> nselect All	<b>ESC</b>	Remove the selection border.

### View

<u>Z</u> oom In	Zoom in on the selection area.
Zoom <u>O</u> t	Zoom out to the original view.
<u>G</u> uided Steps	Show or hide the Guided Steps.
<u>T</u> ool Bar	Show or hide the toolbar.
<u>I</u> nfо Bar	Show or hide the Info bar.
<u>S</u> tatus Bar	Show or hide the Status bar.

**Note:** The Guided Steps are available for computers running Internet Explorer version 4.0 or greater. See "[Resolving issues that did not generate messages](#)" on page 87.

### Output Type

True Color (16.7 million colors)

256-Color (optimized palette)

256-Color (web palette)

Spot Color (16-color)

Grayscale

Black & White Bitmap

Black & White Scalable

Editable Text (OCR)

Text and Image

Automatically Set Type

Choose the output type. Only one can be selected. For help choosing an output type, show the Guided Steps from the **View** menu.

Allow the software to select the output type based on the contents of selection area.

### Tools

Rotate Left 90°

Rotate the image counterclockwise by 90 degrees.

Rotate Right 90°

Rotate the image clockwise by 90 degrees.

Mirror

Reverse the image side-to-side.

Resize

Resize the selection area. This changes the output file size also.

Change Resolution

Change the resolution of the final scanned image.

Sharpen

Adjust the sharpening.

### Advanced

Adjust Color

Adjust colors (hue) and their intensity (saturation).

Adjust Exposure

Adjust the contrast (midtones), detail in light areas (highlights), and detail in dark areas (shadows).

Adjust Black & White

Adjust which values in the image will be represented as black or white.

Invert Colors

Make colors in the image their opposites.

Descreen

In the scanned image, reduce the appearance of undesirable patterns that are in a printed original.

**Help**

<u>C</u> ontents	<b>F1</b>	View Help topics (contents).
<u>S</u> earch		Look for a Help topic.
<u>W</u> hat's This?	<b>SHIFT+F1</b>	Display context-sensitive Help for the selected software tool or feature.
<u>H</u> P Scanjet on the Web		Connect to the Internet and visit the HP Scanjet website.
<u>P</u> roduct Tour		View the product tour.
<u>U</u> ser's Manual		View the printable user's manual in .pdf format.
<u>E</u> nable All Smart Friends		Allow helpful alerts to appear when potential problems arise.
<u>D</u> isable All Smart Friends		Prevent helpful alerts from appearing when potential problems arise.
<u>A</u> bout HP Precisionscan Pro		View information about the program, version, and copyright.

**Note:** Help is available for computers running Internet Explorer version 4.0 or greater. See ["Resolving issues that did not generate messages"](#) on page 87.

















## HP Precisionscan Pro tool and information bars

The HP Precisionscan Pro software contains a toolbar, a Status bar, and an Info bar to help you use commands quickly or find information about the current scanned image.

### Toolbar

The HP Precisionscan Pro software displays a toolbar containing shortcut buttons for common commands.

Click this button	To
 New Scan	Start (preview) a new scan.
 Scan To...	Perform a final scan and send to a destination, such as e-mail.
 Scan to CD	Scan and save the selection to rewritable CD.
 Save As...	Save the selection area as a file.
 Print	Scan and print the selection area.
 Return Image To	When using TWAIN, return the scanned image to the other program.
 Copy	Scan and place the selection area on the Clipboard.
 Zoom In	Zoom in on the selection area.

 Zoom Out	Zoom out to the original view.
 Rotate Left 90	Rotate the image counterclockwise by 90 degrees.
 Rotate Right 90	Rotate the image clockwise by 90 degrees.
 Reset Tools	Return all settings except output type to the defaults for this image.
 Guided Steps	Show or hide the Guided Steps.
 Context Help	Display context-sensitive Help for the selected software tool or feature.

**Note:** The Guided Steps are available for computers running Internet Explorer version 4.0 or greater. See "[Resolving issues that did not generate messages](#)" on page 87.

## Adding tools to the toolbar

You can add the Change Resolution tool and the Sharpen tool to the toolbar.

*To add Change Resolution and Sharpen tools to the toolbar*

- 1 On the **Tools** menu, click **Change Resolution** or **Sharpen**.
- 2 When the dialog box opens, place the cursor over the title of the dialog box, and click and hold down the mouse button.
- 3 Drag the cursor to a location on the toolbar and release the mouse button.

## Info bar

The info bar appears at the bottom of the preview window and displays the following information:

- the width of the output image
- the height of the output image
- scale of the output image
- the output type currently selected
- the Help button for HP Precisionscan Pro software

## Status bar







The status bar displays the following information:

- A message about the action you can take when the pointer is over some part of the scanning software window or a tool.
- An icon for the transparency adapter when it is in use.
- One of the following:
  - A progress bar that shows when the scanner is scanning or the scanning software is processing a command.
  - The number of KB (kilobytes), MB (megabytes), GB (gigabytes), or TB (terabytes) in the image in the selection area. This size is only an estimate of the actual size of the image. The file can be larger or smaller than the value shown here. The size of a saved file depends on the format used to save the file.

## Context-sensitive cursors

The shape of the pointer indicates the type of activity you can perform in the scanning software.

### Selection area cursor

New selection area		Draw a new selection area.
Move selection area		Drag the selection area to a new location in the preview area. Drag the selection area to another program. Press <b>CTRL</b> and drag the selection area to the Windows desktop or a folder in Windows Explorer.
Resize selection area horizontally		Appears over handles on the sides of the selection area. Drag the cursor to resize the width of the selection area.
Resize selection area vertically		Appears over the handles on the top or bottom of the selection area. Drag the cursor to resize the height of the selection area.
Resize selection area diagonally		Appears over handles on the corners of the selection area. Drag the cursor to resize both the height and width of the selection area.
Drop allowed		The program or folder the image has been dragged to accepts this kind of drop.
Drop not allowed		The program into which you are trying to drag the image does not accept this kind of drop.



### Ready cursor

Ready for activity		Click a menu item and select a command. Click a list button to select an option. Click a button to turn it on or off, or to increase or decrease a number.
--------------------	---	--

### Typing cursor

Data entry accepted		Click, then type a value.
---------------------	---	---------------------------

### Pixel value cursor

Highlight eyedropper		Position this cursor over a light area in the image to see its pixel value in the RGB meter and the histogram. Click on pixels to set them as the Highlight value. In the Transparency Exposure Adjustment tool, click to set the RGB value.
Shadow eyedropper		Position this cursor over a dark area of the image to see its pixel value in the RGB meter and the histogram. Click on pixels to set them as the Shadow value.
Eyedropper and the "no" symbol		Indicates this area is an area in which pixel value is not available.

### What's This? Help cursor

What's This? Help		Click on a tool, field, button, or menu item for pop-up Help on that item.
-------------------	---	--

# B Glossary

a b c d e f g h i j k l m n o p q r s t u v w x y z

## *8-bit grayscale*

Used to represent black-and-white photos accurately. These grayscale images contain 256 shades of gray.

## *24-bit color*

Color images composed of three 8-bit color channels. When combined, the red, green, and blue channels provide up to 16 million colors. This is also referred to as *true color*.

## *256 Color (optimized palette)*

The palette for an image which comprises the 240 most common colors in the image plus the 16 basic colors.

## *256 Color (web palette)*

A palette or color table containing red, green, and blue pixel colors that are standard for images embedded in Web pages or .html files.

## *.bmp*

The filename extension used for Windows bitmap images. *See also Windows bitmap.*

## *.dib*

Device Independent Bitmap. A common bitmap format for Windows programs.

## *.fpx*

The filename extension used for FlashPix files.

## *.gif*

The filename extension for Graphics Interchange Format files.

## *.htm*

The filename extension for HyperText Markup (HTML) files. This extension also appears as .html.

## *.jpg*

The filename extension for JPEG files.

*.pcx*

The filename extension for Paintbrush files.

*.pdf*

The filename extension for Portable Document Format (PDF) files.

*.png*

The filename extension for Portable Network Graphics (PNG) files.

*.rtf*

The filename extension for Rich Text Format files.

*.tif*

The filename extension for TIFF or TIFF compressed files.

*.txt*

The filename extension for plain text files.

*.wmf*

The filename extension for Windows metafiles.

## a

*acquire*

A command offered by programs that support TWAIN. Selecting Acquire takes you directly to a selected scanning software, and then returns the scanned image to the requesting program.

*active program*

The program you are currently using or that is currently selected. A program's title bar changes color to distinguish active from inactive programs.

*Active XPA*

Or XPA. See *transparency adapter*.

*ADF*

See *automatic document feeder*.

*ADF glass*

The piece of glass on the scanner bed that the ADF uses to scan documents from the feeder tray.

*aliasing*

The visibly jagged steps along angled lines or object edges that result from sharp tonal contrasts between pixels. Seen in both black-and-white images and color images. Sometimes called Jaggies.

*anti-aliasing*

A technique that smooths transitions between pixels, reducing the jaggedness of curved lines.

*approximate size*

Reflects the amount of disk space a scan would require if saved to your computer. Approximate Size value does not apply if the output type for the scan is set to text; it only applies to an image representation of the scan.

### *auto(matic) cropping*

Automatic cropping displays only the item(s) detected on the scanner bed, not any of the surrounding area.

### *automatic document feeder*

Abbreviated ADF, it is an optional accessory that allows you to scan multiple pages.

### *auto(matic) resolution*

A feature of the scanning software that automatically applies the optimal output resolution to the selection area. For example, output resolution is automatically set to 200 when the True Color output type is selected, and set to 300 for the Black & White Bitmap (raster) output type.

## **b**

### *bit depth*

The number of bits used to define the shade or color of each pixel in an image. A 1-bit image is black and white. An 8-bit grayscale image provides 256 shades of gray. An 8-bit color image provides 256 indexed colors and is associated with a specific palette or color table. A 24-bit image provides over 16 million colors. The greater the bit depth, the larger the size of the saved file. *See also file size.*

### *bitmap*

A type of black-and-white, gray, or color image or picture made up of a matrix of individual pixels or dots. Often referred to as raster, raster bitmap, or raster image.

### *black & white bitmap*

Black & white raster bitmaps contain only black pixels and white pixels, no colors or shades of gray. Each pixel represents one bit.

### *black & white scalable*

Black & white scalable images are black & white images made up of lines rather than dots. These images must be saved as .wmf files.

### *Black & White (threshold) tool*

This tool lets you change the dividing point for black-and-white pixels in an image that uses the Black & White Bitmap (raster) output type. All pixels below the threshold will be output as black, and all pixels above the threshold will be output as white.

### *border*

A line surrounding the scanned image indicating scanning boundaries. Clicking the image reveals a selection border and handles that are used to define the scanning region.

### *brightness*

The balance of light (highlights) and dark (shadows) in an image. In black-and-white images, the lower the brightness, the closer the image will be to black. The higher the brightness, the closer the image will be to white. Brightness should not be confused with contrast, which measures the range between the darkest and lightest shades in an image. Brightness determines the intensity of shades in an image, while contrast determines the number of shades in the image.

## C

*click*

To press and release the *left* mouse button once. *Right-click* means to press and release the *right* mouse button once.

*clipped pixels*

Pixels in an image that are extremely light or extremely dark and that would lose detail when the image is printed or displayed.

## CMYK

Cyan, Magenta, Yellow, Black. The color model in which all colors are composed of Cyan, Magenta, and Yellow, the primary colors of pigments like ink, plus Black. Printers use CMYK to print in color.

*converted text*

Text that has been rendered into digital format by an OCR program.

*color balance*

The preservation of balance between colors throughout the tonal range. Color balance is particularly important when scanning objects that include neutral tones (grays) or large areas of consistent color.

*color channel*

The red, green, and blue components from which colors are created.

*color correction*

The process of adjusting an image to compensate for input and output device characteristics or color flaws in the original image.

*color depth*

The number of colors that a monitor can display at once. Most PC monitors display 8-bit color (256 colors), 16-bit color (about 65,000 colors), 24-bit color (about 16 million colors), and 32-bit color. The higher the color depth, the more lifelike images look on screen.

*color wheel*

A tool used to adjust the color balance and hue.

*configure*

The ability to adjust settings that determine how the scanner buttons and scanning software perform operations.

*context-sensitive Help*

Context-sensitive Help answers questions related to specific features in the currently displayed window. The Help is provided in six ways: Text Labels, ToolTips, What's This? Help, Smart Friends, Status bar messages, and Help commands.

*contrast*

The range between the lightest and darkest shades in an image. An image with high contrast has few gray shades between black and white and appears to be dominated by stark light and dark tones. An image with low contrast has many shades of gray and tends to look flat and dull. Change contrast using the highlight, shadow, and midtone settings.

*control range*

This range determines the number of bits used for exposure compensation, shadow detail, and black-and-white threshold adjustment displays. The higher the bit depth, the finer the level of control in adjusting these image manipulation functions.



*crop*

To eliminate portions of an image from the final scan.

**d**

*default settings*

Predetermined settings in the scanning software that define levels on the your behalf. Default settings in the HP Precisionscan Pro software are set for Output Type, Output Resolution, Color, Exposure, Black & White Threshold, and Sharpen Level. You can override default settings.

*density*

The ability of a material to absorb or transmit light. The greater the density of a material or object, the more black it contains. This applies to both black-and-white images and color images.

*descreen*

The process of removing an unwanted pattern, such as a moiré pattern, that appears in a printed original so the pattern does not appear in the scanned image.

*destination*

The file, program, or hardware device where the scanned image will be used. Examples include a printer, a Web page, or an e-mail program.

*device driver*

Software that the system uses to communicate with devices, such as a display, printer, mouse, or scanner.

*display resolution*

The number of pixels that a computer monitor can display both horizontally and vertically. Screen resolutions are typically 640 x 480 (VGA), 800 x 600 (super VGA), or 1024 x 786.

*dithering*

The process of approximating pixel colors when reducing the color depth of an image. Dithering can improve transitions between colors when reducing a 24-bit image to 8-bit format.

*dock*

To attach a tool window to the main program window.

*document*

For the purposes of this documentation, document refers to an original item containing text or both text and images. It also means an original item scanned using the automatic document feeder.

*dots per inch*

See *dpi*.

*double-click*

To press and click a mouse button twice in rapid succession.

*dpi*

Dots Per Inch. The number of dots in a linear inch. DPI measurements are used to describe the resolution of printers and scanners, where printed images and words are made up of a series of round dots. The greater the DPI number, the higher the resolution.

*drag*

To move an object on screen. Place the cursor over the image or selection area, hold the left mouse button down, and move the mouse to move the object.

*drag-and-drop*

To move an object to a new location and keep it there. Click on the object and drag it to a new location, such as an open document in another program, and release the mouse button. When dragging-and-dropping between programs, a copy of the object is placed in the receiving program.

*drop-down list (or menu)*

A list of items that appears when you click on or pass the cursor over a command such as **File** or **Edit**.

## e

*editable text*

Text that is converted from a scanned image into characters you can modify in a word processor or other text-editing program. Depending on the capabilities of your program, you can change the font, size, style, and other attributes of editable text, as well as edit words or phrases.

*e-mail*

A network over which you can transfer messages and electronic files. E-mail is also sent via Internet browsers.

*export*

To save a file in a particular file format for use in other programs.

*exposure*

The amount of light, or brightness and contrast, in an image.

## f

*file format*

The format in which a scan is saved. Certain file formats enable programs such as word processors to insert, open, or import scans. Common graphics formats include .bmp, .jpg, and .tif. Common text formats include .txt (text) and .rtf (Rich Text Format).

*file size*

The number of bytes in a file. The file size of scanned images is determined by resolution, file type, output type, and scaling. To reduce the file size of photographs, for example, you could decrease bit depth or resolution.

*final scan*

The actual image, defined by the selection area, that is sent to a destination such as a file, a printer, the Clipboard, or another program.

*final size*

The approximate height and width of the final image to be scanned.

*FlashPix*

A format that allows faster processing, but creates larger file sizes. FlashPix files, which save with the .fpx extension, can be used on Windows and Macintosh platforms. The format was developed by Hewlett-Packard, Kodak, Live Picture, and Microsoft.

### *flowed text*

The Flowed Text option converts output into one column, placing images as closely as possible to the appropriate text.

### *framed text*

The Framed Text option places text and images in a frame, positioned as closely as possible to the way they appear in the original document. Text may be more difficult to edit extensively since the frames may not expand to hold additional text.

### *focus*

Refers to the sharpness of an image.

### *front panel*

The area on the front of the scanner hardware containing the buttons for sending an item to a destination or changing settings.

## g

### *gamma*

The contrast that affects the mid-level grays or midtones of an image. Adjusting the gamma of an image allows you to change the brightness values of the middle range of gray tones without dramatically altering the shadows and highlights. This applies to both black-and-white images and color images. The default setting of 2.2 ensures integrity among computer systems.

### *grainy*

Refers to images, pictures, or photographs in which individual pixels are relatively large and have areas of white between them, thus reducing the overall perceived quality of the image. Graininess can occur when you scan a poor-quality original or reduce the bit depth of the scanned image by dithering or halftoning.

### *Graphics Interchange Format*

A graphic file format that is supported by many Windows programs. Files saved in this format support 256 colors. Graphics Interchange Format files are saved with the filename extension .gif.

### *grayscale*

An original or output type containing shades of gray, not just black and white. In a grayscale image, each pixel contains multiple bits of information, allowing more shades of gray to be recorded and displayed. Four bits can reproduce up to 16 levels of gray, and eight bits can reproduce 256 shades of gray. Grayscale is commonly used for black-and-white original photographs but is also effective in maintaining shading in pencil drawings.

## h

### *halftone*

An original composed of a pattern of dots that tricks the eye into seeing shades of gray or color. Halftones are common in all printed materials. Scanning halftones instead of photographic originals can result in lower final image quality.

### *height*

The vertical dimension of a scan as it will appear at its destination.

### *highlights*

The lightest portion of an image, usually reproduced as white on the computer screen or when printed.

### *histogram*

A graphical representation of the concentration of pixels at each intensity or gray level in the selection area of the scanned image. Histograms help determine the optimal highlight, shadow, or threshold value of an image.

### *HP Scanjet Copy Utility*

A software utility used to select number of copies, destination printer, and other copy options.

### *HP Precisionscan Pro software*

The scanning software that HP provides for previewing an image before sending it to a destination; making changes, such as resolution, resizing, and contrast; and saving images as files.

### *HP Share-to-Web*

An automated feature that sends scanned images directly to a destination on the Web. Links are available only in English.

### *HTML*

HyperText Markup Language. A language used in creating documents for the World Wide Web. Documents can be saved in HTML format and will have an .htm or .html extension.

### *hue*

The distinctive characteristic of a visible color that enables you to distinguish it from other colors. Six hues are especially important in photography, scanning, and printing: red, yellow, green, cyan, blue, and magenta. Hue is determined by the frequency of the wave of light that creates the color. *See also saturation.*

### *i*

### *image*

An electronic picture that can be displayed on a computer screen or saved to a disk.

### *image editor*

A program that lets you modify bitmapped drawings and photographs.

### *image size*

The size of the image expressed in bytes and displayed in the Status bar. File size and image size may vary, depending on the file type.

### *import*

To bring a scanned image into a document from another program.

### *Info bar*

A form of assistance that appears in the lower, left corner of the screen and displays the width and height of the output image, the scale percentage, the output type currently selected, and a **Help** button.

### *interface connection*

The connection between the scanner and the computer. This can be either a USB, parallel, or SCSI connection depending on the model of scanner and your operating system.

### *interpolated resolution*

Resolution that is changed in the scanning software rather than in the hardware. For example, if your scanned image is 600 dpi, you might be able to enhance it to 1200 dpi in the scanning software. This is useful for enlarging small images.

### *interpolation*

The process of increasing the resolution of an image by the addition of new pixels throughout the image, the colors of which are based on neighboring pixels.

### *invert*

To reverse the colors in an image (for example, in a black-and-white image, black areas are turned white and white areas are turned black).

### *item*

The physical drawing, photo, collage, etc. you place in the scanner to scan. Once it is scanned, it is referred to as an image or scanned image.

## i

### *jagged*

Refers to the uneven transition between black and white, or areas of color, in a scanned image. Jagged edges can be avoided by scanning at a higher resolution than your output device, or by not scaling the image after scanning it.

### *JPEG*

Joint Photographic Experts Group. A compressed file format that reduces file size and enables faster file access. This format can reduce image quality and performance when the file is decompressed and recompressed. JPEG files are saved with the filename extension .jpg.

## k

### *keyboard shortcuts*

A keystroke or combination of keystrokes that allows you to quickly accomplish common tasks.

## l

### *landscape*

The orientation of a photograph or image that is wider than it is tall. When an image is taller than it is wide, it is called portrait orientation.

## m

*maximum pixel depth*

This option enables higher bits per pixel when the scan is sent to the software. When it is off, 8 bits per pixel are returned for grayscale and 24 bits for color. When it is turned on, 16 bits per pixel are returned for grayscale and 48 bits for color.

*midtones*

The gray shades of an image. Midtones are usually between 30% and 70% black. Midtone control adjusts the brightness of gray levels in the image so that the lightest and darkest portions of the image can be properly displayed on your monitor. The higher the setting, the brighter the image appears on your monitor.

*moiré*

An undesirable pattern in color printing that results from incorrect screen angles of overprinting halftones. Moiré patterns usually result when you scan a halftone, when you scan images taken directly from a magazine, or when you scale an image in an image editor after it is scanned.

## n

*negative holder*

This XPA piece holds negative strips for scanning. Insert it into the slide holder on the bottom of the XPA light source for proper scanning of negatives.

*negative light shield*

This XPA piece blocks excess illumination and improves image quality when scanning negatives. Slide it into the negative holder after the chosen negative strip.

*negative template*

The cutout that comes with the optional transparency adapter that is placed on the scanning glass. Negatives are then placed in the template.

*noise reduction*

This option reduces the noise (unwanted specks) in an image by applying software algorithms to minimize the effects of noise in the scanner electronics.

## o

## OCR

*See optical character recognition.*

*optical character recognition*

Abbreviated OCR. A technology that recognizes letters in a scanned image and converts them into ASCII characters, or editable text.

*optical resolution*

The true resolution of a scanner, the resolution at which the scanner captures images. *See also: interpolated resolution, resolution.*

*optimized palette*

A palette or color table that contains the pixel colors present in an image.

*original*

The original document or picture to be scanned.

*output*

The file that is generated by the scanning process.

*output dimensions*

The actual height and width of an image when saved. You will not see the size changes to your image in the Preview area since image size affects only the final scan.

*output type*

The type of file that is generated during the scanning process. Output type reveals the bit depth of the image.

**P***Paintbrush*

A bitmap file format (.pcx extension) supported by MS-DOS, Windows, UNIX, and other platforms, and numerous programs. Paintbrush files support 24-bit color and can have a maximum image size of 64,000 by 64,000 pixels.

*palette*

A subset of the color look-up table that establishes the colors that can be displayed on the monitor at a particular time. The only color depth that allows multiple palettes is the 256 (or 8-bit) color setting for your monitor. At a color depth of 256 colors, each program (or even each individual image used or edited in a program) can have a different color palette.

*palette flashing*

The flashing that occurs when your monitor is set to a color depth of 256 colors and you switch programs. When you switch programs, the palette of the active program becomes the system palette, and all other programs redraw themselves as accurately as possible with the new colors.

*PC fax program*

A program for sending electronic documents to someone's fax machine or PC fax program. Also allows receiving of faxed documents to the computer instead of a fax machine.

*pixel*

The smallest element (picture element) that can be assigned an independent color and intensity and can be displayed on a computer screen. Pixels are square dots arranged in a grid pattern to make up the images displayed on the screen.

*PNG*

Portable Network Graphics format. A compressed image file format suitable for the Web that might replace GIF because of copyright issues with GIF format. PNG is non-lossy compressed, supports interlacing, and can be used with the True Color output type, which GIF cannot.

*portrait*

Orientation of a photograph or image that is taller than it is wide. An image that is wider than it is tall is called a landscape orientation.

*positioning plate*

This XPA piece is a large template with a rectangular cutout that orients proper placement of the XPA light source on the scanner bed.

### *posting scans*

Term for scanning items directly to a website.

### *Power Save*

An energy conservation method that reduces power consumption when the scanner is idle for a period of time.

### *PPI*

Pixels Per Inch. A measurement of resolution for monitors and scanners where the individual element is a square pixel.

### *preferences*

Refers to your preferred method of using the scanner. The scanning software automatically saves certain preferences, such as the location of toolbars and the destination of a scan, that it detects during normal use of the scanner. Some preferences are restored each time the scanner is used, while others are maintained only throughout a scanning session.

### *preview*

A feature that displays a scanned image so you can view it in the scanning software. You can then select an area to be saved; make adjustments to the tone, color, and size; and save the final image.

### *preview window*

The rectangular area in the software where the scanned image is displayed.

### *printer resolution*

A measurement of the number of dots per inch (dpi) the printer is capable of printing. Typical laser printers have resolutions of 600 dpi, typical ink printers have resolutions of 300 dpi for photographs and 600 dpi for text, while imagesetters have resolutions of 1200 or 2400 dpi. The more dots per inch, the smoother the output and the greater the number of grayscale levels and colors the device can describe.

### *product tour*

The product tour provides an overview of the scanner's capabilities and how scanning tasks are completed. It appears each time the scanning software starts, unless it is specifically disabled. It is also available in the **Help** menu.

## q

## r

### *raster*

A type of black and white, gray, or color image or picture made up of a matrix of individual pixels or dots. This is also referred to as a bitmap.

### *resolution*

The measure of how many dots per inch (dpi) are scanned, displayed, or printed. The greater the dpi, the greater the amount of detail that is visible, and the larger the file size. The final output device (monitor, printer) for a scanned image determines the resolution of the image. For example, if you scan a picture at 600 dpi (the optimum) and your printer is capable of printing at only 300 dpi, the printed image will be no more than 300 dpi.



## *RGB*

Red, Green, Blue. The color model in which every color is composed of a varying amount of red, green, and blue, which are the three primary colors of light. RGB is used to display colors on a computer monitor.

## *rich text format*

A format for text files. Rich Text Format preserves all formatting in the original text document. It converts formatting into instructions that compatible programs can interpret. Rich Text Format files are saved with the filename extension .rtf.

## *right-click*

To press and release the right mouse button once.

## *rotate tool*

To rotate the entire scan 90 degrees clockwise or 90 degrees counterclockwise.

## **S**

## *saturation*

The intensity of color in a specific hue. An image with high color saturation has vivid color. A black-and-white photograph has zero saturation. *See also hue.*

## *scale*

To reduce or increase the physical size of an image while maintaining aspect ratio (the ratio of the horizontal dimension to the vertical dimension).

## *scan*

To capture a picture, photograph, or text as a digital electronic image using a scanner. This term also refers to the image that has been scanned.

## *scanner bed*

The glass surface of the scanner where you place items to scan. Sometimes referred to as the scanner glass.

## *scanner glass*

The glass surface on the scanner where you place items to scan. Sometimes referred to as the scanner bed.

## *scanner lid*

The lid, or cover, of the scanner, which holds the original paper flat for scanning.

## *scanning source*

Scanning (or scan) sources include the flatbed, transparency-slides, and transparency-negatives.

## *screen resolution*

The measurement of the number of lines per inch (lpi) that a screen can display. This is usually 75 lpi.

## *selection area*

The area inside the rectangular border drawn around a portion of the image in the Preview area. The selection area is scanned when you drag-and-drop, save to a file, copy to the clipboard, or print.

### *settings*

Saving settings allows you to save a set of settings used with one scanned image and reuse the settings with an image scanned in the future.

### *shadow*

The darkest area of an image, usually reproduced as near black on the computer screen or when printed. The range between highlight and shadow determines the quality and color differentiation in the image.

### *sharpen*

To enhance the detail in an image.

### *slide holder*

This XPA piece holds slides for scanning. It is attached to the bottom of the XPA light source.

### *slide light shield*

This XPA piece blocks excess illumination and improves image quality when scanning slides. Slide it into the slide holder after the chosen slide(s).

### *Smart Friends*

Smart Friends are tips that appear automatically to notify you of potential problems. For example, if you are setting a very high resolution but want to use e-mail to send the scanned image, a Smart Friend would alert you that the file will probably be too large to send in e-mail.

### *source*

The program from which an image is retrieved for use in a document. TWAIN-compliant programs pull an image from a source, such as the HP Precisionscan Pro software.

### *spot color*

A software function that finds large areas of color in a scanned image and applies a uniform color to the area.

### *Start button*

The button in the (Windows) Taskbar that can be used to start a program quickly, find files, change settings, and open documents.

### *status bar*

The area at the bottom of most Windows program screens that shows information about the current action in progress.

### *system palette*

A palette or color table containing a Web palette plus more shades of gray and the 16 VGA colors.

### †

### *Taskbar*

A toolbar that docks to the edge of the Windows Desktop. The Taskbar includes the **Start** button, buttons for each open program, and a status area.

### *text*

As it relates to scanning, text is saved in the following formats: .txt, searchable .pdf, .htm, and .rtf.

### *thresholding*

The process of rendering all areas darker than a set value as black, and all areas lighter than a set value as white. Useful when converting grayscale images to black and white.

### *TIFF*

Tagged Image File Format. A bitmapped file format for images, capable of storing up to 24-bit depth images. TIFF file format is especially appropriate for scanned images and is supported by many programs and computers. TIFF files are saved with the filename extension .tif.

### *TIFF compressed*

Tagged Image File Format, compressed. A bitmapped file format for images, capable of storing up to 24-bit depth images. TIFF file format is recommended for scanned images and is supported by many programs and computers. TIFF compressed files use data compression to reduce the size of the resulting file. TIFF compressed files are saved with the filename extension .tif.

### *tone*

The overall effect produced by the combination of lighting, shade, and color.

### *toolbar*

The area that contains buttons for a program's controls.

### *ToolTip*

A brief description that appears when the mouse pointer pauses over a control (such as a menu item or toolbar button) in a software program's window.

### *transparency adapter*

Abbreviated as XPA. An optional accessory used to scan negatives and slides. An XPA connector is plugged into the scanner, and a template is used to position the transparency above the glass.

### *True Color*

An image type that is rendered with 24-bits per pixel per color.

### *TWAIN*

An industry-standard communications protocol for sending instructions to hardware (such as a scanner) and receiving image data back from them. If you are using a program that supports TWAIN, you can start the HP Precisionscan Pro software directly from that program.

## U

### *uniform scaling*

A method of stretching or shrinking an image proportionately in both the vertical and horizontal directions.

### *USB*

Universal Serial Bus. An interface for connecting peripherals, such as scanners, to a computer.

## V

### *vector*

A type of image that uses algebraic equations to define the various lines and curves of the image.

## W

*Web palette*

A palette or color table containing red, green, and blue pixel colors that is standard for images embedded in Web pages or .htm files. It consists of 216 entries of all combinations of the values 0, 51, 102, 153, 204, and 255.

## WIA

Windows Imaging Application. The method Word uses to bring scanned images into an open Word document. Similar to TWAIN.

*width*

The horizontal dimension of your scan as it is sent to its destination.

*Windows bitmap*

A bitmapped file format for pictures, supported by most Windows programs. Windows bitmap files support 1-, 4-, 16-, 24-, and 32-bit color. Windows bitmap files are saved with the filename extension .bmp.

*Windows metafile*

A file format supporting 24-bit color used to store and exchange image data between Windows-based programs. Windows metafiles are saved with the filename extension .wmf.

## X

## XPA

*See transparency adapter.*

*XPA light source*

This XPA piece is a light that plugs into the scanner. It fits into the positioning plate and provides backlighting in order to properly scan transparent slide and negative images. (It may also be used as a light box for viewing slides.)

## Y

## Z

*zoom scan*

The ability to enlarge, or magnify, the image in the Preview area so that finer adjustments can be made to the image. This action does not enlarge the picture that is saved, printed, copied to the clipboard, or dragged into another program.

# Index

## A

About HP Precisionscan Pro command 112  
 abrasive cleaners, avoiding 105, 106  
 accessories  
   troubleshooting 100  
   using 75  
 accuracy, OCR 73  
 acquiring scans 71  
 active program, definition 118  
 adapter, transparency. *See* XPA  
 additional pages, prompt for 36  
 ADF (automatic document feeder)  
   capacity 101  
   cleaning 106  
   document specifications 16  
   feeding problems 101  
   jams, clearing 102, 104  
   jams, preventing 101  
   loading 76  
   models including 3  
   Scan dialog box 76  
   scanning from 76  
   troubleshooting 101  
 Adjust Black & White Threshold command  
   shortcuts 111  
   using 58  
 Adjust Color command  
   shortcuts 111  
   using 56  
 Adjust Exposure command  
   shortcuts 111  
   transparent items 81  
   using 50, 51, 52  
 adjusting  
   black and white threshold 58  
   brightness 50  
   color channels 59  
   contrast 46  
   highlights 51  
   hue 56  
   midtones 50  
   output levels 54  
   preferences for scanner buttons 34

  preferences for scanning software 68  
   saturation 57  
   shadows 52  
   tonal resolution 71  
 Adobe Acrobat Reader 63  
   *See also* .pdf files  
 Advanced menu, shortcuts for 111  
 alarms, highlight and shadow 53  
 alcohol, cleaning with 105, 106  
 alerts  
   highlight 53  
   shadow 53  
   Smart Friends 40  
 aliasing, definition 118  
 anti-aliasing, definition 118  
 applications. *See* programs  
 approximate size  
   definition 118  
   files 115  
 Area to scan options 36  
 areas, selecting  
   automatic 70  
   using cursor 42  
 ASCII text, saving as 63  
 attaching files to e-mail 30, 36  
 automatic cropping, definition 119  
 automatic document feeder. *See* ADF  
 automatic exposure adjustment 70  
 automatic resolution 119  
 Automatically Set Type  
   option 43  
   shortcut 111

## B

b&w copy button 25  
 balance, color  
   adjusting 56  
   definition 120  
 bed, scanner  
   definition 129  
   printing entire 64  
   selecting entire 42  
 best quality settings 69  
 bit depth, definition 119

bitmap files (.bmp)  
   definition 119  
   using 63  
 black and white bitmaps  
   adjusting colors in 59  
   definition 119  
   shortcut for 111  
 black and white copies, making 33  
 black and white images  
   inverting colors 49  
   output types for 44  
 black and white scalable  
   definition 119  
   shortcut for 111  
 black and white threshold  
   changing 58  
   definition 119  
 black areas, adjusting 52  
 black eyedropper tool 52  
 black images, troubleshooting 92  
 black output levels, changing 54  
 blank pages, troubleshooting 92, 94  
 blue color channel 59  
 blurry images  
   sharpening 48  
   troubleshooting 91  
 .bmp files (bitmap)  
   definition 119  
   using 63  
 books, scanning pages from 15  
 borders, selection 42  
 boxes, around slides or negatives 95  
 brightness  
   adjusting 50  
   definition 119  
 bulbs, broken 100  
 business cards, scanning 15  
 Button Options dialog box 34  
 buttons. *See* scanner buttons

## C

Cancel button 25  
 capacity, ADF 101  
 carbon paper, scanning 15, 16  
 CDs, scanning to 66

Change Resolution command  
   shortcuts 111  
   using 46  
 changing. *See* adjusting  
 characters, incorrect 96  
 checklist, troubleshooting 85  
 cleaning  
   ADF 106  
   scanner 105  
   XPA 106  
 clearing ADF jams 102, 104  
 click, definition 120  
 clipped pixels  
   checking for 53  
   definition 120  
 CMYK, definition 120  
 collating copies 33  
 color balance  
   adjusting 56  
   definition 120  
 color channels  
   changing 59  
   definition 120  
 color copies, making 33  
 Color copy button 25  
 color correction  
   automatic 70  
   definition 120  
   highlights, adjusting 51  
   hue, adjusting 56  
   midtones, adjusting 50  
   saturation, adjusting 57  
   shadows, adjusting 52  
 color depth  
   definition 120  
   output types 43  
 color images, output types for 44  
 color wheel  
   adjusting hue 56  
   definition 120  
 colored paper  
   adjustments for 59  
   copying from 94

- colors
  - automatic adjustment 70
  - converting to black and white 59
  - highlights, adjusting 51
  - hue, adjusting 56
  - inverting 49
  - midtones, adjusting 50
  - negatives, troubleshooting 95
  - output types 43
  - RGB values, viewing 55
  - saturation, adjusting 57
  - shadows, adjusting 52
  - slides, troubleshooting 95
  - tonal resolution 71
  - troubleshooting 92, 94
- comparison, features 3
- compressed file formats 63
- Configuration dialog box, opening 34
- Contents, Help topics 112
- context-sensitive Help
  - See also Help, online
  - shortcuts 112, 113
  - using 40
- contrast
  - adjusting 46
  - definition 120
- control range, definition 120
- Controls tab options 71
- converting text. See OCR
- copies, making
  - quality, troubleshooting 93
  - troubleshooting 98
  - using HP Copy Utility 14
  - using scanner button 33
- Copy button
  - using 33
- Copy command
  - shortcuts 110, 113
  - using 65
- Copy Utility, HP 14
- copying and pasting
  - toolbar shortcut 113
  - using Clipboard 65
- correction, color
  - automatic 70
  - definition 120
  - highlights, adjusting 51
  - hue, adjusting 56
  - midtones, adjusting 50
  - saturation, adjusting 57
  - shadows, adjusting 52
- cover, scanner 129
- crooked images, troubleshooting 92
- crooked pages, troubleshooting 101
- cropping
  - definition 121
  - scanning area 42
- Current OCR Language option 70
- cursors
  - black eyedropper 52
  - context-sensitive 116
  - dragging and dropping 65
  - Ready 116
  - Selection Area 116
  - Typing 116
  - white eyedropper tool 51
- customer support, resources for 107
- customizing
  - preferences for scanning software 68
  - resolution values 70
  - scanner buttons 34
  - settings 68
- cut off pages, troubleshooting 94
- D**
  - dark areas
    - adjusting 52
    - troubleshooting 91
  - darkening images 50
  - dashed boxes 95
  - decreasing
    - details for transparent items 82
    - details in dark areas 52
    - details in light areas 51
    - saturation 57
  - default programs, changing 34, 96
  - default settings
    - definition 121
    - returning to 48
    - scanner buttons, changing 34
  - deleting selection areas 42
  - density, definition 121
  - depth, color
    - definition 120
    - output types 43
  - Descreen command
    - shortcuts 111
    - using 60
  - desktop, dragging and dropping to 66
  - destinations
    - defined 26
    - E-mail button options 35
    - scanning to 27
    - select button 24
    - troubleshooting 97
  - details
    - black and white threshold 58
    - clipped, checking for 53
    - decreasing in dark areas 52
    - decreasing in light areas 51
    - enhancing 52
    - increasing in dark areas 52
    - increasing in light areas 51
  - device driver, definition 121
  - .dib files (device independent bitmaps) 117
  - dimensions
    - paper sizes 15, 16
    - resizing images 45
  - Disable All Smart Friends 40, 112
  - display resolution
    - definition 121
    - image quality 21
    - output types for 44
  - distribution, pixel 56
  - dithering, definition 121
  - dock, definition 121
  - documentation, printing 13
  - documents, definition 121
  - dots per inch (dpi), definition 121
    - See also resolution
  - dots, troubleshooting 91
  - double-click, definition 121
  - dpi (dots per inch), definition 121
    - See also resolution
  - dragging and dropping
    - between programs 65
    - definition 122
    - to desktop 66
  - drawings, output types for 44
- E**
  - edges not printing 93
  - Edit menu, shortcuts for 110
  - editable text
    - accuracy of 73
    - definition 122
    - languages 70
    - options for 70
    - output types for 44
    - troubleshooting 96
  - Editable Text (OCR) option, shortcut for 111
  - 8-bit grayscale, definition 117
  - E-mail button
    - identifying 24
    - options 35
    - using 31
  - e-mailing scans
    - attaching files 30
    - file sizes 46
    - supported programs 30
    - troubleshooting 97
    - using scanner buttons 31
  - Enable All Smart Friends 40, 112
  - Enable Scan Another Page Dialog 69
  - End Task 85
  - enhancing details 48, 52
  - error messages 87
  - Exit 110
  - exposure
    - automatic adjustments 70
    - definition 122
  - Extend lamp time out 69
  - eyedropper tools
    - black 52
    - functions of 116
    - viewing RGB values 55
    - white 51
- F**
  - fabric, scanning 15
  - FAQs (frequently asked questions) 20
  - features, scanner models 3
  - feeding problems, ADF 101
  - file formats, types of 63
  - File Open command 88

- file sizes
  - definition 122
  - options 36
  - reducing 21
  - resolution changes 46
  - status bar 115
- files
  - attaching to e-mail 30
  - dragging and dropping 66
  - saving to 62
- film, scanning
  - adjusting colors 81
  - from XPA 48
  - negatives 79
  - slides 77
  - troubleshooting 95
- final scans
  - definition 122
  - options 61
  - selecting areas for 42
- fingerprints, cleaning 105, 106
- flashing palette, definition 127
- FlashPix files (.fpx)
  - definition 122
  - using 63
- flipping images 47
- flowed text
  - definition 123
  - option 70
- focus, definition 123
- folders, dragging and dropping to 66
- font sizes, OCR 73
- formats, file 63
- formatting, text
  - options 70
  - troubleshooting 96
- .fpx files (FlashPix)
  - definition 122
  - using 63
- framed text
  - definition 123
  - option 70
- free websites 28, 64
- frequently asked questions 20
- front panel, definition 123
- frozen programs 85
- fuzzy images
  - sharpening 48
  - troubleshooting 92, 94
- G**
- gamma, definition 123
- GIF files (.gif)
  - definition 123
  - output types for 44
  - using 63
- glass cleaner, using 105, 106
- glass, scanner
  - cleaning 105
  - definition 129
  - loading items on 17
  - preparing documents for 15
- grainy, definition 123
- graphics
  - See also* images
  - cut off 94
  - file formats 63
- Graphics Interchange Format. *See* GIF files
- grayscale
  - 8-bit 117
  - definition 124
  - output type, using 44
  - shortcut for 111
- green color channel 59
- grinding sounds, troubleshooting 88
- Guided Steps
  - hiding or showing 40
  - menu shortcut 110
  - toolbar shortcut 113
- gum-backed paper, scanning 15
- H**
- halftone, definition 124
- handwriting, converting 73
- Height field 45
- height, resizing images 45
- Help, online
  - context-sensitive 40, 112, 113
  - HP Copy Utility 14
  - printing 13
  - shortcuts for 112
  - using 40
- hiding Guided Steps 40
- highlights
  - adjusting 51
  - alarms 53
  - automatic adjustment 70
  - clipped areas, checking for 53
  - definition 124
  - histogram 56
  - transparent items, adjusting for 82
- histograms 56, 124
- Hotmail 30
- HP Copy Utility 14
- HP Photo Printing Quick Reference Guide 29
- HP Precisionscan Pro software
  - customizing settings 68
  - features 39
  - help, using 40
  - keyboard shortcuts 110
  - preferences, setting 68
  - product tour, viewing 13
  - scanning with 41
  - starting 40
  - toolbar shortcuts 113
  - troubleshooting 89
  - uninstalling 107
  - when to use 14
- HP Scanjet Button Options 34
- HP Scanjet on the Web 112
- HP Share-to-Web wizard 28
- HTML file formats
  - definition 124
  - using 63
- hue
  - adjusting 56
  - automatic adjustment 70
  - definition 124
  - keyboard shortcuts 111
- I**
- image quality, troubleshooting 90
- images
  - darkening 50
  - definition 124
  - file formats 63
  - highlights, adjusting 51
  - inverting colors 49
  - lightening 50
  - midtones, adjusting 50
  - mirroring 47
  - output levels, adjusting 54
  - resizing 45
  - rotating 47
  - sending to programs 61
  - shadows, adjusting 52
  - sharpening 48
- Import command 88
- importing scans 71
- increasing
  - details 52
  - image clarity 48
  - saturation 57
- info bar 114, 125
- Info Bar command 110
- input tray, ADF
  - loading 76
  - troubleshooting 101
- insufficient memory, troubleshooting 94
- intensity. *See* saturation
- internal mirror, contaminated 94
- interpolated resolution, definition 125
- Invert Colors command
  - shortcuts 111
  - using 49
- isopropyl alcohol, cleaning with 105, 106
- items
  - loading in ADF 76
  - loading on scanner glass 17
  - preparing 15
- J**
- jagged images
  - definition 125
  - troubleshooting 94
- jaggies, definition 118
- jams, ADF
  - clearing 102, 104
  - preventing 101

JPEG files (.jpg)  
 definition 125  
 output types for 44  
 using 63

**K**

keyboard shortcuts 110  
 keys. *See* scanner buttons

**L**

lamp  
 broken 100  
 stays on 87  
 time out, extending 69  
 turned off 88  
 landscape orientation, definition 126  
 languages, OCR 70  
 large file size, option for 36  
*See also* file sizes  
 launching software 40  
 lid, scanner 129  
 light areas  
 adjusting 51  
 copies, troubleshooting 94  
 scans, troubleshooting 91  
 light bulbs  
 broken 100  
 stay on 87  
 light media, scanning 15  
 light shield  
 negatives 79  
 slides 78  
 light source, XPA 69, 78, 132  
 lightening images 50  
 lines, troubleshooting 91, 94  
 loading items  
 ADF 76  
 scanner glass 17  
 loading settings 68  
 lock  
 unlocking 87  
 long items, scanning 101

**M**

magazine pages, scanning 16

making copies  
 quality, troubleshooting 93  
 troubleshooting 98  
 using scanner button 33  
 manual, printing 13  
 margins, adjusting for 93  
 Maximum Pixel Depth  
 definition 126  
 option 69  
 memory, insufficient 94  
 menu shortcuts 110  
 menus, troubleshooting 89  
 messages, error 87  
 Microsoft Hotmail 30  
 Microsoft Windows. *See* Windows  
 midtones  
 adjusting 50  
 automatic adjustment 70  
 definition 126  
 range for 50  
 transparent items, adjusting for 81

Mirror command  
 shortcuts 111  
 using 47  
 mirror, contaminated 94  
 mirroring images  
 keyboard shortcuts for 111  
 using tools 47  
 models, features 3  
 Modify, settings 34  
 moiré, definition 126  
 More Options button  
 identifying 25  
 using 34  
 moving selection areas 42  
 multipart forms, scanning 15  
 multiple feeds, troubleshooting 101  
 multiple pages  
 options for 36  
 scanning 69

**N**

negative holder  
 definition 126  
 using 79  
 negative light shield  
 definition 126  
 using 79

negatives  
 adjusting colors 81  
 scanning 79  
 troubleshooting 95  
 XPA (Negatives) 48  
 new documents opening, troubleshooting 98  
 New Scan command  
 shortcuts 110, 113  
 using 41  
 news clippings, scanning 15  
 noise reduction  
 definition 126  
 settings for 69  
 noisy scans, troubleshooting 88  
 normal file size, option for 36  
 not responding, troubleshooting 88  
 NTSC Gray channel 59  
 Number of copies button 25

**O**

OCR  
 accuracy of 73  
 definition 126  
 languages for 70  
 options for 70  
 output types for 44  
 preparing text for 73  
 troubleshooting 96  
 onionskin paper 16  
 online Help. *See* Help, online  
 opening software 40  
 Optical Character Recognition. *See* OCR  
 optical resolution, definition 127  
 optimized palette, definition 117  
 optimized settings 23  
 optional automatic document feeder. *See* ADF  
 optional transparency adapter. *See* XPA  
 options  
 Controls tab 71  
 E-mail button 35  
 preferences, setting 68  
 Resolution 70  
 Scan To button 37  
 scanner button settings 34  
 Scanner tab 69  
 Selection Area tab 70  
 text 70  
 Options button 62

original items  
 loading in ADF 76  
 loading on scanner glass 17  
 preparing 15  
 Original type, options 36  
 output dimensions  
 changing 45  
 definition 127  
 output levels, changing 54  
 output types  
 automatic selection 70  
 menu shortcuts 111  
 optimal resolutions for 46  
 selecting 43  
 unavailable for printing images 64

**P**

pages, multiple  
 options for 36  
 scanning 69  
 Paint files (.pcx) 127  
 Paintbrush files (.pcx) 127  
 palette flashing, definition 127  
 palettes  
 definition 127  
 optimized 117  
 system 131  
 web 117  
 paper  
 loading in ADF 76  
 sizes, ADF 16  
 sizes, scanner glass 15  
 types of 15  
 paper jams, ADF  
 clearing 102, 104  
 preventing 101  
 Paste command 65  
 pasting images 65  
 patterns, descreening 60  
 PC fax programs, definition 127  
 PC Paintbrush files (.pcx) 127  
 .pcx files (Paintbrush) 127  
 .pdf files  
 multiple pages, scanning to 36  
 printing documentation 13  
 uses for 63  
 percentages, scaling 45  
 Photo Printing Quick Reference Guide 29



- Photo Reprint button
    - identifying 24
    - using 29
  - photos
    - inverting colors 49
    - output types for 44
    - quality options 36
    - troubleshooting 92
  - pink images, troubleshooting 95
  - pixel color
    - transparent items 83
    - viewing 55
  - pixel depth, options for 69
  - pixel, definition 127
  - pixels per inch (PPI), definition 128
  - platforms, file types for 63
  - PNG files (.png) 63
  - pointers. *See* cursors
  - portable network graphics (.png) 63
  - portrait orientation, definition 128
  - positioning plate, XPA
    - definition 128
    - negatives 79
    - slides 77
  - posting scans, definition 128
  - Power Save button 25
  - power, reconnecting 85
  - PPI (pixels per inch), definition 128
  - Precisionscan Pro software. *See* HP Precisionscan Pro software
  - Preferences
    - for scanner buttons 34
    - for scanning software 68
    - menu command 110
  - preparing originals 15
  - preview window, definition 128
  - previewing scans
    - options for 69
    - toolbar shortcut 113
    - using HP Precisionscan Pro software 41
  - Print command
    - shortcuts 110, 113
    - using 64
  - Print Setup 110
  - printing
    - copies 33
    - documentation 13
    - from HP Copy Utility 14
    - resolutions for 128
    - scans 64
    - toolbar shortcuts for 113
    - troubleshooting 98
  - problems, solving. *See* troubleshooting
  - Product Tour command 112
  - product tour, viewing 13
  - programs
    - scanning from 71
    - scanning to 27
    - sending to 61
    - troubleshooting 88
  - progress bar 115
  - progressive JPEG files 63
  - Prompt to scan additional pages 36
  - Properties, Windows Desktop 65
- Q**
- quality, e-mail options 36
  - quality, troubleshooting
    - copies 93
    - scanned images 90
- R**
- raster, definition 128
  - Reader, Adobe Acrobat 63
    - See also* .pdf files
  - readouts, tonal resolution 71
  - Ready cursor 116
  - receipts, scanning 15
  - red color channel 59
  - red line, histogram 56
  - reflecting images 47
  - removing selection areas 42
  - reprints, photo 29
  - resetting
    - all adjustments 48
    - output types 44
    - resolution 46
  - Resize command
    - shortcuts 111
    - using 45
  - resizing
    - images 45
    - keyboard shortcuts for 111
    - selection areas 42
    - troubleshooting 21
  - resolution
    - automatic 21
    - changing 46
    - definition 129
    - interpolated 125
    - optical, definition 127
    - options 36
    - print vs. screen 21
    - printers 128
    - range of values 70
    - screen, definition 130
    - troubleshooting 92
  - Resolution tab options 70
  - Return Image to command
    - shortcuts 110, 113
    - using 72
  - reversing images
    - color 49
    - layout 47
  - rewritable CDs, scanning to 66
  - RGB values
    - definition 129
    - transparent items 83
    - viewing 55
  - rich text format (.rtf)
    - definition 129
    - using 63
  - right-click, definition 129
  - Rotate Left command
    - shortcuts 111, 113
    - using 47
  - Rotate Right command
    - shortcuts 111, 113
    - using 47
  - rotating images
    - keyboard shortcuts for 111
    - toolbar shortcut 113
    - using HP Precisionscan Pro software 47
  - .rtf (rich text format)
    - definition 129
    - using 63
- S**
- saturation
    - adjusting 57
    - automatic adjustment 70
    - definition 129
    - keyboard shortcuts 111
  - Save As command, shortcuts 110, 113
  - saving custom settings 68
  - saving to files
    - formats 63
    - toolbar shortcuts 113
    - using HP Precisionscan Pro software 62
  - scalable images, file formats 63
  - Scale field 45
  - scale, definition 129
  - scaling images 45
  - Scan in color option 36
  - Scan menu, shortcuts for 110
  - Scan To button
    - identifying 24
    - options 37
    - using 26, 27
  - Scan to CD
    - shortcuts 110, 113
    - using 66
  - Scan To command
    - shortcuts 110, 113
    - using 61, 64
  - Scan using channel 59
  - Scanjet Button Options 34
  - Scanjet on the Web 112
  - scanner bed
    - definition 129
    - printing entire 64
    - selecting entire 42
  - scanner buttons
    - identifying 24
    - models including 3
    - settings 34
    - troubleshooting 89
    - when to use 14, 23
  - scanner glass
    - cleaning 105
    - definition 129
    - loading items 17
    - preparing documents for 15
    - Scanner Glass command 48

- Scanner Glass command
    - shortcuts 110
    - using 48
  - scanner lamp. *See* lamp
  - Scanner tab options 69
  - scanning
    - destinations, defined 26
    - loading items 17
    - methods for 14
    - negatives 79
    - preparing originals 15
    - previewing 41
    - selecting areas for 42
    - sending to programs 61
    - slides 77
    - using ADF 76
    - using HP Precisionscan Pro software 41
    - using scanner buttons 23
  - scratched templates 95
  - screen resolution
    - definition 130
    - image quality 21
    - output types for 44
  - Search, Help topics 112
  - Select All 42, 110
  - Select Destination button 24, 99
  - selecting
    - output types 43
    - scanning area 42
  - Selection Area tab options 70
  - selection areas
    - automatic 70
    - cursors 116
    - moving 42
    - negatives 81
    - removing border 42
    - resizing 42
    - slides 81
    - zooming to 43
  - self-test errors 87
  - sending to programs
    - directions for 61
    - troubleshooting 98
  - Set as Wallpaper 65
  - settings
    - Controls tab 71
    - custom, saving 68
    - E-mail button 35
    - for scanning software 68
    - loading 68
    - optimized 23
    - resetting adjustments 48
    - Resolution tab 70
    - saving 68
    - Scan To button 37
    - scanner buttons 34
    - Scanner tab 69
    - Selection Area tab 70
    - shortcut for 110
    - Text tab 70
  - shadows
    - adjusting 52
    - alarms 53
    - automatic adjustment 70
    - clipped areas, checking for 53
    - definition 130
    - histogram 56
  - Share-to-Web button
    - locating 24
    - using 28
  - Sharpen command
    - shortcuts 111
    - using 48
  - sharpening
    - definition 130
    - images 48
    - keyboard shortcuts for 111
    - options for 69
  - shield, light
    - negatives 79
    - slides 78
  - shortcuts
    - keyboard 110
    - menu 110
    - toolbar 113
  - showing Guided Steps 40
  - size
    - See also* file sizes
    - image, troubleshooting 92, 93
    - paper, ADF 16
    - resizing images 45
    - transparent media 16
  - skewed images, troubleshooting 92
  - skewed pages, troubleshooting 101
  - slide holder
    - definition 130
    - using 78
  - slide light shield
    - definition 130
    - using 78
  - slides
    - adjusting colors 81
    - scanning 77
    - troubleshooting 95
    - viewing 78
    - XPA (Slides) 48
  - slow scanning, troubleshooting 20, 89
  - small file size, option for 36
    - See also* file sizes
  - Smart Friends tips 40
  - software. *See* HP Precisionscan Pro software
  - software programs. *See* programs
  - solving problems. *See* troubleshooting
  - source documents. *See* original items
  - source, definition 130
  - specifications
    - ADF 16
    - scanner glass media 15
  - speed, troubleshooting 20, 89
  - spot color
    - definition 130
    - shortcut for 111
    - using output type 44
  - Start button, definition 130
  - starting scans
    - methods for 14
    - using HP Precisionscan Pro software 41
    - using scanner buttons 23
    - using TWAIN 71
  - status bar 115, 130
  - Status Bar command 110
  - streaks, troubleshooting 91
  - stripes, troubleshooting 94
  - support, resources for 107
  - supported programs
    - e-mail 30
    - TWAIN 71
    - WIA 72
  - system palette, definition 131
- T**
- tab options
    - Control 71
    - Resolution 70
    - Scanner 69
    - Selection Area 70
    - Text 70
  - Tagged Image File Format. *See* TIFF files
  - Taskbar, definition 131
  - templates
    - negative 79
    - slides 77
    - troubleshooting 95
  - Text and Image 111
  - Text tab options 70
  - text, editable
    - accuracy of 73
    - languages 70
    - options for with HP scanning software 70
    - output types for 44
    - troubleshooting 96
  - textured paper, scanning 15
  - threshold, black and white 58
  - thresholding, definition 131
  - TIFF compressed, definition 131
  - TIFF files (.tif)
    - definition 131
    - using 63, 67
  - time out, lamp 69
  - tips, Smart Friends 40
  - tonal resolution, adjusting 71
  - tone, definition 131
  - Tool Bar command 110
  - toolbar
    - adding tools 114
    - shortcuts 113
  - tools
    - adding to toolbar 114
    - black eyedropper 52
    - viewing functions of 40
    - white eyedropper 51
  - Tools menu, shortcuts for 111

## transparency adapter (XPA)

- cleaning 106
- light source 69, 78, 132
- media sizes 16
- models including 3
- negatives, scanning 79
- scanning from 77
- slides, scanning 77
- troubleshooting 95, 100
- XPA command 48

trays. *See* input tray, ADF

## troubleshooting

- ADF 101
- checklist 85
- copies 93
- e-mailing 97
- frequently asked questions 20
- HP Precisionscan Pro software 89
- image quality 90
- negatives 95
- OCR 96
- scanner buttons 89
- scanner not responding 88
- slides 95
- slow scanning 20, 89
- transparencies 95
- TWAIN programs 98
- XPA 100
- zooming 21

## True Color

- definition 131
- shortcut for 111
- using 44

## turquoise line, histogram 56

## TWAIN programs

- definition 131
- returning images to 62
- scanning from 71
- troubleshooting 98

## 24-bit color, definition 117

## 256-Color

- definition 117
- using 44
- shortcut for 111

## Typing cursor 116

## U

underlined text, converting 73

## Undo Editing Changes command

- shortcuts 110, 113
- using 48

## uniform scaling, definition 132

## uninstalling software 107

## unlocking scanner 87, 88

## Unselect All 42, 110

## USB, definition 132

## User's Manual, shortcut to 112

## V

## vector images

- definition 132
- file formats 63

## View menu, shortcuts for 110

## viewing

- product tour 13
- RGB values 55
- slides 78

## W

## wallpaper, setting images as 65

warnings. *See* alerts

## web based e-mail 30

## web graphics, output types 44

## web palette, definition 117

## websites

- free 28, 64
- output types for 44
- scanning items to 28, 64

## weight

- paper specifications, ADF media 16
- paper specifications, scanner glass 15

## What's This 40, 112, 113

## white areas, adjusting 51

## white eyedropper 51

## white images, troubleshooting 92

## white output levels, changing 54

## white stripes, troubleshooting 94

WIA (Windows Imaging Application), scanning  
from 72

## Width field 45

## window cleaner, using 106

## Windows desktop, dragging and dropping to 66

Windows Imaging Application (WIA), scanning  
from 72

## Windows metafiles (.wmf)

- definition 132
- using 63

## wizard, HP Share-to-Web 28

## .wmf (Windows metafiles)

- definition 132
- using 63

## X

## XPA (Negatives) command

- resetting to 48
- shortcuts 110
- using 80

## XPA (optional transparency adapter)

- cleaning 106
- light source 69, 78, 132
- media sizes 16
- models including 3
- negatives, scanning 79
- scanning from 77
- slides, scanning 77
- troubleshooting 95, 100
- XPA command 48

## XPA (Slides) command

- resetting to 48
- shortcuts 110
- using 78

## Z

## Zoom In command

- shortcuts 110, 113
- using 43

## Zoom Out command

- shortcuts 110, 113
- using 43

## zooming

- definition 21
- in 43
- menu shortcuts for 110
- out 43
- toolbar shortcuts for 113
- viewing preview images 43



## Free Manuals Download Website

<http://myh66.com>

<http://usermanuals.us>

<http://www.somanuals.com>

<http://www.4manuals.cc>

<http://www.manual-lib.com>

<http://www.404manual.com>

<http://www.luxmanual.com>

<http://aubethermostatmanual.com>

Golf course search by state

<http://golfingnear.com>

Email search by domain

<http://emailbydomain.com>

Auto manuals search

<http://auto.somanuals.com>

TV manuals search

<http://tv.somanuals.com>