

HP 5120 EI & 5120 SI Switch Series Installation Guide

Part number: 5998-1773

Document version: 6W102-20121111



Legal and notice information

© Copyright 2012 Hewlett-Packard Development Company, L.P.

No part of this documentation may be reproduced or transmitted in any form or by any means without prior written consent of Hewlett-Packard Development Company, L.P.

The information contained herein is subject to change without notice.

HEWLETT-PACKARD COMPANY MAKES NO WARRANTY OF ANY KIND WITH REGARD TO THIS MATERIAL, INCLUDING, BUT NOT LIMITED TO, THE IMPLIED WARRANTIES OF MERCHANTABILITY AND FITNESS FOR A PARTICULAR PURPOSE. Hewlett-Packard shall not be liable for errors contained herein or for incidental or consequential damages in connection with the furnishing, performance, or use of this material.

The only warranties for HP products and services are set forth in the express warranty statements accompanying such products and services. Nothing herein should be construed as constituting an additional warranty. HP shall not be liable for technical or editorial errors or omissions contained herein.

Contents

Product overview	1
5120-24G EI (2 slots)/5120-24G EI TAA (2 slots) panel views	2
5120-48G EI (2 slots)/5120-48G EI TAA (2 slots) panel views	3
5120-24G EI panel views	4
5120-48G EI panel views	5
5120-24G-PoE+ EI (2 slots)/5120-24G-PoE+ EI TAA (2 slots) panel views	6
5120-48G-PoE+ EI (2 slots)/5120-48G-PoE+ EI TAA (2 slots) panel views	7
5120-8G SI panel views	8
5120-16G SI panel views	8
5120-24G SI panel views	9
5120-48G SI panel views	9
5120-8G-PPoE+ SI panel views	10
5120-8G-PoE+ SI panel views	10
5120-24G-PPoE+ SI panel views	11
5120-24G-PoE+ SI panel views	12
Preparing for installation	13
Safety recommendations	13
Examining the installation site	13
Temperature/humidity	13
Cleanness	14
EMI	14
Laser safety	14
Installation tools	15
Installing the switch	16
Installing a 5120 EI switch in a 19-inch rack	17
Mounting brackets	17
Rack-mounting by using only front mounting brackets	18
Rack-mounting by using front mounting brackets and a rack shelf	20
Rack-mounting by using front and rear mounting brackets	21
Installing a 5120 SI switch in a 19-inch rack	24
Mounting brackets and mounting positions	25
Attaching the mounting brackets to the switch chassis	25
Rack-mounting the switch	28
Mounting the switch on a workbench	30
Mounting the switch to a wall	30
Introduction to wall anchor kit	31
Installation procedure	31
Mounting the switch through magnet mounting	32
Introduction to magnetic mounting kit	32
Installation procedure	33
Grounding the switch	34
Grounding the switch with a grounding strip	34
Grounding the switch with a grounding conductor buried in the earth ground	36
Grounding the switch by using the AC power cord	37
Connecting the power cord	38
Connecting the AC power cord	38
Connecting the switch to a +12 VDC output RPS	39
Connecting the switch to a -52 to -55 VDC output RPS	40

Installing/removing an interface card (only for the 5120 EI switches).....	41
Installing an interface card.....	41
Removing an interface card.....	42
Installing/removing a dedicated CX4/SFP+ cable.....	42
Verifying the installation.....	43
Accessing the switch for the first time.....	44
Setting up the configuration environment.....	44
Connecting the console cable.....	44
Console cable.....	44
Connection procedure.....	44
Setting terminal parameters.....	45
Powering on the switch.....	48
Verification before power-on.....	48
Powering on the switch.....	48
Changing the startup mode.....	50
Setting up an IRF fabric.....	53
IRF fabric setup flowchart.....	53
Planning IRF fabric setup.....	54
Planning IRF fabric size and the installation site.....	54
Identifying the master switch and planning IRF member IDs.....	54
Planning IRF topology and connections.....	55
Identifying physical IRF ports on the member switches.....	56
Planning the cabling scheme.....	57
Configuring basic IRF settings.....	59
Connecting the physical IRF ports.....	60
Accessing the IRF fabric to verify the configuration.....	60
Maintenance and troubleshooting.....	61
Password loss.....	61
Console login password loss.....	61
Boot ROM password loss.....	61
Power supply failure.....	61
Fan failure (only for the 5120 EI switches).....	63
Configuration terminal problems.....	63
Appendix A Technical specifications.....	64
Physical specifications.....	64
Chassis dimensions and weights.....	64
Ports and interface card slots.....	64
Environmental specifications.....	65
Power specifications.....	65
Power input types.....	65
AC input voltage specifications.....	66
RPS DC input voltage specifications and RPS compatibility.....	66
Power consumption specifications for non-PoE switches.....	66
Power consumption specifications for PoE switches.....	67
Cooling system.....	67
Appendix B FRUs and compatibility matrixes.....	69
Interface cards (only for the 5120 EI switches).....	69
SFP/SFP+/XFP transceiver modules and SFP+/CX4 cables (only for the 5120 EI switches).....	69
GE SFP transceiver modules.....	70
10-GE SFP+ transceiver modules.....	70
SFP+ cables.....	71
10-GE XFP transceiver modules.....	72

CX4 cables.....	72
SFP transceiver modules and SFP Stacking Kit (only for the 5120 SI switches).....	73
Appendix C Ports and LEDs	75
Ports	75
Console port.....	75
10/100/1000Base-T Ethernet port	75
SFP port	75
Combo interface (only available on the 5120 EI switches).....	76
LEDs (for the 5120 EI switches)	76
System status LED.....	76
RPS status LED.....	77
Port mode LED.....	77
Seven-segment LED.....	77
10/100/1000Base-T Ethernet port LED.....	79
SFP port LED.....	79
Interface card status LED.....	80
LEDs (for the 5120 SI switches)	80
Power LED	80
RPS status LED	81
Port mode LED.....	81
10/100/1000Base-T Ethernet port LED.....	81
1000Base-X SFP port LED.....	83
Support and other resources	84
Contacting HP	84
Subscription service	84
Related information	84
Documents.....	84
Websites.....	84
Conventions	85
Index	87

Product overview

The HP 5120 EI Switch Series includes the models in [Table 1](#), and the HP 5120 SI Switch Series includes the models in [Table 2](#).

Table 1 Models in the HP 5120 EI Switch Series

Type	Product code	HP description	Alias
Non-PoE	JE066A	HP 5120-24G EI Switch	5120-24G EI
	JE067A	HP 5120-48G EI Switch	5120-48G EI
	JE068A	HP 5120-24G EI Switch with 2 Interface Slots	5120-24G EI (2 slots)
	JG245A	HP 5120-24G EI TAA Switch with 2 Interface Slots	5120-24G EI TAA (2 slots)
	JE069A	HP 5120-48G EI Switch with 2 Interface Slots	5120-48G EI (2 slots)
	JG246A	HP 5120-48G EI TAA Switch with 2 Interface Slots	5120-48G EI TAA (2 slots)
PoE	JG236A	HP 5120-24G-PoE+ EI Switch with 2 Interface Slots	5120-24G-PoE+ EI (2 slots)
	JG247A	HP 5120-24G-PoE+ EI TAA Switch with 2 Interface Slots	5120-24G-PoE+ EI TAA (2 slot)
	JG237A	HP 5120-48G-PoE+ EI Switch with 2 Interface Slots	5120-48G-PoE+ EI (2 slots)
	JG248A	HP 5120-48G-PoE+ EI TAA Switch with 2 Interface Slots	5120-48G-PoE+ EI TAA (2 slots)

Table 2 Models in the HP 5120 SI Switch Series

Type	Product code	HP description	Alias
Non-PoE	JE073A	HP 5120-16G SI Switch	5120-16G SI
	JE074A	HP 5120-24G SI Switch	5120-24G SI
	JE072A	HP 5120-48G SI Switch	5120-48G SI
	JG308A	HP 5120-8G SI Switch	5120-8G SI
PoE	JG092A	HP 5120-24G-PPoE+ SI Switch	5120-24G-PPoE+ SI
	JG091A	HP 5120-24G-PoE+ SI Switch	5120-24G-PoE+ SI
	JG310A	HP 5120-8G-PPoE+ SI Switch	5120-8G-PPoE+ SI
	JG309A	HP 5120-8G-PoE+ SI Switch	5120-8G-PoE+ SI

! IMPORTANT:

For regulatory identification purposes, the HP 5120-8G SI, HP 5120-8G-PPoE+ SI, and HP 5120-8G-PoE+ SI products are assigned Regulatory Model Numbers (RMN). The Regulatory Model Numbers for these products are listed below. These regulatory numbers should not be confused with the marketing names HP 5120, or product numbers JG308A, JG310A, and JG309A.

Table 3 Regulatory Model Numbers in the HP 5120 8G SI Switch Series

Product code	RMN	HP description
JG308A	BJNGA-AD0006	HP 5120-8G SI Switch
JG310A	BJNGA-AD0007	HP 5120-8G-PPoE+ SI Switch
JG309A	BJNGA-AD0008	HP 5120-8G-PoE+ SI Switch

This chapter describes the chassis panel views of the 5120 EI and 5120 SI switches.

5120-24G EI (2 slots)/5120-24G EI TAA (2 slots) panel views

Figure 1 Front panel

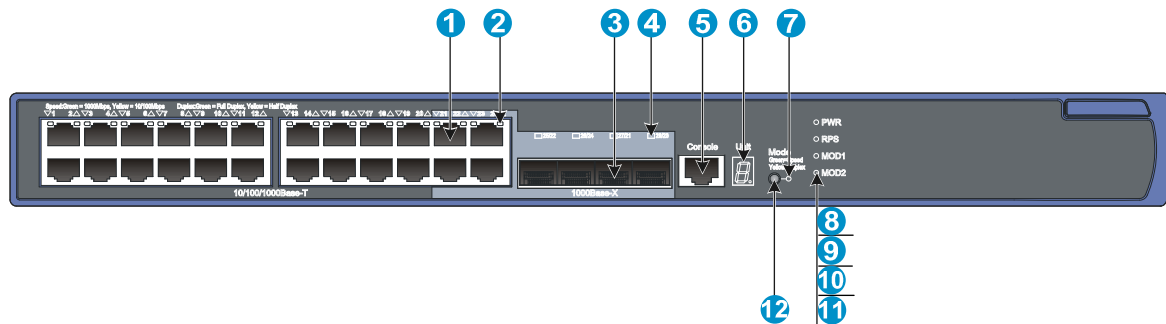

- | | |
|--------------------------------------------------|-----------------------------------------|
| (1) 10/100/1000Base-T auto-sensing Ethernet port | |
| (2) 10/100/1000Base-T Ethernet port LED | |
| (3) 1000Base-X SFP port | (4) 1000Base-X SFP port LED |
| (5) Console port | (6) Seven-segment LED (Unit) |
| (7) Port mode LED (Mode) | (8) System status LED (PWR) |
| (9) RPS status LED (RPS) | (10) Interface card 1 status LED (MOD1) |
| (11) Interface card 2 status LED (MOD2) | (12) Port LED mode switching button |

Figure 2 Rear panel

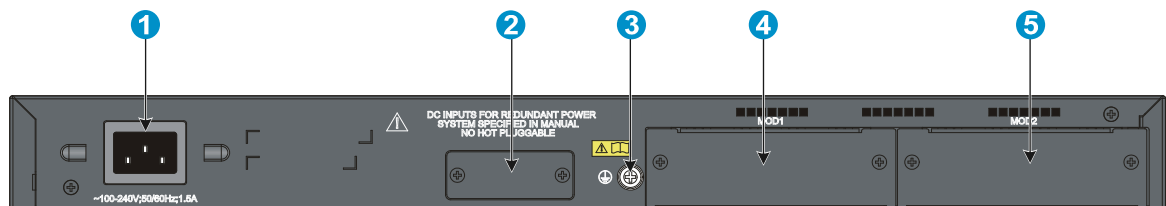

- | | |
|-------------------------------|------------------------------------------------------|
| (1) AC-input power receptacle | (2) RPS receptacle (shipped with a protective cover) |
|-------------------------------|------------------------------------------------------|

(3) Grounding screw

(4) Interface card slot 1 (MOD1)

(5) Interface card slot 2 (MOD2)

NOTE:

The 5120-24G EI (2 slots) and 5120-24G EI TAA (2 slots) switches come with the expansion interface card slots covered by filler panels.

5120-48G EI (2 slots)/5120-48G EI TAA (2 slots) panel views

Figure 3 Front panel

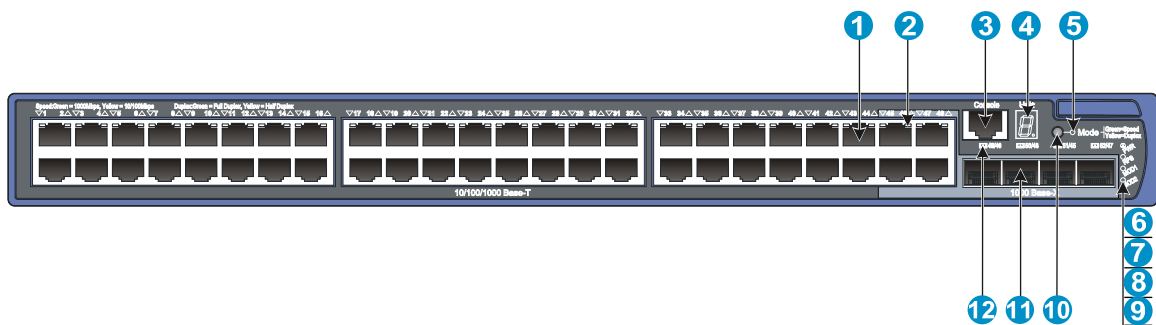

(1) 10/100/1000Base-T auto-sensing Ethernet port

(2) 10/100/1000Base-T Ethernet port LED

(3) Console port

(4) Seven-segment LED (Unit)

(5) Port mode LED (Mode)

(6) System status LED (PWR)

(7) RPS status LED (RPS)

(8) Interface card 1 status LED (MOD1)

(9) Interface card 2 status LED (MOD2)

(10) Port LED mode switching button

(11) 1000Base-X SFP port

(12) 1000Base-X SFP port LED

Figure 4 Rear panel

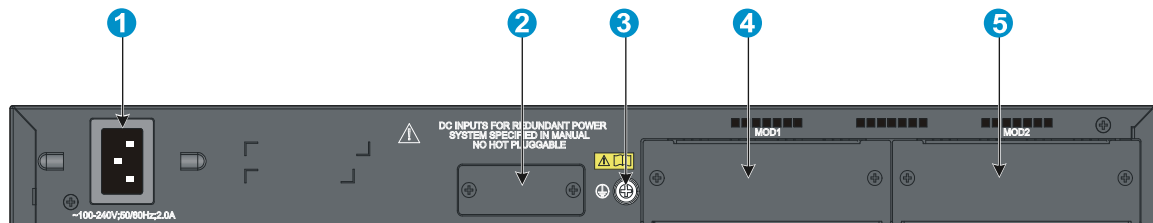

(1) AC-input power receptacle

(2) RPS receptacle (shipped with a protective cover)

(3) Grounding screw

(4) Interface card slot 1 (MOD1)

(5) Interface card slot 2 (MOD2)

NOTE:

The 5120-48G EI (2 slots) and 5120-48G EI TAA (2 slots) switches come with the expansion interface card slots covered by filler panels.

5120-24G EI panel views

Figure 5 Front panel

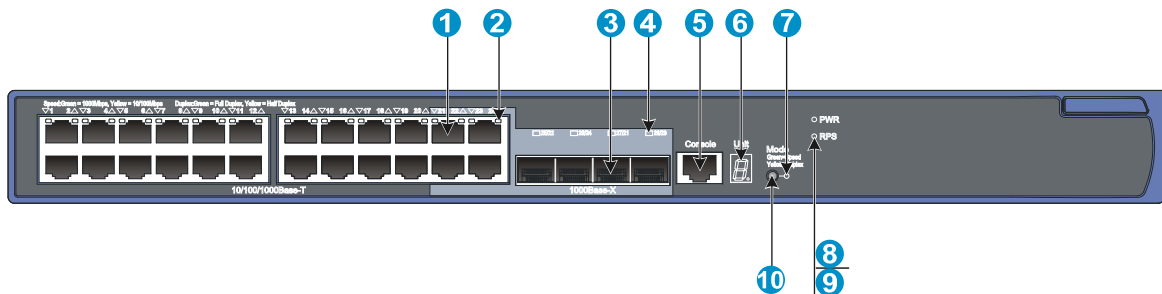

- | | |
|--------------------------------------------------|-----------------------------------------|
| (1) 10/100/1000Base-T auto-sensing Ethernet port | (2) 10/100/1000Base-T Ethernet port LED |
| (3) SFP port | (4) SFP port LED |
| (5) Console port | (6) Seven-segment LED (Unit) |
| (7) Port mode LED (Mode) | (8) System status LED (PWR) |
| (9) RPS status LED (RPS) | (10) Port LED mode switching button |

Figure 6 Rear panel

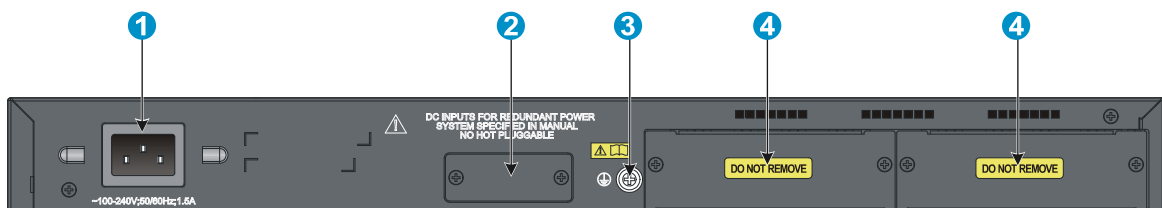

- | | |
|-------------------------------|---------------------------|
| (1) AC-input power receptacle | (2) RPS receptacle |
| (3) Grounding screw | (4) "DO NOT REMOVE" label |

⚠ CAUTION:

The 5120-24G EI switch does not support interface cards. To ensure good ventilation, do not remove the interface card slot filler panels.

5120-48G EI panel views

Figure 7 Front panel

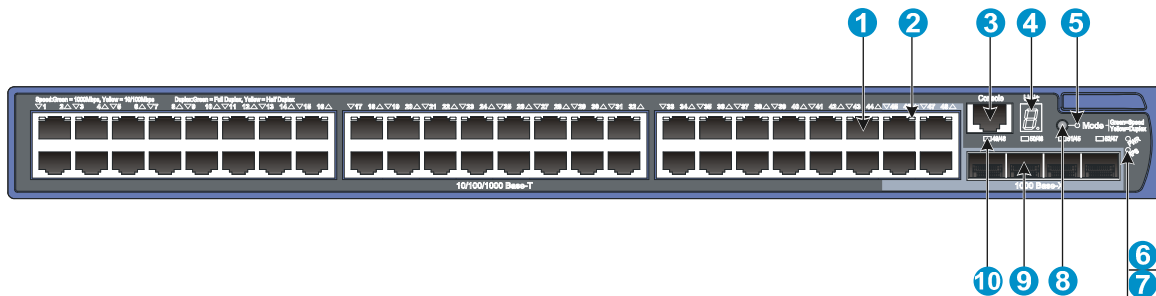

- | | |
|--------------------------------------------------|-----------------------------------------|
| (1) 10/100/1000Base-T auto-sensing Ethernet port | (2) 10/100/1000Base-T Ethernet port LED |
| (3) Console port | (4) Seven-segment LED (Unit) |
| (5) Port mode LED (Mode) | (6) System status LED (PWR) |
| (7) RPS status LED (RPS) | (8) Port LED mode switching button |
| (9) SFP port | (10) SFP port LED |

Figure 8 Rear panel

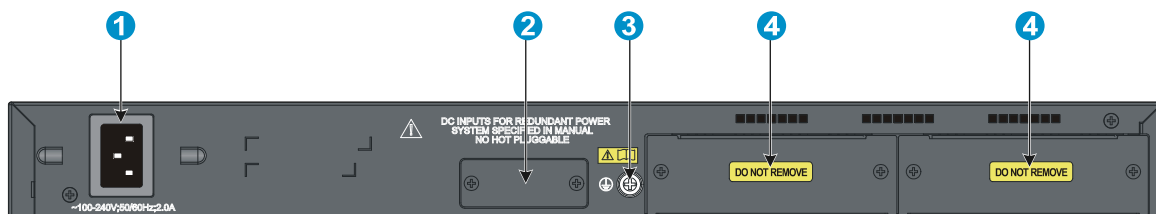

- | | |
|-------------------------------|----------------------------------------|
| (1) AC-input power receptacle | (2) RPS receptacle (with filler panel) |
| (3) Grounding screw | (4) "DO NOT REMOVE" label |



CAUTION:

The 5120-48G EI switch does not support interface cards.

5120-24G-PoE+ EI (2 slots)/5120-24G-PoE+ EI TAA (2 slots) panel views

Figure 9 Front panel

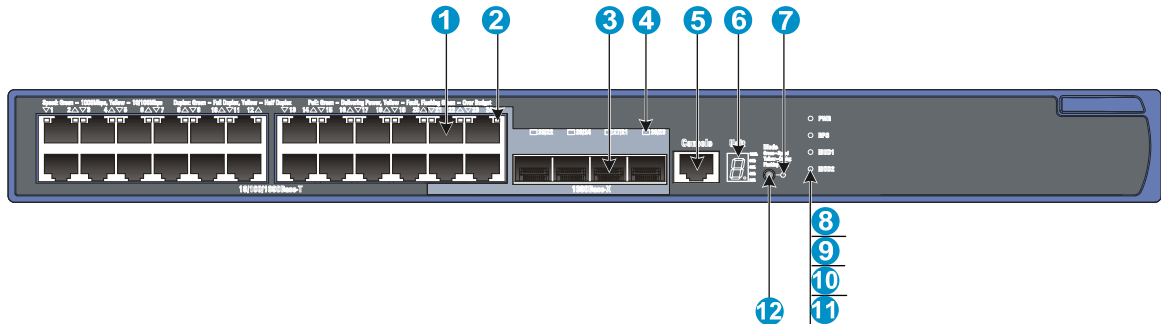

- | | |
|--------------------------------------------------|-----------------------------------------|
| (1) 10/100/1000Base-T auto-sensing Ethernet port | |
| (2) 10/100/1000Base-T Ethernet port LED | |
| (3) 1000Base-X SFP port | (4) 1000Base-X SFP port LED |
| (5) Console port | (6) Seven-segment LED (Unit) |
| (7) Port mode LED (Mode) | (8) System status LED (PWR) |
| (9) RPS status LED (RPS) | (10) Interface card 1 status LED (MOD1) |
| (11) Interface card 2 status LED (MOD2) | (12) Port LED mode switching button |

Figure 10 Rear panel

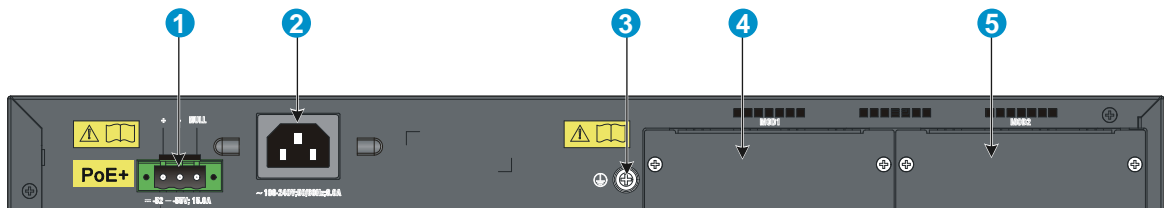

- | | |
|----------------------------------|----------------------------------|
| (1) RPS receptacle | (2) AC-input power receptacle |
| (3) Grounding screw | (4) Interface card slot 1 (MOD1) |
| (5) Interface card slot 2 (MOD2) | |

NOTE:

The 5120-24G-PoE+ EI (2 slots) and 5120-24G-PoE+ EI TAA (2 slots) switches come with the expansion interface card slots covered by filler panels.

5120-48G-PoE+ EI (2 slots)/5120-48G-PoE+ EI TAA (2 slots) panel views

Figure 11 Front panel

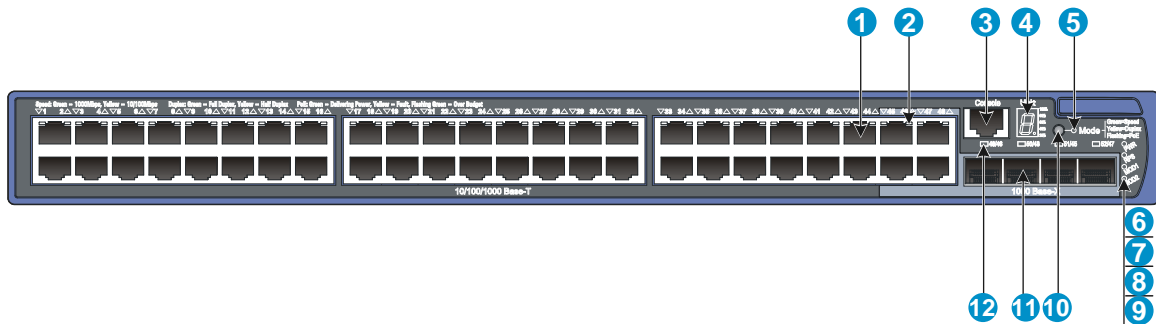

(1) 10/100/1000Base-T auto-sensing Ethernet port	
(2) 10/100/1000Base-T Ethernet port LED	
(3) Console port	(4) Seven-segment LED (Unit)
(5) Port mode LED (Mode)	(6) System status LED (PWR)
(7) RPS status LED (RPS)	(8) Interface card 1 status LED (MOD1)
(9) Interface card 2 status LED (MOD2)	(10) Port LED mode switching button
(11) 1000Base-X SFP port	(12) 1000Base-X SFP port LED

Figure 12 Rear panel

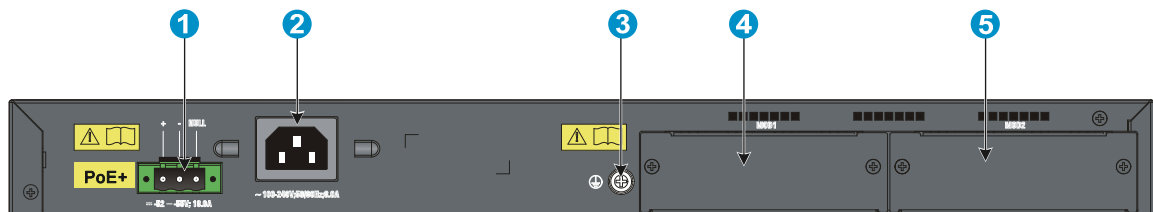

(1) RPS receptacle	(2) AC-input power receptacle
(3) Grounding screw	(4) Interface card slot 1 (MOD1)
(5) Interface card slot 2 (MOD2)	

NOTE:

The 5120-48G-PoE+ EI (2 slots) and 5120-48G-PoE+ EI TAA (2 slots) switches come with the expansion interface card slots covered by filler panels.

5120-8G SI panel views

Figure 13 Front panel

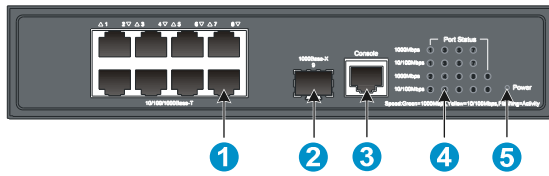

- | | |
|--------------------------------------------------|-------------------------|
| (1) 10/100/1000Base-T auto-sensing Ethernet port | (2) 1000Base-X SFP port |
| (3) Console port | (4) Port LED |
| (5) Power LED (Power) | |

Figure 14 Rear panel



- | | |
|-------------------------------|---------------------|
| (1) AC-input power receptacle | (2) Grounding screw |
|-------------------------------|---------------------|

5120-16G SI panel views

Figure 15 Front panel

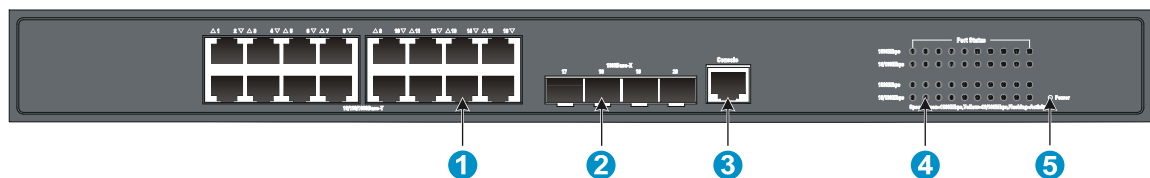

- | | |
|--------------------------------------------------|-------------------------|
| (1) 10/100/1000Base-T auto-sensing Ethernet port | (2) 1000Base-X SFP port |
| (3) Console port | (4) Port LED |
| (5) Power LED (Power) | |

Figure 16 Rear panel



- | | |
|-------------------------------|---------------------|
| (1) AC-input power receptacle | (2) Grounding screw |
|-------------------------------|---------------------|

5120-24G SI panel views

Figure 17 Front panel

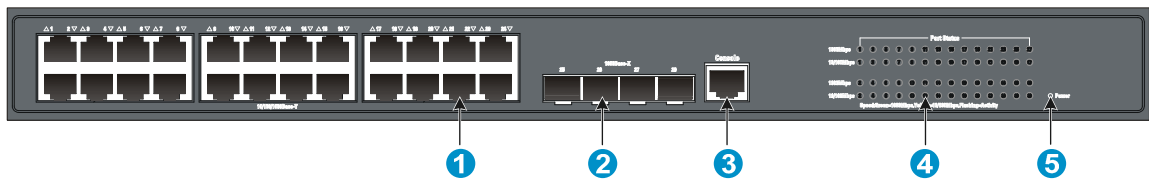

- | | |
|--------------------------------------------------|-------------------------|
| (1) 10/100/1000Base-T auto-sensing Ethernet port | (2) 1000Base-X SFP port |
| (3) Console port | (4) Port LED |
| (5) Power LED (Power) | |

Figure 18 Rear panel



- | | |
|-------------------------------|---------------------|
| (1) AC-input power receptacle | (2) Grounding screw |
|-------------------------------|---------------------|

5120-48G SI panel views

Figure 19 Front panel

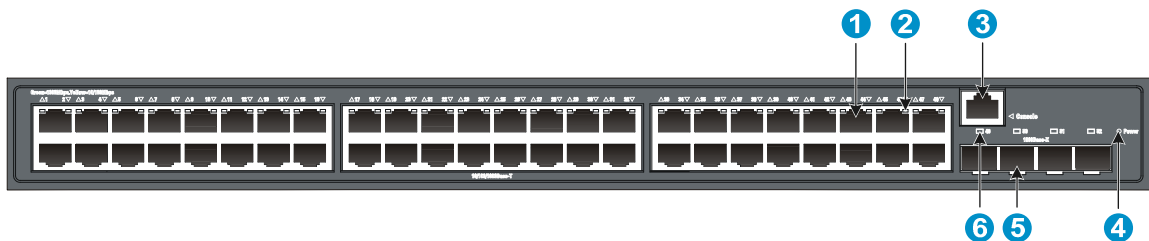

- | | |
|--------------------------------------------------|-----------------------------------------|
| (1) 10/100/1000Base-T auto-sensing Ethernet port | (2) 10/100/1000Base-T Ethernet port LED |
| (3) Console port | (4) Power LED (Power) |
| (5) 1000Base-X SFP port | (6) 1000Base-X SFP port LED |

Figure 20 Rear panel

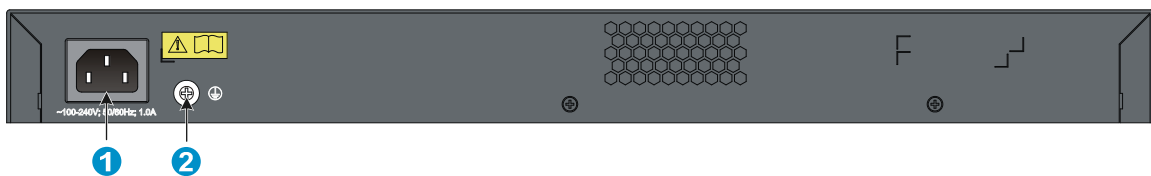

- | | |
|-------------------------------|---------------------|
| (1) AC-input power receptacle | (2) Grounding screw |
|-------------------------------|---------------------|

5120-8G-PPoE+ SI panel views

Figure 21 Front panel

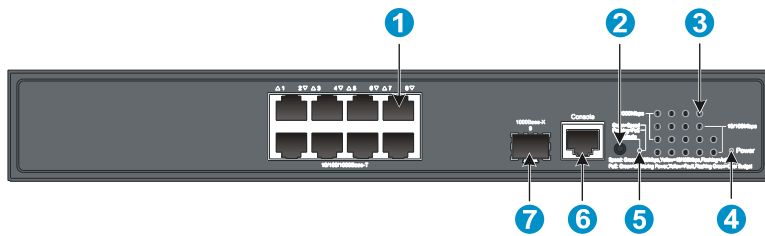

- | | |
|--------------------------------------------------|------------------------------------|
| (1) 10/100/1000Base-T auto-sensing Ethernet port | (2) Port LED mode switching button |
| (3) Port LED | (4) Power LED (Power) |
| (5) Port mode LED | (6) Console port |
| (7) 1000Base-X SFP port | |

Figure 22 Rear panel

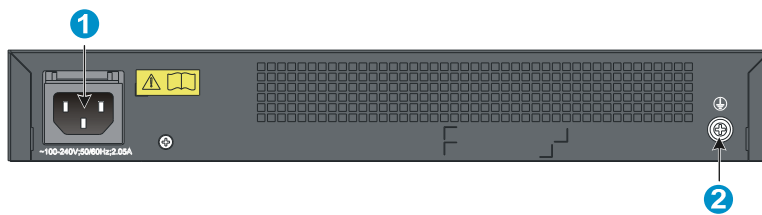

- | | |
|-------------------------------|---------------------|
| (1) AC-input power receptacle | (2) Grounding screw |
|-------------------------------|---------------------|

5120-8G-PoE+ SI panel views

Figure 23 Front panel

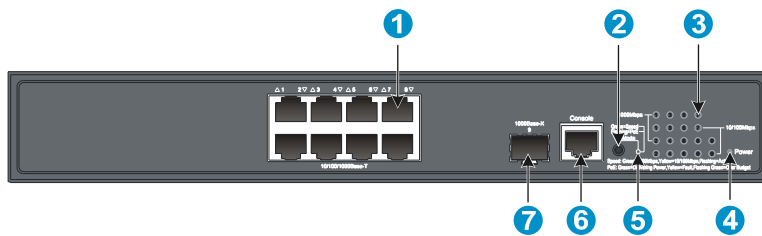

- | | |
|--------------------------------------------------|------------------------------------|
| (1) 10/100/1000Base-T auto-sensing Ethernet port | (2) Port LED mode switching button |
| (3) Port LED | (4) Power LED (Power) |
| (5) Port mode LED | (6) Console port |
| (7) 1000Base-X SFP port | |

Figure 24 Rear panel



(1) AC-input power receptacle

(2) Grounding screw

5120-24G-PPoE+ SI panel views

Figure 25 Front panel

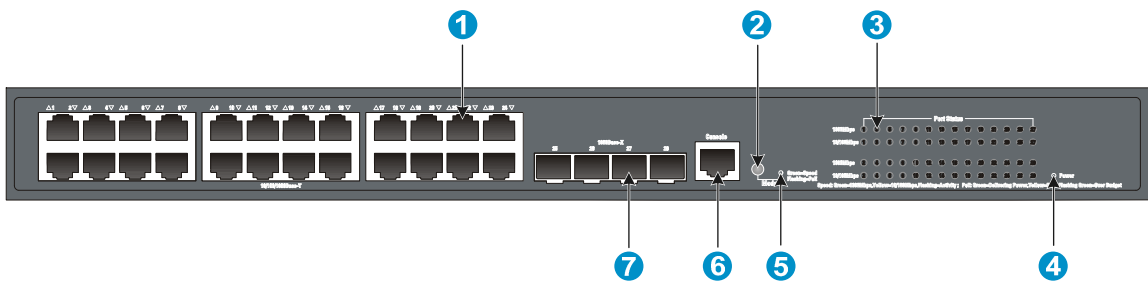

(1) 10/100/1000Base-T auto-sensing Ethernet port

(2) Port LED mode switching button

(3) Port LED

(4) Power LED (Power)

(5) Port mode LED

(6) Console port

(7) 1000Base-X SFP port

Figure 26 Rear panel



(1) AC-input power receptacle

(2) Grounding screw

5120-24G-PoE+ SI panel views

Figure 27 Front panel

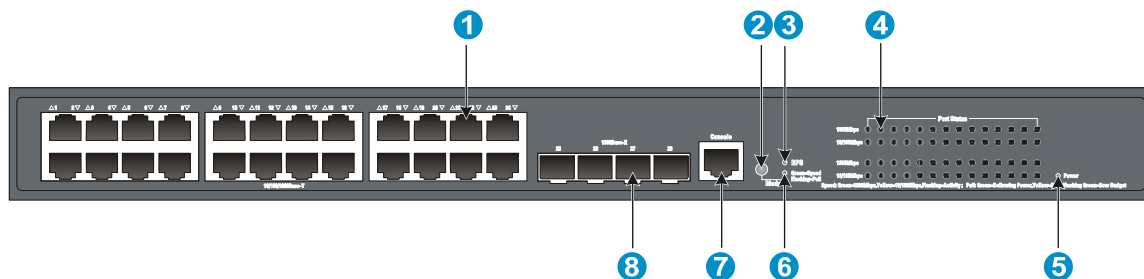

(1) 10/100/1000Base-T auto-sensing Ethernet port	(2) Port LED mode switching button
(3) RPS status LED (RPS)	(4) Port LED
(5) Power LED (Power)	(6) Port mode LED
(7) Console port	(8) 1000Base-X SFP port

Figure 28 Rear panel

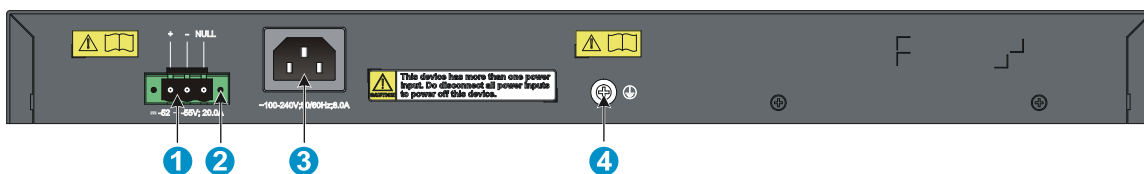

(1) DC receptacle	(2) Screw hole of the plug
(3) AC-input power receptacle	(4) Grounding screw

Preparing for installation

Safety recommendations

To avoid any equipment damage or bodily injury caused by improper use, read the following safety recommendations before installation. Note that the recommendations do not cover every possible hazardous condition.

- Before cleaning the switch, unplug all power cords. Do not clean the switch with wet cloth or liquid.
- Do not place the switch near water or in a damp environment. Prevent water or moisture from entering the switch chassis.
- Do not place the switch on an unstable case or desk. The switch might be severely damaged in case of a fall.
- Ensure proper ventilation of the equipment room and keep the air inlet and outlet vents of the switch free of obstruction.
- Make sure that the operating voltage is in the required range.
- To avoid electrical shocks, do not open the chassis while the switch is operating or when the switch is just powered off.
- When replacing FRUs, wear an ESD-preventive wrist strap to avoid damaging the units.

Examining the installation site

The 5120 EI and 5120 SI switches must be used indoors. You can mount your switch in a rack or on a workbench, but make sure:

- Adequate clearance is reserved at the air inlet and exhaust vents for ventilation.
- The rack or workbench has a good ventilation system.
- The rack is sturdy enough to support the switch and its accessories.
- The rack or workbench is well earthed.

To ensure normal operation and long service life of your switch, install it in an environment that meets the requirements described in the following subsections.

Temperature/humidity

Maintain appropriate temperature and humidity in the equipment room.

- Lasting high relative humidity can cause poor insulation, electricity creepage, mechanical property change of materials, and metal corrosion.
- Lasting low relative humidity can cause washer contraction and ESD and bring problems including loose captive screws and circuit failure.
- High temperature can accelerate the aging of insulation materials and significantly lower the reliability and lifespan of the switch.

For the temperature and humidity requirements, see "[Appendix A Technical specifications.](#)"

Cleanness

Dust buildup on the chassis may result in electrostatic adsorption, which causes poor contact of metal components and contact points, especially when indoor relative humidity is low. In the worst case, electrostatic adsorption can cause communication failure.

Table 4 Dust concentration limit in the equipment room

Substance	Concentration limit (particles/m ³)
Dust	≤ 3 × 10 ⁴ (no visible dust on the tabletop over three days)

NOTE:

Dust diameter ≥ 5 μm

The equipment room must also meet strict limits on salts, acids, and sulfides to eliminate corrosion and premature aging of components, as shown in [Table 5](#).

Table 5 Harmful gas limits in the equipment room

Gas	Maximum concentration (mg/m ³)
SO ₂	0.2
H ₂ S	0.006
NH ₃	0.05
Cl ₂	0.01

EMI

All electromagnetic interference (EMI) sources, from outside or inside of the switch and application system, adversely affect the switch in a conduction pattern of capacitance coupling, inductance coupling, electromagnetic wave radiation, or common impedance (including the grounding system) coupling. To prevent EMI, take the following actions:

- If AC power is used, use a single-phase three-wire power receptacle with protection earth (PE) to filter interference from the power grid.
- Keep the switch far away from radio transmitting stations, radar stations, and high-frequency devices.
- Use electromagnetic shielding, for example, shielded interface cables, when necessary.
- Route interface cables only indoors to prevent signal ports from getting damaged by overvoltage or overcurrent caused by lightning strikes.

Laser safety

The HP 5120 EI and 5120 SI switches are Class 1 laser devices.

⚠ WARNING!

Do not stare into any fiber port when the switch has power. The laser light emitted from the optical fiber may hurt your eyes.

Installation tools

- Flathead screwdriver
- Phillips screwdriver
- Needle-nose pliers
- Wire-stripping pliers
- Diagonal pliers
- ESD-preventive wrist strap
- Blow dryer

All these installation tools are user supplied.

Installing the switch

CAUTION:

Keep the tamper-proof seal on a mounting screw on the chassis cover intact, and if you want to open the chassis, contact your local HP agent for permission. Otherwise, HP shall not be liable for any consequence caused thereby.

Figure 29 Hardware installation flow

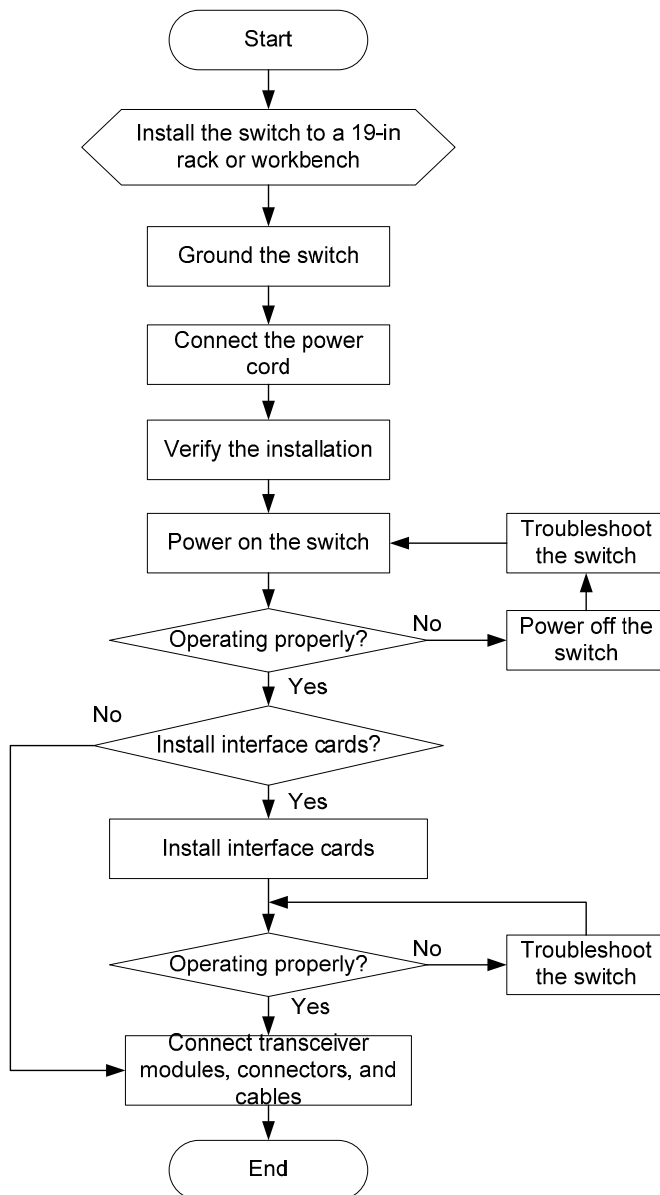

Installing a 5120 EI switch in a 19-inch rack

You can install a 5120 EI switch in a 19-inch standard rack by using different mounting positions. [Table 6](#) shows the installation methods available for the switches of different depths.

Table 6 Installation methods

Chassis	Depth	Use front mounting brackets only	Use front mounting brackets and a rack shelf	Use front and rear mounting brackets
5120-24G EI (2 slots)	300 mm (11.81 in)	Yes (see "Rack-mounting by using only front mounting brackets")	Yes (see "Rack-mounting by using front mounting brackets and a rack shelf")	No
5120-24G EI TAA (2 slots)				
5120-48G EI (2 slots)				
5120-48G EI TAA (2 slots)				
5120-24G EI				
5120-48G EI				
5120-24G-PoE+ EI (2 slots)	420 mm (16.54 in)	No	Yes (see "Rack-mounting by using front mounting brackets and a rack shelf")	Yes (see "Rack-mounting by using front and rear mounting brackets")
5120-24G-PoE+ EI TAA (2 slots)				
5120-48G-PoE+ EI (2 slots)				
5120-48G-PoE+ EI TAA (2 slots)				

NOTE:

For a switch with a 420 mm (16.54 in) of depth, the front mounting brackets are not weight-bearing.

Mounting brackets

Figure 30 Front mounting bracket

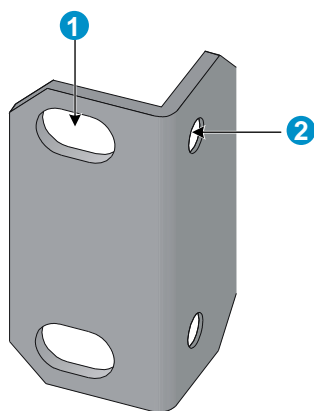

(1) Hole for attaching to a rack (by using an M6 screw)

(2) Hole for attaching to the switch chassis

Figure 31 Rear mounting bracket

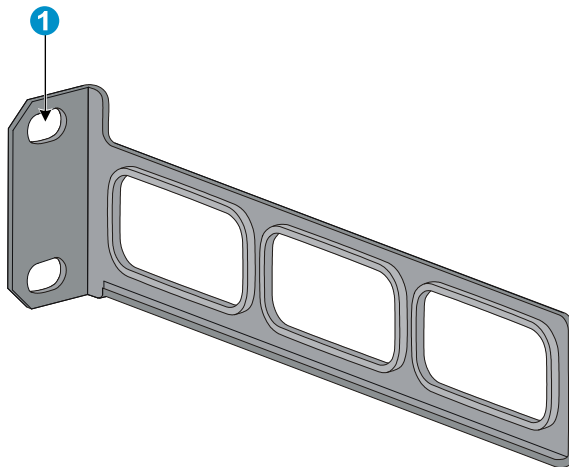

(1) Hole for attaching to a rack (by using an M6 screw)

NOTE:

The M6 screws for fixing the brackets to a rack are user supplied.

Table 7 shows the mounting bracket shipment for different switch models.

Table 7 Mounting bracket kit shipped with the 5120 EI switches

Chassis	Front mounting brackets	Rear mounting brackets
5120-24G EI (2 slots)		
5120-24G EI TAA (2 slots)		
5120-48G EI (2 slots)	One pair	N/A
5120-48G EI TAA (2 slots)		
5120-24G EI		
5120-48G EI		
5120-24G-PoE+ EI (2 slots)		
5120-24G-PoE+ EI TAA (2 slots)	One pair	One pair
5120-48G-PoE+ EI (2 slots)		
5120-48G-PoE+ EI TAA (2 slots)		

Rack-mounting by using only front mounting brackets

This installation method is available only for the 5120-24G EI (2 slots), 5120-24G EI TAA (2 slots), 5120-48G EI (2 slots), 5120-48G EI TAA (2 slots), 5120-24G EI, and 5120-48G EI switches.

This task requires two persons.

To mount a switch in a 19-inch standard rack by using only the front mounting brackets:

1. Wear an ESD-preventive wrist strap and make sure it makes good skin contact and is well grounded.
2. Check that the rack is well grounded and can support the weight of the switch chassis and all its accessories.

3. Unpack the front mounting brackets and the screws for fixing the brackets to the switch chassis.
4. Align the round holes in one bracket with the holes in the front mounting position of the switch chassis, and use the screws to fix the mounting bracket to the chassis, as shown in [Figure 32](#).
5. Repeat the previous step to attach the other mounting bracket to the chassis.

Figure 32 Attach the front mounting brackets to the chassis

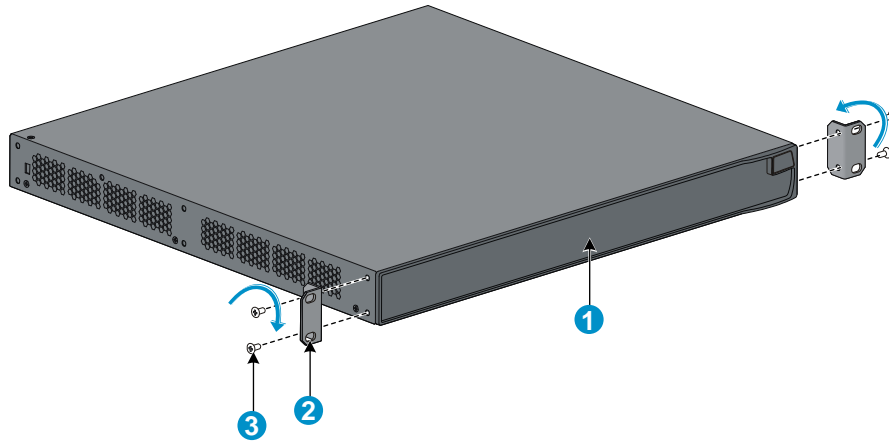

(1) Front panel of the switch

(2) Front mounting bracket

(3) Screw

6. Install cage nuts (user-supplied) in the mounting holes in the rack posts.
7. One person holds the switch chassis and aligns the oval holes in the brackets with the mounting holes in the rack posts, and the other person fixes the mounting brackets with M6 screws (user-supplied) to the rack, as shown in [Figure 33](#).

Figure 33 Attach the front mounting brackets to the rack

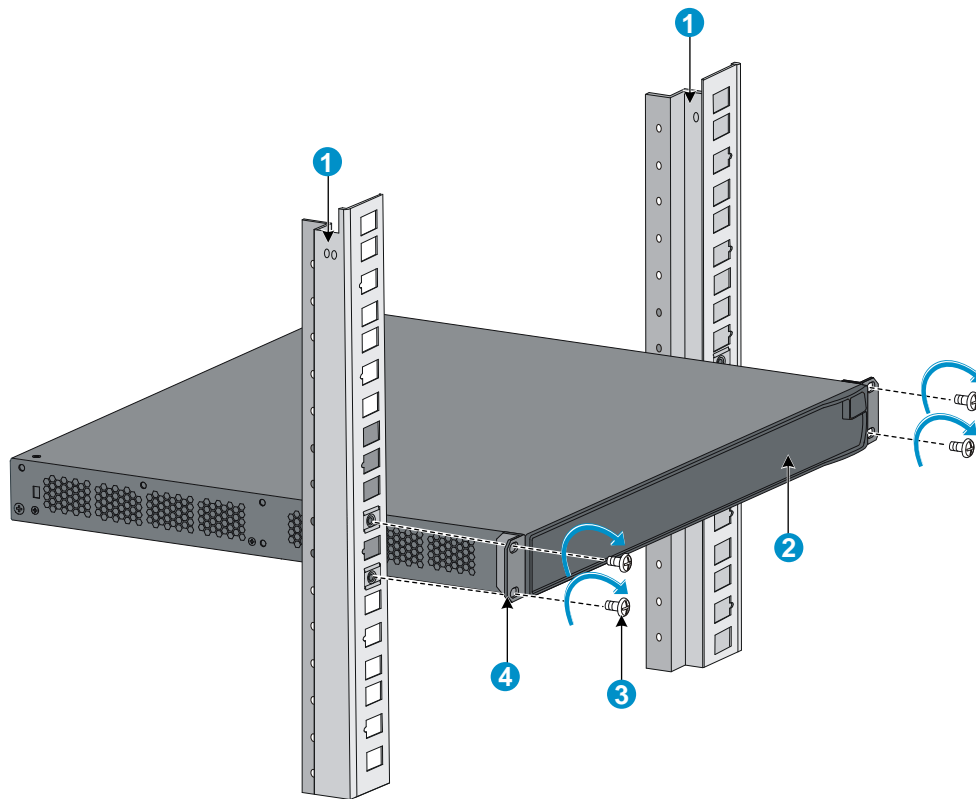

(1) Front square-holed post

(2) Front panel

(3) Screw for fixing the bracket to the square-holed post

(4) Front mounting bracket

Rack-mounting by using front mounting brackets and a rack shelf

This installation method is available for all 5120 EI switches.

To mount a switch in a 19-inch rack by using the front mounting brackets and a rack shelf:

1. Wear an ESD-preventive wrist strap and make sure it makes good skin contact and is well grounded.
2. Check that the rack is well grounded and can support the weight of the switch chassis and all its accessories.
3. Fix the rack shelf horizontally in a proper position in the rack.
4. Unpack the front mounting brackets and the screws for fixing the brackets to the switch chassis.
5. Align the round holes in one bracket with the holes in the front mounting position of the switch chassis, and use the removed screws to fix the mounting bracket to the chassis, as shown in [Figure 32](#).
6. Repeat the previous step to attach the other mounting bracket to the chassis.
7. Install cage nuts (user-supplied) in the mounting holes in the rack posts.
8. Place the switch on the rack shelf, push it into the rack until the brackets touch the rack posts, and fix the mounting brackets with M6 screws (user-supplied) to the rack, as shown in [Figure 33](#).

Rack-mounting by using front and rear mounting brackets

This installation method is available only for the 5120-24G-PoE+ EI (2 slots), 5120-24G-PoE+ EI TAA (2 slots), 5120-48G-PoE+ EI (2 slots), and 5120-48G-PoE+ EI TAA (2 slots) switches.

This task requires two persons. To install the switch in a 19-inch rack by using the front and rear mounting brackets:

1. Wear an ESD-preventive wrist strap and make sure it makes good skin contact and is well grounded.
2. Unpack the front mounting brackets and the screws for fixing the brackets to the switch chassis.
3. Align the round holes in one front mounting bracket with the holes in the front mounting position of the switch chassis, and use the removed screws to fix the mounting bracket to the chassis, as shown in [Figure 32](#).
4. Repeat the previous step to attach the other front mounting bracket to the chassis.
5. Unpack the rear mounting brackets and the load-bearing screws.
6. Fix the load-bearing screws in one of the rear mounting positions (see callout 2 in [Figure 34](#)) as needed.

Figure 34 Attach the front mounting brackets and load-bearing screws to the chassis

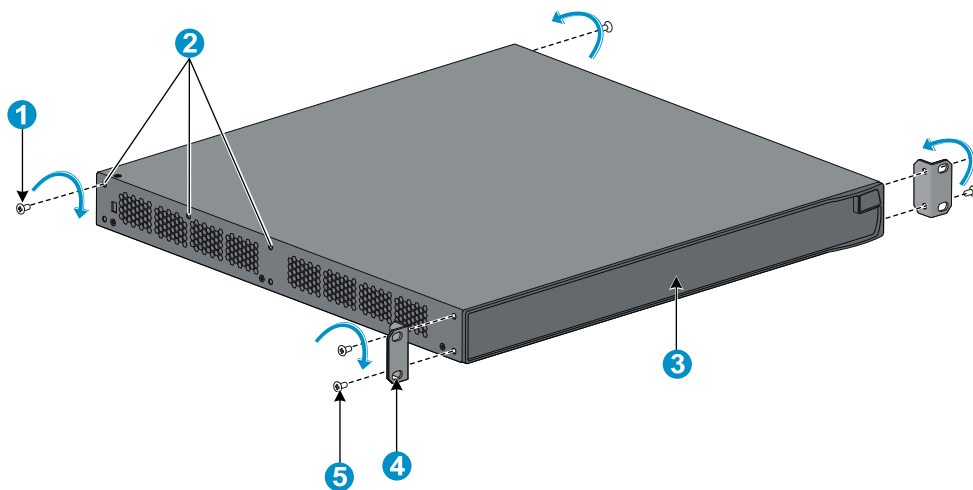

(1) Load-bearing screw

(2) Rear mounting positions

(3) Front panel

(4) Front mounting bracket

(5) Screw for fixing the front mounting bracket to the switch

NOTE:

The rear mounting brackets must closely contact with the load-bearing screws to support the chassis weight.

7. Install cage nuts (user-supplied) in the mounting holes in the front and rear rack posts.
8. Fix the rear mounting brackets to the rear posts with M6 screws (user supplied), as shown in [Figure 35](#).

Figure 35 Attach the rear mounting brackets to a rack

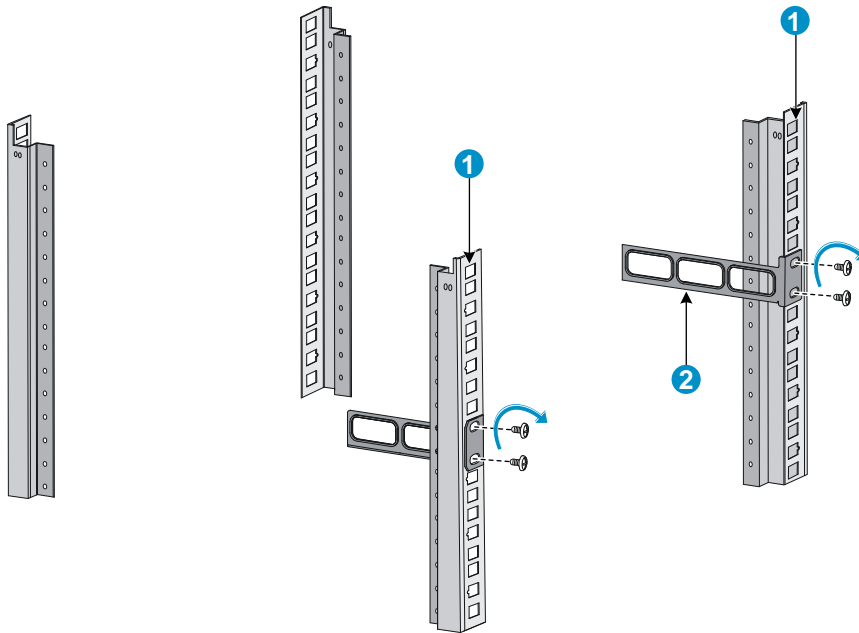

(1) Rear square-holed post

(2) Rear mounting bracket

9. One person supports the chassis bottom with one hand, holds the front part of the chassis with the other hand, and pushes the chassis into the rack gently.
Make sure that the load-bearing screws closely contact with the upper edges of the rear mounting brackets, as shown in [Figure 36](#).

Figure 36 Mount the switch in the rack

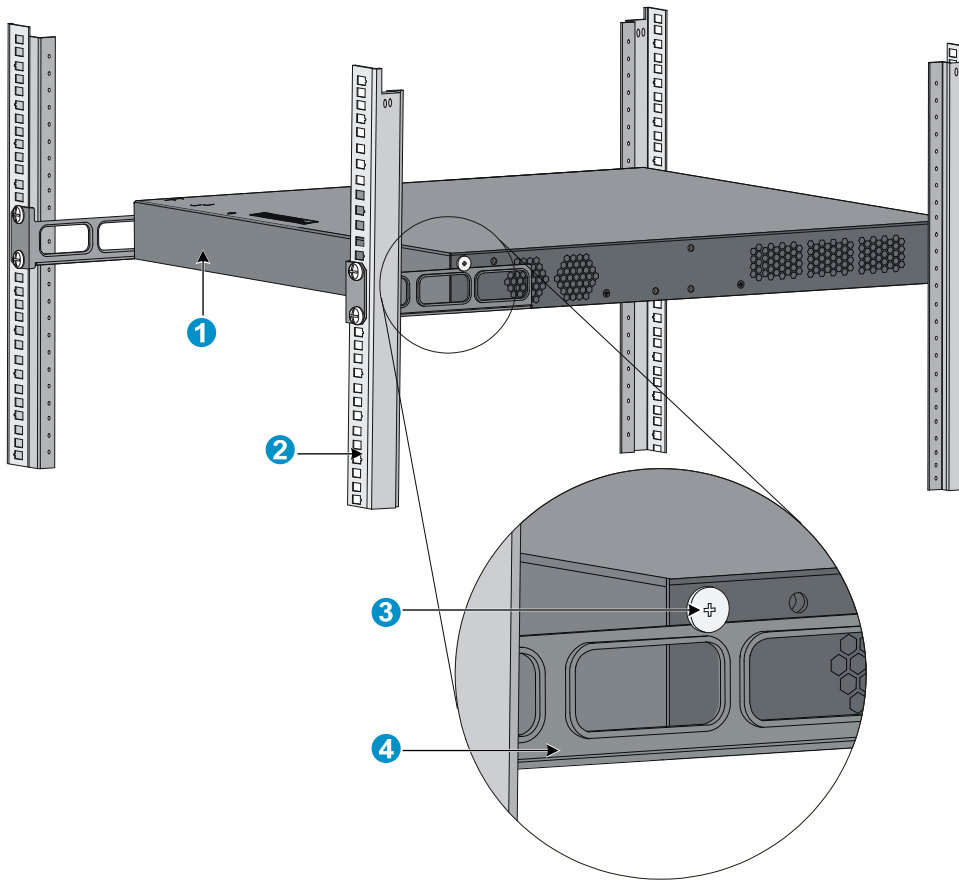

- | | |
|------------------------|----------------------------|
| (1) Rear panel | (2) Rear square-holed post |
| (3) Load-bearing screw | (4) Rear mounting bracket |

10. The other person aligns the oval holes in the front brackets with the mounting holes in the front rack posts, and fixes the front mounting brackets with M6 screws (user supplied) to the front rack posts, as shown in [Figure 37](#).

Make sure that front and rear mounting brackets have securely fixed the switch in the rack.

Figure 37 Attach the front brackets to the rack

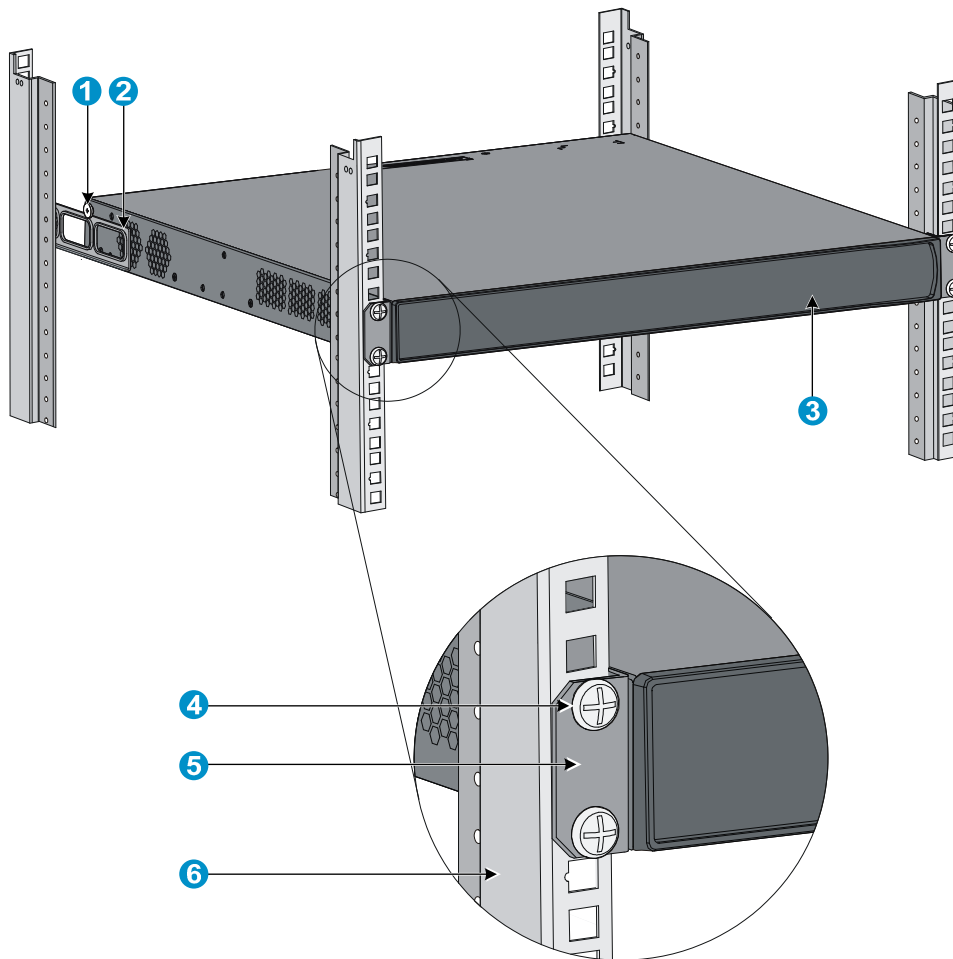

- | | |
|----------------------------|----------------------------------------------------------------|
| (1) Load-bearing screw | (2) Rear mounting bracket |
| (3) Front panel | (4) A screw used to fix the front mounting bracket to the rack |
| (5) Front mounting bracket | (6) Front square-holed post |

Installing a 5120 SI switch in a 19-inch rack

Figure 38 shows the general procedure for installing a 5120 SI switch in a 19-inch rack.

Figure 38 Install a 5120 SI switch in a 19-inch rack

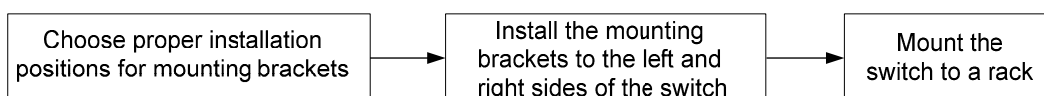

Mounting brackets and mounting positions

Table 8 Mounting brackets for the 5120 SI switches

Chassis	Bracket view	Mounting position
<ul style="list-style-type: none"> 5120-16G SI 5120-24G SI 	See callout A in Figure 39.	<ul style="list-style-type: none"> Front mounting (see Figure 40) Rear mounting (see Figure 41)
5120-8G SI	See callout B in Figure 39.	<ul style="list-style-type: none"> Front mounting (see Figure 42) Rear mounting (see Figure 43)
5120-8G-PoE+ SI	See callout D in Figure 39.	<ul style="list-style-type: none"> Front mounting (see Figure 44) Rear mounting (see Figure 45))
5120-8G-PPoE+ SI		
<ul style="list-style-type: none"> 5120-24G-PoE+ SI 5120-24G-PPoE+ SI 	See callout C in Figure 39.	<ul style="list-style-type: none"> Front mounting (see Figure 46) Mid-mounting (see Figure 47) Rear mounting (see Figure 48)
5120-48G SI		<ul style="list-style-type: none"> Front mounting (see Figure 46) Rear mounting (see Figure 48)

Figure 39 Mounting brackets

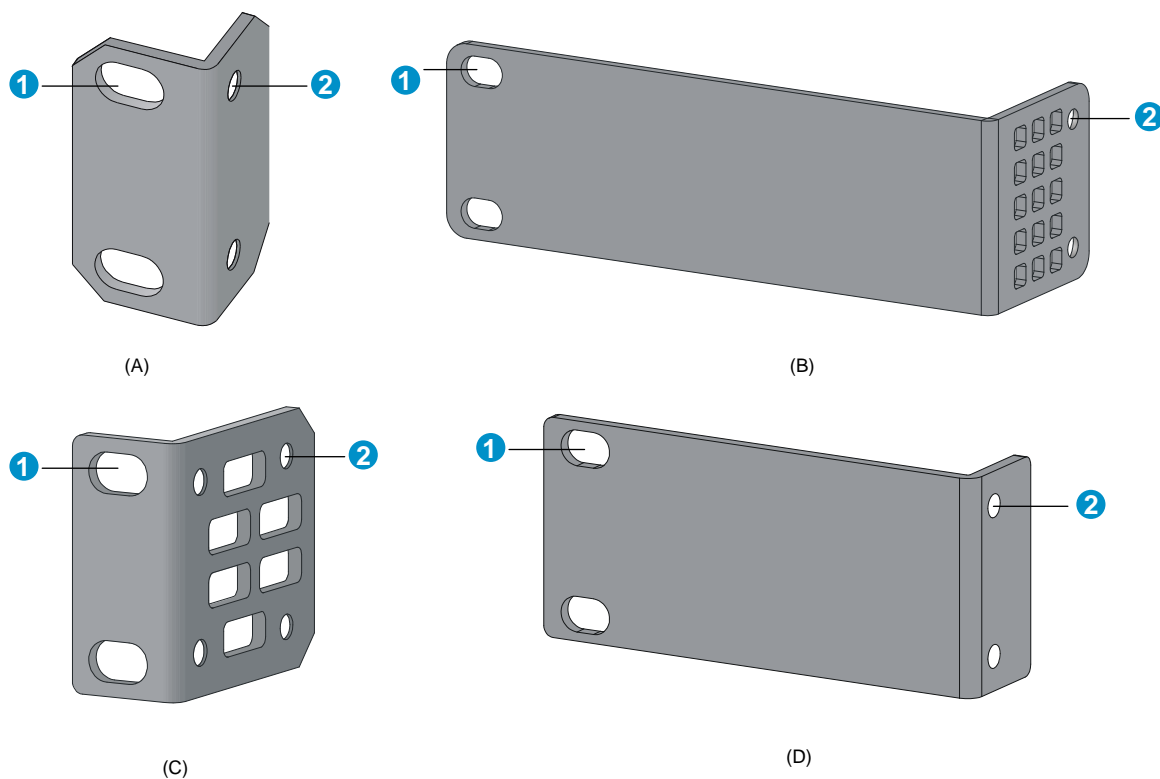

(1) Holes for attaching to a rack (by using M6 screws)

(2) Holes for attaching to the switch chassis

Attaching the mounting brackets to the switch chassis

To attach the mounting brackets to the switch chassis:

1. Identify the correct mounting position (see [Table 8](#)).
2. Align the round holes in one bracket with the holes in the mounting position.
3. Use screws to fix the mounting bracket to the chassis.
4. Repeat the preceding steps to attach the other mounting bracket to the chassis.

Figure 40 Front mounting position (5120-16G SI/5120-24G SI)

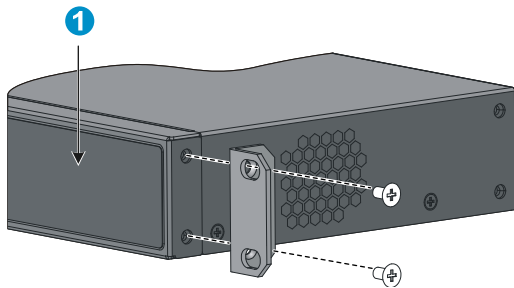

(1) Front panel

Figure 41 Rear mounting position (5120-16G SI/5120-24G SI)

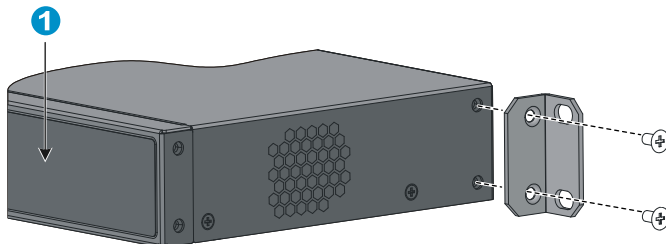

(1) Front panel

Figure 42 Front mounting position (5120-8G-SI)

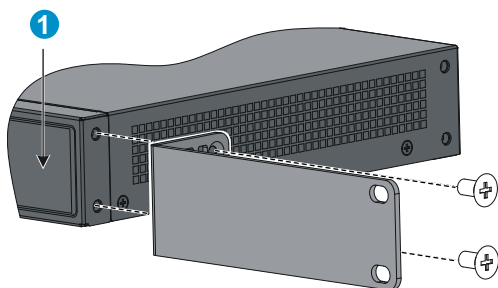

(1) Front panel

Figure 43 Rear mounting position (5120-8G-SI)

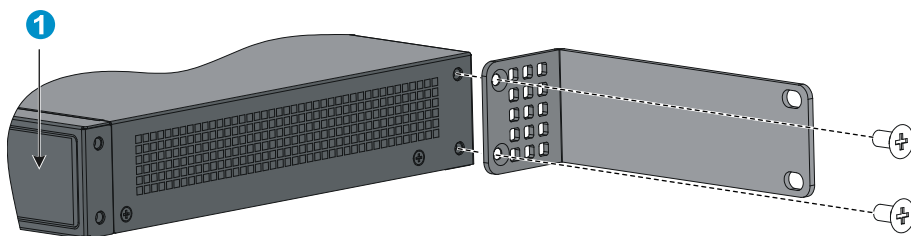

(1) Front panel

Figure 44 Front mounting position (5120-8G-PoE+ SI/5120-8G-PPoE+ SI)

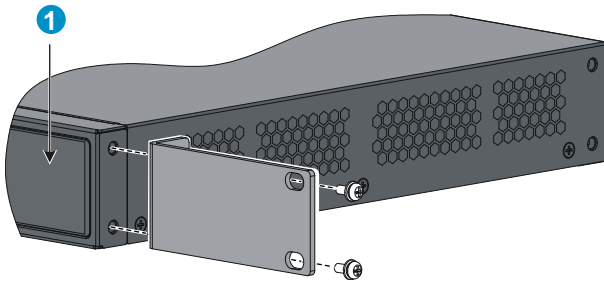

(1) Front panel

Figure 45 Rear mounting position (5120-8G-PoE+ SI/5120-8G-PPoE+ SI)

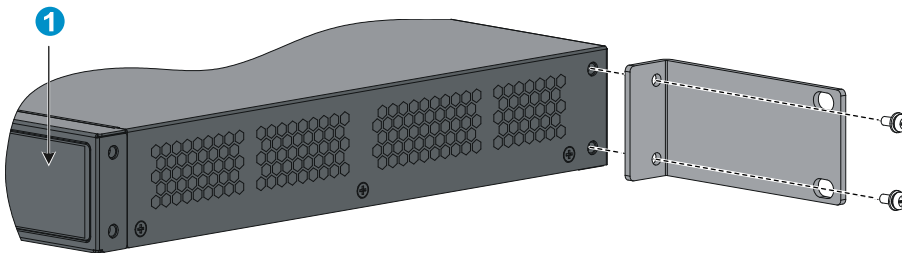

(1) Front panel

Figure 46 Front mounting position (5120-24G-PoE+ SI/5120-24G-PPoE+ SI/5120-48G SI)

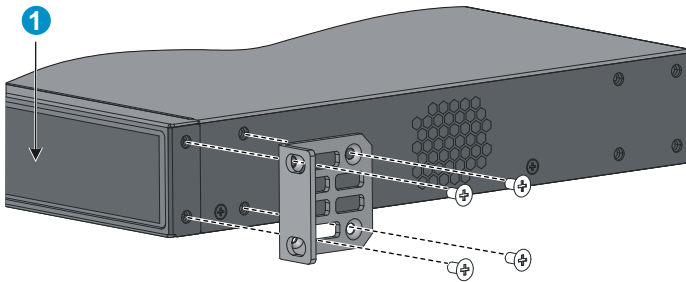

(1) Front panel

Figure 47 Mid-mounting position (5120-24G-PoE+ SI/5120-24G-PPoE+ SI)

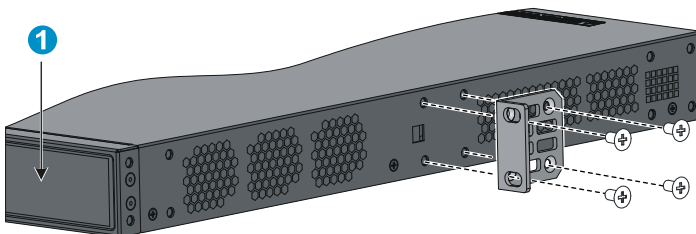

(1) Front panel

Figure 48 Rear mounting position (5120-24G-PoE+ SI/5120-24G-PPoE+ SI/5120-48G SI)

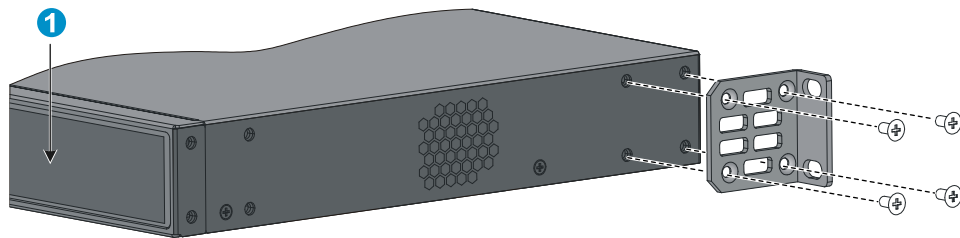

(1) Front panel

Rack-mounting the switch

This task requires two persons. To mount the switch in a rack:

1. Wear an ESD-preventive wrist strap and make sure it makes good skin contact and is well grounded.
2. Check that the rack is well grounded and can support the weight of the switch chassis and all its accessories.
3. Check that the mounting brackets have been securely attached to the switch chassis.
4. Install cage nuts (user-supplied) in the mounting holes in the rack posts.
5. One person holds the switch chassis and aligns the oval holes in the brackets with the mounting holes in the rack posts, and the other person fixes the mounting brackets with M6 screws (user-supplied) to the rack, as shown in [Figure 49](#) or [Figure 50](#).

NOTE:

If a rack shelf is available, you can put the switch on the rack shelf, slide the switch to an appropriate location, and fix the switch to the rack with the mounting brackets.

Figure 49 Mount the switch in a rack (5120-16G SI)

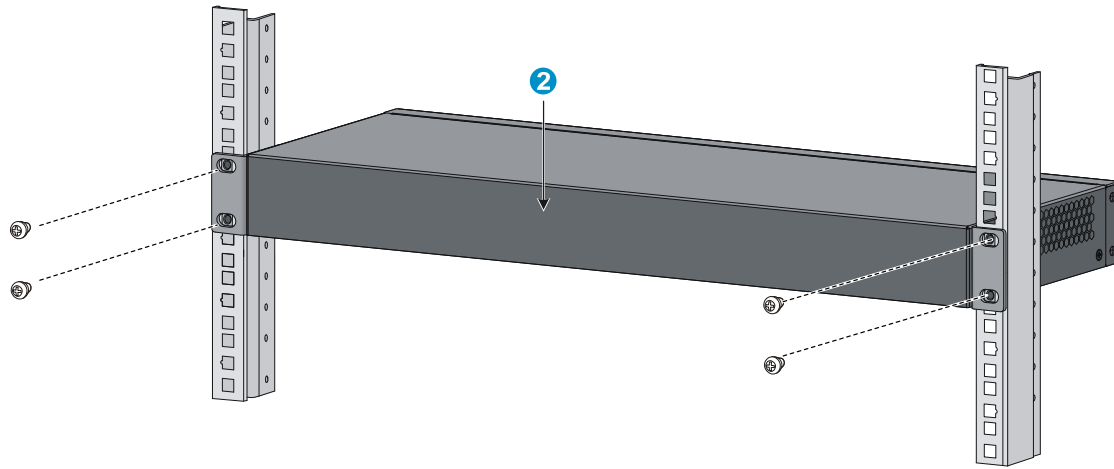
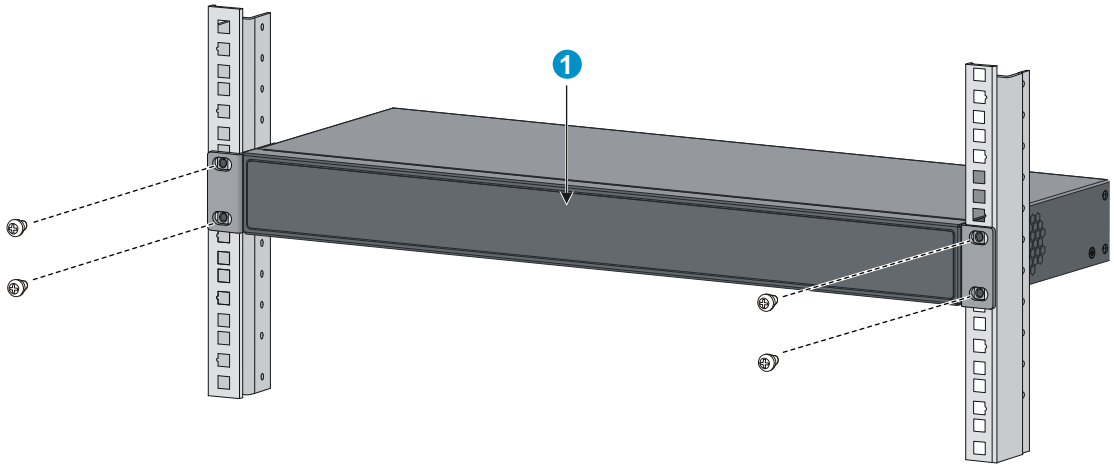

(1) Front panel

(2) Rear panel

Figure 50 Mount the switch in a rack (5120-24G-PoE+ SI/5120-24G-PPoE+ SI)

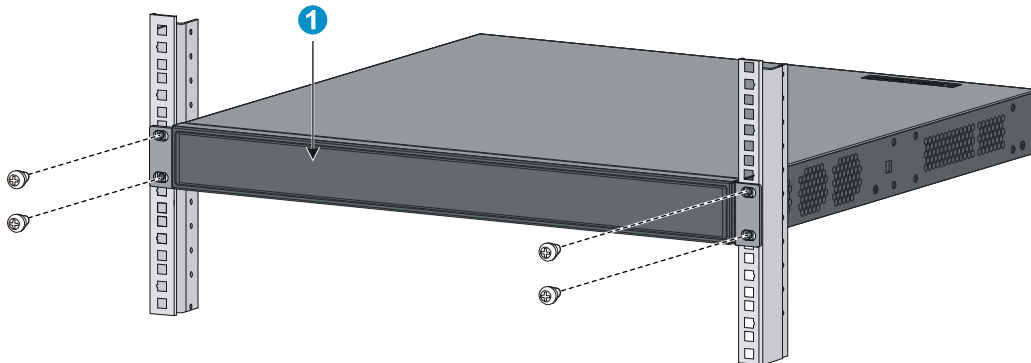

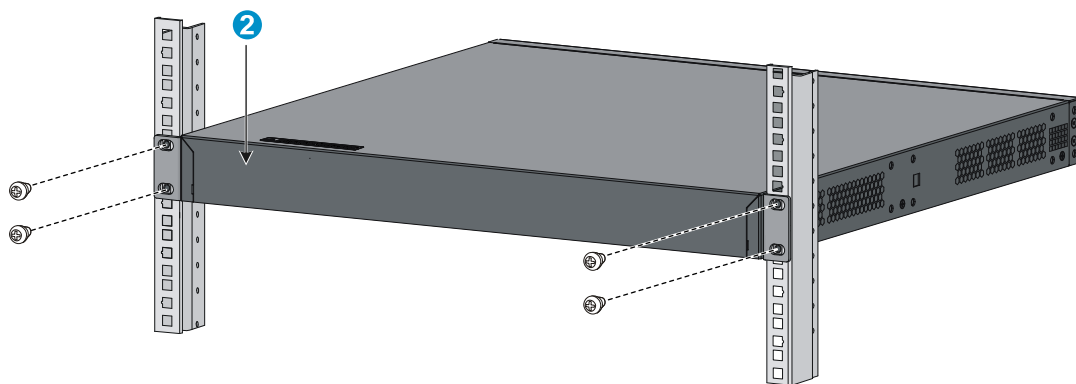
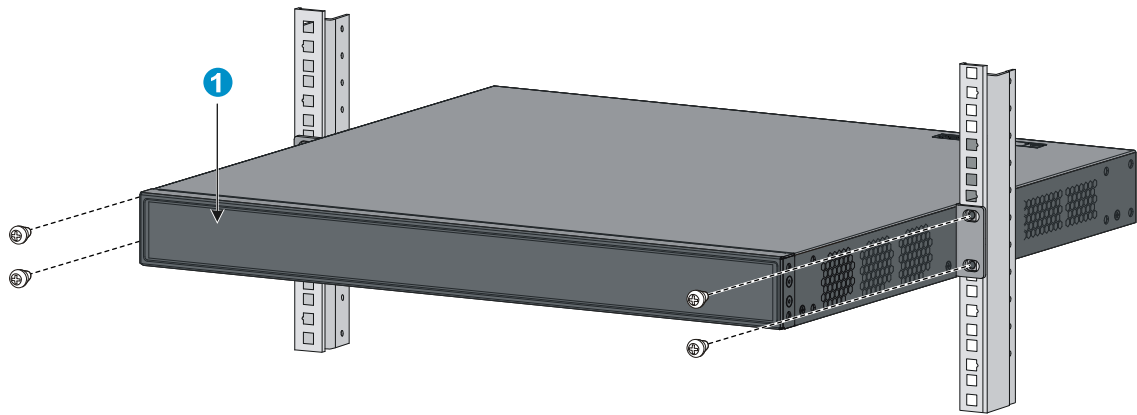

(1) Front panel

(2) Rear panel

Mounting the switch on a workbench

This installation method is available for all 5120 EI and 5120 SI switches.

To mount the switch on a workbench:

1. Check that the workbench is sturdy and well grounded.
2. Place the switch with bottom up, and clean the round holes in the chassis bottom with dry cloth.
3. Attach the rubber feet to the four round holes in the chassis bottom.
4. Place the switch with upside up on the workbench.

ⓘ IMPORTANT:

- Ensure good ventilation and 10 cm (3.9 in) of clearance around the chassis for heat dissipation.
- Avoid placing heavy objects on the switch.

Mounting the switch to a wall

You can mount the 5120-8G SI, 5120-8G-PoE+ SI, and 5120-8G-PPoE+ SI on concrete or wood walls.

Table 9 Models supporting wall mounting

Model	Hole distance
5120-8P SI	98.5 mm (3.88 in)
5120-8G-PoE+ SI	174.0 mm (6.85 in)
5120-8G-PPoE+ SI	174.0 mm (6.85 in)

Introduction to wall anchor kit

NOTE:

No wall anchor kit is provided with the 5120 SI Switch Series.

A wall anchor kit comprises an anchor and a screw, as shown in [Figure 51](#). The screw must have an outer diameter of no less than 4 mm (0.16 in) for wall mounting.

Figure 51 Wall anchor kit

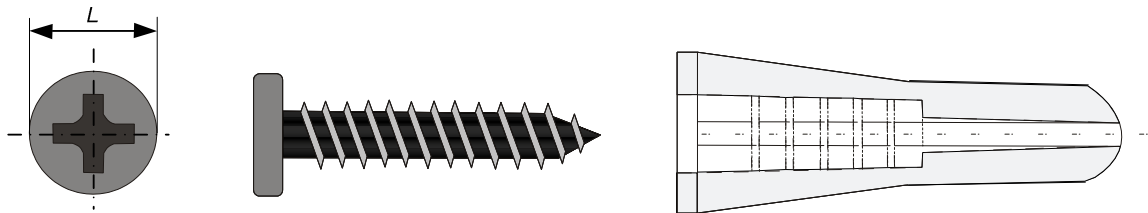

Installation procedure

To mount the switch to a wall:

1. Drill two holes at the same height and X mm apart at the locations you marked. See [Figure 52](#).

Figure 52 Hole distance

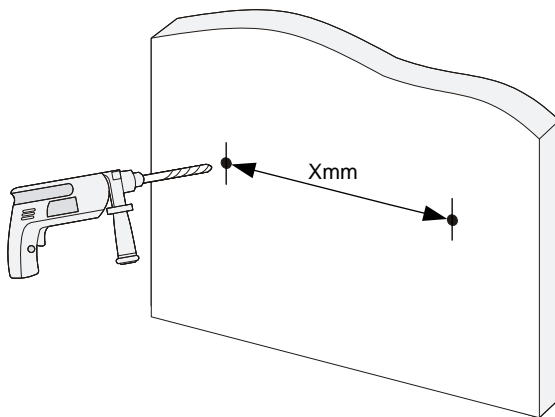

NOTE:

- The distance X between holes varies with devices. For specific distances, see [Table 9](#).
- Drill holes according to the sizes of the anchors and screws so that the anchors can go into the holes with only the edges remaining outside, and the screws can be tightly fixed on the wall.

2. Insert an anchor into each hole until the anchor is flush with the wall surface. See [Figure 53](#).
3. Drive a screw into each wall anchor, leaving a gap of at least 1.5 mm (0.06 in) between the base of the screw head and the wall anchor so that the switch can hang on the screws securely.

Figure 53 Install a wall anchor

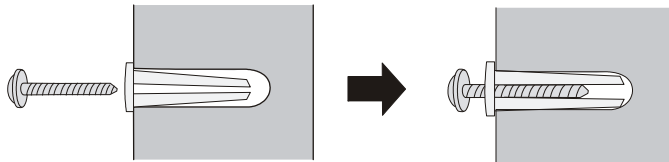

4. Align the two installation holes at the switch bottom with the two screws and hang the switch. See [Figure 54](#).

Figure 54 Wall mounting

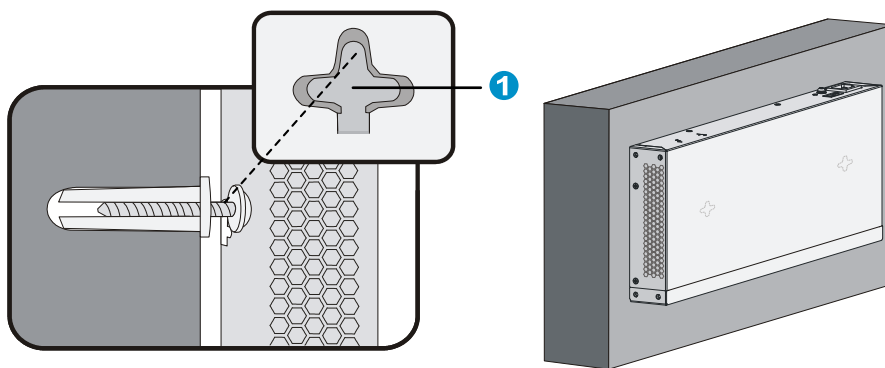

(1) Installation hole

△ CAUTION:

When you mount the switch, keep the Ethernet ports of the switch facing downwards and the two sides with ventilation holes vertical to the ground.

Mounting the switch through magnet mounting

The 5120-8G SI, 5120-8G-PoE+ SI, and 5120-8G-PPoE+ SI support magnet mounting.

Introduction to magnetic mounting kit

A magnetic mounting kit comprises one permanent magnet and one M3*6 countersunk head screw, as shown in [Figure 55](#). Four magnetic mounting kits are needed for each switch.

Figure 55 Magnet mounting kit

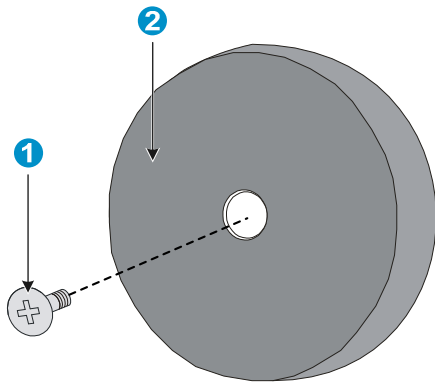

(1) M3*6 countersunk head screw

(2) Permanent magnet

Installation procedure

To complete magnet mounting:

1. Use a Phillips screwdriver to pass the countersunk head screw through the round hole at the center of the permanent magnet, fasten it to a blind nut in the dent of the switch bottom, and make sure that the permanent magnet and the switch are fastened reliably. See [Figure 56](#).

NOTE:

- Remove the cushion, if any, from the dent before installation.
 - To ensure the firmness of installation, be sure to use four permanent magnets to secure each switch.
2. Attach the magnet-mounted switch to the specified location. Do not get your fingers stuck between.

Figure 56 Magnet mounting

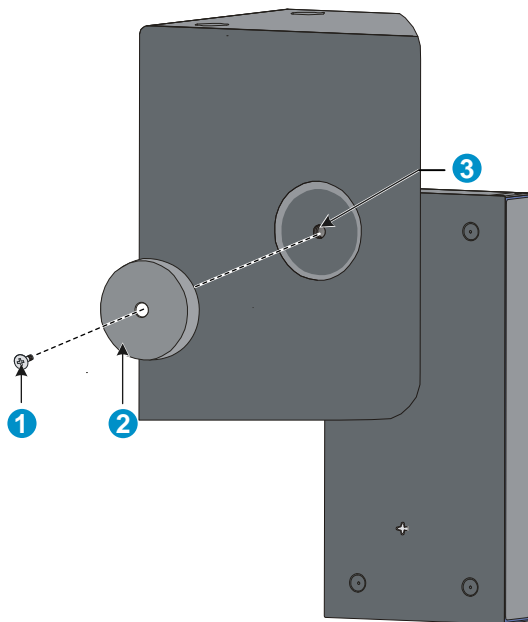

(1) M3*6 countersunk head screw

(2) Permanent magnet

(3) Blind nut in the dent of the switch bottom

⚠ CAUTION:

- Apply magnet mounting to only the 5120-8G SI, 5120-8G-PoE+ SI, and 5120-8G-PPoE+ SI. Otherwise, a falloff or mis-operation may occur.
 - Select the installation location carefully. In the case of poor surface, magnet mounting may not be reliable.
 - Put the switch at a stable place free from vibrations or shocks. Otherwise, personal injuries or equipment damage may occur.
 - Avoid installing the switch at a high place because bodily injuries or equipment damage may occur in case of a falloff.
 - Avoid frequently moving the desk-mounted switch because such movements may damage the surface coating.
 - To install the device vertically, keep the front panel of the switch facing downwards and the two sides with ventilation holes vertical to the ground.
 - Make sure that the weight of external cables does not bring about a falloff, which may result in bodily injuries or equipment damage.
 - Keep magnetic cards away from magnets to avoid erasure of any information.
 - Keep computers and monitors that are easily influenced by magnetic fields away from magnets. Otherwise, faults may occur to these electronic devices.
-

Grounding the switch

⚠ WARNING!

Correctly connecting the switch grounding cable is crucial to lightning protection and EMI protection.

NOTE:

The power and grounding terminals in this section are for illustration only.

The power input end of the switch has a noise filter, whose central ground is directly connected to the chassis to form the chassis ground (commonly known as PGND). You must securely connect this chassis ground to the earth so the faradism and leakage electricity can be safely released to the earth to minimize EMI susceptibility of the switch.

You can ground the switch in one of the following ways, depending on the grounding conditions available at the installation site:

- [Grounding the switch with a grounding strip](#)
- [Grounding the switch with a grounding conductor buried in the earth ground](#)
- [Grounding the switch by using the AC power cord](#)

Grounding the switch with a grounding strip

If a grounding strip is available at the installation site, connect the grounding cable to the grounding strip.

⚠ WARNING!

Connect the grounding cable to the grounding system in the equipment room. Do not connect it to a fire main or lightning rod.

NOTE:

The 5120 EI series, 5120-24G-PoE+ SI, and 5120-24G-PPoE+ SI switches come with an OT terminal for connecting to a grounding strip. For other switch models, you must prepare OT terminals yourself.

To connect the grounding cable, for example, to a 5120-48G EI (2 slots) switch:

1. Identify the grounding point (with a grounding sign) on the rear panel of the switch chassis, and remove the grounding screw from the grounding point.
2. Attach the grounding screw to the OT terminal of the grounding cable.
3. Use a screwdriver to fasten the grounding screw into the grounding screw hole.

Figure 57 Connect the grounding cable to the grounding hole of the switch chassis

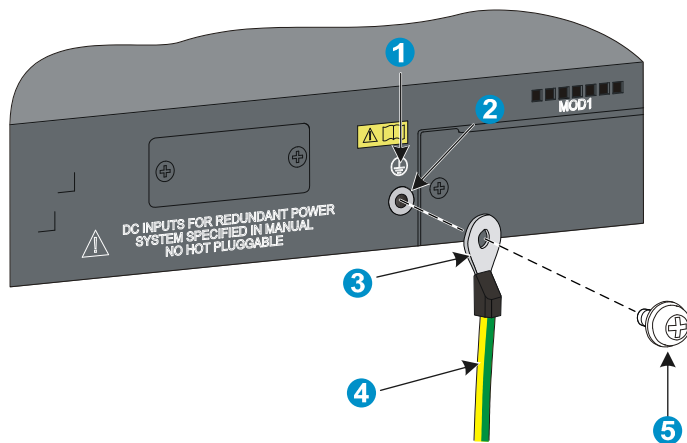

(1) Grounding sign

(2) Grounding hole

(3) OT terminal

(4) Grounding cable

(5) Grounding screw

4. Remove the hex nut of a grounding post on the grounding strip.
5. Cut the grounding cable as appropriate for connecting to the grounding strip.
6. Make the connector for connecting to the grounding strip:
 - If an OT terminal is available, peel 5 mm (0.20 in) of insulation sheath by using a wire stripper, and insert the bare metal part through the black insulation covering into the end of the OT terminal, secure the metal part of the cable to the OT terminal with a crimper, cover the joint with the insulation covering, and heat the insulation covering with a blow dryer to completely cover the metal part (see callout A in [Figure 58](#)).
 - If no OT terminal is available, peel the insulation sheath as appropriate by using a wire stripper, and bend the bare metal part into a ring (see callout B in [Figure 58](#)). Attach the OT terminal or the ring to the grounding strip through the grounding post, and fasten it with the removed hex nut, see [Figure 59](#).

Figure 58 Make a grounding cable connector

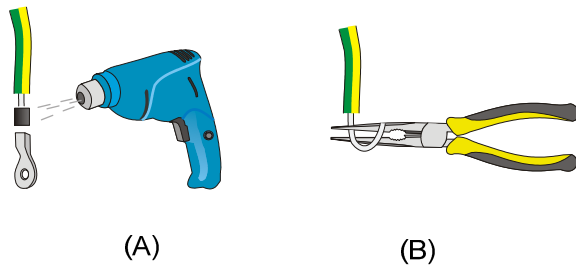
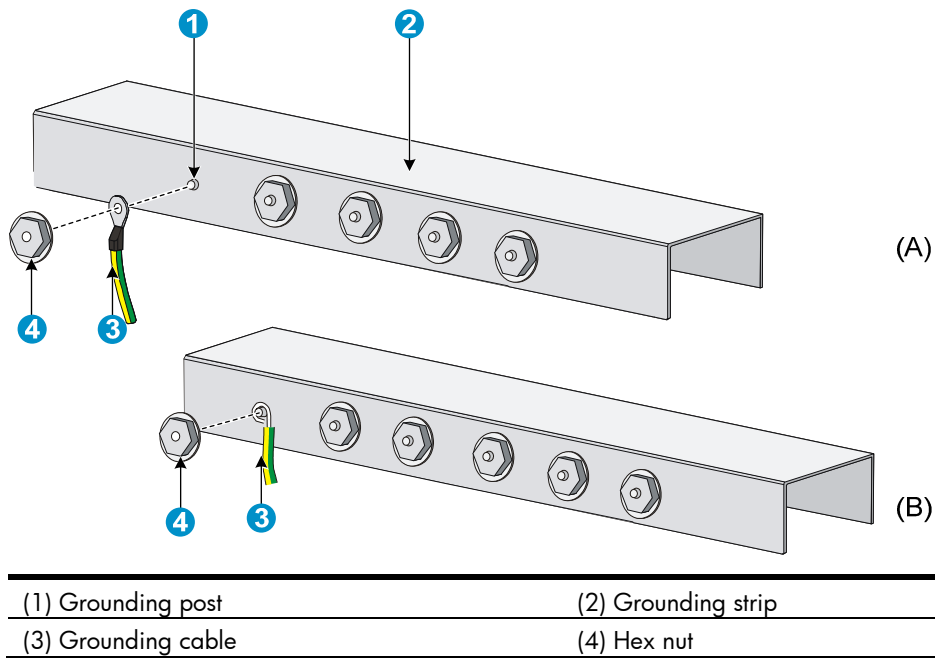

Figure 59 Connect the grounding cable to a grounding strip



Grounding the switch with a grounding conductor buried in the earth ground

If the installation site has no grounding strips, but earth ground is available, hammer a 0.5 m (1.64 ft) or longer angle iron or steel tube into the earth ground to serve as a grounding conductor.

The dimensions of the angle iron must be at least 50 × 50 × 5 mm (1.97 × 1.97 × 0.20 in). The steel tube must be zinc-coated and its wall thickness must be at least 3.5 mm (0.14 in).

Weld the yellow-green grounding cable to the angel iron or steel tube and treat the joint for corrosion protection.

Figure 60 Ground the switch by burying the grounding conductor into the earth ground

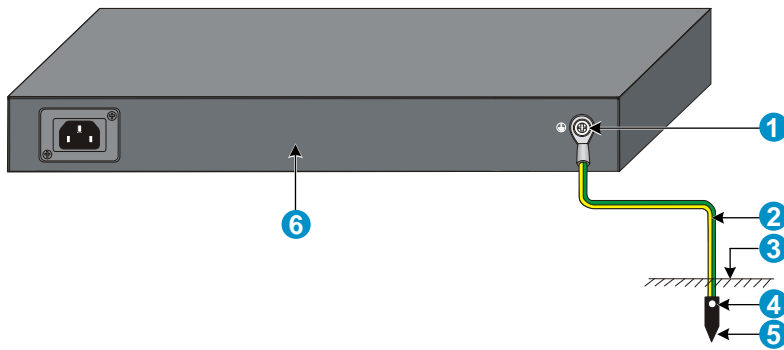

(1) Grounding screw	(2) Grounding cable	(3) Earth
(4) Joint	(5) Grounding conductor	(6) Chassis rear panel

Grounding the switch by using the AC power cord

If the installation site has no grounding strips or earth ground, you ground an AC-powered switch through the PE wire of the power cord, but must make sure:

- The power cord has a PE terminal.
- The ground contact in the power outlet is securely connected to the ground in the power distribution room or on the AC transformer side.
- The power cord is securely connected to the power outlet.

NOTE:

If the ground contact in the power outlet is not connected to the ground, report the problem and reconstruct the grounding system.

Figure 61 Ground through the PE wire of the AC power cord

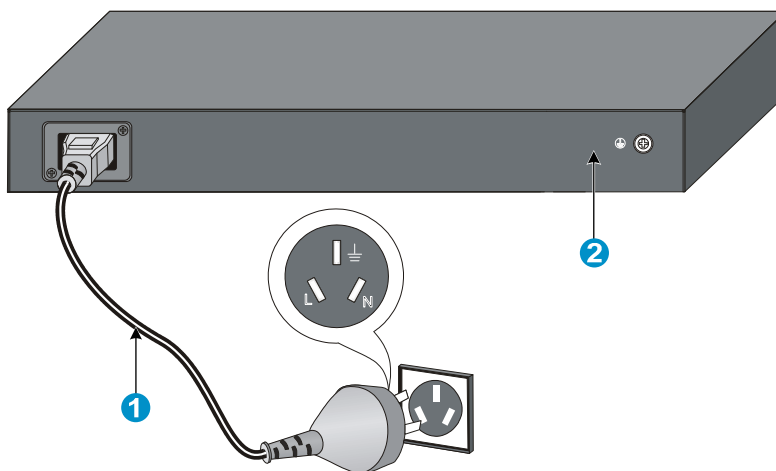

(1) Three-wire AC power cord	(2) Chassis rear panel
------------------------------	------------------------

NOTE:

To guarantee the grounding effect, use the grounding cable provided with the switch to connect to the grounding strip in the equipment room as long as possible.

Connecting the power cord

WARNING!

Make sure that the grounding cable has been properly connected before powering on the switch.

Use [Table 10](#) to identify the power cord connection procedures available for your switch.

Table 10 Power cord connection methods at a glance

Chassis	Connection procedure
5120-8G SI	Connecting the AC power cord
5120-16G SI	
5120-24G SI	
5120-48G SI	
5120-8G-PPoE+ SI	
5120-8G-PoE+ SI	
5120-24G-PPoE+ SI	
	AC-input: Connecting the AC power cord
5120-24G-PoE+ SI	RPS input: Connecting the switch to a -52 to -55 VDC output RPS
5120-24G EI (2 slots)	Connecting the AC power cord
5120-24G EI TAA (2 slots)	
5120-48G EI (2 slots)	
5120-48G EI TAA (2 slots)	
5120-24G EI	
5120-48G EI	Connecting the switch to a +12 VDC output RPS
5120-24G-PoE+ EI (2 slots)	AC-input: Connecting the AC power cord
5120-24G-PoE+ EI TAA (2 slots)	RPS input: Connecting the switch to a -52 to -55 VDC output RPS
5120-48G-PoE+ EI (2 slots)	
5120-48G-PoE+ EI TAA (2 slots)	

Connecting the AC power cord

To connect the AC power cord:

1. Wear an ESD-preventive wrist strap and make sure it makes good skin contact and is well grounded.
2. Connect one end of the AC power cord to the AC-input power receptacle on the switch.
[Figure 62](#) uses a 5120-48G EI switch for illustration, and [Figure 63](#) uses a 5120-24G SI switch for illustration.
3. Connect the other end of the AC power cord to the AC power outlet.

Figure 62 Connect the AC power cord to the 5120-48G EI switch

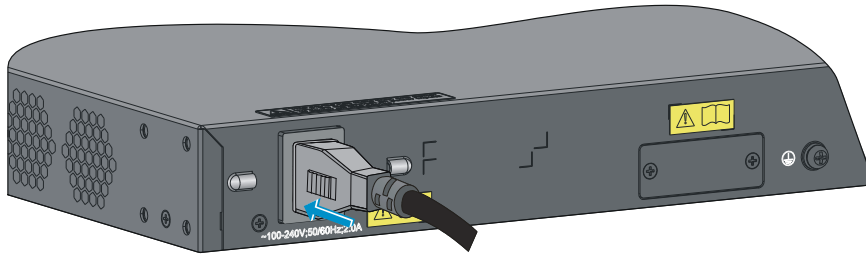
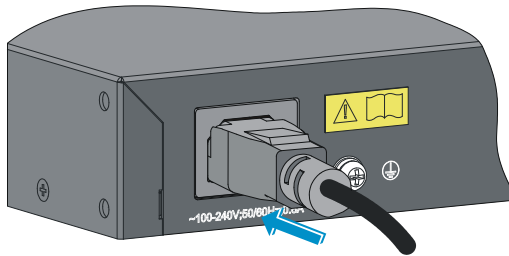

Figure 63 Connect the AC power cord to the 5120-24G SI switch



Connecting the switch to a +12 VDC output RPS

This section applies to the 5120-24G EI (2 slots), 5120-24G EI TAA (2 slots), 5120-48G EI (2 slots), 5120-48G EI TAA (2 slots), 5120-24G EI, and 5120-48G EI switches.

To connect these switches to the RPS that provides +12 VDC output:

1. Wear an ESD-preventive wrist strap and make sure it makes good skin contact and is well grounded.
2. Loosen the captive screws on the RPS receptacle protective cover and remove the protective cover, see [Figure 64](#).

If you do not use the RPS receptacle, install the protective cover.

Figure 64 Remove the RPS receptacle protective cover

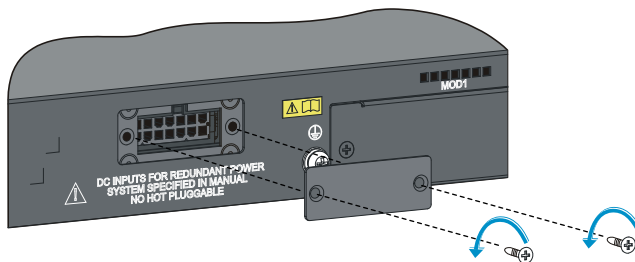

3. Unpack the RPS cable shipped with the RPS, identify the plug for connecting to the switch, correctly orient the plug with the RPS receptacle on the switch chassis, and insert the plug into the receptacle (see callout 1 in [Figure 65](#)).

The RPS receptacle is foolproof. If you cannot insert the plug into the receptacle, re-orient the plug rather than use excessive force to push it in.

4. Tighten the screws on the plug with a flat-blade screwdriver to secure the plug in the RPS receptacle (see callout 2 in [Figure 65](#)).

5. Connect the other end of the power cord to the RPS.

Figure 65 Connect the RPS cable to the +12 VDC RPS receptacle

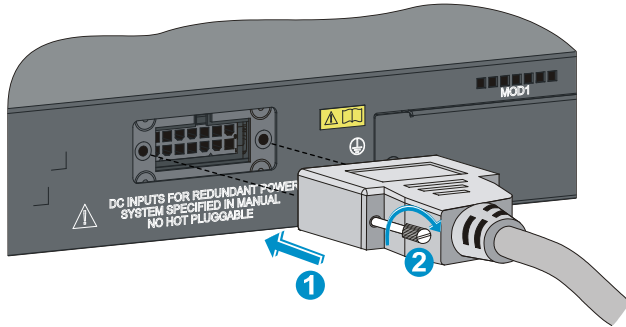

Connecting the switch to a -52 to -55 VDC output RPS

This section applies to the 5120-24G-PoE+ EI (2 slots), 5120-24G-PoE+ EI TAA (2 slots), 5120-48G-PoE+ EI (2 slots), 5120-48G-PoE+ EI TAA (2 slots) and 5120-24G-PoE+ SI switches.

To connect these switches to the RPS that provides -52 to -55 VDC output:

1. Wear an ESD-preventive wrist strap and make sure it makes good skin contact and is well grounded.
2. Unpack the RPS cable shipped with the RPS, identify the plug for connecting to the switch, correctly orient the plug with the RPS receptacle on the switch chassis, and insert the plug into the receptacle (see callout 1 in Figure 66).
The RPS receptacle is foolproof. If you cannot insert the plug into the receptacle, re-orient the plug rather than use excessive force to push it in.
3. Tighten the screws on the plug with a flat-blade screwdriver to secure the plug in the RPS receptacle (see callout 2 in Figure 66).
4. Connect the other end of the power cord to the RPS.
5. Make sure that the RPS is supplying power and verify that the RPS status LED is ON.

Figure 66 Connect the RPS cable to the -52 to -55 VDC RPS receptacle

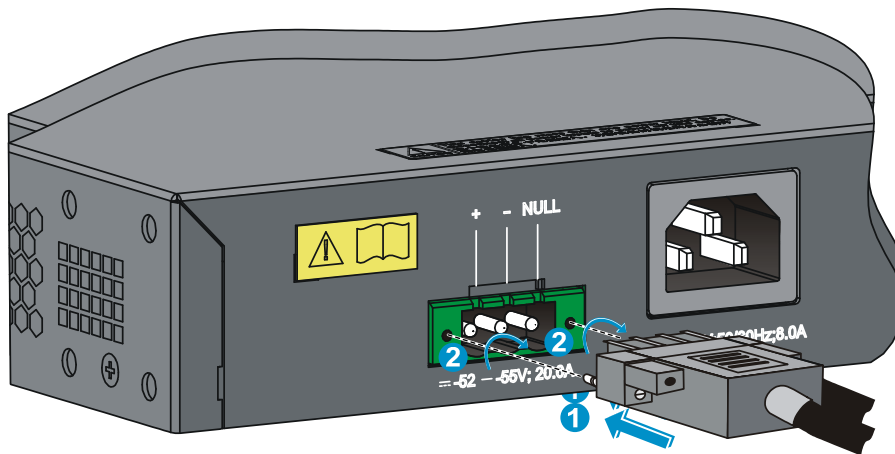

Installing/removing an interface card (only for the 5120 EI switches)

This section applies to all 5120 EI switches but the 5120-24G EI and 5120-48G EI. For the interface cards available for the switches, see [“Interface cards \(only for the 5120 EI switches\).”](#)

This section uses the LSPM2SP2P interface card as an example to describe the procedures of installing and removing an interface card.

ⓘ IMPORTANT:

To set up a 5120 EI IRF fabric, you must install interface cards. To choose a correct slot for an interface card, see [“Planning the cabling scheme for a 5120 EI IRF fabric.”](#)

Installing an interface card

To install an interface card in an interface card slot at the rear of the chassis:

1. Wear an ESD-preventive wrist strap and make sure it makes good skin contact and is well grounded.
2. Loosen the mounting screws on the filler panel over the interface card slot with a Phillips screwdriver and remove the filler panel.

Figure 67 Remove the filler panel over an interface card slot

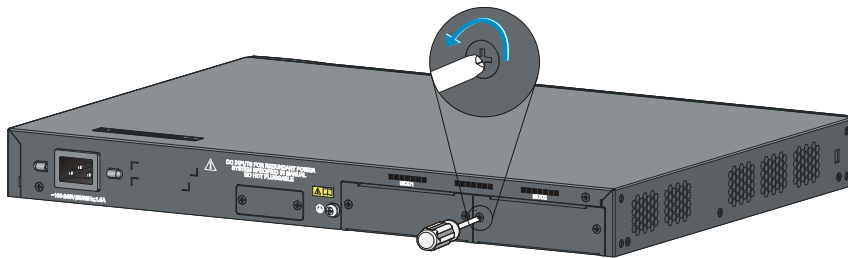

3. Hold the captive screws on the front panel of the interface card, and gently push the interface card in along the slot guide rail until the interface card is in close contact with the switch chassis (see callout 1 in [Figure 68](#)).
4. Tighten the captive screws with a Phillips screwdriver to fix the interface card in the slot (see callout 2 in [Figure 68](#)).

Figure 68 Install an interface card (II)

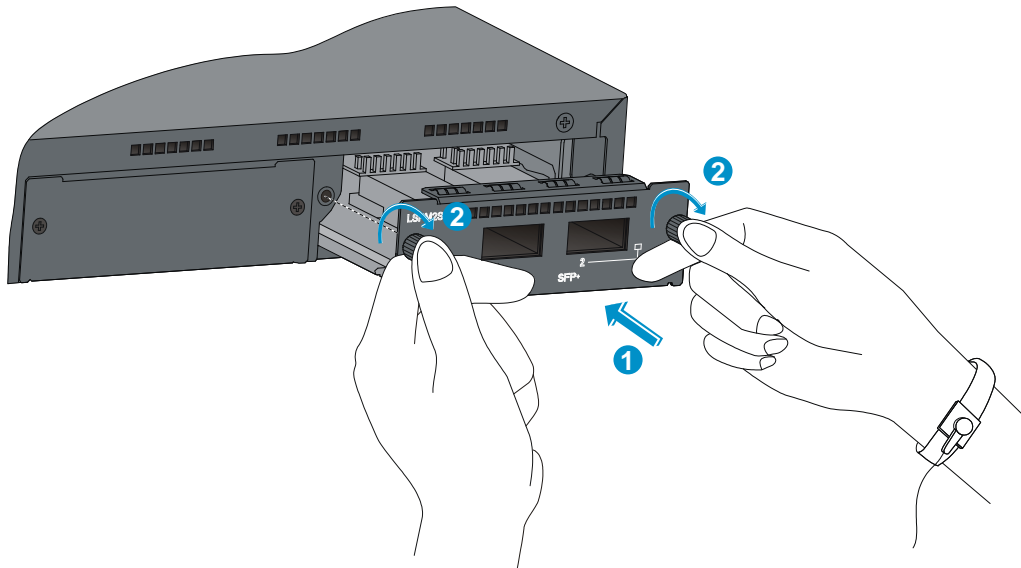

NOTE:

- Put away the removed filler panel for future use.
- When you tighten the captive screws, the torque must not be higher than 0.4 N-m.

Removing an interface card

To remove an interface card:

1. Wear an ESD-preventive wrist strap and make sure it makes good skin contact and is well grounded.
2. Use a Phillips screwdriver to completely loosen the captive screws at both sides of the interface card.
3. Pull the interface card along the guide rails until it completely comes out of the switch chassis.

CAUTION:

- Do not touch the surface-mounted components directly with your hands.
- Do not use too much force during the operation.
- If no new card is to be installed, install the filler panel to prevent dust and ensure good ventilation in the switch.

Installing/removing a dedicated CX4/SFP+ cable

The dedicated CX4 and SFP+ cables for the 5120 EI switches are hot swappable.

Installing a dedicated CX4/SFP+ cable

CAUTION:

The cable bending radius must be at least eight times the cable diameter.

To connect a CX4 or SFP+ cable to a port on a CX4/SFP+ interface card:

1. Wear an ESD-preventive wrist strap and make sure it makes good skin contact is well grounded.
2. Correctly orient one connector of the cable with the port and insert the cable connector into the port.

Removing a dedicated CX4/SFP+ cable

To remove a CX4 or SFP+ cable from a port on a CX4/SFP+ interface card:

1. Wear an ESD-preventive wrist strap and make sure it makes good skin contact and is well grounded.
2. Hold the cable connector and pull the pull latch of the connector to remove the cable from the switch.

Verifying the installation

After you complete the installation, verify that:

- There is enough space for heat dissipation around the switch, and the rack or workbench is stable.
- The grounding cable is securely connected.
- The correct power source is used.
- The power cords are properly connected.
- All the interface cables are cabled indoors. If any cable is routed outdoors, verify that the socket strip with lightning protection and lightning arresters for network ports have been properly connected.

Accessing the switch for the first time

Setting up the configuration environment

The first time you access the switch you must use a console cable to connect a console terminal, for example, a PC, to the console port on the switch.

Figure 69 Connect the console port to a terminal

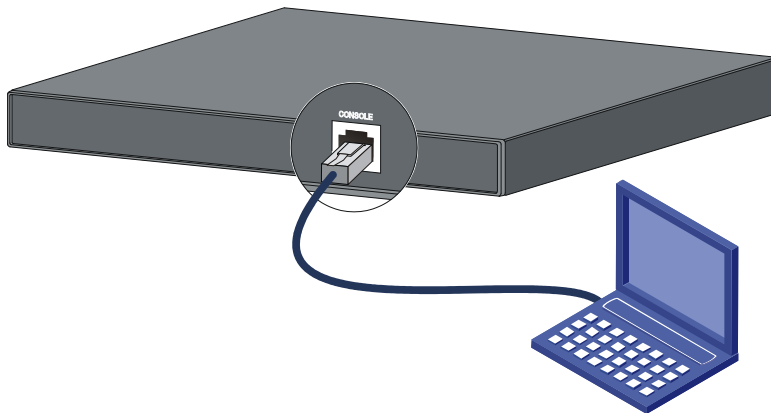

Connecting the console cable

Console cable

A console cable is an 8-core shielded cable, with a crimped RJ-45 connector at one end for connecting to the console port of the switch, and a DB-9 female connector at the other end for connecting to the serial port on the console terminal.

Figure 70 Console cable

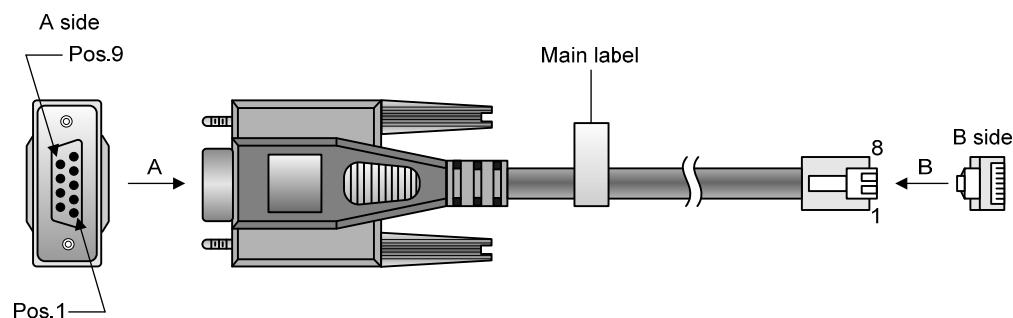

Connection procedure

To connect a terminal, for example, a PC, to the switch:

1. Plug the DB-9 female connector of the console cable to the serial port of the PC.

2. Connect the RJ-45 connector to the console port of the switch.

NOTE:

- Identify the mark on the console port and make sure that you are connecting to the correct port.
- The serial ports on PCs do not support hot swapping. If the switch has been powered on, connect the console cable to the PC before connecting to the switch, and when you disconnect the cable, first disconnect from the switch.

Setting terminal parameters

To configure and manage the switch, you must run a terminal emulator program on the console terminal.

The following are the required terminal settings:

- Bits per second—9,600
- Data bits—8
- Parity—None
- Stop bits—1
- Flow control—None
- Emulation—VT100

To set terminal parameters, for example, on a Windows XP HyperTerminal:

1. Select **Start > All Programs > Accessories > Communications > HyperTerminal**.
The **Connection Description** dialog box appears.
2. Enter the name of the new connection in the **Name** field and click **OK**.

Figure 71 Connection description

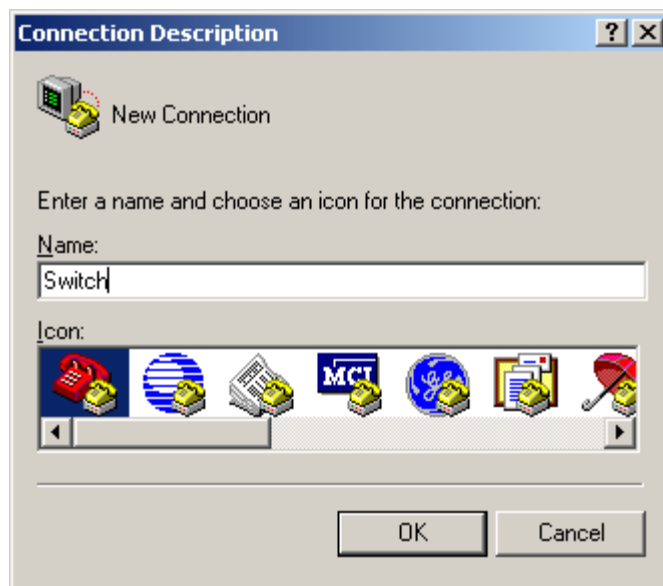

3. Select the serial port to be used from the **Connect using** list, and click **OK**.

Figure 72 Set the serial port used by the HyperTerminal connection



4. Set **Bits per second** to **9600**, **Data bits** to **8**, **Parity** to **None**, **Stop bits** to **1**, and **Flow control** to **None**, and click **OK**.

Figure 73 Set the serial port parameters

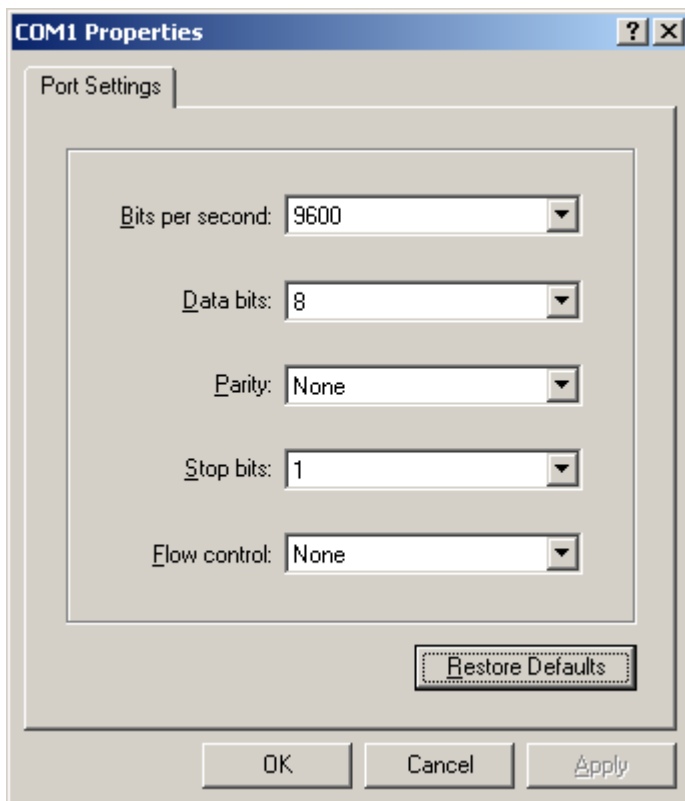

5. Select **File > Properties** in the HyperTerminal window.

Figure 74 HyperTerminal window

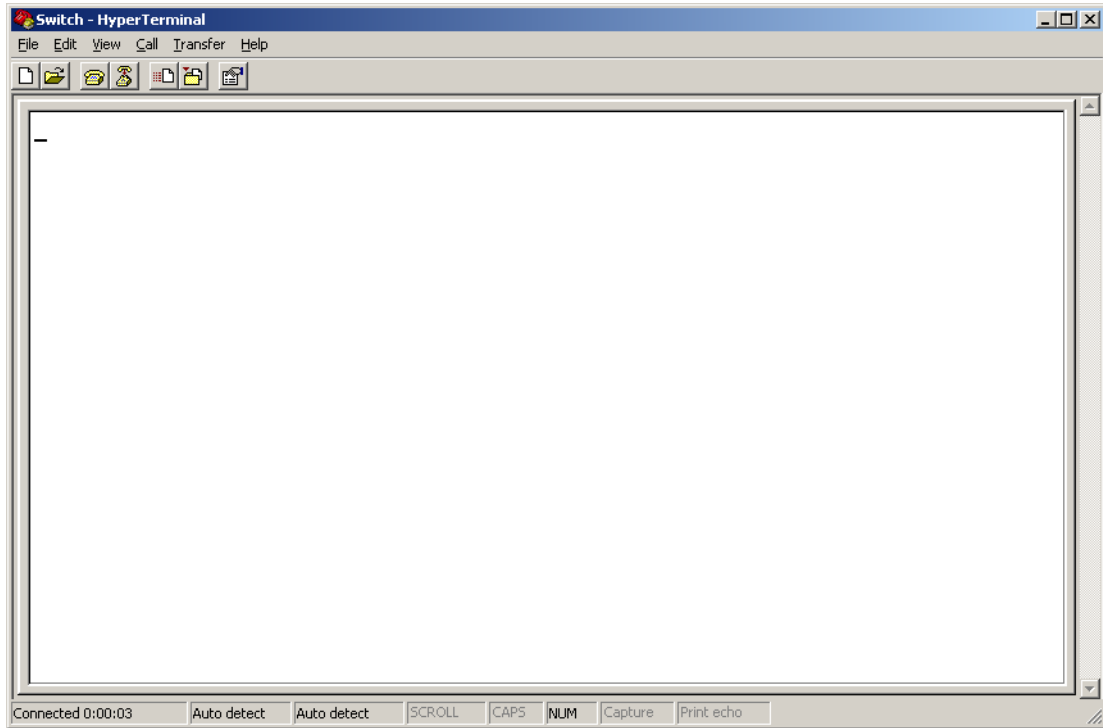

6. On the **Settings** tab, set the emulation to **VT100** and click **OK**.

Figure 75 Set terminal emulation in Switch Properties dialog box

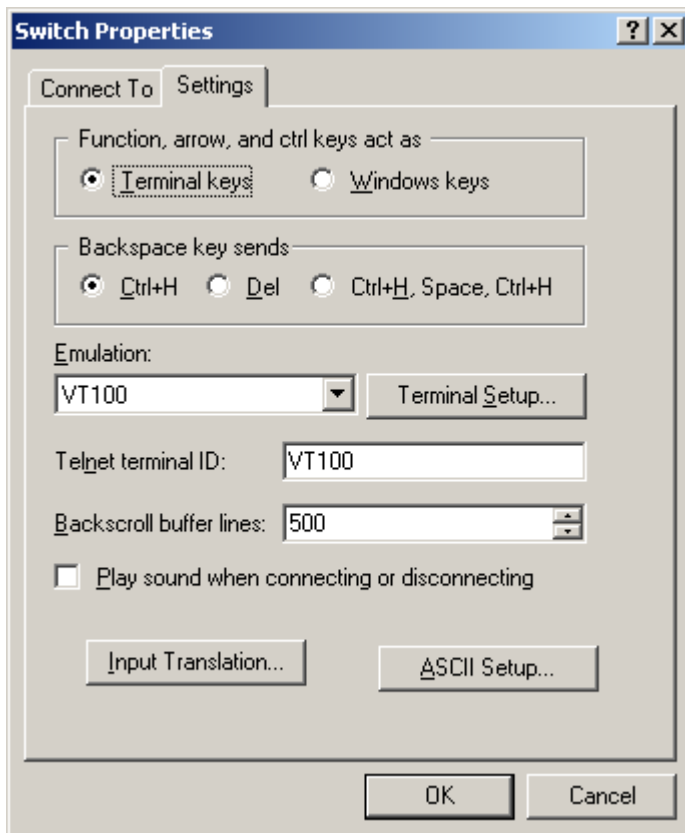

Powering on the switch

Verification before power-on

Before powering on the switch, verify that:

- The power cord is properly connected.
- The input power voltage meets the requirement of the switch.
- The console cable is properly connected, the terminal or PC used for configuration has started, and the configuration parameters have been correctly set.

Powering on the switch

Power on the switch, for example, a 5120-24G-PoE+ EI TAA (2 slots) switch, and you can see the following information:

Starting.....

```
*****
*
* HP 5120-24G-PoE+ EI TAA Switch with 2 Interface Slots BOOTROM, Version 205 *
*
*****

Copyright (c) 2010-2011 Hewlett-Packard Development Company, L.P.
Creation date   : Feb 23 2011, 09:36:58
CPU Clock Speed : 264MHz
BUS Clock Speed : 33MHz
Memory Size     : 128MB
Mac Address     : 3ce5a62f8dde
```

Press Ctrl-B to enter Boot Menu... 1

Press **Ctrl + B** at the prompt within one second to access the Boot menu, or wait for the system to automatically start up.

NOTE:

The system has two startup modes: full startup and fast startup. By default, the system starts up in fast mode and the waiting time is one second. In full startup mode, the waiting time is five seconds. To change the startup mode, see "[Changing the startup mode.](#)"

- If you press **Ctrl + B** within one second, the system displays a prompt for password:
Password:
Press **Enter** at the prompt the first time you access the switch and you can see the following Boot menu:

BOOT MENU

1. Download application file to flash
2. Select application file to boot

3. Display all files in flash
4. Delete file from flash
5. Modify bootrom password
6. Enter bootrom upgrade menu
7. Skip current configuration file
8. Set bootrom password recovery
9. Set switch startup mode
0. Reboot

Enter your choice(0-9):

Table 11 Boot menu options

Item	Description
1. Download application file to flash	Download a system software image file to the Flash memory.
2. Select application file to boot	Select the system software image file to boot.
3. Display all files in flash	Display all files in the Flash memory.
4. Delete file from flash	Delete files from the Flash memory.
5. Modify bootrom password	Modify the Boot ROM password.
6. Enter bootrom upgrade menu	Access the Boot ROM update menu.
7. Skip current configuration file	Start the switch with the factory default configuration. This is a one-time operation and does not take effect at the next reboot. You use this option when you forget the console login password.
8. Set bootrom password recovery	Disable or enable the Boot ROM password recovery function. By default, Boot ROM recovery is enabled. You can disable this function to protect system security.
9. Set switch startup mode	Set the startup mode to full mode or fast mode, as described in "Changing the startup mode."
0. Reboot	Restart the switch.

NOTE:

The system by default has no Boot ROM password. HP recommends that you set a Boot ROM password immediately after you access the Boot menu.

- If you perform no operation or press any key other than **Ctrl + B** within one second, the system automatically starts up when the remaining time becomes zero, and displays the following information:

```
Auto-booting...
Decompress Image.....
.....
.....
.....
.....
.....
.....
.....
.....
.....
.....
.....
```

```
.....
.....
.....
.....
.....
.....
.....OK!
```

User interface aux0 is available.

Press ENTER to get started.

Press **Enter** at the prompt, and you can configure the switch when the prompt <HP> appears.

Changing the startup mode

The system by default starts up in fast mode. To change to the full startup mode, press **Ctrl + B** within one second to access the Boot menu:

```
BOOT MENU
```

1. Download application file to flash
2. Select application file to boot
3. Display all files in flash
4. Delete file from flash
5. Modify bootrom password
6. Enter bootrom upgrade menu
7. Skip current configuration file
8. Set bootrom password recovery
9. Set switch startup mode
0. Reboot

Enter your choice(0-9):

Enter **9** to change the startup mode.

The current mode is fast startup mode!

Are you sure you want to change it to full startup mode? Yes or No(Y/N)

Enter **Y** at the prompt.

Setting startup mode...done!

```
BOOT MENU
```

1. Download application file to flash
2. Select application file to boot
3. Display all files in flash
4. Delete file from flash
5. Modify bootrom password
6. Enter bootrom upgrade menu
7. Skip current configuration file

User interface aux0 is available.

Press ENTER to get started.

Press **Enter** at the prompt, and you can configure the switch when the prompt <HP> appears.

NOTE:

For more information about the configuration commands and CLI, see the configuration guides and command references for your switch.

Setting up an IRF fabric

You can use HP Intelligent Resilient Framework (IRF) technology to connect and virtualize 5120 EI switches or 5120 SI switches into a virtual switch called an "IRF fabric" or "IRF virtual device" for flattened network topology, and high availability, scalability, and manageability.

NOTE:

- IRF is not available on the 5120-24G EI or 5120-48G EI switch. The "5120 EI switches" in this document does not include those two switch models.
- An IRF fabric cannot have both 5120 EI and 5120 SI switches.

IRF fabric setup flowchart

Figure 76 IRF fabric setup flowchart

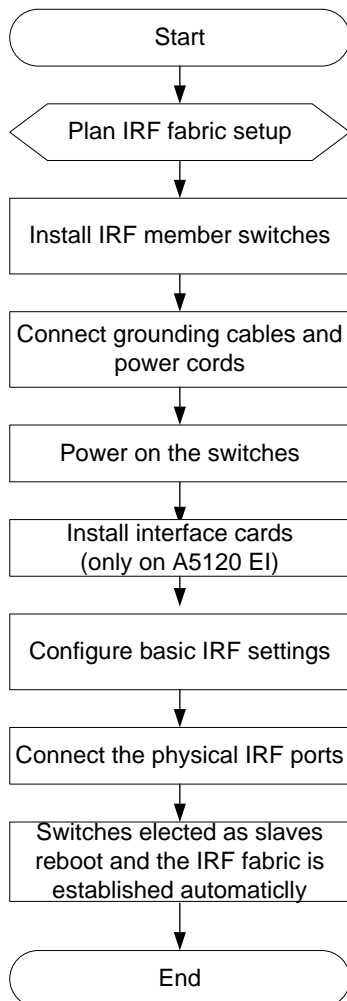

To set up an IRF fabric:

Step	Description
1. Plan IRF fabric setup	Plan the installation site and IRF fabric setup parameters: <ul style="list-style-type: none"> • Planning IRF fabric size and the installation site • Identifying the master switch and planning IRF member IDs • Planning IRF topology and connections • Identifying physical IRF ports on the member switches • Planning the cabling scheme
2. Install IRF member switches	See "Installing the switch."
3. Connect the grounding cable and power cords	See "Grounding the switch" and "Connecting the power cord."
4. Power on the switches	N/A
5. Install interface cards	This step is required only for the 5120 EI switches. See "Installing/removing an interface card (only for the 5120 EI switches)."
6. Configure basic IRF settings	See "Configuring basic IRF settings."
7. Connect the physical IRF ports	See "Connecting the physical IRF ports." All switches except the master switch automatically reboot, and the IRF fabric is established.

Planning IRF fabric setup

Planning IRF fabric size and the installation site

Choose switch models and identify the number of required IRF member switches, depending on the user density and upstream bandwidth requirements. The switching capacity of an IRF fabric equals the total switching capacities of all member switches.

NOTE:

As your business grows, you can plug a switch into an IRF fabric to increase the switching capacity without any topology change or replacement.

Identifying the master switch and planning IRF member IDs

Determine which switch you want to use as the master for managing all member switches in the IRF fabric. An IRF fabric has only one master switch. You configure and manage all member switches in the IRF fabric at the command line interface of the master switch.

NOTE:

IRF member switches will automatically elect a master. You can affect the election result by assigning a high member priority to the intended master switch. For more information about master election, see the IRF configuration guide for your switch.

Prepare an IRF member ID assignment scheme. An IRF fabric uses member IDs to uniquely identify and manage its members, and you must assign each IRF member switch a unique member ID.

Planning IRF topology and connections

You can create an IRF fabric in daisy chain topology, or more reliably, ring topology. In ring topology, the failure of one IRF link does not cause the IRF fabric to split as in daisy chain topology. Rather, the IRF fabric changes to a daisy chain topology without interrupting network services.

You connect the IRF member switches through IRF ports. An IRF port is a logical interface for the internal connection between IRF member switches. Each IRF member switch has two IRF ports: IRF-port 1 and IRF-port 2. To use an IRF port, you must bind physical ports to it.

When connecting two neighboring IRF member switches, you must connect the physical ports of IRF-port 1 on one switch to the physical ports of IRF-port 2 on the other switch.

You can bind several physical ports to an IRF port to create an aggregate IRF link for increased bandwidth and availability.

NOTE:

- Figure 77 and Figure 78 show the topologies of a 5120 EI IRF fabric. Figure 79 and Figure 80 show the topologies of a 5120-24G SI IRF fabric.
 - The IRF port connections in these figures are for illustration only, and more connection methods are available.
-

Figure 77 5120 EI IRF fabric in daisy chain topology

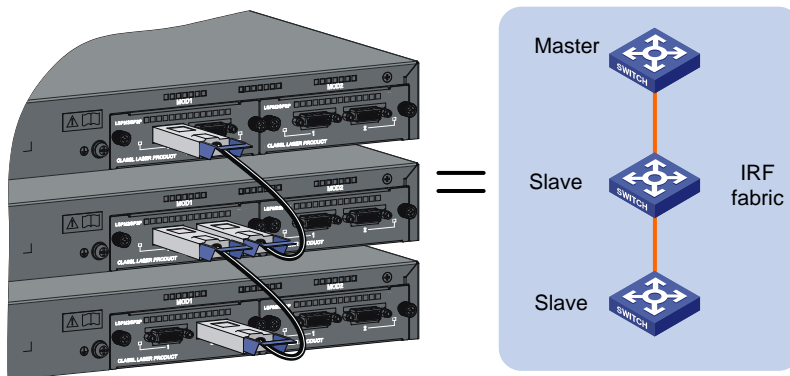

Figure 78 5120 EI IRF fabric in ring topology

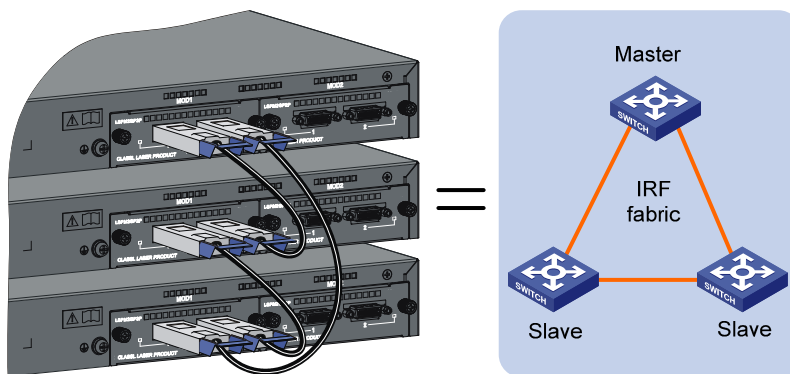

Figure 79 5120 SI IRF fabric in daisy chain topology

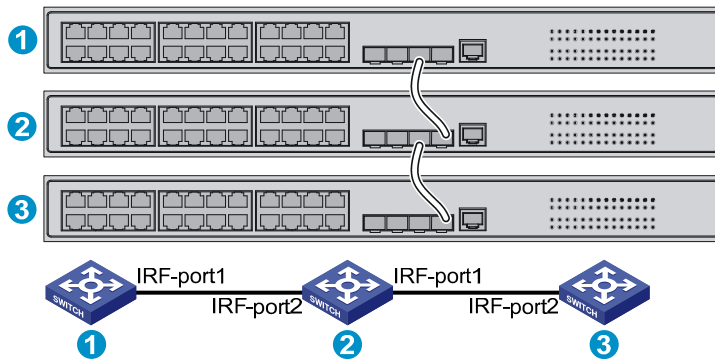
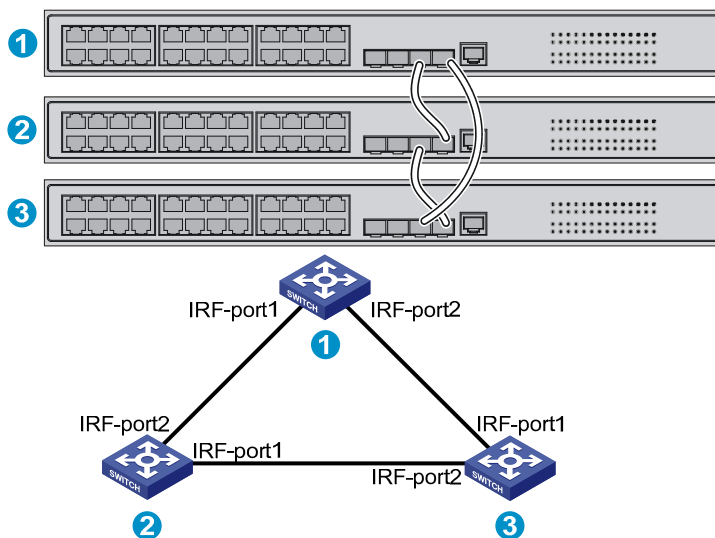

Figure 80 5120 SI IRF fabric in ring topology



Identifying physical IRF ports on the member switches

Identify the physical IRF ports on the member switches according to your topology and connection scheme.

Table 12 shows the physical ports that can be used for IRF connection and the port use restrictions.

Table 12 Physical IRF port requirements

Switch chassis	Candidate physical IRF ports	Requirements
5120 EI switches (excluding the 5120-24G EI and the 5120-48G EI)	Ports on the expansion interface cards on the rear panel	<ul style="list-style-type: none"> You must order interface cards separately. For long-distance connections, use XFP or SFP+ transceiver modules and fibers. For short-distance connections, use CX4 or SFP+ cables. For more information, see “Interface cards (only for the 5120 EI switches)” and “SFP/SFP+/XFP transceiver modules and SFP+/CX4 cables (only for the 5120 EI switches).” Ports assigned to the same IRF port must be on the same interface card. All 5120 EI switches in a ring topology and the non-edge switches in a daisy chain topology must have at least one two-port interface card or two one-port interface cards.
5120 SI switches	All network ports	<p>HP recommends that you use Gigabit SFP ports and HP A3600 Switch SFP Stacking Kit cables for IRF connection.</p> <p>For more information, see “SFP transceiver modules and SFP Stacking Kit (only for the 5120 SI switches).”</p>

Planning the cabling scheme

Planning the cabling scheme for a 5120 EI IRF fabric

If 2-port interface cards are used and the IRF links are not aggregate, follow these guidelines on connecting two neighboring 5120 EI switches:

- You can connect the interface card in slot 1 (MOD 1) on a member switch to the MOD 1 or MOD 2 card on its neighboring switch.
- Connect the left port on one interface card to the right port on the other interface card, as shown in [Figure 81](#).

Figure 81 Use 2-port interface cards to set up single-link IRF connection

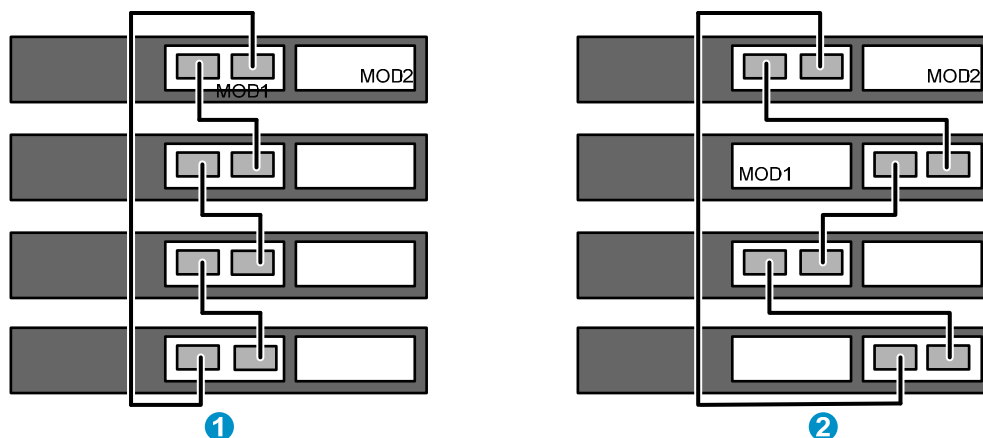

If 2-port interface cards are used and IRF links are aggregate, follow these guidelines on connecting two neighboring switches:

- The ports on the interface card MOD 1 on one switch must connect to the ports on the interface card MOD 2 on the other switch.
- A port on one interface card can connect to any port on the other interface card, as shown in [Figure 82](#). For example, you can connect the left port on one interface card to the left or right port on the other interface card.

Figure 82 Use 2-port interface cards to set up multi-link IRF connection

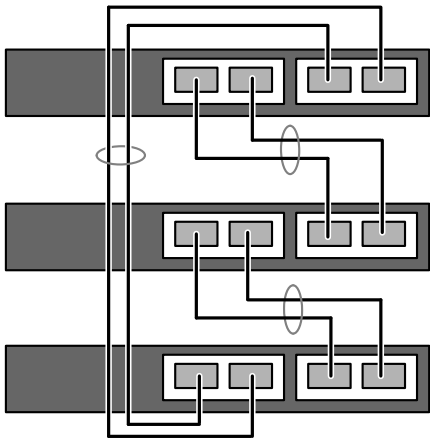

If 1-port interface cards are used, follow these guidelines on connecting neighboring switches:

- If both of the switches use 1-port interface cards, the port on MOD 1 on one switch must connect to the port on MOD 2 on the other switch (see callout 1 in [Figure 83](#)).
- If one switch uses a 1-port interface card but the other switch uses a 2-port interface card:
 - If the 1-port interface card is in the MOD 1 slot, the port on the card must connect to the right port on the 2-port interface card (see callout 2 in [Figure 83](#).)
 - If the 1-port interface card is in the MOD 2 slot, the port on the card must connect to the left port on the 2-port interface card.

Figure 83 Cable connections for an IRF fabric with 1-port interface cards

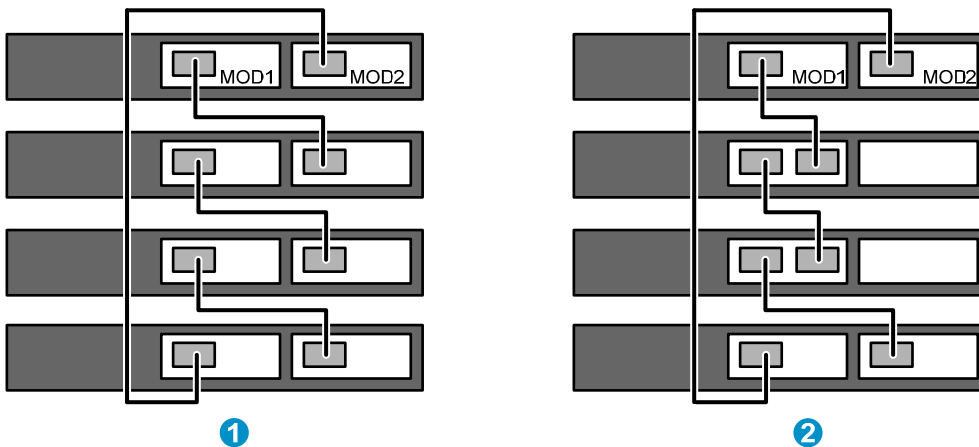

Planning the cabling scheme for a 5120 SI IRF fabric

HP recommends that you use Gigabit SFP ports and HP A3600 Switch SFP Stacking Kit cables for IRF connection.

Figure 84 shows two IRF connection schemes and uses Gigabit SFP ports and HP A3600 Switch SFP Stacking Kit cables for IRF connection. All these schemes use a ring topology.

Figure 85 shows the IRF fabric topology.

Figure 84 Connect the IRF member switches

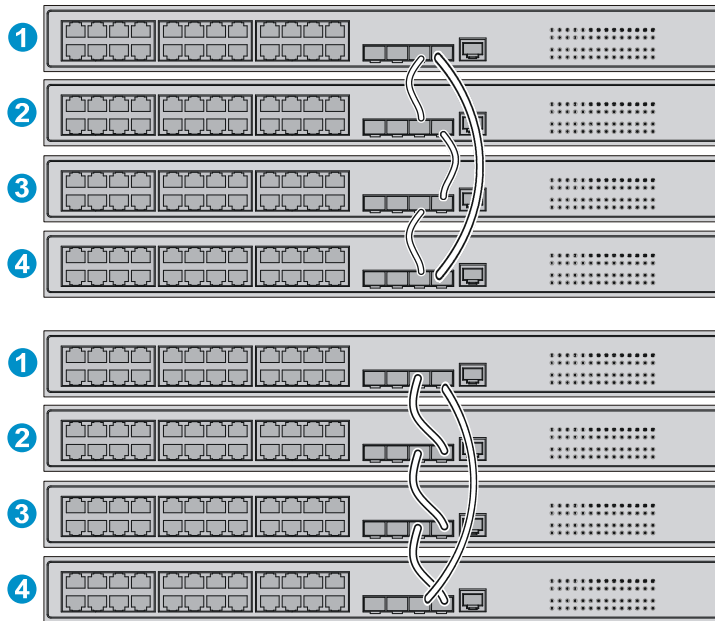
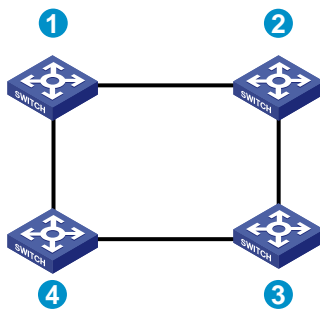

Figure 85 IRF fabric topology



Configuring basic IRF settings

After you install the IRF member switches, power on the switches, and log in to each IRF member switch (see the fundamentals configuration guide for your switch) to configure their member IDs, member priorities, and IRF port bindings.

Follow these guidelines when you configure the neighboring switches:

- Assign the master switch higher member priority than any other switch.
- Bind physical ports to IRF port 1 on one switch and to IRF port 2 on the other switch.

- Execute the **irf-port-configuration active** command to activate the IRF port configuration.
- Execute the **display irf configuration** command to verify the basic IRF settings.

For more information about configuring basic IRF settings, see the IRF configuration guide for your switch.

Connecting the physical IRF ports

Connect the IRF member switches as planned.

NOTE:

Wear an ESD-preventive wrist strap when you connect the physical IRF ports. For how to connect them, see *Pluggable SFP/SFP+/XFP Transceiver Modules Installation Guide*.

Accessing the IRF fabric to verify the configuration

To verify the basic functionality of the IRF fabric after you finish configuring basic IRF settings and connecting IRF ports:

1. Log in to the IRF fabric through the console port of any member switch.
2. Create a Layer 3 interface, assign it an IP address, and make sure that the IRF fabric and the remote network management station can reach each other.
3. Use Telnet, web or SNMP to access the IRF fabric from the network management station.
See the fundamentals configuration guide for your switch.
4. Check that you can manage all member switches as if they were one node.
5. Display the running status of the IRF fabric by using the commands in [Table 13](#).

Table 13 Display and maintain IRF configuration and running status

To do ...	Use the command...
Display information about the IRF fabric	display irf
Display all members' configurations that take effect after switch reboots	display irf configuration
Display topology information about the IRF fabric	display irf topology

NOTE:

To avoid IP address collision and network problems, configure at least one multi-active detection (MAD) mechanism to detect the presence of multiple identical IRF fabrics and handle collisions. For more information about MAD detection, see the IRF configuration guide for your switch.

Maintenance and troubleshooting

Password loss

Console login password loss

If you forget the console login password, access the Boot menu:

```
BOOT MENU
```

1. Download application file to flash
2. Select application file to boot
3. Display all files in flash
4. Delete file from flash
5. Modify bootrom password
6. Enter bootrom upgrade menu
7. Skip current configuration file
8. Set bootrom password recovery
9. Set switch startup mode
0. Reboot

Enter your choice(0-9):

Enter **7** and restart the switch. The switch reboots with empty configuration, and you can log in through the console port without entering the password to check the configuration file for the user password.

Boot ROM password loss

Contact the HP technical support for help.

Power supply failure

The 5120 EI switches and the 5120 SI switches use fixed power supplies. All 5120 EI switches and the 5120-24G-PoE+ SI switch support three power input modes: AC input, RPS DC input, and concurrent AC and RPS DC inputs. All other 5120 SI switches have only one AC power input.

To identify a power failure:

- On any 5120 EI switch, look at the system status LED and the RPS status LED of the switch. For more information, see [“LEDs \(for the 5120 EI switches\).”](#)
- On the 5120-24G-PoE+ SI switch, look at the power LED and the RPS status LED of the switch. For more information, see [“LEDs \(for the 5120 SI switches\).”](#)
- On any other 5120 SI switch, look at the power LED of the switch. For more information, see [“LEDs \(for the 5120 SI switches\).”](#)

NOTE:

In the following subsections, the system status LED collectively refers to both the system status LED on a 5120 EI switch and the power LED on a 5120 SI switch.

AC input

If the system status LED is off, an AC input failure has occurred. Verify the following items:

- The AC power cord is securely connected to the switch, and the AC-input power receptacle on the switch and the connected AC power outlet are in good condition.
- The external AC power system is correctly working.
- The operating temperature of the switch is in the normal range, and the power module has good ventilation. Over-temperature can cause the power module to stop working and enter the protection state.

RPS DC input

If the system status LED or RPS status LED is off, an RPS input failure has occurred. Verify the following items:

- The switch is securely connected to the RPS.
- The RPS is correctly working.
- The operating temperature of the switch is in the normal range, and the power supply has good ventilation. Over-temperature can cause the power supply to stop working and enter the protection state).

Concurrent RPS and AC inputs

1. If the system status LED is off, the AC power supply and the RPS both have an input failure.

Verify the following items:

- The AC power cord is securely connected to the switch, and the AC-input power receptacle on the switch and the connected AC power outlet are in good condition.
- The external AC power system is correctly working.
- The switch is securely connected to the RPS.
- The RPS is correctly working.
- The operating temperature of the switch is in the normal range, and the power supply has good ventilation. Over-temperature can cause the power supply to stop working and enter the protection state.

2. If the system status LED is on but the RPS status LED is steady yellow, an AC input failure has occurred.

Verify the following items:

- The AC power cord is securely connected to the switch, and the AC-input power receptacle on the switch and the connected AC power outlet are in good condition.
- The external AC power system is correctly working.

3. If the system status LED is on but the RPS status LED is off, an RPS input failure has occurred.

Verify the following items:

- The switch is securely connected to the RPS.
- The RPS is correctly working.

NOTE:

If the problem persists, contact the HP technical support for help.

Fan failure (only for the 5120 EI switches)

You can look at the system status LED and the seven-segment LED of a 5120 EI switch to identify a fan failure. If both LEDs are behaving as described in [Table 14](#), a fan failure occurs.

Table 14 LED behaviors that identify a fan failure

LED	Mark	State
System status LED	PWR	Steady red
		The LED flashes F for fan failure.
Seven-segment LED	Unit	

The 5120 EI switches use fixed fans. If a fan failure occurs, contact the HP technical support for help and do not attempt to fix the problem yourself.

Configuration terminal problems

If the configuration environment setup is correct, the configuration terminal displays booting information when the switch is powered on. If the setup is incorrect, the configuration terminal would display nothing or garbled text.

No terminal display

If the configuration terminal displays nothing after the switch is powered on, verify the following items:

- The power supply is supplying power to the switch.
- The console cable is properly connected.
- The console cable has no problem and the terminal settings are correct.

Garbled terminal display

If terminal display is garbled, verify that the following settings are configured for the terminal, for example, HyperTerminal:

- Baud rate—9,600
- Data bits—8
- Parity—none
- Stop bits—1
- Flow control—none
- Emulation—VT100

Appendix A Technical specifications

Physical specifications

Chassis dimensions and weights

Chassis	Dimensions (H x W x D)	Weight
5120-24G EI		
5120-24G EI (2 slots)	43.6 × 440 × 300 mm (1.72 × 17.32 × 11.81 in)	< 4.5 kg (9.92 lb)
5120-24G EI TAA (2 slots)		
5120-24G-PoE+ EI (2 slots)	43.6 × 440 × 420 mm	< 7.0 kg (15.43 lb)
5120-24G-PoE+ EI TAA (2 slots)	(1.72 × 17.32 × 16.54 in)	
5120-48G EI		
5120-48G EI (2 slots)	43.6 × 440 × 300 mm (1.72 × 17.32 × 11.81 in)	< 5 kg (11.02 lb)
5120-48G EI TAA (2 slots)		
5120-48G-PoE+ EI (2 slots)	43.6 × 440 × 420 mm	< 7.5 kg (16.53 lb)
5120-48G-PoE+ EI TAA (2 slots)	(1.72 × 17.32 × 16.54 in)	
5120-8G SI	43.6 × 210 × 210 mm (1.72 × 8.27 × 8.27 in)	≤ 2 kg (4.41 lb)
5120-16G SI		
5120-24G SI	43.6 × 440 × 160 mm (1.72 × 17.32 × 6.30 in)	≤ 3 kg (6.61 lb)
5120-8G-PPoE+ SI		
5120-8G-PoE+ SI	43.6 × 300 × 260 mm (1.72 × 11.81 × 10.24 in)	≤ 3 kg (6.61 lb)
5120-24G-PPoE+ SI		
5120-24G-PoE+ SI	43.6 × 440 × 420 mm (1.72 × 17.32 × 16.54 in)	≤ 7 kg (15.43 lb)
5120-48G SI	43.6 × 440 × 260 mm (1.72 × 17.32 × 10.24 in)	≤ 5 kg (11.02 lb)

Ports and interface card slots

Chassis	Console ports	10/100/1000Base-T auto-sensing Ethernet ports	1000Base-X SFP ports	Interface card slots
5120-24G EI	1	24	4	N/A
5120-24G EI (2 slots)				
5120-24G EI TAA (2 slots)	1	24	4	2
5120-24G-PoE+ EI (2 slots)				
5120-24G-PoE+ EI TAA (2 slots)	1	24, PoE+	4	2
5120-48G EI	1	48	4	N/A

Chassis	Console ports	10/100/1000Base-T auto-sensing Ethernet ports	1000Base-X SFP ports	Interface card slots
5120-48G EI (2 slots)	1	48	4	2
5120-48G EI TAA (2 slots)				
5120-48G-PoE+ EI (2 slots)	1	48, PoE+	4	2
5120-48G-PoE+ EI TAA (2 slots)				
5120-8G SI	1	8	1	N/A
5120-16G SI	1	16	4	N/A
5120-24G SI	1	24	4	N/A
5120-8G-PoE+ SI	1	8, PoE+	1	N/A
5120-8G-PPoE+ SI	1	8, PPoE+	1	N/A
5120-24G-PoE+ SI	1	24, PoE+	4	N/A
5120-24G-PPoE+ SI	1	24, PPoE+	4	N/A
5120-48G SI	1	48	4	N/A

NOTE:

On a 5120 EI switch, the last four 10/100/1000Base-T Ethernet ports and the four SFP ports are copper/fiber combo ports in pairs, as shown in [Table 17](#). They form four combo interfaces. When one port in a pair is activated, the other port automatically shuts down.

Environmental specifications

Chassis	Operating temperature	Relative humidity
All chassis	0°C to 45°C (32°F to 113°F)	10% to 90%, noncondensing

Power specifications

Power input types

Chassis	AC-input power receptacle	RPS receptacle
All 5120 EI chassis, 5120-24G-PoE+ SI	1	1
All 5120 SI chassis but the 5120-24G-PoE+ SI	1	N/A

The RPS can supply power to your switch when the AC power line fails or cannot supply sufficient power.

AC input voltage specifications

Chassis	Rated voltage range	Max voltage range
All chassis	100 VAC to 240 VAC, 50 Hz or 60 Hz	90 VAC to 264 VAC, 47 Hz to 63 Hz

RPS DC input voltage specifications and RPS compatibility

Chassis	RPS input rated voltage range	Compatible RPS
5120-24G EI	10.8 VDC to 13.2 VDC	A-RPS800 (JD183A)
5120-24G EI (2 slots)		
5120-24G EI TAA (2 slots)		
5120-48G EI		
5120-48G EI (2 slots)		
5120-48G EI TAA (2 slots)		
5120-24G-PoE+ EI (2 slots)	-52 VDC to -55 VDC	A-RPS1600 (JG136A)
5120-24G-PoE+ EI TAA (2 slots)		
5120-48G-PoE+ EI (2 slots)		
5120-48G-PoE+ EI TAA (2 slots)		
5120-24G-PoE+ SI	-52 VDC to -55 VDC	A-RPS1600 (JG136A)

Power consumption specifications for non-PoE switches

Chassis	Minimum power consumption	Maximum power consumption
5120-24G EI	35 W	62 W
5120-24G EI (2 slots)	36 W	103 W
5120-24G EI TAA (2 slots)		
5120-48G EI	54 W	110 W
5120-48G EI (2 slots)	55 W	145 W
5120-48G EI TAA (2 slots)		
5120-8G SI	8.7 W	14.4 W
5120-16G SI	11.9 W	25.1 W
5120-24G SI	13.4 W	31.5 W
5120-48G SI	25.7 W	59.8 W

Power consumption specifications for PoE switches

Chassis	Maximum PoE power per port	Total PoE output	Minimum power consumption	Maximum power consumption (including total PoE output)
5120-24G-PoE+ EI (2 slots) 5120-24G-PoE+ EI TAA (2 slots)	30 W	370 W	62 W	585 W at AC input 491 W at RPS DC input
5120-48G-PoE+ EI (2 slots) 5120-48G-PoE+ EI TAA (2 slots)	30 W	370 W at AC input 740 W at RPS DC input (370 W for ports 1 to 24, and 370 W for ports 25 to 48)	90 W	651 W at AC input 921 W at RPS DC input
5120-8G-PoE+ SI	30 W	180 W	19 W	230 W
5120-8G-PPoE+ SI	30 W	65 W	10 W	95 W
5120-24G-PoE+ SI	30 W	370 W at AC input 740 W at RPS DC input	45.6 W at AC input 27.5 W at RPS DC input	528 W at AC input 832 W at RPS DC input
5120-24G-PPoE+ SI	30 W	170 W	25.0 W	255 W

Cooling system

All 5120 EI and 5120 SI switches use fixed fans for heat dissipation, and the airflow is from left to right.

Chassis	Fixed fans
5120-24G EI 5120-24G EI (2 slots) 5120-24G EI TAA (2 slots)	4
5120-48G EI 5120-48G EI (2 slots) 5120-48G EI TAA (2 slots)	
5120-24G-PoE+ EI (2 slots) 5120-24G-PoE+ EI TAA (2 slots) 5120-48G-PoE+ EI (2 slots) 5120-48G-PoE+ EI TAA (2 slots)	
5120-8G SI 5120-16G SI 5120-24G SI 5120-48G SI	

Chassis	Fixed fans
5120-8G-PPoE+ SI	1
5120-8G-PoE+ SI	3
5120-24G-PPoE+ SI	3
5120-24G-PoE+ SI	6

Appendix B FRUs and compatibility matrixes

This appendix describes the FRUs available for the 5120 EI and 5120 SI switches and their compatibility.

Interface cards (only for the 5120 EI switches)

The interface cards in this section are available for all 5120 EI switches but the 5120-24G EI and 5120-48G EI switches.

Card model	Product code	Description	Support for IRF	Compatible transceiver modules/cables
LSPM2GP2P	JD367A	Provides two Gbps SFP fiber ports	No	See "GE SFP transceiver modules." NOTE: The card does not support the transceiver module coded JD089B.
LSPM2SP2P	JD368B	Provides two 10 Gbps SFP+ fiber ports	Yes	See "10-GE SFP+ transceiver modules" and "SFP+ cables."
LSPM1XP2P	JD359B	Provides two 10 Gbps XFP fiber ports	Yes	See "10-GE XFP transceiver modules."
LSPM1XP1P	JD361B	Provides one 10 Gbps XFP fiber port	Yes	See "10-GE XFP transceiver modules."
LSPM1CX2P	JD360B	Provides two 10 Gbps copper ports	Yes	See "CX4 cables."

NOTE:

For more information about the interface cards, see the user guides for the interface cards.

SFP/SFP+/XFP transceiver modules and SFP+/CX4 cables (only for the 5120 EI switches)

NOTE:

- To guarantee the functionality of the SFP/SFP+/XFP ports, use only HP transceiver modules.
- The transceiver modules available for this switch series are subject to change over time. For the most up-to-date list of transceiver modules, consult your HP sales representative or technical support engineer.
- For the transceiver module specifications, see HP A-Series Switches Transceiver Modules User Guide. For information about installing a transceiver module, see *Pluggable SFP/SFP+/XFP Transceiver Modules Installation Guide*.

GE SFP transceiver modules

Product code	Module description	Central wavelength (nm)	Cable/fiber diameter (μm)	Multimode fiber modal bandwidth (MHz × km)	Max transmission distance
JD118B	HP X120 1G SFP LC SX Transceiver	850	50/125	500	550 m (1804.46 ft)
				400	500 m (1640.42 ft)
			62.5/125	200	275 m (902.23 ft)
				160	220 m (721.78 ft)
JD119B	HP X120 1G SFP LC LX Transceiver	1310	9/125	N/A	10 km (6.21 miles)
			50/125	500, 400	550 m (1804.46 ft)
			62.5/125	500	550 m (1804.46 ft)
JD061A	HP X125 1G SFP LC LH40 1310nm Transceiver	1310	9/125	N/A	40 km (24.86 miles)
JD062A	HP X120 1G SFP LC LH40 1550nm Transceiver	1550	9/125	N/A	40 km (24.86 miles)
JD063B	HP X125 1G SFP LC LH70 Transceiver	1550	9/125	N/A	70 km (43.50 miles)
JD103A	HP X120 1G SFP LC LH100 Transceiver	1550	9/125	N/A	100 km (62.14 miles)
JD098B	HP X120 1G SFP LC BX 10-U Transceiver	TX: 1310nm RX: 1490nm	9/125	N/A	10 km (6.21 miles)
JD099B	HP X120 1G SFP LC BX 10-D Transceiver	TX: 1490nm RX: 1310nm	9/125	N/A	10 km (6.21 miles)
JD089B	HP X120 1G SFP RJ45 T Transceiver	N/A	Category-5 twisted pair	N/A	100 m (328.08 ft)

ⓘ IMPORTANT:

You must use the transceiver modules coded JD098B and JD099B in pairs.

10-GE SFP+ transceiver modules

Product code	Module description	Central wavelength (nm)	Fiber diameter (μm)	Multimode fiber modal bandwidth (MHz × km)	Max transmission distance
JD092B	HP X130 10G SFP+ LC SR	850	50/125	2000	300 m (984.25 ft)

Product code	Module description	Central wavelength (nm)	Fiber diameter (μm)	Multimode fiber modal bandwidth (MHz × km)	Max transmission distance
				500	82 m (269.03 ft)
				400	66 m (216.54 ft)
			62.5/125	200	33 m (108.27 ft)
				160	26 m (85.3 ft.)
JD093B	HP X130 10G SFP+ LC LRM Transceiver	1310	50/125	1500, 500	220 m (721.78 ft)
				400	100 m (328.08 ft)
			62.5/125	200, 160	220 m (721.78 ft)
JD094B	HP X130 10G SFP+ LC LR Transceiver	1310	9/125	N/A	10 km (6.21 miles)
JG234A	HP X130 10G SFP+ LC ER 40km Transceiver	1550	9/125	N/A	40 km (24.86 miles)

NOTE:

For the SFP+ cables available for connecting the SFP+ ports, see “[SFP+ cables.](#)”

SFP+ cables

Product code	Cable description	Cable length
JD095C	HP X240 10G SFP+ SFP+ 0.65m DA Cable	0.65 m (2.13 ft)
JD096C	HP X240 10G SFP+ SFP+ 1.2m DA Cable	1.2 m (3.94 ft)
JD097C	HP X240 10G SFP+ SFP+ 3m DA Cable	3 m (9.84 ft)
JG081C	HP X240 10G SFP+ SFP+ 5m DA Cable	5 m (16.40 ft)

Figure 86 SFP+ cable



(1) Pull latch

(2) Connector

10-GE XFP transceiver modules

Product code	Module description	Central wavelength (nm)	Fiber diameter (μm)	Multimode fiber modal bandwidth (MHz \times km)	Max transmission distance
JD117B	HP X130 10G XFP LC SR Transceiver	850	50/125	2000	300 m (984.25 ft)
				500	82 m (269.03 ft)
				400	66 m (216.54 ft)
				220	33 m (108.27 ft)
				160	26 m (85.3 ft)
JD108B	HP X130 10G XFP LC LR 1310nm Transceiver	1310	9/125	N/A	10 km (6.21 miles)
JD121A	HP X135 10G XFP LC ER Transceiver	1550	9/125	N/A	40 km (24.86 miles)
JD107A	HP X130 10G XFP LC ZR 1550nm Transceiver	1550	9/125	N/A	80 km (49.71 miles)

CX4 cables

Product code	Cable description	Connector type	Cable length
JD363B	HP X230 Local Connect 50cm CX4 Cable	4X Infiniband	0.5 m (19.69 in)
JD364B	HP X230 Local Connect 100cm CX4 Cable	4X Infiniband	1 m (39.37 in)
JD365A	HP X230 CX4 to CX4 3m Cable	4X Infiniband	3 m (118.11 in)

Figure 87 CX4 cable

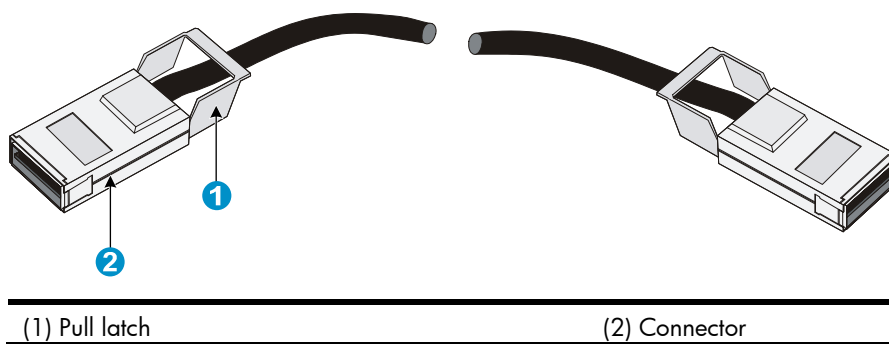

(1) Pull latch

(2) Connector

SFP transceiver modules and SFP Stacking Kit (only for the 5120 SI switches)

NOTE:

- To guarantee the functionality of the SFP ports, use only HP SFP transceiver modules.
- The SFP transceiver modules available for this switch series are subject to change over time. For the most up-to-date list of SFP transceiver modules, consult your HP sales representative or technical support engineer.
- For the SFP transceiver module specifications, see *HP A-Series Switches Transceiver Modules User Guide*.

Product code	Module description	Central wavelength (nm)	Cable/fiber diameter (μm)	Multimode fiber modal bandwidth (MHz × km)	Maximum transmission distance
JD118B	HP X120 1G SFP LC SX Transceiver	850	50/125	500	550 m (1804.46 ft)
				400	500 m (1640.42 ft)
			62.5/125	200	275 m (902.23 ft)
				160	220 m (721.78 ft)
JD119B	HP X120 1G SFP LC LX Transceiver	1310	9/125	N/A	10 km (6.21 miles)
			50/125	500, 400	550 m (1804.46 ft)
			62.5/125	500	550 m (1804.46 ft)
JD061A	HP X125 1G SFP LC LH40 1310nm Transceiver	1310	9/125	N/A	40 km (24.86 miles)
JD062A	HP X120 1G SFP LC LH40 1550nm Transceiver	1550	9/125	N/A	40 km (24.86 miles)
JD063B	HP X125 1G SFP LC LH70 Transceiver	1550	9/125	N/A	70 km (43.50 miles)
JD098B	HP X120 1G SFP LC BX 10-U Transceiver	TX: 1310nm RX: 1490nm	9/125	N/A	10 km (6.21 miles)
JD099B	HP X120 1G SFP LC BX 10-D Transceiver	TX: 1490nm RX: 1310nm	9/125	N/A	10 km (6.21 miles)
JD089B	HP X120 1G SFP RJ45 T Transceiver	N/A	Category-5 twisted pair	N/A	100 m (328.08 ft)
JD324A	HP A3600 Switch SFP Stacking Kit	N/A	UTP/STP	N/A	1.5 m (4.92 ft)



IMPORTANT:

You must use the transceiver modules coded JD098B and JD099B in pairs.

Appendix C Ports and LEDs

Ports

Console port

Every 5120 EI or 5120 SI switch provides one console port on the front panel.

Table 15 Console port specifications

Item	Specification
Connector type	RJ-45
Compliant standard	EIA/TIA-232
Transmission baud rate	9600 bps (default) to 115200 bps
Service	<ul style="list-style-type: none">• Provides connection to an ASCII terminal.• Provides connection to the serial port of a local or remote (through a pair of modems) PC running terminal emulation program.

10/100/1000Base-T Ethernet port

Table 16 10/100/1000Base-T Ethernet port specifications

Item	Specification
Connector type	RJ-45
Interface standard	<ul style="list-style-type: none">• 10 Mbps, half/full duplex• 100 Mbps, half/full duplex• 1000 Mbps, full duplex• MDI/MDI-X, auto-sensing
Max transmission distance	100 m (328.08 ft)
Transmission medium	Category-5 (or above) twisted pair cable
Standards	IEEE 802.3i, 802.3u, 802.3ab

SFP port

All 5120 EI and 5120 SI switches have 1000Base-X SFP ports. For the SFP transceiver modules available for the 5120 EI switches, see [“GE SFP transceiver modules.”](#) For the SFP transceiver modules available for the 5120 SI switches, see [“SFP transceiver modules and SFP Stacking Kit \(only for the 5120 SI switches\).”](#)

Combo interface (only available on the 5120 EI switches)

On a 5120 EI switch, the last four 10/100/1000Base-T Ethernet ports and the four SFP ports are copper/fiber combo ports in pairs, as shown in [Table 17](#). They form four combo interfaces. When one port in a pair is activated, the other port automatically shuts down. For more information about combo interfaces, see *HP 5120 EI Switch Series Configuration Guides*.

Table 17 Copper/fiber combo ports in pairs

Chassis	SFP port	10/100/1000Base-T Ethernet port
5120-24G EI (2 slots)	GigabitEthernet 1/0/25	GigabitEthernet 1/0/22
5120-24G EI TAA (2 slots)	GigabitEthernet 1/0/26	GigabitEthernet 1/0/24
5120-24G-PoE+ EI (2 slots)	GigabitEthernet 1/0/27	GigabitEthernet 1/0/21
5120-24G-PoE+ EI TAA (2 slots)	GigabitEthernet 1/0/28	GigabitEthernet 1/0/23
5120-48G EI (2 slots)	GigabitEthernet 1/0/49	GigabitEthernet 1/0/46
5120-48G EI TAA (2 slots)	GigabitEthernet 1/0/50	GigabitEthernet 1/0/48
5120-48G-PoE+ EI (2 slots)	GigabitEthernet 1/0/51	GigabitEthernet 1/0/45
5120-48G-PoE+ EI TAA (2 slots)	GigabitEthernet 1/0/52	GigabitEthernet 1/0/47

LEDs (for the 5120 EI switches)

Table 18 LEDs at a glance

LED	Availability
System status LED	Entire series
RPS status LED	Entire series
Port mode LED	Entire series
Seven-segment LED	Entire series
10/100/1000Base-T Ethernet port LED	Entire series
SFP port LED	Entire series
Interface card status LED	Entire series (except the 5120-24G EI and 5120-48G EI)

System status LED

The system status LED shows the operating status of the switch.

Table 19 System status LED description

LED mark	Status	Description
PWR	Steady green	The switch is operating properly.
	Flashing green (1 Hz)	The switch is performing power-on self test (POST).

LED mark	Status	Description
	Steady red	POST has failed.
	Flashing yellow (1 Hz)	Some ports have failed to pass POST.
	Off	The switch is powered off.

RPS status LED

The RPS status LED shows the operating status of the RPS DC input.

Table 20 RPS status LED description for the non-PoE switches

LED mark	Status	Description
RPS	Steady green	Both the RPS DC input and the AC input are normal, or an RPS is connected and the AC input is normal.
	Steady yellow	The RPS DC input is normal, but the AC input is disconnected or has failed.
	Off	No RPS is connected.

Table 21 RPS status LED description for the PoE switches

LED mark	Status	Description
RPS	Steady green	Both the RPS DC input and the AC input are normal.
	Steady yellow	The RPS power input is normal, but the AC input is disconnected or has failed.
	Off	The RPS power input is abnormal or no RPS is connected.

Port mode LED

The port mode LED indicates the type of information that the network port LEDs are showing. You can use the port LED mode switching button to change the type of displayed port information.

Table 22 Port mode LED description

LED mark	Status	Description
Mode	Steady green	The network port LEDs are showing port rates.
	Flashing green (1 Hz) (available only for the PoE switches)	The network port LEDs are showing the status of PoE power supply on the ports.
	Steady yellow	The network port LEDs are showing duplex modes.

Seven-segment LED

The seven-segment LED, together with the system status LED, shows detailed system operating information (see [Table 23](#)).

The seven-segment LED can also show the total PoE output power as a percentage of the maximum PoE output power that a PoE switch can supply (see [Table 24](#)). The PoE switches include 5120-24G-PoE+ EI (2 slots), 5120-24G-PoE+ EI TAA (2 slots), 5120-48G-PoE+ EI (2 slots), and 5120-48G-PoE+ EI TAA (2 slots).

Table 23 Seven-segment LED description (I)











System status LED (PWR) status	Seven-segment LED (Unit) status	Description
Flashing green	The LED displays numbers one by one. 	POST is running, and the LED displays the ongoing test item ID.
Flashing red	The LED displays flashing numbers. 	POST has failed, and the LED flashes the ID of the failed test item.
Flashing green	A bar rotates clockwise around the LED. 	Software is loading.
Steady red	The LED displays a flashing F character. 	The switch is experiencing a fan failure.
Steady red	The LED displays a flashing t character. 	The switch is in an over-temperature condition.
	The LED displays a capital C character. 	The switch is the command switch in a cluster.
	The LED displays an S character. 	The switch is a member switch in a cluster.
Steady green	The LED displays a lowercase c character. 	The switch is a candidate switch for a cluster.
	The LED displays a number. 	The member ID of the switch in an IRF fabric. The 5120-24G EI and 5120-48G EI switches do not support IRF.

Table 24 Seven-segment LED description (II)

Port mode LED (Mode) status	System status LED (PWR) status	Seven-segment LED (Unit) status	Description
Flashing green (1 Hz) (PoE mode)	Steady green	The LED displays different signs. 	For example, the  sign indicates that the switch is outputting 0 to 20% of the maximum PoE output power.

10/100/1000Base-T Ethernet port LED

Each 10/100/1000Base-T auto-sensing Ethernet port has a status LED to show port operating status and activities. The port mode LED indicates the type of information (for example, port rate or duplex mode) that the port LEDs are showing. You can use the port LED mode switching button to change the type of displayed port information.

Table 25 10/100/1000Base-T auto-sensing Ethernet port LEDs description

Port mode LED (Mode) status	Port LED status	Description
Steady green (rate mode)	Steady green	The port is operating at 1000 Mbps. The port LED fast flashes when the port is sending or receiving data.
	Steady yellow	The port is operating at 10/100 Mbps. The port LED fast flashes when the port is sending or receiving data.
	Flashing yellow (3 Hz)	POST has failed on the port.
	Off	No link is present on the port.
Flashing green (1 Hz) (PoE mode, available only for PoE switches)	Steady green	PoE power supply is normal.
	Flashing green (1 Hz)	The device attached to the port requires power higher than the maximum or currently available PoE output power on the port.
	Steady yellow	The port is experiencing a PoE failure. The port is not supplying power, because the device attached to the port is not a powered device.
	Flashing yellow (3 Hz)	POST has failed on the port.
	Off	The port is not supplying PoE power.
Steady yellow (duplex mode)	Steady green	The port is operating in full duplex mode. The port LED fast flashes when the port is sending or receiving data.
	Steady yellow	The port is operating in half duplex mode. The port LED fast flashes when the port is sending or receiving data.
	Flashing yellow (3 Hz)	POST has failed on the port.
	Off	No link is present on the port.

SFP port LED

Each 1000Base-X SFP port has a status LED to show port operating status and activities. The port mode LED indicates the type of information (for example, port rate or duplex mode) that the port LEDs are showing. You can use the port LED mode switching button to change the type of displayed port information.

Table 26 SFP port LEDs description

Port mode LED (Mode) status	Port LED status	Description
Steady green (rate mode) or flashing green (1 Hz, PoE mode)	Steady green	The port is operating at 1000 Mbps. The port LED fast flashes when the port is sending or receiving data.
	Flashing yellow (3 Hz)	POST has failed on the port.
	Off	No link is present on the port.
Steady yellow (duplex mode)	Steady green	The port is operating in full duplex mode. The port LED fast flashes when the port is sending or receiving data.
	Flashing yellow (3 Hz)	POST has failed on the port.
	Off	No link is present on the port.

Interface card status LED

Table 27 Interface card status LED description

LED mark	Status	Description
MOD1 MOD2	Green	The interface card is in position and operating properly.
	Flashing yellow	The switch does not support the interface card model, or the interface card has failed.
	Off	The expansion interface card slot is empty.

LEDs (for the 5120 SI switches)

Table 28 LEDs at a glance

LED	Availability
Power LED	Entire series
RPS status LED	5120-24G-PoE+ SI
Port mode LED	5120-8G-PPoE+ SI, 5120-8G-PoE+ SI, 5120-24G-PPoE+ SI, 5120-24G-PoE+ SI
10/100/1000Base-T Ethernet port LED	Entire series
1000Base-X SFP port LED	Entire series

Power LED

The power LED shows the operation status of the switch.

Table 29 Power LED description

LED mark	Status	Description
Power	Steady green	The switch is operating properly.

LED mark	Status	Description
	Flashing green (1 Hz)	The system is performing power-on self test (POST) or downloading software.
	Flashing green (3 Hz)	POST has failed or another fatal error has been detected.
	Off	The switch has been powered off.

RPS status LED

The 5120-24G-PoE+ SI switch has one RPS status LED on its front panel to show the operating status of the RPS DC input.

Table 30 RPS status LED description

LED mark	Status	Description
RPS	Steady green	The RPS DC input is normal.
	Off	The RPS unit is not connected or the RPS DC input is abnormal.

Port mode LED

The 5120-8G-PPoE+ SI, 5120-8G-PoE+ SI, 5120-24G-PPoE+ SI and 5120-24G-PoE+ SI switches have a port mode LED to indicate the type of information that the network port LEDs (excluding the SFP port LEDs) are showing. You can use the port LED mode switching button to change the type of displayed port information.

Table 31 Port mode LED description

LED mark	Status	Description
Mode	Steady green	The network port LEDs are showing port rates.
	Flashing green (1 Hz)	The network port LEDs are showing the status of PoE power supply on the ports.

10/100/1000Base-T Ethernet port LED

The 5120-48G SI switch has one bi-color LED (see [Table 32](#)) for each 10/100/1000Base-T Ethernet port, and all other 5120 SI switches have two LEDs (see [Table 33](#)) for each 10/100/1000Base-T Ethernet port. The 5120-8G-PPoE+ SI, 5120-24G-PoE+ SI, 5120-24G-PPoE+ SI, and 5120-24G-PoE+ SI switches also use a port mode LED to indicate the type of information that the port LEDs are displaying (see [Table 34](#)).

Table 32 Ethernet port LED description (5120-48G SI)

Status	Description
Steady green	The port is operating at 1000 Mbps.
Fast flashing green	The port is sending or receiving data at 1000 Mbps.
Steady yellow	The port is operating at 10/100 Mbps.
Fast flashing yellow	The port is sending or receiving data at 10/100 Mbps.

Status	Description
Off	No link is present on the port.

Table 33 Ethernet port LEDs description (5120-16G SI/5120-24G SI)

LED	Status	Description
Green	On	The port is operating at 1000 Mbps.
	Fast flashing	The port is sending or receiving data at 1000 Mbps.
	Off	The port has no link or is not operating at 1000 Mbps.
Yellow	On	The port is operating at 10/100 Mbps.
	Fast flashing	The port is sending or receiving data at 10/100 Mbps.
	Off	The port has no link or is not operating at 10/100 Mbps.

Table 34 Ethernet port LED description (5120-24G-PPoE+ SI/5120-24G-PoE+ SI)

Port mode LED (Mode) status	Port LED	Port LED status	Description
Steady green (rate mode)	Green	On	The port is operating at 1000 Mbps.
		Fast flashing	The port is sending or receiving data at 1000 Mbps.
		Off	The port has no link or is not operating at 1000 Mbps.
	Yellow	On	The port is operating at 10/100 Mbps.
		Fast flashing	The port is sending or receiving data at 10/100 Mbps.
		Off	No link is present on the port.
Flashing green (PoE mode)	Green	On	PoE power supply is normal.
		Flashing at 3 Hz	The device attached to the port requires power higher than the maximum or currently available PoE output power on the port.
		Off	The port is not supplying power.
	Yellow	On	The device attached to the port is not a powered device or a PoE failure has occurred.
		Off	The port is supplying power normally or not supplying power.

1000Base-X SFP port LED

Table 35 1000Base-X SFP port LEDs description

Status	Description
Steady green	The port is operating at 1000 Mbps.
Flashing green	The port is sending or receiving data.
Off	No link is present on the port.

Support and other resources

Contacting HP

For worldwide technical support information, see the HP support website:

<http://www.hp.com/support>

Before contacting HP, collect the following information:

- Product model names and numbers
- Technical support registration number (if applicable)
- Product serial numbers
- Error messages
- Operating system type and revision level
- Detailed questions

Subscription service

HP recommends that you register your product at the Subscriber's Choice for Business website:

<http://www.hp.com/go/wwalerts>

After registering, you will receive email notification of product enhancements, new driver versions, firmware updates, and other product resources.

Related information

Documents

To find related documents, browse to the Manuals page of the HP Business Support Center website:

<http://www.hp.com/support/manuals>

- For related documentation, navigate to the Networking section, and select a networking category.
- For a complete list of acronyms and their definitions, see *HP A-Series Acronyms*.

Websites

- HP.com <http://www.hp.com>
- HP Networking <http://www.hp.com/go/networking>
- HP manuals <http://www.hp.com/support/manuals>
- HP download drivers and software <http://www.hp.com/support/downloads>
- HP software depot <http://www.software.hp.com>
- HP Education <http://www.hp.com/learn>

Conventions

This section describes the conventions used in this documentation set.





Command conventions

Convention	Description
Boldface	Bold text represents commands and keywords that you enter literally as shown.
<i>Italic</i>	<i>Italic</i> text represents arguments that you replace with actual values.
[]	Square brackets enclose syntax choices (keywords or arguments) that are optional.
{ x y ... }	Braces enclose a set of required syntax choices separated by vertical bars, from which you select one.
[x y ...]	Square brackets enclose a set of optional syntax choices separated by vertical bars, from which you select one or none.
{ x y ... } *	Asterisk-marked braces enclose a set of required syntax choices separated by vertical bars, from which you select at least one.
[x y ...] *	Asterisk-marked square brackets enclose optional syntax choices separated by vertical bars, from which you select one choice, multiple choices, or none.
&<1-n>	The argument or keyword and argument combination before the ampersand (&) sign can be entered 1 to n times.
#	A line that starts with a pound (#) sign is comments.

GUI conventions

Convention	Description
Boldface	Window names, button names, field names, and menu items are in bold text. For example, the New User window appears; click OK .
>	Multi-level menus are separated by angle brackets. For example, File > Create > Folder .

Symbols

Convention	Description
 WARNING	An alert that calls attention to important information that if not understood or followed can result in personal injury.
 CAUTION	An alert that calls attention to important information that if not understood or followed can result in data loss, data corruption, or damage to hardware or software.
 IMPORTANT	An alert that calls attention to essential information.
NOTE	An alert that contains additional or supplementary information.
 TIP	An alert that provides helpful information.

Network topology icons



Represents a generic network device, such as a router, switch, or firewall.



Represents a routing-capable device, such as a router or Layer 3 switch.



Represents a generic switch, such as a Layer 2 or Layer 3 switch, or a router that supports Layer 2 forwarding and other Layer 2 features.

Port numbering in examples

The port numbers in this document are for illustration only and might be unavailable on your device.

Index

[A](#) [C](#) [E](#) [F](#) [G](#) [I](#) [L](#) [M](#) [P](#) [R](#) [S](#) [V](#)

A

Accessing the IRF fabric to verify the configuration, [60](#)

C

Configuration terminal problems, [63](#)

Configuring basic IRF settings, [59](#)

Connecting the console cable, [44](#)

Connecting the physical IRF ports, [60](#)

Connecting the power cord, [38](#)

Contacting HP, [84](#)

Conventions, [85](#)

Cooling system, [67](#)

E

Environmental specifications, [65](#)

Examining the installation site, [13](#)

F

Fan failure (only for the 5120 EI switches), [63](#)

G

Grounding the switch, [34](#)

I

Installation tools, [15](#)

Installing a 5120 EI switch in a 19-inch rack, [17](#)

Installing a 5120 SI switch in a 19-inch rack, [24](#)

Installing/removing an interface card (only for the 5120 EI switches), [41](#)

Interface cards (only for the 5120 EI switches), [69](#)

IRF fabric setup flowchart, [53](#)

L

LEDs (for the 5120 EI switches), [76](#)

LEDs (for the 5120 SI switches), [80](#)

M

Mounting the switch on a workbench, [30](#)

Mounting the switch through magnet mounting, [32](#)

Mounting the switch to a wall, [30](#)

P

Password loss, [61](#)

Physical specifications, [64](#)

Planning IRF fabric setup, [54](#)

Ports, [75](#)

Power specifications, [65](#)

Power supply failure, [61](#)

Powering on the switch, [48](#)

R

Related information, [84](#)

S

Safety recommendations, [13](#)

Setting terminal parameters, [45](#)

Setting up the configuration environment, [44](#)

SFP transceiver modules and SFP Stacking Kit (only for the 5120 SI switches), [73](#)

SFP/SFP+/XFP transceiver modules and SFP+/CX4 cables (only for the 5120 EI switches), [69](#)

V

Verifying the installation, [43](#)

Free Manuals Download Website

<http://myh66.com>

<http://usermanuals.us>

<http://www.somanuals.com>

<http://www.4manuals.cc>

<http://www.manual-lib.com>

<http://www.404manual.com>

<http://www.luxmanual.com>

<http://aubethermostatmanual.com>

Golf course search by state

<http://golfingnear.com>

Email search by domain

<http://emailbydomain.com>

Auto manuals search

<http://auto.somanuals.com>

TV manuals search

<http://tv.somanuals.com>