

Please read and save this Repair Parts Manual. Read this manual and the General Operating Instructions carefully before attempting to assemble, install, operate or maintain the product described. Protect yourself and others by observing all safety information. The Safety Instructions are contained in the General Operating Instructions. Failure to comply with the safety instructions accompanying this product could result in personal injury and/or property damage! Retain instructions for future reference. AMT reserves the right to discontinue any model or change specifications at any time without incurring any obligation.

©2006 American Machine & Tool Co., Inc. of PA, A Subsidiary of The Gorman-Rupp Company, All Rights Reserved.

▲ WARNING

Periodic maintenance and inspection is required on all pumps to insure proper operation. Unit must be clear of debris and sediment. Inspect for leaks and loose bolts. Failure to do so voids warranty.

3 Inch Self-Priming Centrifugal Pumps

Refer to form 1808-634-00 for General Operating and Safety Instructions.

Description

These centrifugal pumps are self-priming (to 20 ft. lift) units designed for high volume liquid transfer – irrigation, de-watering, lawn sprinkling, etc. They can also accommodate semi-solids (up to 1/2" dia.), sediment laden liquids, and liquids with entrained air or gases. Casing working pressure to 100 psi (689 kPa).

The units are equipped with a cast iron pump casing designed with a full dual volute, clog resistant semi-open stainless steel/bronze impeller, and a cast iron adapter. Units are equipped with flapper valves to assure a positive prime. A mechanical seal isolates the motor from the liquid in the pump casing. The units are coupled to 3600 RPM, totally enclosed fan cooled motors. All units are manual models, no controls are supplied. For use with nonflammable, non-abrasive liquids compatible with pump component materials.

Maintenance

Make certain that unit is disconnected from power source before attempting to service or remove any component.

▲ WARNING

NOTE: Pump casing should be removed and inspected periodically to insure that any foreign material or rust is not clogging internal pump parts. This unit is equipped with a dual volute pump casing. One of the volutes runs 180°, all the way from side opposite discharge into discharge through a completely enclosed passageway. If foreign material clogs this area, it can be dislodged by using a wire or long spring.

REMOVAL OF OLD SEAL

Refer to Figure 1

IMPORTANT: Always replace both seal seat (Ref. No. 10) and seal head (Ref. No. 11) to insure proper mating of components! Also, impeller seal washer (Ref. No. 14) should be replaced anytime impeller lock bolt (Ref. No. 15) has been removed.

1. Remove four bolts (Ref. No. 4) that connect adapter (Ref. No. 7) to casing (Ref. No. 16).
2. Remove casing and casing seal (Ref. No. 8).

▲ CAUTION

Care should be taken not to "pinch" or "shave" the o-ring gasket (Ref. No. 8) between adapter and casing.

3. Using an Allen wrench, remove impeller lock bolt, impeller seal washer, and impeller (Ref. No. 13).

IMPORTANT: Care should be taken to insure that same number of shim washers (Ref. No. 12) are replaced behind impeller as were removed. These shim washers are located directly behind impeller. These washers as well as impeller key (Ref. No. 2) become loose as impeller is removed.

4. Seal head and shaft sleeve can now be pulled from shaft.
5. Pry seal seat from adapter.
6. Push seal head from shaft sleeve.

INSTALLATION OF NEW SEAL

▲ CAUTION

The precision lapped faces on mechanical seal are easily damaged. Handle your replacement seal carefully.

1. Thoroughly clean all surfaces of seal seat cavity.
2. Using a clean cloth, wipe shaft and shaft sleeve and make certain that they are perfectly clean.
3. Wet the rubber portion of new seal seat with a light coating of soapy water. While wearing clean gloves or using a clean light rag, press seal seat squarely into adapter recess. Avoid scratching polished surface. If seal will not position properly, place a cardboard washer over polished surface and use a piece of pipe to press in, firmly but gently.

Specifications

Suction inlet	3" NPT
Discharge outlet	3" NPT
Motor (TEFC)	3 HP (Model 2874 & 2877)
	5 HP (Model 2875 & 2878)
	7.5 HP (Model 2876)
Power Supply:	
Model 2874, 2875, 2876:	230/460 VAC, 60 Hz, 3 Phase
Models 2877 and 2878:	230 VAC, 60 Hz, 1 Phase
RPM	3600
Pump construction	Cast Iron
Impeller material	Stainless Steel
STD Mechanical Seal	Carbon/ceramic
	Buna-N, S.S. springs and parts
Liquid temp	40° to 180° F (4° to 82° C)

NOTE: Data is subject to change without notice.

4. Dispose of cardboard washer. Check again to see that polished surface is free of dirt and all other foreign particles and that it has not been scratched or damaged.
5. Wet the inside of rubber portion of new seal head with a light coating of soapy water. Slide head onto shaft sleeve. Slide shaft sleeve with seal head onto motor shaft. Seal head and seal seat will meet. Reinstall any shims which have been removed. (See SHIM ADJUSTMENT section.)
6. Replace impeller key and impeller. Replace impeller seal washer before screwing impeller lock bolt in place.
7. Reassemble pump.
8. A short "run-in" period may be necessary to provide completely leak free seal operation.

SHIM ADJUSTMENT

When installing a replacement impeller (Ref. No. 13) or motor (Ref. No. 1), it may be necessary to adjust the number of shims (Ref. No. 12) to insure proper running clearance between impeller and casing (Ref. No. 16). Proceed as follows:

NOTE: A proper running clearance is less than 0.010".

1. For impeller replacement, add one (1)

- shim in addition to those removed originally.
- For motor replacement, add two (2) shims in addition to shims removed during disassembly.
 - Reassemble pump as described in steps 6 and 7. (See INSTALLATION OF NEW SEAL section.)

IMPORTANT: Insure that casing is snugly in place and check shaft to make sure it is turning freely (use screwdriver slot in the motor to turn shaft). If it turns freely, check to insure that adapter (Ref. No. 7) and casing are fitted metal -to- metal where

they meet on outside. If they are not metal-to-metal, tighten fasteners (Ref. No. 4) and recheck shaft for free turning. Tighten carefully, turning shaft while tightening so that motor bearings are not damaged in the event that too many shims were installed. If shaft seizes before fasteners are completely tight, disassembly pump and remove one (1) shim and repeat reassembly.

For Repair Parts, contact dealer where pump was purchased.

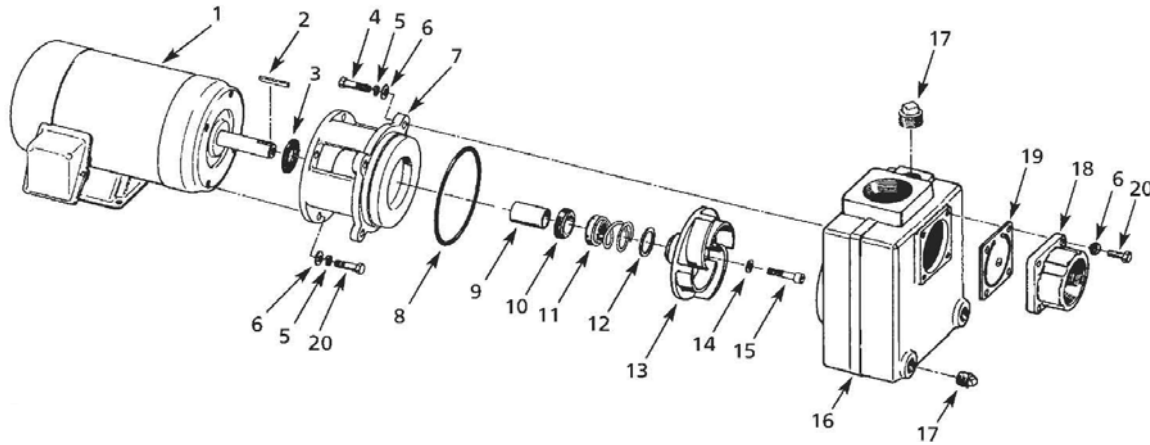

- Please provide following information:
 -Model number
 -Serial number (if any)
 -Part description and number as shown in parts list

Figure 1 – Repair Parts Illustration

Repair Parts List

Reference Number	Description	Part Number	Quantity
1	Motor: Model 2874-95 – 3 HP, 3 Phase Model 2875-95 – 5 HP, 3 Phase Model 2876-95 – 7.5 HP, 3 Phase Model 2877-95 – 3 HP, 1 Phase Model 2878-95 – 5 HP, 1 Phase	1626-043-00 1626-044-00 1626-045-00 1626-082-00 1626-078-00	1 1 1 1 1
2	Impeller Key	1471-030-00	1
3	Slinger Washer	1470-093-00	1
4	3/8"-16 UNC x 1-1/4" Grade 5 Hex Hd Cap Screw	*	4
5	3/8" Split Lock Washer	*	8
6	3/8" Flat Washer	*	12
7	Adapter	1470-001-02	1
8	O-Ring and Flapper Valve Kit, Buna (includes Ref. 14 & 15)	2870-301-91	1
8	O-Ring and Flapper Valve Kit, Viton (Includes Ref. 14 & 15)	2870-301-92	Optional
9	Shaft Sleeve S.S.	1472-000-00	1
10 & 11	†Seal Assembly Buna (standard)	1640-163-90	1
10 & 11	†Seal Assembly Viton (optional)	1640-163-91	1
12	Impeller Shim Set (one each 0.010", 0.020", 0.030")	1664-000-90	1
13	Impeller Kit, (Incl. 14 & 15) Model 2874-95 & 2877-95, 3 HP Model 2875-95 & 2878-95, 5 HP Model 2876-95, 7.5 HP	2874-013-90 2875-013-90 2876-013-90	1 1 1
14	Impeller Seal Washer	See Ref. 8 or 13	1
15	Impeller Screw, Stainless Steel	See Ref. 13	1
16	Casing	1543-003-01	1
17	3/4" NPT Pipe Plug	*	3
18	Suction Plate	1589-000-01	1
19	Flapper Valve Assembly	See Ref. 8	1
20	3/8"-16 UNC x 1-1/4" Hex Hd Cap Screw	*	8

(*) Standard hardware available locally.
 (†) Ref. No. 10 is seal seat. Ref No. 11 is seal head

Free Manuals Download Website

<http://myh66.com>

<http://usermanuals.us>

<http://www.somanuals.com>

<http://www.4manuals.cc>

<http://www.manual-lib.com>

<http://www.404manual.com>

<http://www.luxmanual.com>

<http://aubethermostatmanual.com>

Golf course search by state

<http://golfingnear.com>

Email search by domain

<http://emailbydomain.com>

Auto manuals search

<http://auto.somanuals.com>

TV manuals search

<http://tv.somanuals.com>